



BARROW ARCH 3D
PLAN OF OPERATIONS

PUBLIC COPY

TGS-NOPEC Geophysical Company

10451 Clay Road
Houston, TX 77041 USA
Tel: +1 713 860 2100
Fax: +1 713 334 3308
www.tgs.com

Troy Nelson
Senior Regulatory & Compliance Specialist
Tel: +1 403 781 1448

**THIS PAGE
INTENTIONALLY
LEFT BLANK**

Contents

1.	PROJECT OVERVIEW	5
2.	PROJECT LOCATION	6
3.	SURVEY OPERATIONS	7
3.1	Overview	7
3.1.1	Schedule of Activity	7
3.1.2	Mobilization/Demobilization	8
3.1.3	Land Based Activities	8
3.1.4	Source Vessel Operations	8
3.1.5	Receiver Deployment and Retrieval Operations	8
3.1.6	Housing/Logistics	9
3.2	3D Acquisition Parameters	9
3.3	Vessels	9
3.3.1	Node Recorder Deployment/Retrieval Vessels	11
3.3.2	Sound Source Vessels	11
3.3.3	Housing Vessels	12
3.3.4	Vessel Navigation	12
3.3.5	Vessel Tracking	12
3.4	Seismic Source	12
3.4.1	Overview	12
3.4.2	Towing Techniques	12
3.4.3	Source System Configuration	13
3.4.4	Sound Source Modeling and Field Verification	14
3.5	Ocean Bottom Node Recording System	15
3.6	Navigation and Positioning	16
3.6.1	Overview	16
3.6.2	Operational Redundancy Plan	16
3.6.3	Source Positioning	18
3.6.4	Receiver Positioning	18
3.6.5	Data Logging	19
3.6.6	Data Processing and Quality Control	Error! Bookmark not defined.
3.6.7	Hazard Assessments	19
3.6.8	Ancillary Systems	19
4.	MONITORING AND MITIGATION	20
4.1	Marine Mammals	20
4.1.1	Monitoring Program	20
4.2	Bird Encounters	22

4.3 Wildlife Interaction 22

5. OTHER ENVIRONMENTAL FACTORS 23

5.1 Subsistence Activities 23

5.2 Weather and Sea Ice 23

5.3 Obstructions and Navigation Hazards 23

5.4 Waste Management 23

5.5 Fueling Operations 24

6. COMMUNITY AND SUBSISTENCE USER OUTREACH..... 25

1. PROJECT OVERVIEW

TGS-NOPEC Geophysical Company (TGS) proposes to conduct approximately 2,340 square kilometers (km²), 905 square miles (mi²), of a 3D ocean-bottom node (OBN) seismic survey during the 2018, 2019 & 2020 open water periods in Alaska State and U.S Federal waters in Harrison Bay of the Beaufort Sea (Figure 1). The program will be conducted in phases, with approximately 650 km² to be acquired during 2018 within Phase 1. Operations will not be conducted in unbroken ice and pack ice will be avoided. The purpose of the proposed seismic program is to gather geophysical data using a 620-cubic inch (in³) seismic source array towed by seismic source vessel(s) and acquired by a nodal receiver array deployed on the ocean-bottom. Results of the 3D seismic program will be used to identify and map potential hydrocarbon-bearing formations and the geologic structures that surround them.

TGS plans to commence survey operations on approximately July 15th, 2018, with operations completing on or around October 31, 2018. Seismic operations are expected to occur over a period of approximately 100 days (depending on ice and weather conditions). The 2018 survey is proposed to be acquired along pre-determined track lines in the program area. As possible, operations will be conducted up to 24 hours per day, except as potentially needed for shut-down mitigation for marine mammals. The full 620 in³ sound source will only be operated during seismic acquisition on, near the end, and at the start of survey lines; during turns and transits between seismic lines, a single "mitigation" sound source (40 in³ or smaller) is proposed to be operated as a mitigation measure. The survey will also employ a marine mammal monitoring and mitigation program using vessel-based visual Protected Species Observers and other monitoring methodology if required.

TGS proposes to utilize up to 9 vessels for the survey including seismic source vessels, node deployment/retrieval vessels, a mitigation/housing vessel, and a crew transport vessel (see section 3.3 for vessel details). Seismic operations will be conducted in open waters to safely navigate the program area and deploy/retrieve the nodal equipment. Furthermore, as the proposed vessels do not have ice-breaking capabilities, TGS seismic operations are contingent on avoiding pack ice within the project area. To avoid pack ice conditions, TGS will employ the local knowledge, satellite imagery, and sea ice analysis expertise to plan the survey.

Operations will be conducted in compliance with all relevant regulatory permits and third-party agreements:

- Geological and Geophysical (G&G) permit from the Bureau of Ocean Energy Management (BOEM)
- Miscellaneous Land Use Permit (MLUP), Geophysical Exploration Application from the Alaska Division of Oil & Gas (ADOG)
- Incidental Harassment Authorization (IHA) from the National Marine Fisheries Service (NMFS)
- Letter of Authorization (LOA) from the U.S. Fish and Wildlife Service (USFWS)
- Marine Mammal Monitoring and Mitigation Plan (4MP)
- Conflict Avoidance Agreement (CAA) from the Alaska Eskimo Whaling Commission (AEWC)
- Letters of Notification to Oil & Gas Unit Operators

2. PROJECT LOCATION

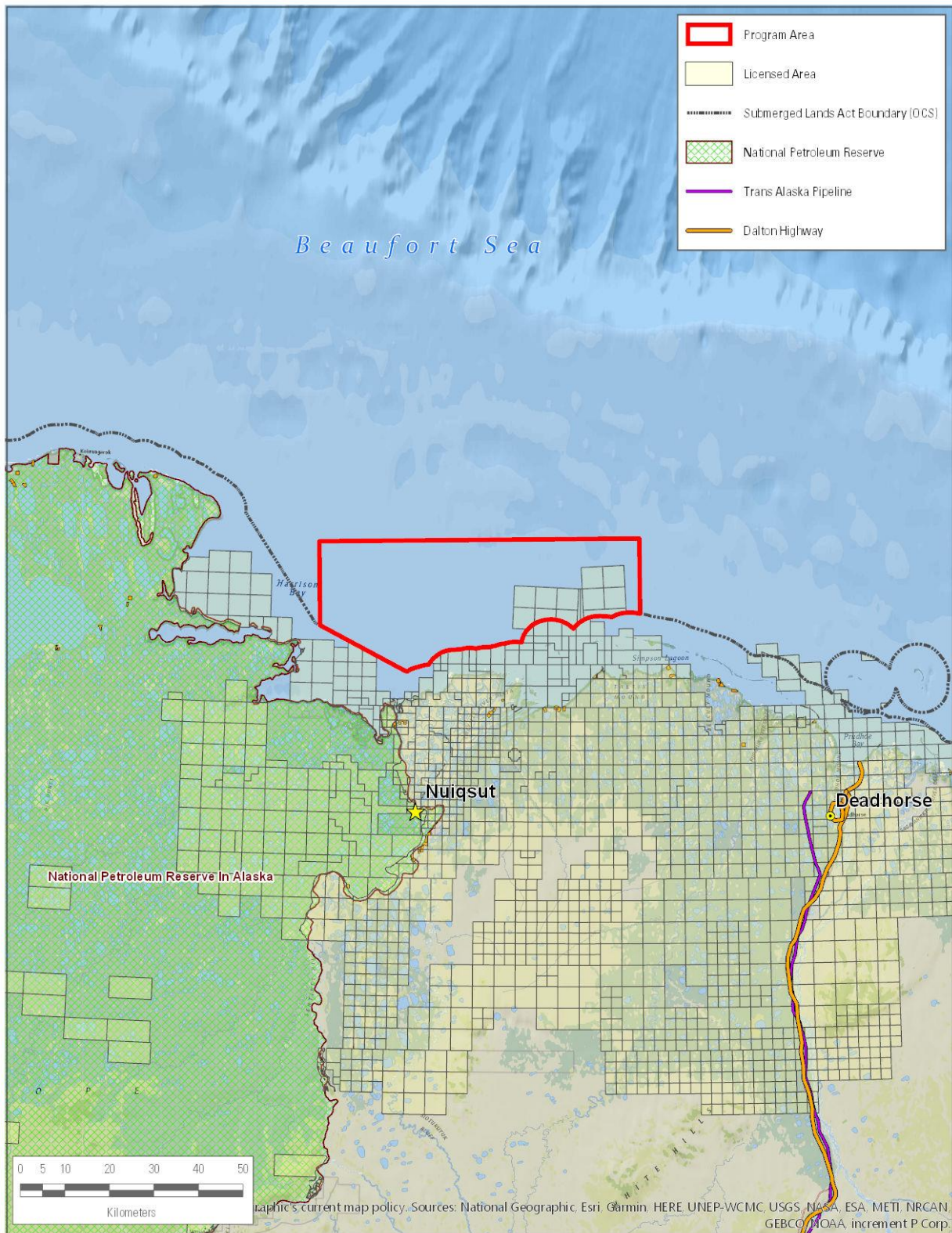

Figure 1: Area of operations for proposed Barrow Arch 3D survey

3. SURVEY OPERATIONS

3.1 Overview

TGS proposes to acquire the survey data for this program utilizing multiple vessels (Table 1, Section 3.3) with a seismic and maritime crew operated by Anchorage based SAExploration, Inc. (SAE) personnel. The survey vessels will also act as monitoring vessels, whose other purpose is to monitor the program area for marine mammals, secondary purposes included scouting for sea ice and navigational hazards. The operation will be conducted up to 24 hours per day as possible, except as potentially needed for shut-down mitigation for marine mammals.

A total of 2,340 km² of 3D acquisition is proposed for the multi-phase survey, with approximately 1,600 km² (620 mi²) located within Federal OCS waters and 740 km² (285 mi²) within Alaskan State waters. In 2018, approximately 650 km² is expected to be acquired within Phase 1 of the program area. Survey operations within the project area are expected to commence on July 15, 2018 and be completed by October 31, 2018.

Operations are structured on a recording patch approach (see Figure 7). Source vessels will travel along pre-determined 3D survey lines within the recording patch at a speed of about 4.5 knots or 8.3 kilometers per hour (kph). Source lines are orientated east/west and will only be acquired in water depths 2 m or deeper. Receivers line are orientated north/south and will be laid in deeper waters in the north of the survey to as close to the shoreline as possible in the south, up to 1m water depth. Once the source lines within the active patch are completed the nodes are picked up and laid again at another patch location, usually adjacent. The seismic source proposed will be a 620 in³ array towed at a depth of 2 m. Vessel positioning and source positioning will be provided by independent Differential Global Positioning Systems (DGPS).

The acquisition plan for this survey is to acquire survey lines starting either on the western or eastern edge of the program area. An example patch would start on the southern edge of the program area move north, acquiring patches in the receiver stroke until the northern edge is reached. The survey would reverse course and acquire patches in the adjacent stroke and move to the south (see Figure 8). The extent to which the northern survey lines can be acquired is dependent on the ice pack. In case of the presence of other industry operator activities (drilling, seismic surveys) or subsistence activity within the survey area, all operations will be coordinated with those activities as required.

3.1.1 Schedule of Activity

Seismic data acquisition is planned to commence as soon as the 2018 open water season is free of ice (July 15 to October 31) and will be completed by the end of October. Mobilization to the program area is planned to occur in mid to late-July. Vessels will be mobilized in Prudhoe Bay from Oliktok Dock and/or West Dock, where they will sail to the survey area. The larger vessels will transit from Anchorage (approximately 2 weeks) to the program area when sea ice conditions allow. All associated activities, including mobilization, surveying and demobilization of survey and support crews will occur inclusive of the above dates. The actual data acquisition is expected to take approximately 100 days. Based on past similar operations in the Beaufort Sea, it is expected that effective acquisition would occur over about 70 to 80 of the 100 days, due to weather, activity coordination, etc. If required in the AEW C's Conflict Avoidance Agreement (CAA), operations will temporarily cease during the fall bowhead whale hunt to avoid interference with the Nuiqsut and/or Utqiagvik based hunts. All timing of operations (start, crew change, and completion) is dependent on weather, sea ice, HSE concerns, logistics, and coordination with subsistence activities.

3.1.2 Mobilization/Demobilization

Smaller vessels will be transported overland to SAE operated staging areas in Prudhoe Bay. These locations will require letters of non-objection from land/lessee owners. Vessels could be launched from the West Dock facility and/or Oliktok when these areas are ice free, typically in early July. The larger vessels will transit by sea from Anchorage (approximately 2 weeks). After completion of the season the smaller vessels will be either dry docked at the staging areas in Prudhoe Bay (if there is a program in 2019) or transported overland, the larger vessels will transit back to Anchorage from the program area. Demob activities will ensure the larger vessels have transited through and are south of the Bering Strait by November 15.

3.1.3 Land Based Activities

All staging will occur on privately owned property and/or existing private facilities in the Prudhoe Bay area. Land based support activities, such as small vessel mobilization/demobilization and vessel re-supply are planned to occur at West Dock and or Oliktok Point. Transportation to staging areas and docks will be conducted with light duty trucks and buses on existing roads. If helicopters are used they will be based at existing facilities at Deadhorse, Kuparuk, or Alpine. Helicopters may be used to transport survey equipment and crew members. Vehicles will remain on existing roads.

3.1.4 Source Vessel Operations

One or two seismic source vessels will be used during the proposed survey. The primary seismic source for offshore recording consists of a single 620 in³ array. The array of the main source vessels will be towed at approximately 15 to 23 m from the stern at a depth of 2 m, which is remotely adjustable if needed. The source vessels will travel along pre-determined lines with a speed varying from approximately 1 to 5 knots (2 to 9 kph), mainly depending on the water depth. To limit the duration of the total survey, the source vessels will be operating simultaneously, with the operating source vessels alternating the sound source; this means that one vessel discharges the array when the other vessel is recharging. Source intervals are expected to be about 8 seconds for each array resulting in an overall interval of 4 seconds considering the alternating arrays. Operations are expected to occur 24 hours a day, with actual daily acquisition to total about 16-18 hours. Source lines are orientated east/west and will only be acquired in water depths 2 m or deeper. Source parameters are listed in section 3.2.

3.1.5 Receiver Deployment and Retrieval Operations

Jet driven shallow draft vessels and bow pickers will be used for the deployment and retrieval of nodes at predetermined locations for receivers. Each node is a multicomponent system (4C) containing three velocity sensors and a hydrophone. Each receiver line will vary in length depending on size of patch, and are spaced approximately 183 m (600 feet [ft]). apart. Receivers line are orientated north/south and will be laid in deeper waters in the north of the survey area, to as close to the shoreline as possible in the south, up to 1m water depth. Each receiver line has submersible marine sensor nodes tethered equidistant (30.5m; 100 ft) from each other along the length of the line. Receiver parameters are listed in section 3.2.

During recording of one patch, nodes from the previously surveyed patch will be retrieved, recharged, and data downloaded prior to redeployment of the nodes to the next patch. As patches are recorded, receiver lines are moved side to side or end to end to the next patch location so that receiver lines have continuous coverage of the recording area.

Autonomous recording nodes lack cables, but will be tethered together using a thin, non-kinking rope for ease of retrieval. This rope will lay on the seafloor, as will the nodes, and will have no effect on marine traffic. Primary vessel positioning will be achieved using GPS with the antenna attached to the seismic source array. Pingers deployed from the node vessels will be used for positioning nodes. The geometry/patch could be modified as operations progress to improve surveying and operational efficiency.

If needed in the surf zone, water jet driven shallow draft vessels and bow pickers will be used for the deployment and retrieval of the offshore recording equipment. These vessels can be rigged with hydraulically driven deployment and retrieval squirter crab blocks, allowing for automated deployment and retrieval from the bow or stern of the vessel. These nodes will not affect any marine traffic.

Nodes may be placed on the barrier islands to get full seismic coverage through these areas. The shallow draft bow picker vessels would land on the shoreline, where nodes would be placed by hand across the island(s). For this type of operation, the applicable LOA permit authorization for intentional harassment of polar bears will be obtained. In addition, archeological clearances will be secured from the relevant agencies for operations on the islands.

3.1.6 Housing/Logistics

Seismic data acquisition will occur over a 24-hour per day schedule. Approximately 100 personnel will be employed in the marine portion of the operation and possibly 35 land-based personnel at staging areas. Staffing will include seismic crew, vessel management, marine mammal observers, support personnel, pilots, mechanics, and overall project management.

Marine based personnel will be housed on the vessels provided in Table 1 with berths and food service. All land based staff will be housed in existing facilities at Deadhorse, or similar.

For protection from weather, vessels may anchor near the islands or other near shore area locations. Personnel transfers may also occur at land locations during survey activities. Surveyors will deploy navigation positioning base stations on land and may mark receiver locations in advance of the lay-out crews.

3.2 3D Acquisition Parameters

Recording Instrument	GeoSpace Four Component (4C) Ocean Bottom Recorder
Seismic Source Volume	620 in ³
Source Depth	6 feet (2 m)
Source Operating Pressure	2000 psi
Source Interval	50 ft (15.24 m)
Source Line Interval	600 ft (182.88 m)
Source Line Length (in patch)	3.64 mi (5.85 km)
Source Line Orientation	269.50°
Receiver Node Interval	100 ft (30.48 m)
Receiver Line Interval	600 ft (182.88 m)
Receiver Line Length (in active patch)	3.84 mi (6.18 km)
Receiver Line Orientation	179.50°
Recording Channels (in active patch)	1,632
Record Length	6 seconds
Sample Interval	2 milliseconds

3.3 Vessels

TGS plans to utilize up to 9 vessels for the survey including: seismic source vessels (2), node deployment/retrieval vessels (3 to 5), a mitigation/housing vessel, and a crew transport vessel. Table 1 lists

the proposed vessels (or similar) for the survey. In the event a specific vessel is not available for the survey, a vessel with similar parameters will be used. During operations average vessel speed will be 4-5 knots (8-9 kph). All vessels meet or exceed EPA tier two requirements.



Figure 2: Source Vessels and Seismic Source Array



Figure 3: Node Deployment/Retrieval Vessels

Table 1 – Vessel Summary

Vessel (or similar)	Operation	Size (ft)	Tonnage	Berths	Main Activity	Details
M/V Arctic Wolf	Source	150 x 38	472	22	Seismic data acquisition, 24-hour operation	Registry # Call sign: WDI2939 Owner: Aldrich Offshore Services
M/V Peregrine Falcon	Source	99 x 24	100	18	Seismic data acquisition, 24-hour operation	Registry # 950245 Call sign: WAV6285 Owner: Peregrine Falcon Alaska LLC.
M/V Miss Diane	Node equipment deployment/retrieval	85 x 20	80	6	Deploying/retrieving nodes, 24-hour operation	Registry # 120779 Call sign: WAV779 Owner: Peregrine Falcon Alaska LLC.
M/V Mark Steven	Node equipment deployment/retrieval	85 x 24	80	16	Deploying/retrieving nodes, 24-hour operation	Registry # 1238385 Call sign: WAV8385 Owner: Peregrine Falcon Alaska LLC.
M/V Maxime	Node equipment deployment/retrieval	70 x 16	48	10	Deploying/retrieving nodes, 24-hour operation	Registry # 1196716 Call sign: WDH6022 Owner: William T. Vogel
M/V Westward Wind	Mitigation/Housing	135 x 38	662	32	Crew housing, 24-hour operation	Registry # 7743467 Call sign: WCX9055 Owner: Aldrich Offshore Services
M/V Dreadnought	Crew Transport	30 x 20	20-30	3	Crew transport, intermittent every 8 hours	Registry # 1284089 Call sign: WAG4089 Owners: Rob and Debra Eckley
M/V Sleeprobber	Equipment Transport	32 x 14	48	1	Deploying/retrieving nodes, intermittent operation	Registry # 1258686 Call sign: WDG7715 Owner: Jeff Jensen
M/V Ruple Minze	Equipment Transport	32 x 14	48	1	Deploying/retrieving nodes, intermittent operation	Registry # 1243276 Call sign: WDG5952 Owner: Aers Inc.

3.3.1 Node Recorder Deployment/Retrieval Vessels

Jet driven shallow draft vessels and bow pickers can be used for the deployment and retrieval of the offshore recording equipment. These vessels can be rigged with hydraulically driven deployment, retrieval squirter and crab blocks allowing for automated deployment from the stern and retrieval from the bow of the vessel. Some of these vessels will carry the nodes on hydraulically driven conveyors to allow the nodes to be picked from the bow and moved to the rear for deployment, while the smaller vessels carry the recording equipment on the deck in fish totes.

3.3.2 Sound Source Vessels

Multi-purpose shallow draft landing crafts will be used for source vessels. Source vessels have the ability to deploy the array off the stern using large A-frames and winches and can operate in ultra-shallow waters due to 2-6 ft draft. On the source vessels, the source arrays (mounted in a cage) are typically carried on the stern deck with an umbilical that allow the arrays to be deployed and towed approximately 15 to 23 m off the stern. The larger forward deck allows for sufficient space for source compressors and additional source equipment to be stored.

3.3.3 Housing Vessels

Housing vessel(s) will be sufficient berthing to house crew and management personnel. The housing vessel will have ample office and bridge space to facilitate its role as the mother ship and central operations.

3.3.4 Vessel Navigation

Vessels are positioned via redundant DGPS units receiving PPP (precise point positioning) differential corrections. Primary and secondary systems are typically C-Nav units receiving Net-1 and Net-2 corrections respectively. Vessel heading measurements are made using GPS-based Trimble heading sensors, which may also be used as a tertiary DGPS system. Vessel attitude is measured using industry standard pitch and roll sensors. The static, radial standard deviation for PPP DGPS systems is approximately 10 cm horizontally and 20 cm vertically.

3.3.5 Vessel Tracking

Tracking and management of multiple vessels is handled through the NaviPac Helmsman's display. Vessels communicate via WiFi, UHF, or VSAT link to share position and status information. All vessels in the fleet may be monitored from any location equipped with a navigation display.

Additional vessel tracking capabilities include Iridium satellite based tracking systems. These systems consist of a small GPS enabled, satellite transponder on each asset to be tracked. The asset position information is reported on a password protected webpage that may be viewed by multiple users from any location with internet access.

3.4 Seismic Source

3.4.1 Overview

The array proposed has 8 active source chambers placed in two fixed 4 chamber strings, with maximum total volume of 620 in³, towed at a depth of 2 m. The source is made up of a single array and operated at 2000 psi air pressure. See Figure 4 for source array configuration.

Four near-field hydrophones are mounted approximately 1 m above the source chamber stations on one of the fixed strings in the array along with a high-pressure transducer to monitor the high-pressure supply. There is one RGPS pod located on the array, which transmits the positioning data back to the Source Tracking system onboard the vessel. All the data from these sensors is transmitted to the vessel for real time monitoring onboard via the Source Tracking system while being recorded in the header of the FFID which is then written to tape.

The source array modelling and geometry been calculated (sections 3.4.3.1 to 3.4.3.3) using GunDalf array modelling software and has been determined to be optimum to minimize the areal dimensions of the array to approximate point source radiation characteristics for frequencies in the nominal seismic processing band.

3.4.2 Towing Techniques

The air source chambers on the array are suspended from a prefabricated catamaran style frame. The arrays are typically carried on the stern deck with an umbilical that allows the array to be deployed and towed approximately 15 to 23 m off the stern of the source vessel.

3.4.3 Source System Configuration

The source for the survey is 620 in³ comprising of Teledyne BOLT 1990LLX manufactured seismic sources. The Teledyne BOLT 1990LLX seismic source designed for volumes ranging from. During acquisition of the survey area 8 individual active sources will be utilized with gun in³ volumes ranging from 40 in³ to 110 in³.

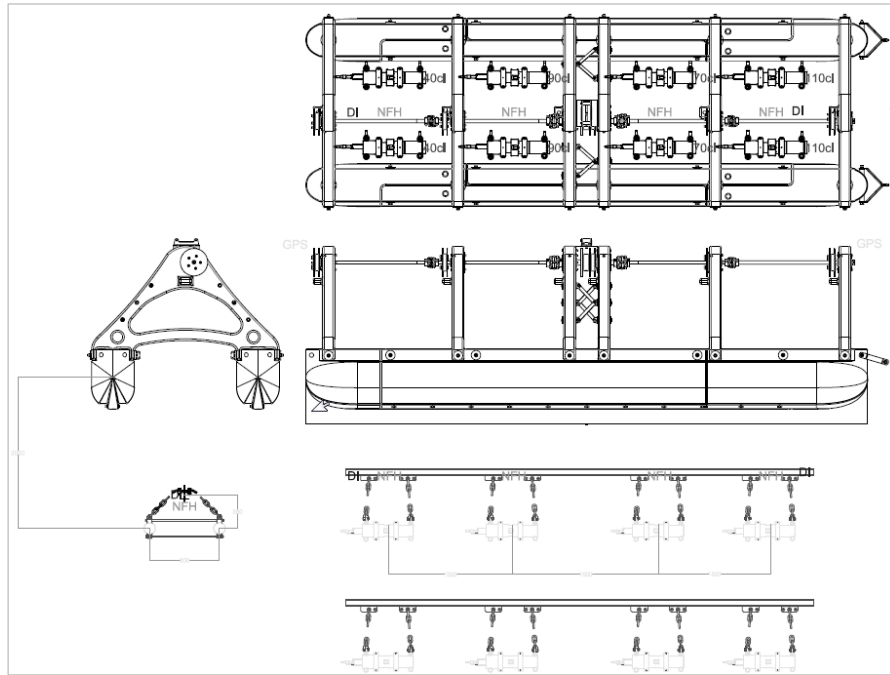
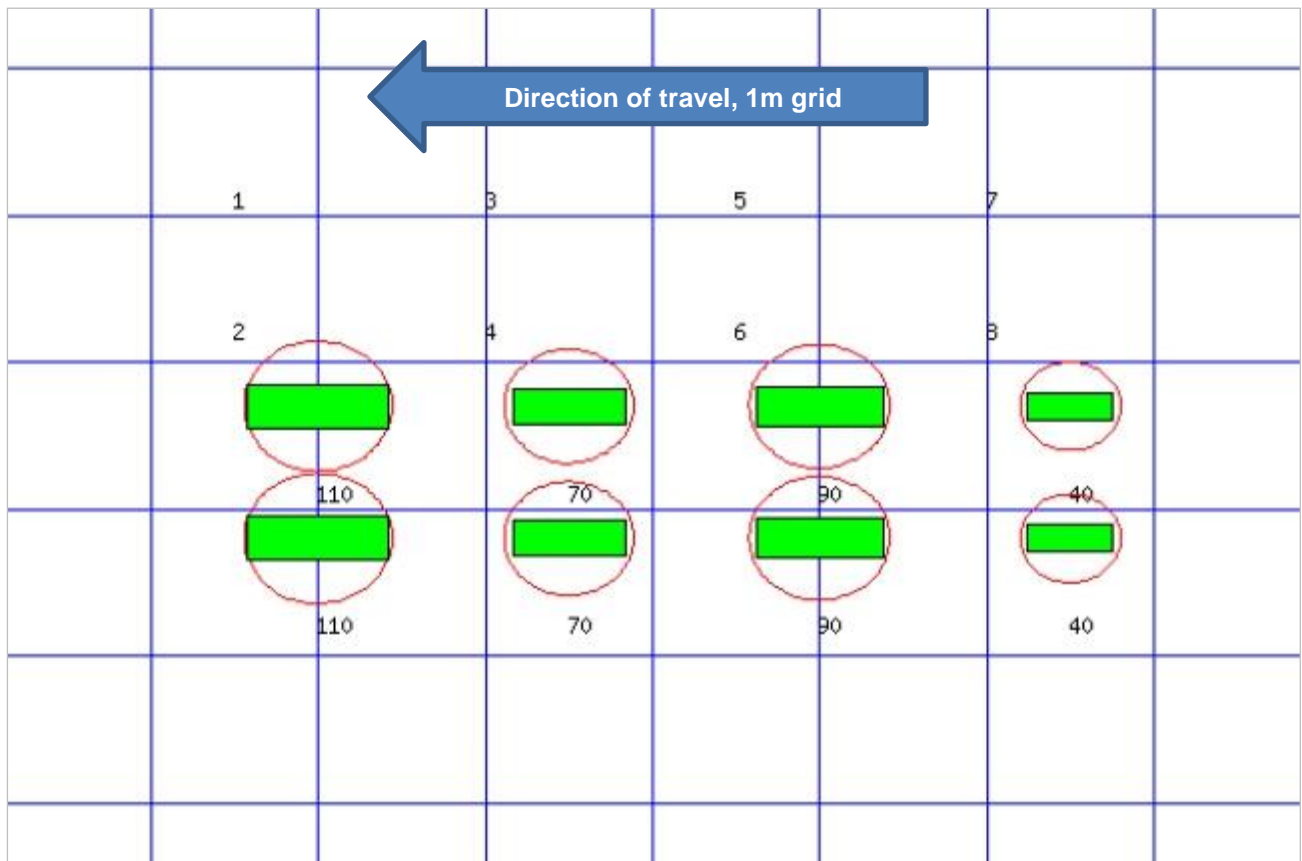

Figure 4: 620 in³ Source Array Configuration

3.4.3.1 Array Geometry and Source Contribution

Source	Pressure (psi)	Volume (in3)	Type	x (m)	y (m)	z (m)
1	2000	110.0	1900LLX	0.00	-0.45	3.00
2	2000	110.0	1900LLX	0.00	0.45	3.00
3	2000	70.0	1900LLX	1.50	-0.45	3.00
4	2000	70.0	1900LLX	1.50	0.45	3.00
5	2000	90.0	1900LLX	3.00	-0.45	3.00
6	2000	90.0	1900LLX	3.00	0.45	3.00
7	2000	40.0	1900LLX	4.50	-0.45	3.00
8	2000	40.0	1900LLX	4.50	0.45	3.00



3.4.4 Sound Source Modeling and Field Verification

SAE conducted a sound source verification (SSV) field test in 2014 in the Beaufort Sea for the same 620 in³ sound source array TGS is proposing. Results and analysis from SAE’s report “Sound Source Verification Final Report Colville Delta Seismic Program.” by Seiche Measurements Ltd. will be applied to the proposed 2018 survey.

The previous SSV conducted on the proposed 620 in³ recorded a 95th percentile radius of 1.93 km (1.20 mi), which is the radius that is be used in estimating Level B incidental take on marine mammals.

Because seismic surveys in the Beaufort Sea are not hindered by tides, seismic acquisition can occur around the clock. TGS is expected to acquire approximately 40.7 km² (15.72 mi²) per day, equivalent to a 6.95 x 5.86 km (4.32 x 3.64 mi) box or patch. To determine the daily Zone of Influence (ZOI) on marine mammals, a buffer of 1.93 km was placed around a 40.7 km² daily acquisition area box resulting in a ZOI of 105 km² (40.5 mi²).

Approximately 13.4% of the unit is within waters <2 m deep, areas in which nodes will be placed, but the seismic source will not operate (due to depth limitations of the towed arrays). Approximately 74.4% of the unit and 85.9% of the acquisition area (minus the 0-2 m depths) occurs in waters deep enough (>5 m) to provide habitat for cetaceans, although bowhead whales are typically found in waters >15 m deep, which comprises 39.6% of the 2018 survey area.

3.5 Ocean Bottom Node Recording System

Once the ocean bottom node (OBN) receivers for a stroke have been deployed they will autonomously and continually record data as the source vessel(s) transit along the pre-determined source lines. Data from these OBN units are retrieved only after the stroke has been successfully completed. After completion on that portion of the stroke patch, the nodes are retrieved and the seismic data is then downloaded and the nodes are redeployed north (or south) in the stroke. See the section below for a sample patch layout (Figure 5) and an example how a typical recording stroke is acquired (Figure 6).

The OBN system is designed for cable-free flexible subsea recording via high fidelity digitized 4C sensors. The OBN's sensor unit configuration contains field-proven three GS-ONE OMNI geophones and a MP-18BH-1000 hydrophone. The self-contained 24-bit recorder offers long term on-station deployment through the 16 GB memory and extended-life battery capacity. The high-speed data port and battery quick-chargers enable rapid re-deployment operations and cost effective seismic data acquisition.



Example of marine ocean bottom node

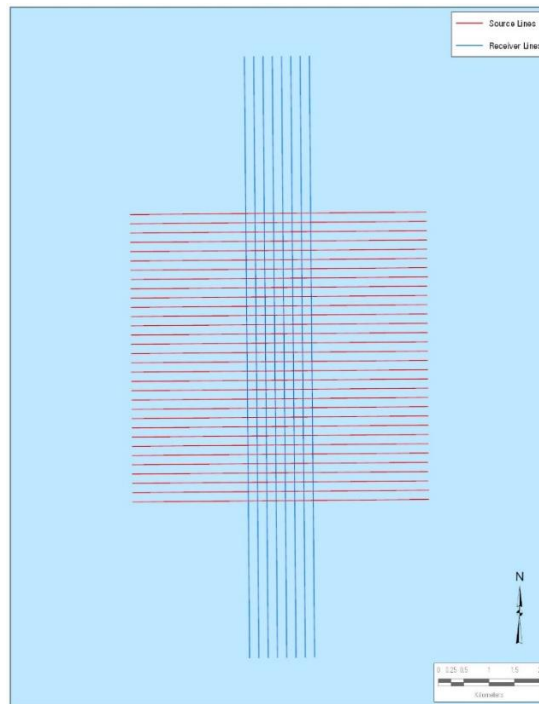

Figure 5: Sample Patch Layout

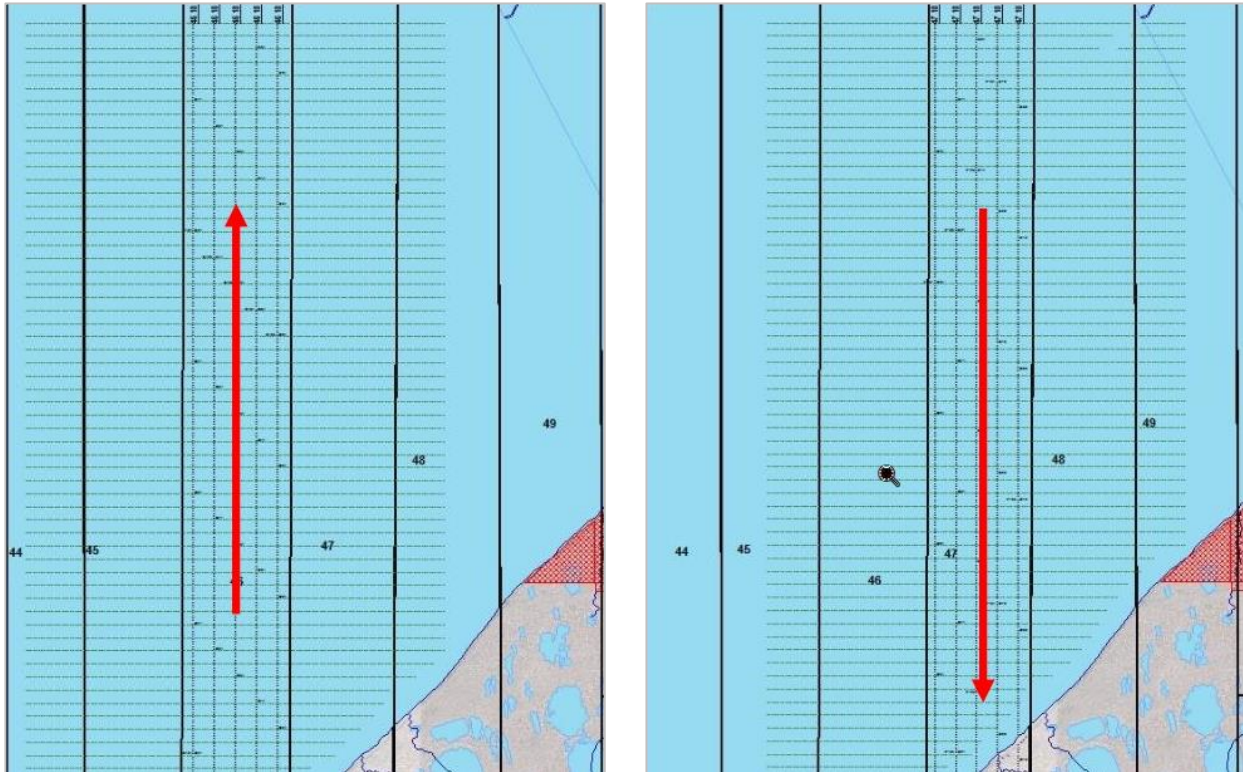

Figure 6: Sample OBN Stroke Acquisition
(arrows indicate direction of patch movement within survey stroke)

3.6 Navigation and Positioning

3.6.1 Overview

The navigation and positioning system has been further optimized for successful integration with nodal systems such as GeoSpace. Specifically, the proprietary Nodal Timing Unit is capable of microsecond timestamp accuracy, and the alignment of shots to coincide with node recording intervals. Also, NCS has developed multiple proprietary software modules for nodal surveys as add-ons to standard off-the-shelf packages. These modules include specific functionalities such as deployment (drop point) offset to account for water depth and ocean currents.

3.6.2 Operational Redundancy Plan

All survey vessels will be equipped with 100% operational redundancy for all survey positioning instruments. This will consist of primary and secondary systems for GPS position, heading, and attitude. Redundant GPS systems will consist of one CNav 3050 GPS receiver as primary. With a Hemisphere AtlasLink GNSS global corrections service. Alternatives to the AtlasLink is a Veripos LD5 DGPS receiver utilizing Veripos Ultra Corrections. Position fixes from both GPS systems will be interfaced to the integrated navigation system. Redundant vessel heading systems will consist of two Trimble SPS361 heading sensors. Heading information from both Trimble systems will be interfaced to the integrated navigation system. Redundant vessel attitude systems will consist of two Sonardyne Radian pitch and roll sensors. This information will be used to correct the position of the vessel for the effects of pitch and roll. Both attitude reference systems will be interfaced to the integrated navigation systems.

Table 2 specifies the survey sensors that will be operational on each of the survey vessels. The table also specifies the duty of each piece of equipment (surface position, heading, attitude, etc.) and the system redundancy (primary or secondary) where applicable.

Table 2 - Survey Sensors with redundancy.

System	Instrument
Surface Position (Primary)	CNAV 3050 DGPS Receiver utilizing C-Net 1 Differential Corrections
Surface Position(Secondary)	Hemisphere AtlasLink GNSS global correction service or Veripos LD5 DGPS Receiver utilizing Veripos ULTRA Differential Corrections
Heading (Primary)	Trimble SPS461 GPS Heading Sensor
Heading (Secondary)	Vessel Gyro, TSS Meridian Surveyor or equivalent
Attitude (Primary)	Sonardyne Radians Motion Sensor
Attitude (Secondary)	Sonardyne Radians Motion Sensor
Echosounder	Odom CV-100 Echosounder operating at 200 KHz
Sound Velocity in Water	Odom Digibar S Sound Velocity Profiler
UTC Time Synchronization (Primary)	NTP server on Primary Trimble SPS461 GPS
UTC Time Synchronization (Secondary)	NTP server on Secondary Trimble SPS461 GPS
USBL Positioning	Sonardyne Scout 8024 Transceiver

Seismic Receiver Deployment Control

This technology makes use of a sophisticated real-time seismic receiver installation control system which accurately computes the geometry and forces acting on the suspended Nodes On A Rope (NOAR), and the node touchdown position and bottom tension (or slack). This is accomplished by considering NOAR characteristics (size/weight), ship velocity, bathymetry, currents and all other parameters affecting the dynamic position and accuracy of the node lay (Figure 7). With such knowledge available at all times, immediate and accurate node lay forecasts and command decisions can be made that account for any complex real-world situation, both planned and unplanned.

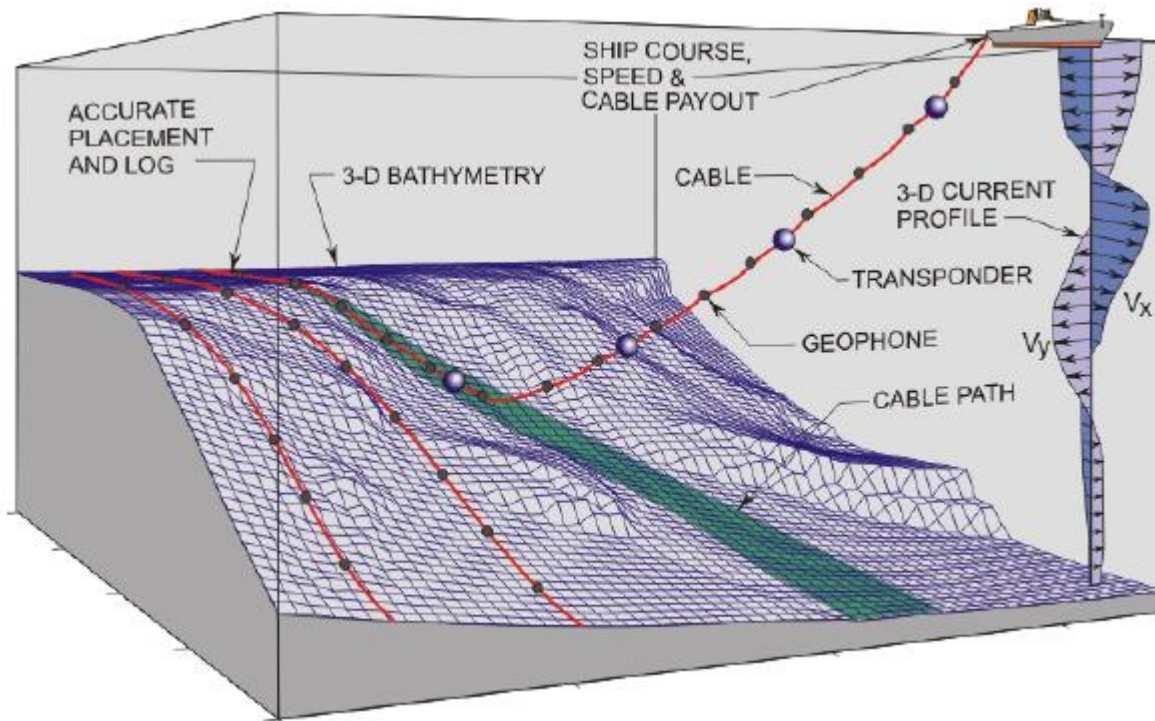

Figure 7: OBC Installation Example

This control system changes the focus of cable deployment control from the cable condition as it leaves the vessel (current practice for OBN) to its condition on the seafloor. The sophisticated computer model monitors in near real-time the node bottom conditions in the recent past and can predict the results of future cable and ship actions on node seafloor conditions. The result is a major improvement in the installer's knowledge of the NOAR condition on the seafloor and in his ability to predict and control touchdown conditions.

This software will be integrated with various systems such as the Sonardyne Scout, cable counters (if available), and vessel mounted ADCP.

3.6.3 Source Positioning

Source positioning is accomplished via SourcePoint DGPS system. The SourcePoint MK IV is fully waterproof, and has been ruggedized and internally shock-proofed to withstand the high forces associated with the constant, rapid acceleration experienced while mounted atop gun buoys or frames. The SourcePoint MK IV accepts differential corrections via RTCM from C-Nav, Veripos, WAAS or beacon sources. Only 2 wire pairs through the umbilical are required for operation. In general, the static, horizontal, radial standard deviation for SourcePoint MK IV units is approximately 1 m.

3.6.4 Receiver Positioning

USBL based receiver positioning is accomplished via the Sonardyne Scout Pro USBL system and Sonardyne 7815 TZ/OBC transponders. The Scout Pro USBL (Sonardyne 8024 transceiver) is a highly robust unit that was designed to work in conjunction with shallow water seismic crews. This is high-frequency USBL system that will communicate with the Sonardyne 7815 TZ/OBC transponder (the yellow transponder that is ubiquitous on shallow water bottom seismic crews). To our knowledge there are no other high-frequency USBL transceivers that will work with these transponders. The Scout Pro USBL system has been employed

on shallow water seismic crews since 2008 with very good results and has no reason to question the robustness of this system.

The overarching benefit of USBL is that XYZ solutions are available for each ping, and no 2-sided solution is required. This is based on the fact that USBL provides a range and bearing to a given transponder after each interrogation and reply, and does not require trilateration to establish geometry as with a range only system. USBL also offers the unique advantage of tracking the seismic equipment through the water column as it is deployed or retrieved. By utilizing the internal motion sensor in the Scout Pro transceiver, installation and calibration are greatly simplified. USBL accuracy, utilizing the internal motion sensor and an external heading sensor, is quoted at 0.5% slant range.

3.6.5 Data Logging

Survey data are logged in a variety of industry standard formats including P1, P2, and SPS. Proprietary formats are also logged, such as GeoSpace OBX.

3.6.6 Hazard Assessments

Pre-operations hazard assessment surveys are available to identify hazards to the seismic operation. These surveys may be conducted using single- and multi-beam sonars, sides-scan and radial/quadrant scanning sonars and marine magnetometers.

3.6.7 Ancillary Systems

The following ancillary systems can be provided:

- Tide gauges
- Current meters
- Velocimeters and CTDs
- Weather stations
- Long-range wireless Ethernet networks
- Support and temporary vessel tracking

4. MONITORING AND MITIGATION

4.1 Marine Mammals

The 3D seismic survey marine mammal monitoring and mitigation program will use a combination of vessel-based visual and other monitoring methodology as required. Vessel-based scientific and Inupiat Protected Species Observers (PSOs) will be on board the source and monitoring vessels to monitor the cetacean and pinniped Level A take safety zones and the Level B 160-dB incidental harassment zone. All monitoring will be implemented in accordance with the provisions of a NMFS-issued IHA and USFWS-issued LOA. The Level A safety zones mitigated for marine mammals are defined as the distances within which received sound levels exceed permanent threshold shifts (PTS) as defined under the 2016 NMFS guidance (<http://www.nmfs.noaa.gov/pr/acoustics/guidelines.htm>) for assessing the effects of anthropogenic noise. For large cetaceans, the calculated distance to the 183 SELcum threshold was 168 m, but PSOs will monitor a 1-km safety zone to partially avoid close-in Level B takes as well. The 185 SELcum phocid pinniped (ice seals) threshold was calculated at 28 m, which represents the safety zone radius for pinnipeds (the radius for beluga whales was 0 m). Below are the proposed safety zone radii to be implemented throughout survey operations.

Array (in ³)	Cetacean Safety Zone	Pinniped Safety Zone	Level B (Harassment) Zone (>160 dB)
620	1 km	28 m	1.93 km

The main purpose of the vessel based monitoring and mitigation program is to avoid and minimize exposure to marine mammals and ensure documentation of potential effects on marine mammals. This will ensure compliance with provisions of the IHA and the LOA. PSOs on both vessels have two primary responsibilities, mitigation and monitoring:

- Mitigation: Identify marine mammals within, or that could enter the applicable exclusion zone and initial immediate shut-down or power-down of the seismic source.
- Monitoring: Record data in reference to marine mammals both during seismic operations and inactive periods.

4.1.1 Monitoring Program

4.1.1.1 Vessel-based Visual Monitoring

Prior to the start of the seismic project, scientific and Inupiat PSOs will participate in a NMFS-approved Protected Species Observer (PSO) training course to familiarize themselves with local marine mammals, monitoring protocol, project-specific operational procedures, and data collections methods. PSOs will have current open-water/cold-water survival training (e.g., BOSIET) and be certified as fit-to-work offshore. During these trainings all participants will be notified of operational procedures relevant to health, safety, and environmental issues.

PSOs will be present for the duration of the project on both the survey acquisition vessels. A Lead PSO will be on each vessel and have additional responsibilities of data management, scheduling, and being the PSO point of contact for each vessel. PSOs will be on duty during all daylight vessel activities including transit.

PSO observations will be conducted from the bridge or best suitable vantage location. Data is to be recorded every time marine mammals are sighted. These data include date, time, location (latitude and longitude), species, total number in group, total number of juveniles, distance to vessel, whether the animals are in water

or hauled out on ice/land, behavior, behavioral reaction to vessel, behavioral pace, vessel operations at time of sighting, and mitigation measures (if required). All data will be entered into an observation software program which will have a built-in system for quality control. These data will later be exported for additional quality control and analysis. PSOs will also record environmental, observation effort, and vessel activities every 30-minutes or when conditions/activities change significantly.

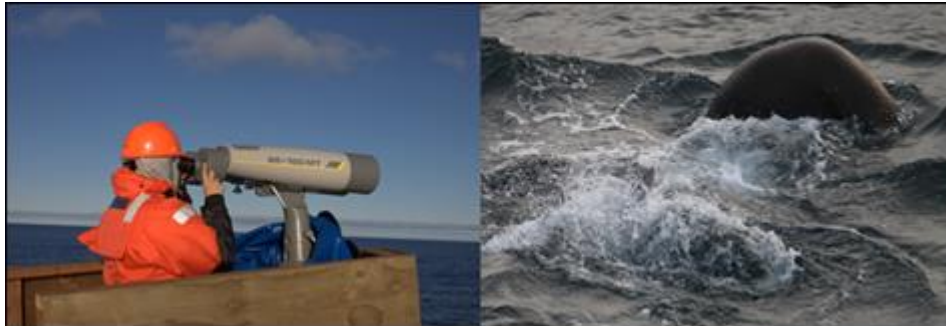

4.1.1.2 Mitigation Program

The mitigation measures to be implemented during the 3D seismic survey are summarized below and detailed in the project specific Marine Mammal Monitoring and Mitigation Plan (4MP). These will be implemented during all seismic operations, during mobilization, demobilization, and during all operations in support of the 3D seismic project.

Specific mitigation measures to be implemented, as applicable, include:

- Speed or course alterations to avoid marine mammals or subsistence activities
- PSOs to alert the crew and/or seismic source operators to the presence of marine mammals so that appropriate mitigation measures (i.e., shutdown, power down, and ramp up) can be initiated. TGS will implement mitigation (described below) relative to safety zones based on the NMFS Level A and Level B potential take thresholds for specific hearing groups. The applicable safety zone for cetaceans is 1 km and 28 m for pinnipeds.
 - *Shut-down Procedure*: a complete cessation of the seismic source. This is to be implemented if the marine mammal is observed within or about to enter the applicable safety zone. Seismic operations will not proceed until the marine mammal has cleared the applicable safety zone and the PSOs are confident that no marine mammals remain within the zone. The animal will be considered to have cleared the safety zone if it:
 - is visually observed to have left the applicable safety zone;
 - has not been seen within the safety zone for 15 minutes (pinnipeds) or 30 minutes (cetaceans).
 - *Power down*: de-energizing the seismic source when a marine mammal is observed outside, but approaching the safety zone, as an alternative to a shutdown. During a power down, a mitigation sound source (small volume such as 10 in³) will be operated. After a power down, sound source activity will not be allowed to resume until the marine mammal has cleared the applicable safety zone.
 - *Ramp-ups*: a gradual increase of the sound source volume involving a step-wise increase in the number and total volume of sources until the full volume is achieved. The purpose of the ramp up or “soft start” is to warn marine mammals potentially in the area and provide sufficient time for them to leave the survey area and avoid potential injury. Ramp up is used at the start of sound source operations, including after power down, after shut down, and after periods greater than 10 minutes without sound source operations. During ramp up, the applicable safety zone for the full array will be maintained.

- Following a complete shutdown (no mitigation sound source) of longer than 10 minutes, a 30-minute observational period will be conducted prior to ramp up to ensure no marine mammals are observed within the applicable safety zone. If the entire applicable safety zone has not been visible (i.e., thick fog or darkness) for at least 30 minutes prior to the start of operations, ramp up will not be permissible.
- Following a power down to the mitigation sound source, ramp up may commence without the 30-minute observational period and regardless of visibility conditions.

TGS will operate with due diligence and adhere to all stipulations and mitigation measures of their approved authorizations (NMFS IHA and USFWS LOAs) and the Conflict Avoidance Agreement (CAA).

4.2 Bird Encounters

Throughout survey operations all regulatory stipulations and Bird Reporting Guidance will be adhered to and followed. Bird encounter reporting forms are to be used and submitted to the required person(s), as per the regulatory permits.

The following bird handling procedures will be followed for each encounter:

- Bird will be left to rest and recover if it not in harm's way
- Ensure the bird can leave the vessel if desired
- Birds perching on ship structures (bow, lifeboat) will be allowed to rest and depart on their own.

4.3 Wildlife Interaction

TGS proposes to conduct node deployment operations (no source) on the barrier islands within the survey area. TGS has/will submit a Polar Bear Interaction Plan and an LOA application to USFWS for intentional harassment of polar bears. All relevant crew and personnel be given USFWS approved polar bear awareness training. TGS will consult with USFWS and local Iñupiat advisors to coordinate activities on and around the barrier islands.



5. OTHER ENVIRONMENTAL FACTORS

5.1 Subsistence Activities

The survey location in Harrison Bay ranges from nearshore to approximately 30 km offshore. As operations do not expect to commence until after July 25, potential impacts to spring marine mammal migrations and peak abundance periods, and subsistence hunts will be minimized. As TGS intends to commit to the AEWC's CAA in 2018, program activities in the fall will comply with the following stipulations for the Village of Nuiqsut:

- From Pt. Storkerson (~148 deg. 42 min. W) to Thetis Island (~150 deg. 10.2 min. W).
 - Inside the Barrier Islands: No geophysical activity prior to July 25. Geophysical activity is allowed from July 25 until completion of operations.
 - Outside the Barrier Islands: No geophysical activity from August 25 to close of fall bowhead whale hunting in Nuiqsut. Geophysical activity is allowed at all other times.

As outlined and detailed in the AEWC CAA, TGS expects to participate in the Communication and Call Center program for the Beaufort Sea in 2018. Vessel operators will routinely communicate with and monitor the Beaufort Sea call centers to be operated out of Nuiqsut and Utqiaġvik. This will enable the vessels to be aware of marine mammals and subsistence activity in the area.

All transiting to and from the project area will occur within the barrier islands. There is potential for non-seismic operations to occur close to the coastline from the Colville River headwaters east to Oliktok Point. This would include crew changes and equipment offloading. All activities will be coordinated closely with the AEWC, the Nuiqsut and Barrow (Utqiaġvik) Whaling Captain Associations, and the Village of Nuiqsut and Kuukpik Corporation to ensure seismic and transiting operations will not interfere with any ongoing subsistence hunting activities in the area.

5.2 Weather and Sea Ice

Weather forecasts and sea ice forecasts will be monitored throughout the duration of survey operations. Weather forecasts will be received via Buoy Weather and the Internet. To avoid pack ice conditions, TGS will employ the monitoring vessel, satellite imagery, and consultations with local traditional knowledge and ice expertise to plan the survey. The survey will progress with ice-free areas acquired first. Daily sea ice forecasts will be utilized from the NOAA National Ice Center website.

5.3 Obstructions and Navigation Hazards

There is expected to be no surface obstructions in the survey area. There may be weather buoys in the prospect which are expected to cause no interruption to survey operations. Other than local subsistence activity, vessel traffic is expected to be very infrequent and encounters with other boats a rare occurrence.

5.4 Waste Management

A waste management plan will be developed and implemented for each operating area, vessel operations, and staging sites. Wastes will be stored and hauled to Prudhoe Bay for treatment, or disposal in existing approved facilities. Staging areas will have waste accumulation areas where wastes generated by working crews will be transferred. Vessels will have USCG approved marine sanitation devices for handling

sewage. Vessel fluids will be managed in accordance with applicable governmental regulations. Solid wastes from vessels will be transferred to shore for handling at existing facilities.

5.5 Fueling Operations

Refueling of vessels at sea will be conducted with approved US Coast Guard procedures. Refueling of the vessels will take place at West Dock or by delivery from an approved vessel. All fuel will be stored at existing permitted facilities.

6. COMMUNITY AND SUBSISTENCE USER OUTREACH

In late March, TGS began notifying potential affected communities (Nuiqsut, Utqiaġvik, NSB) and user groups (AEWC, Village Whaling Captain Associations) of intended program activities. Depending on stakeholder schedule and availability, TGS intends to conduct Plan of Cooperation (POC) meetings in Utqiaġvik and Nuiqsut in early April, introducing and discussing the proposed program with community leadership and members and affected subsistence groups. TGS will continue to engage with the communities and stakeholder groups throughout the program permitting process, provide program updates to representatives of each, and conduct additional meetings in Utqiaġvik and Nuiqsut in late June or early July. The table below outlines the entities TGS intends to meet with in early April and going forward. A draft POC document will be prepared and provided to community leaders, NMFS, USFWS, and BOEM in advance of the meetings.

Type	Location	Entity Name
Local	Nuiqsut	<ul style="list-style-type: none"> ▪ City of Nuiqsut ▪ Native Village of Nuiqsut ▪ Kuukpik Corporation
	Utqiaġvik	<ul style="list-style-type: none"> ▪ City of Utqiaġvik ▪ Native Village of Utqiaġvik ▪ Ukpeaġvik Iñupiat Corporation
Regional	Utqiaġvik	<ul style="list-style-type: none"> ▪ NSB, Mayor's Office ▪ NSB Department of Wildlife Management ▪ Iñupiat Community of the Arctic Slope
Marine Mammal Co-management Groups	Varies	<ul style="list-style-type: none"> ▪ Alaska Eskimo Whaling Commission ▪ Village Whaling Captains Associations ▪ Alaska Ice Seal Committee ▪ Alaska Nanuuq Commission ▪ Alaska Eskimo Walrus Commission