

Liberty Development Project
Development and Production Plan
In the Beaufort Sea, Alaska

Draft Environmental Impact Statement

Volume 1. Executive Summary and Chapters 1 through 6

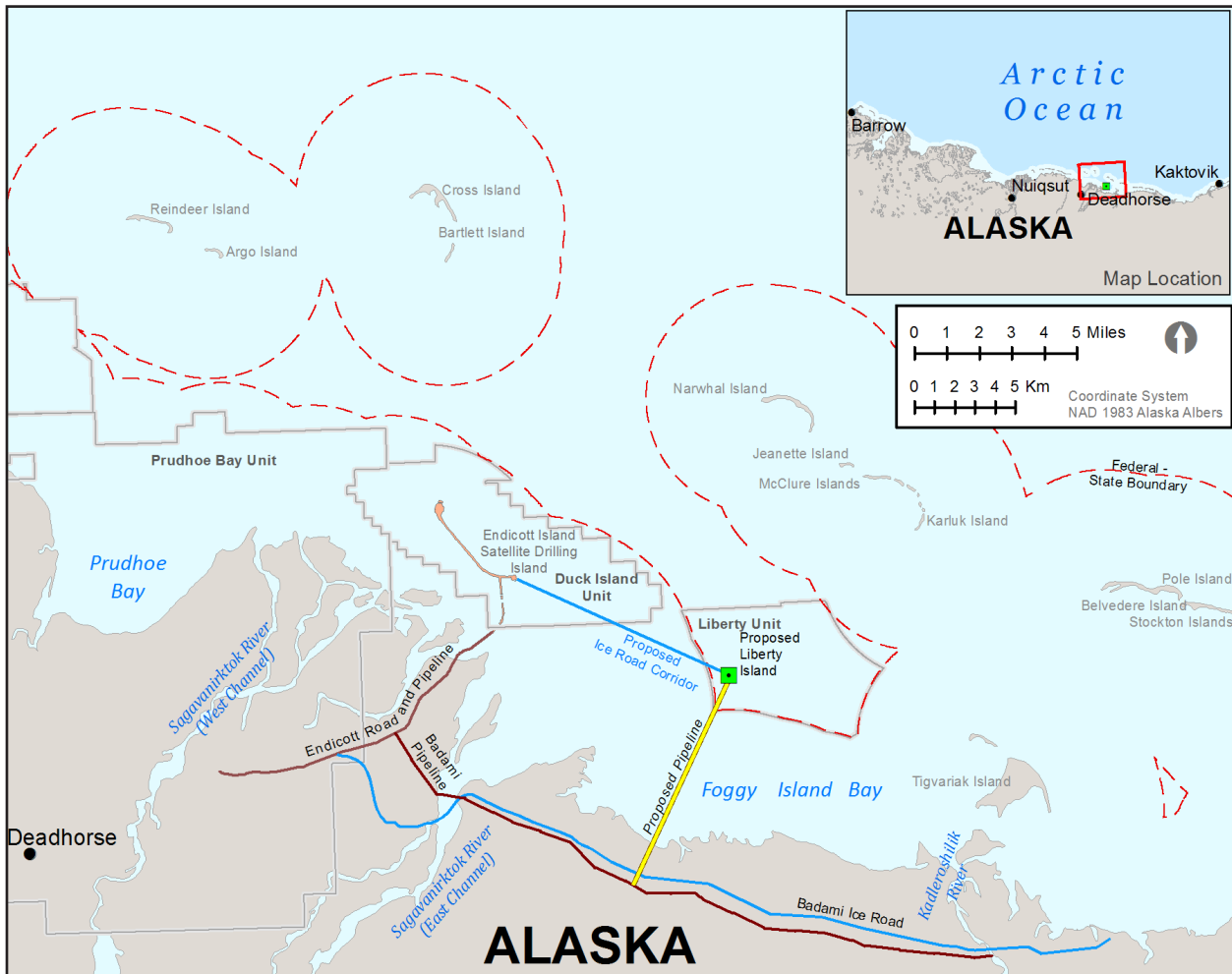

Liberty Development Project

Development and Production Plan
In the Beaufort Sea, Alaska

Draft Environmental Impact Statement

Volume 1. Executive Summary and Chapters 1 through 6

Prepared by

Bureau of Ocean Energy Management
Alaska OCS Region

Cooperating Agencies

U.S. Department of Commerce,
National Oceanographic and Atmospheric Administration,
National Marine Fisheries Service

Environmental Protection Agency

U.S. Department of Defense
U.S. Army Corps of Engineers

Inupiat Community of the Arctic Slope

North Slope Borough

**U.S. Department of the Interior
Bureau of Ocean Energy Management
Alaska OCS Region**

July 2017

Page Intentionally Left Blank

COVER SHEET

Beaufort Sea Liberty Development and Production Plan Environmental Impact Statement

Type of Action: **Draft (X)** **Final ()**
Administrative (X) Legislative ()

Area of Potential Effect: Offshore marine environment, Beaufort Sea coastal plain, and the North Slope Borough of Alaska.

Agency	Washington Contact	Region Contacts
U.S. Department of the Interior Bureau of Ocean Energy Management Alaska OCS Region 3801 Centerpoint Drive Suite 500 Anchorage, AK 99503-5823 (907) 334-5200	Geoffrey Wikel Bureau of Ocean Energy Management 45600 Woodland Road Sterling, VA 20166 (703) 787-1283	Frances Mann Chief, Environmental Analysis Section 2 (907) 334-5200 <hr style="border: 0; border-top: 1px solid black; margin: 5px 0;"/> Lauren Boldrick Project Manager (907) 334-5200

Abstract

Hilcorp Alaska LLC (HAK) proposes to produce oil from the Liberty Prospect (OCS Lease Y- 1650, OCS-Y-1586, and OCS-Y-1886) located in Foggy Island Bay in the Beaufort Sea, northeast of the Prudhoe Bay Unit and east of the Duck Island Unit. HAK submitted a Development and Production Plan (DPP) to BOEM on September 18, 2015, and a revised DPP on March 15, 2017.

BOEM received 46,678 comments during scoping. All comments, including those gathered in local Scoping Meetings, are available at www.regulations.gov.

HAK determined that the Liberty Prospect contains approximately 120 million barrels of recoverable crude oil. HAK proposes to construct a gravel island approximately 5 miles north of the Kadleroshilik River and 7.3 miles southeast of the existing Endicott Satellite Drilling Island (SDI) in approximately 19 feet of water. Sixteen wells would be drilled. Production facilities on Liberty Island would include producing wells designed to produce up to 65,000 barrels of crude oil and 120 million standard cubic feet of natural gas per day. The life of the proposed Liberty Prospect development is anticipated to be approximately 15-20 years.

Oil produced from the island would be piped through a pipe-in-pipe (PIP) subsea pipeline consisting of a 12-inch diameter inner pipe and a 16-inch diameter outer pipe. Subsea pipe would run 5.6 miles then transition to an elevated 1.5-mile long onshore pipeline to a tie in with the existing onshore Badami oil pipeline. This infrastructure would transport sales-quality oil (hydrocarbons) to the Trans-Alaska Pipeline System.

This Draft Environmental Impact Statement (EIS) assesses the Proposed Action and alternatives: Alternative 1 (Proposed Action or, the Liberty Development and Production Plan), Alternative 2 (the no action alternative) Alternative 3A (Relocate LDPI Approximately 1 Mile to the East). Alternative 3B (Relocate LDPI approximately 1.5 miles to the southwest), Alternative 4A (Relocate Oil and Gas Processing to Endicott SDI), Alternative 4A (Relocate Oil and Gas Processing to Endicott SDI), Alternative 4B (Relocate Oil and Gas Processing to a New Onshore Facility), Alternative 5A (East Kadleroshilik River Mine Site #2), Alternative 5B (East Kadleroshilik River Mine Site #3), and Alternative 5C (Duck Island Mine Site).

This page intentionally left blank

Acronyms and Abbreviations

This page intentionally left blank

Acronyms and Abbreviations

2D	Two-Dimensional
3D	Three-Dimensional
°C	Degrees Celsius
°F	Degrees Fahrenheit
µg/cm ³	Micrograms Per Cubic Centimeter
µg/g	Micrograms Per Gram
µg/m ³	Micrograms Per Cubic Meter
µg/L	Micrograms Per Liter
µPa	Micropascal
AAC	Alaska Administrative Code
ABL	Air Boundary Layer
ACCGIH	American Conference of Government Industrial Hygienists
ACIA	Arctic Climate Impact Assessment
ACMP	Alaska Coastal Management Program
ACP	Arctic Coastal Plain
ADCCED	Alaska Department of Commerce, Community, and Economic Development
ADEC	Alaska Department of Environmental Conservation
ADF&G	Alaska Department of Fish and Game
ADNR	Alaska Department of Natural Resources
ADOLWD	Alaska Department of Labor and Workforce Development
AEWC	Alaska Eskimo Whaling Commission
AFMP	Arctic Fishery Management Plan
AFN	Alaska Federation of Natives
AGL	Above Ground Level
AHRS	Alaska Heritage Resources Survey
AI/AN	American Indian and Alaskan Native populations
AK LNG	Alaska Liquefied Natural Gas Pipeline Project
AKNHP	Alaska Natural Heritage Program
AKPDES	Alaska Pollutant Discharge Elimination System
AMAP	Arctic Monitoring and Assessment Programme
AMNWR	Alaska Maritime National Wildlife Refuge
ANC	Alaska Nanuuq Commission
ANCSA	Alaska Native Claims Settlement Act
ANILCA	Alaska National Interest Land Conservation Act
ANIMIDA	Arctic Nearshore Impact Monitoring in the Development Area
ANS	Alaska North Slope
ANSO	Alaska North Slope Oil
ANWR	Arctic National Wildlife Refuge
AO	Arctic Oscillation
AOCSR	Alaska OCS Region
AOOS	Alaska Ocean Observing System
APD	Application for Permit to Drill
API	American Petroleum Institute
APPS	Act to Prevent Pollution from Ships
AQRP	Air Quality Regulatory Program
ARBO	Arctic Region Biological Opinion
ARRT	Alaska Regional Response Team
ASAMM	Aerial Surveys of Arctic Marine Mammals
ASL	Above Sea Level
ASRC	Arctic Slope Regional Corporation
ASWG	Alaska Shorebird Working Group
atm	Atmosphere (of Air Pressure)

AVALON/MERLIN.....	Integrated Avalon Nodal Analysis program and Merlin Oil and Gas Reservoir Simulator
AWC.....	Anadromous Waters Catalog of Alaska
AWI.....	Wainwright Airport
B.P.....	Before Present
BACT.....	Best Available Control Technology
Bbbl.....	Billion Barrels of Oil
bbls/d.....	barrels of oil per day
bbl.....	barrel=42 U.S. gallons
BC.....	Black Carbon
BCB.....	Bering-Chukchi-Beaufort Seas Stock of Bowhead Whales
Bcf.....	Billion Cubic Feet
Bcfg.....	Billion Cubic Feet of Gas
BE.....	Biological Evaluation
BH.....	Bowhead whale
BLM.....	Bureau of Land Management
BO.....	Biological Opinion
BOEMRE.....	Bureau of Ocean Energy Management, Regulation, and Enforcement
BOEM.....	Bureau of Ocean Energy Management
BOP.....	Blowout Preventer (System)
BOWFEST.....	Bowhead Whale Feeding Ecology Study
BP.....	British Petroleum
B.P.....	Before Present
BPXA.....	British Petroleum Exploration (Alaska)
BS.....	Boundary segment(s)
BSEE.....	Bureau of Safety and Environmental Enforcement
BWASP.....	Bowhead Whale Aerial Survey Project
CAA.....	Clean Air Act or Conflict Avoidance Agreement
CAA.....	Clean Air Act Amendments (1990)
CAB.....	Chemical and Benthos
CAH.....	Central Arctic (Caribou) Herd
CaCO ₃	Calcium Carbonate
CAVM.....	Circumpolar Arctic Vegetation Map
CAVMT.....	Circumpolar Arctic Vegetation Mapping Team
CBD.....	Center for Biological Diversity
CBMP.....	Circumpolar Biodiversity Monitoring Program (Arctic Council's)
CBS.....	Chukchi/Bering Seas Stock of Polar Bears
CD.....	Consistency Determination under CZMA
CDC.....	Centers for Disease Control
CEQ.....	Council on Environmental Quality
CER.....	Categorical Exclusion Review
CFCs.....	Chlorofluorocarbons
CFR.....	Code of Federal Regulations
CH ₄	Methane
CHAOZ.....	Chukchi Acoustic Oceanography and Zooplankton (program)
CI.....	Confidence Interval
CIAP.....	Coastal Impact Assistance Program
CIP.....	Capital Improvement Program
C/N.....	Carbon/Nitrogen Ratio
CO.....	Carbon Monoxide
CO ₂	Carbon Dioxide
CO ₃ ⁻²	Carbonate Ion
COMIDA.....	Chukchi Sea Offshore Monitoring in Drilling Area
Court of Appeals.....	United States Court of Appeals for the Ninth Circuit
cp.....	Centipoise (Measure of Viscosity)
CPAI.....	Conoco-Phillips Alaska Incorporated [2x in 5]

CWA	Clean Water Act
CZARA	Coastal Zone Act Reauthorization Amendments of 1990
CZM	Coastal Zone Management
CZMA	Coastal Zone Management Act
dB	Decibels
DBO	Distributed Biological Observatory
DEW	Distant Early Warning (system)
District Court	United States District Court for the District of Alaska
DO	Dissolved Oxygen
DPP	Development and Production Plan
DPS	Distinct Population Segment
Draft EIS	Draft Environmental Impact Statement
Draft SEIS	Draft Supplemental Environmental Impact Statement
DWH	Deepwater Horizon
EA	Environmental Assessment
EEZ	Exclusive Economic Zone
EFH	Essential Fish Habitat
EIS	Environmental Impact Statement
EJ	Environmental Justice
EO	Executive Order
EP	Exploration Plan
EPA	[U.S.] Environmental Protection Agency
EPS	Eastern Pacific Stock
ERA	Environmental Resource Area
ESA	Endangered Species Act
ESI	Environmental Sensitivity Index
ESP	Environmental Studies Program
EVOS	Exxon Valdez oil spill
EWC	Eskimo Walrus Commission
FEIS	Final Environmental Impact Statement
FHWG	Fisheries Hydroacoustic Working Group
FMP	Fishery Management Plan
FONSI	Finding of No Significant Impact
FOSC	Federal On-Scene Coordinator
FR	Federal Register
FSB	Federal Subsistence Board
FWPCA	Federal Water Pollution Control Act
FWS	U.S. Fish and Wildlife Service
GBS	Gravity-Based Structure
G&G	Geological and Geophysical
GHG	Greenhouse gases
g/m ³	Grams Per Cubic Meter
g/min	Grams Per Minute
GLS	Grouped Land Segments
GOM	Gulf of Mexico
GW	Gray Whale
ha	Hectares
HAP	Hazardous Air Pollutant
H ₂ S	Hydrogen Sulfide
HCs	Hydrocarbons
HDD	Horizontal Directional Drilling
HOR	Heavy Oil Residue
HSWUA	Hanna Shoal Walrus Use Area
Hz	Hertz
IAP	Integrated Activity Plan
IAPRC	Interagency Arctic Research Policy Committee

ICAS	Inupiat Community of the Arctic Slope
ID	Identification Number
IFR	Interim Final Rule
IHA	Incidental Harassment Authorization
IMO	International Maritime Organization
INC	Incident of Non-Compliance
IPCC	Intergovernmental Panel on Climate Change
IPF	Impact-Producing Factor
ISB	<i>In-Situ</i> Burn
ISC	Ice Seal Committee
ISER	Institute for Social and Economic Research
ITA	Incidental Take Authorization
ITL	Information to Lessees (Clauses)
ITR	Incidental Take Regulation
IUCN	International Union for Conservation of Nature
IWC	International Whaling Commission
JIT	Joint Investigation Team
kn	Knots
LA	Launch Area
LBCHU	Ledyard Bay Critical Habitat Unit
LDPI	Liberty Development and Production Island
Lease Sale 193	Chukchi Sea OCS Oil and Gas Lease Sale 193
LGM	Last Glacial Maximum
LIDAR	Light detection and ranging
LNG	Liquefied Natural Gas
LOA	Letter of Authorization
LOWC	Loss of Well Control
LPG	Liquid Petroleum Gas
LS	Land Segment
LTO	Landing And Takeoff Cycle
M	Million
MAIs	Maximum Allowable Increases
MARPOL	International Convention for the Prevention of Pollution from Ships
Mbbl	Thousand Barrels
MMbbl	Million Barrels
MBTA	Migratory Bird Treaty Act
MC	Mesoscale Cyclones
Mcf	Thousand Cubic Feet
Mcf/d	Thousand Cubic Feet per Day
Mcfg	Thousand Cubic Feet of Gas
md	Millidarcy (Measure of Permeability)
mg/g	Milligrams Per Gram
MMbbl	Million Barrels
MMC	Marine Mammal Commission
MMcf	Million Cubic Feet
MMcfg	Million Cubic Feet of Gas
MMPA	Marine Mammal Protection Act
MMS	Minerals Management Service
MMscfd	Million Standard Cubic Feet per Day
MOA	Memorandum of Agreement
MODU	Mobile Offshore Drilling Unit
MOU	Memorandum of Understanding
MOR	Moderate Oil Residue
MOVES	Motor Vehicle Emissions Simulator
mph	Miles Per Hour
m/s	Meters Per Second

m ³ /s.....	Cubic Meters Per Second
MWCS.....	Marine Well Containment System
NAAQS.....	National Ambient Air Quality Standards
NABC.....	Northwest Arctic Borough Code
NAE.....	National Academy of Engineering
NAO.....	North Atlantic Oscillation
NASA.....	National Aeronautic and Space Administration
NEPA.....	National Environmental Policy Act
NFS.....	National Forest System
NGL.....	Natural Gas Liquids
NGO.....	Non-Governmental Organization
NH ₄ ⁺	Ammonium Ion
NHPA.....	National Historic Preservation Act
NHRP.....	U.S. National Register of Historic Places
NISA.....	National Invasive Species Act of 1996
NMFS.....	National Marine Fisheries Service
nmi.....	Nautical Mile
NO.....	Nitric Oxide
N ₂ O.....	Nitrous Oxide
NO ₂	Nitrogen Dioxide
NO ₃	Nitrate Ion
NOAA.....	National Oceanographic and Atmospheric Administration
NOI.....	Notice of Intent
NO _x	Nitrogen Oxides
NPDES.....	National Pollutant Discharge Elimination System
NPFMC.....	North Pacific Fisheries Management Council
NPR-A.....	National Petroleum Reserve in Alaska
NPS.....	National Park Service
NRC.....	National Research Council or National Response Center
NRDA.....	Natural Resource Damage Assessment
NRHP.....	National Register of Historic Places
NSB.....	North Slope Borough
NSBMC.....	North Slope Borough Municipal Code
NSBSAC.....	North Slope Borough Science Advisory Committee
NSIDC.....	National Snow and Ice Data Center
NTAC's.....	Nondiscretionary Terms and Conditions
NTL.....	Notice to Lessees
NWAB.....	Northwest Arctic Borough
O ₃	Ozone
OCRM.....	Ocean and Coastal Resource Management
OCS.....	Outer Continental Shelf
OCSLA.....	Outer Continental Shelf Lands Act
OGP.....	(International Association of) Oil and Gas Producers
ONRR.....	Office of Natural Resource Revenue
OPA/OPA-90.....	Oil Pollution Act of 1990
OPD.....	Official Protraction Diagram
OSC.....	On-Scene Coordinator
OSFR.....	Oil Spill Financial Responsibility
OSRA.....	Oil Spill Risk Analysis
OSHA.....	Occupational Safety and Health Administration
OSR.....	Oil-Spill Response
OSRP.....	Oil Spill Response Plan
OWM.....	Oil Weathering Model
PAC.....	Pacific OCS Region
PACs.....	Poly Aromatic Compounds
PAH.....	Polycyclic Aromatic Hydrocarbons

PAME	Protection of the Arctic Marine Environment
Pb	Lead
PBR	Potential Biological Removal
PCB	Polychlorinated Biphenyl
PDO	Pacific Decadal Oscillation
PEA	Programmatic Environmental Assessment
PEIS	Programmatic Environmental Impact Statement
PEL	Permissible Exposure Limit
PL	Pipeline Segment
PM	Particulate Matter
PM _{2.5}	Fine particulate matter with an aerodynamic diameter of 2.5 micrometers or less
PM ₁₀	Coarse particulate matter with an aerodynamic diameter of 10 micrometers or less
PMC	Polar Mesoscale Cyclone
PO ₄	Phosphate Ion
ppb	Parts Per Billion
ppbv	Parts Per Billion By Volume
ppmv	Parts Per Million By Volume
PSD	Prevention of Significant Deterioration
psi	Pounds Per Square Inch
psig	Pounds per Square Inch Gauge Pressure
PSO	Protected Species Observer
psu	Practical Salinity Unit
PTS	Permanent Threshold Shift
RCRA	Resource Conservation and Recovery Act
RD	Regional Director
RHA	Rivers and Harbors Act
Rms	Root Mean Squared
ROD	Record of Decision
ROI	Record of Increase
ROMS	Regional Ocean Modeling System
ROW	Right-Of-Way
RP	Responsible Party or Recommended Practice
RPM's	Reasonably Prudent Measures
RS/FO	Regional Supervisor/Field Operations
RSV	Royalty Suspension Volume
RUSALCA	Russian-American Long-term Census of the Arctic
SAR	Search and Rescue
SAON	Sustaining Arctic Observing Network
SBS	Southern Beaufort Sea Stock Of Polar Bears
scf	Standard Cubic Foot
SCR	Selective Catalytic Reduction
SDH	Social Determinants of Health
Secretary	Secretary of the Interior
SEIS	Supplemental Environmental Impact Statement
SEL	Sound Exposure Level
SEMS	Safety and Environmental Management Systems
SHPO	State Historic Preservation Officer
SIP	State Implementation Plan
SL	Significance Level (in air quality standards)
SLA	Submerged Lands Act
SLIE	Seaward Landfast Ice Edge
SLS	Spring Lead System
SNAPs	Snap Shots of State Population Data
SO ₂	Sulfur Dioxide
SO ₄	Sulfate Ion
SO _x	Sulfur Oxides

SFF	Summer Fall Feeding
SSO	Sub-Surface Oil
SSOR	Sub-Surface Oil Residue
stb	Stock-Tank Or Standard Barrel
STP	Seawater Treatment Plant
SUA	Subsistence Use Area
Sv	Sverdrups
TAGA	Trace Atmospheric Gas Analyzer
TAPS	Trans-Alaska Pipeline System
Tcf	Trillion Cubic Feet
Tcfg	Trillion Cubic Feet Of Gas
TCH	Teshkepuk Lake Caribou Herd
TEK	Traditional Environmental Knowledge
TLV	Threshold Limit Value
TOC	Total Organic Carbon
TSLA	Teshakpuk Lake Special Management Area
TSP	Total Suspended Particles
TTS	Temporary Threshold Shift
UAF	University of Alaska, Fairbanks
UD	Utilization Distribution
UERR	Undiscovered Economically Recoverable Resources
ULSD	Ultra-Low Sulfur Diesel Fuel
UME	Unusual Mortality Event
UNFCCC	United Nations Framework Convention on Climate Change
USACE	U.S. Army Corps of Engineers
USC	United States Code
USCG	United States Coast Guard
USDOC	U.S. Department of Commerce
USDOI	U.S. Department of the Interior
USEPA	U.S. Environmental Protection Agency
USFWS	U.S. Fish and Wildlife Service
USFDA	U.S. Food and Drug Administration
USGS	U.S. Geological Survey
UTRR	Undiscovered Technically Recoverable Resources
UV	Ultraviolet
VGP	Vessel General Permit
VLOS	Very Large Oil Spill
VOC	Volatile Organic Compounds
VSM	Vertical Support Member (Supports above-ground oil and gas pipelines)
WAH	Western Arctic (Caribou) Herd
WCD	Worst Case Discharge
WHO	World Health Organization
WPS	Western Pacific Stock

Executive Summary

This page intentionally left blank

Executive Summary Table of Contents

Executive Summary.....	ES-1
Introduction and Background	ES-1
Purpose and Need for the Proposed Action.....	ES-1
Regulatory and Administrative Framework	ES-2
Scoping.....	ES-2
Proposed Action and Alternatives.....	ES-2
Alternative 2 (No Action)	ES-4
Alternative 3 (Alternate LDPI locations).....	ES-4
Alternative 4 (Relocate Oil and Gas Processing off of LDPI).....	ES-5
Alternative 5 (Alternate Gravel Sources)	ES-6
Alternatives Considered But Not Carried Forward for Further Analysis	ES-6
Affected Environment.....	ES-7
Environmental Consequences.....	ES-7
Very Large Oil Spill (VLOS) Scenario and Effects.....	ES-11
Cumulative Effects.....	ES-11
Consultation and Coordination	ES-11
Appendices	ES-12

List of Figures

Figure ES-1. Proposed Action.....	ES-3
Figure ES-2. Alternative 3.....	ES-5
Figure ES-3. Alternative Gravel Mine Locations.....	ES-6

List of Tables

Table ES-1. Potential Impacts of the Proposed Action by Resource.....	ES-9
Table ES-2. Comparison of Impacts to Resources by Alternative.....	ES-10

This page intentionally left blank

EXECUTIVE SUMMARY

INTRODUCTION AND BACKGROUND

The Bureau of Ocean Energy Management (BOEM) has prepared this Draft Environmental Impact Statement (DEIS) to analyze the impacts of the Liberty Development and Production Plan (DPP) submitted by Hilcorp, Alaska, LLC (HAK) on September 8, 2015 and amended on March 17, 2017.

The Liberty Reservoir was first discovered by Shell Oil Company. Shell drilled four wells between 1982 and 1987 to evaluate the potential of the Kekiktuk Formation in Foggy Island Bay. Three of the wells were drilled from Tern Island, which Shell constructed in 1981-1982. The fourth well was drilled from Goose Island, located southeast of Tern Island. In September 1996, BP Exploration Alaska (BPXA) acquired Lease OCS-Y-1650 in OCS Lease Sale 144, and initiated exploration permitting activity for the Liberty No. 1 Exploration Well. The surface location for this well was a gravel and ice structure situated on top of the abandoned Tern Island on Lease OCS-Y-1585 (Lease Sale 124), with the bottom-hole location (bottom of the drilled well) in Lease OCS-Y-1650. Tern Island is currently abandoned and eroding.

In 1998, BPXA submitted the first Liberty DPP to the Minerals Management Service (MMS—now BOEM). This DPP proposed a gravel island in the Beaufort Sea with a buried subsea pipeline to shore that would tie in to the Badami pipeline. MMS issued a final EIS (FEIS) concerning this DPP in May of 2002, but did not issue a Record of Decision, as BPXA put this project on hold in 2001 to re-evaluate the project and study the lessons learned at Northstar (an existing gravel island development in the Beaufort Sea).

In 2005, BPXA submitted another DPP to MMS that proposed drilling ultra-extended-reach (uERD) wells from an onshore location to the existing satellite drilling island (SDI) on the Endicott causeway. The proposed land-based project was intended to eliminate the gravel island and subsea pipeline components of the prior DPP, for the stated purpose of mitigating impacts related to the Boulder Patch, marine mammals, and concerns related to subsistence whaling. [The Boulder Patch is an ecologically important area within Stefansson Sound generally defined by having a greater than 10% cover of small boulders and cobblestone on the benthic surface (Martin and Gallaway, 1994), which supports the richest and most diverse biological communities known in the Beaufort Sea (Dunton, Reimnitz, and Schonberg, 1982). See Section 3.2.1 Lower Trophics for more information.]

BOEM prepared an Environmental Assessment of the impacts of this 2005 DPP and issued a Finding of No Significant Impact in November 2007. BPXA, however, determined there were safer and more technically sound development alternatives and cancelled the uERD project in 2012.

In April 2014, BPXA sold 50% ownership and full operatorship of the Liberty field to HAK.

HAK incorporated the concepts of the original 1998 BPXA Liberty DPP (which proposed a gravel island) into its December 30, 2014 DPP. This is the Proposed Action evaluated in this DEIS.

In 2016, the Bureau of Safety and Environmental Enforcement (BSEE) approved expansion of the unit to include Lease OCS-Y-1886 from Lease Sale 202; this 2.7 acre sliver results from a GPS mapping conversion.

PURPOSE AND NEED FOR THE PROPOSED ACTION

The purpose of the Proposed Action is to recover and process oil from the Liberty oil field and transport sales-quality oil to market. The need for this action is established by BOEM's responsibility under the Outer Continental Shelf Lands Act (OCSLA) to make OCS lands available for expeditious and orderly development, subject to environmental safeguards, in a manner which is consistent with the maintenance of competition and other national needs. The OCSLA also specifies the submittal

and review processes for proposed DPPs, and establishes the circumstances under which proposed DPPs are to be approved, modified, or disapproved.

REGULATORY AND ADMINISTRATIVE FRAMEWORK

A number of Federal agencies are using this EIS to meet their own regulatory (and in some cases, NEPA) requirements concerning activities described within the Liberty Development and Production Plan that fall under their respective jurisdiction. The Bureau of Safety and Environmental Enforcement (BSEE), the Environmental Protection Agency (EPA), and the U.S. Army Corps of Engineers (USACE) are all adopting this EIS to satisfy NEPA requirements associated with their proposed regulatory actions concerning various activities described in the DPP.

The National Marine Fisheries Service (NMFS), the U.S. Fish and Wildlife Service (USFWS), the Pipeline and Hazardous Materials Safety Administration (PHMSA), and the State of Alaska Department of Natural Resources (SOA DNR) will use the environmental analysis contained herein to inform their regulatory reviews of various activities described in the DPP.

SCOPING

Scoping is the ongoing public process to identify issues, alternatives, and mitigation measures to be considered for in-depth analysis in the EIS. As part of the scoping process, BOEM considered:

- Prior plans to develop the Liberty reservoir, along with alternative approaches identified in previous NEPA reviews;
- Public responses provided during scoping meetings held in Anchorage, Fairbanks, Barrow, Kaktovik, and Nuiqsut during November 2015;
- Public comments submitted to www.regulations.gov during the scoping period; and
- Input from Cooperating Agencies.

BOEM held a series of meetings with the Cooperating Agencies from fall 2015 through spring 2016 to develop, screen, and select alternatives for full analysis in the Draft EIS. BOEM held a workshop for alternatives development in February 2016 with all Cooperating Agencies, and provided draft alternatives for cooperating agency review in June 2016.

BOEM conducted a screening process to determine which of the suggested alternatives were technically and economically feasible, met the Purpose and Need, and were “reasonable” alternatives to consider under NEPA. Based on this screening process, BOEM retained three Action Alternatives (each comprised of multiple sub-Alternatives), in addition to the Proposed Action and No Action alternative required by NEPA. Alternatives which were screened out during this process are described in Section 2.3 Alternatives Considered but Not Carried Forward for Further Analysis.

PROPOSED ACTION AND ALTERNATIVES

The Proposed Action is a self-contained offshore drilling and production facility located on an artificial gravel island to be called the Liberty Development and Production Island (LDPI), with a pipeline to shore.

The proposed LDPI:

- Would be located approximately 5 miles north of the Kadleroshilik River and 7.3 miles southeast of the existing Endicott Satellite Drilling Island (SDI)
- Would be built in approximately 19 feet (ft) of water with the elevation of the top of the LDPI +15 ft above Mean Lower Low Water (MLLW) level
- Would have a work surface of approximately 9.3 acres (ac)

- Would have a seabed footprint of approximately 24 ac

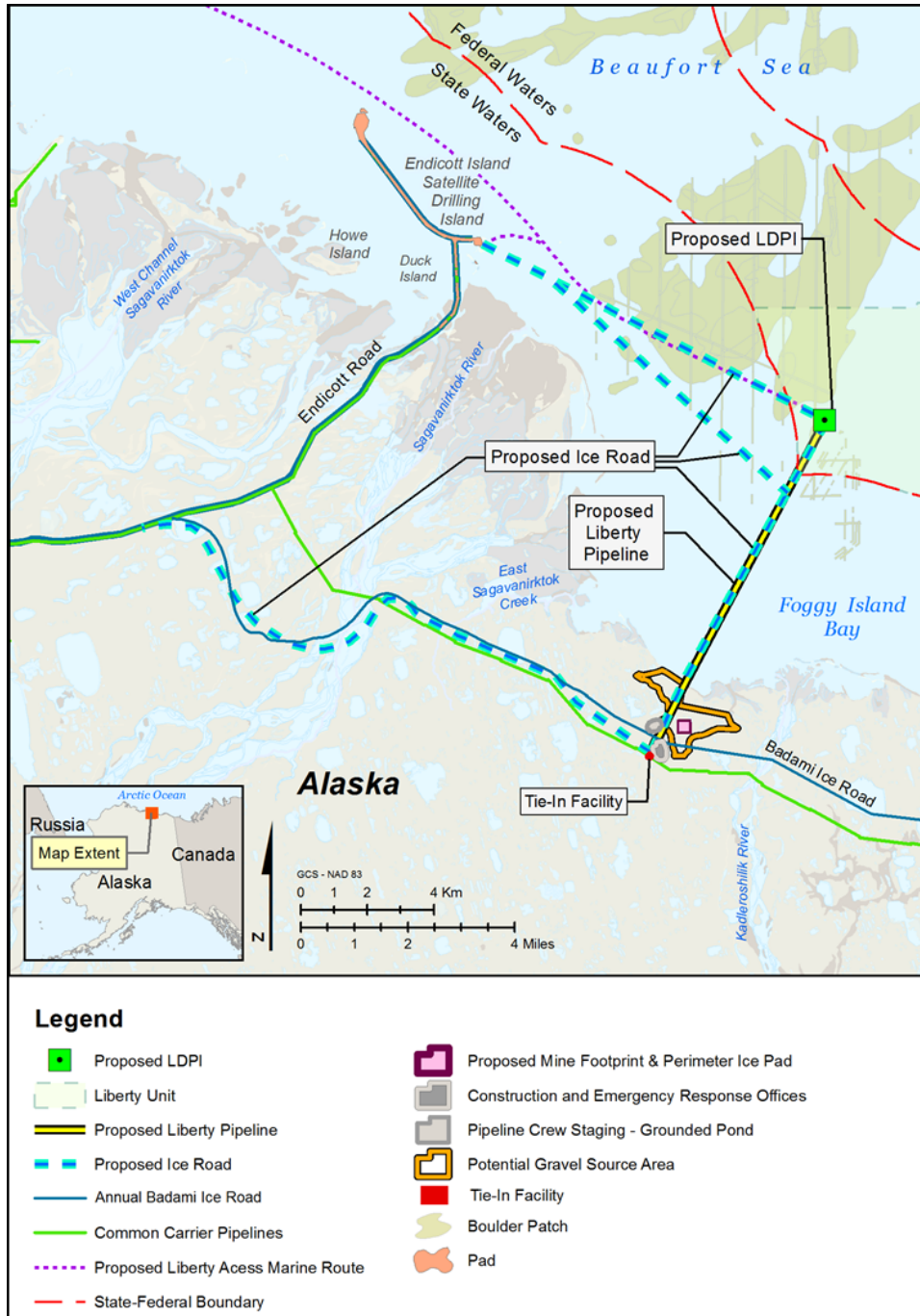

Figure ES-1. Proposed Action.

- Would have a design life of approximately 25 years (including surrounding infrastructure).

Associated onshore facilities and activities to support the Proposed Action would include ice road construction, construction of gravel pads to support the pipeline tie-in location and Badami ice road crossing, ice pad construction, construction of a hovercraft shelter and small boat dock, and development of a gravel mine site west of the Kadleroshilik River.

ALTERNATIVE 2 (NO ACTION)

Alternative 2 is the “No Action” Alternative. Under this Alternative, the Proposed Action would not be approved and the actions described in the Liberty DPP would not take place. No mineral resources would be extracted from the three leases comprising the Liberty Unit and none of the impacts or benefits described in Chapter 4 (Environmental Impacts) of the DEIS would be realized.

Under the No Action Alternative, there would be no need for other Federal or State permits or regulatory authorizations for activities described in the proposed DDP, e.g. NPDES permits, 404 permits, incidental take authorizations, etc.

All current oil and gas activity on the Beaufort Sea OCS and State waters, including the operations at Northstar, would continue as described in Chapter 5 (Cumulative Impacts) of the Draft EIS.

ALTERNATIVE 3 (ALTERNATE LDPI LOCATIONS)

BOEM developed two sub-alternatives based on public and Cooperating Agency comments to evaluate alternate LDPI locations that would minimize impacts to the Boulder Patch. After obtaining additional technical information from HAK concerning the feasibility of various alternative LDPI locations, BOEM identified two reasonable alternative LDPI locations for analysis in the EIS.

Alternative 3A would relocate the LDPI to a site approximately one mile to the east, which would result in the island being approximately this distance further away from the densest areas of the Boulder Patch. This alternative would place approximately 0.25 miles of the pipeline into an area with 100% possibility of overflow occurrence (overflowing is the fluvial process that causes strudel scour; see Section 3.1.2.4 for more information) that would require pipeline design changes to limit the risk of wear or upheaval buckling.

Alternative 3B places the LDPI approximately 1.5 miles closer to shore (which would be into State of Alaska waters). This Alternative moves the LDPI approximately one mile further away from the densest areas of the Boulder Patch. This alternative would increase the length of all wellbores by about 3,300 ft, to an average length of approximately 17,200 ft, as compared to an average wellbore length of approximately 13,900 ft for the Proposed Action.

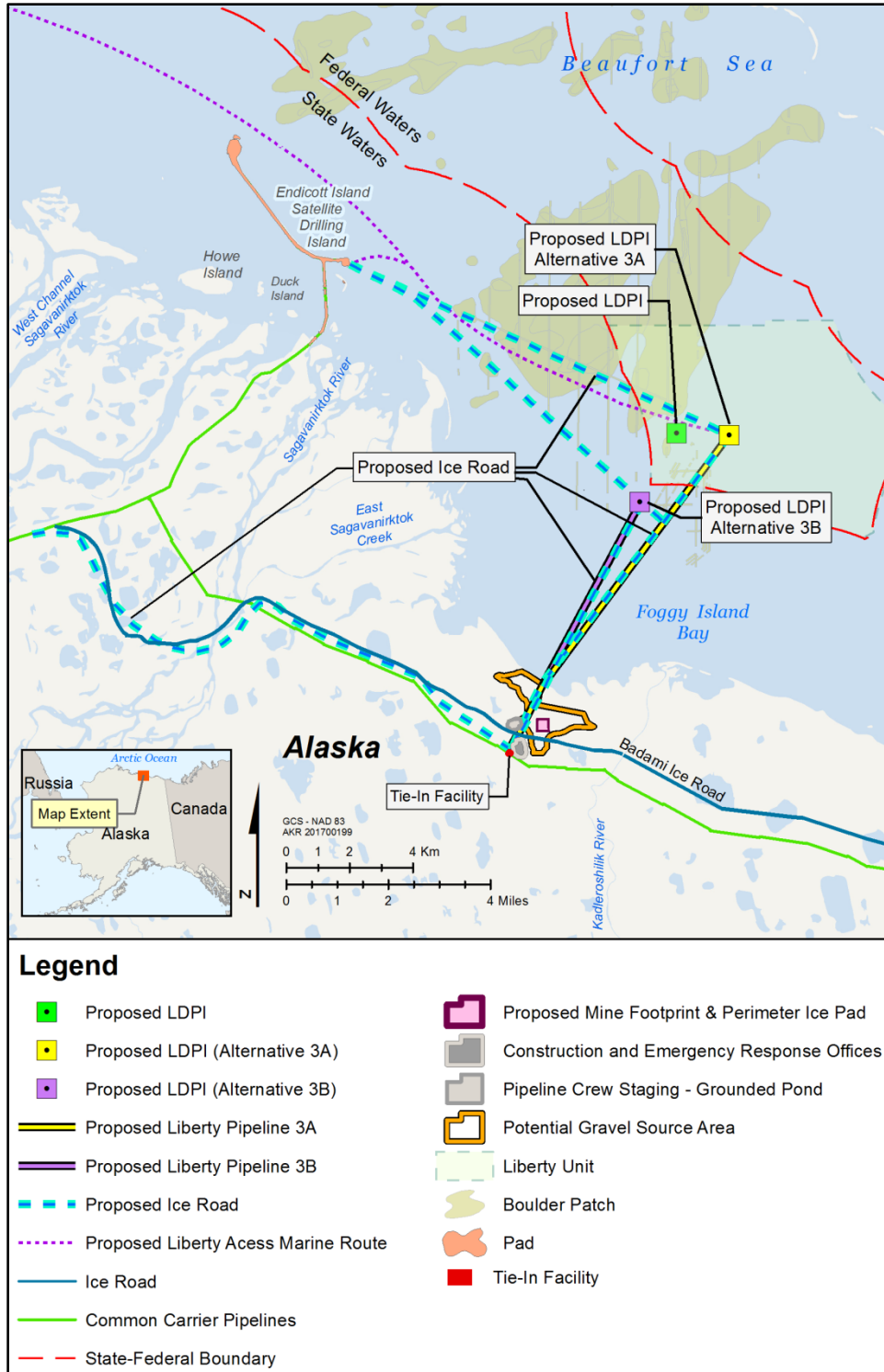

Figure ES-2. Alternative 3.

ALTERNATIVE 4 (RELOCATE OIL AND GAS PROCESSING OFF OF LDPI)

This Alternative also has 2 subalternatives. Alternative 4A would move oil and gas processing facilities from the LDPI to the existing Endicott SDI facility. Alternative 4B would move oil and gas processing facilities from the LDPI to a new onshore facility.

Both subalternatives match the Proposed Action in that the LDPI would be constructed and house wells to access the reservoir, and a pipeline would still be necessary to transport fluid to shore. They differ from the Proposed Action in that fluid transported via pipeline from the LDPI would be an unprocessed solution of oil, gas, water, and other constituents (termed a 3-phase line) as opposed to processed oil.

These alternatives were developed as a result of scoping comments suggesting that onshore processing may minimize impacts to marine resources and subsistence harvest practices from on-island equipment noise and vibration.

ALTERNATIVE 5 (ALTERNATE GRAVEL SOURCES)

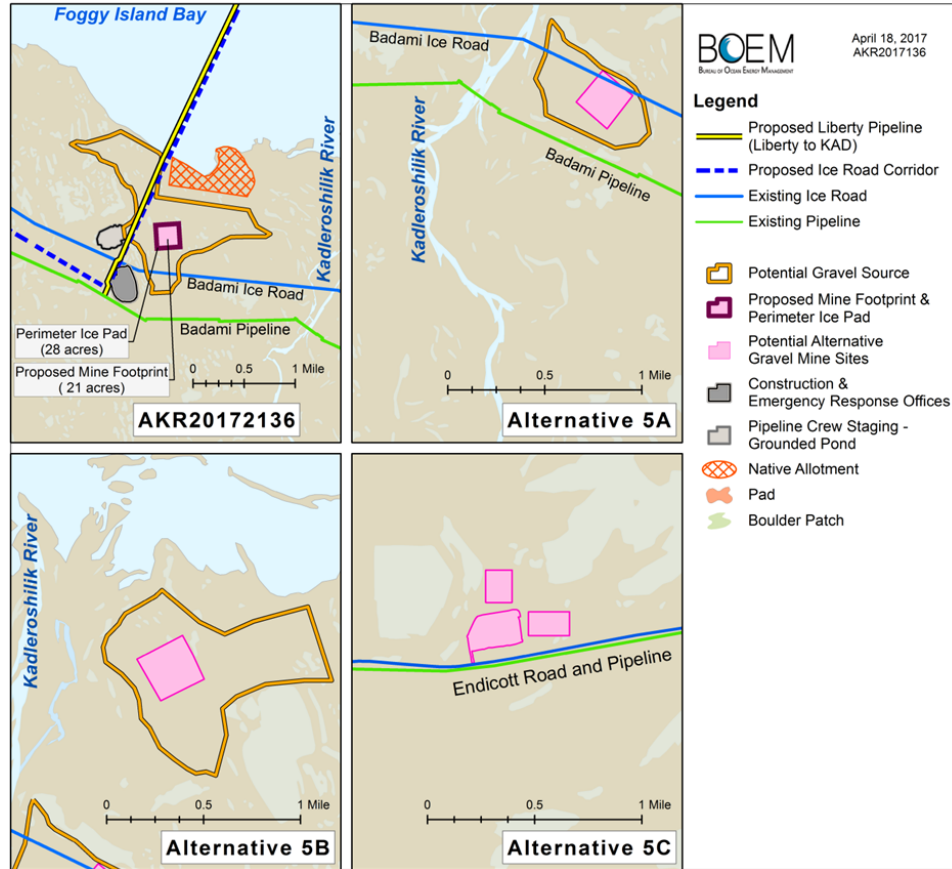

Figure ES-3. Alternative Gravel Mine Locations.

There are 3 subalternatives in Alternative 5. Each considers a different proposed gravel mine site location. (Figure 2.2.5-1)

These subalternatives were developed in response to scoping comments suggesting BOEM analyze an alternate location for the proposed West Kadleroshilik River Mine Site to minimize impacts to migratory birds, wetlands, fish used for subsistence purposes, and other resources. BOEM identified three feasible alternate locations based on a thorough review of existing technical and survey information.

ALTERNATIVES CONSIDERED BUT NOT CARRIED FORWARD FOR FURTHER ANALYSIS

Several potential alternatives suggested during scoping are not considered for detailed analysis in the DEIS because they are not reasonable alternatives as defined under NEPA. These included:

Ultra Extended Reach Drilling (uERD) from shore to the Liberty Reservoir. This alternative is not technically feasible because it would involve drilling a uERD well that would extend almost a mile beyond the existing world record of 40,602 feet for the longest wellbore.

Horizontally Directionally Drilling (HDD) the pipeline landfall. An HDD of this type would be a project not based on or in accordance with typical HDD projects; shore approaches using HDD are more complex than typical surface-to-surface HDD installations. This alternative would be the largest HDD project ever attempted in Alaska and is not technically feasible.

Seabed Gravel Mine. An alternative suggested during public scoping was to use gravel mined from the Federal OCS seabed to construct the LDPI during the open-water season. The technical and economic feasibility of this alternative is speculative; it is unknown whether the Beaufort Sea OCS (or other portions of the Alaska OCS) features a suitable gravel source. Additionally, the costs and environmental impacts of dredging and barging this gravel to the LDPI site would far exceed those from mining and trucking gravel from the proposed onshore mine located less than ten miles away. Further, prior analyses have indicated that this alternative would likely create unacceptable environmental and social impacts.

AFFECTED ENVIRONMENT

The Affected Environment chapter of the Draft EIS describes the physical and biological environment, socioeconomic and sociocultural systems, and oil and gas and related infrastructure of the Alaska Beaufort Sea shelf and Foggy Island Bay that could be affected by the Proposed Action. The following topics are included in this chapter:

- Bathymetry and Physiography
- Oceanography
- Oil and Gas Geology
- Water quality
- Air quality
- Climate Change
- Lower trophic level organisms
- Fish and shellfish
- Marine and coastal birds
- Marine mammals
- Terrestrial mammals
- Vegetation, Wetlands, and Substrate
- Sociocultural systems
- Economy
- Subsistence Activities and Harvest Patterns
- Public and community health
- Environmental justice
- Archaeological and historic resources

ENVIRONMENTAL CONSEQUENCES.

Impacts to each resource category were rated as negligible, minor, moderate, or major using impact scale definitions based on the context and intensity of impact. Separate ratings were produced for routine activities, small spills (<1,000 barrel (bbl)), and a large spill (\geq 1,000 bbl).

Potential impacts to environmental resource categories from the Proposed Action are summarized in Table ES-1. Potential impacts to environmental resource categories from the various Alternatives are summarized in Table ES-2.

Table ES-1. Potential Impacts of the Proposed Action by Resource.

Resource	Proposed Action Impact
Oil and Gas Geology	BOEM's independent reservoir model and reservoir simulation studies using Hilcorp's development plan indicate that the Liberty Field reservoir would recover from 41% to 48% of the 180 million barrels of oil (MMBO) originally in place. These studies indicate a peak production rate of approximately 58,000 barrels of oil per day (BOPD) within the first two years of production with an estimated Proposed Action life of 22 years.
Water Quality	Overall impacts to water quality caused by water extraction, construction of ice roads and pads, gravel mining, onshore gravel pad construction, construction of the LDPI, and placement of the subsea pipeline would be negligible (with mitigation) to minor.
Air Quality	Routine activities under the Proposed Action would result in low to medium intensity impacts to Air Quality due to one of the modeled pollutants being estimated at >50% but <100% of the NAAQS. Impacts would be temporary and localized over the 25-year lifetime of the Proposed Action and overall impacts to Air Quality would be minor.
Climate Change	The activities under the Proposed Action and its alternatives would produce GHG emissions, including carbon dioxide (CO ₂), methane (CH ₄), and nitrous oxide (N ₂ O). These GHG emissions would contribute to climate change.
Lower Trophic Organisms	Impacts to the Boulder Patch from routine activities as a result of the Proposed Action are expected to be moderate. Impacts would be mostly short-term and localized; the presence of the LDPI would be long-term, but general impacts would be minor and would have little to no negative impacts on benthic, epontic, and pelagic communities. Impacts from routine activities on resources outside of the Boulder Patch would be minor. The Boulder Patch is likely to have long-term local impacts to its community structure, and recovery is expected to take at least a decade.
Fish	Impacts to fish from the Proposed Action would be short-term and localized. The presence of the LDPI would be long-term, but general impacts would be minor and would have little to no negative impacts on fish, and would eventually be eliminated. Impacts from routine activities in the Proposed Action would be minor.
Marine and Coastal Birds	An increase in nest predators, specifically ravens, Arctic and red foxes, and glaucous gulls is expected to accompany new infrastructure and increased human presence associated with the Proposed Action. Permanent (i.e., life-of-the-Proposed Action) structures including the LDPI and support pads and pipelines would provide long-term habitat enhancements for nest predators. Temporary presence of cranes and drill rigs would provide additional temporary perch and nest sites. Unmanaged predator levels may influence local population levels. Therefore the Proposed Action would have a minor to moderate level of impact on local populations of nesting shorebirds, waterfowl, loons, and passerines because predation levels are unlikely to be reduced to pre-construction levels, and though they may be localized would still potentially be long-lasting.
Marine Mammals	The level of effects from the Proposed Action on marine mammals would be negligible, with impacts caused only by activities occurring during the open-water season. None of the proposed activities would result in impacts to meaningful numbers of marine mammals. Accidental, unplanned occurrences such as vessel strikes or oil spills could have minor to moderate localized impacts. By incorporating all of the assumed mitigations described in Appendix C, the effects for all proposed activities would be kept at a negligible level of effects, regardless of variations in activity throughout the life of the Proposed Action.
Terrestrial Mammals	The level of effects to terrestrial mammals from the onshore components of the Proposed Action, including vehicle and aircraft noise and traffic, surface disturbance, and human presence, would be negligible.
Vegetation and Wetlands	The impacts of Proposed Action would result in minor impacts to wetlands and vegetation. The amount of wetlands/WOUS lost during the entire Proposed Action would be approximately 3–5 acres filled for onshore pads, and approximately 21 acres excavated for the gravel mine. The types of wetlands that would be lost are common in the area. These impacts would be characterized as localized, but long-term.
Economy	The Proposed Action is expected to have negligible beneficial effects on State employment, labor income, and revenues. The beneficial impacts on NSB employment and income are likely to range from negligible to minor, while the beneficial impacts on NSB revenues are expected to translate to moderate impacts on the NSB economy. The Proposed Action is likely to have little to no impact on the population base of the State of Alaska or the NSB. Overall, the Proposed Action is expected to have a negligible beneficial impact on the State economy and a negligible to moderate beneficial impact on the NSB economy.
Subsistence-Harvest Patterns	Potential adverse effects to Cross Island subsistence whalers from routine construction, development, production, and decommissioning are expected to be moderate to major for the duration of the Proposed Action. Impacts to Cross Island whaling from small spills of crude or refined oil are anticipated to be minor to major. LDPI slope protection work at the Proposed Action Area is expected to have minor impacts on seal hunting for Nuiqsut and Kaktovik and negligible impacts on seal hunting for Utqiaġvik. Other routine activities associated with the Proposed Action are not expected to have adverse effects on seal hunting for any North Slope community. BOEM expects negligible impacts to subsistence caribou hunting for Nuiqsut, Kaktovik, and Utqiaġvik from routine construction, development, production, and decommissioning activities associated with the Proposed Action. For Nuiqsut, Kaktovik, and Utqiaġvik, BOEM anticipates negligible impacts to subsistence fishing from routine construction, development, and production activities associated with the Proposed Action. BOEM anticipates negligible impacts to Nuiqsut's goose hunting season from routine construction, development, production, and decommissioning activities and negligible impacts to subsistence waterfowl hunting for harvesters from Utqiaġvik.
Sociocultural Systems	Negligible impacts to the sociocultural systems for Kaktovik and Utqiaġvik as a result of routine activities associated with the Proposed Action.
Public and Community Health	Availability of and access to subsistence foods and other local subsistence resources are critical determinants of community health and cultural well-being in the NSB. Potential impacts to community health from loss of subsistence bowhead harvests and other harvest opportunities could be moderate. Impacts of air pollution and emissions from routine construction, development, and production on community health are expected to be minor. BOEM anticipates negligible impacts on community health related to water quality. Beneficial impacts to community health from revenue and economic growth are expected to be negligible to moderate. Adverse impacts to community health related to economic growth would most likely be minor. Overall, impacts on community health as a result of the Proposed Action are anticipated to be negligible to moderate. Effects to community health from small accidental spills occurring during the life of the Proposed Action are expected to be minor.
Environmental Justice (EJ)	If The Proposed Action results in moderate to major impacts to Cross Island subsistence whaling or to the social organization, cultural values, and local institutions of Nuiqsut, it would result in disproportionately high and adverse impacts to Nuiqsut.
Archaeological Resources	The overall impacts of the Proposed Action to archaeological resources would be negligible unless an historic property or other as yet undiscovered site were to be inadvertently damaged during normal Proposed Action activities or inadvertently damaged or vandalized during oil spill cleanup. Impacts to archaeological resources would then be major.

Table ES-2. Comparison of Impacts to Resources by Alternative.

Resource	Proposed Action	No Action	Alternative 3	Alternative 4	Alternative 5
Oil and Gas Geology	41-48% recovery	No resource recovery	3A/B-Similar to Proposed Action (PA)	4a; 4B-Similar to PA	Same as PA
Water Quality	Negligible to minor	No impact	3A/B-Negligible to moderate	4A/B-Same as PA	5A/B/C-Same as PA
Air Quality	Minor	No impact	3A-Moderate; 3B-Moderate to major	4A/B-Same as PA	5A/B/C-Same as PA
Climate Change	GHG emissions, including carbon dioxide (CO ₂), methane (CH ₄), and nitrous oxide (N ₂ O) would contribute to climate change	No additional GHG emissions	GHG emissions, including carbon dioxide (CO ₂), methane (CH ₄), and nitrous oxide (N ₂ O) would contribute to climate change	GHG emissions, including carbon dioxide (CO ₂), methane (CH ₄), and nitrous oxide (N ₂ O) would contribute to climate change	GHG emissions, including carbon dioxide (CO ₂), methane (CH ₄), and nitrous oxide (N ₂ O) would contribute to climate change
Lower Trophic Organisms	Moderate	No impact	3A/3B-Same as PA	4A/B-Same as PA	5A/B/C-Same as PA
Fish	Minor	No impact	3A/B- Same as PA	4A/B-Same as PA	5A/B/C-Same as PA
Marine and Coastal Birds	Minor to Moderate	No impact	3A/B- Same as PA	4a/4B-Same as PA	5A/B/C-Same as PA
Marine Mammals	Negligible	No impact	3A/B- Same as PA	4a/4B-Same as PA	5A/B/C-Same as PA
Terrestrial Mammals	Negligible	No impact	3A/B- Same as PA	4a-Same as PA; 4B-Moderate	5A/B/C-Same as PA
Vegetation and Wetlands	Minor	No impact	3A/B- Same as PA	4a-Same as PA; 4B-Moderate	5A/B/C-Same as PA
Economy	Negligible	Negligible	3A/B- Same as PA	4a-Same as PA; 4B-Moderate	5A/B/C-Same as PA
Subsistence-Harvest Patterns	Cross Island subsistence whalers- moderate to major; Minor impacts- seal hunting, Nuiqsut and Kaktovik; negligible impacts- seal hunting, Utqiagvik; negligible impacts- caribou hunting and fishing, Nuiqsut, Kaktovik, and Utqiagvik; negligible impacts- goose hunting, Nuiqsut; negligible impacts- waterfowl hunting for Utqiagvik	No impact	3A-Moderate to Major; 3B-Minor	4A/B-Negligible to moderate	5A/B-Same as PA; 5C-Moderate to major
Sociocultural Systems	Moderate to major	No impact	3A/B-Same as PA	4A/B-Same as PA	5A/B/C-Same as PA
Public and Community Health	Negligible to moderate	No impact	3A-Moderate to major; 3B-negligible	4A/B- Same as PA	5A/B-Minor to moderate; 5C-Moderate to major
Environmental Justice (EJ)	If major effects to sociocultural, then disproportionately high and adverse impacts to the Nuiqsut	No impact	3A-Same as PA; 3B-Not expected to have disproportionately high and adverse impacts	4A/B- Not expected to have disproportionately high and adverse impacts	5A/B/C- Same as PA
Archaeological Resources	Negligible, unless an historic property or undiscovered site inadvertently damaged-- then major	Negligible	3A/B-Same as PA	4A/B-Same as PA	5A/B/C- Same as PA

VERY LARGE OIL SPILL (VLOS) SCENARIO AND EFFECTS

A VLOS is not estimated to occur during the life of the Proposed Action and would be considered well outside the normal range of probability, despite the inherent hazards of oil development related activities. The Draft EIS references a hypothetical VLOS volume of 4.6 MMbbl, which is based on Hilcorp's estimate of a worst case discharge (WCD) volume which was independently verified by BOEM. The hypothetical VLOS discharge quantity is "conditioned" upon the assumption that all of the necessary chain of events required to create the VLOS actually occur (appropriate geology, operational failures, escaping confinement measures, the spill reaching the environment, etc.). In the unlikely event that a VLOS were to occur in the Beaufort Sea, the potential for significant effects on all resource categories would be high. Significant adverse impacts could potentially occur to components (e.g., species) within all examined environmental resource categories.

CUMULATIVE EFFECTS

Cumulative effects are assessed by determining the incremental impact of an action when added to the impacts of past, present, and reasonably foreseeable future actions in the vicinity of the Proposed Action. Actions considered in the cumulative effects analysis include other oil and gas activities, community development, recreation and tourism, marine vessel traffic, aircraft traffic, subsistence activities, research and survey activities, mining projects, and military activities. The analysis also considers climate change and its ongoing role in the changing Arctic ecosystem.

The incremental contribution from the Proposed Action (including accidental small oil spills) to the cumulative effects would likely be negligible to minor for all analyzed resources.

An accidental large oil spill, should one occur, would contribute additional cumulative effects. The resources with the greatest potential to experience cumulative effects include marine mammals, birds, coastal and estuarine habitats, subsistence harvesting patterns, and sociocultural systems.

CONSULTATION AND COORDINATION

BOEM is consulting with several Federal regulatory agencies, federally recognized tribes, and ANCSA corporations regarding the Liberty Development and Production Plan. Below is a brief summary of how BOEM has satisfied, or will satisfy, its consultation requirements with respect to the Liberty Development and Production Plan (the Proposed Action):

Executive Order 13175 – Tribal Consultation. BOEM is holding ongoing consultations with potentially affected tribal governments and ANCSA Corporations at multiple steps in the decision-making process. (BOEM will engage in another round of consultations with potentially affected tribes and ANCSA Corporations following release of the Draft EIS.)

Endangered Species Act – Section 7 Consultation. BOEM is consulting with NMFS and USFWS concerning potential impacts to endangered and threatened species and their designated critical habitat.

Magnuson-Stevens Fishery Conservation and Management Act – Essential Fish Habitat Consultation. BOEM will provide an EFH assessment to the National Marine Fisheries Service (NMFS) regarding the potential effects on EFH for all five species of Pacific salmon, as well as Arctic cod and saffron cod.

National Historic Preservation Act – Section 106 Consultation. BOEM has sent a letter to the State of Alaska, State Historic Preservation Officer seeking concurrence that the Proposed Action would not affect any known historic properties..

APPENDICES

Appendix A. Accidental Oil Spills and Gas Releases

Appendix A discusses the technical information used to estimate numbers and volumes of oil spills and natural gas releases assumed to occur over the life of the Scenario. The rationale for these assumptions is a mixture of Proposed Action-specific information, modeling results, statistical analysis, three decades of experience modelling hypothetical oil spills, and professional judgment.

Appendix B: Air Quality Analysis Methodology

Appendix B provides the data, assumptions, and emission factors used in analyzing air quality effects in this EIS.

Appendix C. Design Features and Mitigation Measures

Appendix C discusses in greater detail the various Proposed Action design features and mitigation measures which are expected to reduce potential impacts from the Proposed Action to the resources analyzed in this DEIS. These mitigation measures include Lease Stipulations, typical mitigation measures incorporated into Marine Mammal Protection Act take authorizations, and typical mitigation measures incorporated into Biological Opinions issued pursuant to Section 7 of the ESA. The impacts analysis in this DEIS assumes that all measures described in Appendix C would be required and enforced. Appendix C also contains proposed mitigation measures that were developed as a result of scoping comments or through impacts analysis.

Appendix D. Draft Liberty Baseline Human Health Summary

Appendix D presents an overview of the current health status of the communities within the North Slope Borough (NSB). This baseline health summary included Anaktuvuk Pass, Atqasuk, Kaktovik, Nuiqsut, Point Hope, Point Lay, Utqiagvik [formerly known as Barrow], and Wainwright. This baseline health summary refers to these communities as potentially affected communities (PACs) in accordance with the HIA Toolkit (ADHSS, 2015). The summary focused on Nuiqsut because it is the closest PAC to the Proposed Action.

Appendix E. Wetlands Delineation Report

Appendix E, the Wetlands and Waters of the United States (WOUS) Delineation Report, supports Hilcorp Alaska, LLC's (Hilcorp's) Liberty Development Program, east of Deadhorse, Alaska. The report discusses the location and extent of wetlands and other WOUS in the Proposed Action Area which are potentially subject to the jurisdiction of the United States Army Corps of Engineers (USACE) under Section 10 of the Rivers and Harbors Act and Section 404 of the Clean Water Act (CWA).

Appendix F. Lease Stipulations

Appendix F contains the Lease stipulations that apply to each of the Liberty Unit constituent lease sales. Narrative translations of obsolete terminology and the current authorizing regulations is provided as necessary within this DEIS and appendices.

Table of Contents

This page intentionally left blank

Table of Contents

Title Page	i
Cover Sheet.....	ii
Acronyms and Abbreviations	iii
Executive Summary	ES-1
Introduction and Background	ES-1
Purpose and Need for the Proposed Action.....	ES-1
Regulatory and Administrative Framework	ES-2
Scoping.....	ES-2
Proposed Action and Alternatives	ES-2
Alternative 2 (No Action)	ES-4
Alternative 3 (Alternate LDPI locations)	ES-4
Alternative 4 (Relocate Oil and Gas Processing off of LDPI)	ES-5
Alternative 5 (Alternate Gravel Sources).....	ES-6
Alternatives Considered But Not Carried Forward for Further Analysis.....	ES-6
Affected Environment	ES-7
Environmental Consequences.	ES-7
Very Large Oil Spill (VLOS) Scenario and Effects	ES-11
Cumulative Effects	ES-11
Consultation and Coordination.....	ES-11
Appendices	ES-12
Chapter 1. Proposed Action	1-1
1.1. Background	1-1
1.2. Proposed Action	1-3
1.3. Purpose and Need for the Proposed Action.....	1-3
1.4. Regulatory and Administrative Framework	1-4
1.4.1. BOEM Regulatory Authorities.....	1-5
1.4.2. EPA Regulatory Authorities.....	1-7
1.4.3. USACE Regulatory Authorities:	1-8
1.4.4. NMFS Regulatory Authorities	1-9
1.4.5. USFWS Regulatory Authorities	1-11
1.4.6. PHMSA statutory authority.....	1-11
1.4.7. SOA regulatory requirements.....	1-11
1.4.8. BSEE Regulatory Authorities	1-11
1.4.9. BSEE Permitting Responsibilities and Oversight	1-11
Chapter 2. Proposed Action and Alternatives	2-1
2.1. Proposed Action	2-1
2.1.1. Winter & Summer Access	2-4
2.1.2. Gravel Mine Site Development	2-9
2.1.3. Liberty Development and Production Island Construction	2-12
2.1.4. Pipeline Construction	2-13
2.1.5. Facilities Construction.....	2-18
2.1.6. Drilling Operations.....	2-19
2.1.7. Production Operations.....	2-20
2.1.8. Decommissioning.....	2-21

2.1.9. EPA Permitting	2-23
2.1.10. USACE Permitting	2-27
2.1.11. NMFS Permitting	2-28
2.2. Alternatives	2-29
2.2.1. Alternatives Selection Process	2-29
2.2.2. Alternative 1 (Proposed Action).....	2-31
2.2.3. Alternative 2 (No Action).....	2-32
2.2.4. Alternative 3 (Alternate LDPI locations)	2-32
2.2.5. Alternative 4 (Alternate Processing Locations)	2-38
2.2.6. Alternative 5 (Alternate Gravel Sources).....	2-48
2.2.7. Alternative Comparison Tables.....	2-53
2.3. Alternatives Considered but Not Carried Forward for Further Analysis.....	2-58
2.3.1. Ultra-Extended Reach Drilling (uERD).....	2-58
2.3.2. Horizontally Directional Drilling (HDD) Pipeline Landfall	2-59
2.3.3. OCS Gravel Mining and Summer LDPI Construction.....	2-61
2.4. Mitigation	2-61
2.4.1. Proposed Mitigation Measure	2-61
Chapter 3. Description of the Environment	3-1
3.1. Physical Environment.....	3-1
3.1.1. Bathymetry and Physiography	3-1
3.1.2. Oceanography.....	3-1
3.1.3. Oil and Gas Geology	3-9
3.1.4. Water Quality	3-12
3.1.5. Air Quality.....	3-19
3.1.6. Climate Change	3-22
3.2. Biological Environment.....	3-30
3.2.1. Lower Trophic Level Organisms	3-30
3.2.2. Fish.....	3-32
3.2.3. Birds	3-36
3.2.4. Marine Mammals	3-50
3.2.5. Terrestrial Mammals	3-108
3.2.6. Vegetation, Wetlands and Substrate.....	3-120
3.3. Sociocultural Systems	3-124
3.3.1. Sociocultural Systems	3-124
3.3.2. Economy.....	3-126
3.3.3. Subsistence Activities and Harvest Patterns.....	3-129
3.3.4. Community Health	3-145
3.3.5. Environmental Justice	3-152
3.3.6. Archaeological Resources	3-156
Chapter 4. Environmental Consequences	4-1
4.1. Introduction and Background for Analysis	4-1
4.1.1. Accidental Oil Spills, Exercises and Drills, and Gas Release Estimation.....	4-1
4.1.2. Impacts Scale.....	4-8
4.2. Physical Environment.....	4-9
4.2.1. Oil and Gas Geology/Petroleum Engineering	4-9
4.2.2. Water Quality	4-13

4.2.3. Air Quality.....	4-31
4.2.4. Climate Change.....	4-49
4.3. Biological Environment.....	4-52
4.3.1. Lower Trophics	4-52
4.3.2. Fish.....	4-64
4.3.3. Birds	4-75
4.3.4. Marine Mammals	4-104
4.3.5. Terrestrial Mammals	4-199
4.3.6. Vegetation, Wetlands, and Substrate.....	4-223
4.4. Sociocultural Systems	4-231
4.4.1. Sociocultural Systems	4-231
4.4.2. Economy.....	4-240
4.4.3. Subsistence Activities and Harvest Patterns.....	4-250
4.4.4. Community Health	4-284
4.4.5. Environmental Justice	4-294
4.4.6. Archaeological Resources	4-297
4.5. Very Large Oil Spill Scenario	4-303
4.5.1. Background	4-303
4.5.2. OCS Well Control Incidents.....	4-303
4.5.3. Hypothetical VLOS Scenario	4-304
4.5.4. Fate and Behavior of an Oil Spill.....	4-308
4.5.5. Hypothetical VLOS Conditional Probabilities and Trajectory Modeling	4-311
4.5.6. Gas Release	4-312
4.6. Recovery and Cleanup.....	4-312
4.6.1. Scenario Phases and Impact Producing Factors	4-314
4.6.2. Opportunities for Prevention, Intervention, and Response	4-316
4.7. Effects of a Very Large Oil Spill (VLOS).....	4-319
4.7.1. Effects of a VLOS on Water Quality	4-319
4.7.2. Effects of a VLOS on Air Quality.....	4-325
4.7.3. Effects of a VLOS on Lower Trophic Level Organisms.....	4-329
4.7.4. Effects of a VLOS on Fish	4-334
4.7.5. Effects of a VLOS on Birds	4-340
4.7.6. Effects of a VLOS on Marine Mammals.....	4-348
4.7.7. Effects of a VLOS on Terrestrial Mammals.....	4-390
4.7.8. Effects of a VLOS on Vegetation and Wetlands.....	4-395
4.7.9. Effects of a VLOS on Sociocultural Systems.....	4-402
4.8. Unavoidable Adverse Effects	4-414
4.9. Relationship between Local Short-Term Uses and Maintenance and Enhancement of Long-Term Productivity	4-415
4.10. Irreversible and Irretrievable Commitment of Resources	4-415
Chapter 5. Cumulative Effects	5-1
5.1. Introduction	5-1
5.1.1. Framing the Analysis	5-1
5.1.2. Past, Present, and Reasonably Foreseeable Future Actions	5-2
5.1.3. Climate Change	5-15
5.2. Analysis of Cumulative Effects.....	5-15
5.2.1. Water Quality	5-15

5.2.2. Air Quality.....	5-18
5.2.3. Lower Trophic Organisms.....	5-21
5.2.4. Fish.....	5-23
5.2.5. Birds.....	5-25
5.2.6. Marine Mammals.....	5-28
5.2.7. Terrestrial Mammals.....	5-40
5.2.8. Vegetation and Wetlands.....	5-47
5.2.9. Sociocultural Systems.....	5-49
5.2.10. Economy.....	5-50
5.2.11. Subsistence-Harvest Patterns.....	5-54
5.2.12. Community Health.....	5-58
5.2.13. Environmental Justice.....	5-59
5.2.14. Archaeological Resources.....	5-61
Chapter 6. Consultation, Coordination, Preparer List.....	6-1
6.1. Development of this DEIS.....	6-1
6.2. Consultation.....	6-1
6.2.1. Tribal Consultation.....	6-1
6.2.2. ESA Section 7.....	6-1
6.2.3. Essential Fish Habitat Consultation.....	6-2
6.2.4. Section 106, National Historic Preservation Act Consultation.....	6-2
6.3. Document Preparers.....	6-2

The Proposed Action

This page intentionally left blank

Table of Contents

Chapter 1. Proposed Action.....	1-1
1.1. Background.....	1-1
1.2. Proposed Action.....	1-3
1.3. Purpose and Need for the Proposed Action	1-3
1.4. Regulatory and Administrative Framework.....	1-4
1.4.1. BOEM Regulatory Authorities	1-5
1.4.2. EPA Regulatory Authorities	1-7
1.4.3. USACE Regulatory Authorities:	1-8
1.4.4. NMFS Regulatory Authorities.....	1-9
1.4.5. USFWS Regulatory Authorities	1-11
1.4.6. PHMSA statutory authority	1-11
1.4.7. SOA regulatory requirements	1-11
1.4.8. BSEE Regulatory Authorities.....	1-11
1.4.9. BSEE Permitting Responsibilities and Oversight.....	1-11

List of Figures

Figure 1.1-1 Existing Liberty Exploration Wells.....	1-1
Figure 1.2-1. Proposed Liberty Island Development and Production Area	1-4
Figure 1.4-1. Four Stages of the OCSLA Oil and Gas Process.....	1-6

This page intentionally left blank

CHAPTER 1. PROPOSED ACTION

1.1. Background

This chapter describes the Proposed Action, the Purpose and Need for the Proposed Action, and the Federal regulatory and administrative context for preparing this Alaska Outer Continental Shelf (OCS) Beaufort Sea Liberty Development and Production Plan (DPP) Draft Environmental Impact Statement (DEIS).

The Liberty Unit, for which Hilcorp Alaska, LLC (HAK) is the designated operator, was formed in 2003 to include OCS-Y-1650 and OCS-Y-1585. In 2016, the Bureau of Safety and Environmental Enforcement (BSEE) approved the expansion of the unit to include OCS-Y-1886; this is a small sliver (2.7 acres of OCS acreage) which arose following the mapping conversion from North American Datum—NAD— 1927 to NAD 1983. These leases were attained under Lease Sales 124 in 1991, 144 in 1996, and 202 in 2007.

Hilcorp submitted the Liberty DPP to the Bureau of Ocean Energy Management (BOEM) on December 30, 2014. BOEM made several requests for additional information on the DPP throughout 2015. HAK responded to these requests with a plan revision on September 8, 2015. BOEM deemed the DPP submitted (i.e., complete) on September 18, 2015.

The Liberty prospect has been subject to several proposed project designs and National Environmental Policy Act (NEPA) reviews since its discovery over 30 years ago. A brief history of the project is described below to provide context for this current DPP DEIS.

Five exploration wells are shown along with lease boundaries and offset wells in Figure 1.1-1.

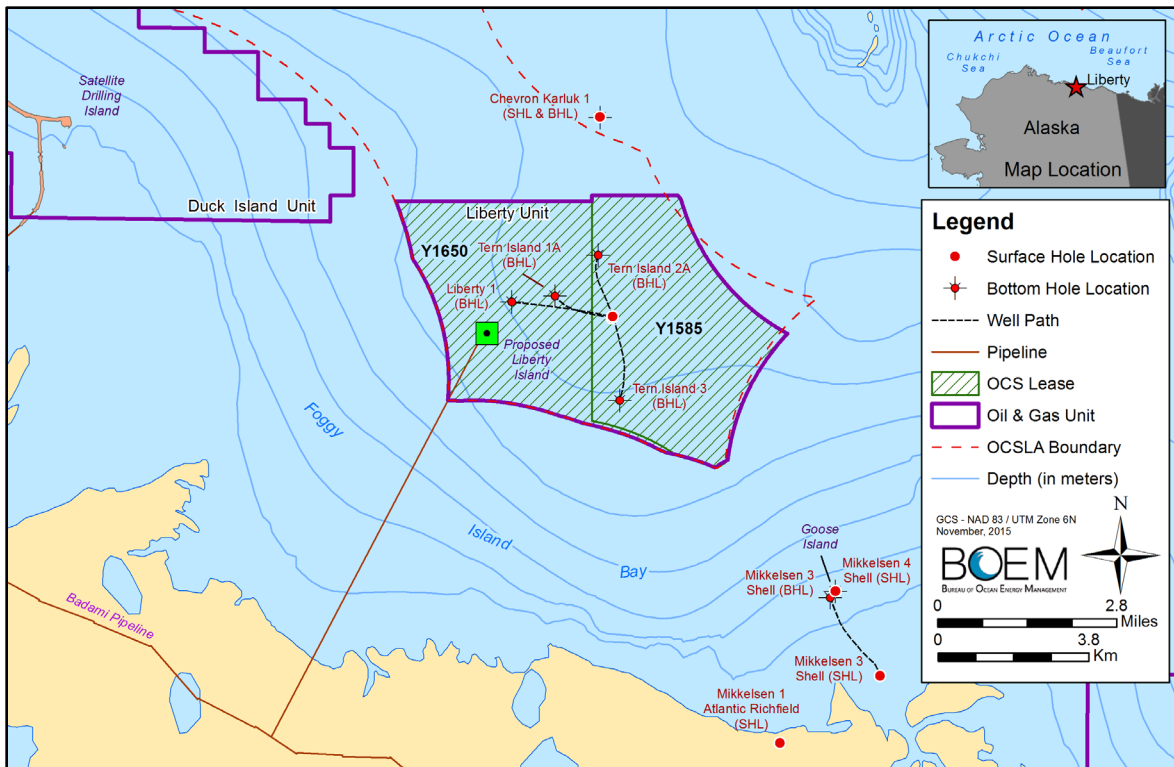

Figure 1.1-1 Existing Liberty Exploration Wells.

The Liberty Reservoir was first discovered by Shell Oil Company. Shell drilled four wells between 1982 and 1987 to evaluate the potential of the Kekiktuk Formation in Foggy Island Bay. Three of the

wells (Tern Island wells 1A, 2A, and 3) were drilled from Tern Island, which Shell constructed in 1981-1982. The fourth well was drilled from Goose Island, located southeast of Tern Island. In September 1996, BP Exploration Alaska (BPXA) acquired Tract OCS-Y-1650 in OCS Lease Sale 144, and initiated exploration permitting activity for the Liberty No. 1 Exploration Well. The surface location for this well was a gravel and ice structure situated on top of the abandoned Tern Island on Lease OCS-Y-1585 (Lease Sale 124), with the bottom-hole location (bottom of the drilled well) in Lease OCS-Y-1650. Tern Island is currently abandoned and eroding.

In February 1997, drilling of the Liberty No. 1 well began, followed by well testing in March 1997 and demobilization in April 1997. Based on interpretations of geologic data, seismic data, and well tests, BPXA confirmed the discovery of an estimated 120 million barrels (MMbbl) of recoverable reserves from the Liberty prospect on May 1, 1997. Since then, plans to develop the field have progressed through three stages, as described below.

1998 BPXA DPP

BPXA initiated conceptual engineering in 1996. This effort was based on assumed exploratory success and focused on identification and screening of project development alternatives. Factors considered in the evaluation of alternatives included reservoir development and recovery, environmental impacts, costs, technical complexity, and logistical practicalities. On February 17, 1998, BPXA submitted a DPP to the Minerals Management Service (MMS). This project included a man-made gravel island, on-island processing facilities, and a buried, single-wall subsea pipeline to shore and tie-in to the Badami pipeline. MMS initiated a regulatory review process and commenced preparation of an EIS. However, prior to a final MMS decision on the DPP, BPXA requested that the project be placed on hold. BPXA requested a Suspension of Production (SOP) on July 10, 2001, which MMS granted on July 19, 2001. MMS issued a final EIS (FEIS) concerning this DPP in May of 2002, but did not issue a Record of Decision.

2007 BPXA DPP

From 2002 to 2005, BPXA evaluated alternative ways to develop the oil accumulation at the Liberty site.

In August 2005, BPXA announced that it would pursue use of ultra-extended-reach drilling (uERD) from an onshore location to the existing satellite drilling island (SDI) on the Endicott causeway. The proposed land-based project was intended to eliminate the gravel island and subsea pipeline components of the prior DPP, for the stated purpose of mitigating impacts related to the Boulder Patch, marine mammals, and concerns related to subsistence whaling. It also made issues related to construction impacts and risk of an offshore pipeline design immaterial. This project was described in the April 2007 Liberty DPP. BOEM prepared an Environmental Assessment (EA) of the impacts of this DPP and issued a Finding of No Significant Impact (FONSI) in November 2007.

Following approval of this plan, BPXA expanded the Endicott SDI and constructed and positioned a drilling rig to drill the proposed wells. However, BPXA cancelled the uERD project in 2012 due to technical difficulties. BPXA requested another SOP in December 2012. BSEE granted the SOP under the condition that BPXA submit an actionable DPP to BOEM by December 31, 2014.

2015 HAK DPP

In 2012, BPXA began re-evaluating ways to develop the reservoir with an island over the reservoir and conventional drilling technology.

In April 2014, BPXA announced the sale of several North Slope assets to HAK including Northstar, Endicott, Milne Point, and Liberty. In the case of Liberty, 50% ownership and full operatorship of the field was to be transferred from BPXA to HAK upon closing the sale in late 2014.

HAK incorporated many of the concepts of the plan outlined in the 1998 BPXA DPP into its December 30, 2014, DPP.

1.2. Proposed Action

The Liberty Development would be a self-contained offshore drilling and production facility located on an artificial gravel island with a pipeline to shore. Infrastructure and facilities necessary to drill wells and process and export approximately 60,000 to 70,000 barrels of oil per day (BOPD) to shore would be installed on the island. There would be slots for 16 wells, which include accommodations for 5-8 producing wells, 4-6 water and/or gas injection wells, and up to two disposal wells at surface wellhead spacing of 15 feet (4.6 meters (m)) between wellheads. Produced gas would be used for fuel gas, artificial lift, or re-injection into the reservoir. Seawater would be treated and injected into the Liberty oil reservoir to increase pressure (in a process called waterflooding) which would increase the oil-production rate and, ultimately, the oil recovery. Following waterflood breakthrough, produced water would be commingled with seawater and re-injected for reservoir pressure support. A pipe-in-pipe system, consisting of a 12 inch (30.5 centimeters (cm)) sales oil pipeline inside a 16 inch (40.6 cm) outer pipe would transport crude oil to the Badami Sales Oil Pipeline. The offshore portion of the pipeline would be approximately 5.6 miles (9 kilometers (km)) long, and the overland portion would be approximately 1.5 miles (2.4 km) long to the Badami pipeline tie-in point.

Associated onshore activities to support the project would include use of permitted water sources, construction of gravel pads to support the pipeline tie-in location and Badami ice road crossing, ice roads and ice pad construction, hovercraft shelter, small boat dock, and development of a gravel mine site west of the Kadleroshilik River. Existing North Slope infrastructure, such as the Dalton Highway, support infrastructure at Deadhorse, the Trans-Alaska Pipeline (TAPS), and West Dock, would also be used to support this project. For a complete description of the Proposed Action, see Chapter 2 of this DEIS.

Land Status

The land adjacent to the U.S. Beaufort Sea is within the North Slope Borough (NSB), a political subdivision of the State of Alaska. Land-ownership in the NSB is complex. The Federal Government is the predominant land owner of onshore lands, with more than half of the Borough's land area encompassed by the National Petroleum Reserve in Alaska (NPR-A) and the Arctic National Wildlife Refuge (ANWR). Other major landholders include the State of Alaska, Arctic Slope Regional Corporation (ASRC), Kaktovik Iñupiat Corporation, and Kuukpik Corporation.

1.3. Purpose and Need for the Proposed Action

The purpose of the Proposed Action is to recover and process oil from the Liberty oil field and transport sales-quality oil to market. The need for this action is established by DOI's responsibility under the Outer Continental Shelf Lands Act (OCSLA) to make OCS lands available for expeditious and orderly development, subject to environmental safeguards, in a manner which is consistent with the maintenance of competition and other national needs. The OCSLA also specifies the submittal and review processes for proposed DPPs, and establishes the circumstances under which proposed DPPs are to be approved, modified, or disapproved.

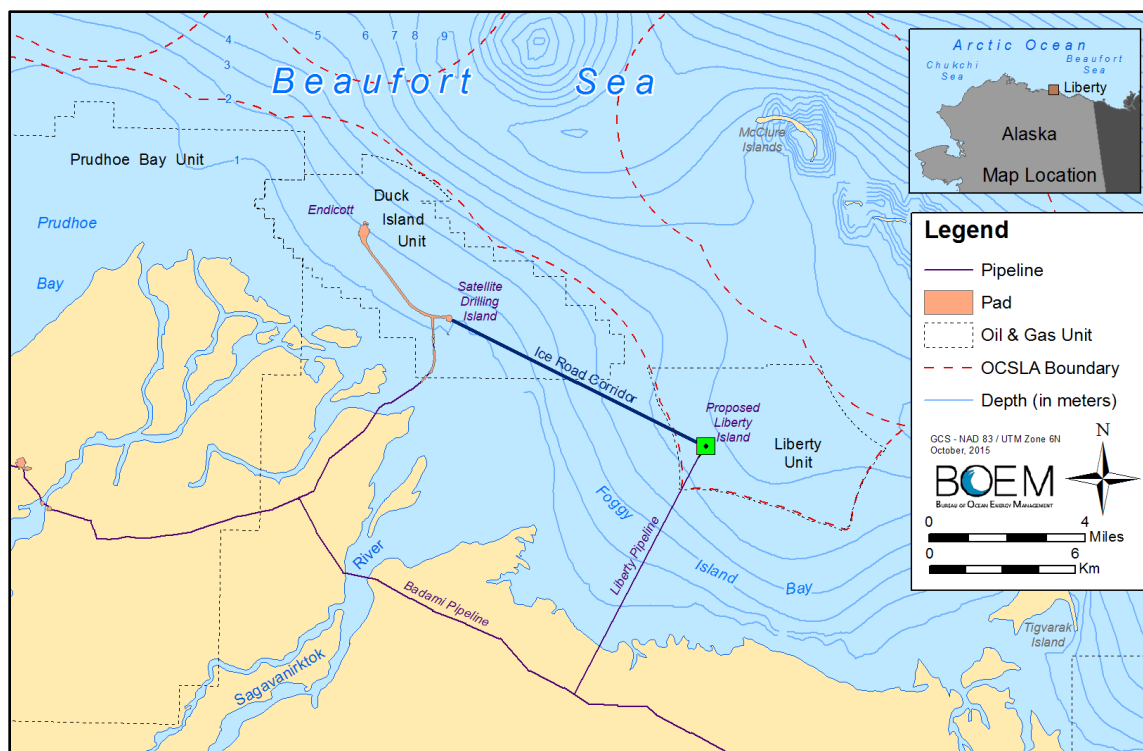

Figure 1.2-1. Proposed Liberty Island Development and Production Area. Figure shows the locations of the proposed production island, pipeline, and ice road route from Hilcorp's Satellite Drilling Island.

The DOI has delegated its OCSLA authority to several bureaus, including BOEM. BOEM is responsible for managing the mineral and energy resources located on the Nation's OCS in an environmentally sound and safe manner. To these ends, BOEM has promulgated regulations implementing certain provisions of OCSLA.

BOEM regulations pertaining to review of proposed DPPs are codified at 30 CFR Part 550, where BOEM establishes requirements for the submittal of the DPP, the DPP review process, and performance standards that the DPP must meet in order to be approved.

1.4. Regulatory and Administrative Framework

A number of other Federal agencies also have regulatory authority over aspects of the Proposed Action and are using this EIS to inform their respective regulatory reviews of those proposed activities. The Bureau of Safety and Environmental Enforcement (BSEE), the Environmental Protection Agency (EPA), the U.S. Army Corps of Engineers (USACE), and the National Marine Fisheries Service (NMFS) intend to adopt the Final EIS in order to satisfy the NEPA requirements associated with their pending regulatory decisions. The U.S. Fish and Wildlife Service (USFWS) and the Pipeline and Hazardous Materials Safety Administration (PHMSA) are using the environmental analysis contained herein to inform their various permitting and regulatory actions connected to the Proposed Action. This DEIS contains more detailed regulatory and permitting information about the agencies that intend to adopt the Final EIS.

The State of Alaska Department of Natural Resources (SOA DNR) also has regulatory authority over aspects of the Proposed Action and intends to use the EIS to help inform its regulatory review.

The regulatory and administrative authorities for each Federal and State agency, as well as the individual permitting requirements connected to the Proposed Action, are described below.

Although several of the regulatory authorities described below apply to multiple federal agencies, they are described only once.

1.4.1. BOEM Regulatory Authorities

1.4.1.1. Outer Continental Shelf Lands Act

Federal laws establish the OCS leasing program (e.g., OCSLA) and the plan-specific review processes. Under OCSLA, the USDOJ is required to manage the orderly leasing, exploration, development, production, and decommissioning of oil and gas resources on the Federal OCS while simultaneously ensuring protection of the human, marine, and coastal environments and assuring receipt of fair market value for the lands leased and the rights conveyed by the Federal government. OCSLA also requires coordination with states and local governments affected by OCS development activities.

OCSLA creates a four-stage process for planning, leasing, exploration, and production of oil and gas resources in Federal waters (Figure 1.4-1). OCSLA's four-stage oil and gas review process gives the Secretary a "continuing opportunity for making informed adjustments" in developing OCS energy resources to ensure all activities are conducted in an environmentally sound manner (Sierra Club v. Morton, 510 F.2d 813, 828 (5th Cir.1975)). In the first stage, the Secretary (through BOEM) prepares a five-year leasing program to identify the size, timing, and location of proposed lease sales, and prepares an environmental document under NEPA. In the second stage, BOEM conducts the prelease process for lease sale-specific NEPA reviews. If BOEM proceeds with a lease sale, BOEM conducts a sealed-bid auction, opens the bids it receives, evaluates the bids for fair market value, and issues the leases. The third stage involves exploration of the leased blocks. Prior to any exploratory drilling, a lessee must submit an exploration plan (EP) to BOEM for review and approval. The fourth stage, development and production, is reached if a lessee finds a commercially viable oil and/or gas discovery. For this stage, HAK has submitted a detailed DPP to BOEM. Statutory requirements for the submittal and review of proposed DPPs are provided in Section 25 of OCSLA (43 USC 1351). BOEM's implementing regulations pertaining to review of proposed DPPs are codified at 30 CFR Part 550. There, BOEM establishes the requirements for submitting DPPs, the process by which BOEM reviews DPPs, and performance standards that the DPP must meet in order to be approved. These performance standards, codified at 30 CFR 550.202 require that the operator's DPP demonstrate that it has planned and is prepared to conduct its proposed activities in a manner that:

- Conforms to OCSLA as amended, applicable implementing regulations, lease provisions and stipulations, and other Federal laws;
- Is safe;
- Conforms to sound conservation practices and protects the rights of the lessor;
- Does not unreasonably interfere with other users of the OCS, including those involved in National security or defense; and
- Does not cause undue or serious harm or damage to the human, marine, or coastal environment.

Pursuant to 43 USC 1351 and 30 CFR 550.270-.271, BOEM would approve the DPP if it complies with all applicable requirements. Conversely, BOEM would require modification of the DPP if it fails to make adequate provisions for safety, environmental protection, or conservation of natural resources or otherwise does not comply with the lease, OCSLA, the regulations prescribed under OCSLA, or other Federal laws. BOEM would disapprove the DPP if the operator failed to demonstrate that it can comply with applicable requirements, or if any of several other specified circumstances apply.

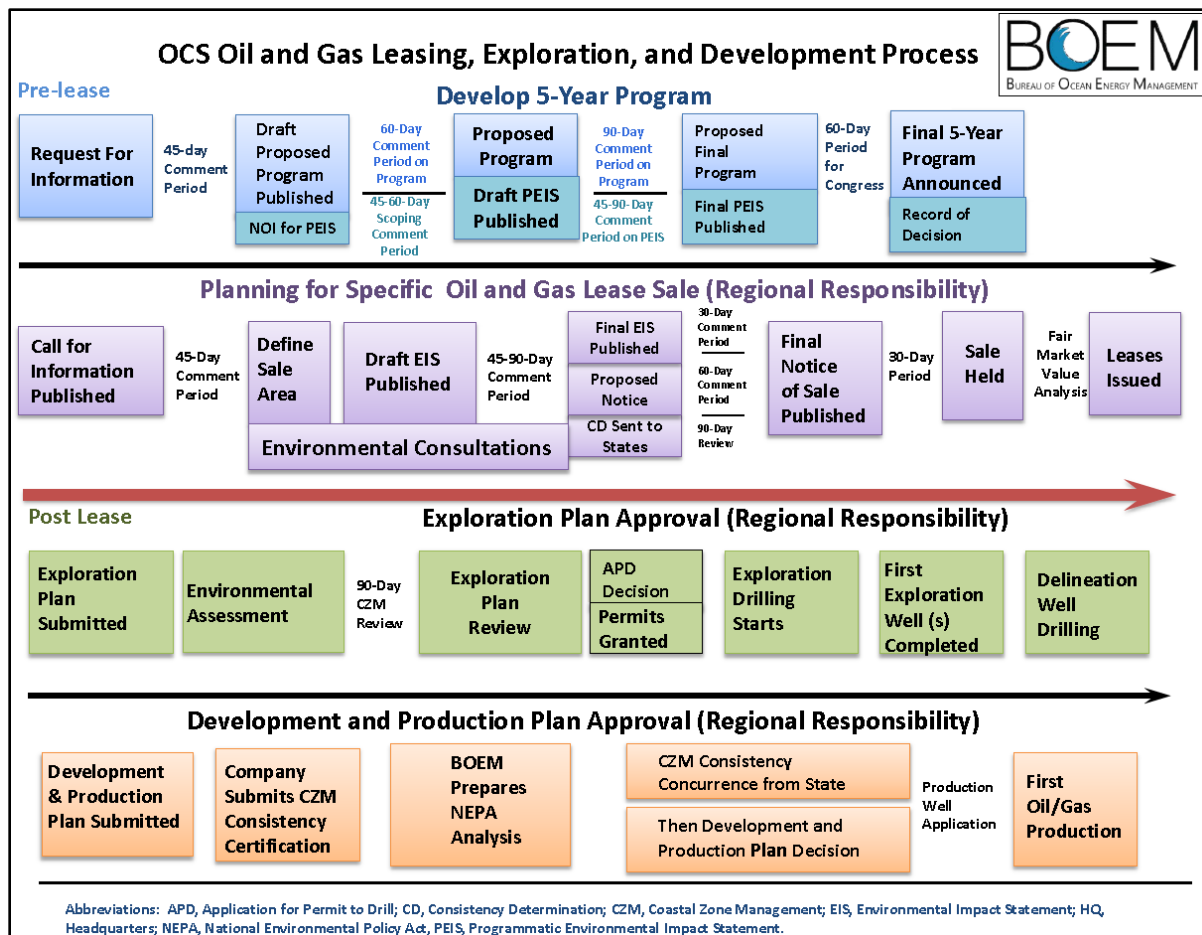

Figure 1.4-1. Four Stages of the OCSLA Oil and Gas Process.

1.4.1.2. Lease Stipulations

HAK must abide by the requirements of lease stipulations associated with the three Federal leases which make up the Liberty Unit. These leases were issued under three separate lease sales: Beaufort Sea Planning Area Lease Sale 124 (Lease OCS-Y-1585) (USDOJ, MMS, 1990), Beaufort Sea Planning Area Lease Sale 144 (Lease OCS-Y-1650) (USDOJ, MMS, 1996) and Beaufort Sea Planning Area Lease Sale 202 (Lease OCS-Y-1886) (USDOJ, MMS, 2003; 2006). In general, the stipulations for the three lease sales are the same. See Appendices C and F for further detail on Lease Sale 124, 144, and 202 stipulations.

1.4.1.3. NEPA

NEPA (42 USC 4321 et seq.) requires Federal agencies to use a systematic, interdisciplinary approach to analyzing the environmental impact of major Federal Actions. This approach ensures integration of natural and social sciences in any planning and decision-making that may have an impact on the environment. In furtherance of these policies, NEPA also requires Federal agencies to prepare a detailed EIS on any major Federal action that may have a significant impact on the environment. An EIS must analyze any adverse environmental effects that cannot be avoided or mitigated, alternatives including the Proposed Action, the relationship between short-term uses and long-term productivity of the environment, and any irreversible and irretrievable commitments of resources. In 1979, the Council on Environmental Quality established uniform procedures for implementing NEPA. These regulations (40 CFR § 1500–1508) provide for the use of the NEPA process to identify and assess the alternatives to proposed actions that avoid and minimize adverse

effects on the human environment. The USDOJ regulations implementing NEPA are at 43 CFR Part 46.

All of BOEM's cooperating Federal agencies—including BSEE, EPA, USACE, NMFS, and USFWS—are also bound by NEPA.

1.4.2. EPA Regulatory Authorities

1.4.2.1. Clean Water Act (CWA)

Section 301(a) of the of the CWA provides that the discharge of pollutants to surface waters of the United States is prohibited except in accordance with a National Pollutant Discharge Elimination System (NPDES) permit. Section 402 of the Clean Water Act establishes the NPDES permit program, which provides the U.S. Environmental Protection Agency (EPA) and the authorized states the authority to control and limit the discharge of pollutants into waters of the United States. HAK has applied for a NPDES permit for the discharge of waste streams associated with the LDPI. The LDPI is located 4.78 nautical miles (8.9 km) offshore in Federal waters of the outer continental shelf; therefore the EPA is the NPDES permitting authority.

Ocean Discharge Criteria Evaluation

In addition, Section 403(c) of the CWA requires that NPDES permits authorizing discharges into the territorial seas, the contiguous zones, and the oceans, including the outer continental shelf, comply with EPA's Ocean Discharge Criteria (40 CFR Part 125, Subpart M). The purpose of the Ocean Discharge Criteria Evaluation (ODCE) is to assess the discharges authorized under the NPDES permit and to evaluate the potential for unreasonable degradation of the marine environment based on the consideration of ten specific criteria.

The ten criteria are specified at 40 CFR Part 125.122, Determination of Unreasonable Degradation of the Marine Environment. The Director shall determine whether a discharge will cause unreasonable degradation of the marine environment based on consideration of:

1. The quantities, composition and potential for bioaccumulation or persistence of the pollutants to be discharged;
2. The potential transport of such pollutants by biological, physical or chemical processes;
3. The composition and vulnerability of the biological communities which may be exposed to such pollutants, including the presence of unique species or communities of species, the presence of species identified as endangered or threatened pursuant to the Endangered Species Act, or the presence of those species critical to the structure or function of the ecosystem, such as those important for the food chain;
4. The importance of the receiving water area to the surrounding biological community, including the presence of spawning sites, nursery/forage areas, migratory pathways, or areas necessary for other functions or critical stages in the life cycle of an organism;
5. The existence of special aquatic sites including, but not limited to marine sanctuaries and refuges, parks, national and historic monuments, national seashores, wilderness areas and coral reefs;
6. The potential impacts on human health through direct and indirect pathways.
7. Existing or potential recreational and commercial fishing, including finfishing and shellfishing;
8. Any applicable requirements of an approved Coastal Zone Management plan;
9. Such other factors relating to the effects of the discharge as may be appropriate;
10. Marine water quality criteria developed pursuant to section 304(a)(1).

Discharges to surface waters of the United States associated with the oil and gas extraction point source category are regulated under 40 CFR Part 435, Subparts A-D, which were promulgated in 1979. Effluent limitation guidelines and new source performance standards for the offshore subcategory of the oil and gas extraction point source category were amended on January 15, 1993 and became effective on March 4, 1993 (40 CFR 435, Subpart A; 58 FR 12454). New oil and gas development and production operations where construction commenced after the effective date of applicable new source performance standards (NSPS) are considered new sources.

40 CFR § 122.2 defines “new source” as follows:

New Source means any building, structure, facility or installation from which there is or may be a “discharge of pollutants,” the construction of which is commenced:

- a. After promulgation of standards of performance under §306 of CWA which are applicable to such source, or
- b. After proposal of standards of performance in accordance with §306 of CWA which are applicable to such source, but only if the standards are promulgated in accordance with §306 within 120 days of their proposal.

The regulations at 40 CFR §122.29(b)(4) define what constitutes “construction” of a new source, stating that:

“Construction has commenced if the owner or operator has:

- (i) Begun, or caused to begin as part of a continuous on-site construction program:
 - (A) Any placement assembly, or installation of facilities or equipment; or
 - (B) Significant site preparation work including clearing, excavation or removal of existing buildings, structures, or facilities which is necessary for placement, assembly, or installation of new source facilities or equipment; or
- (ii) Entered into a binding contractual obligation for the purchase of facilities or equipment intended to be used in its operation with a reasonable time.”

Chapter 2 identifies instances where HAK’s proposal implicates these regulatory programs.

1.4.3. USACE Regulatory Authorities:

The proposed Hilcorp Alaska LLC Liberty Development project requires Federal Action (i.e., a permit) under three U.S. Army Corps of Engineers (USACE) regulatory authorities, in addition to Section 4(f) of OCSLA, which addresses construction of artificial islands on the seabed to the seaward limit of the outer continental shelf. USACE jurisdiction over an artificial island in OCS on “lands” under mineral lease from MMS (now BOEM) is limited to the evaluation of impacts to navigation and national security, 33 CFR 322.5 (f).

1.4.3.1. CWA

Section 404 (b) of the Clean Water Act contains the guidelines for specification of disposal sites for dredged or fill material into waters of the United States (33 USC §§ 1344, 1362) (pipeline in territorial sea, gravel material site in wetlands, VSMs and gravel pads supporting pipeline construction in wetlands). In summary, dredge or fill material shall not be permitted if it violates any applicable State water quality standard; violates any applicable toxic effluent standard; jeopardizes

the continued existence of species listed as threatened or endangered; or violates any marine sanctuary protection requirements.

1.4.3.2. Rivers and Harbors Act (RHA) of 1899

Section 10 of the RHA (commonly referred to as the Rivers and Harbors Act) addresses the construction or modification of structures in navigable waters, or the accomplishment of any other work affecting the course, location, condition, or physical capacity of navigable waters (33 USC §§ 403).

Section 10 of the RHA would also apply to the construction of the pipeline in water on the OCS and in territorial seas.

1.4.3.3. Marine Protection, Research, and Sanctuaries Act of 1972 (as amended)

Section 103 of the Marine Protection, Research, and Sanctuaries Act addresses the transport of dredged material for the purpose of ocean disposal (33 U.S.C § 1413). This would be applicable if the applicant proposes to discharge materials excavated for the construction of the pipeline in the territorial seas, elsewhere in the territorial seas.

1.4.4. NMFS Regulatory Authorities

1.4.4.1. Marine Mammal Protection Act

Under the MMPA (16 USC § 1361 *et seq.*), the taking of marine mammals without a permit or exception is prohibited. The term, “take” under the MMPA, means “to harass, hunt, capture, or kill, or attempt to harass, hunt, capture, or kill any marine mammal.” The MMPA defines “harassment” as “any act of pursuit, torment, or annoyance which (i) has the potential to injure a marine mammal or marine mammal stock in the wild [Level A harassment]; or (ii) has the potential to disturb a marine mammal or marine mammal stock in the wild by causing disruption of behavioral patterns, including, but not limited to, migration, breathing, nursing, breeding, feeding, or sheltering [Level B harassment]”.

In order to obtain an exemption from the MMPA's prohibition on taking marine mammals, a citizen of the U.S. who engages in a specified activity (other than commercial fishing) within a specified geographic region must obtain an Incidental Take Authorization (ITA) under Section 101(a)(5)(A) or (D) of the MMPA. An ITA shall be granted if NMFS finds that the taking of small numbers of marine mammals of a species or stock by such citizen will have a negligible impact on the affected species or stock(s) and will not have an unmitigable adverse impact on the availability of the species or stock(s) for taking for subsistence uses. NMFS or USFWS must base its findings on the best scientific information available (50 CFR Part 216.102(a)). NMFS or USFWS shall also prescribe, where applicable, the permissible methods of taking and other means of affecting the least practicable adverse impact on the species or stock and its habitat (i.e. mitigation, monitoring and reporting of such takings). ITAs may be issued as either (1) regulations and associated Letters of Authorization (LOAs) or (2) Incidental Harassment Authorizations (IHAs). IHAs can be issued only when there is no potential for serious injury and/or mortality or where any such potential can be negated through required mitigation measures. If the analysis of a specific proposal indicates the potential for death or serious injury of marine mammals and that potential cannot be negated through the inclusion of mitigation measures, then NMFS would not issue an IHA and would consider issuing regulations and associated LOA, which allow for “take” of marine mammals by serious injury or mortality.

NMFS has defined “negligible impact” in 50 CFR § 216.103 as “... an impact resulting from the specified activity that cannot be reasonably expected to, and is not reasonably likely to, adversely

affect the species or stock through effects on annual rates of recruitment or survival.” Additionally, NMFS has defined “unmitigable adverse impact” in 50 CFR § 216.103 as:

...an impact resulting from the specified activity: (1) That is likely to reduce the availability of the species to a level insufficient for a harvest to meet subsistence needs by: (i) Causing the marine mammals to abandon or avoid hunting areas; (ii) Directly displacing subsistence users; or (iii) Placing physical barriers between the marine mammals and the subsistence hunters; and (2) That cannot be sufficiently mitigated by other measures to increase the availability of marine mammals to allow subsistence needs to be met.

1.4.4.2. Endangered Species Act

Section 7 (16 USC § 1536) of the ESA states that all Federal agencies shall, in consultation with, and with the assistance of the Secretary of the Interior or Commerce (Secretary), ensure that any action authorized, funded, or carried out by such agency is not likely to jeopardize the continued existence of any endangered species or threatened species or result in the destruction or adverse modification of habitat of such species, which is determined by the Secretary to be critical. Section 9 (16 USC § 1538) of the ESA identifies prohibited acts related to endangered species and prohibits all persons, including all Federal, state and local governments, from taking listed species of fish and wildlife, except as specified under provisions for exemption (16 USC §§1535(g)(2) and 1539). Generally, the USFWS manages land and freshwater species while NMFS manages marine species, including anadromous salmon. However, the USFWS has responsibility for some marine animals such as nesting sea turtles, walrus, polar bears, sea otters, and manatees.

For actions that may result in prohibited “take” of a listed species, Federal agencies must obtain authorization for incidental take through Section 7 of the ESA’s formal consultation process. Under the ESA, “take” means to “harass, harm, pursue, hunt, shoot, wound, kill, trap, capture, or collect, or attempt to engage in any such conduct” to species listed as threatened or endangered in 16 USC § 1532(19). NMFS has further defined harm as follows: “harm” is “...an act which actually kills or injures fish or wildlife. Such an act may include significant habitat modification or degradation which actually kills or injures fish or wildlife by significantly impairing essential behavioral patterns, including, breeding, spawning, rearing, migrating, feeding or sheltering” (50 CFR 222.102). NMFS has not defined the term “harass” under the ESA.

Under Section 7 of the ESA, Federal agencies consult with the USFWS and/or NMFS and submit a consultation package for proposed actions that may affect listed species or critical habitat. If a listed species or critical habitat is likely to be affected by a proposed Federal action, the Federal agency must provide the USFWS and NMFS with an evaluation whether or not the effect on the listed species or critical habitat is likely to be adverse. The USFWS and/or NMFS uses this documentation along with any other available information to determine if a formal consultation or a conference is necessary for actions likely to result in adverse effects to a listed species or its designated critical habitat. If a Federal action is likely to adversely affect endangered or threatened species or designated critical habitat, then USFWS and/or NMFS prepares a Biological Opinion, which makes a determination as to whether the action is likely to jeopardize an endangered or threatened species. If take is anticipated, the USFWS and/or NMFS must also issue an Incidental Take Statement, which includes terms and conditions and reasonable and prudent measures which must be followed.

1.4.4.3. Magnuson-Stevens Fishery Conservation and Management Act

Federal agencies are required to consult with the Secretary of Commerce with respect to any action authorized, funded, or undertaken, or proposed to be authorized, funded, or undertaken, by such

agency that may adversely affect essential fish habitat identified under the Magnuson-Stevens Fishery Conservation and Management Act (MSFCMA).

1.4.5. USFWS Regulatory Authorities

USFWS has authority under ESA and MMPA similar to that described above for NMFS. Generally, the USFWS manages land and freshwater species, and NMFS manages marine species, although there are some exceptions as described above. The USFWS also has authority under the Migratory Bird Treaty Act (MBTA) and the Bald and Golden Eagle Protection Act (BGEPA) to regulate and/or permit, if appropriate, the take or destruction of bird nests, eggs, and nestlings.

1.4.6. PHMSA statutory authority

The Pipeline and Hazardous Materials Safety Administration, or PHMSA, is a U.S. Department of Transportation agency. It was created under the Norman Y. Mineta Research and Special Programs Improvement Act (P.L. 108-426) of 2004 (<https://www.phmsa.dot.gov/about/faq>). PHMSA Regulations pertaining to pipeline safety are specified in 49 CFR Parts 190-199.

1.4.7. SOA regulatory requirements

The State of Alaska has all regulatory, statutory, and permitting authority over waters and lands on the North Slope, (including submerged lands of the Beaufort Sea), other than those that are part of native allotments. The SOA will have permitting authority over several actions associated with the Liberty Development that will occur subsequent to BOEM's approval of Proposed Action or one of the Alternatives analyzed in this DEIS. These actions include, but are not limited to, the construction of onshore ice roads and ice pads, gravel use, and any construction associated with the trench and pipeline in State waters. The State will coordinate the approval of these actions across its agencies and determine whether to approve or deny permits and leases for use of State land. As part of this process, the State will apply additional mitigation measures for the protection of wildlife, air and water quality, and subsistence practices. The State will also participate in reviews of any other necessary plans or authorizations required by the project.

1.4.8. BSEE Regulatory Authorities

BSEE is responsible for regulating and monitoring oil and gas operations on the Federal OCS, promoting safety, and protecting the environment. BSEE Regulations applicable to oil, gas, and sulfur lease operations on the OCS are specified in 30 CFR Part 250. Oil-spill prevention and response rules are specified in 30 CFR Part 254.

The following subsections briefly describe several means through which BOEM and BSEE regulate OCS activities.

1.4.9. BSEE Permitting Responsibilities and Oversight

1.4.9.1. Pipelines

Regulatory authority over pipelines on the OCS and in coastal areas is shared by several Federal agencies, including USDOJ (which includes BOEM and BSEE), the U.S. Department of Transportation (USDOT), the Federal Energy Regulatory Commission (FERC), the U.S. Coast Guard (USCG), and the State of Alaska (SOA) for pipelines shoreward of three nautical miles (5.5 km). SOA standards and regulations would also be applicable when OCS pipelines tie into shore-based facilities, pump stations, or other pipelines when facilities, pump stations, or other pipelines are located in state-owned waters or tidelands within the 3 nm (5.5 km) state boundary.

1.4.9.2. Best Available and Safest Technology Requirements

To ensure all oil and gas exploration, development, production, and decommissioning activities on the OCS are conducted in a safe and pollution-free manner, OCSLA requires that all OCS technologies and operations use the best available and safest technology that the Secretary determines to be economically feasible. These include requirements for:

- State-of-the-art drilling technology
- Production-safety systems
- Well control
- Completion of oil and gas wells
- Oil-spill-response plans (OSRPs)
- Pollution-control equipment
- Specifications for platform/structure designs

1.4.9.3. Technical and Safety Review

The lessee must design, fabricate, install, use, inspect, and maintain all platforms and structures on the OCS to ensure their structural integrity for the safe conduct of operations at specific locations. Applications for platform design and installation are filed with BSEE for review and approval.

Production-safety equipment used on the OCS must be designed, installed, used, maintained, and tested in a manner that ensures the safety and protection of the human, marine, and coastal environments. All tubing installations open to hydrocarbon-bearing zones below the surface must be equipped with safety devices that would shut off the flow from the well in the event of an emergency, unless the well is incapable of flowing. “Incapable of flowing” means that in order to produce hydrocarbons from the well, artificial means would be required using mechanical pumps. All surface production facilities must be designed, installed, and maintained in a manner that provides for efficiency, safety of operations, and protection of the environment.

BSEE will provide for the inspection and oversight of the design and drilling of all wells for the Liberty project. Each well will need to have an approved Application for Permit to Drill (APD) in order for Hilcorp to initiate the drilling of each individual well. BSEE's review will determine whether the well design meets BSEE regulatory requirements as well as what special requirements or conditions that may be necessary while drilling takes place. Once drilling begins, BSEE will conduct appropriate inspections and overall oversight of the operation both onsite as well as thorough review of daily reporting by the operator.

1.4.9.4. Pollution Prevention and Oil-Spill Response

Safety and prevention of pollution, including accidental oil spills, is the primary focus of BSEE OCS operating regulations. Pollution-prevention regulatory requirements for oil, gas, and sulphur operations in the OCS are in 30 CFR 250, Subpart C – Pollution Prevention and Control. These regulations require operators that engage in activities such as exploration, development, production, and transportation of oil and gas to prevent unauthorized discharge of pollutants into offshore waters. Operators shall not create conditions that would pose unreasonable risks to public health, life, property, aquatic life, wildlife, recreation, navigation, commercial fishing, or other uses of the ocean. These regulations further mandate that the operator conduct daily inspections of drilling and production facilities to determine if pollution is occurring. If problems are detected, maintenance or repairs must be made immediately.

In compliance with 30 CFR Part 254, all owners and operators of oil-handling, oil-storage, or oil-transportation facilities located seaward of the coastline must submit an oil spill response plan

(OSRP) to BSEE for approval. Owners or operators of offshore pipelines are required to submit a plan for any pipeline that carries oil, condensate that has been injected into the pipeline, or gas with naturally occurring condensate. Pipelines carrying essentially dry gas do not require a plan. A response plan must be submitted before an owner/operator may use a facility. To continue operations, the facility must be operated in compliance with the approved plan. As a general rule, OSRPs must be updated and re-submitted for BSEE approval every two years. Revisions to a response plan must be submitted to BSEE within 15 days whenever any of the following occur:

- A change occurs that significantly reduces an owner/operator's response capabilities
- A significant change occurs in the worst-case-discharge scenario or in the type of oil being handled, stored, or transported at the facility
- There is a change in the name or capabilities of the oil-spill-removal organizations cited in the plan
- There is a significant change in the appropriate area contingency plans

To ensure plan holder readiness, BSEE will conduct routine inspections of the operator's facilities to ensure that the identified spill response resources are readily available and in the quantities and condition described in the OSRP. BSEE also will conduct government initiated unannounced exercises (GIUE) to test the operator's ability to carry out the provisions of the OSRP. Additional information about oil spill response and exercise requirements can be found in Chapter 4 (section 4.1.1.2).

1.4.9.5. Inspection Program

Under the direction of the BSEE Alaska OCS Region, the BSEE inspection program provides review and inspection of oil and gas operations. BSEE conducts on-site inspections to ensure compliance with lease terms, Notices to Lessees, approved plans, and to ensure that safety and pollution-prevention requirements of regulations are met. These inspections involve items of safety and environmental concern. Further information on the baseline for the inspection of lessee operations and facilities is in the National Office Potential Incident of Noncompliance (PINC) List (USDOI, BSEE, 2013a).

The purpose of the inspection program is to ensure that an oil and gas facility complies with the regulations and that the lessee is conducting operations in accordance with the regulations and approved permits. For this Development and Production Plan, BSEE will develop an inspection strategy commensurate with the scope and nature of the activities described in the plan. BSEE Alaska OCS Region conducts inspections of existing OCS development and production facilities several times a year. BSEE will also conduct on-site inspections of all critical operations, including testing of blowout preventer (BOP) equipment, the running and cementing of casing, and well testing. The BSEE Alaska OCS Region has the authority and will issue an Incident of Non Compliance (INC) (a documented and recordable action) when a violation is found, and may shut-in (deactivate a piece of equipment or shut-down the offshore facility) any activity that is not in compliance with regulations or the approved permit. An activity that has been issued an INC or a shut-in may not restart until the BSEE Alaska OCS Region has inspected and confirmed that the non-compliance or the shut-in has been properly corrected. More information can be found at:

<https://www.bsee.gov/what-we-do/offshore-regulatory-programs/offshore-safety-improvement/potential-incident-of-noncompliance-pinc>.

1.4.9.6. Structure Removal and Site Clearance

Lessees/operators have one year from the time a lease is terminated to plug and abandon all wells and remove all structures from a leased area (30 CFR 250.1700–250.1754). BSEE requires lessees to submit a procedural plan for site-clearance verification. Lessees must ensure all objects related to

their activities are removed following termination of their lease. All surface equipment to a depth of 15 feet (4.6 m) below mudline will be removed.

1.4.9.7. Training Requirements for Offshore Personnel

Proper training is important for ensuring that OCS oil and gas operations are carried out in a manner that emphasizes operational safety and minimizes the risk of environmental damage. Industry offshore personnel are required to have well control and production safety training, though training is job dependent and not everyone on the platform may have training in all aspects of the work conducted at the facility (30 CFR 250.1500-1510).

1.4.9.8. Safety and Environmental Management Systems (SEMS)

BSEE requires companies to develop, implement, and maintain a Safety and Environmental Management System (SEMS) program to promote safety and environmental protection. This program identifies, addresses, and manages safety, environmental hazards, and impacts during the design, construction, start up and operations to be conducted on the Outer Continental Shelf. The program also ensures that all personnel involved with the program receive appropriate training to perform their assigned duties. See 30 CFR 250 subpart S for more information.

Proposed Action and Alternatives

This page intentionally left blank

Table of Contents

Chapter 2. Proposed Action and Alternatives	2-1
2.1. Proposed Action.....	2-1
2.1.1. Winter & Summer Access	2-4
2.1.2. Gravel Mine Site Development	2-9
2.1.3. Liberty Development and Production Island Construction.....	2-12
2.1.4. Pipeline Construction.....	2-13
2.1.5. Facilities Construction	2-18
2.1.6. Drilling Operations	2-19
2.1.7. Production Operations	2-20
2.1.8. Decommissioning	2-21
2.1.9. EPA Permitting.....	2-23
2.1.10. USACE Permitting	2-27
2.1.11. NMFS Permitting.....	2-28
2.2. Alternatives.....	2-29
2.2.1. Alternatives Selection Process.....	2-29
2.2.2. Alternative 1 (Proposed Action).....	2-31
2.2.3. Alternative 2 (No Action).....	2-32
2.2.4. Alternative 3 (Alternate LDPI locations).....	2-32
2.2.5. Alternative 4 (Alternate Processing Locations).....	2-38
2.2.6. Alternative 5 (Alternate Gravel Sources)	2-48
2.2.7. Alternative Comparison Tables	2-53
2.3. Alternatives Considered but Not Carried Forward for Further Analysis.....	2-58
2.3.1. Ultra-Extended Reach Drilling (uERD).....	2-58
2.3.2. Horizontally Directional Drilling (HDD) Pipeline Landfall.....	2-59
2.3.3. OCS Gravel Mining and Summer LDPI Construction	2-61
2.4. Mitigation.....	2-61
2.4.1. Proposed Mitigation Measure.....	2-61

List of Figures

Figure 2-1. Proposed Action Area	2-3
Figure 2.1.1-1 Proposed Ice Road Routes	2-4
Figure 2.1.1-2. Marine Traffic Route, West Dock and Endicott SDI to LDPI	2-7
Figure 2.1.1-3. Marine Traffic Route, Dutch Harbor to LDPI.....	2-8
Figure 2.1.2-1. Proposed Action Generalized Mine Site View (for analysis purposes).....	2-11
Figure 2.1.2-2. Proposed Action Mine Site Cross Section.	2-12
Figure 2.1.3-1. Liberty Development and Production Island (LDPI) (Preliminary)	2-12
Figure 2.1.3-2. Conceptual 3-D Rendering of Proposed LDPI.....	2-13
Figure 2.1.4-1. Liberty Pipeline Schematic	2-14
Figure 2.1.4-2. Badami Ice Road Crossing Pad, Plan View	2-15
Figure 2.1.4-3. Badami Ice Road Crossing Pad, Section View	2-15
Figure 2.1.4-4. Onshore Tie-In Pad, Plan View	2-16
Figure 2.1.4-5. Onshore Tie-In Pad, Section View.....	2-16
Figure 2.1.4-6. Pipeline Landfall Schematic, Section View.....	2-17

Figure 2.1.8-1.	Proposed Mine Site Reclamation Section View	2-21
Figure 2.2.2-1.	Proposed Action	2-31
Figure 2.2.4-1.	Alternative 3A: LDPI Moved Approximately 1 Mile East.....	2-33
Figure 2.2.4-2.	Alternative 3B: LDPI Moved Approximately 1.5 Miles to the Southwest.....	2-35
Figure 2.2.5-1.	Alternative 4A: Endicott SDI Processing + Alternate Pipeline Route.	2-39
Figure 2.2.5-2.	Alternative 4B: Onshore Processing.....	2-44
Figure 2.2.6-1	Alternative 5: Alternate Mine Site Locations, Overview	2-49
Figure 2.2.6-2.	Alternative 5: Alternate Mine Site Locations, Detail	2-50
Figure 2.3.2-1.	Schematic depicting a possible HDD alternative for the Liberty Project.....	2-60

List of Tables

Table 2-1.	Liberty Timeline	2-1
Table 2.1.1-1.	Projected Surface Vehicle Traffic	2-6
Table 2.1.1-2.	Marine Traffic and Vessel Types	2-9
Table 2.1.1-3.	Projected Helicopter Traffic.*	2-9
Table 2.2.7-1.	Alternatives Comparison Table, Onshore Activities	2-53
Table 2.2.7-2.	Alternatives Comparison Table, Offshore Activities.	2-54
Table 2.2.7-3.	Alternative Comparison Table, Operations and Decommissioning	2-55
Table 2.2.7-4.	Alternatives Comparison Table, Permitting Summaries.	2-56
Table 2.2.7-5.	Alternatives Comparison Table, Key Changes from the Proposed Action	2-57

Chapter 2. PROPOSED ACTION AND ALTERNATIVES

This chapter describes:

- Hilcorp Alaska's (HAK's) Revised Liberty Development and Production Plan (Liberty DPP, or DPP), which represents the Proposed Action analyzed in the DEIS.
- Alternatives developed during the scoping process that are analyzed in this DEIS
- Alternatives that were considered but not analyzed in detail.
- Proposed mitigation.

Tables 2.2.7-1 - 2.2.7-5 compare aspects of the Proposed Action and the Alternatives described later in this chapter. As stated in Chapter 1, this DEIS contains a greater level of detail about the regulatory and permitting actions of the Cooperating Agencies (EPA, USACE, NMFS, BSEE) that intend to adopt the Final EIS. Throughout this DEIS, the Proposed Action refers to the DPP as submitted by HAK. The Cooperating Agencies that are adopting the Final EIS may only require analysis of certain aspects of the Proposed Action, but not the full action itself, in order to issue a permit.

2.1. Proposed Action

HAK proposes to construct the Liberty Drilling and Production Island (LDPI) to recover petroleum reserves from three Federal leases (OCS-Y-1650, OCS-Y-1585, and OCS-Y-1886) in Foggy Island Bay in the Beaufort Sea, northeast of the Prudhoe Bay Unit and east of the Duck Island Unit.

The schedule for the Liberty Project is described below. Multiple activities occur concurrently and would use the same access vehicles/vessel.

Table 2-1. Liberty Timeline.

CONSTRUCTION OPERATIONS	
Activity	Timing
Summer & Winter Access	Year 1 - Year 3
Annual Ice Road (#1)	Year 1 - Year 3, January – mid-May
Support Ice Roads (#2 - #4)	Year 1 – Year 4, December – mid-April
Hovercraft & Amphibious Vehicles	Year 2 - Year 4, April - June and September - December
Sea-going Barges	Year 2 - Year 4, June - November
Small Marine Vessels	Year 2 - Year 4, June - November
Gravel Mine Site Development & Island Construction	Year 2, February – September
	Year 3, February – September ¹
Pile Driving	Year 2, June - August
Facilities Construction	Year 2, August - Year 4, May
Pipeline Construction	Year 3, January - May
DRILLING OPERATIONS	
Activity	Timing
Summer & Winter Access	Year 2 - Year 4
Annual Ice Road (#1)	Year 2 - Year 4, January – mid-May, <i>additional lanes</i>
Hovercraft & Amphibious Vehicles	Year 2 - Year 4, April - June and September - December
Sea-going Barges	Year 2 - Year 4, June - November
Small Marine Vessels	Year 2 - Year 4, June - November
Drilling Operations	Year 2 - Year 4

DRILLING OPERATIONS Continued	
Activity	Timing
Drilling Operations	Year 2 - Year 4
Rig Mobilization	Year 2, July - August
Rig Support Mobilization	Year 2, August – September
Rig Installation, Commissioning	Year 2, August – November
Drill L-01 Waste Disposal Well ²	Year 2, December – Year 3, January
Drill L-03 Gas Injector Well	Year 3, January – March
Drill L-04 Producer Well	Year 3, March – May
DRILLING OPERATIONS	
Activity	Timing
Drill Water or Gas Injector Well	Year 3, May –June ³ ; July - August
Drill Producer Well	Year 3, June – July ³ ; August-September
Remaining Drill Schedule TBD	Year 3- Year 4
First Oil/Commissioning	Year 3, December - Year 4, May
PRODUCTION OPERATIONS	
Activity	Timing
Production Operations	Year 3 - Year 23
Summer & Winter Access	Year 5 - Year 23
Annual Ice Road (#1)	Year 5 - Year 23, January – mid-May
Hovercraft & Amphibious Vehicles	Year 5 - Year 23, April - June and September - December
Sea-going Barges	Year 5 - Year 23, June - November, <i>about once every 5 years</i> ⁴
Small Marine Vessels	Year 5 - Year 23, June - November
DECOMMISSIONING	
Activity	Timing
Summer & Winter Access	Year 24 - Year 25
Annual Ice Road (#1)	Year 24 - Year 25, January – mid-May
Support Ice Roads (#2, #4)	Year 24 – Year 25, December – mid-April
Hovercraft & Amphibious Vehicles	Year 24 – Year 25, April - June and September - December
Sea-going Barges	Year 24 – Year 25, June - November
Small Marine Vessels	Year 24 – Year 25, June - November
Island, Pipeline and Facilities Removal	Year 24 - Year 25
Pile Removal	Year 25, June - August

Notes: ¹: LDPI construction may occur over two winter seasons, as ice conditions allow.
²: Non-reservoir well.
³: Denotes a seasonal drilling restriction due to spill-response capabilities or subsistence hunting.
⁴ Italics denote additional information

Details on the proposed LDPI:

- Located approximately 5 miles (8 kilometers (km)) north of the Kadleroshilik River and 7.3 miles (11.7 km) southeast of the existing Endicott Satellite Drilling Island (SDI)
- Built in approximately 19 feet (ft) (5.8 meters (m)) of water with the elevation of the top of the LDPI +15 ft (4.6 m) above Mean Lower Low Water (MLLW) level
- Work surface of approximately 9.3 acres (ac) or 3.8 hectares (ha)
- Seabed footprint would be approximately 24 ac (9.7 ha)

- Design life and associated infrastructure is approximately 25 years, as shown in Table 2-1.

The proposed LDPI location is shown in Figure 2-1.

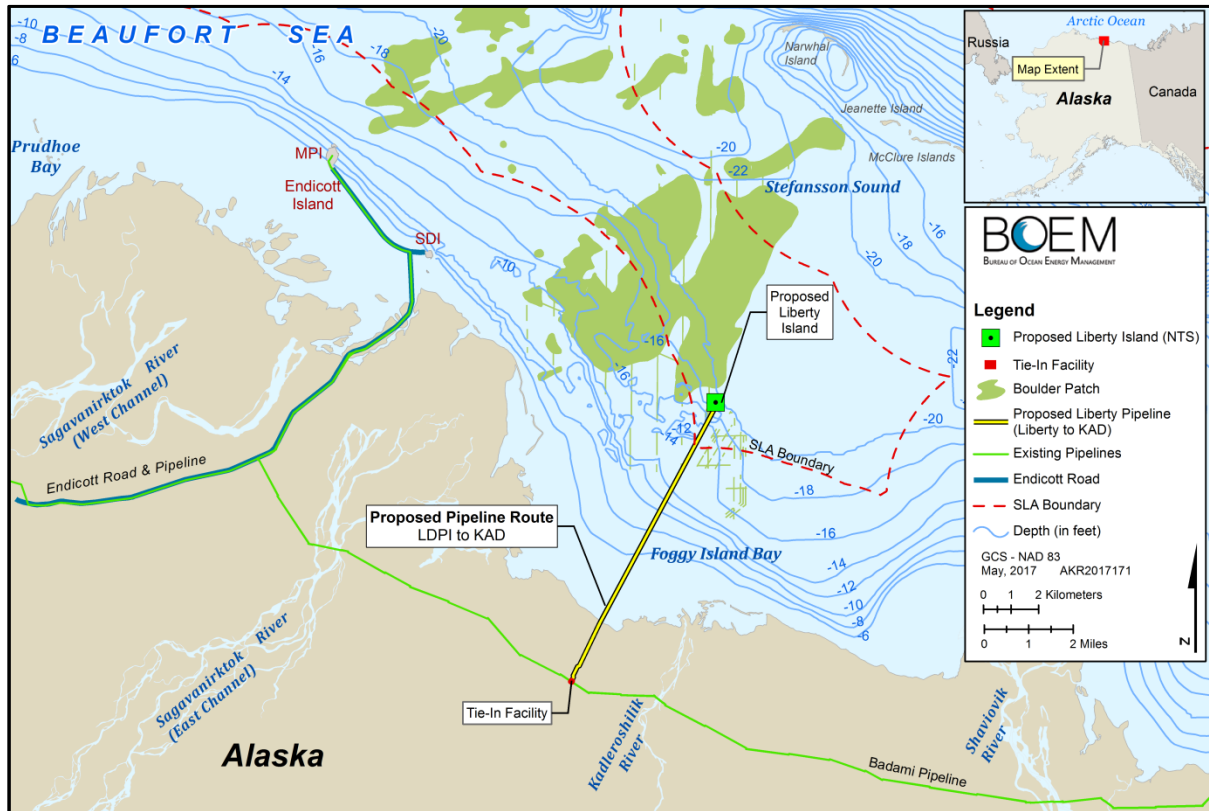

Figure 2-1. Proposed Action Area.

Associated onshore facilities and activities to support the project would include construction and development of:

- Ice roads
- Gravel pads to support the pipeline tie-in location and Badami ice road crossing
- Ice pads
- A hovercraft shelter and small boat dock
- A gravel mine site west of the Kadleroshilik River

Existing North Slope infrastructure, including the Deadhorse Airport, West Dock, the Trans-Alaska Pipeline System and the Dalton Highway, would be used to support this project.

Regulatory oversight information for various Federal and State entities is described in Chapter 1.

General project information is available in Section 2 of the DPP. Additional information on the project schedule is available in Section 3.2, Project Execution Phase.

Both the onshore and offshore portions of this project have been archaeologically surveyed with no significant findings. Further information is available in Section 3.3.6 Archaeological Resources.

2.1.1. Winter & Summer Access

Ice Road Construction

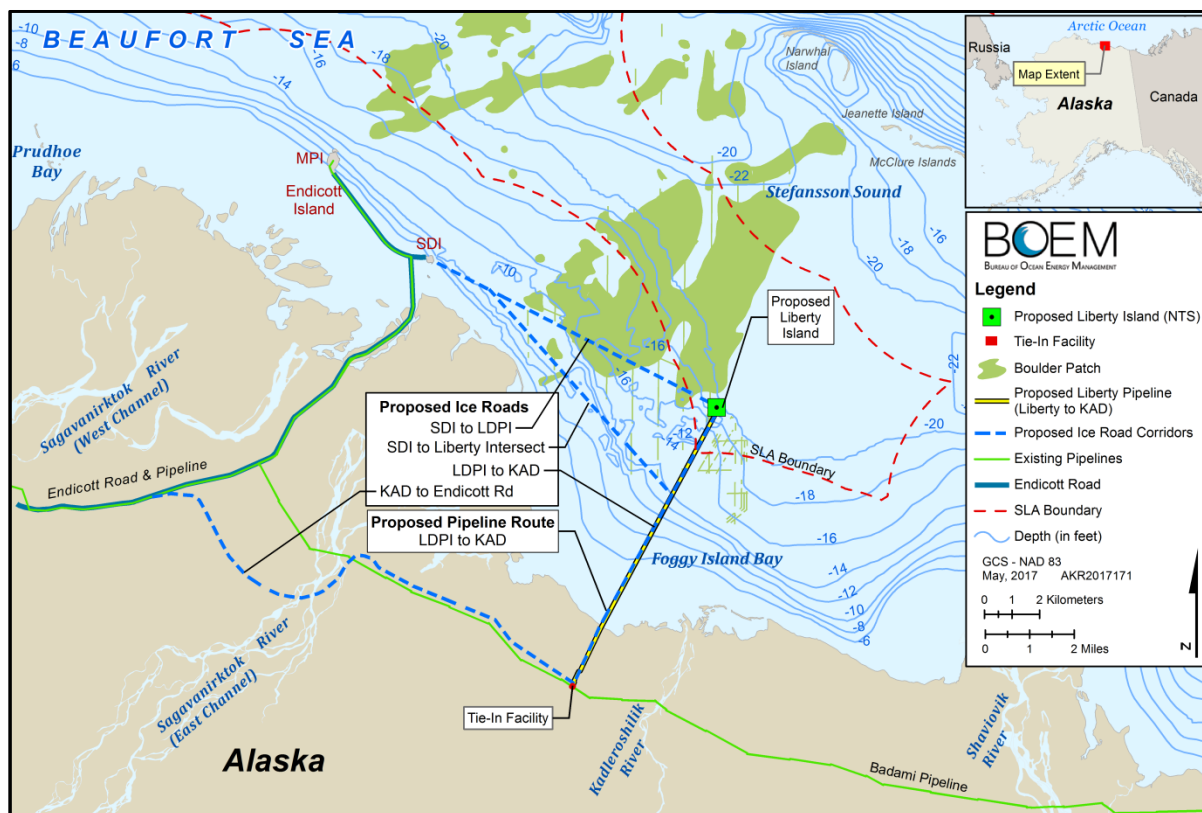

Figure 2.1.1-1 Proposed Ice Road Routes

HAK proposes to construct four ice roads to support construction operations (Figure 2.1.1-1):

- Endicott SDI to LDPI
- LDPI to the mine site (continuing to the Badami ice road juncture)
- Midpoint access road
- Badami ice road

The State of Alaska, Department of Natural Resources (ADNR) regulates many aspects of winter travel on the Alaska North Slope (ANS). The Division of Mining, Land and Water is responsible for permitting ice road construction and winter travel without ice roads while the Water Resources Office (DNR WRO) regulates temporary water withdrawal (used for onshore ice road construction) from rehabilitated and existing mine sites and tundra ponds.

HAK currently holds a general permit (# LAS 29963) for ice road and ice pad construction on all State owned lands on the ANS bordered by the Canning River to the east, the Colville River to the west and the Brooks Range to the south using State approved vehicles. This permit requires an annual application showing the location, an anticipated schedule of operations and a list of vehicles/equipment used for travel, among several other items. BOEM has assumed for this DEIS that ice road and ice pads would be constructed under this, or a similar permit, regulated by ADNR.

HAK does not anticipate mechanized on-ice travel without the use of ice roads. For the purpose of this analysis, BOEM assumes that there would be no travel across shorefast ice or tundra without the use of ice roads as part of the Proposed Action.

Ice road #1 (annual ice road between Endicott SDI and LDPI):

- Approximately 7 miles (11.11 km) long
- Approximately 120 ft (37 m) wide with a driving lane width of 40 ft (12.2 m)
- Between 70 inches (1.8 m) and 96 inches (2.4 m) thick
- Would cover approximately 160 ac (64.7 ha) of sea ice in total

Ice road #2 (years 2-3, connecting the LDPI to the mine site):

- Approximately 6 miles (9.7 km) long
- Approximately 50 ft (15 m) wide
- Approximately 6-inches (15 cm) thick onshore

Ice road #3 (midpoint access road built on grounded sea ice)

- Approximately 4 miles long
- Approximately 40 ft wide
- Between 70 inches and 96 inches (8 ft) thick

Ice road #4 (Badami ice road):

- Approximately 9 miles (14.5 km) long
- Approximately 30 feet (9.1 m) wide
- Approximately 6 inches (15 cm) thick

Typically, ice roads constructed on the tundra to access water sources would be approximately 6 inches (15 cm) thick with a traveled surface width of approximately 30 ft (9 m). The actual width and depth of the ice in a given year would be based upon that year's activities and the required loads.

Ice roads (#1, #2 and #4) would be constructed in Year 1 and Year 2 to support transportation from existing North Slope roads to the proposed gravel mine site, and from the mine site to the proposed LDPI location in the Beaufort Sea.

Ice roads (#1 – 4) would be reconstructed in Year 2 and Year 3 to support the pipeline installation, including the offshore section from the shore crossing to LDPI, and the onshore portion that includes the tie in to the Badami pipeline. Both sections of the pipeline would require access via an ice road system for construction.

Additional ice roads (along #1 corridor) from Endicott SDI would be constructed in Years 2 through 5 to allow additional materials and equipment to be mobilized to support LDPI, pipeline, and facility construction activities.

An ice road (#1) connecting Endicott SDI to the LDPI is expected to be constructed annually to support production operations in Years 5-23 for LDPI resupply and personnel transport.

According to the DPP, a team can construct approximately 1 mile of ice road per day. HAK proposes to construct approximately 34 miles (55 km) of ice roads during the construction phase. Ice roads are best constructed when weather is -20° to -30°F (-29° to -34°C, but temperatures below 0°F (-17.7°C) are considered adequate for ice road construction. Ice road construction can typically be initiated in mid to late December, and ice roads can be maintained until mid-May of the following year. When use of a road has ended, the road would be barricaded by a snow berm and allowed to melt naturally in spring.

HAK would use seawater to construct the offshore ice roads.

Sea Ice Road Construction Steps:

- Clear away snow
- Smooth/grade ice surface (rubble ice would be incorporated into or moved outside the expected road surface approximately 200 ft either side of the center line)
- Pump seawater from holes drilled through floating ice
- Flood the ice road. Flooding techniques are dependent on the conditions of the sea ice: grounded ice typically requires limited flooding with fresh water to either cap or repair cracks. Floating ice requires flooding with seawater until a desired thickness is achieved. Thickness of floating ice would be determined by the required strength and integrity of the ice. After the desired thickness is achieved, floating ice areas may then be flooded with fresh water to either cap or repair cracks—a technique that minimizes the usage of fresh water while obtaining the desired thickness of the ice road.

Roads across the tundra are constructed after the soil is frozen and there is adequate snow cover. Ice rubble is knocked down into the planned road path and rough areas are flooded only as needed to allow tracked vehicles and rolligons to travel the road.

More information on ice roads is available in the Liberty DPP, Section 5.1.2 Ice roads, Section 5.1.5 Surface Transportation, and Section 5.2 Access by Project Phase.

Ice Pad Construction

In addition to the ice road system, three ice pads are also proposed. These would be used to support LDPI, pipeline, and facilities construction, including the pipe stringing and two stockpile/disposal areas needed for pipeline construction. During production well drilling operations, an additional storage area of approximately 350 ft by 700 ft would be built on the sea ice on the west side of the island. This site would be used to store tubulars and other clean materials.

More information on ice pads is available in the DPP, Section 10.1 Ice Roads.

Winter Transportation Estimates

HAK would utilize ground vehicles (heavy duty diesel trucks, light duty diesel pickup trucks, trimmers, tractors, loaders, and excavators, etc.) during periods when ice roads can be constructed and used. Surface transportation to the onshore pipeline in winter would be via ice roads and in summer by approved tundra travel vehicles (Table 2.1.1-1). The largest volume of traffic is anticipated to occur during gravel hauls to create the LDPI.

Table 2.1.1-1. Projected Surface Vehicle Traffic

Estimated Fuel Capacity (Gallons)	Island, Pipeline & Facilities Construction [Years 2 – 4] (Trips)	Drilling & Production Operations [Years 3 – 4] (Trips)	Production Operations [Years 4 – 23] (Trips)	Decommissioning [~Years 20-25]
80	21,000 per season	400 per season	100 per season	21,000 per season

Summer Transportation Estimates

During the open-water season (generally June – November), HAK would use barges, hovercraft or small vessels to transport equipment, personnel and supplies to the LDPI from West Dock or Endicott SDI. Large barges and tugs would be used to transport large equipment (i.e. drilling rig) and supplies, transiting through Dutch Harbor to LDPI, or, alternatively, from West Dock or Endicott SDI to LDPI. Most construction materials would be transported via barge from West Dock or Endicott SDI to LDPI. Hovercraft would transport personnel and small loads during shoulder seasons when ice roads and open-water vessel support are not available. Amphibious vehicles would be used for emergency evacuation.

The marine transit route from West Dock to LDPI is about 25 miles (; from Endicott SDI to LDPI is about 7.7 miles.

Table 2.1.1-2 provides descriptions of the types of offshore vessels that are anticipated to be used within 25 miles (40 km) of the LDPI during construction, drilling and production operations. Figures 2.1.1-2 and 2.1.1-3 illustrate the general marine traffic routes described in this section.

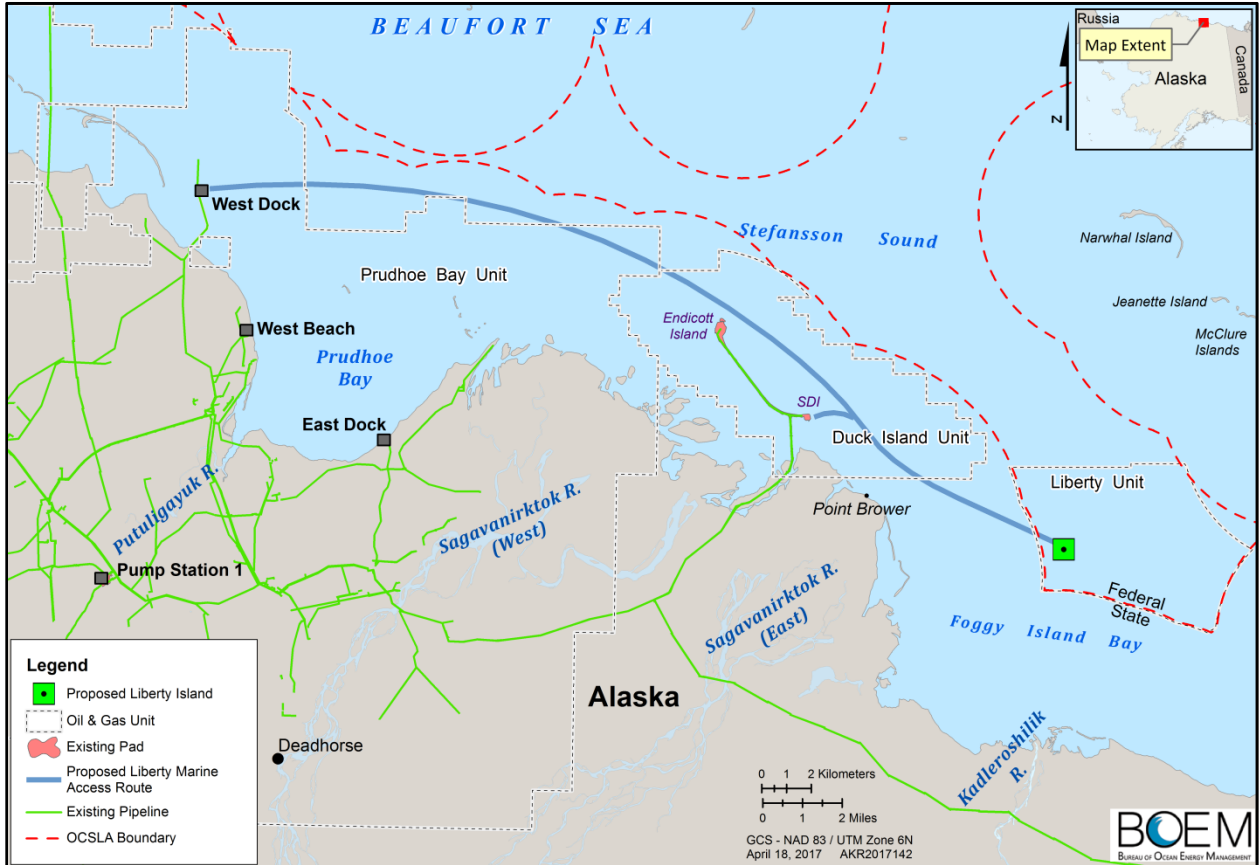

Figure 2.1.1-2. Marine Traffic Route, West Dock and Endicott SDI to LDPI.



Figure 2.1.1-3. Marine Traffic Route, Dutch Harbor to LDPI

Table 2.1.1-2. Marine Traffic and Vessel Types

Mode	Number of Vessels	Estimated Fuel Capacity (Gallons)	Island, Pipeline & Facilities Construction [Years 2 – 4] (Trips)	Drilling & Production Operations [Years 3 – 4] (Trips)	Production Operations [Years 4 – 23] (Trips)
Seagoing Barge	1 to 2	Not Applicable	2-5/year	1/ 5 years	1/ 5 years
Ocean Class Tug	1 to 2	252,000	2-5/year	1/ 5 years	1/ 5 years
Coastal Barge	1 to 2	700	3/day	20/year	10/year
Assist Tug	1 to 2	22,000	3/day	20/year	10/year
Crew Boat	1 to 2	300	12/day	2/day	90/year
Bathymetry Vessel (Ancillary Activity)	1	300	1 survey	1/year	1/year
Hovercraft	1	250	3/day	2/day	2/day
Amphibious Vehicles	2	--0	--0	As needed	As needed

HAK plans to have year-round helicopter access to the LDPI when weather conditions and visibility permit. Helicopter use is also planned for pipeline surveillance, personnel transport, re-supply during the broken ice seasons, and access for maintenance and inspection of the onshore pipeline system (Table 2.1.1-3).

Table 2.1.1-3. Projected Helicopter Traffic.*

Estimated Fuel Capacity (Gallons)	Pre-Construction Data Gathering	Island, Pipeline & Facilities Construction [Years 2 – 4] (Trips)	Drilling & Production Operations [Years 3 – 4] (Trips)	Production Operations [Years 4 – 23] (Trips)
400	1/week	1-2/day	2/day	1-2/day

Note: *Fixed-wing aircraft use, while not part of the Proposed Action, may occur over the life of the project for the purpose of pipeline monitoring, marine mammal monitoring, or in the event of an oil spill. Impacts of fixed wing aircraft to marine and terrestrial mammals are discussed in Sections 4.3.4-4.3.5.

2.1.2. Gravel Mine Site Development

The description of the mine site and gravel use is provided herein as baseline general assumptions for analysis. BOEM assumes for this DEIS that the mine site would be regulated by the U.S. Army Corps of Engineers (USACE) (as described in Chapter 1) under an Individual Permit. Details of the USACE's possible regulatory actions are available for each alternative in sections titled "USACE Permitting".

The proposed gravel mine site (West Kadleroshilik Site #1) is located approximately 6.2 miles (10 km) south of the proposed LDPI and 1.5 miles (2.4 km) west of the Kadleroshilik River, as shown on Figure 2.1.2-1. Transport of gravel from the mine site to the proposed LDPI would require approximately 14 trucks working for 76 days, using roughly 380,000 gallons (1.44M liters) of fuel.

Mine site development includes removal of snow and ice, removal and stockpiling of unusable overburden material, blasting, pit excavation, gravel hauling, and backfill of unusable material into the pit. Once the mine is no longer needed, the pit would be flooded and reclaimed.

Details about the proposed mine site:

- The area of ground excavated would be about 25 ac (10.1 ha).
- There would be an ice pad of approximately 250 ft (76 m) surrounding the pit. The ground in this boundary area would not be disturbed; this ice pad boundary area brings the total mine site area to 49 ac (19.8 ha).
- The mine site would be approximately 46 - 60 ft (14-18 m) deep.
- The first lift (mining cycle) would remove about 20 ft (6 m) of overburden, although this may be variable once excavation work begins. The second and third lifts would remove material at 20 ft (6 m) depth intervals.

The gravel source is high quality, exhibiting fines content (percent passing the #200 sieve) of less than 10% (mean value of about 4%). The percent of gravel in each core ranges from 15 to 55%, with a mean value of about 35%. Diagrams are included below to illustrate the mine site plan view (Figure 2.1.2-1) and mine site cross-section (Figure 2.1.2-2); reclamation figures for the mine site are in Section 2.1.8 Decommissioning.

Up to 1,500,000 cubic yards (cy) of gravel could be excavated to support construction activities on the LDPI. This includes:

- Less than 950,000 cy for the LDPI
- About 3,500 cy for the Badami tie in pad
- About 1,500 cy for the Badami ice road crossing
- About 5,000 cy for the pipeline landfall.

The remaining yardage would be used for pipeline select backfill, maintenance, and contingency needs. As stated above, ice roads and ice pads would be constructed to support mining and gravel haul during construction.

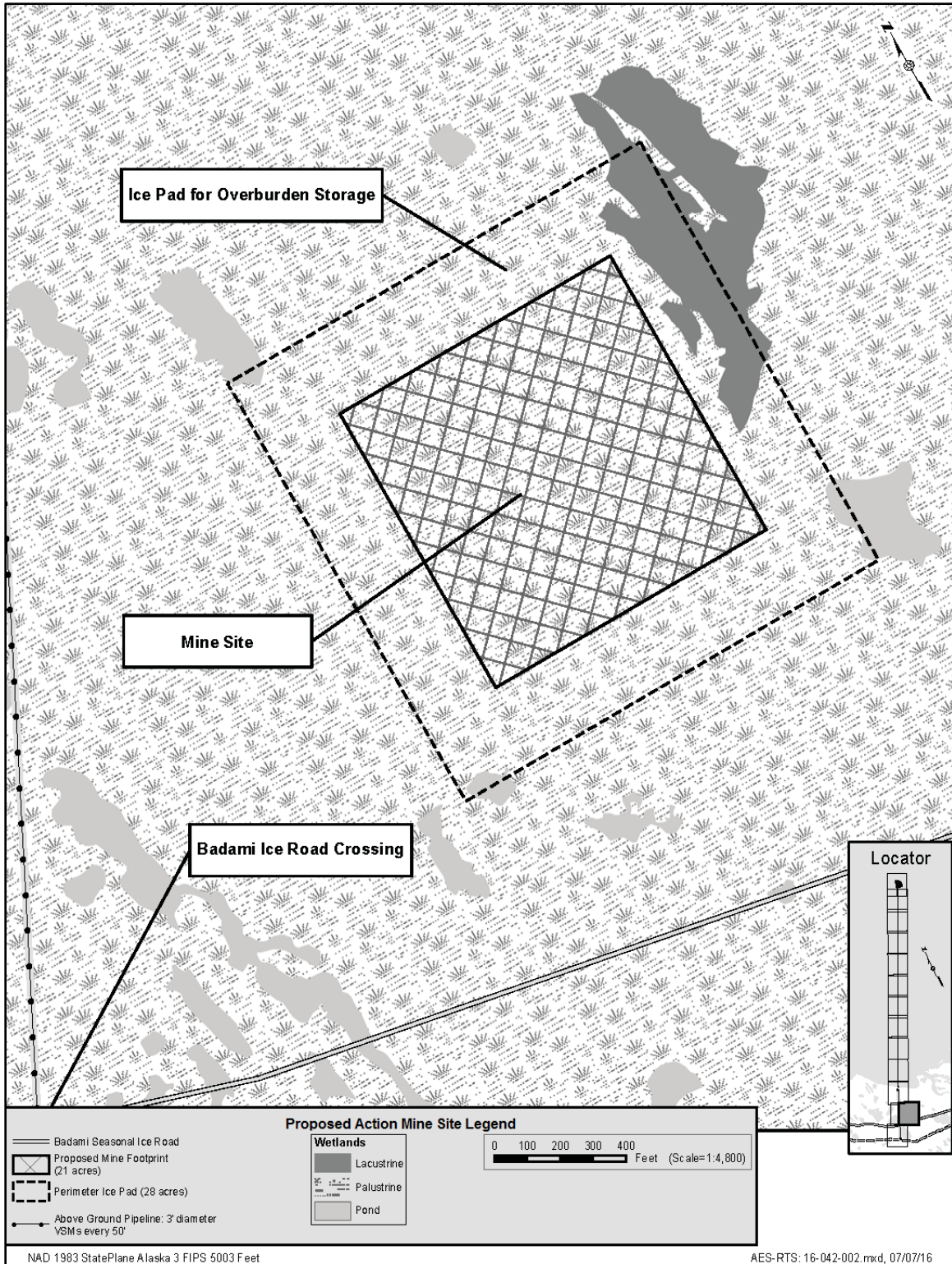

Figure 2.1.2-1. Proposed Action Generalized Mine Site View (for analysis purposes).

HAK proposes a single year mining program, with a second year contingency option in case of poor offshore ice conditions that could restrict gravel transport to the LDPI site. If the second winter season is necessary, HAK would store the overburden material within the mine site.

More information on ice pads is available in the DPP, Section 3.2.3 Mine Site Development and Section 10.3 Gravel Sources.

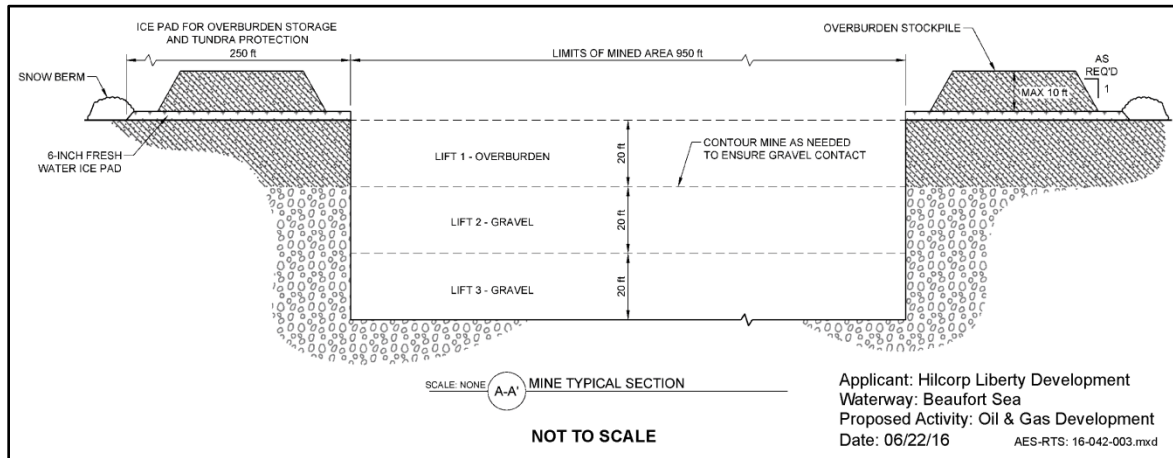

Figure 2.1.2-2. Proposed Action Mine Site Cross Section.

2.1.3. Liberty Development and Production Island Construction

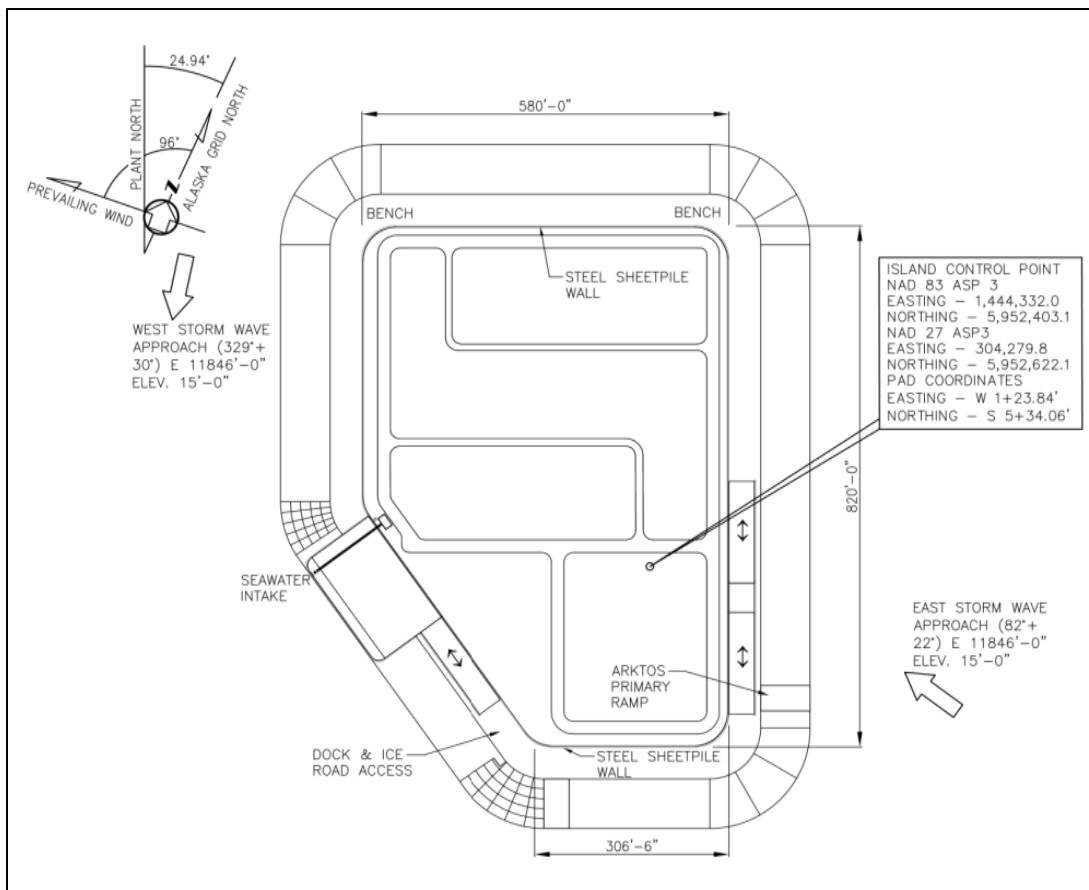

Figure 2.1.3-1. Liberty Development and Production Island (LDPI) (Preliminary)

The LDPI (and pipeline) would be constructed during the winter seasons of the first three years of the project. Island construction would commence as soon as the ice road from the gravel mine site to the

LDPI construction site is completed. Figures 2-1, 2.1.3-1 and 2.1.3-2 show the location, preliminary island schematic and a conceptual rendering of the island.

Gravel hauling over the ice road to the LDPI construction site would continue for 50 to 80 days and conclude in mid-April, or earlier if the road conditions dictate. Once gravel haul is complete and before breakup, slope protection installation would begin, continuing into the 3rd quarter of Year 2. The driven sheet pile wall around much of the LDPI perimeter would be installed before the end of the 3rd quarter of Year 2. Well conductors (conductor pipe that is driven into the earth in the shallow section of wells through unconsolidated sediment, providing stability for the initiation of the deeper drilling) and some foundation piles would be driven during this same timeframe.

A detailed description of pile driving is discussed in HAK's acoustic model for this project (COMPANY, 2017); mitigation measures for this activity are discussed in Appendix C.



Figure 2.1.3-2. Conceptual 3-D Rendering of Proposed LDPI.

The LDPI slopes would be protected from erosion due to winds and waves by a combination of interlocking concrete mats and sheet piling, and potentially gravel bags or large boulders as a secondary measure. Comparatively, on Northstar Island which is outside the protection of the barrier islands, HAK replaces about 25 of 18,000 (0.0014%) concrete mats annually, and about 200 of 18,000 (0.011 %) every 5 years on a routine island repair cycle.

The work surface of the proposed LDPI would be about 9.3 ac (3.8 ha); the seabed footprint would be roughly 24 ac (9.7 ha). Construction of the proposed LDPI would require less than 950,000 cy of gravel. The design life of the LDPI and associated infrastructure is approximately 25 years.

2.1.4. Pipeline Construction

HAK proposes a pipe-in-pipe subsea pipeline, (PIP) consisting of a 12-inch (30.5 cm) diameter inner pipe and 16-inch (40.6 cm) diameter outer pipe. The production pipeline would be bundled with a nominal 4-inch (10 cm) coiled utility line, along with an armored fiber optic cable. The utility line would be installed as a contingency for possible future use as a fuel gas delivery line or to allow for a circulation loop with the 12-inch (30.5 cm) export line for upset conditions (Figure 2.1.4-1).

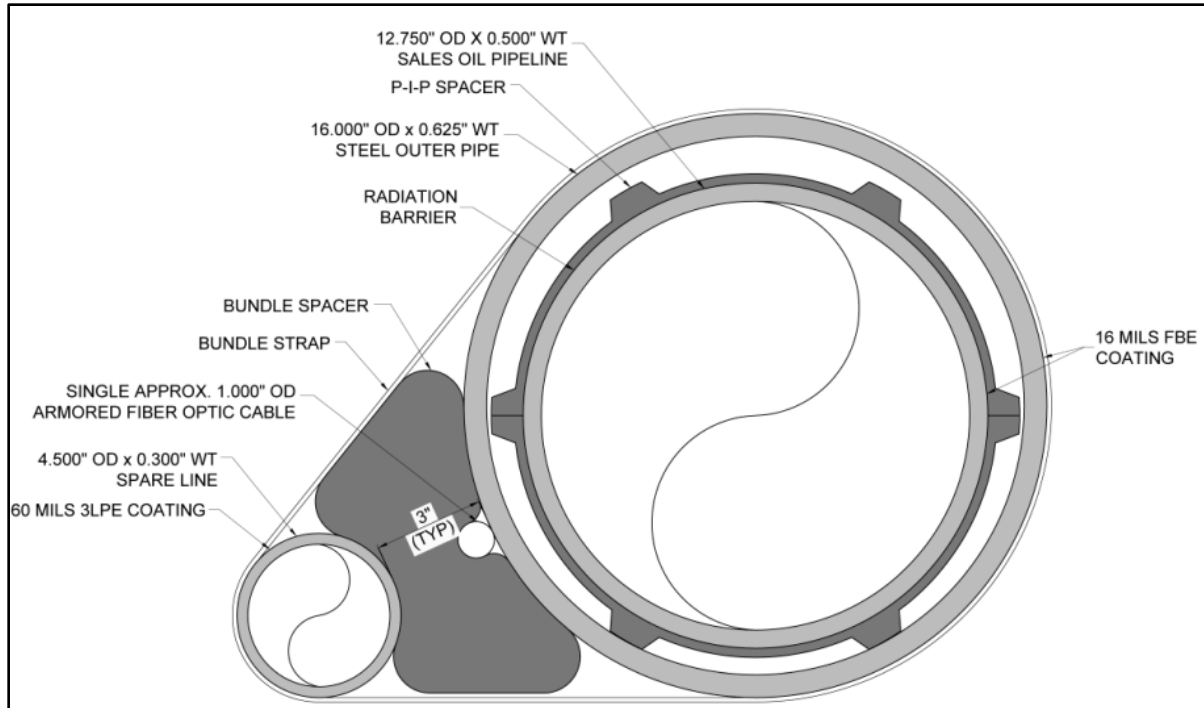

Figure 2.1.4-1. Liberty Pipeline Schematic

Pipeline construction is planned for the winter following LDPI construction, which HAK anticipates to be the first two quarters of Year 3. The offshore and onshore pipeline segments would be installed within the same time frame, with two separate construction spreads of equipment and manpower.

The pipeline would extend from the LDPI to a tie-in with the Badami Pipeline system. Two onshore gravel pads would be constructed in close proximity starting at the tie-in. The Badami ice road crossing (over the Liberty pipeline) pad would require up to 3,500 cy of gravel and would have a footprint of approximately 0.15 ac (0.06 ha). The pipeline would be buried in the gravel pad at this crossing point. A section and plan view of the pad is shown in Figures 2.1.4-2 and 2.1.4-3.

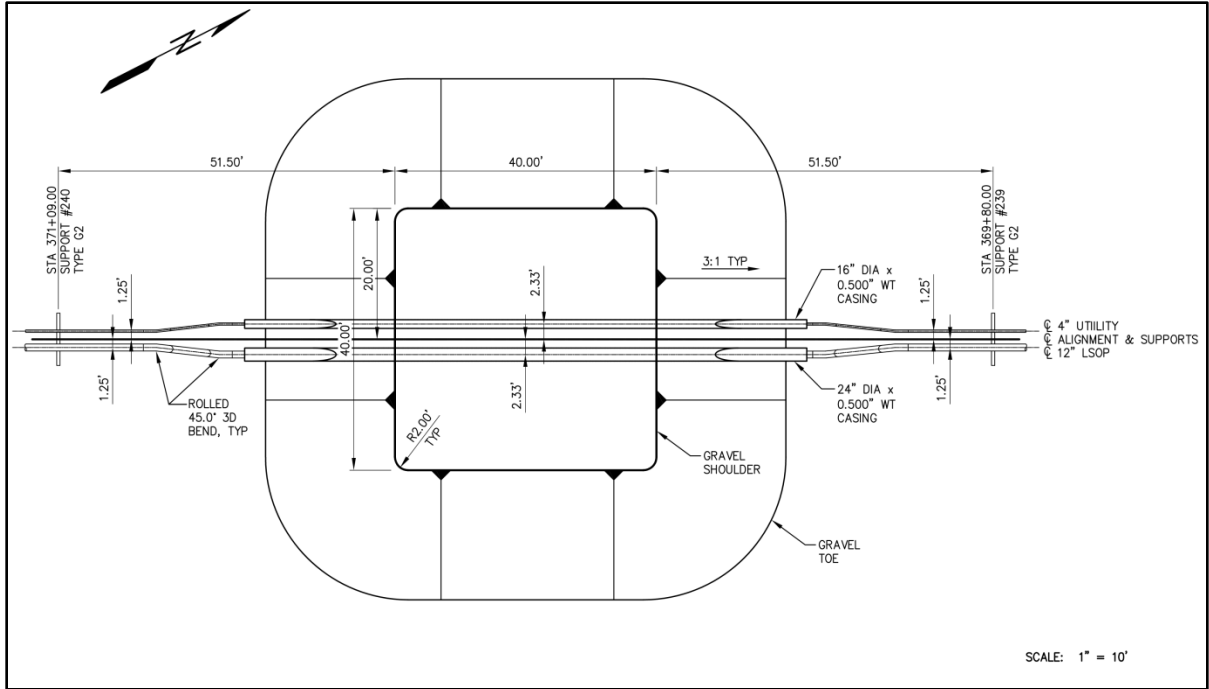

Figure 2.1.4-2. Badami Ice Road Crossing Pad, Plan View

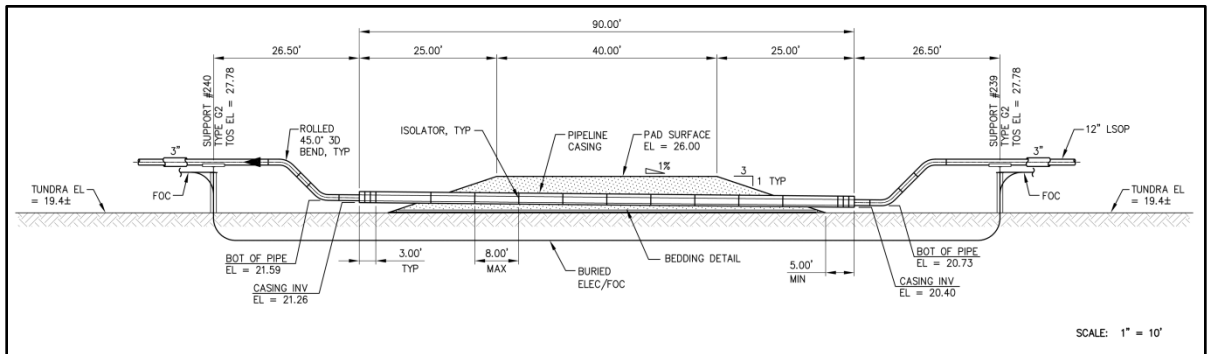

Figure 2.1.4-3. Badami Ice Road Crossing Pad, Section View

An approximately 0.7 acre (0.28 ha) gravel pad would be required where the Liberty Pipeline and Badami pipeline join (Badami tie-in pad). This would require roughly 3,500 cy of gravel (Figures 2.1.4-4. and 2.1.4-5, below).

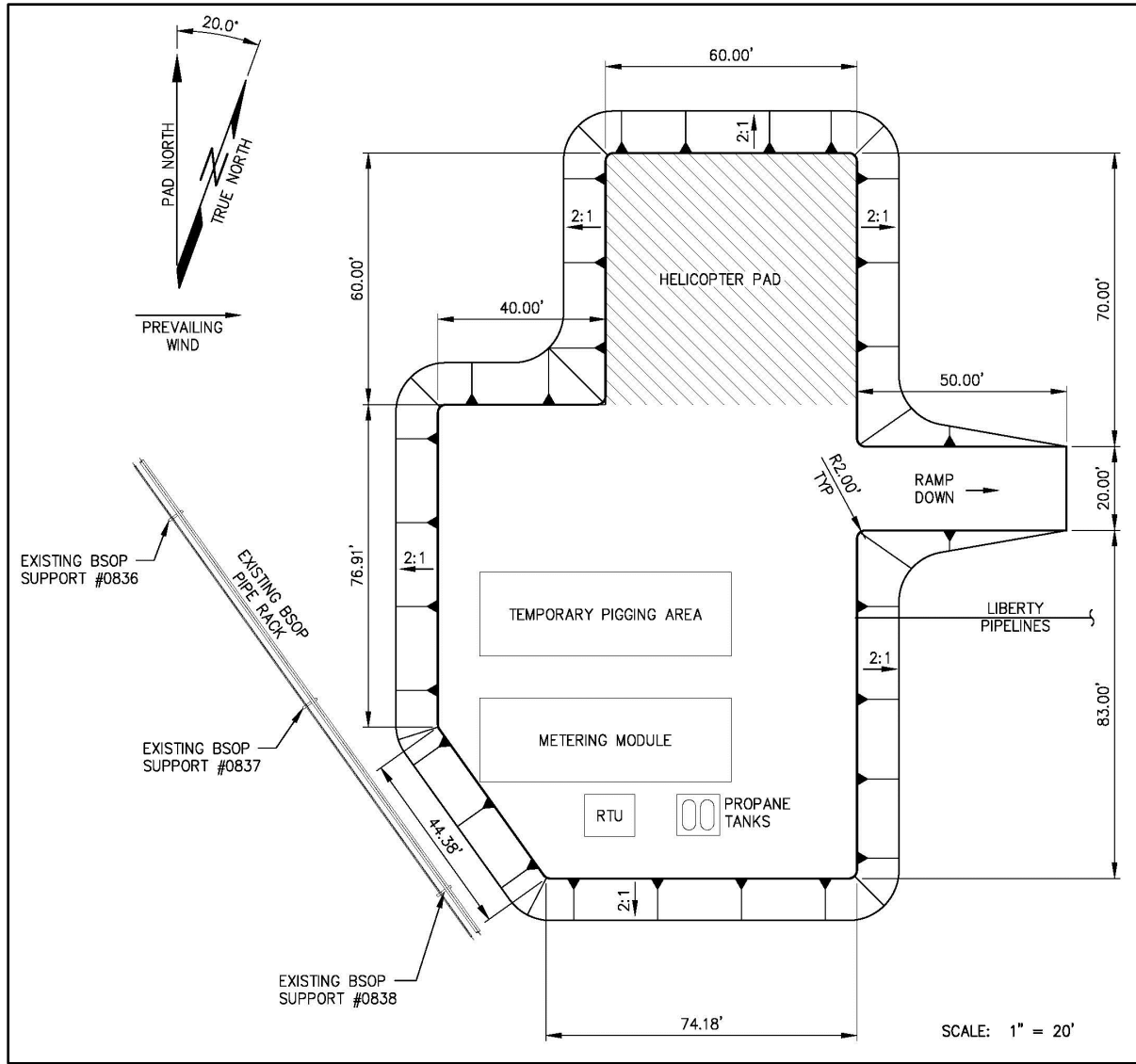

Figure 2.1.4-4. Onshore Tie-In Pad, Plan View

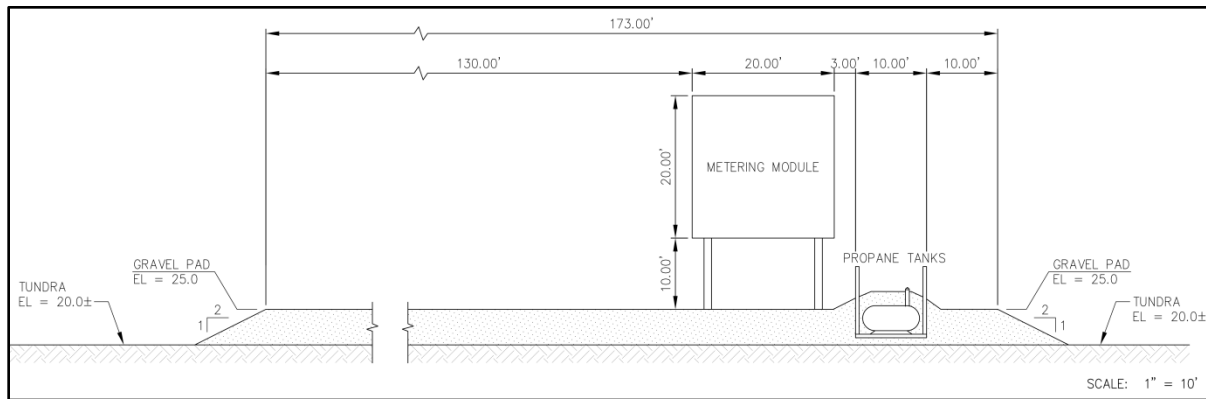

Figure 2.1.4-5. Onshore Tie-In Pad, Section View

The proposed onshore pipeline would cross the tundra for almost 1.5 miles (2.4 km). The single wall 12-inch (30.5 cm) pipeline would rest on 150 to 170 Vertical Support Members (VSMs), spaced

approximately 51 feet (15.5 m) apart to provide the pipeline a minimum 7 foot (2.1 m) clearance above the tundra. Pipeline expansion loops would be required roughly every 1,300 ft (396 m). See Section 7.5 of the DPP for additional detail.

The VSMS would be installed and the pipeline placed before the installation of the pigging facilities at the Badami tie-in pad (a ‘pig’ is a device that is forced through a pipeline by pipeline internal pressure for the purposes of displacing or separating fluids and cleaning or inspecting the line).

At the pipeline landfall (where the pipeline transitions from onshore to offshore), HAK would construct an approximately 1.4 ac (0.57 ha) trench to accommodate the installation of thermosiphons (heat pipes which circulate fluid based on natural convection to maintain or cool ambient ground temperature) along the pipeline and to protect against coastal erosion along the pipeline corridor. The proposed length of the onshore setback is approximately 350 ft (107 m), starting from the 4 foot (1.2 m) elevation to the daylight of the pipeline, to account for any potential ice ride-up associated with onshore sea ice movement. HAK estimates long-term (period from 1949 to 1995) erosion rates of about 2 ft (0.6 m) per year at the shore crossing location (Coastal Frontiers, 1996). The transition (daylight) point would account for the average long-term erosion rate and the maximum expected short-term erosion rate.

More information is available in the DPP, Section 7. A schematic for the pipeline landfall is shown below in Figure 2.1.4-6.

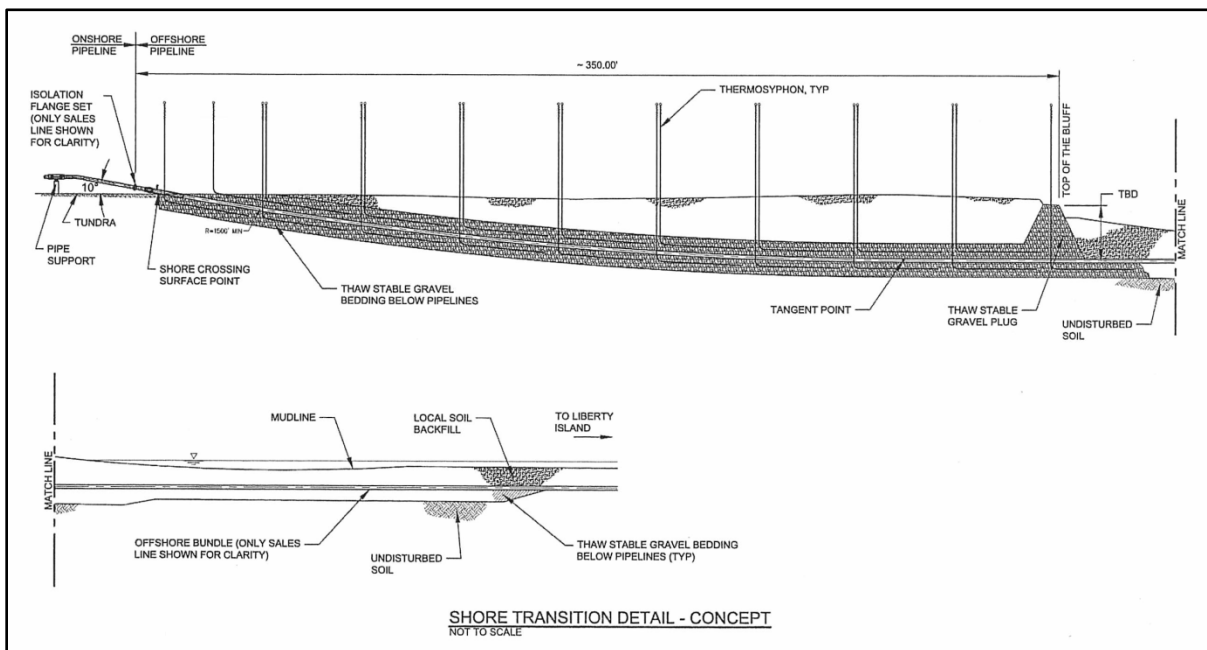

Figure 2.1.4-6. Pipeline Landfall Schematic, Section View

The subsea (offshore) section of the pipeline would be the PIP system described above; it would be constructed during the winter within a proposed temporary construction right-of-way (1,500 ft wide). The proposed minimum depth of cover over the pipeline bundle is nearly 7 ft below mudline. The target trench depth is 9-11 ft.

Offshore, construction would progress from shallower to deeper water for the approximately 5.6 mile marine portion of the pipeline, with multiple construction spreads. Construction would involve:

- Equipment, material and crew member mobilization
- Construction of the supporting ice road

- Cutting a slot through the ice, excavating a trench (including temporarily storage of excess materials)
- Preparing (welding and joining together) the pipeline bundle components
- Placement of the pipeline bundle in the trench
- Trench backfilling

The pipeline trench would be backfilled with the material removed during excavation using conventional equipment (backhoes, dump trucks, etc.). Some gravel or gravel bags may also be used as backfill for the transition trench.

More information is available in the DPP, Section 7.8 Offshore Pipeline Installation.

Disposal of Pipeline Trench Materials

HAK plans to place all dredged material back in the pipeline trench. Based on the estimated pipeline trench depth and the soil composition along the proposed pipeline alignment, all material would be suitable for backfilling the trench excavation.

2.1.5. Facilities Construction

The LDPI layout includes areas for drilling, production, production support, utilities, a camp, camp utility area, and a relief well area. Permanent structures on the LDPI would be supported by driven steel piles and/or slab on grade foundations. Rig mats (portable platform used to support equipment used in construction and other resource-based activities, including drilling rigs, camps, tanks, and helipad) may be used in some areas (e.g., storage containers).

The LDPI would have a helicopter landing pad and one dock to accommodate barges, hovercraft, and small boats. It would also have ramps for amphibious vehicle access. Offshore ice road transitions would occur around the LDPI bench perimeter.

The LDPI design includes a seawater treatment plant, a sanitary wastewater facility, and a potable water treatment plant. Wastewater would receive secondary treatment. Remaining sewage solids would be incinerated on-island or stored in enclosed tanks prior to shipment to the North Slope Borough (NSB) treatment plant in Deadhorse. Please refer to Section 2.1.9. for a full description of the wastewater treatment operations and discharges.

Power for the camp and utilities during construction would be generated by two diesel-fired generators for a maximum power output of 1.25 megawatts each. A redundant generator would be available for backup power generation. Chemicals stored on the LDPI would include diesel fuel, methanol, and other chemicals to support drilling and production.

The LDPI production facilities and camp would be powered by fuel gas-fired turbines once the third Liberty well (L-04) has been completed. The diesel-fired engines that were located on the LDPI during construction would remain on the LDPI to provide power to the facilities in the event of a power disruption from the fuel gas-fired turbines. The LDPI production facilities would include three gas-fired compressors.

HAK plans to truck most modules, buildings, and material for on-site construction to the ANS via the Dalton Highway, to be staged at West Dock, Endicott SDI, or in Deadhorse. HAK may contract sea-going barges during Years 2 – 4 to support construction and drilling operations that would transit through Dutch Harbor to LDPI. HAK estimates that one to two barges would be needed to make from two to five trips total per year during this phase. Barges transiting between Dutch Harbor and LDPI would also occur throughout the life of the project; HAK estimates that one trip every five years would be required. Barges transiting between West Dock or Endicott SDI to LDPI would also occur throughout the project life. Construction workers and materials may be based at Endicott SDI; a

hovercraft ramp and hangar would be installed there, and HAK may create a ramp to facilitate winter ice road access across the sea ice to the LDPI.

Other onshore facilities would include a gravel pad for pipeline support at the tie-in location to the Badami Pipeline, as described previously. A plan view and section view of these pads are shown in Section 2.1.4. Additional onshore support, mentioned above, would include use of water sources for ice roads and ice pad construction and development of a gravel mine site west of the Kadleroshilik River.

2.1.6. Drilling Operations

HAK would have 16 well slots, with the initial 11 to be drilled in Years 2 – 4; additional well slots would be available as backups or for potential in-fill drilling. HAK would drill 5-8 producing wells (to include any additional future completions), 4-6 water and/or gas injection wells, and up to two disposal wells at surface wellhead spacing of 15 ft between well slots. A location on the LDPI is also designated for drilling a relief well, if needed. HAK would use a conventional rotary drilling rig to drill the wells, and the Liberty drilling operations are expected to occur over a period of about 2 years, as described in Table 2-1.

The first well drilled would be a disposal well for the cuttings re-injection and waste mud. Rock cuttings and excess drilling mud from this well would be stored on site until the disposal well is completed and the grind and inject facility is commissioned. Alternatively, cuttings and drilling muds may be transported to an existing onshore site for disposal. The next well drilled would be a gas injector so that produced gas could be re-injected into the reservoir. Produced gas would be used as fuel gas and lift gas (i.e., reinjected gas used to increase fluid pressure). The third well drilled would be a producer. This well would be completed and connected to the processing facilities to allow the plant to start up.

The Liberty drill rig would initially be powered by a set of diesel-fired primary power generators and eventually converted to gas-fired primary power generators; HAK plans to power the drill rig, grind and inject facility and other drilling operations exclusively by diesel-fired equipment while the first three wells are being completed. Once the third well is complete, the LDPI drill rig, grind and inject facility, and production facilities would be powered by fuel gas-fired equipment with diesel-fired units available as backups in case the gas process plant shuts down. The drill rig would also be equipped with dual-fuel boilers, dual-fuel heaters, and a diesel-fired cold start engine.

Seawater, treated and comingled with produced water, would also be used for injection into the Liberty Reservoir in a process called waterflooding. Waterflooding, unlike fracking, does not fracture the reservoir to increase production. Instead, water is transferred to the reservoir from the surface down an injector well with the intention of pushing oil towards the producing well, enhancing oil production. This process maintains the pressure within the reservoir by filling pore space left vacant by initial oil production. The treated seawater would also be used to create potable water and utility water used at the proposed LDPI.

The drilling unit and associated equipment would be transferred by barge through Dutch Harbor or from West Dock to the LDPI in 3rd Quarter Year 2. Drilling is scheduled to begin the 1st Quarter of Year 3. Drilling would occur year-round, but drilling into the reservoir would be limited to ice-free (typically July 15th – September 1st) and solid-ice seasons (approximately November 15th – June 1st). This allows for periods when there is either solid ice to retain any spills above the ocean until cleaned up, or sufficiently open water to allow traditional, vessel based, oil spill response activities. All the wells are anticipated to be drilled and completed by the end of Year 5.

Each spring and fall, prior to soft/broken ice seasons, sufficient drilling consumables (i.e., drilling fluid, additives, lubricants, etc.) would be stockpiled on the LDPI to allow drilling through the periods when re-supply is limited to personnel, groceries, and small loads via helicopter or hovercraft.

A more detailed discussion of the sequence of drilling activities, including drilling unit mobilization, drilling operations, and seasonal drilling restrictions, as well as the drilling order of all wells, is provided in Section 8 of the DPP.

2.1.7. Production Operations

Production would commence once the initial facilities are constructed and the first three wells are drilled. Production, drilling, and facility installation activities would occur simultaneously until all the wells are drilled and in service.

The initial production rate is expected to be in the range of 10,000 to 15,000 barrels of oil per day (BOPD). As additional wells are brought online, the production rate is expected to peak at a rate between 60,000 and 70,000 BOPD. HAK anticipates it would take about 2 years after first oil to reach peak flow rate from the reservoir.

HAK estimates the economic life of the field at approximately 15 to 20 years, so the facilities and pipeline are designed for an operational life of 25 years based on design criteria appropriate to Arctic conditions (e.g., wave, ice, storm, seismic conditions, etc.). HAK plans to upgrade facilities (i.e., replacing equipment and/or piping) if the operational life of the Liberty Field exceeds 25 years.

More information about the Liberty reservoir is available in Section 3.1.3 of this DEIS, and in Section 4 of the DPP. Production operations are discussed in Section 11 of the DPP.

Ancillary Activities

HAK may conduct annual ancillary activities to include geohazard surveys (to identify conditions at or below the seafloor that are potentially hazardous) conducted with aerial reconnaissance surveys or stand-alone geophysical surveys. NMFS (2016a) describes the typical types of equipment and acoustic sources for geohazard surveys as:

- Single Beam Echosounders: 180 to 205 dB re 1 μ Pa at 1 m between 3.5 and 1,000 kilohertz (kHz)
- Multibeam Echosounders: 216 to 242 dB re 1 μ Pa at 1 m between 180 kHz and 500 kHz
- Side Scan Sonar: 194 to 249 dB re 1 μ Pa at 1 m between 100 and 1,600 kHz
- Subbottom Profilers And Single Channel Seismic: 200 to 250 dB re 1 μ Pa at 1 m between 0.2 kHz and 200 kHz
- Multichannel Seismic: 196 to 217 dB re 1 μ Pa at 1 m between 0 and 200 Hz.

HAK plans to complete annual geohazard surveys over the pipeline corridor or along the island perimeter to assess trends associated with strudel scour impacts, ice events or erosion. HAK would implement mitigation measures based on these surveys, such as filling in strudel scours, controlling shoreline or island erosion.

Additional monitoring (via remote operated vehicle or sidescan sonar) may occur if aerial reconnaissance surveys or other monitoring instrumentation indicates that the pipeline has been exposed due to a strudel scour event.

EPA and the Alaska Department of Environmental Conservation (ADEC) have issued general permits that would provide discharge authorization for geotechnical surveys and related activities, which result in a discharge of pollutants (e.g. sand, rock, sediments, muds, etc.) Those permits are as follows:

- EPA General NPDES General Permit #AKG-28-4300, Oil and Gas Geotechnical Surveys and Related Activities in Federal Waters of the Beaufort and Chukchi Seas; Effective Dates: 03/02/2015 - 03/01/2020 ADEC.

- ADEC Alaska Pollutant Discharge Elimination System (APDES) , General Permit AKG283100, Geotechnical Surveys in State Waters of the Beaufort and Chukchi Seas, Effective Dates: 05/01/2015 - 04-30-2020

Monitoring Activities

HAK would monitor various physical features of the Liberty Development, for example, ice conditions, bathymetry and trench conditions. Biological monitoring would be developed with agency input on an activity-specific, site-specific basis. More information is available in the DPP, Section 12.5 Environmental Monitoring and in Appendix C of this DEIS.

2.1.8. Decommissioning

At the time the project is no longer economically viable, HAK would either begin abandonment procedures according to the permit conditions and regulations in force at that time, or enter into negotiations to transfer ownership of the project to another entity.

The estimation of the end of economic field life depends upon predictions of future oil and gas prices and operating costs. The expected producing life of the Liberty field is 15 to 20 years. The minimum project operational life, which includes construction and decommissioning time, is estimated to be 25 years. See section 19 of the DPP for more information on decommissioning.

Winter & Summer Access

During the project life, including during decommissioning, onshore ice roads used to connect the mine site, construction areas, and LDPI would melt at breakup; stream and river crossings would be slotted to facilitate stream flow. Onshore ice road routes would be inspected the following summer for tundra damage and remediated as needed. Abandonment and rehabilitation of the onshore gravel pads would be completed according to applicable regulatory requirements. BOEM assumes that ice roads #1 - #3 would be constructed in Years 24 – 25 to support decommissioning.

As a conservative estimate, BOEM assumes that all summer (open water) transits for decommissioning would be equal to the vessel types and transits used during construction.

Gravel Mine

Abandonment and rehabilitation of the gravel mine site for Liberty would be described in a Mining and Rehabilitation Plan submitted for approval to the ADNDR and USACE. A proposed mine site reclamation section view has been included below.

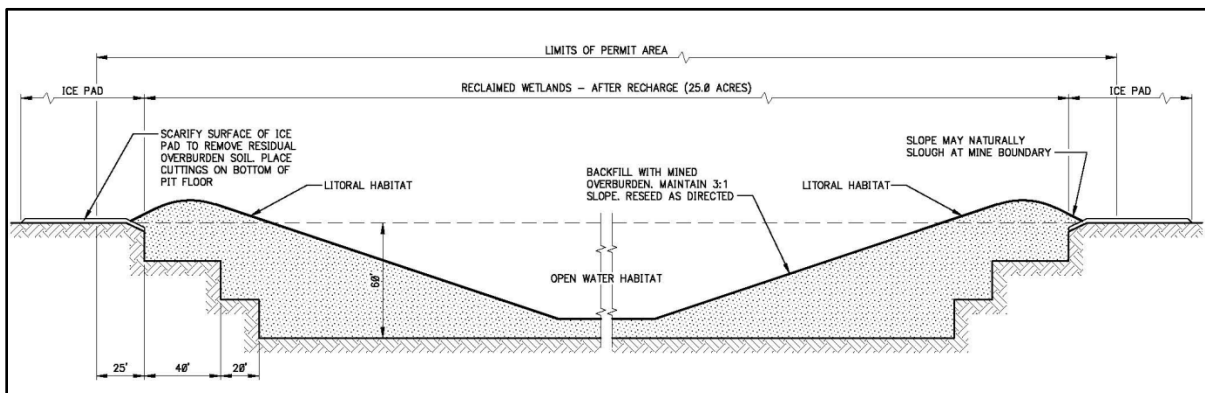

Figure 2.1.8-1. Proposed Mine Site Reclamation Section View

Island and Wells

While in the Production Operations phase, infill drilling or possible delineation success could extend the service life of the LDPI, production facilities, and pipeline system. BOEM conservatively assumes that in Year 23, HAK would initiate activities to modify and/or update the existing Liberty infrastructure to ensure safe continued use of the LDPI (and wells), production facilities, and pipeline system.

If this does not occur, HAK proposes to begin abandonment procedures when the project ceases to be economically viable, predicted to be Year 24 of the project life. The LDPI would be decommissioned at the end of field life (EOFL) and cessation of production, as defined by operating agreements, permits, and regulations. Removal of facilities and abandonment of the wells is expected to require two winter seasons over a span of 18 months (Years 24 – 25).

The procedure described below was used for Tern Island, which is located about 1.5 miles (2.4 km) from the proposed LDPI, and other exploration gravel islands built in the 1980s and 1990s to explore State and Federal acreage in the Beaufort Sea. Abandonment procedures have involved removing wellheads, pilings, and other structures to below the mudline, then plugging and abandoning the wells. Subsequently, the armor and sheet piles are removed, followed by testing the island for any contamination, remediating any contamination, and then allowing natural wave, ice, and current forces to erode the island.

The removed armor from the LDPI may be used to enhance hard bottom habitat, or removed from the project area and recycled to another use or disposed of in an approved manner. Special consideration would be given to any Boulder Patch communities that may have colonized the lower portions of the concrete slope armor. HAK would obtain approval of its decommissioning plan by submitting applications pursuant to regulations in effect at that time. Title 30 CFR 250.1703(a) and 30 CFR 250.1704 currently require the application be submitted to BSEE and meet the applicable requirements of 30 CFR Subpart Q, Decommissioning Activities. BSEE regulations provide specific requirements for well abandonment, but those are not prescriptive for LDPI abandonment. Removal is subject to the approval of the Regional Supervisor.

Laws and regulations pertaining to Alaska Department of Natural Resources (ADNR) and U.S. Army Corps of Engineers (USACE) approvals for this project also provide for discretion in termination and abandonment procedures.

Pipeline

At the end of the project life, decommissioning of the pipeline would be subject to both State of Alaska and Department of Transportation, Pipeline and Hazardous Materials Safety Administration (PHMSA) regulations. All lines would be de-energized and flushed prior to removal. The processes and standards for flushing are expected to be site-specific and would be incorporated into the final decommissioning plan. Site clearance work on State land would require removal of all materials, supplies, structures, VSMS, and installations from the location.

The buried subsea portion of the pipeline would be abandoned in place or continued for use by HAK or another entity after Liberty is depleted, after which time it would be abandoned in place. Following flushing, HAK would verify that all hydrocarbons or other contaminants have been removed, cut the ends of the pipeline off at the appropriate elevation, and permanently seal the ends. Marine lines would be identified to the U.S. Coast Guard for proper chart designations or aid to navigation marking, as appropriate. Additional details of decommissioning the subsea buried pipeline would be determined in the permitting and/or decommissioning approval process.

If the pipeline is not decommissioned in Years 24 – 25, the pipeline system could be operated as a common carrier. This would allow for HAK and/or another entity to use the pipeline for other future purposes after the Liberty reservoir has been depleted.

Facilities

Surface facilities include all equipment and structures associated with drilling, development, and production of the Liberty petroleum reserves. All modules, structures, pipelines, and supports are considered surface facilities.

All installed surface facilities associated with the Liberty Development would be removed. Surface facilities would be de-energized, flushed of any oil and chemical residues if necessary (not all the lines carry oil), and removed. Modules would be removed in a reverse process from installation and transported to an offsite location to be reused, recycled or disposed. Other installations would likely be removed by dismantlement.

2.1.9. EPA Permitting

The Proposed Action would require a National Pollutant Discharge Elimination System (NPDES) permit from EPA for the discharge of waste streams associated with the LDPI.

Section 301(a) of the Clean Water Act (CWA) provides that the discharge of pollutants to surface waters of the United States is prohibited except in accordance with a National Pollutant Discharge Elimination System (NPDES) permit. Section 402 of the Clean Water Act establishes the NPDES permit program, which provides the U.S. Environmental Protection Agency (EPA) and the authorized states the authority to control and limit the discharge of pollutants into waters of the United States. HAK has applied for an NPDES permit for the discharge of waste streams associated with the LDPI. The LDPI is located 4.78 nautical miles (8.85 kilometers) offshore in Federal waters of the OCS; therefore, the EPA is the NPDES permitting authority.

Ocean Discharge Criteria Evaluation

Section 403(c) of the CWA requires that the NPDES permits authorizing discharges into the territorial seas, the contiguous zones, and the oceans, including the outer continental shelf, comply with EPA's Ocean Discharge Criteria (40 CFR Part 125, Subpart M). The purpose of the Ocean Discharge Criteria Evaluation (ODCE) is to assess the discharges authorized under the NPDES permit and to evaluate the potential for unreasonable degradation of the marine environment based on the consideration of ten specific criteria.

The ten criteria are specified at 40 CFR Part 125.122, Determination of Unreasonable Degradation of the Marine Environment. The Director shall determine whether a discharge would cause unreasonable degradation of the marine environment based on consideration of:

1. The quantities, composition and potential for bioaccumulation or persistence of the pollutants to be discharged;
2. The potential transport of such pollutants by biological, physical or chemical processes;
3. The composition and vulnerability of the biological communities which may be exposed to such pollutants, including the presence of unique species or communities of species, the presence of species identified as endangered or threatened pursuant to the Endangered Species Act, or the presence of those species critical to the structure or function of the ecosystem, such as those important for the food chain;
4. The importance of the receiving water area to the surrounding biological community, including the presence of spawning sites, nursery/forage areas, migratory pathways, or areas necessary for other functions or critical stages in the life cycle of an organism;

5. The existence of special aquatic sites including, but not limited to, marine sanctuaries and refuges, parks, national and historic monuments, national seashores, wilderness areas and coral reefs;
6. The potential impacts on human health through direct and indirect pathways;
7. Existing or potential recreational and commercial fishing, including finfishing and shellfishing;
8. Any applicable requirements of an approved Coastal Zone Management plan;
9. Such other factors relating to the effects of the discharge as may be appropriate;
10. Marine water quality criteria developed pursuant to section 304(a)(1).

New Source Performance Standards

Discharges to surface waters of the United States associated with the oil and gas extraction point source category are regulated under 40 CFR Part 435, Subparts A-D, which were promulgated in 1979. Effluent limitation guidelines and new source performance standards for the offshore subcategory of the oil and gas extraction point source category were amended on January 15, 1993, and became effective on March 4, 1993 (40 CFR 435, Subpart A; 58 FR 12454). New oil and gas development and production operations where construction commenced after the effective date of applicable new source performance standards (NSPS) are considered new sources.

40 CFR § 122.2 defines “new source” as follows:

“New Source means any building, structure, facility or installation from which there is or may be a “discharge of pollutants,” the construction of which is commenced:

- a. After promulgation of standards of performance under §306 of CWA which are applicable to such source, or
- b. After proposal of standards of performance in accordance with §306 of CWA which are applicable to such source, but only if the standards are promulgated in accordance with §306 within 120 days of their proposal.”

The regulations at 40 CFR §122.29(b)(4) define what constitutes “construction” of a new source, stating that:

“Construction has commenced if the owner or operator has:

- (i) Begun, or caused to begin as part of a continuous on-site construction program:
 - (A) Any placement assembly, or installation of facilities or equipment; or
 - (B) Significant site preparation work including clearing, excavation or removal of existing buildings, structures, or facilities which is necessary for placement, assembly, or installation of new source facilities or equipment; or
- (ii) Entered into a binding contractual obligation for the purchase of facilities or equipment intended to be used in its operation with a reasonable time.”

EPA has determined the LDPI is a new source because construction would commence after the promulgation of new source performance standards in 1993.

In accordance with Section 511(c)(1) of the CWA and the EPA’s regulations for implementing the procedural provisions of NEPA at 40 CFR Part 6, issuance of NPDES permits for new sources are considered major federal actions subject to NEPA review.

In order to satisfy their NEPA compliance obligations associated with the issuance of an NPDES permit for the LDPI, the EPA has agreed to assist in the preparation of this DEIS as a cooperating agency pursuant to 40 CFR 1501.6.

NPDES permits would be required to implement the Proposed Action or any of the other Alternatives considered in the EIS that fall under EPA authority, except for the No Action Alternative. EPA has identified the following alternatives for its own NPDES permitting action:

- **EPA's Action:** Issue an individual NPDES permit to HAK for requested waste streams associated with the Liberty Project, in accordance with the statutory/regulatory-based requirements described below.
- **EPA's No Action:** Do not issue an NPDES permit to HAK for requested waste streams associated with the Liberty Project.

Wastewater Discharges under the Proposed Action

All permitted waste streams would be discharged from the LDPI into Stefansson Sound in the Beaufort Sea. A description of the requested waste streams and treatment processes is provided below.

Sanitary and Domestic Wastewater (Outfall 001a; Contingency Discharge)

Sanitary wastes from offshore oil and gas facilities are comprised of the human body waste discharged from toilets and urinals. Domestic waste, or graywater, originates from sinks, showers, laundries, safety showers, eye-wash stations, hand-wash stations, food preparation areas, galleys, and other domestic sources that do not include wastes from toilets, urinals, hospitals, and cargo spaces.

HAK intends to use a membrane bioreactor (MBR) with ultraviolet (UV) disinfection to treat the sanitary and domestic wastewater at LDPI. The MBR treatment process consists of screening, a suspended growth biological reactor (similar to conventional activated sludge systems), membrane filtration to separate and confine solid particles, and disinfection (US EPA, 2007). MBRs have demonstrated high removal efficiencies for contaminants such as nitrogen, phosphorus, bacteria (e.g. fecal coliform), biological oxygen demand, and total suspended solids. HAK has indicated an average daily flow of approximately 5,000 gallons (18,927 liters (L) per day (gpd) and a maximum daily flow of approximately 20,000 gpd (75,235 L).

HAK has indicated this would be a contingency discharge. During the first two years of construction, prior to completion of a disposal well, sanitary and domestic wastewater would be hauled offsite to an onshore disposal facility. Once the disposal well is available at the LDPI, HAK intends to discharge the sanitary and domestic wastewater through injection into the disposal well. HAK has requested this contingency discharge for those times when the disposal well is not operational due to maintenance or other issues.

Potable Water Treatment Reject Wastes (Outfall 001b; Contingency Discharge)

Potable water reject waste is the residual high-concentration brine produced during the distillation of seawater. It has a chemical composition and ratio of major ions similar to the influent seawater, but with significantly higher concentrations.

HAK intends to use vapor-compression/distillation technology to produce potable water at the LDPI. Seawater is boiled inside a bank of enhanced surface tubes located on one side of the heat transfer surface. The excess feed water that does not evaporate (blowdown) contains concentrated dissolved solids and salts (brine) which are nearly twice the concentration of ambient seawater. A continuous injection of maintenance chemicals would be added during the process. Periodic injection of an acid and/or descaler would be used to remove mineral buildup in the system. HAK has indicated an

average daily flow of approximately 5,000 gpd (18,927 L/d) and a maximum daily flow of approximately 20,000 gpd (75,235 L/d).

HAK's NPDES permit application (December 3, 2016) states that the potable water reject waste discharge would be a contingency discharge. During the first two years of project construction, prior to Liberty facility installation, potable water would be hauled to the project location from an existing onshore source. Once the disposal well is available at the LDPI, HAK anticipates comingling the sanitary and domestic wastewater effluent with the potable water treatment plant effluent, and discharging both waste streams into the disposal well. HAK has requested this contingency discharge for those times when the disposal well is not operational due to maintenance or other issues.

Seawater Treatment Plant Wastewater (Outfall 002; Ongoing Discharge)

The overall purpose of the seawater treatment plant (STP) is to provide treated seawater for injection into the petroleum reservoir to maintain formation pressures and allow secondary oil recovery from production wells. The STP unit operations consist of a desander, coarse strainer, fine media filters, and a continuous seawater dump that allows seawater to pass through or be shunted for use in backwashing operations. The operation of the STP results in one continuous discharge through Outfall 002, which consists of the residual high-concentration brine and filter backwash produced during the treatment processes at the seawater treatment plant and a small volume of seawater to transport the solids to the disposal point. It has a chemical composition and ratio of major ions similar to seawater, but with significantly higher concentrations.

The proposed system has been designed to minimize the discharge of residual chemicals. There would be an amount (yet to be determined) of sodium hypochlorite discharged directly to the receiving water during backwash of the coarse and fine filters and some residual coagulant chemicals that may be used during periods of high suspended sediment load that occur during spring break-up and during summer storm events. The use of dechlorination is being considered to reduce the amount of total residual chlorine being discharged to the marine environment. Other chemicals used during the treatment process such as biocides, oxygen scavengers, scale/corrosion inhibitors, etc. would be utilized downstream of the filter backwash processes and, therefore, would not be introduced to the marine discharge, but would be injected as part of the enhanced oil recovery process.

HAK has indicated that the daily maximum discharge from the STP would be approximately 1.1 Million Gallons (4.2 ML) per Day (MGD) with an average daily discharge rate of 0.94 MGD (3.6 ML per day). The unit operations have been designed to minimize the frequency of backwashing/flushing, however, the ultimate frequency for backwash is a function of the solids loading in the feed to the system. If there is a high solids loading due to sand being sucked into the pump pit (e.g., storm conditions) or there is a high concentration of organic material (e.g., algal bloom) the backwash frequency may increase and the discharge rate and concentration of TSS may also increase.

Based on the available background TSS data, the observed spatial and temporal variability, it is reasonable to assume that average background TSS concentrations near the STP influent pipe may be approximately 30 mg/L. Furthermore, if it is assumed that all of the incoming seawater solids are removed, and the average daily discharge rate is 0.94 MGD (3.6 ML per day), then the total combined average effluent TSS concentration is expected to be approximately 140 mg/L. However, given the potential for variable concentrations of TSS in the receiving water environment due to naturally occurring seasonal events (e.g. algal blooms, ice break-up, large and sudden sediment loading from nearby freshwater rivers, and storm surges) and based on limited data from comparable facilities operating and discharging to the Beaufort Sea, HAK estimates that the average daily TSS concentration would be 250 mg/L and the maximum daily TSS concentration would be 1,000 mg/L (Hilcorp, December 2016 NPDES Permit Application).

The STP facility installation on the LDPI would not begin until late in second year or early in the third year of the project construction, therefore, there would be no discharge of STP effluent until that time.

Construction Dewatering Wastewater (Outfall 003; Contingency Discharge)

Construction dewatering is the removal of water from excavated areas where precipitation and/or snowmelt water accumulates and hinders the construction activity. Construction dewatering is primarily related to trenching activities while installing or repairing utilities and pipelines, but may also be related to other activities such as foundation or vertical support member installations. The most common methods for dewatering include submersible pumps, wells, well points, and vacuum trucks for small volumes.

While no flow volume has been specified for construction dewatering activities located at LDPI, HAK has indicated construction dewatering discharges would be minimal due to the majority of the project construction occurring during the winter. Construction dewatering may be required on the island if construction activities such as land farming or facility installation are occurring during the spring thaw, approximately May to June. When the disposal well is completed, in approximately Year 3 of project development, construction dewatering effluent would be injected. Therefore, discharges from construction dewatering activities are expected to occur intermittently during Years 1 – 3, at which point the waste stream would be injected into the disposal well.

Secondary Containment Dewatering Wastewater (Outfall 004; Contingency Discharge)

Secondary containment areas are diked or bermed areas around hydrocarbon tanks, tank farms, fuel transfer stations, tanker truck loading racks, and for the storage of non-petroleum chemicals, which provide an emergency storage area and help to prevent accidental spills from reaching the environment or nearby receiving waters. These areas are susceptible to rain or snowmelt accumulation.

HAK has requested authorization to discharge storm water (rainfall & snowmelt) accumulated in areas of secondary containment (i.e., diked or bermed areas) surrounding tanks and other areas utilizing secondary containment structures. No flow volume has been specified, but HAK has indicated that, as with construction dewatering, secondary containment dewatering would be required primarily during the spring thaw, approximately May to June. Discharge of secondary containment dewatering may occur during the first two years of construction. Once the disposal well is completed, in approximately Year 3 of project construction, secondary containment dewatering generated on the island would be injected. Therefore, discharges from secondary containment dewatering activities are expected to occur intermittently during Years 1 – 3, at which point the waste stream would be injected into the disposal well.

2.1.10. USACE Permitting

The following proposed activities would require a permit from the Corps because they would impact Waters of the U.S. (WOUS). The following activities are subject to Section 404 of the Clean Water Act:

- Development of a 25 ac (10 ha) gravel mine site (discharge of fill into jurisdictional wetlands)
- Construction of the tie-in pad, totaling 0.7 ac (0.28 ha) (discharge of fill into jurisdictional wetlands)
- Construction of ice road crossing pad, totaling 0.15 ac (0.06 ha) (discharge of fill into jurisdictional wetlands)
- Construction of VSMs (footprints) to support the elevated onshore pipeline over 1.5 miles (2.4 km), totaling 0.03 ac (0.01 ha)(discharge of fill into jurisdictional wetlands)

- Construction of the pipeline landfall trench, totaling 1.4 ac (0.57 ha) discharge of fill into jurisdictional wetlands)
- Construction of the portion of pipeline located within the Territorial Seas, totaling 4.5 miles and 33 ac (13.4 ha) the discharge of fill below mean high tide in Navigable Waters (the Beaufort Sea))

The construction of the 4.5 miles (7.2 km) portion (33 ac (13.4 ha)) of pipeline within the Territorial Seas is subject to not only Section 404 of the Clean Water Act jurisdiction, but also to Section 10 of the Rivers and Harbors Act.

A Department of the Army permit under Section 10 of the Rivers and Harbors Act (as extended by section 4(f) of the Outer Continental Shelf Lands Act of 1953 as amended (43 U.S.C. 1333(e))) would also be required for the construction of the 24 ac (9.7 ha) artificial island and 1.1 miles (8 ac) of the pipeline on the Outer Continental Shelf. This work would not be subject to Section 404 of the Clean Water Act.

Therefore, the Proposed Action would result in 27.28 ac of impacts subject to Section 404 only (onshore impacts), 33 ac (13.4 ha) subject to both Section 404 and Section 10 (Territorial Seas impacts), and 32 ac (12.9 ha) subject to Section 10 only (OCS impacts). An Individual Permit would be issued under Section 404 and Section 10 authorities.

2.1.11. NMFS Permitting

In 1972, Congress enacted the Marine Mammal Protection Act (MMPA), which puts a prohibition on the take of marine mammals, with certain exceptions; one of which is the issuance of ITAs (16 USC 1371, 50 CFR Subpart 1).

Under the MMPA, the ‘taking’ of marine mammals, incidental or otherwise, without a permit or exemption is prohibited. Among the activities exempt from the MMPA’s moratorium on the take of marine mammals is subsistence hunting of marine mammals by Alaska Natives (Section 101(b)). Among the exceptions allowed to the moratorium on marine mammal takes (as stated in Sections 101(a)(5)(A) and (D)) is for the incidental, but not intentional, “taking,” by U.S. citizens, while engaging in an activity (other than commercial fishing) of small numbers of marine mammals within a specified geographical region. The MMPA directs the Secretary of Commerce to authorize the take of small numbers of marine mammals provided that the taking would have a negligible impact on such species or stock, would not have an unmitigable adverse impact on the availability of such species or stock for taking for subsistence uses, and the permissible methods of taking and requirements pertaining to mitigation, monitoring, and reporting are set forth. Additionally, pursuant to Section 101(a)(5)(D) of the MMPA monitoring plans are required to be independently peer reviewed where the proposed activity may affect the availability of a species or stock for taking for subsistence uses.

The term “take” under the MMPA means “to harass, hunt, capture, or kill, or attempt to harass, hunt, capture, or kill any marine mammal.” The MMPA further defines “harassment” as “any act of pursuit, torment, or annoyance which (i) has the potential to injure a marine mammal or marine mammal stock in the wild [Level A harassment]; or (ii) has the potential to disturb a marine mammal or marine mammal stock in the wild by causing disruption of behavioral patterns, including, but not limited to, migration, breathing, nursing, breeding, feeding, or sheltering [Level B harassment].”

Given the widespread presence of several species of marine mammals in the Beaufort Sea and the nature of oil and gas production facility construction and operational activities, there is the potential that some activities associated with HAK’s LDPI may result in the take of marine mammals through sound and/or ice road construction activities. Because of the potential for these activities to “take” marine mammals, HAK may choose to apply for an Incidental Take Authorization (ITA).

In order to satisfy their NEPA compliance obligations associated with the issuance of an MMPA ITA for the Liberty DPP, NMFS has agreed to assist in the preparation of this DEIS as a cooperating agency pursuant to 40 CFR 1501.6.

NMFS may issue an MMPA ITA in connection with HAK's implementation of the Proposed Action or any of the other Alternatives considered in the EIS, except for the No Action Alternative.

In addition to the Project Alternatives described in detail below, NMFS has identified the following alternatives for its own MMPA ITA action:

- **NMFS' Action:** Issuance of ITAs under Sections 101(a)(5)(A) and (D) of the MMPA for the incidental taking of marine mammals during construction and operation of the LDPI.
- **NMFS' No Action:** NMFS would neither promulgate requested regulations nor issue authorizations under the MMPA relating to the potential taking of marine mammals incidental to construction and operation of the LDPI.

2.2. Alternatives

2.2.1. Alternatives Selection Process

To develop Alternatives to analyze in this DEIS, BOEM considered, through the lens of the Purpose and Need of the project: public scoping comments, input from Cooperating Agencies and tribal consultations, previous NEPA evaluations of Liberty exploration and development plans done by BOEM (formerly MMS), and current conditions in North Slope oil and gas development.

Alternatives to the 2002 Liberty Development and Production Plan Final Environmental Impact Statement (hereafter 2002 MMS) were developed by MMS and its cooperating and participating agencies (USACE, EPA, USFWS, NOAA, USCG, NSB and State of Alaska) by considering the same sources as described above. The alternatives covered the full range of reasonable development scenarios while addressing specific concerns associated with components of the proposed Liberty Development Project.

Also considered in the Alternatives development for this DEIS are the changes to existing infrastructure and operations on the North Slope since the 2002 MMS Liberty EIS was completed. Land status, oil field practice, technology, and regulatory controls have changed and evolved. New information has been collected, including biological studies, oil and gas resource updates, and subsistence surveys. Several comprehensive NEPA analyses evaluating North Slope development have also been completed, including the 2012 Point Thomson EIS, NOAA's 2016 Programmatic EIS concerning Effects of Oil and Gas Activities in the Arctic Ocean, the 2012 BLM NPR-A EIS, and multiple environmental assessments for ancillary activities in the Beaufort Sea.

The Alternatives development process was also informed by comments received during the scoping period for the current EIS. Public scoping meetings were held in Anchorage, Fairbanks, Utqiagvik (previously Barrow), Kaktovik, and Nuiqsut during November 2015. Further public and Cooperating Agency input was received through scoping comments posted to regulations.gov in response to (80 *FR* 57873, September 24, 2015). Commenters and cooperators expressed concern and provided information about potential impacts to subsistence, benefits to local economies, effects of increased sedimentation or changing currents on the Boulder Patch, impacts to migratory birds and their habitat due to the new proposed gravel mine site, impacts to marine mammals from noise associated with drilling and production on the LDPI, impacts to area resources and communities from an accidental oil spill, and the contributions of the project to climate change. The Boulder Patch is an ecologically important area within Stefansson Sound generally defined by having a greater than 10% cover of small boulders and cobblestone on the benthic surface (Martin and Gallaway, 1994), which supports the richest and most diverse biological communities known in the Beaufort Sea (Dunton, Reimnitz, and Schonberg, 1982). See Section 3.2.1 Lower Trophics for more information.

BOEM held a series of meetings with the Cooperating Agencies on this DEIS to develop, screen, and select alternatives for full analysis in the DEIS. Cooperating Agencies include:

- Bureau of Land Management
- Bureau of Safety and Environmental Enforcement
- Environmental Protection Agency
- National Marine Fisheries Service
- North Slope Borough
- Pipeline and Hazardous Materials Safety Administration
- State of Alaska
- US Army Corps of Engineers
- US Coast Guard
- US Fish and Wildlife Service

Each potential alternative suggested during this process - whether analyzed in the 2002 EIS, suggested by commenters during scoping, suggested by Cooperating Agencies, or identified internally by BOEM analysts – was subjected to a screening process that considered technical feasibility, economic feasibility, and ability to meet the Purpose and Need. Based on this e screening process, BOEM concluded that the action alternatives described below in Sections 2.2.3 through 2.2.6 are reasonable alternatives to HAK’s proposed Liberty Development Project. Alternatives which were “screened out” during this process are described in Section 2.3 as Alternatives Considered but Not Carried Forward for Further Analysis.

A comparison of the alternatives is found in Tables 2.2.1-1 2.2.1-5.

2.2.2. Alternative 1 (Proposed Action)

Under this alternative, BOEM would approve the proposed DPP and authorize HAK to proceed with the Liberty Project as described in section 2.1. The Liberty Project would be a self-contained offshore drilling and production facility located on an artificial gravel island called the LDPI with a pipeline to shore. Figure 2.2.2-1 illustrates the Proposed Action Area.

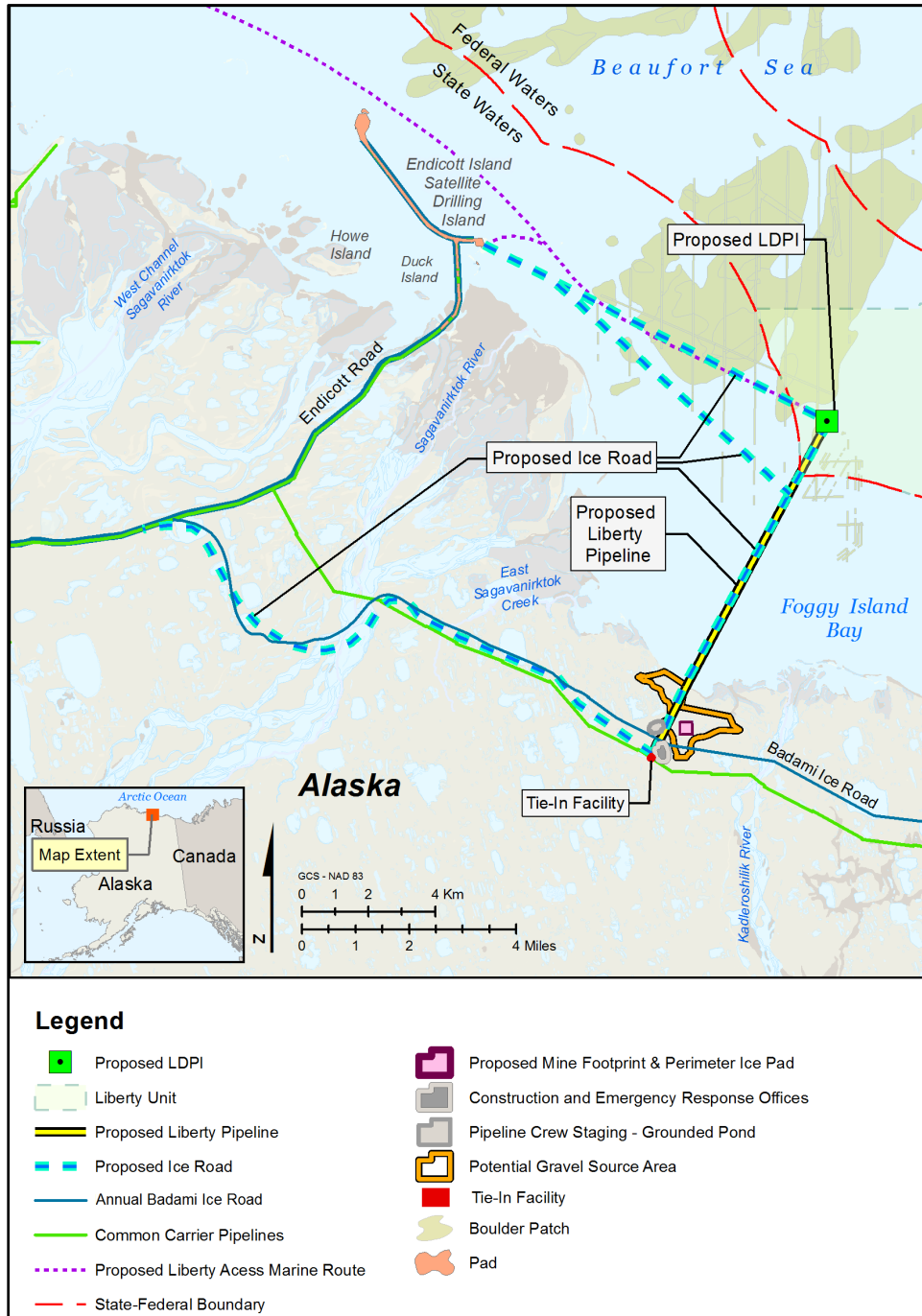

Figure 2.2.2-1. Proposed Action

2.2.3. Alternative 2 (No Action)

Under this Alternative, the Proposed Action would not be approved and the actions described in the Liberty DPP would not take place. No oil and gas resources would be extracted from the OCS, and none of the impacts or benefits that would be attributable to the Proposed Action would be realized.

Implementation of this alternative would not require any regulatory authorizations or permits from any of the Cooperating Agencies on this EIS

2.2.4. Alternative 3 (Alternate LDPI locations)

During scoping, BOEM received public comments suggesting the LDPI be relocated in order to avoid or reduce impacts to Boulder Patch communities. Based upon this input, BOEM requested that HAK identify possible alternate island locations that maintain the technical feasibility of the project and either:

1. Minimize impacts to the Boulder Patch from turbidity and sedimentation associated with construction activities, and/or
2. Move the LDPI and other project components as far from the densest areas of known Boulder Patch habitat as practicable.

Based on these public comments and responses from HAK, BOEM developed two reasonable sub-alternatives.

The first, Alternative 3A, would relocate the LDPI to a site about one mile (1.6 km) to the east, which would result in the island about one mile further away from the densest areas of the Boulder Patch.

Alternative 3B places the LDPI approximately 1.5 miles (2.4 km) closer to shore into State of Alaska waters. This location is 1.5 miles further away from the densest areas of the Boulder Patch.

For a comparison of the components of Alternative 3A and 3B with the Proposed Action, see Tables 2.2.4-1 through 2.2.4-5.

2.2.4.1. Alternative 3A: Relocate LDPI Approximately One Mile East

This alternative would increase the distance of the LDPI from the densest parts of the Boulder Patch by about 1 mile.

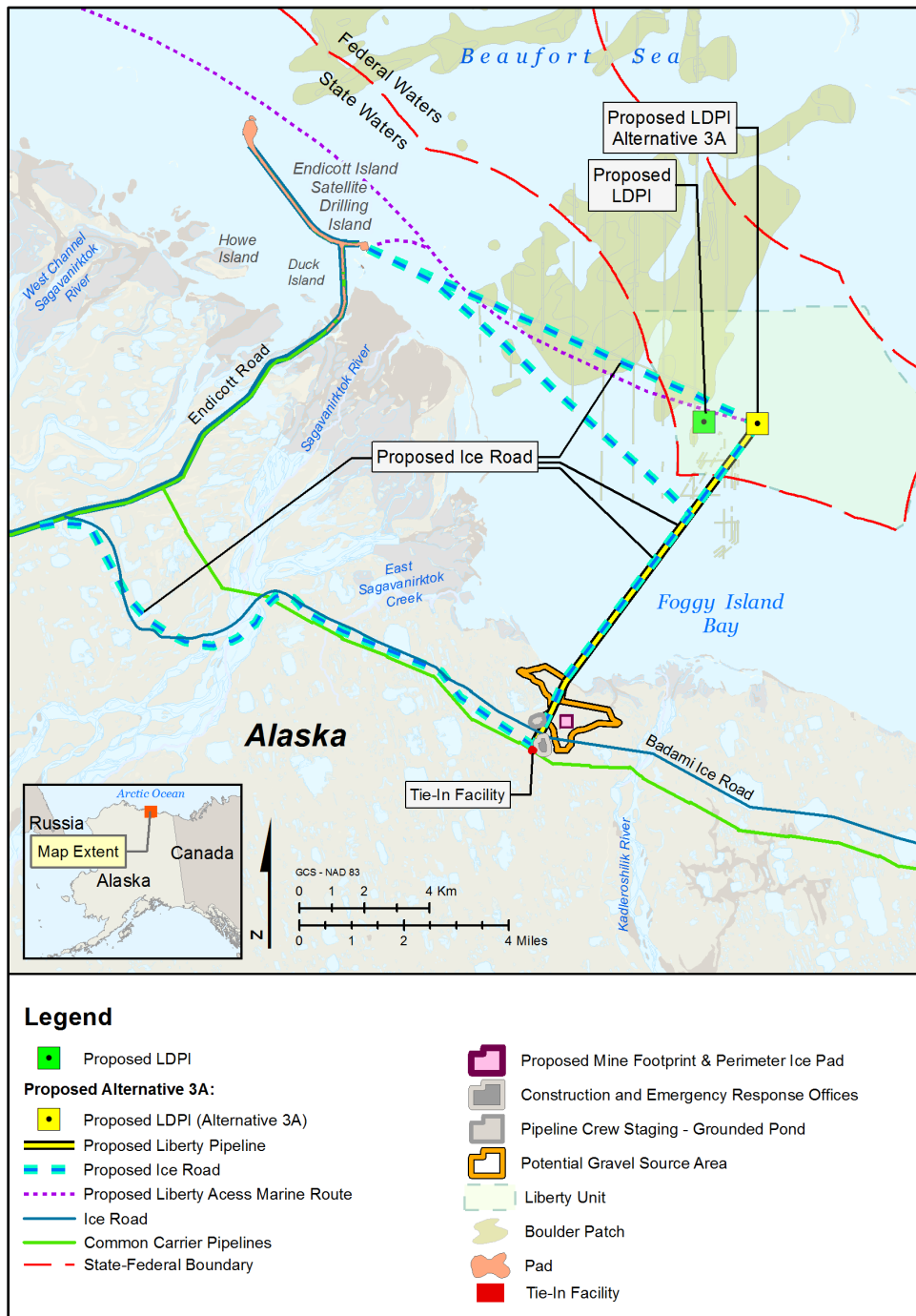

Figure 2.2.4-1. Alternative 3A: LDPI Moved Approximately 1 Mile East.

Winter & Summer Access

Ice road construction activities would remain the same under Alternative 3A as for the Proposed Action, although the location and length of the ice roads would differ (shown in Figure 2.2.4-1). The ice roads would be approximately 36 miles (57.9 km) in total. Summer access would involve the use

of the same marine vessels as described in the Proposed Action. The marine transit route from West Dock to LDPI (3A) is about 26 miles (41.8 km); from Endicott SDI to LDPI (3A) is about 8.7 miles (14 km).

Gravel Mine Site Development

Alternative 3A would require more gravel than described in the Proposed Action to construct the Liberty infrastructure because the water depths at this site are deeper than at the Proposed Action site. This would increase the depth of the gravel mine by about 4 ft (1.2 m) (46 – 64 ft (14-19.5 m)), as compared to the Proposed Action. This site is a 13 mile (20.9 km) round trip from the proposed gravel mine site, which would require approximately 14 trucks working for 82 days, using approximately 410,000 gallons (1,552,000 L) of fuel—a greater overall use of equipment and fuel over a greater amount of time than for the Proposed Action (see Table 2.2.7-1 through 2.2.7-5 for full comparison of alternatives).

Island Construction

The LDPI would be located in deeper water than the Proposed Action (21 ft 6.4 m) instead of 19 ft (5.8 M)) and have a sea bottom footprint 0.6 ac larger to maintain the proper side slope of the island (about 24.5 ac (9.9 ha) instead of 24 ac (9.7 ha)). The estimated amount of gravel needed for Alternative 3A LDPI would be 999,000 cy instead of less than 950,000 cy for the Proposed Action. This island would take approximately 82 days to construct and about 10% more water to construct.

Pipeline Construction

Under this alternative, the offshore portion of the pipeline would be moved one mile closer to the Kadleroshilik River Delta. The location of the on-shore Badami pipeline tie-in would not be affected (see Figure 2.2.4-1). The offshore pipeline in this alternative would be 7.7 miles (12.4 km) long (6.2 miles (10 km) offshore). The resulting trench volume would be approximately 244,000 cy.

Approximately 0.25 mile (0.4 km) of this offshore pipeline route would transverse through an area with a 100% possibility of overflood occurrence (overflowing is the fluvial process that causes strudel scour; see Section 3.1.2.4 for more information). Overflowing increases the risk of a strudel scour event, which could cause upheaval buckling (upward bending of the pipeline), wear, and possible pipeline rupture. Pipeline design changes would be necessary to contend with these risks. For the purpose of this analysis, BOEM assumes for Alternative 3A that the pipeline would be buried nearly 2 ft (0.6 m) deeper than the Proposed Action pipeline to minimize potential for a strudel scour to contact the pipeline. This additional depth would require additional time spent excavating. Another potential design change to prevent strudel scour damage would be to increase the wall thickness of the pipeline to prevent upheaval buckling.

Facilities Construction

The surface area and the number/type of facilities located on the LDPI would remain the same as the Proposed Action.

Drilling Operations

This alternative would decrease the average wellbore length to approximately 13,500 ft (3,962 m). The wellbore length of the Proposed Action is approximately 13,900 ft (4,237 m).

Production Operations and Decommissioning

Production operations and Decommissioning under Alternative 3A would remain the same as in the Proposed Action.

2.2.4.2. Alternative 3B: Relocate LDPI Approximately 1.5 Miles to the Southwest

This alternative would decrease the distance between the proposed LDPI and the shore by 1.5 miles (2.4 km). It would also increase the distance of the LDPI from the densest parts of the Boulder Patch by 1.5 miles.

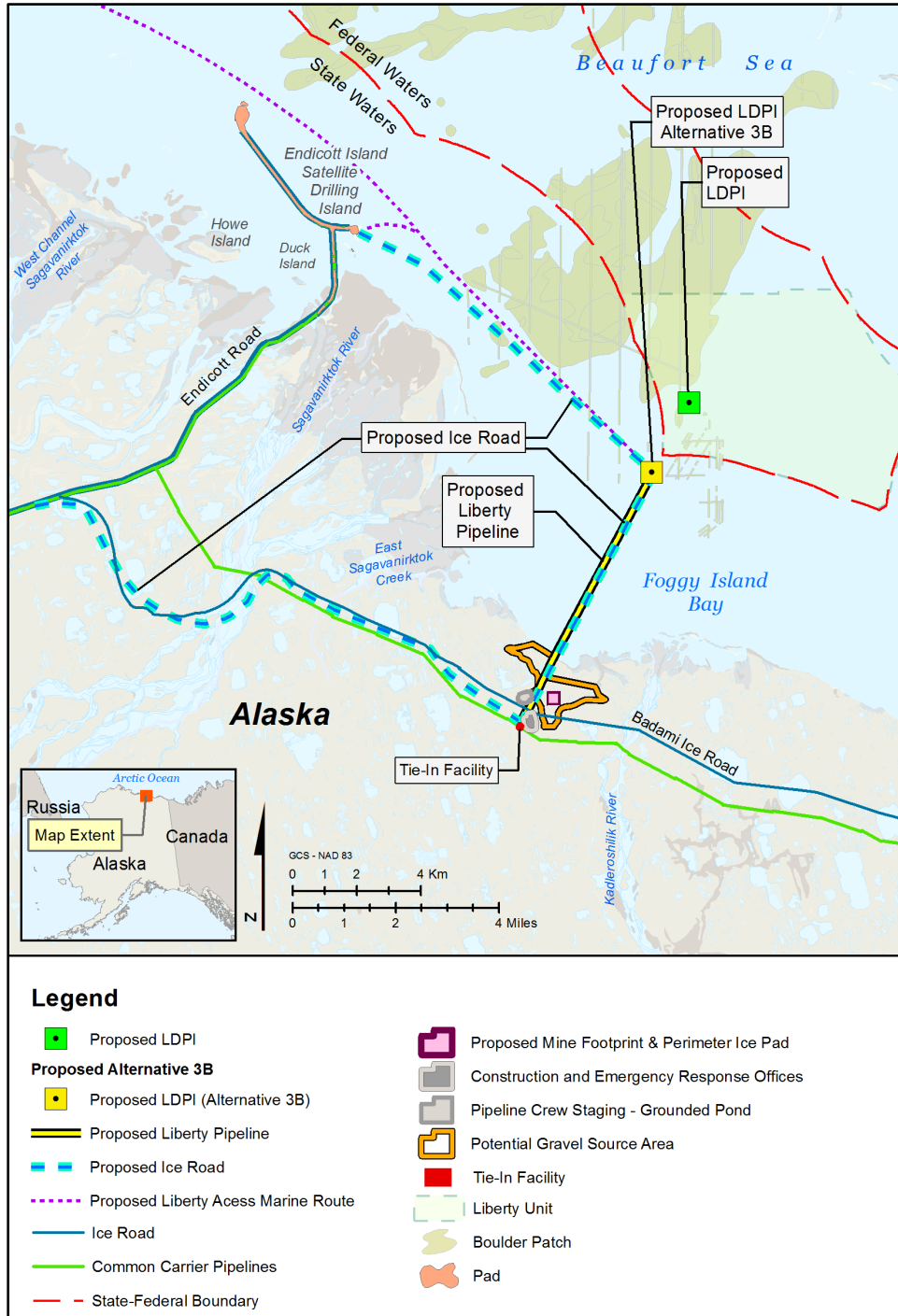

Figure 2.2.4-2. Alternative 3B: LDPI Moved Approximately 1.5 Miles to the Southwest.

Winter & Summer Access

Ice road construction activities would remain the same under Alternative 3B as for the Proposed Action, although the location and length of the ice roads would differ (see Figure 2.2.4-2.). The ice roads would be approximately 27 miles (43.5 km) in total. Summer access would involve the use of the same marine vessels as described in the Proposed Action. The marine transit route from West Dock to LDPI (3B) is about 25 miles (40 km); from Endicott SDI to LDPI (3B) is about 7.6 miles (12.2 km).

Gravel Mine Site Development

Alternative 3B would require about 1,178,000 cy of gravel to construct the Liberty infrastructure compared to less than 1,500,000 cy of the Proposed Action because the water depths at this site are shallower than at the Proposed Action site. This could decrease the depth of the mine site by about 4 ft (1.2 m) (38 – 56 ft (11.6-17.1 m)). This site is a 10 mile (16 km) round trip from the proposed gravel mine site, which would require approximately 14 trucks working for 62 days, using about 310,000 gallons (1,173,000 L) of fuel (see Tables 2.2.7-1 through 2.2.7-5 for comparison of alternatives).

Island Construction

The surface area and the number/type of facilities located on the LDPI would remain the same as the Proposed Action. The LDPI would be located in shallower water than the Proposed Action (17 ft instead of 19 ft) and have a sea bottom footprint 0.6 ac smaller (roughly 23.4 ac (9.5 ha) instead of 24 ac (9.7 ha)) to maintain a 3:1 side slope of the island. The estimated amount of gravel needed for Alternative 3B LDPI would be about 854,700 cy compared to less than 950,000 cy for the Proposed Action.

Pipeline Construction

This alternative would not alter the location of the on-shore Badami pipeline tie-in or the proposed pipeline route. The offshore pipeline would be 1.5 miles (2.4 km) shorter, which would require about 20% less construction material (including the pipeline, cathodic bracelets, etc.) and an estimated 10-14 days less construction time. The resulting trench volume for this alternative would be 177,500 cy.

Facilities Construction

The surface area and the number/type of facilities located on the LDPI would remain the same as the Proposed Action.

Drilling Operations

This alternative would increase the length of all wellbores by about 3,300 ft, to an average length of approximately 17,200 ft (5243 m), as compared to an average wellbore length of approximately 13,900 ft (4237 m) for the Proposed Action.

Increased well length would require a larger drilling rig to access the reservoir due to the need for:

- Increased hydraulic horsepower (HP) of the rig (increased fuel consumption)
- Increased hole volume (increased drilling mud and cuttings)
- Increased torque capability
- Increased hookload capacity
- An additional casing string interval and higher grade casing to allow the longest wells to achieve the targets reliably

- A larger diameter blow out preventer (BOP) stack which requires several ft or more of additional height clearance below the rig floor. Increasing BOP bore size diameter typically requires increasing the size of the closing unit.
- Increased maintenance

Additionally, the extra casing string would require all uphole casing string diameters to be increased. The volume of rock cuttings and drilling fluid waste generated from these additional volumes and the additional thousands of feet in well length could necessitate an additional disposal well and a higher capacity grind and injection plant on the LDPI, or barging of excess materials onshore for disposal.

Adding an extra casing string in each well may also necessitate a reduction in the size of the production casing to allow drift clearance and proper cementing between strings. A reduction in the size of the production casing would require a reduction in the diameter of the production tubing. This would result in a significant drop in production rates, which would result in additional wells being required to produce an equivalent volume of oil in a similar time. The frictional forces of the additional well length would reduce per-well production rates, regardless of the tubing diameter.

Drilling time for this alternative would increase from about 45 days to 56 days per well, and fuel consumption during drilling would increase from approximately 7,500 gallons (28,390 L) per day (gpd) to 9,700 (36,718 L) gpd.

Production Operations and Decommissioning

Production operations and Decommissioning under Alternative 3B would remain the same as in the Proposed Action.

2.2.4.3. EPA Permitting

Under Alternative 3B, EPA would not have NPDES permitting authority and would not issue an NPDES permit. Discharges would occur in State waters and the Alaska Department of Environmental Conservation (ADEC) would be the permitting authority and the discharges would be subject to an Alaska Pollutant Discharge Elimination System (APDES) permit.

2.2.4.4. USACE Permitting

Under Alternative 3A, the following proposed activities would require a permit from USACE because they would impact WOUS. The following activities are subject to Section 404 of the Clean Water Act:

- Development of a 21 ac (8.5 ha) gravel mine site (discharge of fill into jurisdictional wetlands)
- Construction of the tie-in pad, totaling 0.7 ac (0.28 ha) (discharge of fill into jurisdictional wetlands)
- Construction of ice road crossing pad, totaling 0.15 ac (0.06 ha) (discharge of fill into jurisdictional wetlands)
- Construction of VSMs (footprints) to support the elevated onshore pipeline over 1.5 miles (2.4 km) , totaling 0.03 ac (0.12 ha) (discharge of fill into jurisdictional wetlands)
- Construction of the pipeline landfall trench, totaling 1.4 ac (0.57 ha) (discharge of fill into jurisdictional wetlands)
- Construction of the portion of pipeline located within the Territorial Seas, totaling 4.9 miles (7.9 km) and 35.6 ac (14.4 ha) (the discharge of fill below mean high tide in Navigable Waters (the Beaufort Sea))

The construction of the 4.9 miles (7.9 km) portion (35.6 ac (14.4 ha)) of pipeline within the Territorial Seas is subject to not only Section 404 of the Clean Water Act jurisdiction, but also to Section 10 of the Rivers and Harbors Act.

A Department of the Army permit under Section 10 of the Rivers and Harbors Act—as extended by section 4(f) of the Outer Continental Shelf Lands Act of 1953 as amended (43 U.S.C. 1333(e))—would also be required for the construction of the 24.5 ac (9.9 ha) artificial island and 1.3 miles (2.1 km) (9.5 ac (3.8 ha)) of the pipeline on the Outer Continental Shelf. This work would not be subject to Section 404 of the Clean Water Act.

Therefore, Alternative 3A would result in 23.28 ac (9.4 ha) of impacts subject to Section 404 only (onshore impacts), 35.6 ac (14.4 ha) subject to both Section 404 and Section 10 (Territorial Seas impacts), and 34 ac (13.8 ha) subject to Section 10 only (OCS impacts). An Individual Permit would be issued under Section 404 and Section 10 authorities.

Under Alternative 3B, the following proposed activities would require a permit from USACE because they would impact WOUS. The following activities are subject to Section 404 of the Clean Water Act:

- Development of a 21 ac (8.5 ha) gravel mine site (discharge of fill into jurisdictional wetlands)
- Construction of the tie-in pad, totaling 0.7 ac (0.28 ha) (discharge of fill into jurisdictional wetlands)
- Construction of ice road crossing pad, totaling 0.15 ac (0.06 ha) (discharge of fill into jurisdictional wetlands)
- Construction of VSMs (footprints) to support the elevated onshore pipeline over 1.5 miles (2.4 km) , totaling 0.03 ac (0.12 ha) (discharge of fill into jurisdictional wetlands)
- Construction of the pipeline landfall trench, totaling 1.4 ac (0.57 ha) (discharge of fill into jurisdictional wetlands)
- Construction of the portion of pipeline located within the Territorial Seas, totaling 4.1 miles (6.6 km) and 29.8 ac (12.1 ha) (the discharge of fill below mean high tide in Navigable Waters (the Beaufort Sea))
- Construction of the Alternate 3B proposed LDPI within the Territorial Seas, totaling 23.4 ac (9.5 ha), (the discharge of fill below mean high tide in Navigable Waters (the Beaufort Sea))

The construction of the 4.9 miles (7.9 km) portion (35.6 ac (14.4 ha)) of pipeline and the Alternate 3B proposed LDPI (23.4 ac (9.5 ha)) within the Territorial Seas is subject to not only Section 404 of the Clean Water Act jurisdiction, but also to Section 10 of the Rivers and Harbors Act.

Therefore, Alternative 3B would result in 23.28 ac (9.6 ha) of impacts subject to Section 404 only (onshore impacts), and 59 ac (23.9 ha) subject to both Section 404 and Section 10 (Territorial Seas impacts). An Individual Permit would be issued under Section 404 and Section 10 authorities.

2.2.5. Alternative 4 (Alternate Processing Locations)

This Alternative has 2 subalternatives. Alternative 4A would move the oil and gas processing facilities from the LDPI to the existing Endicott SDI facility. Alternative 4B would move oil and gas processing facilities from the LDPI to a new onshore facility. Both of these subalternatives would be located in areas of existing archaeological surveys.

Both subalternatives match the Proposed Action in that the LDPI would be constructed and house wells to access the reservoir, and a pipeline would still be necessary to transport fluid to shore. They differ from the Proposed Action in that fluid transported via pipeline from the LDPI would be an unprocessed solution of oil, gas, water, and other constituents (t termed “3-phase” fluid) as opposed

to processed oil. For a comparison of the components of Alternative 4A and 4B with the Proposed Action, see Tables 2.2.7 1 - 2.2.7 5.

These alternatives were developed as a result of scoping comments suggesting that onshore processing may minimize impacts to marine resources and subsistence harvest practices from on-island equipment noise and vibration.

2.2.5.1. Alternative 4A: Relocate Oil and Gas Processing to Endicott SDI

Under this alternative, processing would be carried out at the Endicott SDI facility. Drilling activities would remain on LDPI (Figure 2.2.5-1.)

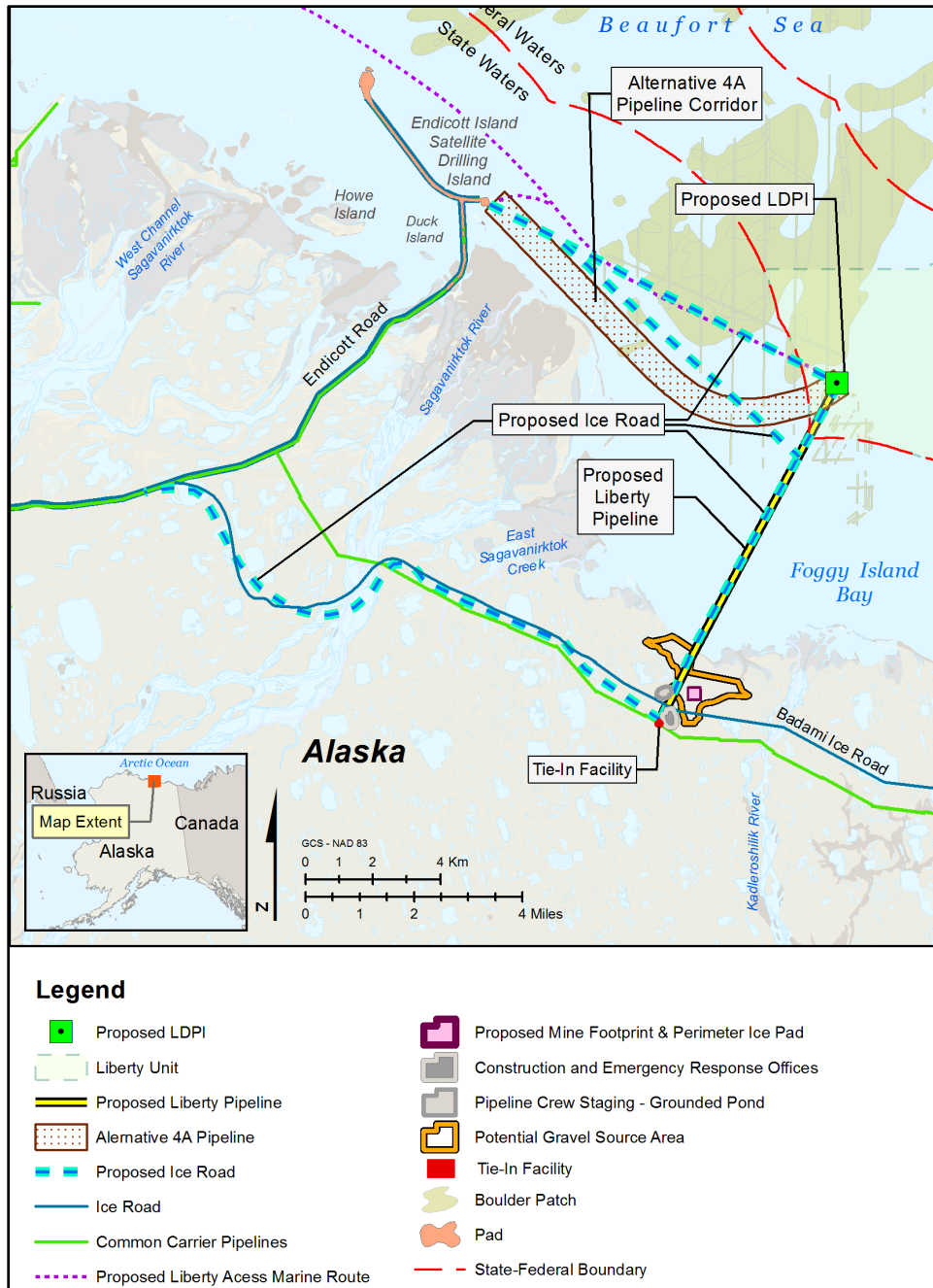

Figure 2.2.5-1. Alternative 4A: Endicott SDI Processing + Alternate Pipeline Route.

Winter & Summer Access

Ice road construction activities would remain the same under Alternative 4A as for the Proposed Action. The ice roads would run approximately 35 miles (56 km) in total. Summer access would involve the use of the same marine vessels as described in the Proposed Action.

Gravel Mine Site Development

In this alternative, the mine site would decrease to about 18 acres (7.3 ha) compared to the 21 acres (8.5 ha) described in the Proposed Action. About 853,000 cy would be extracted to support Alternative 4A compared to the less than 1,500,000 cy described in the Proposed Action. This site is a 13 mile (21 km) round trip from the proposed gravel mine site, which would require would require 8 trucks working for 56 days, using approximately 224,000 gallons (848,000 L) of fuel.

Island Construction

Relocating the oil and gas processing, produced water treatment, and seawater treatment facilities to Endicott SDI would reduce the work surface area of the LDPI to 5.4 ac (2.2 ha) (9.3 ac (3.8 ha) for the Proposed Action). The seabottom footprint would also decrease to about 17.2 ac (6.96 ha) (24 ac (7.1 ha) for the Proposed Action). The LDPI for this alternative would require approximately 540,000 cy of gravel to construct (compared to less than 950,000 cy). The decreased LDPI size would require roughly 18-20 days less to construct.

Pipeline Construction

In this alternative, the subsea pipeline bundle would be routed to the west of the LDPI to the Endicott SDI; from that point, existing pipelines would transport the oil into the TAPS. This alternative would increase the subsea pipeline length to 7.7 miles (12.4 km) from 5.6 miles (9 km) under the Proposed Action. For the 3-phase pipeline, materials (including the pipeline, cathodic bracelets, etc.) required would increase by approximately 50%.

This alternative would change the design of the pipeline bundle to include:

- A 14 inch (35.6 cm) diameter pipe-in-pipe 3-phase pipeline
- A 10 inch (25.4 cm) insulated and concrete coated seawater pipeline
- A 6 inch (15.2 cm) high pressure natural gas pipeline
- A shielded power cable
- A fiber-optic communications cable

These additions to the pipeline bundle would be necessary because natural gas and produced water would not be separated on-site, and would need to be transported back to LDPI after separation into single phases. This would increase the pipeline materials cost by approximately 250%. The offshore construction time would increase by 40-50 days for the additional welding required to assemble the pipelines. The pipeline trench depth and trench design would require additional engineering and calculations to determine the minimum depth of cover and strain demand of the pipeline due to thaw settlement. The resulting trench volume would be about 292,000 cy.

Facilities Construction

Endicott SDI was constructed in 1987 with a 25-30 year design life, meaning that the facility was designed to last until 2017 without tremendous changes or modifications. If Endicott SDI were to process Liberty fluids, the design life of this facility would have to be more than doubled, as the proposed LDPI also has a proposed design life of 25-30 years, and first production is not expected until a few years after 2017. Extensive work would have to occur at Endicott SDI to accomplish this increase in design life, particularly in the realm of engineering design and equipment fabrication and

installation. Although the Endicott SDI and Liberty reservoir fluids are similar, they are not the same, meaning that different processing methods (by means of additional or modified equipment) may be required to reach sales quality oil grade fluid, and that additional equipment would be necessary to simply accommodate the volume of fluids provided by the Liberty reservoir.

The additional equipment and processing load would also require 10-12 additional personnel at the facility. The expected operational cost (including engineering redesign, additional/modified equipment, general maintenance of an aging facility) of maintaining Endicott SDI for the design life of Liberty is estimated to be twice the cost to build and maintain the proposed LDPI.

Endicott SDI is the closest existing oil and gas processing facility to the Liberty reservoir. It is currently operated by HAK.

Drilling Operations

Drilling activities under Alternative 4A would be similar as those described for the Proposed Action. Additional decommissioning activities would occur on Endicott SDI.

Production Operations

Sales Oil Conditioning

Oil, gas, and water would be carried in a single pipeline from the LDPI Endicott SDI and on to Endicott for processing. The 3-phase fluid would be separated and treated at the existing Endicott SDI facility. Analyses have not been completed to know the effects of comingling the production fluids from Liberty and Endicott SDI, but for the purpose of this DEIS alternative it is assumed that comingling is unlikely to cause any significant issues because the crude oil from the Liberty oil pool is very similar to the Endicott oil pool.

Key changes from the Proposed Action:

- Equipment such as production modules, custody transfer metering, sale oil pumps, and oil storage tanks, would not be present on LDPI. Instead, additional equipment and facilities upgrades would be required at Endicott SDI to handle the additional flow from the Liberty reservoir.
- Booster pumps would need to be installed offshore to propel the 3-phase fluid to the Endicott SDI.
- Methane hydrate inhibition equipment on LDPI would need a larger volume capacity to prevent hydrate formation in the 3 phase line before reaching Endicott SDI. Hydrates form in pipelines from mixing of natural gas and water at low temperature and high pressures and can be a nuisance or danger if not treated effectively. Liberty's high CO₂ content and presence of H₂S may make it more susceptible to hydrate formation in a 3 phase stream. Depending on need and the inhibition methods deemed appropriate by the operator, the following may be necessary:
 - Larger capacity fuel-gas fired production heater(s) on LDPI and/or
 - Chemical treatment equipment and chemical pipeline (typically methanol) from SDI to LDPI or constant resupply of chemicals by barge.
- The 12 inch (30.5 cm) pipe-in-pipe sales oil pipeline would be changed to a 14 inch (35.6 cm) 3-phase pipe-in-pipe pipeline.

Gas Compression and Treatment

Currently, the Endicott SDI facility does not have the capacity to support additional produced gas from Liberty. The additional equipment and processing load would also require an additional 10 to 12 operators at the facility. The expected operational cost (including engineering redesign, additional/modified equipment, general maintenance of an aging facility) of maintaining Endicott SDI

for the design life of Liberty is estimated to be twice the cost to build and maintain the proposed LDPI.

Key changes from the Proposed Action:

Gas processing equipment that would be relocated to Endicott SDI:

- All gas compressor modules
- Vapor recovery module
- Gas dehydration unit, flare boom
- Flare and flare knock out vessel
- Associated metering
- A 6 inch (15.2 cm) high pressure natural gas pipeline would be added to the pipeline bundle

Processed natural gas from the Liberty reservoir would be used to provide reinjection gas for pressure maintenance of the reservoir. Natural gas is also used for gas lift operations, which increase and maintain maximum economic production and depletion rates.

After processing at Endicott, the produced gas would be compressed in multiple stages and transported through a high pressure pipeline back to the LDPI to be used as fuel gas, wellbore lift gas, and reservoir injection gas. The high pressure pipeline would transport approximately 120 million standard cubic feet per day (MMscfd) of natural gas at approximately 5,000 pounds per square inch gauge pressure (psig) to the LDPI. As a result of commingled 3-phase production at SDI, some processed Liberty natural gas would be used for fuel gas and reinjection in wells at Endicott and Endicott SDI and vice versa. Any Natural Gas Liquids (NGLs) formed in processing at Endicott would be sold as oil through the Badami pipeline as specified vapor pressure limits allow. Remaining NGLs are blended to become a miscible injectant that is used in Miscible Water-Alternating-Gas (MWAG) enhanced recovery operations at Endicott, Endicott SDI, and LDPI.

Produced Water Treatment

Produced water equipment, including water filtration modules, produced water pumps, and a water storage tank would be relocated at Endicott. The produced water would be treated, combined with treated seawater, and pumped back for reinjection at LDPI to enhance oil recovery. As a result of commingled 3-phase production at SDI, some Liberty produced water would be used for reinjection in wells at Endicott and Endicott SDI and vice versa.

Power Generation

For this alternative, power for the offshore LDPI facility would be generated at Endicott SDI. Existing facilities on Endicott SDI would require upgrades and/or additional generators for the increased demand for the onshore and offshore power. Natural gas from the comingled (Endicott and Liberty) production fluid would be used to generate power for both Endicott SDI and Liberty facilities, including drilling rigs and other equipment.

Key changes from the Proposed Action:

- Power generation equipment to be relocated to Endicott SDI would include power generation units, switchgear modules, and associated cable trays.
- A shielded power cable would be added to the pipeline bundle.

Seawater Treatment

The seawater treatment would be located at Endicott SDI. The seawater treatment plant at Endicott SDI is not currently in service. This alternative would require significant upgrades (more modules and associated piping to process the additional volume of seawater) to bring the Endicott SDI facility

online. The estimated cost of this equipment upgrade is equivalent to the estimated cost for new equipment on LDPI.

In this alternative, treated seawater and produced water would be pumped from Endicott SDI to the LDPI for injection into the Liberty reservoir. The Proposed Action states that about 80,000 bbl per day of seawater and produced water would be injected into the reservoir for enhanced oil recovery, which is assumed to be the same amount required in this alternative.

Key changes from the Proposed Action:

- One 10 inch insulated and concrete coated seawater and produced water pipeline would be added to the pipeline bundle.
- Additional pumps would be required to pipe water from Endicott to Liberty Island.

Decommissioning

Decommissioning activities under Alternative 4A would be similar to those described for the Proposed Action.

2.2.5.2. Alternative 4B: Relocate Oil and Gas Processing to a New Onshore Facility

Under this alternative, a new onshore oil and gas processing facility to be constructed near the Badami pipeline tie-in point (Figure 2.2.5-2)

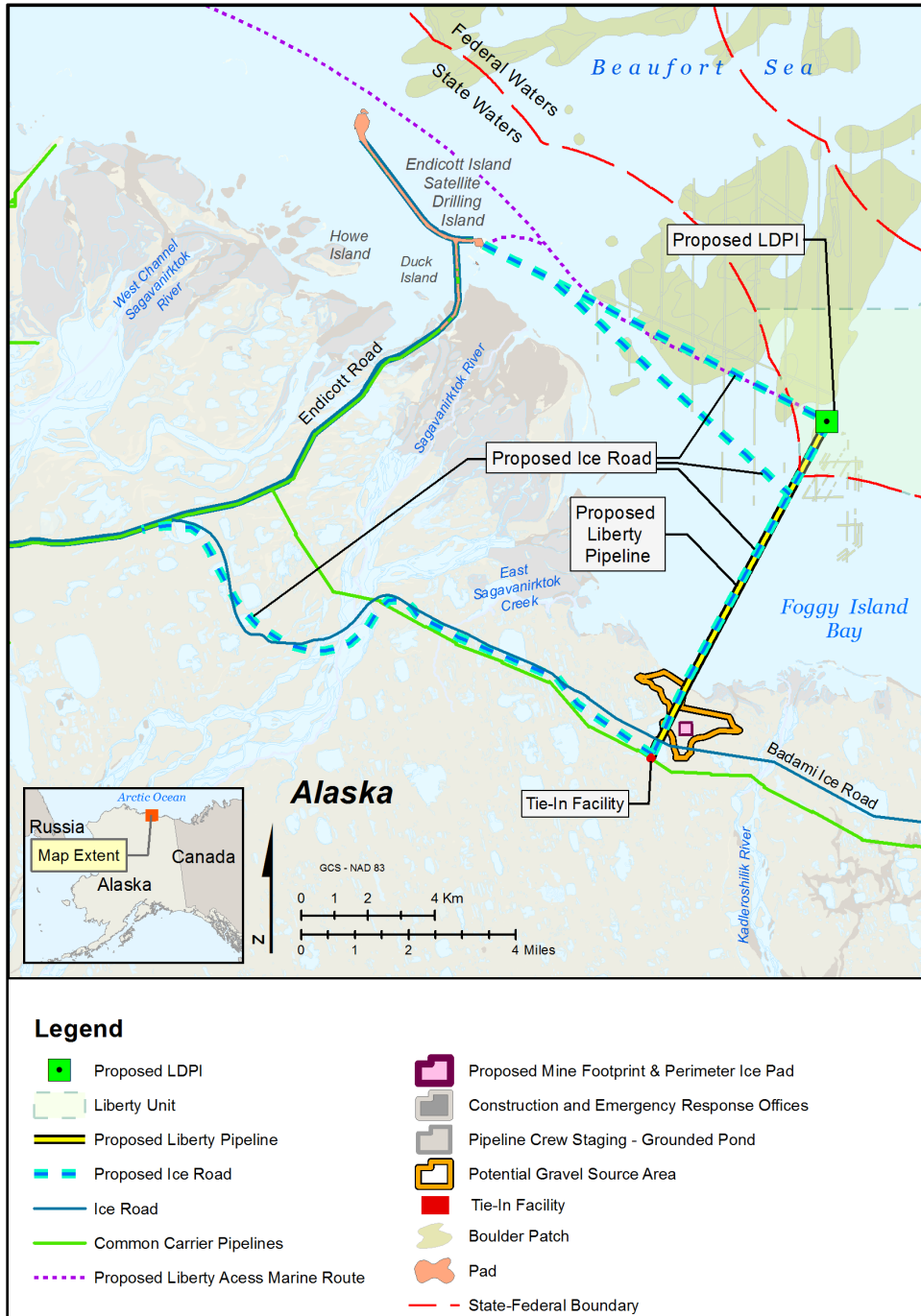

Figure 2.2.5-2. Alternative 4B: Onshore Processing

Winter & Summer Access

Ice road construction activities would remain the same under Alternative 4B as for the Proposed Action. Summer access would involve the use of the same marine vessels as described in the

Proposed Action and a gravel road would be constructed along the Badami pipeline corridor to reach this facility.

A permanent gravel road would be constructed to support transportation between the new onshore processing facility. This gravel road would be about 52 feet (15.8 m) wide and nearly 9 miles (15.5 km) long, requiring about 540,000 cy of gravel.

Gravel Mine Site Development

The combined gravel requirements for the reduced LDPI and additional onshore Liberty Processing Pad would be about 1,604,000 cy. About 1,064,000 cy would be extracted from a 17 ac mine site (West Kadleroshilik Mine Site #1) and about 540,000 cy from an approximately 13 ac expansion the Duck Island Mine Site.

Island Construction

Relocating the oil and gas processing and produced water treatment to an onshore pad would reduce the required working surface area of the proposed LDPI. Under Alternative 4B, the working surface area would be reduced from 9.3 ac for Proposed Action to 6.1 ac. The disturbance to the seafloor would be reduced from 24 ac for the Proposed Action to 18.4 ac. This island would require up to 700,000 cy of gravel to construct, as compared to less than 950,000 cy for the Proposed Action. The smaller LDPI would require 15-20 days less time to construct.

The additional onshore Liberty Processing Pad would have 3.9 ac of working surface area. The estimated gravel required for construction is 44,800 cy. This onshore Liberty Pad would require about 10-12 additional days for construction

Pipeline Construction

In this alternative, the subsea pipeline bundle would maintain the route of the Proposed Action.

This alternative would change the design of the pipeline bundle to include:

- A 14" pipe-in-pipe 3-phase pipeline
- A 6" high pressure natural gas pipeline
- A shielded power cable
- A fiber-optic communications cable
- A pipeline to return produced water to LDPI for reinjection
- An enlarged outer pipe to house the 14" inner pipe

These changes to the pipeline bundle would increase pipeline materials cost by roughly 50%. The offshore construction time would increase by 10-15 days for the additional welding required to assemble the pipelines. The trench depth and design for this alternative would require engineering and calculations to determine the minimum depth of cover and strain demand of the pipeline due to thaw settlement.

Facilities Construction

In this alternative, oil and gas processing would be conducted at a new facility near the Badami Sales Oil Pipeline tie-in point. A new production pad would be constructed to host the processing equipment relocated from the LDPI. This new pad would require an estimated 16-20 operations personnel in addition to the required 8-12 operators offshore.

Drilling Operations

Drilling activities under Alternative 4B would be similar to those described for the Proposed Action.

Production Operations

Sales Oil Conditioning

In this alternative, 3-phase production fluid would be comingled into a single pipeline for processing onshore. After transport to the onshore facility, the 3-phase fluid would be separated and treated in the same manner as described in the Proposed Action. Sales quality oil would then be metered and transported via pipeline to the Badami Sales Oil Pipeline tie-in pad where it would mix with oil from Badami and Point Thomson before entering the TAPS.

Key changes from the Proposed Action:

- Produced fluid equipment to be located on shore includes production modules, custody transfer metering, sale oil pumps, and oil storage tanks.
- The 12” pipe-in-pipe sales oil pipeline would be changed to a 14” 3-phase pipe-in-pipe pipeline.

Gas Compression & Treatment

In this alternative, the produced gas would be compressed in multiple stages at the onshore facility and transported back to the offshore facility for fuel gas, wellbore lift gas, and reservoir injection gas. The high pressure pipeline would transport approximately 120 MMscfd of natural gas at approximately 5,000 psig to the LDPI. Processed natural gas from the Liberty reservoir would provide reinjection gas for pressure maintenance of the reservoir. This pressure maintenance is necessary for supporting reservoir management efforts in order to maximize the total economic recovery of available hydrocarbon liquids. Gas lift operations also require the use of natural gas to increase and maintain maximum economic production and depletion rates.

Key changes from the Proposed Action:

- Gas processing equipment to be relocated onshore: all gas compressor modules, vapor recovery module, gas dehydration unit, flare boom, flare knock out pot and associate metering.
- A 6” high pressure natural gas pipeline would be added to the pipeline bundle.

Produced Water Treatment

The produced water would be treated and prepared for reinjection at LDPI.

Key changes from the Proposed Action:

- Produced water equipment to be relocated onshore: water filtration modules, produced water pumps, and a water storage tank.

Power Generation

Power for the LDPI and the new onshore Liberty Processing Pad would be generated onshore. Natural gas from the reservoir production stream would be used to generate power for the offshore and onshore facilities, including drilling rigs and other equipment.

Key changes from the Proposed Action:

- Additional power requirements would result from duplicate systems for LDPI and the onshore Liberty Pad processing.

Seawater Treatment

The seawater treatment plant would be located onshore at or near the new production processing plant. In this alternative, treated seawater and produced water would be pumped from shore to the LDPI for injection into the Liberty reservoir. The Proposed Action states that approximately 80,000

bbl per day of seawater and produced water would be injected into the reservoir for enhanced oil recovery, which is assumed to be the same amount required in this alternative.

Key changes from the Proposed Action:

- One 10” insulated and concrete coated seawater and produced water pipeline would be added to the pipeline bundle.
- One 12” seawater intake pipeline would extend from the treatment plant to shore where it would connect to a seawater intake facility.
- Additional pumps would be required to pipe water from shore to Liberty Island.

Decommissioning

Decommissioning activities under Alternative 4B would be the similar as those described for the Proposed Action. Additional decommissioning activities would occur at the onshore processing facility.

2.2.5.1. EPA Permitting

Under Alternative 4, certain discharges would be transported to the Endicott Satellite Drilling Island (Alternative 4A) or a new onshore production facility (Alternative 4B), both of which are located in, or would discharge to state waters. EPA’s permitting requirements under Alternative 4a would include providing NPDES permit coverage for the following waste streams discharged from the LDPI into Federal waters:

- Sanitary and domestic wastewater (Outfalls 001a)
- Potable water treatment reject (Outfall 001b)
- Construction dewatering (Outfall 003)
- Secondary containment dewatering (Outfall 004)

All other waste streams would be discharged to state waters and would require APDES coverage from ADEC.

2.2.5.2. USACE Permitting

Under Alternative 4A, the following proposed activities would require a permit from USACE because they would impact WOUS. The following activities are subject to Section 404 of the Clean Water Act:

- Development of a 18 ac gravel mine site (discharge of fill into jurisdictional wetlands)
- Construction of the portion of pipeline located within the Territorial Seas, totaling 7.1 miles and 51.6 ac (the discharge of fill below mean high tide in Navigable Waters (the Beaufort Sea))

The construction of the 7.1 miles (51.6 ac) of pipeline within the Territorial Seas is subject to not only Section 404 of the Clean Water Act jurisdiction, but also to Section 10 of the Rivers and Harbors Act.

A Department of the Army permit under Section 10 of the Rivers and Harbors Act (as extended by section 4(f) of the Outer Continental Shelf Lands Act of 1953 as amended (43 U.S.C. 1333(e))) would also be required for the construction of the 17.2 ac artificial island and 0.6 miles (4.4 ac) of the pipeline on the Outer Continental Shelf. This work would not be subject to Section 404 of the Clean Water Act.

Therefore, Alternative 4A would result in 18 ac of impacts subject to Section 404 only (onshore impacts), 51.6 ac subject to both Section 404 and Section 10 (Territorial Seas impacts), and 21.6 ac

subject to Section 10 only (OCS impacts). An Individual Permit would be issued under Section 404 and Section 10 authorities.

Under Alternative 4B, the following proposed activities would require a permit from the Corps because they would impact WOUS. The following activities are subject to Section 404 of the Clean Water Act:

- Development of two gravel mine sites, totaling 30 ac (discharge of fill into jurisdictional wetlands)
- Construction of an onshore facility, totaling 3.9 ac (discharge of fill into jurisdictional wetlands)
- Construction of a gravel road, totaling 57 ac (discharge of fill into jurisdictional wetlands)
- Construction of ice road crossing pad, totaling 0.15 ac (discharge of fill into jurisdictional wetlands)
- Construction of VSMS (footprints) to support the elevated onshore pipeline over 1.5 miles, totaling 0.03 ac (discharge of fill into jurisdictional wetlands)
- Construction of the pipeline landfall trench, totaling 1.4 ac (discharge of fill into jurisdictional wetlands)
- Construction of the portion of pipeline located within the Territorial Seas, totaling 4.5 miles and 33 ac (the discharge of fill below mean high tide in Navigable Waters (the Beaufort Sea))

The construction of the 4.5 miles portion (33 ac) of pipeline within the Territorial Seas is subject to not only Section 404 of the Clean Water Act jurisdiction, but also to Section 10 of the Rivers and Harbors Act.

A Department of the Army permit under Section 10 of the Rivers and Harbors Act (as extended by section 4(f) of the Outer Continental Shelf Lands Act of 1953 as amended (43 U.S.C. 1333(e))) would also be required for the construction of the 18.4 ac artificial island and 1.1 miles (8 ac) of the pipeline on the Outer Continental Shelf. This work would not be subject to Section 404 of the Clean Water Act.

Therefore, Alternative 4B would result in 92.5 ac of impacts subject to Section 404 only (onshore impacts), 33 ac subject to both Section 404 and Section 10 (Territorial Seas impacts), and 26.4 ac subject to Section 10 only (OCS impacts). An Individual Permit would be issued under Section 404 and Section 10 authorities.

2.2.6. Alternative 5 (Alternate Gravel Sources)

Alternatives 5A, 5B, and 5C consider three different proposed gravel mine site locations. (Figures 2.2.6-1 and 2.2.6-2)

These subalternatives were developed in response to scoping comments suggesting BOEM analyze an alternate location for the proposed West Kadleroshilik River Mine Site #1 to minimize impacts to migratory birds, wetlands, fish used for subsistence purposes, and other resources. BOEM conducted a thorough review of existing technical and survey information and based on this review identified 3 reasonable alternate locations.

For a comparison of the components of Alternative 5A, 5B, and 5C with the Proposed Action, see Tables 2.2.7-1 through 2.2.7-5.

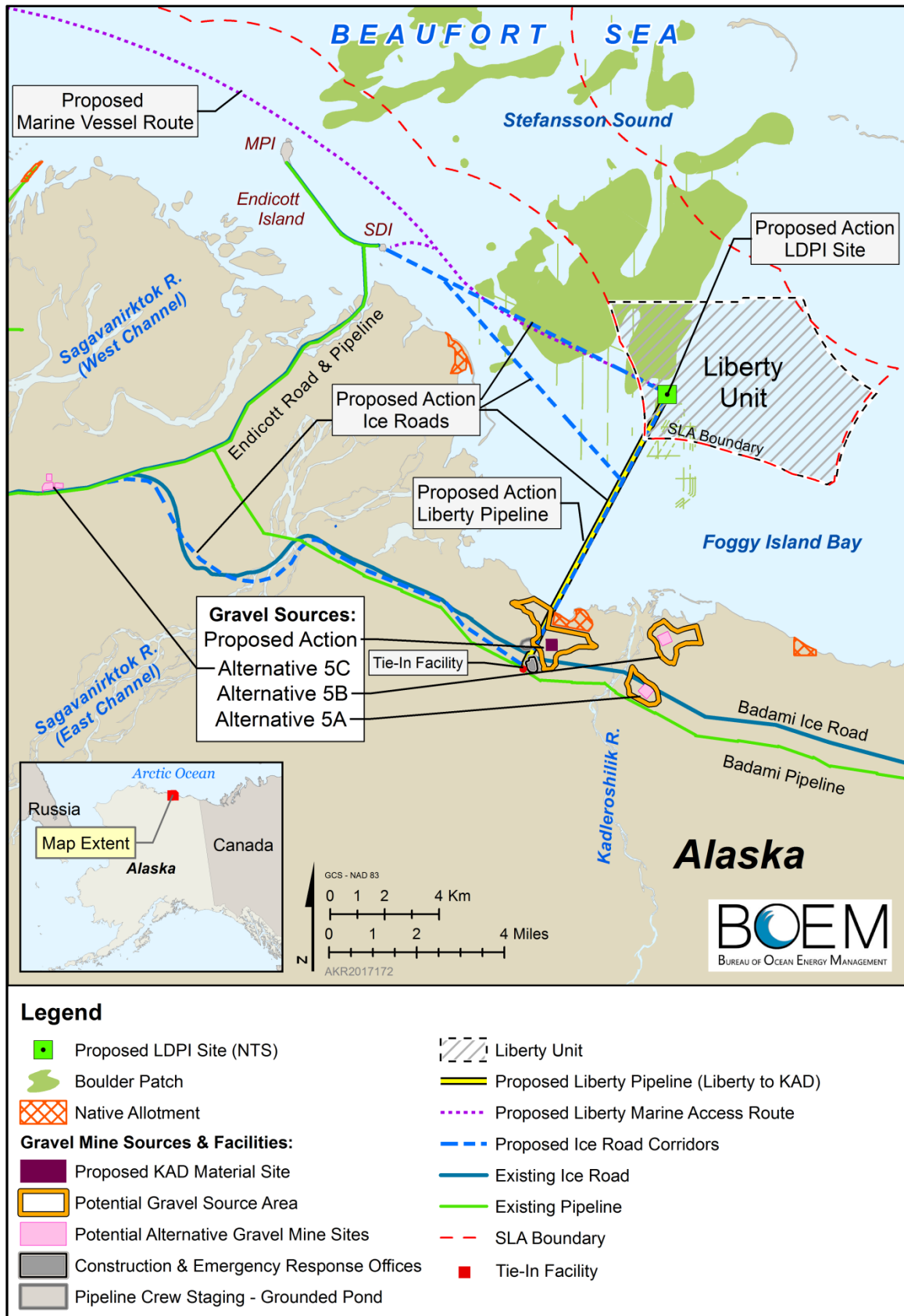

Figure 2.2.6-1 Alternative 5: Alternate Mine Site Locations, Overview

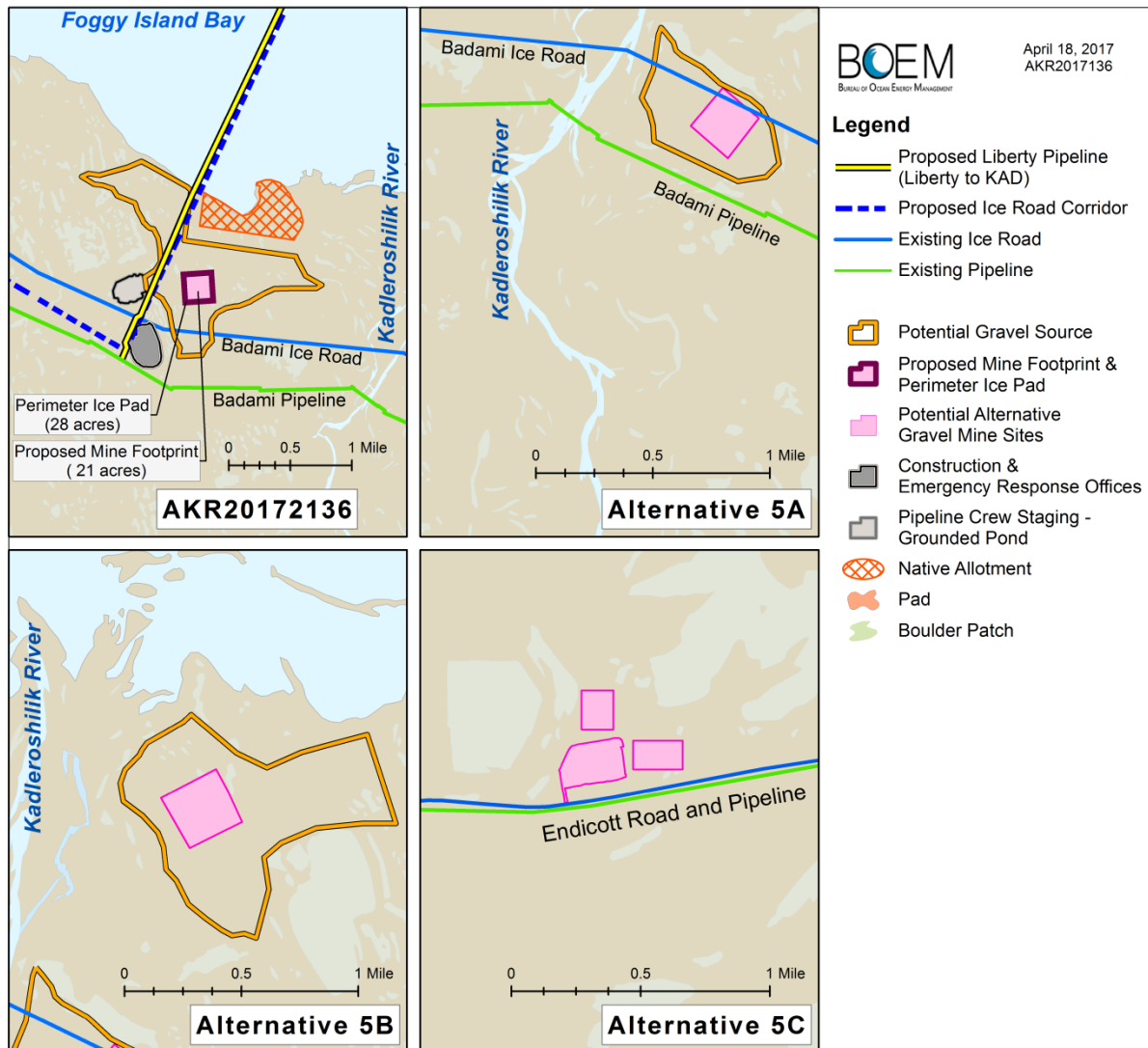

Figure 2.2.6-2. Alternative 5: Alternate Mine Site Locations, Detail

2.2.6.1. Alternative 5A: East Kadleroshilik River Mine Site #2

Winter & Summer Access

Ice road construction activities would remain the same under Alternative 5A as for the Proposed Action, though the location and length would differ. Summer access would involve the use of the same marine vessels as described in the Proposed Action.

Gravel Mine Site Development

This site lies about 2 miles inland from the coast on an isolated area of high ground immediately east of the Kadleroshilik River. It is outside of the active floodplain. This alternative would require an ice road (not included in the Proposed Action) with a river crossing.

There has not been geotechnical information collected for this specific area. However, nearby areas have shown sandy gravel with fines content of 12%, ranging from 15 ft to 40 ft in the subsurface; the first 15 ft is considered overburden.

This location is a 13 mile round trip from the LDPI. This alternative would require 14 trucks working over a period of 76 days, using 380,000 gallons of fuel.

Island, Pipeline, and Facilities Construction, Drilling and Production Operations, and Decommissioning

These activities would remain the same under Alternative 5A as for the Proposed Action.

2.2.6.2. Alternative 5B: East Kadleroshilik River Mine Site #3

Winter & Summer Access

Ice road construction activities would remain the same under Alternative 5B as for the Proposed Action, though the location and length would differ. The ice roads would run approximately 34 miles in total. Summer access would involve the use of the same marine vessels as described in the Proposed Action.

Gravel Mine Site Development

This site is near the coast (approximately 0.5 miles), is of adequate elevation to avoid seawater inundation, but is at greater risk for coastal erosion. This alternative would require an additional ice road (not included in the Proposed Action) with a river crossing.

There has not been geotechnical information collected for this specific area. However, nearby areas have shown sandy gravel with fines content of 12%, ranging from 15 ft to 40 ft in the subsurface; the first 15 ft is considered overburden.

This location is a 13 mile round trip from the LDPI. This alternative would require 14 trucks working over a period of 76 days, using 380,000 gallons of fuel.

Island, Pipeline, and Facilities Construction, Drilling and Production Operations, and Decommissioning

These activities would remain the same under Alternative 5B as for the Proposed Action.

2.2.6.3. Alternative 5C: Duck Island Mine Site

Winter & Summer Access

Ice road construction activities would remain the same under Alternative 5C as for the Proposed Action, though the location and length would differ. Summer access would involve the use of the same marine vessels as described in the Proposed Action.

Gravel Mine Site Development

The existing Duck Island Mine Site is currently flooded and not considered rehabilitated. This site is a 42 mile round trip from the LDPI. The Duck Island Mine Site is currently not large enough to provide enough gravel to build the LDPI and would have to be expanded by about 23 ac. Historical, adjacent geotechnical surveys have shown gravelly-sand and sandy gravel to a nominal depth of 50 ft subsurface; the first 8 ft is considered overburden.

The depth of this site varies from the Proposed Action, thus the difference in acreage.

This Alternative would require 22 trucks working for 135 days, (likely over 2 seasons) to haul enough gravel to complete the LDPI. This would consume approximately 1,147,500 gallons of diesel fuel.

Island, Pipeline, and Facilities Construction, Drilling and Production Operations, and Decommissioning

These activities would remain the same under Alternative 5C as for the Proposed Action.

2.2.6.4. EPA Permitting

EPA's permitting requirements under Alternative 5 are identical to the Proposed Action.

2.2.6.5. USACE Permitting

Both Alternative 5A and 5B would generally result in about 23.3 ac of impacts subject to Section 404 only (onshore impacts to WOUS), 33 ac subject to both Section 404 and Section 10 (Territorial Seas impacts), and 32 ac subject to Section 10 only (OCS impacts). An Individual Permit would be issued under Section 404 and Section 10 authorities.

Under Alternative 5C, the following proposed activities would require a permit from USACE because they would impact WOUS. The following activities are subject to Section 404 of the Clean Water Act:

- Development of a 23 ac gravel mine site (discharge of fill into jurisdictional wetlands)
- Construction of the tie-in pad, totaling 0.7 ac (discharge of fill into jurisdictional wetlands)
- Construction of ice road crossing pad, totaling 0.15 ac (discharge of fill into jurisdictional wetlands)
- Construction of VSMS (footprints) to support the elevated onshore pipeline over 1.5 miles, totaling 0.03 ac (discharge of fill into jurisdictional wetlands)
- Construction of the pipeline landfall trench, totaling 1.4 ac (discharge of fill into jurisdictional wetlands)
- Construction of the portion of pipeline located within the Territorial Seas, totaling 4.5 miles and 33 ac (the discharge of fill below mean high tide in Navigable Waters (the Beaufort Sea))

The construction of the 4.5 mile portion (33 ac) of pipeline within the Territorial Seas is subject to not only Section 404 of the Clean Water Act jurisdiction, but also to Section 10 of the Rivers and Harbors Act.

A Department of the Army permit under Section 10 of the Rivers and Harbors Act (as extended by section 4(f) of the Outer Continental Shelf Lands Act of 1953 as amended (43 U.S.C. 1333(e))) would also be required for the construction of the 24 ac artificial island and 1.1 miles (8 ac) of the pipeline on the Outer Continental Shelf. This work would not be subject to Section 404 of the Clean Water Act.

Therefore, Alternative 5C would result in 25.3 ac of impacts subject to Section 404 only (onshore impacts), 33 ac subject to both Section 404 and Section 10 (Territorial Seas impacts), and 32 ac subject to Section 10 only (OCS impacts). An Individual Permit would be issued under Section 404 and Section 10 authorities.

2.2.7. Alternative Comparison Tables

Table 2.2.7-1. Alternatives Comparison Table, Onshore Activities

Alternatives	Ice Roads	Gravel Mine	Mining Truck Trips & Fuel Use (approximate)	Onshore Gravel Pads and Roads	Onshore Pipeline (miles) / VSMs (ac)
Alternative 1 (Proposed Action)	Annual Ice Road: 1 Construction Ice Roads: 3	Ac: 21 Depth: 42 – 60 ft Site: East Kadleroshilik Mine Site #1 Material Volume: <1,500,000 cy	Trucks: 14 Days: 76 Fuel use (gal): 380,000 Trip Distance (mi): 13	Ice Road Crossing: 1,500 cy (.15 ac) Tie-In Pad: 3,500 cy (.70 ac) Pipeline Landfall: 5,000 cy (1.4 ac)	1.5 / 0.03
Alternative 2 (No Action)	Not Applicable	Not Applicable	Not Applicable	Not Applicable	Not Applicable
Alternative 3A (Relocate LDPI Approximately 1 Mile to the East)	Annual Ice Road: 1 Construction Ice Roads: 3 Ice roads change length & course.	Ac: 21 Depth: 46 – 64 ft Site: East Kadleroshilik Mine Site #1 Material Volume: 1,322,000 cy	Trucks: 14 Days: 82 Fuel use (gal): 410,000 Trip Distance (mi): 13	Ice Road Crossing: 1,500 cy (.15 ac) Tie-In Pad: 3,500 cy (.70 ac) Pipeline Landfall: 5,000 cy (1.4 ac)	Same as Alternative 1
Alternative 3B (Relocate LDPI approximately 1.5 miles to the southwest)	Annual Ice Road: 1 Construction Ice Roads: 3 Ice roads change length & course.	Ac: 21 Depth: 38 – 56 ft Site: East Kadleroshilik Mine Site #1 Material Volume: 1,178,000 cy	Trucks: 14 Days: 62 Fuel use (gal): 310,000 Trip Distance (mi): 10	Ice Road Crossing: 1,500 cy (.15 ac) Tie-In Pad: 3,500 cy (.70 ac) Pipeline Landfall: 5,000 cy (1.4 ac)	Same as Alternative 1
Alternative 4A (Relocate Oil and Gas Processing to Endicott SDI)	Annual Ice Road: 1 Construction Ice Roads: 3 Ice roads change length & course.	Ac: 18 Depth: 42 – 60 ft Site: East Kadleroshilik Mine Site #1 Material Volume: 853,000 cy	Trucks: 8 Days: 56 Fuel use (gal): 224,000 Trip Distance (mi): 13	None	None
Alternative 4B (Relocate Oil and Gas Processing to a New Onshore Facility)	Annual Ice Road: 1 Construction Ice Roads: 3 Ice roads change length & course.	Ac: 17 Depth: 42 – 60 ft Site: East Kadleroshilik Mine Site #1 Material Volume: 1,064,000 cy <i>and</i> Ac: 13 Depth: 42 – 60 ft Site: Duck Island Mine Site Material Volume: 540,000 cy	Trucks: 20 Days: 96 Fuel use (gal): 624,000 Trip Distance (mi): 12	Onshore Facility: 44,800 cy (3.9 ac) Ice Road Crossing: 1,500 cy (.15 ac) Pipeline Landfall: 5,000 cy (1.4 ac) Gravel Road: 540,000 cy (57 ac)	Same as Alternative 1
Alternative 5A (East Kadleroshilik River Mine Site #2)	Annual Ice Road: 1 Construction Ice Roads: 3 Ice roads change length & course.	Ac: 21 Depth: 42 – 60 ft Site: East Kadleroshilik Mine Site #2 Material Volume: <1,500,000 cy	Trucks: 14 Days: 76 Fuel use (gal): 380,000 Trip Distance (mi): 13	Ice Road Crossing: 1,500 cy (.15 ac) Tie-In Pad: 3,500 cy (.70 ac) Pipeline Landfall: 5,000 cy (1.4 ac)	Same as Alternative 1
Alternative 5B (East Kadleroshilik River Mine Site #3)	Annual Ice Road: 1 Construction Ice Roads: 3 Ice roads change length & course.	Ac: 21 Depth: 42 – 60 ft Site: East Kadleroshilik Mine Site #3 Material Volume: <1,500,000 cy	Trucks: 14 Days: 76 Fuel use (gal): 380,000 Trip Distance (mi): 13	Ice Road Crossing: 1,500 cy (.15 ac) Tie-In Pad: 3,500 cy (.70 ac) Pipeline Landfall: 5,000 cy (1.4 ac)	Same as Alternative 1
Alternative 5C (Duck Island Mine Site)	Annual Ice Road: 2 Construction Ice Roads: 3 Ice roads change length & course. Mining would require 2 seasons at minimum.	Ac: 23 Depth: 42 – 60 ft Site: Duck Island Mine Site Material Volume: <1,500,000 cy	Trucks: 22 Days: 135 Fuel use (gal): 1,147,500 Trip Distance (mi): 42	Ice Road Crossing: 1,500 cy (.15 ac) Tie-In Pad: 3,500 cy (.70 ac) Pipeline Landfall: 5,000 cy (1.4 ac)	Same as Alternative 1

Table 2.2.7-2. Alternatives Comparison Table, Offshore Activities.

Alternatives	Island (LDPI)	Facilities & Systems (on island)	Pipeline	Pipeline, Territorial Seas (miles)(ac)	Pipeline, OCS (miles)(ac)
Alternative 1 (Proposed Action)	Surface (ac): 9.3 Subsea (ac): 24 Water Depth (ft): 19 Material Volume: <1,500,000 cy (~950,000 cy)	Processing facilities; Produced water treatment; Seawater treatment; Power generation; Communications facilities; Living quarters; Warehouse/Shop space; Vehicle Storage; General Storage Space; Heavy Equipment Storage; Helipad; Process Controls room; Bulk fluid storage; Fuel gas system; Instrument and utility air system; Chemical Injection Facilities; Pollution Prevention Equipment; Process heat recovery system and, Storage tanks	Offshore (mi): 5.6 Offshore (depth, ft): 9 - 11 Onshore (mi): 1.5 Total length (mi): 7.1 Design: 16-inch outer pipe, 12-inch inner pipe, 4-inch utility pipe and fiber optic cable	4.5 (33)	1.1 (8)
Alternative 2 (No Action)	Not Applicable	Not Applicable	Not Applicable	Not Applicable	Not Applicable
Alternative 3A (Relocate LDPI Approximately 1 Mile to the East)	Surface (ac): 9.3 Subsea (ac): 24.5 Water Depth (ft): 21 Material Volume: 999,000 cy	Same as Alternative 1	Offshore (mi): 6.2 Onshore (mi): 1.5 Total length (mi): 7.7 Design: 16-inch outer pipe, 12-inch inner pipe, 4-inch utility pipe and fiber optic cable Pipeline buried about 2 ft deeper.	4.9 (35.6)	1.3 (9.5)
Alternative 3B (Relocate LDPI approximately 1.5 miles to the southwest)	Surface (ac): 9.3 Subsea (ac): 23.4 Water Depth (ft): 17 Material Volume: 854,700 cy	Same as Alternative 1	Offshore (mi): 4.1 Onshore (mi): 1.5 Total length (mi): 5.6 Design: 16-inch outer pipe, 12-inch inner pipe, 4-inch utility pipe and fiber optic cable	4.1 (29.8)	0 (0)
Alternative 4A (Relocate Oil and Gas Processing to Endicott SDI)	Surface (ac): 5.4 Subsea (ac): 17.2 Water Depth (ft): 19 Material Volume:540,000 cy	Power generation; Communications facilities; Living quarters; Warehouse/Shop space; Vehicle Storage; General Storage Space; Heavy Equipment Storage; Helipad; Process Controls room; Bulk fluid storage; Fuel gas system; Instrument and utility air system; Chemical Injection Facilities; Pollution Prevention Equipment; Process heat recovery system and, Storage tanks	Offshore (mi): 7.7 Onshore (mi): 1.5 Total length (mi): 9.2 Design: 14-inch outer pipe, 10-inch seawater pipeline, 6-inch natural gas pipeline, power cable and fiber optic cable	7.1 (51.6)	0.6 (4.4)
Alternative 4B (Relocate Oil and Gas Processing to a New Onshore Facility)	Surface (ac): 6.1 Subsea (ac): 18.4 Water Depth (ft): 19 Material Volume: 700,000 cy	<i>ON ISLAND:</i> <i>ONSHORE:</i>	Offshore (mi): 5.6 Onshore (mi): 1.5 Total length (mi): 5.6 Design: 16-inch outer pipe, 14-inch inner pipe, 6-inch natural gas pipeline, #-inch produced water pipeline, power cable and fiber optic cable	Same as Alternative 1	Same as Alternative 1
Alternative 5A (East Kadleroshilik River Mine Site #2)	Same as Alternative 1	Same as Alternative 1	Same as Alternative 1	Same as Alternative 1	Same as Alternative 1
Alternative 5B (East Kadleroshilik River Mine Site #3)	Same as Alternative 1	Same as Alternative 1	Same as Alternative 1	Same as Alternative 1	Same as Alternative 1
Alternative 5C (Duck Island Mine Site)	Same as Alternative 1	Same as Alternative 1	Same as Alternative 1	Same as Alternative 1	Same as Alternative 1

Table 2.2.7-3. Alternative Comparison Table, Operations and Decommissioning

Alternatives	Drilling Operations	Production Operations	Decommissioning
Alternative 1 (Proposed Action)	Producer Wells: 5-8 Injection Wells (water/gas): 4-6 Disposal Wells: 2 disposal wells Average Well Length (ft): 13,900	Routine Production Operations; Routine Equipment Maintenance; Major Overhauls, Major Inspections; Unscheduled Equipment Maintenance; Plant Turnarounds	Project Life (years): 15 - 20 Pipeline: Cleaned, plugged and left in place. Island: Protective covering removed, left to erode
Alternative 2 (No Action)	Not Applicable	Not Applicable	Not Applicable
Alternative 3A (Relocate LDPI Approximately 1 Mile to the East)	Producer Wells: 5-8 Injection Wells (water/gas): 4-6 Disposal Wells: 2 disposal wells Average Well Length (ft): 13,500	Same as Alternative 1	Same as Alternative 1
Alternative 3B (Relocate LDPI approximately 1.5 miles to the southwest)	Producer Wells: 5-8 Injection Wells (water/gas): 4-6 Disposal Wells: 2 disposal wells Average Well Length (ft): 17,200	Same as Alternative 1	Same as Alternative 1
Alternative 4A (Relocate Oil and Gas Processing to Endicott SDI)	Same as Alternative 1	Routine Production Operations; Routine Equipment Maintenance; Major Overhauls, Major Inspections; Unscheduled Equipment Maintenance; Plant Turnarounds	Additional decommissioning would occur on Endicott SDI
Alternative 4B (Relocate Oil and Gas Processing to a New Onshore Facility)	Same as Alternative 1	Routine Production Operations; Routine Equipment Maintenance; Major Overhauls, Major Inspections; Unscheduled Equipment Maintenance; Plant Turnarounds	Additional decommissioning would occur at new onshore facility
Alternative 5A (East Kadleroshilik River Mine Site #2)	Same as Alternative 1	Same as Alternative 1	Same as Alternative 1
Alternative 5B (East Kadleroshilik River Mine Site #3)	Same as Alternative 1	Same as Alternative 1	Same as Alternative 1
Alternative 5C (Duck Island Mine Site)	Same as Alternative 1	Same as Alternative 1	Same as Alternative 1

Notes: Alternative 3B:1) Substantially increased drilling difficulty 2) Increased fuel use 3) Increase cuttings 4) Increased well maintenance issues

Table 2.2.7-4. Alternatives Comparison Table, Permitting Summaries.

Alternatives	USACE Impacts & Permitting ¹	EPA Permitting	BSEE Permitting	NMFS Permitting
Alternative 1 (Proposed Action)	The Proposed Action would result in 27.28 ac subject to Section 404 only (onshore impacts), 33 ac subject to both Section 404 and Section 10 (Territorial Seas impacts), and 32 ac subject to Section 10 only (OCS impacts). An Individual Permit would be issued under Section 404 and Section 10 authorities.	Issue an NPDES permit for five requested waste streams	Approve of PVP plans. Issue APDs for the wells. Issue Pipeline ROW grant.	Issue incidental take authorizations (ITAs) for take of marine mammals.
Alternative 2 (No Action)	No permit issued	No permit issued	No plans, permits or grants approved	No ITA for marine mammals issued.
Alternative 3A (Relocate LDPI Approximately 1 Mile to the East)	This alternative would result in 23.28 ac subject to Section 404 only (onshore impacts), 35.6 ac subject to both Section 404 and Section 10 (Territorial Seas impacts), and 34 ac subject to Section 10 only (OCS impacts). An Individual Permit would be issued under Section 404 and Section 10 authorities.	Same regulatory process as Alternative 1	Same regulatory process as Alternative 1	Same regulatory process as Alternative 1
Alternative 3B (Relocate LDPI approximately 1.5 miles to the southwest)	This alternative would result in 23.28 ac subject to Section 404 only (onshore impacts), and 59 ac subject to both Section 404 and Section 10 (Territorial Seas impacts). An Individual Permit would be issued under Section 404 and Section 10 authorities.	Same as Alternative 2; ADEC would be the permitting authority	Same regulatory process as Alternative 1	Same regulatory process as Alternative 1
Alternative 4A (Relocate Oil and Gas Processing to Endicott SDI)	This alternative would result in 18 ac subject to Section 404 only (onshore impacts), 51.6 ac subject to both Section 404 and Section 10 (Territorial Seas impacts), and 21.6 ac subject to Section 10 only (OCS impacts). An Individual Permit would be issued under Section 404 and Section 10 authorities.	Issue a NPDES permit for four waste streams to federal waters; ADEC is the permitting authority for discharges from the STP to state waters.	Same regulatory process as Alternative 1	Same regulatory process as Alternative 1
Alternative 4B (Relocate Oil and Gas Processing to a New Onshore Facility)	This alternative would result in 92.48 ac subject to Section 404 only (onshore impacts), 33 ac subject to both Section 404 and Section 10 (Territorial Seas impacts), and 26.4 ac subject to Section 10 only (OCS impacts). An Individual Permit would be issued under Section 404 and Section 10 authorities.	Same regulatory process as Alternative 4A	Same regulatory process as Alternative 1	Same regulatory process as Alternative 1
Alternative 5A (East Kadleroshilik River Mine Site #2)	The size of the material site, and hence the acres of wetlands impacted due to the site's development may differ depending on amount and quality of gravel at the site. Impacts for this alternative are generally the same as Alternative 1.	Same regulatory process as Alternative 1	Same regulatory process as Alternative 1	Same regulatory process as Alternative 1
Alternative 5B (East Kadleroshilik River Mine Site #3)	The size of the material site, and hence the acres of wetlands impacted due to the site's development may differ depending on amount and quality of gravel at the site. Impacts for this alternative are generally the same as Alternative 1.	Same regulatory process as Alternative 1	Same regulatory process as Alternative 1	Same regulatory process as Alternative 1
Alternative 5C (Duck Island Mine Site)	This alternative would result in 92.48 ac subject to Section 404 only (onshore impacts), 33 ac subject to both Section 404 and Section 10 (Territorial Seas impacts), and 26.4 ac subject to Section 10 only (OCS impacts). An Individual Permit would be issued under Section 404 and Section 10 authorities.	Same regulatory process as Alternative 1	Same regulatory process as Alternative 1	Same regulatory process as Alternative 1

¹: Onshore impacts include the gravel mine site, tie-in pad, ice road crossing pad, VSMS footprints, pipeline landfall trench and construction of onshore processing facilities (as applicable). Territorial Seas impacts include the construction located within Territorial Seas. OCS impacts include construction within OCS waters.

Table 2.2.7-5. Alternatives Comparison Table, Key Changes from the Proposed Action

Alternatives	Winter and Summer Access	Gravel Mine Site Development	Island Construction	Pipeline Construction	Facilities Construction	Drilling Operations	Production Operations	Decommissioning
Alternative 2 (No Action)	No Action	No Action	No Action	No Action	No Action	No Action	No Action	No Action
Alternative 3A (Relocate LDPI Approximately 1 Mile to the East)	Ice roads change length & course.	More gravel extracted, deeper mine site.	Larger island, further from Boulder Patch.	Longer pipeline, transits through strudel scour zone.	Same as Proposed Action.	Longer wells.	Same as Proposed Action.	Same as Proposed Action.
Alternative 3B (Relocate LDPI approximately 1.5 miles to the southwest)	Ice roads change length & course.	Less gravel extracted, shallower mine site.	Smaller island, further from the Boulder Patch.	Shorter pipeline.	Same as Proposed Action.	Longer and more complicated wells.	Same as Proposed Action.	Same as Proposed Action.
Alternative 4A (Relocate Oil and Gas Processing to Endicott SDI)	Ice roads change length & course.	Less gravel extracted, smaller mine site.	Smaller island.	Longer pipeline in close proximity to Boulder Patch.	Less construction on island, significant modifications to Endicott SDI facilities.	Same as Proposed Action.	Significant changes since processing facilities on Endicott SDI.	Additional work due to Endicott SDI facilities.
Alternative 4B (Relocate Oil and Gas Processing to a New Onshore Facility)	Ice roads change length & course.	Less gravel extracted from W. Kad #1 and Duck Island Mine Site.	Smaller island.	3-phase pipeline.	Less construction on island, additional onshore facilities.	Same as Proposed Action.	Significant changes since processing facilities onshore.	Additional work due to onshore facilities.
Alternative 5A (East Kadleroshilik River Mine Site #2)	Ice roads change length & course.	Different mine site location.	Same as Proposed Action.	Same as Proposed Action.	Same as Proposed Action.	Same as Proposed Action.	Same as Proposed Action.	Same as Proposed Action.
Alternative 5B (East Kadleroshilik River Mine Site #3)	Ice roads change length & course.	Different mine site location.	Same as Proposed Action.	Same as Proposed Action.	Same as Proposed Action.	Same as Proposed Action.	Same as Proposed Action.	Same as Proposed Action.
Alternative 5C (Duck Island Mine Site)	Ice roads change length & course.	Different mine site location.	Same as Proposed Action.	Same as Proposed Action.	Same as Proposed Action.	Same as Proposed Action.	Same as Proposed Action.	Same as Proposed Action.

2.3. Alternatives Considered but Not Carried Forward for Further Analysis

Several potential alternatives suggested during scoping are not considered for detailed study in this DEIS because they are not reasonable alternatives as defined under NEPA; an EIS (or DEIS) need not consider every conceivable alternative to a project. Rather, it must consider a reasonable range of potentially feasible alternatives that will foster informed decision making.

2.3.1. Ultra-Extended Reach Drilling (uERD)

In 2007, BP Exploration Alaska (BPXA) proposed to develop the Liberty Prospect by means of ultra-extended reach drilling (uERD) from the Endicott SDI. Recognizing that a uERD project of this length in the Arctic would be unprecedented, BPXA proposed to first drill a single uERD well to ensure such drilling was feasible before committing to this method for the entire project. The uERD approach required the design and construction of a new specialized drilling rig. After preparing an environmental assessment (USDOI, MMS, 2007a) and issuing a Finding of No Significant Impact (FONSI), MMS approved the DPP, thereby authorizing BPXA to proceed with their intended development approach. In June 2012, BPXA indicated that the new drilling rig still required substantial modifications to be functional and ultimately concluded in a November 20, 2012, letter to the BSEE that the uERD “concept was not the safest or most environmentally responsible course of development.” No further development actions occurred at the Liberty prospect under BPXA's DPP.

During scoping, Cooperating Agencies on this EIS suggested uERD as a potential alternative method for developing the Liberty Prospect, instead of constructing an artificial island in the Beaufort Sea. BOEM re-evaluated the feasibility of using uERD technology from two locations: Endicott SDI, or from the onshore site nearest the Liberty reservoir. BOEM's analysis utilized the following methodologies:

Technical Feasibility

1. Identify the technical challenges associated with uERD projects.
2. Identify the technical capabilities of existing uERD equipment on the Alaska North Slope as well as globally.
3. Determine if uERD development of the Liberty Prospect can be achieved using existing technology.

Economic Feasibility

1. Estimate the volume of resources that would be recovered from the Liberty Prospect if a uERD approach were used.
2. Estimate the commissioning costs of a uERD development concept at Liberty.
3. Compare the cost to recovery ratio of a Liberty uERD project with the cost to recovery ratios associated with other relevant projects.

Based on the findings of this feasibility analysis, BOEM has determined that an uERD is not a technically feasible manner of developing the Liberty prospect, because:

- A uERD approach to developing Liberty would require drilling highly deviated wells of unprecedented length. Wellbores drilled from the Endicott SDI or an onshore location would extend almost a mile beyond the existing world record of 40,602 ft for the longest wellbore.
- Technical challenges, including configuring drilling mud, hydraulics, casing strings up to four times as long as a standard well drilled at the reservoir, heating, and other systems are beyond those of existing drill rigs to manage.

BOEM's analysis also suggests that a uERD approach may not be economically feasible or capable of complying with BOEM regulatory requirements concerning sound conservation practices and protecting the rights of the lessor. A reservoir simulation performed by BOEM RE comparing the unchoked primary oil production of a well drilled at Liberty to that of an ultra-extended reach drilled well from Endicott indicates that additional uERD wells would need to be drilled to achieve the same production rate at Liberty. Additional uERD wells would need to be drilled to offset the higher frictional losses induced by the longer pipe lengths and larger cross-sectional area of the wellbore.

Because a uERD approach to developing the Liberty Project is not technically feasible and does not appear to be economically feasible, BOEM does not consider it a “reasonable” alternative, and this approach is not carried forward for full analysis in the EIS.

2.3.2. Horizontally Directional Drilling (HDD) Pipeline Landfall

The Proposed Action includes a pipeline to be installed via a trench from LDPI through the beachhead/dune and into the tundra, where it would surface and be elevated on VSMs. The landfall area would be reinforced with gravel, and thermosyphons would be installed to prevent thermokarsting (very irregular surfaces of marshy hollows and small hummocks formed as ice-rich permafrost thaws) and beach erosion in the area of the pipeline crossing (see Section 2.1.4 for more detail).

During scoping, it was suggested that BOEM evaluate an alternative whereby HDD, rather than trenching, would be used to transition between the onshore and offshore portions of the pipeline. This stated purpose behind this suggestion was to avoid/minimize coastal erosion and maintain the integrity of the beachhead/dune.

As an initial matter, BOEM notes that it does not expect the Liberty pipeline landfall to encourage coastal erosion. This expectation is based on BOEM's independent review of the proposed project as well as similar projects. For instance, coastal erosion rates at the Northstar Project's pipeline landfall, which was installed using similar trenching techniques, remain within the range of natural erosion observed prior to construction. The Liberty site is also more protected from storm surge by the Foggy Island Bay barrier islands and shoals, which further decreases the likelihood for any project-induced erosion. Meanwhile, BOEM finds that comparisons between the proposed Liberty pipeline landfall and the Badami pipeline's Sagavanirktok River crossing (where erosion has been observed) are not appropriate, due to dissimilarities in project specification and local environmental processes (i.e. riverine erosion versus shoreline erosion).

BOEM nevertheless assessed the feasibility of an HDD pipeline landfall. BOEM analysts identified the technical challenges of HDD projects in part by reviewing similar projects based on location, permafrost conditions, oceanic shoreline location, winter and/or ice conditions, borehole length and pipeline diameter. BOEM found that an HDD project of the type described during scoping would not be based on, or in accordance with, any typical HDD project. HDD for the pipeline landfall would need to begin several hundred feet offshore and extend to at least 0.25 mile onshore. Shore approaches using HDD are more complex than typical surface-to-surface HDD installations. HDD projects in Alaska have been installed onshore from surface-to-surface installations (e.g., Colville River pipeline crossing), but not from shore to sea. A schematic drawing of a possible offshore to onshore HDD is shown in Figure 2.3.2-1.

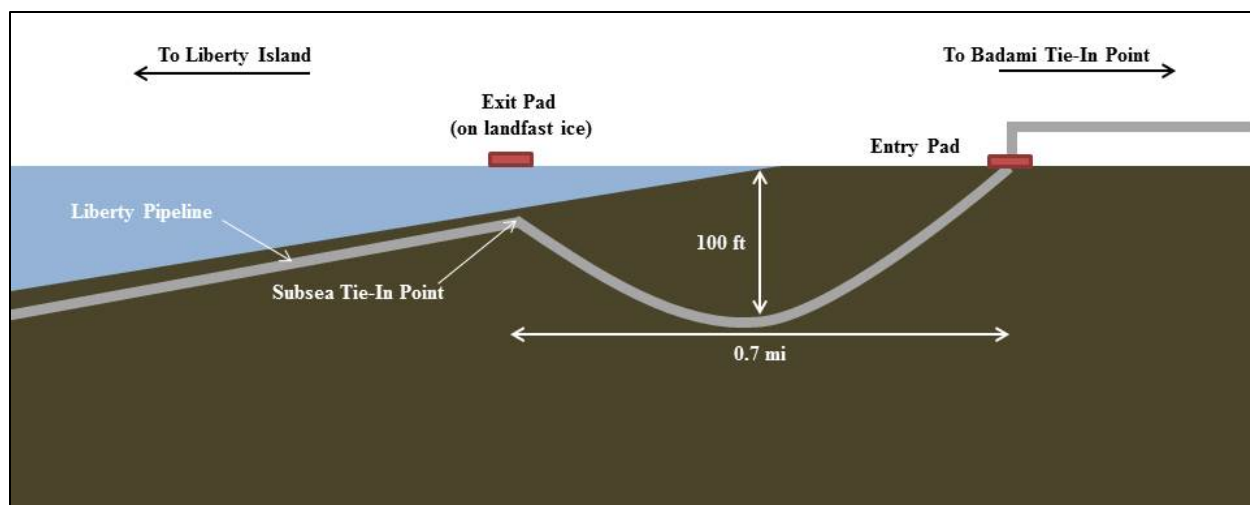

Figure 2.3.2-1. Schematic depicting a possible HDD alternative for the Liberty Project

The primary challenges/risks of an offshore to onshore HDD at this site include:

- **Exit site (offshore).** Placing the pipeline in summer (as proposed) would require storing the pipe offshore or on a barge. If stored offshore, it would be laid on the ocean floor, and an onshore anchoring and an offshore “pulling barge” would be needed to winch the pipe through the borehole from sea to land. Storing the pipe on a barge and winching it from the barge to the land is not feasible because the water depth is too shallow for a pipe-laying barge to operate. A possible method, although it would be experimental, would be to construct the borehole in winter from two stable surfaces (land and landfast ice).
- **Entry and exit elevation.** HDD entry and exit points should be as close to the same elevation as possible. For an HDD at this location, the difference in entry and exit elevations would range from 25 to 35 ft. While HDD is possible with this difference in elevation, the risk of pipe rupture increases.
- **Thermoregulation of soils.** For the HDD alternative, the pipeline would be drilled through permafrost soils, with no gravel backfill. Thus, the HDD pipeline and its associated heat would directly contact native soils. It is anticipated that this would result in greater permafrost thawing and associated subsidence, increasing risk of pipeline rupture/buckling.
- **Other technical issues.** With a 16” pipe-pin-pipe design, the Liberty pipeline would be largest HDD project attempted in Alaska. The large diameter increases the risk of hydraulic fracture and wellbore collapse.

A project of this nature has not been completed previously, and BOEM does not foresee how the difficulties associated with the shore approaches and the lack of an acceptable exit site could be overcome for this project. The compounding risks from potential hydraulic fracture and borehole collapse, and the presence of permafrost in the nearshore environment further contribute to a determination that using HDD is not a technically feasible approach for this project. Even if HDD were feasible, it would be a technically inferior engineering solution, given that the inability to surround the pipeline with thaw-stable materials would likely result in thawing of local permafrost and subsidence which could compromise the structural integrity of the Liberty pipeline. Due to technical infeasibility and heightened (rather than reduced) erosion concerns, BOEM does not consider an HDD pipeline landfall to be a reasonable alternative, and this approach is not carried forward for further analyzed in the EIS.

2.3.3. OCS Gravel Mining and Summer LDPI Construction

An alternative suggested during public scoping was to use gravel mined from the Federal OCS seabed to construct the LDPI during the open-water season. The commenter stated that there are several months of open-water conditions that could allow the project to be built with marine support rather than using ice roads. Constructing the LDPI using gravel mined from the OCS would eliminate much (but not all) of the project's need for onshore gravel. This concept is not considered a reasonable alternative warranting further analysis in the EIS, for the following reasons:

First, the technical and economic feasibility of this alternative is speculative. It is unknown whether the Beaufort Sea OCS (or other portions of the Alaska OCS) features a suitable gravel source. Also, the costs and environmental impacts of dredging and barging this gravel to the LDPI site would far exceed those from mining and trucking gravel from the proposed onshore mine located less than ten miles away.

Second, this alternative fails to meet the Purpose and Need for the proposed action. Requiring HAK to use gravel mined from the OCS would delay project implementation for several years. One or more open-water seasons of geological and geophysical surveying would be required to identify potential gravel sources. Mining rights must then be offered in a competitive lease sale, which would require at least 2 years of preparation. Further delays in project implementation would result from the shift from winter to summer mining and construction of the LDPI. The resulting years of delay would conflict with BOEM's mandate under OCSLA to facilitate expeditious development of OCS resources.

Finally, the implementation of this alternative would likely create unacceptable environmental and social impacts. The 2003 Liberty EIS, in addressing a similar suggested alternative, determined it would be "much more disruptive to wildlife, including the threatened and endangered species, which are in the project area only during summer, and subsistence activities in the area." This determination holds true today. The suggested alternative runs counter to stakeholders' consistent request that BOEM limit industrial activities in areas important to marine mammals and other key environmental resources, particularly during subsistence hunting periods.

2.4. Mitigation

Appendix C includes a description of mitigation measures contained in lease stipulations, design features and best management practices (BMPs) committed to by the operator, or permitting requirements expected to be imposed by other agencies. In analyzing potential impacts from the Proposed Action and other Action Alternatives, BOEM assumed implementation of, and compliance with, these mitigation measures.

In addition to these general mitigation measures, specific mitigation measures have also been developed to further avoid and minimize potential impacts. Below, BOEM describes a potential project-specific mitigation measure that would restrict drilling into hydrocarbon bearing zones to periods of solid ice conditions. Potential resource-specific mitigation measures (e.g., mitigation measures specific to migratory birds) are found in individual sections of Chapter 4.

2.4.1. Proposed Mitigation Measure

Seasonal Drilling Restriction

During scoping, BOEM received several comments which proposed seasonal restrictions on drilling into hydrocarbon zones as a means to reduce the likelihood of a large or very large oil spill contacting the Beaufort Sea and adjacent coastal areas during broken ice or open weather conditions. These comments suggested that oil spilled during solid ice conditions (as opposed to broken ice or open water conditions) would be easier to clean up, and thus less likely to affect subsistence activities, resources used for subsistence, and/or other marine mammals and threatened and endangered species.

Commenter recommendations varied in terms of length and timing of proposed drilling restrictions, but cumulatively, they suggesting limiting drilling into hydrocarbon zones to periods when 1) solid ice conditions surround the LDPI, and 2) there remained sufficient time to drill a relief well prior to spring break-up.

Based on these comments, and an independent review of factors relevant to development drilling and oil spill response techniques, BOEM developed for analysis in the Liberty DEIS a proposed mitigation measure that, if implemented, would restrict certain drilling activities on a seasonal basis. This proposed mitigation measure:

- Confines reservoir drilling to those times when at least 18” of ice exists in all areas within 500’ of the LDPI. The period of time during which reservoir drilling would be allowed typically starts approximately October 21st and ends approximately June 1st;
- Defines “reservoir drilling” as any drilling (whether for development, workovers, or completion) targeting the Kekituk Zone 2 formation which occurs either beyond the last casing interval above the reservoir or within 500 ft of the reservoir; and
- Allows for non-reservoir drilling and all other operations year-round (subject to the temporary annual suspension proposed in HAK’s DPP to avoid interference with subsistence hunting).

The practical effects of imposing such a restriction would be a change in the order in which HAK drills its wells and a potential delay (approximately 3-5 months) in completing the proposed drilling program. Waste disposal wells, as well as the top hole portions of development wells, could still be drilled year-round (subject to self-imposed limitations in HAK’s DPP).

Description of the Environment

This page intentionally left blank

Table of Contents

Chapter 3. Description of the Environment.....	3-1
3.1. Physical Environment.....	3-1
3.1.1. Bathymetry and Physiography.....	3-1
3.1.2. Oceanography.....	3-1
3.1.3. Oil and Gas Geology.....	3-9
3.1.4. Water Quality.....	3-12
3.1.5. Air Quality.....	3-19
3.1.6. Climate Change.....	3-22
3.2. Biological Environment.....	3-30
3.2.1. Lower Trophic Level Organisms.....	3-30
3.2.2. Fish.....	3-32
3.2.3. Birds.....	3-36
3.2.4. Marine Mammals.....	3-50
3.2.5. Terrestrial Mammals.....	3-108
3.2.6. Vegetation, Wetlands and Substrate.....	3-120
3.3. Sociocultural Systems.....	3-124
3.3.1. Sociocultural Systems.....	3-124
3.3.2. Economy.....	3-126
3.3.3. Subsistence Activities and Harvest Patterns.....	3-129
3.3.4. Community Health.....	3-145
3.3.5. Environmental Justice.....	3-152
3.3.6. Archaeological Resources.....	3-156

List of Figures

Figure 3.1.1-1. Bathymetry and Physiography.....	3-1
Figure 3.1.2-1. Stratified Water Column in Stefansson Sound.....	3-3
Figure 3.1.2-2. Mooring Locations within Stefansson Sound.....	3-6
Figure 3.1.2-3. Foggy Island Bay Ice Free or Near Ice Free Conditions: 2005 through 2016.....	3-7
Figure 3.1.2-4. Strudel Scours and Drain Cracks: 1997, 1998, and 1999.....	3-8
Figure 3.1.3-1. Arctic Alaska Petroleum Province.....	3-10
Figure 3.1.3-2. Up- and Down-Dip.....	3-11
Figure 3.1.4-1. BSMP Sampling Locations near Northstar and Liberty Islands.....	3-14
Figure 3.1.6-1. Global Atmospheric Concentrations of Carbon Dioxide over Time.....	3-24
Figure 3.1.6-2. Arctic Oscillation Phases.....	3-25
Figure 3.1.6-3. Chronological Temperature and CO ₂ Concentrations.....	3-26
Figure 3.1.6-4. Observed and Projected Changes in Global Average Temperature.....	3-27
Figure 3.1.6-5. Chronological Arctic Oscillation Phases.....	3-28
Figure 3.2.3-1. Sivulliq study Area.....	3-41
Figure 3.2.4-1. Liberty Proposed Action Area Beluga Whale Sightings: 2014.....	3-55
Figure 3.2.4-2. Beluga Whale Locations.....	3-56
Figure 3.2.4-3. Foggy Island Bay Beluga Whale Sightings: 2015.....	3-56
Figure 3.2.4-4. Belugas seen in the U.S Arctic during ASAMM surveys: 1979-2014.....	3-57

Figure 3.2.4-5.	Belugas near the Proposed Action Area during ASAMM surveys: 1979-2014 ..	3-58
Figure 3.2.4-6.	Belugas seen in the U.S Arctic during 2014 ASAMM surveys by month.	3-59
Figure 3.2.4-7.	Migration Route; Summer and Wintering areas – Western Arctic Bowhead.....	3-65
Figure 3.2.4-8.	ASAMM Bowhead Sightings, U.S. Arctic, July – August 1979-2014	3-66
Figure 3.2.4-9.	ASAMM Bowhead Sightings, U.S. Arctic, September – October 1979-2014....	3-67
Figure 3.2.4-10.	Bowhead Whales Seen Near Liberty during ASAMM Surveys 1979-2014.	3-68
Figure 3.2.4-11.	Bowhead whales seen in the U.S Arctic during 2014 ASAMM surveys	3-69
Figure 3.2.4-12.	Gray whales seen in the U.S. Arctic during ASAMM surveys 1979-2014.	3-75
Figure 3.2.4-13.	Gray Whales Seen near Liberty during ASAMM Surveys 1979-2014.	3-76
Figure 3.2.4-14.	Proposed Critical Habitat for the Arctic Ringed Seal in U.S. Waters	3-90
Figure 3.2.4-15.	Polar Bear Maternal Den Sites and Potential Maternal Denning Habitat.....	3-104
Figure 3.2.5-1.	Western Arctic and Central Arctic Caribou Herd Habitats.	3-110
Figure 3.2.5-2.	Teshekpuk, Porcupine, Tuktoyaktuk, and Cape Bathurst Caribou Herd Ranges	3-111
Figure 3.2.6-1.	Vegetation and Wetlands Delineation of the Proposed Action Area.....	3-120
Figure 3.3.3-1.	Subsistence Use Areas for Utqiagvik, Nuiqsut, and Kaktoviks.	3-132
Figure 3.3.3-2.	Nuiqsut/Cross Island Location and Travel Routes with Landmarks	3-135
Figure 3.3.3-3.	Bowhead Whale Sightings in the Vicinity of Cross Island.	3-136
Figure 3.3.3-4.	Nuiqsut Landed Whale Locations 1973-2013	3-137
Figure 3.3.6-1.	Potential Offshore Paleochannels.....	3-158

List of Tables

Table 3.1.2-1.	Seasonal Bottom Water Changes at McClure Mooring.....	3-4
Table 3.1.4-1.	River Discharges and Coastal Erosion Discharges into Marine Waters.....	3-13
Table 3.1.4-2.	Total Suspended Solids Sampled During Open Water.....	3-16
Table 3.1.4-3.	Total Suspended Solids Sampled near Northstar Island During Open Water.	3-16
Table 3.1.4-4.	Surface Water Relationship Between Wind Speed and Total Suspended Solids.	3-17
Table 3.1.5-1.	Existing Emissions (Tons per Year).....	3-22
Table 3.1.6-1.	Ice-Albedo Comparisons.	3-30
Table 3.2.4-1.	Boxcar Frequency Ranges for Marine Mammal Functional Hearing Groups ¹ ...	3-53
Table 3.2.4-2.	Impulse and Continuous Noise TTS and PTS Thresholds for Phocid Seals.	3-81
Table 3.2.6-1.	Summary of Wetlands Distribution in the Proposed Action Area.....	3-121
Table 3.3.2-1.	Employment and Wages for Alaska, NSB and Prudhoe Bay (2015).	3-127
Table 3.3.2-2.	Population of Permanent Residents (2015).	3-129
Table 3.3.3-1.	Utqiagvik, Nuiqsut, and Kaktovik Subsistence Resources and Peak Harvest. ¹	3-134
Table 3.3.5-1.	Ethnic Composition of Potentially Affected Communities ¹	3-153
Table 3.3.5-2.	Poverty Rates for Potentially Affected Communities. ¹	3-154

CHAPTER 3. DESCRIPTION OF THE ENVIRONMENT

3.1. Physical Environment

3.1.1. Bathymetry and Physiography

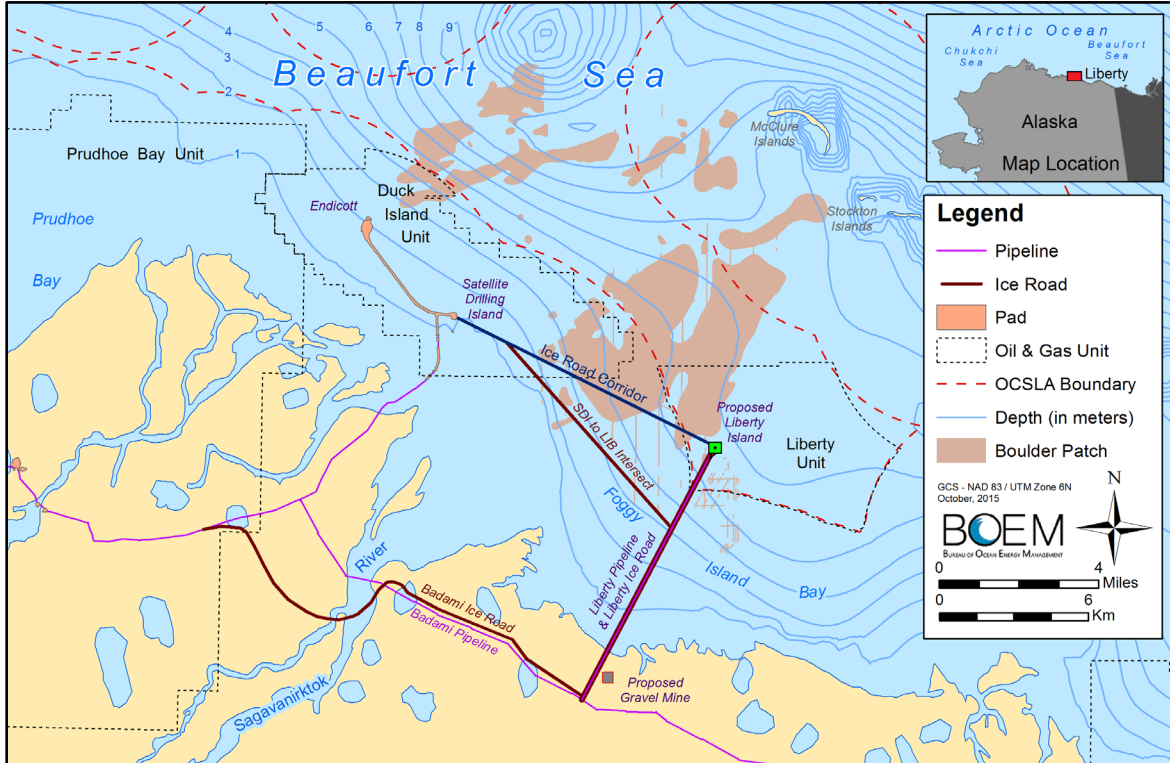

Figure 3.1.1-1. Bathymetry and Physiography. Illustration of the bathymetry and physiography in and around the Proposed Action Area. Map includes the Boulder Patch.

3.1.2. Oceanography

The Alaska Beaufort Sea shelf (Figure 3.1.1-1) extends approximately 311 miles (500 km) from the shelf area between Barrow Canyon and the Mackenzie Shelf in Canada. The continental shelf width ranges between 60 and 120 kilometers (37-75 mi) with an average water depth of 121 ft (36.9 m). Narrow and low relief barrier islands are found between 1 mile (1.6 km) and 12 miles (19 km) seaward of the coast. Foggy Island Bay is inside these barrier islands and has water depths of slightly less than 23 ft (7 m).

Foggy Island Bay is situated between the Sagavanirktok and Shaviovik rivers, and is sheltered by offshore shoals associated with Dinkum Sands and the McClure and Stockton barrier island complexes. Three rivers discharge into Foggy Island Bay: the Sagavanirktok River east channel, the Kadleroshilik River, and the Shaviovik River.

The Boulder Patch is an area near Foggy Island Bay characterized by a substrate of cobbles and boulders which were deposited by Pleistocene glaciers (Reimnitz and Ross, 1979; Wilce and Dunton, 2014). This type of substrate is uncommon in the Beaufort Sea. “Boulder Patch” is used to describe both the substrate and the diverse faunal community that relies on algae attached to the boulders. Sections 3.1.4 and 3.2.1 contain further description of the Boulder Patch.

Landfast ice begins to form in the fall months, thickening and growing seaward throughout the winter. It forms a protective barrier from the winds and sets up unique hydrographic conditions

beneath the ice canopy. In the spring and summer months, fresh water and sediment are added to the nearshore environment as landfast ice melts. BINGO

3.1.2.1. Circulation within Stefansson Sound

The dominant source of nearshore fresh water in the environment is the Beaufort Sea coastal river system, particularly the Sagavanirktok River. Freshwater discharge begins during the spring freshet as sediment-laden waters discharge on top of and beneath the landfast ice. Fresh water can move for many kilometers seaward beneath the landfast ice.

East of the Alaska Beaufort Shelf, the Mackenzie Canyon outflow can move large volumes of fresh and warm near surface waters westward to the area north of Stefansson Sound. These waters melt sea ice during the spring and early summer months and carry along nutrients, organic carbon, suspended sediments and plankton. Advection (horizontal flow of water) of Mackenzie Shelf waters depends on the persistence and strength of the Beaufort Sea winds. When winds are from the east, the Mackenzie Plume can be transported west to the Chukchi Sea. The migratory behavior of Arctic cisco is linked to the strength and persistence of the Mackenzie Plume westward track (ABR et al., 2007).

To the west, the influx of Pacific origin waters northward through the Bering Strait and onto the southern Chukchi Shelf diverges into three main channels. The waters most important to the Beaufort Shelf are those waters that advect northward on the Chukchi Shelf and then down Barrow Canyon. These waters exit the Canyon, pass Point Barrow, and continue east toward the Canadian Beaufort Sea along the shelf break.

In the absence of wind, the shelf break jet advects waters to the east. When the winds are from the west, the shelf break jet accelerates to the east causing downwelling of fresh water. In contrast, when winds are from the east, at speeds great than 4 meters per second (8.9 mph) the shelf break jet reverses direction to the west and upwelling of subsurface salty waters from the deep basin onto the shallow shelf can occur. These upwelling events can bring nutrients, carbon, and zooplankton onto the shallow shelf and spawn increased primary productivity. In addition to the waters within the shelfbreak jet, a portion of the Pacific water that flows through the head of Barrow Canyon spills out onto the shallow Beaufort Shelf before exiting the Barrow Canyon mouth. This flow can bring pacific-borne waters and their biological contents onto the shallow Beaufort Shelf and get transported eastward into the central Beaufort shelf.

Circulation in Foggy Island Bay and Stefansson Sound is strongly influenced by atmospheric forcing of wind-driven currents during the open water season. During the open water season, winds are the main driving force of surface and subsurface currents and the mixing of the water column.

Weingartner et al. (2009) conducted year-round measurements of subsurface currents utilizing acoustic Doppler current profilers (ADCP) that were moored to the seabed within the landfast ice zone of Stefansson Sound. These moorings measured the seasonal changes in subsurface currents with the growth and melting of the landfast ice cover.

The McClure Mooring was deployed in close proximity to the proposed Liberty Island site from September 4, 2000 through August 30, 2001.

During the spring freshet, the large and sudden discharge of fresh water from rivers can produce under-ice currents and increased turbidity (decrease in transmissivity). A significant portion of the river runoff flows beneath the landfast ice forming a strongly stratified water column (Figure 3.1.2-1). Weingartner, Okkonen, and Danielson (2005) estimated that the freshwater plume associated with spring river discharge can extend up to 20 kilometers offshore. During May and June 2004 and 2006 Alkire and Trefry (2006) measured an under-ice plume from the Sagavanirktok River that extended approximately 17 kilometers to the north and 15 kilometers to the west.

3.1.2.2. Salinity and Temperatures

Bottom water properties vary on a seasonal basis primarily as a result of the seasonal formation and melting of sea ice, the discharge of fresh waters from coastal rivers, and the mixing of the water column by winter stress during the open water season (Figure 3.1.2-1).

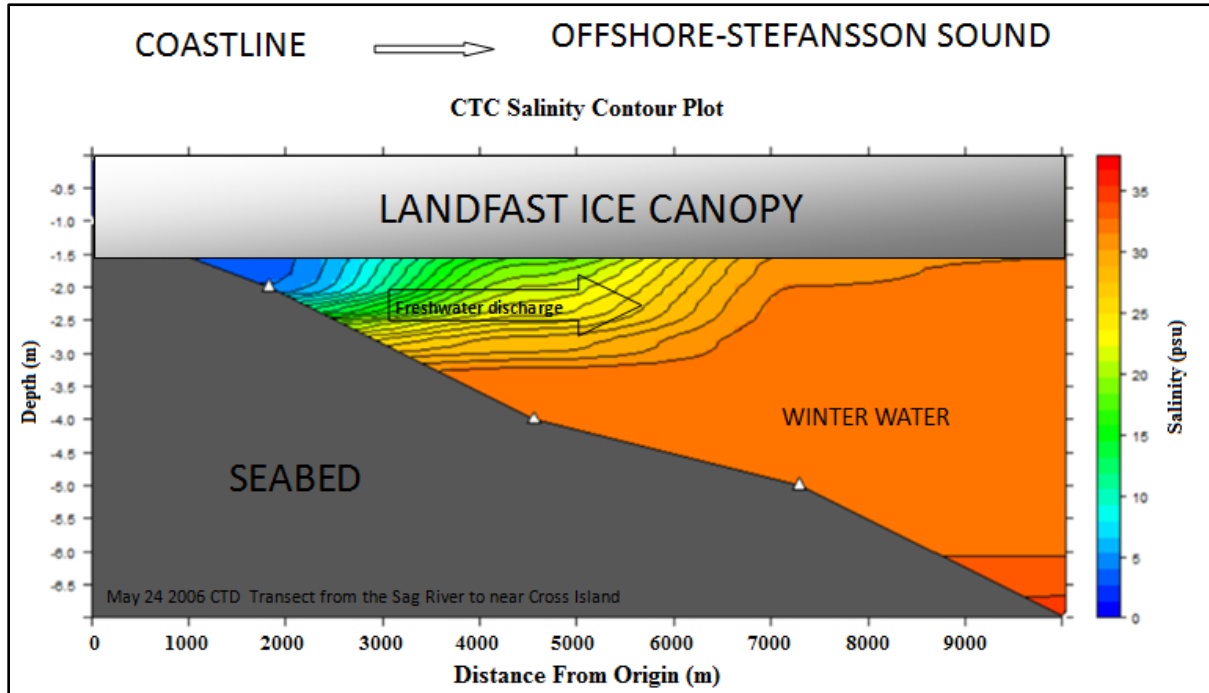

Figure 3.1.2-1. Stratified Water Column in Stefansson Sound. River discharge beneath the landfast ice canopy within Stefansson Sound forms a saline stratified water column. Depths and distances are in meters; Salinity is measured in practical salinity units.

The transition from fall to initial freeze-up conditions occurs during the month of September, when bottom water temperatures decrease from a high of 2°C, to a low of below -1°C (Figure 3.1.2-1). During this same period in 2000, air temperatures as measured from the West Dock Meteorological Station were below freezing and rapidly decreased throughout the month of September. Sea ice began to form adjacent to the McClure Mooring by mid-September, and completely covered the mooring by the end of September.

Bottom water temperatures remain very cold, near freezing levels, and bottom salinities increase rapidly during the winter months. During the early winter period, from November, 2000 through mid-April, 2001, ambient air temperatures rapidly decreased from -5° C to -35°C (23°F to -31°F), interrupted by minor pulses of warmer events. Sea ice thickened rapidly over the mooring, and bottom water temperatures decreasing below -1.5°C (29.3°F), whereas bottom water salinities rose sharply above 30 Practical Salinity Units (psu) to peak at over 35 psu by mid-April 2001.

Bottom water salinities slowly decrease and water temperatures slowly increase in late winter. Air temperatures were also on an upward trend. Ice thickness overlying the mooring was gradually decreasing from its peak of 2.3 meters (7.5 ft) in April. Concurrently, bottom water salinities were slowly decreasing and bottom water temperatures were slowly increasing (-1.8°C to 1.5°C (28.7°F - 29.3°F)).

Freshwater discharge from the Sagavanirktok River during the spring flooding season influences the temperatures and salinities of Stefansson Sound. Fresh and relatively warm water (slightly greater than 0°C (32°F)) from the Sagavanirktok River spring river plume flows out onto and under the

landfast ice where it mixes with marine water to form a 1.0- to 2 meters (3.3-6.6 ft) thick, under-ice lenses of brackish water that extends more than 15 kilometers (9.3 mi) offshore (Trefry et al., 2009). Fresh water transport of dissolved chemicals and land-borne contaminants can be transported long distances offshore (~20 kilometers (12.4 mi)) because the landfast ice canopy inhibits the mixing of the underlying water column from winds (Rember and Trefry, 2005). Turbidity values of suspended sediments as measured as Total Suspended Sediments (TSS) decrease from nearshore to offshore.

Later in the season, these coastal discharges of fresh water may get collectively entrained in the larger and stronger flows of such regional water masses as in the Mackenzie Plume and can get carried off the shelf and to the west. These local discharges can also move with the local nearshore circulation and retain their distinct geochemical signatures (Granskog et al, 2005). Freshwater river discharges that remain on the inner shelf can freshen the local waters, including those deep colder and saltier waters that were formed during the winter months from the formation of landfast ice (Eicken, 2005).

Bottom salinities decreased into mid-July (Table 3.1.2-1). Bottom water salinity values rapidly decreased from mid-July through the beginning of August before salinities reversed their trend into the fall season. Bottom water temperatures increased to above freezing values in July and August with the loss of sea ice and the concurrent mixing of the water column. At the same time, surface water salinities decrease and temperatures increase due to the mixing of river water throughout the water column. The fresh water initially creates a brackish nearshore zone with salinities of 10 to 15 parts per trillion (ppt). As shown in Table 3.1.2-1, when mixing begins, salinities increase to 15 to 25 ppt with water temperatures ranging from 0°C to 9°C (32°F-48.2°F). The nearshore waters become relatively well-mixed as the open-water season progresses, with salinities greater than 25 ppt and temperatures gradually decreasing to 0°C to 2°C (32°F-35.6°F).

Table 3.1.2-1. Seasonal Bottom Water Changes at McClure Mooring.

Season	Months	Bottom Temperature Range (°C)	Bottom Salinity Range (psu)
Fall Freeze-up	Sept to Early October	2 to -1	28-29
Early Winter	Mid-October to Mid-April	-1.5 to -1.8	27-36
Late Winter	Mid-April to May	-1.8 to -1.5	35
Spring Break-up	May-June to Mid- July	-1.7 to -1.5	32-35
Summer	Mid-July to August	-1.5 to 4.0	15-30

Note: Seasonal changes in bottom water temperatures and salinities were measured from the McClure Mooring from September 2000 through August 2001.

3.1.2.3. Water Levels

Given the relatively small tidal range, water level fluctuations in vicinity of the proposed LDPI are controlled more by the effects of wind stress than by astronomical tides. The moorings that Weingartner et al. (2009) deployed in Stefansson Sound showed significant correlations with eastward (downwelling-favorable) winds producing sea level increases and westward (upwelling – favorable) winds resulting in a decrease in sea levels during the open water season.

Seasonal variability in tides are small, although those associated with the spring flooding can be larger (Weingartner, 2009).

During the open-water season, wave heights are limited by the shallow waters adjacent to the coast and the shelter provided by barrier islands. Moreover, the proximity of the Arctic pack ice limits the fetch available for wave generation.

Beaufort Sea storms, and hence wave directions, can be classified as either easterly or westerly. Easterly storms typically are of longer duration than westerly storms (Oceanweather, 1982). Westerly storms often are accompanied by elevated coastal water levels (storm surge); while easterly storms may produce lower than normal water levels along the coastline. Westerly storms tend to be more severe, in part due to the associated storm surge.

Wave measurements were obtained in the vicinity of the Foggy Island Bay during the summers of 1980, 1981, and 1982, and 1983 in support of the Endicott Development (LGL Ecological Research Associates Inc. and Northern Technical Services, 1983, Sohio, 1983). In 1980 and 1981, wave heights were less than 0.6 meters (2 ft) approximately 90 percent of the time, with average wave periods <4 seconds. The maximum wave height measured was 1.7 meters (5.6 ft); the greatest wave height measured was 0.6 meters (2 ft) on October 6.

Given the scarcity of wave measurements in the Beaufort Sea, extreme wave information must be generated using oceanographic hindcast models. A site-specific hindcast of oceanographic conditions was conducted for the Proposed Action in 2013 (see 2015 Liberty EIA, page 3-16). Extreme wave statistics for easterly and westerly storms were predicted for four alternate island locations, the shoreline east of Point Brower, and the east side of the Satellite Drilling Island (SDI).

Wave heights associated with westerly storms were found to be larger than those for easterly storms. The 100-year westerly wave height at the island sites (located in a water depth of 5.5 to 5.8 m, MLLW) was predicted to be 2.6 meters with a period of 11.6 seconds. At the Satellite Drilling Island, located in a water depth of 1.8 meters (6 ft), the 100-year westerly wave height was predicted to be negligible, given the shelter provided by the Endicott Causeway (2015 Liberty EIA, Page 3-18).

3.1.2.4. Sea Ice

Sea ice initially forms in the shallow lagoons of Foggy Island Bay late September and early October, then gradually thickens and grows seaward in the form of landfast ice until Stefansson Sound is ice covered by the second or third week of October. Landfast ice stabilizes and thickens from October through mid- April and maintains a near stable thickness of 1.7-2.2 meters (5.6-7.2 ft) into May. Break-up of the nearshore landfast ice zone begins in late May and lasts through June or early July. During break-up, coastal rivers discharge warm fresh sediment laden water onto the landfast ice, hastening its near shore melting. Through July, the offshore sea ice (once attached to land as landfast ice) rapidly breaks-up, freshening the surface waters while dispersing large amounts of sediment and organic matter into the water column. Typically, by the third week in July the area within Foggy Island Bay is ice free, although small floating ice can drift into the waters within Stefansson Sound through August and sometimes into September, as was seen in 2015.

Weingartner et al. (2009) collected and analyzed six years of year-round ADCP and CTD data from five moorings deployed within the landfast ice zone of Stefansson Sound from 1999 through 2007. These moorings were deployed in relatively shallow water depths of less than 18 meters (59 ft) outside the Barrier Islands, and less than 10 meters (33 ft) inside the barrier islands (Figure 3.1.2-2). These moorings display the seasonal changes in ice thickness within Stefansson Sound. Based upon the mooring data, landfast ice setup dates varied between October 13 in 2001 and October 27 in 2004.

The transition from freeze-up to more stable landfast ice conditions in Foggy Island Bay and Stefansson Sound usually occurs in mid-November as the floating landfast ice growth attains a thickness of approximately 1 meter (3.3 ft). As the floating landfast ice sheet continues to grow, the temperatures in the bottom waters are near freezing, and ice begins to adhere to the sediments in shallow areas at water depths shallower than 2 meters (6.6 ft). This ice becomes anchored to the seabed as bottom fast ice.

During the early winter months, the mean extent of landfast ice covers much of Stefansson Sound, whereas in some years, the maximum extent can extend almost as far seaward as the 20 meter (66 ft) contour. By mid-November, there is less risk of ice movement, although the more stable period is when the mean extent of landfast ice reaches the Seaward Landfast Ice Edge (SLIE) in January. The proposed LDPI site becomes more stable as the ice grows confined by the shoreline of Foggy Island Bay to the south, the McClure Island chain to the north, Tigvariak Island to the east and Endicott SDI to the west. By May, the mean extent of the landfast ice is found seaward of the SLIE and the

maximum extent can reach the shelf edge. The landfast ice reaches a maximum thickness of between 1.7 and 2.2 meters (5.6-7.2 ft), stabilizing at between 2 and 2.5 meters (6.6-8.2 ft) through the end of May.

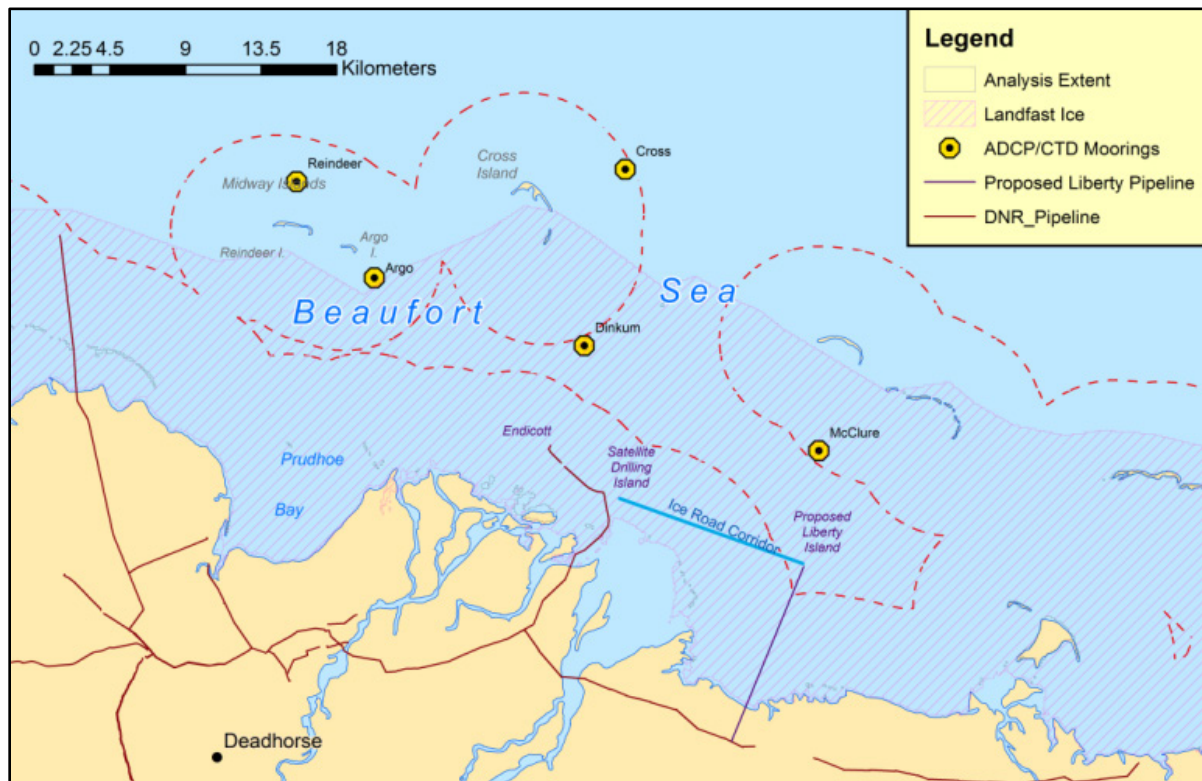

Figure 3.1.2-2. Mooring Locations within Stefansson Sound. Moorings were deployed within the Stefansson Sound area from 1999 through 2008 (Weingartner et al, 2009).

During the winter months, rapid changes in temperature may produce thermally induced shrinkage cracks in the floating landfast ice, usually propagating from sources of stress concentration, such as man-made gravel islands (including the Endicott SDI) or promontories along the coast, (e.g., Point Brower). In addition, a working tidal crack can be expected at the perimeter of the floating fast ice along the shoreline and around any grounded ice feature. Other than these minor cracking events, the first-year sheet ice in Stefansson Sound and Foggy Island Bay remains stable (Liberty DPP).

By early to mid-May, the ice sheet has weakened until ice roads can no longer support over-ice operations. Before the sea ice starts to show apparent signs of deterioration, melting snow in early May helps swell the upland river channels. During the spring freshet, in late May or early June, sediment laden waters flood out onto the landfast ice. The overflow waters can exceed a depth of 1 meter (3.3 ft) and can spread out several kilometers from shore. The overflow waters are transported over the nearshore bottomfast ice onto the floating landfast ice. The overflow waters then drain through holes and discontinuities in the landfast ice due to tidal cracks, thermal cracks, stress cracks, and seal breathing holes. This annual spring event results in a large decrease in transmissivity, an optical measurement of how light passes through a column of water measuring the concentration of particulate material in the water, which shows an increase in suspended sediment in the water column. These impacts can be observed many kilometers from shore as evident in the sharp drop in transmissivity values at the Dinkum Mooring in Stefansson Sound during the period of spring break-up for June 2000.

The warm sediment laden flood waters and increased solar radiation weaken the bottomfast ice, detaching it from the seabed. The flood waters gradually cover the nearshore area weakening the ice

platform. Just before break-up in late June and early July, the number of melt pools increases dramatically, covering approximately 40 to 50 percent of the sheet ice surface. Open water typically appears first along the shoreline and gradually expands along the coast and then seaward.

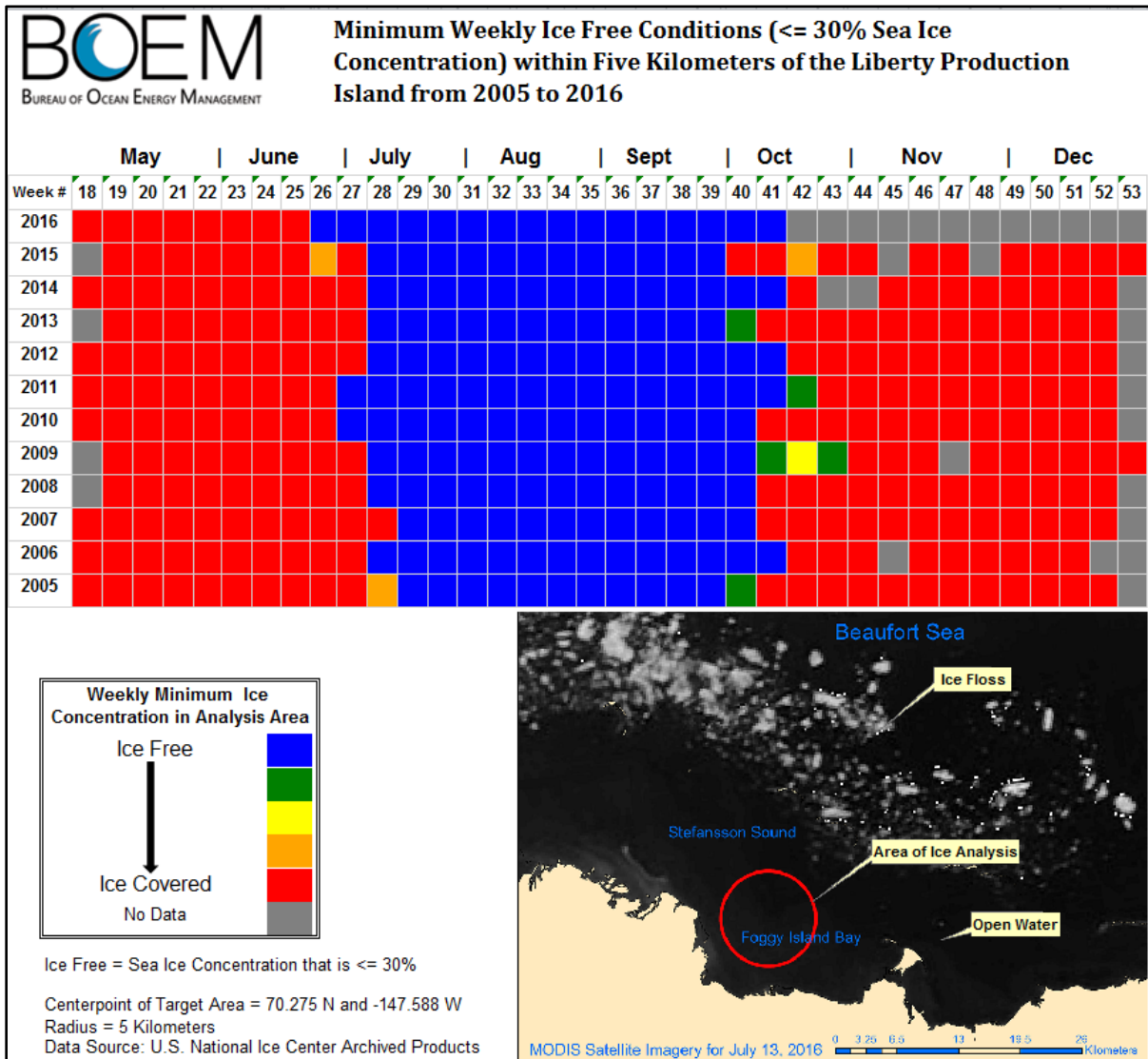

Figure 3.1.2-3. Foggy Island Bay Ice Free or Near Ice Free Conditions: 2005 through 2016. The blue boxes represent those weeks when the minimum ice concentration within the ice analysis polygon was less than or equal to 30%. An example of ice free conditions is shown within the MODIS satellite imagery for July 13, 2016 (bottom right). The blue to red squares represent the transition period from open water to ice covered conditions as larger areas of the ice analysis polygon contained ice concentrations that were greater than 30%.

Navigable ice conditions with no more than 30 percent ice coverage, (see Figure 3.1.2-3) occur between the months of July and September in most years, although open water can in some years occur as early as late June and as late as the second week of October, as shown for the year 2016.

Spring Flooding, Strudel Scours, and Impacts from Pipelines within Foggy Island Bay

The Sagavanirktok River east channel, the Kadleroshilik River, and the Shaviovik River discharge into Foggy Island Bay. The historical average break-up date along the coast for the Sagavanirktok River to overflow the sea ice is May 22, with a maximum date of June 3 and a minimum date of May

8th (Hearon et al, 2009). During the spring break-up period in late May and early June, coastal rivers discharge large volumes of fresh water on top of the coastal bottomfast and floating landfast. These flood waters can spread up to 10 kilometers offshore. This brief period of high volume energetic flow of surface waters can be considered a potential hazard to offshore oil and gas development operations, since these flooding events can hinder access to facilities, disperse spilled oil and expose buried pipelines through scouring of the seabed below the landfast ice zone as strudel scouring (Dickens, 2009).

The overflow and strudel scour field mapping and analysis for the Proposed Action were conducted by Coastal Frontiers Corporation for BPXA in 1997 and 1998. They mapped drainage features and overflow extents via a helicopter survey during spring break-up when bottom fast ice and landfast ice was still present offshore. During the open water season in August, they mapped the locations of strudel scours on the seabed using sidescan and multi-beam sonar. The recorded drain cracks drain holes, and strudel scours from those surveys are shown in Figure 3.1.2-4.

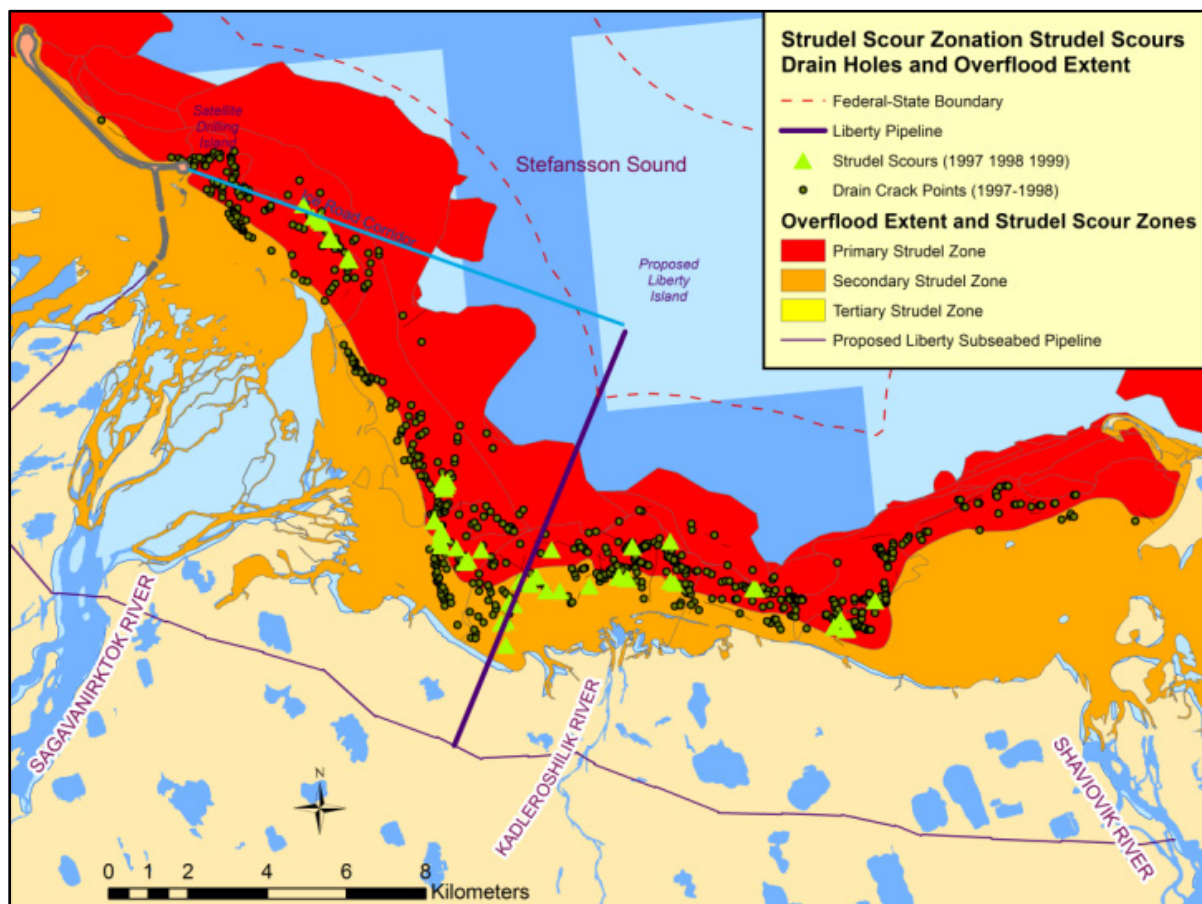

Figure 3.1.2-4. Strudel Scours and Drain Cracks – 1997, 1998, and 1999. *Overflow extent and strudel scour zonation in the Proposed Action Area.*

Strudel scours occur when overflow waters drains through tidal cracks, thermal cracks, stress cracks, or seal breathing holes in the landfast ice. Sufficiently deep strudel scours that form directly over a buried pipeline can remove the underlying fill and cause an unsupported span of pipe; they could also remove the overlying fill material needed to prevent damage from ice gouges and forestall upheaval bucking.

Hearon et al. (2009) also conducted a study to map the relationship between overflow extent, water depth, and strudel scour severity across the North Slope of Alaska. This study included the strudel

scour data from the strudel scour surveys conducted for this area in 1997 and 1998. They found that strudel scour frequency and severity could be segregated into separate overflow zones based upon water depth (Hearon et al, 2009). Strudel scouring is most widespread and acute within the Primary Strudel Zone (red zone on map) which extends from the seaward edge of the bottom fast ice edge at 1.5 meters water depth to the 6 meter (19.7 ft) water depth. In the zone of bottom fast ice or Secondary Strudel Zone (Orange) and offshore of the Primary Strudel Zone called the Tertiary Strudel Zone, scours occur on a less frequent basis and tend to be smaller in lateral and vertical extent to those found in the primary zone. Strudel scours that are circular in form were the most prevalent, whereas linear scours formed by drainage through elongated cracks were less frequently found, but were also measured. The maximum scour depths associated with Sagavanirktok River was 2.38 meters and maximum horizontal extent was 39.6 meters. These large scours occurred within the Primary Strudel Scour Zone. Seaward of the Kadleroshilik River, the deepest strudel scours did not exceed 1 meter for either zone.

Man-made features such as ice roads and causeways can play a significant role in focusing the direction of overflowing within the coastal zone. For example, Endicott Causeway can focus a larger area of floodwater along its length. During the construction of Northstar Island, the height of the ice road and ice berms along the road formed an artificial barrier that restricted the eastward movement of the Kuparuk River flood waters. The effect of these ice roads can create a higher density of strudel scours along this boundary. The presence of an operational pipeline can increase the scour frequency in the area overlying the pipelines due to radiant heat propagating through the backfill and degrading the overlying bottomfast and floating landfast ice (Hearon, 2009).

Ice Gouges

USGS conducted extensive ice gouge surveys on the Beaufort Sea Shelf in the 1970 and 1980's (Barnes et al., 1984; Barnes and Rearic, Remnitz, 1985; Barnes, McDowell, and Reimnitz, 1977; Wolf, Reimnitz, and Barnes, 1985; Rearic, 1986; and Rearic and Ticken 1988); and by the oil and gas industry related to oil and gas exploration in the 1980's and 1990's (Horowitz, 2002). These surveys found that most of the Beaufort Shelf area was heavily gouged, though the area within Foggy Island Bay had sparse ice gouging.

In some areas of the Beaufort Shelf, ice gouges completely cover the seabed, and gouge incision depth can be over 3 meters (9.8 ft). However, inside the protected area of barrier islands within Stefansson Sound and Foggy Island Bay ice gouges are significantly less prevalent with much shallower incision depths.

The first extensive ice gouge survey specific for the Proposed Action Area was conducted by Coastal Frontiers Corporation in 1997 and continued for a second year in 1998. The results of the ice gouge surveys in 1997 and 1998 suggest that the Proposed Action Area is not heavily gouged and the gouges only penetrate the seabed to very shallow depths of less than 0.5 meters (1.6 ft).

3.1.3. Oil and Gas Geology

3.1.3.1. Regional Geologic Setting

The Arctic Alaska Petroleum Province encompasses all the lands and adjacent Continental Shelf areas north of the Brooks Range-Herald arch, and is among the most petroleum-productive areas in the United States (Figure 3.1.3-1). Most of the known petroleum accumulations occur in three regional stratigraphic reservoir units called the Brookian, Beaufortian, and Ellesmerian. The Ellesmerian sequence includes rocks that are Mississippian through Triassic age and consist of mainly nonmarine to shallow marine siliciclastic deposits and carbonates that formed as continental shelf deposits on a passive margin (Bird, 2001). Oil production from the Ellesmerian sequence is from the Endicott, Lisburne, and Sadlerochit Groups.

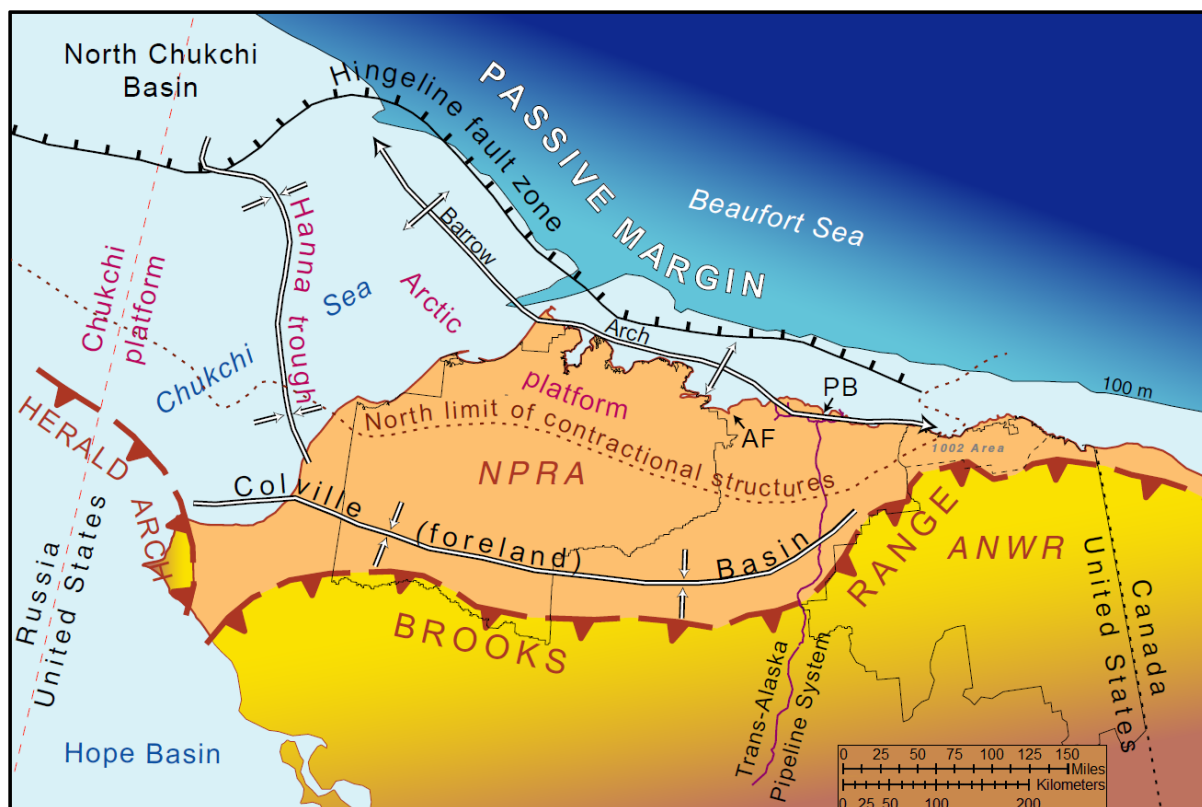

Figure 3.1.3-1. Arctic Alaska Petroleum Province.

3.1.3.2. Liberty Field

Reservoir Discovery

The Liberty Field is one of the largest undeveloped light-oil reservoirs near North Slope infrastructure. Located in Federal waters approximately six miles north of Mikkelson Bay and 15 miles east of Prudhoe Bay, the Liberty Field was discovered by Shell in the early 1980s and confirmed by BP in 1997. The Tern #3 and Liberty #1 wells established the presence of producible hydrocarbons within the Kekiktuk Formation. The Kekiktuk Formation is the lower most of three formations comprising the Endicott Group and is the oldest unit within the Ellesmerian Sequence. Two additional wells exist in the Proposed Action Area (Tern Island #1A and #2A) and provide additional data on the field.

Reservoir Analog

The Endicott Field, which is contained in the Duck Island Unit, is approximately five miles to the west northwest of the Liberty Field in State of Alaska waters. It is a reasonable analog for the Liberty Field because it has a similar geologic depositional environment and maturation history; analog information from the Endicott Field also provides useful insight into the Liberty Field rock, fluid, and other properties required for modeling and simulation studies. The primary geologic formation containing the hydrocarbon bearing resources in both the Endicott Field and the Liberty Field is the Kekiktuk Formation, and the development and depletion history of the Endicott Field provides insight into how the Liberty Field may respond to possible development activities.

Reservoir Model and Simulation Study

BOEM's 2016 independent reservoir model of the proposed Liberty Development and Production Plan, based upon best available exploration, discovery, and analog field information, estimates an

areal extent of approximately 2,355 acres with 180 million barrels of original oil in place (OOIP). The reservoir model consists of two producible zones separated by a thin non-flowing baffle zone with a tar layer at the base of the movable oil column. The porosity and permeability of the reservoir rocks (fluid containment and flow capacity) are assumed to be uniform and relatively homogeneous. Reservoir rocks typically are not flat but rather are folded and slope away from a localized high point. As fluids migrate within the rock layers, they separate, stratify, and collect due to their density differences. As a result, any free gas will migrate to the top or crest of a sloping structure with a sealing cap of impermeable rock while liquid hydrocarbons will collect below the free gas layer, if present, further down dip (liquid oil and water will always pool below gas in a reservoir). A water layer will separate out below the liquid hydrocarbon layer (Figure 3.1.3-2). If free gas does exist, it will be located “updip” in the highest portion of the reservoir rocks in a free gas cap. Rock layers can be thicker and thinner depending on deposition, erosion, and deformation histories. Based on an interpretation of seismic data, the reservoir is thickest in the northwest portion of the field and thins significantly downdip in the southeast direction. Seismic interpretation puts the top of the reservoir at 10,500 feet below mean sea level.

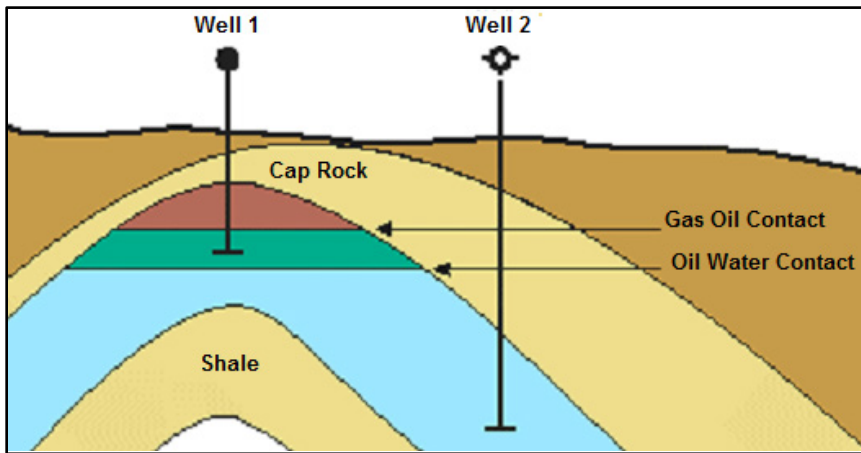

Figure 3.1.3-2. Up- and Down-Dip (location along the slope of a dipping plane or surface). In a dipping (not flat-lying) hydrocarbon reservoir that contains gas, oil and water, the gas is updip, the gas-oil contact is downdip from the gas, and the oil-water contact is still farther down-dip.

BOEM performed a reservoir simulation study using a full field reservoir model to evaluate reservoir development options and the likely production characteristics of the field. The development plan describes five producing wells, three water injection wells, and one gas or water injection well. As the first well drilled into the reservoir, the gas or water injection well penetrates the reservoir in the thick northwest updip section to evaluate if a gas cap is present. The development plan places three water injectors in the center of the reservoir with two producers to the northwest and up to three additional production wells in the southeast section of the reservoir. A water injection to oil production ratio of at least one barrel (bbl) water to one bbl oil will maintain reservoir pressure. As actual drilling, logging, and completion activities provide more information about the reservoir, well count and placement will adjust to optimize efficient recovery of oil from the Liberty Field.

The results of the full field reservoir simulation study of the BOEM reservoir model using the proposed development plan indicates that the Liberty Field would recover from 41% to 48% of the 180 million barrels of oil (MMBO) in place. The simulation study also indicates a peak production rate of 57,909 barrels of oil per day (BOPD) within the first two years of production.

Reservoir Access

Wells drilled from the surface into the Liberty Field reservoir would access and produce its hydrocarbons. A fixed platform is required to support the equipment used to access and produce those

hydrocarbons. In the Arctic, weather conditions including wind, water, and sea ice load motivate the use of manmade gravel islands instead of bottom-founded structures such as platforms and jack-up rigs when water depth is appropriate. The basic design concept for an Arctic offshore artificial gravel island involves the placement of suitable gravel materials with adequate height, mass, and slope protection and maintenance to secure the island against damage by wind, water, and ice forces over the productive life of the reservoir.

There are currently six manmade gravel islands in use for oil and gas development in the Beaufort Sea. The Duck Island Unit /Oilfield required three gravel islands for development - the Endicott Satellite Drilling Island (30 acres), Endicott Main Production Island (45 acres), and Endeavor Island. The Northstar Oilfield /Unit is accessed by Seal Island (5 acres). The Nikaitchuq Oilfield/Unit is accessed by Spy Island Drill Site (11 acres, not attached to the natural Spy Island). The Oooguruk Oilfield/Unit is accessed by Oooguruk Island. These gravel islands were built near their target reservoir or reservoir compartments supporting the optimum development of the trapped hydrocarbon resources with conventional, available, and field-proven technologies.

The proposed Liberty Drilling and Production Island (LDPI) would be the first permanent manmade gravel island built in Federal waters. From the LDPI, the Liberty Reservoir can be accessed and produced through conventional slant angle wells. The wells would be directionally drilled from the LDPI surface wellhead locations to reach the full extent of the reservoir with a departure of no more than 2.6 miles radius. This means that the bottom hole well location would be no more than 2.6 miles in a horizontal direction away from the well's surface location. The resulting well angles would allow for coiled tubing and /or wireline services as needed during the life of the wells. Coiled tubing refers to a long, continuous length of pipe wound on a spool that is straightened and pushed into a wellbore during well workover, intervention, or other operations. Wireline refers to the use of cabling technology to lower equipment into a well for workover, intervention, or other operations. Shallow well angles (e.g. horizontal or near horizontal wells) preclude the use of these standard well servicing conveyance mechanisms.

Reservoir Depletion

Studies of fluid samples from the Liberty #1 well indicate that the Liberty Field is a normally pressured reservoir containing light crude at normal reservoir temperatures. The fluid samples indicate hydrogen sulfide (H₂S) in small enough quantities to meet the classification of "H₂S Absent." Lab and field data indicate the reservoir may either have a gas cap or be near the oil's bubble point – the pressure at which gas begins to come out of solution. Keeping the pressure at or above the bubble point pressure is necessary to optimize the recovery of oil. As soon as possible after startup, any produced water would be separated from the produced reservoir fluids, combined with treated seawater, and reinjected to replace produced fluids and initiate waterflood enhanced oil recovery (EOR). Produced gas would be used on LDPI for fuel and to support artificial gas lift support with the unused portion reinjected into the reservoir for additional pressure maintenance and EOR. The waterflood and gas injection would optimize oil recovery and resource conservation.

Surface spacing between wellheads would be 15 feet and a maximum of 16 wellhead slots are planned for the well row. Initially, ten wells are planned to be drilled with five producing wells, four water and/or gas injection wells, and one disposal well. As wells are drilled and additional information about the Liberty reservoir and individual well performance is gathered, modifications to future well completion designs, placement, count, and other development aspects would be made to optimize field performance.

3.1.4. Water Quality

Stefansson Sound is about 20 kilometers northeast of Prudhoe Bay and immediately east of the Endicott production facility. Extending from the Midway Islands in the west to the Tigvariak Island

in the east, the sound is enclosed by a barrier island chain to the North, including Cross Island. The Proposed Action Area is located in the southwestern part of the Stefansson sound in Foggy Island Bay, at a water depth of about 5.8 meters (19 ft). The area includes the Sagavanirktok River Delta to the west and the Shaviovik River Delta to the east (Figure 1.2-1). The Kadleroshilik River flows into the central part of the bay.

Consisting of a mixture of marine and freshwater, coastal waters are transported through Foggy Island Bay based upon the direction of the prevailing winds. During the open-water season, the winds are generally from the east, driving water currents to the west. In addition to wind direction and speed, the characteristics of coastal waters are influenced by other factors including the season, amount of solar heating, coastal erosion, freshwater river/stream inputs and the characteristics of the terrestrial environment.

The quality of water, marine or freshwater, is determined by the water's physical, chemical and biological constituents. These individual attributes are derived atmospherically, terrestrially and from other sources of fresh or marine environments. Sediments, hydrocarbons and trace metals are examples of potential contaminants that are introduced into the marine environment by river runoff, coastal erosion, atmospheric deposition and naturally occurring hydrocarbon seeps. Table 3.1.4-1 shows the total solids entering the central Beaufort Sea by three major rivers and coastal erosion.

Table 3.1.4-1. River Discharges and Coastal Erosion Discharges into Marine Waters.

River/Drainage	Peak River Flow	Annual Rate River Flow	Total Solids
Sagavanirktok River	300 - 1200 (m ³ /sec)	~6.5 km ³ /year	330,000 Metric Tons/Year
Kuparuk River	500 - 3500 (m ³ /sec)	~1.2 km ³ /year	21,000 Metric Tons/Year
Colville River	~8500 (m ³ /sec)	~15 km ³ /year	~5,000,000 Metric Tons/Year
Coastal Erosion	---	---	~1,000,000 Metric Tons/Year
Total	---	~22.7 km ³ /year	~6,350,000 Metric Tons/Year

Notes: Table summarizes the rate of discharge of water and total solids from the three largest North Slope Rivers and from coastal erosion into the Proposed Action Area of the central Alaskan Beaufort Sea. Peak flow and sediment discharge, representing 30 to 90% of the total annual discharge, occurs during 3 – 12 days in late May and early June each year (Neff, 2010a).

Sources: Rember and Trefry, 2004; Trefry et al., 2004; Alkire and Trefry, 2006.

Studies by AMAP (1997, 2004) and Hopcroft et al. (2008), state that existing degradation of Beaufort Sea OCS water quality is primarily related to aerosol transport and deposition of pollutants; pollutant transport into the region by sea ice, biota and currents; and from increasing greenhouse gases in the atmosphere, which affect water temperature and acidity.

The Colville, Kuparuk, Sagavanirktok and Canning rivers that flow into the Alaskan Beaufort Sea remain relatively unpolluted by humans, however man-made pollutants in the Project Area may be present. Sources of pollutants are primarily the result of industrial activities related to the petroleum industry and include wastewater discharges and accidental spills of crude or petroleum or other substances.

For a complete discussion on regulatory controls over permitted point-source discharges, see Section 2.1.9, EPA Permitting Requirements for the Proposed Action.

Characteristics of the Beaufort Sea

Much of our current understanding of the Beaufort Sea is due, in part, to the development of oil and gas resources of Alaska's North Slope, exploration activities along the coast and offshore, and development and production offshore in State waters.

BOEMRE Alaska OCS Region is responsible for managing oil and gas development in Federal waters of Alaska, including the Beaufort and Chukchi Seas and beginning in 1979 the Beaufort Sea continental shelf was made available for exploratory drilling. Since then BOEMRE has sponsored three major environmental effects monitoring projects in the Beaufort Sea: The Beaufort Sea

Monitoring Program (BSMP), the Arctic Nearshore Impact Monitoring in the Development Area (ANIMIDA) Project and the Continuation of the Arctic Nearshore Impact Monitoring in the Development Area (cANIMIDA) Project (Neff, 2010a.) Figure 3.1.4-1 illustrates the BSMP water sampling stations in the areas of the proposed LDPI and Northstar Island.

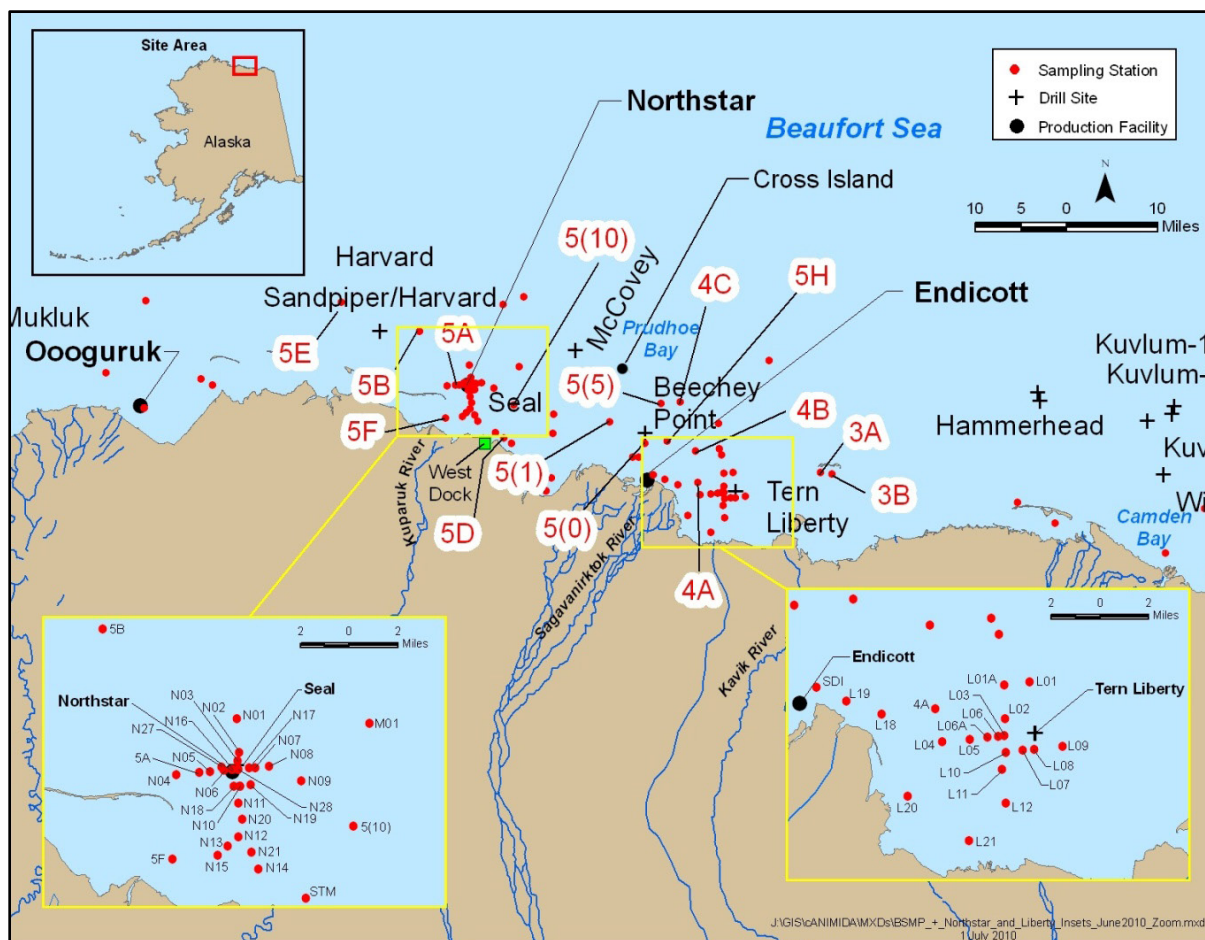

Figure 3.1.4-1. BSMP Sampling Locations near Northstar and Liberty Islands. Stations displayed have been sampled in relation to the cANIMIDA Program near to exploration drilling sites and production facilities (Neff, 2010a).

The Beaufort Sea Monitoring Program was initiated in 1984 to develop and implement a monitoring program for evaluating potential impacts of anticipated offshore oil and gas exploration and production activities on the Beaufort Sea continental shelf.

The primary objectives of the more recent ANIMIDA and cANIMIDA studies were to monitor and characterize the marine environment of the Northstar and Liberty development areas and to evaluate potential and actual effects of these major offshore oil developments (Neff, 2010a). The ANIMIDA Project Phase 1 (1999, 2000) was designed and implemented with a focus on the 1999 late-summer open-water period and the 2000 winter ice-covered period. The late summer 1999 sampling represented pre-construction baselines at both the Northstar and Liberty areas. Final results from Phase 1 of the ANIMIDA Project were summarized in a report titled, “ANIMIDA Phase I: Arctic Nearshore Characterization and Monitoring of the Physical Environment in the Northstar and Liberty Development Areas” (Boehm et al., 2001).

Phase 2 of ANIMIDA focused on monitoring during the summers of 2000 and 2002 and sampled at the same Northstar and Liberty stations sampled in Phase 1. The winter 2000 sampling represented

the first construction monitoring period at Northstar and another pre-construction opportunity for the Liberty Area (Neff, 2010a).

The cANIMIDA Project extended Phase 2 ANIMIDA field program to the summers of 2004, 2005, and 2006 with the explicit goal of examining the temporal and spatial changes and to determine if any observed changes in chemical and biological characteristics of the development area of the Beaufort Sea are related to the current Northstar development and production operations (Neff, 2010a).

Among the numerous tasks assigned to the cANIMIDA project, aspects of the following points are applicable to this analysis:

- Determine the major element, trace metal and organic carbon content of water and suspended sediments carried to the coastal Beaufort Sea by the Sagavanirktok, Kuparuk and Colville Rivers
- What are the background concentrations of metals and hydrocarbons known to be associated with oil exploration, development and production activities and are the concentrations of these chemical increasing in area sediments as a result of development and production
- Determine concentrations of suspended sediments, dissolved metals, particulate metals and supporting parameters in the coastal Beaufort Sea
- Determine the impacts of TSS on kelp productivity and ecosystem status in the Stefansson Sound Boulder Patch

The results of both the ANIMIDA and cANIMIDA were integrated in a final synthesis report entitled, “*Continuation of the Arctic Nearshore Impact Monitoring in the Development Area (cANIMIDA) Synthesis, 1999-2007*” (Neff, 2010a).

Total Suspended Solids – (Turbidity)

Summer – Open Water

Turbidity is caused by fine-grained particles suspended in the water column. These particles come from rivers discharging into the marine environment, coastal erosion, and resuspension by wave action of particles deposited on the seafloor. Seafloor sediments in Foggy Island Bay include a heterogeneous mixture fine sand, silt, and clay-sized particles less than 0.250 millimeter (0.01 in) in diameter. Turbidity blocks light and measurably reduces primary productivity of waters shallower than about 12 meters (40 ft).

On the Alaskan North Slope, the frozen tundra and snow pack upstream begin to melt during spring and meltwater slowly flows downstream (northward), melting the river water en route. The meltwater carries particulate and dissolved components frozen in the ice and snow from the previous year along with weathered rock and soil layers from the surrounding river banks. This thawing and weathering contribute to the specific chemical compositions of the particulate and aqueous phases carried by each river. During high discharge, that lasts only 1 to 2 weeks, Alaskan Arctic Rivers typically transport 40% to 80% of their total annual discharge of water and > 80% of their load of suspended sediments (Neff, 2010; Rember and Trefry, 2004). As a result, spring melt and river runoff not only contribute substantial freshwater to the marine system, but also greatly influence the characteristics of nearshore waters of the Beaufort Sea. For this reason, measuring and understanding the water quality of the major contributing river systems on the North Slope is critical in understanding the water quality of the coastal Beaufort Sea.

Concentrations of total suspended solids (TSS) in the spring water flow from the Sagavanirktok, Kuparuk and Colville Rivers are highly variable among year and within each annual spring flood. Based on data collected during the cANIMIDA Project, TSS concentrations were highest in the Colville River and lowest in the Kuparuk River. While daily concentrations varied, about 90% of the

annual transport of TSS from rivers occurs during the spring flood (Neff, 2010a; Trefry et al., 2009). Table 3.1.4-2 shows the mean, maximum and minimum concentrations of TSS in the Kuparuk, Sagavanirktok and Colville Rivers during May-June of the years listed.

Deltas at the mouths of rivers indicate deposition of riverborne sediments and the composition of the suspended matter in rivers can provide a geochemical signature that may allow differentiation between incoming natural suspended sediment and anthropogenic contributions from industrial activity in the coastal Beaufort Sea (Neff, 2010a). Suspended sediments and turbidity, and particulate and dissolved metals in the water column were monitored during the cANIMIDA Project at several nearshore stations off the Sagavanirktok and Kuparuk Rivers, at selected stations near Northstar, in the Proposed Action Area and historic BSMP stations (See Figure 3.1.4-1). A summary of this data for total suspended solids (TSS) for all stations in the ANIMIDA and cANIMIDA study area during the open water period and for a subset of stations in the area of Northstar Island can be seen at Tables 3.1.4-2 and 3.1.4-3 (Trefry et al., 2009).

Table 3.1.4-2. Total Suspended Solids Sampled During Open Water.

Sampling Year	Samples Taken	TSS Mean \pm SD (mg/L)	TSS Maximum (mg/L)	TSS Minimum (mg/L)
1999	31	30 \pm 27	119	2.9
2000	51	8.2 \pm 4.8	26	1.7
2001	34	5.1 \pm 2.1	8.7	0.9
2002	32	2.1 \pm 1.3	4.4	0.2
2004	45	13 \pm 16	64	0.5
2005	65	1.7 \pm 1.4	6.7	0.3
2006	26	1.3 \pm 0.7	4.0	0.4

Notes: SD = Standard Deviation; TSS=Total Suspended Solids

Samples taken from all ANIMIDA and cANIMIDA Sampling Stations in the study area during the open-water period.

Source: Trefry et al., 2009

The mean concentrations of TSS were higher for years 1999, 2000 and 2004. The very high TSS value in 1999 is probably a reflection of the weather conditions under which it was collected. Much of the 1999 data set was collected following a 5-day storm with >20 knot winds. In contrast, 2002, 2005 and 2006 data were collected during relatively calm conditions with considerable sea ice throughout the study area (Neff, 2010a). During 2000, 2001 and 2004 sampling periods, conditions were moderate with 5 to 15 knot winds during most of the sampling period. During 2004, relative calm was encountered during most of the study period as reflected in the low mean value for TSS in the Northstar area and in much of the study area. Thus during a given summer, the mean and range of measured TSS concentrations typically reflect the winds and weather (Neff, 2010a; Trefry et al., 2004).

Table 3.1.4-3. Total Suspended Solids Sampled near Northstar Island During Open Water.

Northstar Area	Samples Taken	TSS Mean \pm SD (mg/L)	TSS Maximum (mg/L)	TSS Minimum (mg/L)
1999	17	38 \pm 33	119	2.9
2000	35	7.3 \pm 4.0	16	1.7
2001	15	4.1 \pm 1.8	6.3	0.9
2002	11	2.5 \pm 1.5	4.4	0.2
2004	15	6.2 \pm 4.8	16	0.5
2005	9	1.4 \pm 0.8	3.6	0.8
2006	12	1.1 \pm 0.4	2.1	0.6

Notes: SD = Standard Deviation; TSS=Total Suspended Solids

Samples were taken from ANIMIDA and cANIMIDA Sampling Stations near Northstar Island during the open-water period.

Source: Trefry et al., 2009

As noted in Table 3.1.4-4 (Trefrey et al., 2009) TSS concentrations are strongly correlated with wind and sea conditions during the open water season. TSS concentrations tend to be low until the wind

speed exceeds 20 knots when current and wave action intensifies. Bottom sediments are re-suspended and TSS levels would increase to 50 – 100 mg/L or more under stormy conditions.

Data from the cANIMIDA and from many other vertical profiles and horizontal tows presented in previous reports (Trefry et al., 2004) show no significant differences in turbidity or concentrations of TSS in proximity (within 100 to 500 m) to Northstar Island relative to other locations in the ANIMIDA study area.

Table 3.1.4-4. Surface Water Relationship between Wind Speed and Total Suspended Solids.

Wind Speed (Knots)	TSS Concentration (mg/L)
Calm to 5	~1 – 4
5 - 10	3 – 8
10 to 20	5 to 15
> 20	50 - >100
Under Ice	<0.1 - 0.5

Notes: Relationship between wind speed and total suspended solids (TSS) concentrations in surface waters of the Beaufort Sea development area during the open water season. Under- ice TSS concentration range is included for comparison.

Source: Trefry et al., 2004.

Winter – Ice Covered Period

In April 2000, as part of the ANIMIDA project, the concentrations of suspended-particulate matter at various depths in the water column under about 2 meters of ice were determined from water samples collected from stations in the vicinity of the Endicott development island, the Northstar island and in Foggy Island Bay, in the vicinity of the proposed Liberty Project Area (Boehm et al., 2001). Total suspended-solids measurements ranged from 0.14 – 0.58 milligrams per liter; turbidity measurements ranged from 0.15 -070 nephelometric turbidity units (Boehm et al., 2001). These concentration ranges were lower than the concentrations of suspended-particulate matter in the column in August 1999. The ANIMIDA also reported that during the winter ice covered season, TSS levels tend to be about 10 to >100 times lower than values obtained during the open-water period averaging 0.25 ± 0.06 mg/L.

Suspended sediment concentrations measured during the winter construction of BF-37, a gravel island located about 3 kilometers north of the Endicott MPI, showed that TSS did not increase significantly near the island. Suspended sediment concentrations were measured during the first seven days after fill placement, at radial distances of 140 meters and 170 meters from the island. The maximum TSS concentration increase relative to ambient conditions was 3 mg/L. It was speculated that the sediment plume was limited by low under-ice currents, ice bonding of fine-grained material and the formation of silt/ice agglomerates (Coastal Frontiers, 2014).

TSS and the Stefansson Sound Boulder Patch

The Proposed Action Area includes an area commonly referred to as the “Stefansson Sound Boulder Patch,” or simply Boulder Patch. The Boulder Patch is characterized by boulders, cobbles and pebbles that cover large areas of silt-clay sediment. The Stefansson Sound Boulder Patch supports the only known kelp bed on the Alaskan Arctic coast (Dunton, 2005; Neff, 2010a) where the endemic Arctic kelp *Laminaria solidungula* is abundant in the area. Growth and production of the kelp bed is regulated primarily by PAR (photosynthetically active radiation) available during the summer open-water period and any variation in underwater PAR caused by changes in water transparency can have significant effects on the annual productivity of this species (Dunton, 2005).

The ANIMIDA and cANIMIDA Projects performed field surveys and monitored water quality parameters during the summers of 2001 through 2006. The initial effort in the ANIMIDA Project was focused on establishing a quantitative relationship between TSS and benthic kelp productivity (Aumack et al., 2007; Neff, 2010a).

The cANIMIDA Project elaborated further to determine the impact of sediment resuspension on kelp productivity and to address any ecosystem change as related to anthropogenic activities from oil and gas development, particularly in the proposed Liberty Project Area. Thirty sites from across the monitoring area were sampled during the summer of 2004, 2005 and 2006 in order to describe the spatial extent and patterns of TSS, light attenuation, chlorophyll, nutrients and physicochemical properties across Stefansson Sound (Neff, 2010a). A general trend of decreasing TSS with distance offshore was observed in all three sampling years (see Figure 3-59, Neff, 2010a).

Dissolved and Particulate Metals

Trefry et al. (2009) noted that barium, copper, chromium, nickel, and lead comprised more than 85% of the TSS. The concentrations of these metals in the Beaufort Sea sediment are not significantly influenced by anthropogenic inputs or diagenetic (transformation into sedimentary rock) processes but assumed to be naturally occurring and originating from geophysical formations of the rivers and their tributaries (Neff, 2010b). Neff (2010a) found no significant differences in concentrations of TSS due to oil and gas operations near Northstar Island relative to the overall cANIMIDA study area.

Vessel Discharge

Vessels can affect water quality through deck drainage, sanitary and domestic discharges, brine and cooling water discharges, small spills, anchoring in benthic habitat, disturbance of microlayer and potential for introduction of invasive species from foreign or out-of-state vessels. In winter, ice breakers could affect the movement of spilled oil that may be trapped beneath or in the ice. Vessels >79 ft in length operating as a method of transportation would require NPDES permit coverage for incidental discharges under the Final 2013 Vessel General Permit for Discharges Incidental to the Normal Operation of Vessels (VGP) (EPA, 2013). The VGP establishes effluent limitations to control materials that contain constituents of concern in the waste streams from vessels. In addition to complying with NPDES requirements, vessels discharging in the contiguous zone and ocean (seaward of the outer limit of the territorial seas) are subject to MARPOL 73/78, implemented by the USCG pursuant to 33 CFR 151. Vessels <79 ft in length that are operating as a method of transportation may be covered under the VGP, or may instead opt for coverage under the small VGP (sVGP) issued by the EPA. Discharges from seismic survey vessels and support vessels used during exploration activities would be covered by the VGP.

Climate Change and Ocean Acidification

Ocean acidification in the marine environment is occurring as carbon dioxide (CO₂) increases in the atmosphere and the ocean absorbs more CO₂ (AMAP, 2013). This increase in CO₂ forces an increase in hydrogen ion concentration and a lowering of pH over time. Decreasing pH changes the equilibrium of the inorganic carbon system in the sea by reducing the concentration of carbonate ions (CO₃⁻²), an essential molecule for many organisms that produce structures of calcium carbonate (CaCO₃).

Researchers (AMAP, 2013; Steinacher et al., 2009; IPCC, 2013; Mathis et al., 2015a; Mathis et al., 2015b; Mathis et al., 2014; Mathis, Cross and Bates, 2011) found that the greatest degree of ocean acidification worldwide is predicted to occur in the Arctic Ocean (AMAP, 2013). This amplified scenario in the Arctic is related to:

Warming air temperatures; sea-ice decrease resulting in a greater surface area of the sea exposed to atmospheric CO₂

- Increases in the occurrences of phytoplankton blooms
- Increased freshwater from snowmelt, ice-melt, and rivers discharged to the marine environment
- Decomposition in the sea of land-originated organic matter

- Increase in storm frequency and intensity forcing mixing and upwelling of organic matter

If CO₂ continues to increase in the atmosphere at the current rate, it is predicted that the future rate of pH decrease would be greater than the current rate of pH decrease (Mathis et al., 2015a; Mathis et al., 2015b; Mathis et al., 2014; Steinacher et al., 2009; IPCC, 2013).

Increasing ocean acidification is predicted to cause changes in ecosystem processes and present additional stressors to organisms in the Arctic (Mathis et al., 2015a; Mathis et al., 2015b; Mathis et al., 2014; AMAP, 2013; Kroeker et al., 2013; Steinacher et al., 2009; Bednaršek et al., 2014; Fabry et al., 2008, 2009). Decreased thickness of calcium carbonate structures, and in some cases increased structure thickness has been demonstrated with depressed pH (Reis et al., 2009). Decreased pH can also affect other important physiological functions such as cell function (Rossi et al., 2015; Portner, 2008; Dupont et al., 2008).

The Arctic Monitoring and Assessment Programme notes:

“Sea-ice cover, freshwater inputs, and plant growth and decay can also influence local ocean acidification. The contributions of these processes vary not only from place to place, but also season to season, and year to year. The result is a complex, unevenly distributed, ever-changing mosaic of Arctic acidification states” (AMAP, 2014).

3.1.5. Air Quality

The Environmental Impact Analysis provided in Section 3.4 of Appendix A to the Liberty Development and Production Plan (DPP) provides an in-depth description of the air quality over the area of affected environment. This analysis is incorporated here by reference and summarized below, with additional supporting and new scientific information included where available.

Contaminants that deteriorate the quality of ambient air can, when present in sufficient concentrations and for sufficient time, cause poor air quality that endangers human health and the environment. The pollutants may be comprised of gaseous, liquid, or solid substances. Contamination of ambient air can be the result of both natural (biogenic) factors such as volcanic eruptions and spontaneous forest fires, and man-made (anthropogenic) factors such as burning of fossil fuels. Poor air quality occurs when concentrations of pollutants from these sources reach levels high enough to be a danger to human health and the environment.

To discern what constitutes poor air quality and where it occurs, the EPA has established National Ambient Air Quality Standards (NAAQS) along with a monitoring system to identify geographical areas where the standards are exceeded. The NAAQS are comprised of science-based “limiting criteria” which define maximum concentrations of six air pollutants the U.S. Congress defines as having the potential to endanger human health and the environment when found in high enough concentrations. Each state can also establish their own standards for air quality, but these must be at least as stringent as the NAAQS. The six pollutants assigned limiting criteria under the NAAQS, referred to as the “criteria” pollutants, include:

- Carbon monoxide (CO)
- Lead (Pb)
- Nitrogen dioxide (NO₂), including the family of mono-nitrogen oxides (NO_x, i.e., NO and NO₂)
- Ozone (O₃)
- Particle pollution, including:
 - Inhalable Course Particles (PM₁₀) (particles with a diameter of 10 micrometers or smaller)
 - Fine particles (PM_{2.5}) (particles with a diameter of 2.5 micrometers or smaller)

- Sulfur dioxide (SO₂), including the family of sulfur oxides formed when fuel containing sulfur oxide is burned

The NAAQS and the Alaska Ambient Air Quality Standards (AAAQS) valid at the time this document was prepared are summarized in the Liberty EIA, Table 3.4-1 (Hilcorp, 2015, Appendix A, Section 3.4, Table 3.4-1).

Standards for each of the criteria pollutants (referred to as “indicators”), are comprised of several elements, including limiting criteria, which are associated with one or more unique “averaging times,” where the frequency of occurrence is limited by the “form” of each standard. Every five years the EPA reviews each standard, and if necessary revises them. Thus, periodic reviews may result in the designation of new limiting criteria, updated averaging times, or revised forms for compliance.

The four elements of a standard are:

- Indicators - The six potentially harmful pollutants that are valid at the time of the preparation of this environmental review and listed above. Congress focused regulatory attention on these six pollutants because they have been found to endanger public health and the environment at certain concentrations, are widespread throughout the United States, and come from a variety of sources.
- Limiting criteria - The science-based maximum concentrations below which healthful outside (ambient) air is presumed to exist. Concentrations are expressed as the mass of pollutants per volume unit of ambient air; for instance, parts per million (ppm) or micrograms per cubic meter (µg/m³).
- Averaging time - The time periods associated uniquely with each pollutant and limiting criteria. The period of time over which concentrations of the pollutant are averaged; health effects are assumed derived from controlled human exposure studies or based on environmentally-based criteria. Averaging times may be short-term (e.g., 1-hour, 3-hour) or long-term (i.e., annual mean).
- Form - The conditions that define compliance to the NAAQS. For instance, compliance requires that the 8-hour average concentration of CO cannot exceed 9 ppm more than once per year, and the rolling 3-month average concentration of Pb cannot exceed 0.15 µg/m³ at any time. There is a published form for each standard.

In addition, there are two types of NAAQS: primary and secondary standards, where each standard, whether primary or secondary, includes an indicator, the limiting criteria, the averaging time, and form. Primary standards are established based on human health and focus on the health of sensitive populations such as asthmatics, children, and the elderly; secondary standards are based on public welfare and focus on protecting the environment, preventing property damage, protecting against decreased visibility, and preventing damage to animals, crops, vegetation, and buildings. While some NAAQS have separate and distinct primary and secondary standards, other NAAQS are assigned a single value for both types. Some NAAQS have no established secondary standard, but all NAAQS have at least a primary standard.

The EPA demarcates air quality control regions (AQCRs) that define geographical areas of homogeneous air quality characteristics and then designates the areas as nonattainment or attainment relative to each of the NAAQS. The AQCRs are not sensitive to city, county, or state boundaries. The AQCRs are designated by the EPA pursuant to Sec. 107 of the CAA (42 U.S.C. § 7407) and are listed in 40 CFR part 81.

If pollutants exceed any of the NAAQS or contribute to NAAQS non-compliance in a nearby onshore area, relative to either primary or secondary standards, EPA may designate the AQCR as a “nonattainment area.” An AQCR is designated “attainment,” for specific pollutants in areas where a

pollutant does not exceed either a primary or secondary NAAQS. An area may be designated nonattainment for one standard and attainment for another over the same geographical area.

The EPA further categorizes attainment areas into Class I, Class II, and Class III Areas. Class I Areas, which are defined in the CAA as federally owned land for which Air Quality-Related Values (AQRV) are highly prized. Within Class I Areas no diminution of air quality, including visibility, will be tolerated. Less rigorous requirements are established for Class II Areas, and even less structure is required for Class III attainment areas. There are currently no Class III areas in the US, and areas that are not designated as Class I areas are by default designated as Class II areas. The EPA recommends any proposed new or modified source of emissions located within 100 kilometers (62 mi) of a Class I area should be evaluated for potential adverse air quality or AQRV impacts on the Class I Area. This regulatory framework is intended to ensure that new or modified emission sources do not cause or contribute to exceedances of the NAAQS, nor adversely impact AQRVs in Class I areas.

The air quality status within an AQCR applies only to onshore areas, as the EPA does not classify the quality of air above the OCS. Compliance to the NAAQS is the responsibility of the state for the atmosphere above state waters extending from the shoreline to the seaward boundary, which in Alaska is three nautical miles (nm) (5.6 km) beyond the shoreline. BOEM is responsible for the control of OCS sources of air emissions proposed for the Beaufort Sea OCS Planning Area extending beyond the seaward boundary to include all Federal waters of the OCS outward to 200 nm (370 km).

Air quality, as referred to in an environmental review prepared under NEPA, describes the characteristics of the atmosphere within 6 to 10 feet of ground level (where people breathe) based on the cleanliness of the air relative to established standards. On a geographic scale, and having no natural boundaries, air quality is assessed relative to local sources of pollutants that have both local and regional areas of effect, and in the case of greenhouse gases (GHGs), a global effect. The affected environment is assessed by determining the current status of local air quality of onshore areas adjacent to the Beaufort Sea OCS Planning Area, and examining the sources of regulated pollutants already present in the Proposed Action Area.

3.1.5.1. Attainment Status

The current status of onshore air quality adjacent to the Beaufort Sea OCS Planning Areas is designated by the EPA as unclassifiable/attainment. Also, there is no Class I Area within 100 kilometers (62 mi) of the Alaska North Slope (ANS).

3.1.5.2. Jurisdictional Authority for Air Pollution Control

Air pollution prevention and control of new or modified sources within the Beaufort Sea OCS Planning Area is regulated by the Department of the Interior, and by delegation, the Alaska BOEM OCS Regional Office, under 30 CFR part 550, primarily subparts B and C, as prescribed under the OCS Lands Act (OCSLA) § (5)(a)(8) (42 U.S.C. § 7401 et seq.).

The BOEM OCS air regulations require controls on new and modified OCS sources only when activities authorized under OCSLA have the potential to significantly affect the air quality of any State, and includes the requirement for compliance with the NAAQS pursuant to the CAA. The regulations apply to all proposed new and modified OCS sources, unless specifically exempted under 30 CFR § 550.303(d). The regulations may require compliance to the EPA Significant Impact Levels (SILs) (40 CFR § 51.165(b)(2)) and the EPA Prevention of Significant Deterioration (PSD) levels (40 CFR § 52.21(c)). The BOEM regulation is further dependent on the air quality attainment status of the affected onshore area.

3.1.5.3. Existing Emissions

Emission sources likely responsible for existing air quality conditions are related to current levels of onshore and offshore industry. The existing sources of pollutants adjacent to the Beaufort Sea OCS Planning Area vary considerably in quantity and type. There are relatively few offshore and onshore sources on and near the Alaska North Slope (ANS). Most are associated with the operation of the Prudhoe Bay oil field and the several relatively small villages located along the coast of the ANS. Existing annual emissions onshore and offshore along the ANS are summarized in Table 3.1.5-1.

Table 3.1.5-1. Existing Emissions (Tons per Year).

Pollutant	Offshore	Onshore	Total
NO _x	1,816	45,734	47,550
SO ₂	38	1,235	1,273
VOC	106	2,886	2,992
CO	249	14,002	14,251
PM ₁₀	36	35,644	35,680
PM _{2.5}	27	4,771	4,780
Pb	0.005	0.325	0.330
CO _{2e}	141,933	13,796,135	13,938,067
HAP	18	390	408
H ₂ S	0.0	196	16
NH ₃	0.7	4.4	5.2

Source: Fields, Billings, and Pring et al. (2014, Table VI-1).

3.1.5.4. Arctic Haze

Air quality on the Alaska North Slope can be affected by a phenomena referred to as “Arctic haze.” Arctic haze is most frequently visible during the winter and spring months and is the result of the long-range transport of pollution mainly from coal-burning power plants in the Eurasian midlatitude countries of Russia and China. The poleward transport of the aerosols from Eurasia occurs under the influence of high pressure systems causing the aerosols to be concentrated within the lower 10,000 feet of the atmosphere in the same general location each year. The haze is comprised of aerosols such as smoke, particle matter, sulfates, and black carbon, all of a diameter generally less than 1.0 micrometer in diameter, and trace gas pollutants such as ozone. The aerosols may have a regional effect on climate change because they increase the number and concentration of cloud droplets. Zhao and Garret (2014) found that in Utqiagvik, Alaska, the net radiative effect of clouds is to warm the surface during all months except June through September. They also found the average indirect warming effects from the aerosols over the Arctic to be modest because the clouds are present and polluted only one quarter of the time.

3.1.6. Climate Change

Climate change in the context of this DEIS is defined as the unusually rapid change in the Earth’s average (or net) surface temperature over the past century, which is primarily due to greenhouse gases (GHGs) released from the burning of fossil fuels. Although the Earth’s climate is naturally variable, the current concern with global climate focuses on how this change is accelerating.

Fluctuations in the global climate are the consequence of the Earth’s energy budget (radiation balance), which is the system of heat transfer between the Earth and the Sun; a natural process that seeks equilibrium (NASA, 2016). When the system’s natural radiation-balance is modified by excess GHGs in the atmosphere, an acceleration of net warming occurs.

The International Panel on Climate Change (IPCC) released its Fifth Assessment Report (AR5) in 2013, providing updates with respect to global climate change. Scientific publications on climate change impacts, adaptations, and vulnerabilities doubled between 2005 and 2010. While the science of climate modeling is evolving, scientists generally agree the warming trend is accelerating at a

remarkable rate, which is, at least in part, the result of increased emissions of GHGs produced by human activities (IPCC, 2013). The United Nations Framework Convention on Climate Change (UNFCCC) suggests that climate change is attributable to human activities that have altered atmospheric composition and caused climate variability beyond what can be explained by natural causes; the IPCC explains that recent climate changes cannot be explained by natural causes alone, and that it is likely that human activities have been the dominant cause of warming (IPCC, 2013). Not yet apparent are the impacts to many biological systems, as many impacts are still within natural high variability, and may be further influenced by confounding local and regional factors (IPCC, 2013); however, the scientific confidence that these changes will occur is high.

3.1.6.1. Greenhouse Gases

GHGs are chemical compounds that contribute to the greenhouse effect by absorbing infrared radiation from the sun. When an overabundance of GHG is present in the lower atmosphere, more heat can be trapped, and the net temperature of the earth increases. Some GHGs, such as CO₂, are emitted to the atmosphere both through human activities and natural processes. Other GHGs are created and emitted solely through human activities. The three most abundant GHGs caused by human activities are:

Carbon dioxide (CO₂). CO₂ enters the atmosphere through the burning of fossil fuels (oil, natural gas, and coal), solid waste, trees and wood products, and also as a result of other chemical reactions. CO₂ is removed from the atmosphere when it is absorbed by plants as part of the biological carbon cycles (EPA, 2011d). Concentrations of CO₂ have increased steadily since the beginning of the industrial era, from an annual average of 280,000 parts per billion (by volume) (ppbv) in the late 1700s to 396,000 ppbv, or 0.0396%, at Mauna Loa Observatory in 2013 (EPA, 2014d). CO₂ is not destroyed in the atmosphere over time; some molecules may remain in the atmosphere for 50 to 500 years. The graphs in Figure 3.1.6-1 depict recent increases in CO₂ emissions.

Methane (CH₄). The warming impact from emissions per pound of CH₄ is over 20 times greater than CO₂ (EPA, 2014a). CH₄ is emitted during the production and transport of coal, natural gas, and oil. CH₄ emissions also result from livestock and other agricultural practices and by the decay of organic waste in municipal solid waste landfills (EPA, 2011c). Concentrations of CH₄ have more than doubled since preindustrial times, primarily due to the use of fossil fuels; CH₄ concentrations were measured at 1,800 ppbv, or 0.00018%, in 2013 (EPA, 2014d). Methane remains in the atmosphere for an average of 12 years.

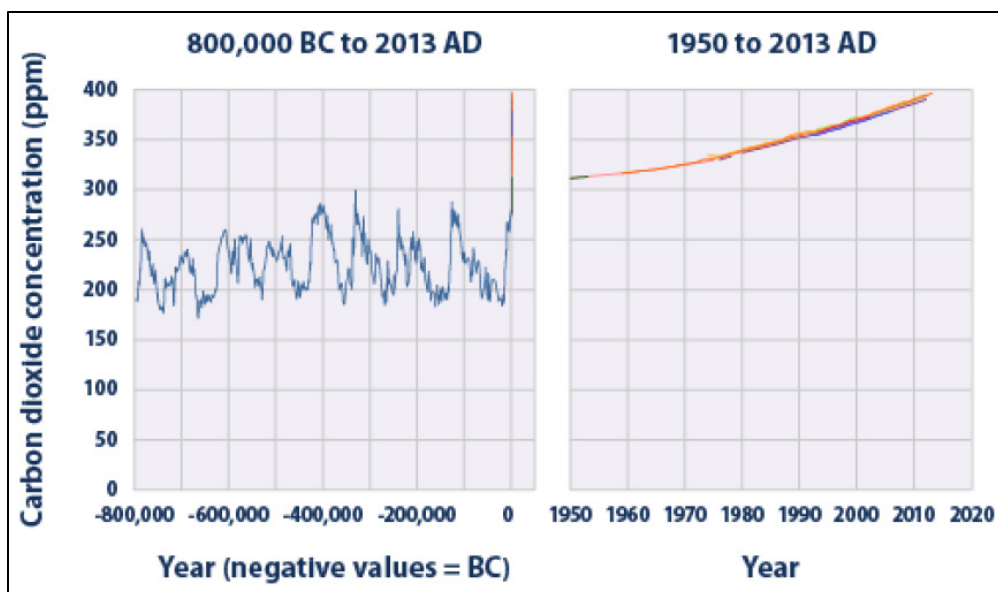

Figure 3.1.6-1. Global Atmospheric Concentrations of Carbon Dioxide over Time. These graphs show the concentrations of CO_2 in the earth's atmosphere dating back hundreds of thousands of years through 2013, measured in parts per million (ppm). The graph on the right shows the increase of CO_2 emissions in the past 63 years until 2013. Source: EPA (2014d).

Nitrous oxide (N_2O). The impact of one pound of N_2O is over 300 times that of one pound of CO_2 with respect to the ability to absorb heat (and thus retain it in the atmosphere) (EPA, 2014a). N_2O is emitted during agricultural and industrial activities, as well as during combustion of fossil fuels and solid waste (EPA, 2011d). After rarely exceeding 280 ppbv over the last 800,000 years, levels of N_2O have increased since the 1920s to a new high of 326 ppbv, or $3.2\text{E}-5\%$, due primarily to agriculture (EPA, 2014d). Nitrous oxide molecules remain in the atmosphere for an average of 120 years, until transformed through chemical reactions.

3.1.6.2. Systems Driving Global Climate Change

Climate zones are controlled by various topographical, oceanographic, and meteorological features (Ahrens, 2013). These features include intensity of sunshine (which can vary by latitude), distribution of land and water, ocean currents, prevailing winds, high-and low-pressure areas, mountain barriers, and altitude. The natural fluctuations of these systems can have an impact on the climate, both locally and on the global scale.

The Pacific Decadal Oscillation (PDO), the North Atlantic Oscillation (NAO), and the Arctic Oscillation (AO) are all patterns of climate variability that are believed to influence global and Arctic climate. Figure 3.1.6-5 illustrates the AO from 1950 through 2014. The PDO describes the fluctuation in northern Pacific sea surface temperatures that alternate between above normal (negative phase) and below normal (positive phase). These cycles operate on a 20- to 30-year time scale (NOAA, 2011), and are believed to be associated with shifts in the climate of the North Pacific around 1948 and 1976 (Bond, 2011). The last major shift in the PDO occurred in 1976-1977, marking a change from cold to warm conditions in Alaskan waters (Bond, 2011).

The NAO is a climate system that is the dominant mode of winter climate variability for a geographic area extending from the North Atlantic region to central North America, Europe, and Northern Asia. The NAO is a large-scale atmospheric mass that controls the strength and direction of the westerly winds and storm tracks across the North Atlantic. A positive NAO index is associated with stronger and more frequent winter storms crossing the Atlantic Ocean. The NAO has trended toward the

positive phase over the past 30 years (Bell, 2011), which is associated with stronger and more frequent winter storms crossing the Atlantic Ocean.

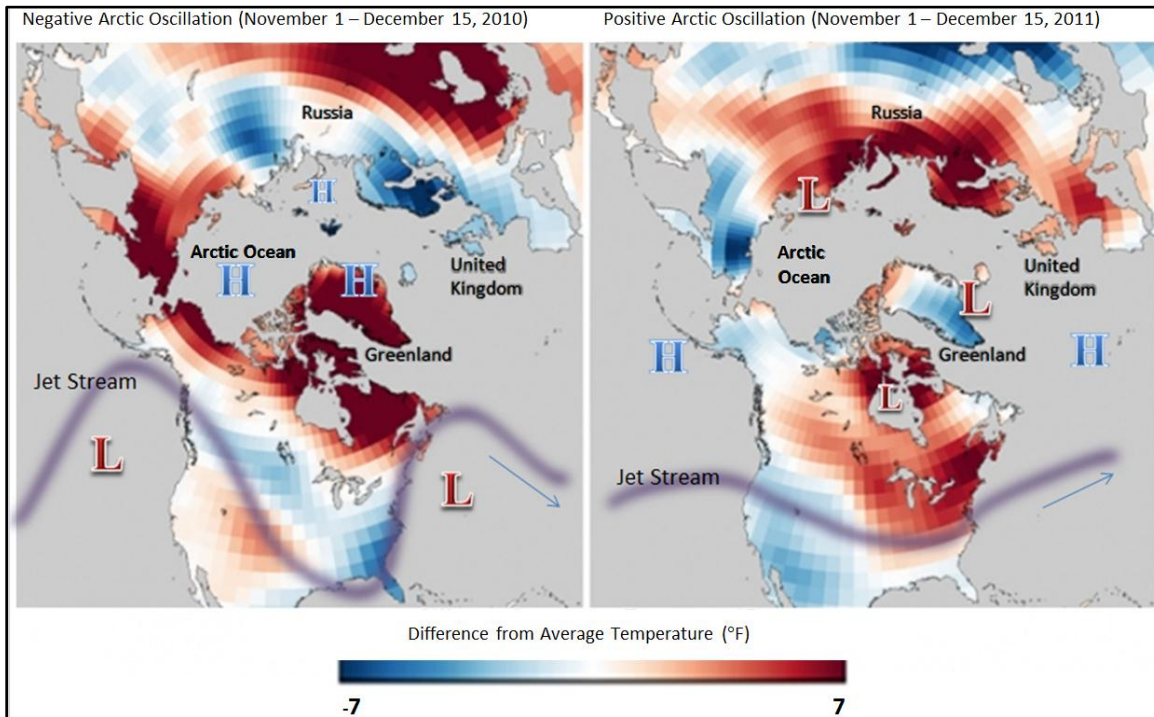

Figure 3.1.6-2. Arctic Oscillation Phases. This diagram shows the approximate average locations of high and low pressure centers and the jet stream location that define the negative and positive phases of the Arctic Oscillation, superimposed on a world temperature map of 2010 and 2011. The positive phase shows low pressure over the polar region and higher pressure in the Northern Pacific and Northern Atlantic Oceans. When shifting to the negative phase, the winds become weaker, and the jet stream develops a deep trough over the central United States, allowing cold air to drive southward. (Douglas, 2012). Sources: Adapted by BOEM from Douglas (2012).

The AO is a climate cycle system that influences climate patterns in the Arctic. The AO is very similar to the NAO with respect to timing and effects on local temperatures and precipitation. The AO is defined by the location of synoptic surface pressure patterns (highs and lows) at the polar and middle latitudes that, on occasion, nearly reverse position, and “oscillate” between positive and negative phases from one winter to the next.

Graphs of the historical occurrence of the annual AO index, whether positive or negative, are shown in Figure 3.1.6-2. On the graphs, the positive phases of the AO are indicated by marks above the zero-line, and the negative phases, below the line. Since 1950’s, the AO has fluctuated between the negative and positive phases, being mostly negative through the 1990s, when a more intense positive phase prevailed. During the 2000s, the AO has fluctuated, having a more intense negative phase in 2010, followed by another positive phase. The AO can change from a positive to negative mode, or vice versa, in a matter of weeks. The increase in incidence of the AO negative phase supports continued warming in the Arctic Ocean and Alaska (NASA, 2011).

Global Temperature

Scientists began to derive equations in the 1860’s that are still used to calculate how changes in the levels of carbon dioxide in the atmosphere can alter the surface temperature through the greenhouse effect. The greenhouse effect is the process by which radiation from a planet’s atmosphere warms the planet’s surface to a temperature above what it would be without its atmosphere (IPCC, 2013).

Evidence from ice-core data from Antarctica has been used to determine the historical record of temperature versus the concentration of carbon dioxide from 420,000 years ago to present, as depicted in Figure 3.1.6-3. The core analyses from which this figure's data was derived shows that CO₂ and CH₄ concentrations correlate with the Antarctic isotopic temperature (Petit, Jouzel, and Raynaud et al., 1999).

The figure below illustrates that in the past, the main trends of CO₂ concentration and temperature changes are similar for each glacial cycle. The last ice age ended approximately 7000 years ago, marking the beginning of the current climate era and the onset of human civilization. Most climate changes are attributed to very small variations in Earth's orbit that change the amount of solar energy the planet receives (IPCC, 2013).

The notable spike in CO₂ shows that present-day atmospheric burden of CO₂ is unprecedented during the past 420,000 years (Petit, Jouzel, and Raynaud et al., 1999) and of particular significance since it is very likely human-induced (IPCC, 2013).

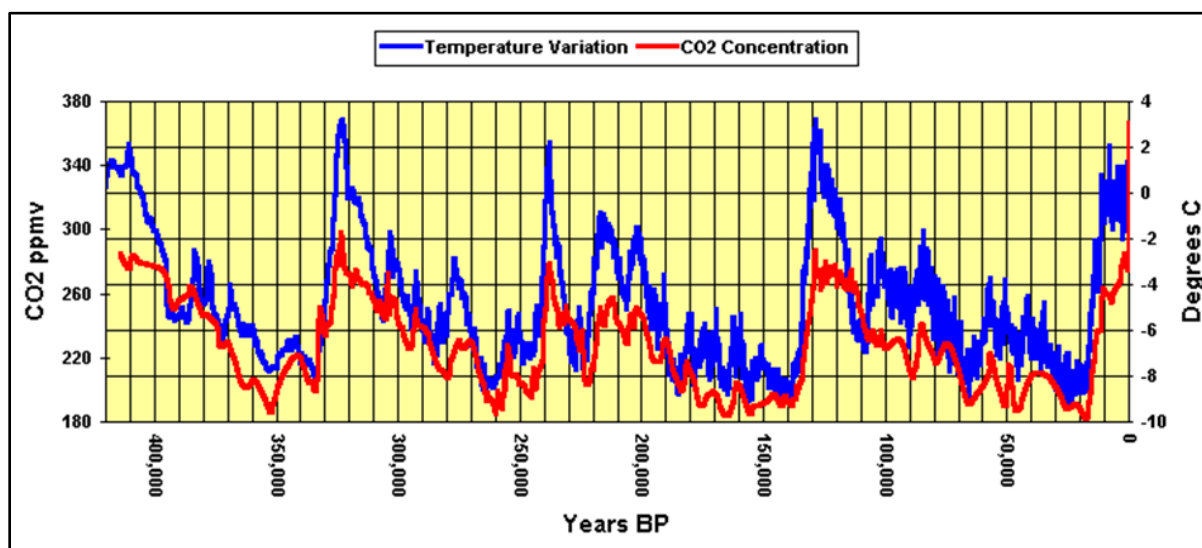

Figure 3.1.6-3. Chronological Temperature and CO₂ Concentrations. *This image reflects results from ice-core data collected from the Vostok site in Antarctica and published in the British journal, Nature. The graph shows the correlation between CO₂ concentration levels, over time, and temperature changes through four glacial cycles dating back 420,000 years. The graph measures the concentration of CO₂, in units of parts per million by volume (ppmv) against temperature in degrees Celsius, against the years “before present” (B.P.) in demarcations of 10,000 years. The thicker lines of temperature beginning approximately 100,000 B.P. are the result of more copious data than was available for the previous periods. Source: Petit et al. (1999).*

The U.S. Global Change Research Program (USGCRP) estimated that increases in average global temperatures are expected to be within the range of 0.5°F to 8.6°F by 2100, with a likely increase of at least 2.7°F for all scenarios except the one representing the most aggressive mitigation of greenhouse gas emissions. Except under the most aggressive mitigation scenario studied, global average temperature is expected to warm at least twice as much in the next 100 years as it has during the last 100 years. Ground-level air temperatures are expected to continue to warm more rapidly over land than oceans. Some parts of the world are projected to see larger temperature increases than the global average (USGCRP, 2014). By 2100, the average U.S. temperature is projected to increase by about 3°F to 12°F, depending on emissions scenario and climate model. An increase in average temperatures worldwide implies more frequent and intense extreme heat events, or heat waves. The number of days with high temperatures above 90°F is expected to increase throughout the United States, especially toward the end of the century. Climate models project that if global emissions of greenhouse gases continue to grow, summertime temperatures in the United States that ranked among

the hottest 5% in 1950-1979 will occur at least 70% of the time by 2035-2064 (IPCC, 2013). Figure 3.1.6-4 illustrates the IPCC (2013) modelling.

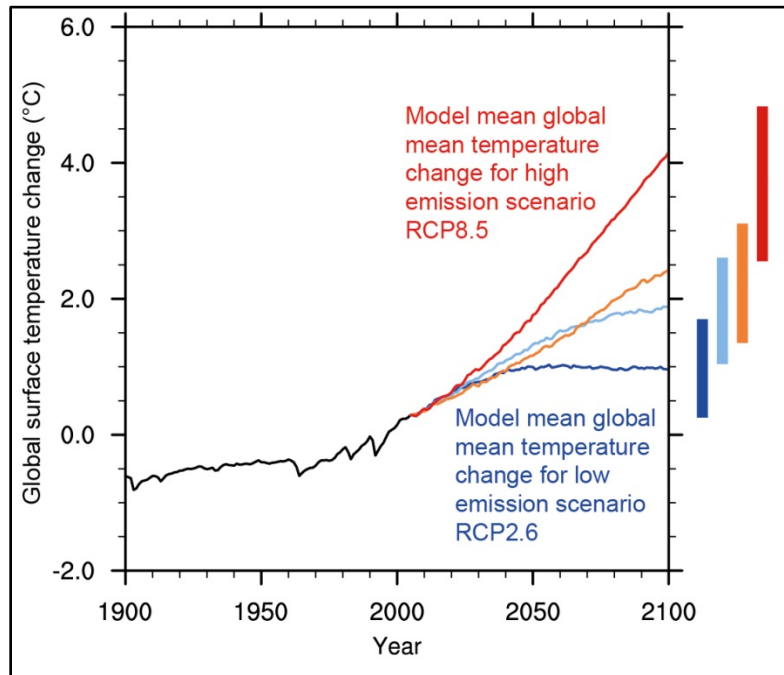

Figure 3.1.6-4. Observed and Projected Changes in Global Average Temperature. *Observed and projected changes in global average temperature under four emissions pathways. The vertical bars at right show likely ranges in temperature by the end of the century, while the lines show projections averaged across a range of climate models. Changes are relative to the 1986-2005 average. Source: IPCC (2013).*

Sea Level Rise

The global sea level has risen and fallen by approximately 400 ft in the past four glacial cycles (since approximately 400,000 years ago) (Siddall et al., 2003). The global sea level rise in the last century is approximately 6.7 – 7.5 inches (USGCRP, 2014) (IPCC, 2013). Since 1992, satellite altimeters indicate that the rate of rise has increased to 1.2 inches per decade—a significantly larger rate than at any other time over the last 2,000 years (NOAA, 2016).

An increase in the global net temperature contributes to sea level rise by expanding the ocean water (by increasing the net temperature of the seawater), melting mountain glaciers and polar ice caps, and causing portions of Greenland and Antarctic ice sheets to melt into the ocean.

Ocean Acidification

The oceans are natural reservoirs of inorganic carbon. About 30% of the total anthropogenic emissions of CO₂ accumulate in the ocean, which is resulting in gradual increased acidification. This additional CO₂ and corresponding decrease in ocean pH levels increases potential threats to the health of the world's oceans ecosystems (IPCC, 2013).

Seawater that is supersaturated with calcium carbonate minerals typically supports abundant healthy marine life. Calcium carbonate minerals provide the means for calcifying organisms to build their skeletons and shells. Continued ocean acidification would cause some parts of the ocean to become less saturated with the needed mineral, which is likely to affect the ability of some organisms to produce and maintain their shells (NOAA, 2014b). See Section 3.1.4, Water Quality, for additional detail on ocean acidification.

Polar Ice Conditions

Data from NASA's Gravity Recovery and Climate Experiment show Greenland lost 150 to 250 cubic kilometers (36 to 60 cubic miles) of ice per year between 2002 and 2006, while Antarctica lost about 152 cubic kilometers (36 cubic miles) of ice between 2002 and 2005.

3.1.6.3. Climate Change in the Arctic

The climate is changing faster in the Arctic than any other region in the world (NOAA, 2014a). Temperature recordings taken by the National Weather Service Office in Utqiagvik from 1961 through 2010 and compiled by the Western Regional Climate Center in Reno, Nevada provide evidence of the warming in the Arctic (WRCC, 2014). The temperature recordings show that Utqiagvik's mean temperature increased from 9.4°F/-12.6°C during the 30 years from 1961-1990, to 11.8°F/-11.2°C during the 30 years from 1981-2010, an increase of 2.4°F/1.4°C (Figure 3.1.6-5)

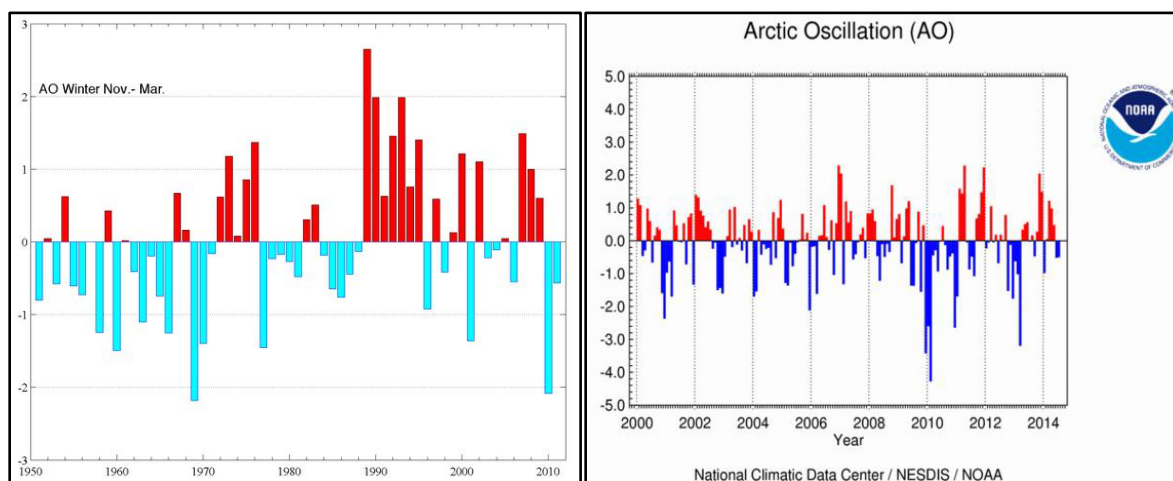

Figure 3.1.6-5. Chronological Arctic Oscillation Phases. The charts show the changes in the AO beginning in 1950 until 2010 (left) and in the decade of the 2000s (right). Source: NOAA, 2014b.

Evidence of the Arctic climate warming is also supported by traditional knowledge from Alaska Native communities along the Beaufort and Chukchi Seas. The IPCC noted that evidence of climate change is more apparent in natural systems, notably global warming, shifts in precipitation patterns and ocean acidification (IPCC, 2013). Residents of these communities have reported changes in thickness of sea-ice, increased snowfall, drier summers and falls, warmer temperatures, reduced river and lake ice, permafrost degradation, and increased storms and coastal erosion. Changes reported by local residents are generally consistent with the scientific evidence of climate change (NSIDC, 2011):

- Air temperatures in the Arctic are increasing at an accelerated rate
- Year-round sea-ice extent and thickness has continually decreased over the past three decades
- Water temperatures in the Arctic Ocean have increased
- Changes in salinity of the Arctic Ocean has occurred
- Sea levels are rising
- Glaciers are retreating
- Terrestrial precipitation is increasing
- Permafrost is warming
- The tree line is migrating northward

Although verifying such trends in the Arctic is challenging due to the small number of monitoring stations and relatively short records of data, the following statistics for the Arctic, published as part of the Arctic Climate Impact Assessment, support these trends (ACIA, 2004 and ACIA, 2005):

- A warming trend in the Arctic of 0.160°F/0.089°C per decade compared to 0.110°F/0.061°C, per decade, for the globe
- A warming trend of 0.70°F/0.389°C per decade over last four decades
- Precipitation increase of approximately 1% per decade over the past century
- Snow extent decrease of approximately 10%
- Permafrost warming almost 3.6°F/1.45°C over the past three decades
- A rise in Arctic Sea level of 10 to 20 centimeters (cm) (3.9-7.9 in) in the past century
- An 8% decrease in annual average sea-ice extent over the past three decades
- A 15% to 20% decrease in the extent of summer sea ice over the past three decades
- A mean annual increase in temperatures of 4-5°F/2-3°C over the last 50 years
- A decrease in sea-ice thickness by 42% since the middle 1970s
- An increase in winter temperatures of 6-7°F/ 3-4°C over the past 50 years

Changes in the Arctic climate are illustrated in reductions in sea ice over the past several decades. According to the National Aeronautics and Space Administration (NASA), the annual minimum summer extent of Arctic ice coverage in September 2013 was 1.97 million (M) mi² (5.10M km²). The extent of sea ice varies from year to year; for example, the 2012 annual minimum summer extent was 1.32M mi²/3.41M km², about half the size of the average minimum extent from 1981 to 2010. According to NASA:

“The trend with decreasing sea ice is having a high-pressure area in the center of the Arctic, which compresses the ice pack into a smaller area and also results in clear skies, which enhances melting due to the sun.” Further, “(t)he character of the ice is fundamentally different: It's thinner, more broken up, and thus more susceptible to melt completely. This year [2013], the cool temperatures saved more of the ice. However, the fact that as much of the ice melted as it did is an indication of how much the ice cover had changed. If we had this weather with the sea ice of 20 years ago we would have had an above-normal extent this year [2013]” (NASA, 2013).

Because thinner ice melts faster than thicker ice, the average thickness of Arctic ice is expected to decrease further, particularly the extent of the summer ice. NASA predicts that at this rate, Arctic summer ice may disappear completely within this century (NASA, 2013).

Continued loss of sea ice could cause further warming through albedo feedback. Albedo feedback occurs when a change in the area of snow-covered land, ice caps, glaciers, or sea ice alters the reflectivity of a surface. Albedo (\hat{I}) is a value that indicates the reflective ability of a surface from 0 to 1. Generally, the whiter the surface, the more reflective it is, and the value tends toward 1; conversely, the darker the surface, the less reflective it is, and the value tends toward 0. Cooling increases ice coverage and increases the albedo. Increased albedo leads to increased cooling as the amount of solar energy absorbed is minimized. Conversely, decreased albedo leads to increased warming as the amount of solar energy absorbed is maximized (Deser, Walsh, and Timlin, 2000).

In the warming Arctic climate, this feedback loop has the potential to:

- Increase sea levels; alter the salinity of the Arctic marine environment, including the Beaufort Sea (NASA, 2013)

- Cause an increased release of methane (CH₄) into the atmosphere due to melting of permafrost
- Increase storm tracks, patterns of precipitation, and the frequency and severity of cold-air outbreaks in middle latitudes (ACIA, 2005).

Table 3.1.6-1 shows comparisons of the albedo values for three surfaces.

Table 3.1.6-1. Ice-Albedo Comparisons.

Surface	Cooling (î±, percent reflected)	Heating (percent absorbed)
Ice	50%	50%
Snow covering ice	90%	10%
Open Ocean	6%	94%

Source: NSIDC, 2014b.

Soot, or Black Carbon (BC), plays a role in short-term climate effects in the Arctic. The particles that comprise BC are created by the combustion of fossil fuels and by forest fires. BC particles can originate in other countries and be transported to the Arctic. The dark color of the particles decreases albedo after deposition on the ice and snow, causing incoming radiation to be absorbed. Unlike GHGs, the particles of BC are short-lived in the atmosphere, with a lifetime of days to weeks. There is a “cloud” of BC that occurs over the Arctic from early winter until springtime. Climate effects from black carbon are especially strong in sensitive areas such as the Arctic, resulting in earlier annual spring melting and sea-ice decline. The visual effect of BC also makes the impacts more immediately recognizable than impacts from GHGs.

The greatest degree of ocean acidification worldwide is predicted to occur in the Arctic Ocean. This is due to the effects of increased freshwater input from melting snow and ice and from increased CO₂ uptake by the sea as a result of ice retreat (Fabry et al., 2009). Measurements in the Canada Basin of the Arctic Ocean demonstrate that over 11 years, melting sea ice forced changes in pH and the inorganic carbon equilibrium, resulting in decreased saturation of calcium carbonate in the seawater (Yamamoto-Kawai, 2009).

3.2. Biological Environment

3.2.1. Lower Trophic Level Organisms

The lower trophic organisms living within the Beaufort Sea OCS consist of three diverse and abundant groups (Hopcroft et al., 2008). These are the pelagic, the epontic, and the benthic organisms.

3.2.1.1. Pelagic Communities

The pelagic communities are comprised primarily of two groups living at the surface and near-surface levels, the phytoplankton and zooplankton. Phytoplankton are the one-celled algae adapted to living in the photic zone (the upper areas where light adequate for phytoplankton penetrates the water) in the upper layers of the ocean surface. Within Arctic waters, the combination of cold temperature, sea ice, and seasonal fluctuations in light regimes creates variation in the timing and extent of seasonal blooms. Phytoplankton blooms (including concurrent zooplankton organisms) tend to occur in two separate events of early and late summer, generally from July to August. The density and duration of the blooms are dependent upon weather conditions and nutrient fluxes (Horner and Schrader, 1982). Zooplankton consist of permanent residents of the planktonic mass such as copepods, and animals exhibiting complex life cycles that include a developmental stage within the spring plankton blooms such as the larvae of fish, crustaceans, barnacles, polychaetes, and mollusks (Hopcroft et al., 2008). The pelagic expanses between the surface and the benthic realms support diverse and abundant populations, including the larvaceans, pteropods, ctenophores, jellyfish, salps, squid, and other invertebrate organisms that contribute to the productivity of the region (Hopcroft et al., 2008).

3.2.1.2. Epontic Communities

The epontic organisms are the ice-dwellers, or organisms that live on or in the matrix of the ice (Gradinger, Bluhm, and Iken, 2010). These organisms include the ice algae, amphipods, nematodes, polychaetes, and euphausiids (Hopcroft et al., 2008). Ice algae blooms are essential to the primary productivity of the region (Horner and Schrader, 1982) and other epontic organisms are important contributors to the food web (Bradstreet and Cross, 1982). Relative to ice-covered and break-up months, the ice-associated organisms listed previously are not present in high abundances in the open water and early ice-up seasons.

3.2.1.3. Benthic Communities

The final group are the benthic organisms, consisting of groups living within the upper sedimentary matrix (infaunal organisms) and those living on or just above the benthic surface, or strongly associated with the benthic surface (epifaunal organisms). Offshore benthic communities can be quite diverse, but organisms commonly found in surveys include echinoderms, sipunculids, mollusks, polychaetes, copepods, sponges, corals, and amphipods (Dunton, Schonberg, and McTigue, 2009; Rand and Logerwell, 2011).

Most seafloor substrates on the Beaufort Sea OCS consist of aggregations of fine sands, muds, and silts, with percentages of substrate consisting of mud ranging from 17% to 84% (USDOI, BOEM, 2010). Site-specific geotechnical information is available through HAK's proprietary Geotechnical Report (File folder 236, 3A). Limited extents of scattered cobblestone or pebbles may be found at shallower depths (Dunton, Schonberg, and McTigue, 2009). A focus on differences in communities based on physical factors is addressed in the BOEMRE-sponsored cANIMIDA studies on hydrocarbon chemistry and substrate composition (USDOI, BOEM, 2010), and the 2006 Final Seismic Programmatic Environmental Assessment.

The Boulder Patch (Figure 3.1.1-1) is an area within Stefansson Sound generally defined by having a greater than 10% cover of small boulders and cobblestone on the benthic surface (Martin and Gallaway, 1994). This hard bottom benthic surface supports the richest and most diverse biological communities known in the Beaufort Sea (Dunton, Reimnitz, and Schonberg, 1982). These hard bottom surfaces were discovered by USGS marine geologists looking for evidence of oil-rich geological formations during the summers of 1971 and 1972 (Reimnitz and Ross, 1979). Biological surveys in the late 1970s and early 1980s confirmed the existence of benthic substrates consisting of cobble and boulders while discovering diverse epilithic communities of large kelp (such as *Laminaria solidungula*) and corals (such as *Gesmeria rubiformis*) growing on the rocks along with benthic communities consisting of more than 140 types of sponges, bryozoans, polychaetes, clams, snails, copepods, amphipods, cumaceans, seastar, and tunicates (Dunton and Schonberg, 2000). The kelp in the Boulder Patch is an important component of the highly diverse community, especially as a source of carbon (Dunton and Schell, 1986, Dunton and Schell, 1987). *Laminaria solidungula*, the dominant species of kelp in the Boulder Patch, is well adapted for low-light conditions; most of its annual linear growth occurs in under-ice darkness during the winter (Dunton, Reimnitz, and Schonberg, 1982; Dunton and Jodwalis, 1988). Continued studies have examined the impacts of disturbance on the Boulder Patch (Konar, 2007; Konar, 2013) as well as characterizations of the community assemblages (Dunton, Reimnitz, and Schonberg, 1982; Dunton and Schonberg, 2000; Konar and Iken, 2005; Wilce and Dunton, 2014). Although the exact size of the Boulder Patch is unknown, current knowledge indicates that it is a relatively small area of high benthic diversity in a larger region affected by frequent seasonal perturbations.

Climate Change

Due to climate change processes described in Section 3.1.6, such as ocean acidification, global temperature, and polar ice conditions, the current communities of lower trophic organisms are

expected to change throughout the life of the project. Impacts on lower trophic level organisms include direct synergistic impacts such as changes in the timing and magnitude of plankton blooms, physiological changes from altered ocean pH and temperature, and habitat modification that could occur as a result of melting ice, shoreline erosion, and sea level rise. A primary impact of ocean acidification is that it depletes seawater of the carbonate compounds—aragonite and calcite—that many marine creatures need to build shells and skeletons (Fabry et al., 2008). As a result, ocean acidification hinders organisms such as corals, crabs, seastars, sea urchins and plankton from building the protective armor they need to survive. Rising acidity also affects the basic functions of fish, squid, invertebrates, and other marine species, including detrimental effects on metabolism, and respiration, which can thwart their growth and lead to higher mortality (Fabry et al., 2008). In addition, ocean acidification has the potential to profoundly affect the growth and toxicity of phytoplankton associated with harmful algae blooms (HABs) (Tatters, Fu, and Hutchins, 2012; Fu, Tatters, and Hutchins, 2012). These impacts can have far-reaching effects on the structure of the food web, with some predators forced to eat non-optimal prey items. Habitat modification will expand the range for some species, while reducing it for others. In addition, the decrease of the extent of the Arctic ice pack impacts the epontic community, and subsequently, the pelagic and benthic communities. Warming ocean temperatures associated with climate change may increase all types of plankton growth rates and generation times in the region of the Proposed Action, and change the composition of lower trophic populations as warmer seas, open water and increased radiative energy from the sun increases.

3.2.2. Fish

3.2.2.1. Aquatic Environment

Fish occupy a variety of habitats in the U.S. Beaufort Sea, including marine, brackish (mix of fresh water and saltwater), and freshwater areas. They are an important link in the food web. The Proposed Action Area is home to marine, diadromous (life cycle includes both marine and freshwater components), and nearshore freshwater fishes (Craig, 1984; Craig and Haldorson, 1986; Logerwell et al., 2015).

3.2.2.2. Fish in the Proposed Action Area

Fishes known to occur frequently in the Proposed Action Area include:

Cods

Arctic cod and saffron cod are both found in the Proposed Area. Arctic cod is widely distributed throughout the U.S. Arctic, including the pelagic (in the open water column), demersal (near the seafloor), and nearshore environments of the Beaufort Sea. The absolute numbers of Arctic cod and their biomass is one of the highest of any finfish in the region (Logerwell et al., 2011; Frost and Lowry, 1983). Many species of vertebrates depend on Arctic cod as a major food source (Pirtle and Mueter, 2011). The abundance, wide distribution and the role in the food web of the Arctic cod in the Beaufort Sea make this species very important in the overall ecosystem of the U.S. Arctic region.

Arctic cod. Arctic cod move and feed in different groupings – as dispersed individuals, in schools, and in huge shoals. These distribution patterns appear to be dependent on several interacting factors including season, presence or absence of ice, salinity, water temperature, surface wind, currents, length of daylight, and the underside texture of ice. Inter-annual variation also plays a role in the pattern of distributions (Welch, Crawford, and Hop, 1993; Benoit et al., 2010).

The various life stages of Arctic cod occur across a broad range of habitats. Arctic cod migrate between offshore and inshore areas for seasonal spawning and spawn under the ice during winter (Craig et al., 1982; Craig, 1984; Bradstreet et al., 1986). Arctic cod eggs and larvae develop during late winter until early summer in the pelagic surface-water environment.

During open water, pelagic yearling and older Arctic cod were found to occur in high abundance at the continental shelf break (100 m, 328 ft), and pelagic young-of-year were found most commonly inshore (Logerwell et al., 2010). Frost and Lowry (1983) found smaller Arctic cod more often in water less than 100 meters deep. Craig et al. (1982) found adult and juvenile Arctic cod in shallow nearshore waters (1-12 m) in the Beaufort Sea in summer and winter.

Arctic cod are associated with sea ice, using it at various life stages and seasons for shelter and as a forage habitat to feed on microorganisms on the underside of the ice. Amphipods on the underside of ice are an important food source for Arctic cod (Bradstreet and Cross, 1982; Lonne and Gulliksen, 1989; Gradinger and Bluhm, 2004). Rough, irregular textures of the underside-ice may provide preferred habitat for Arctic cod to avoid predators (Crawford and Jorgenson, 1993). Gradinger and Bluhm (2004) and Lonne and Gulliksen (1989) observed and photographed Arctic cod in summer months using ice crevices and cracks on the underside of textured ice floes for escape and shelter.

Arctic cod also inhabit offshore and nearshore areas without ice during warmer times of year (Bradstreet and Cross, 1982; Bradstreet, 1982; Crawford and Jorgenson, 1993; Gradinger and Bluhm, 2004). Copepods and amphipods are common prey for Arctic cod in open water environments (Frost and Lowry, 1983; Benoit et al., 2010; Rand et al., 2013).

Saffron cod. Saffron cod occur in the Beaufort Sea primarily in nearshore waters. Unlike Arctic cod, they do not specifically associate with ice. Saffron cod move seasonally from summertime feeding offshore to inshore for spawning where they enter coastal waters and tide-influenced riverine environments. Adults and juveniles forage on the epibenthos, opportunistically taking small crustaceans and fish (Morrow, 1980; Pirtle and Mueter, 2011).

Arctic Flounder

Arctic flounder occur in the Beaufort Sea in nearshore brackish and estuarine waters, and sometimes enter freshwater rivers (Morrow, 1980; Mecklenburg et al., 2002). They exhibit seasonal movement, inhabiting offshore areas in the fall, and moving inshore at night in the spring. Spawning occurs in shallow waters from January to March in areas with strong tidal currents. Diet of Arctic flounders consists of small mollusks, crustaceans, and fish (Morrow, 1980).

Fourhorn Sculpin

Fourhorn sculpin are found in high abundance in shallow, nearshore habitats in the Beaufort Sea, and have been known to inhabit rivers (Morrow, 1980; Craig, 1984). Similarly to Arctic cod, they enter the nearshore environment when the salinity increases in late summer. Overwintering occurs in slightly brackish coastal waters under the ice. Fourhorn sculpin have been collected in the Boulder Patch. They feed on worms, amphipods, isopods, small crustaceans, fish, and eggs. Given its high abundance, the fourhorn sculpin is likely an important part of the nearshore food web, and is occasionally eaten by humans (Morrow, 1980).

Kelp snailfish

Snailfish are distributed throughout the Arctic, and kelp snailfish are commonly caught in the Beaufort Sea. They are found in nearshore areas with hard substrates and sometimes in kelp beds, such as the Boulder Patch (Walkusz et al., 2016). They feed on benthic amphipods, and are important prey for birds (Gaston, 1985) and seals (Walkusz et al., 2016).

Capelin

Capelin are a critical link in the Arctic food web. They are present in large numbers in nearshore waters of the Beaufort Sea in the summer. Spawning occurs in very shallow waters in July and August. Capelin consume primarily zooplankton, and are a forage fish species for upper trophic predators, such fish, birds, and mammals (Pirtle and Mueter, 2011).

Ninespine Stickleback

Ninespine stickleback occur in freshwater streams and brackish marine waters (Mecklenburg et al., 2002). They inhabit vegetated areas and are most often found in slower moving waters.

Overwintering occurs in deeper water, with seasonal movements in the spring to shallow, vegetated areas where spawning occurs from May to August. Nests are built in the vegetation using algae and debris, and the young are initially reared by males. Sticklebacks feed primarily on copepods, insects, worms, and small crustaceans. Although ninespine sticklebacks are not of economic importance, they are important prey items for other fish and bird species found in the Proposed Action Area (Morrow, 1980).

Salmonids

Salmonids are represented by many groups of fish that are common in the Proposed Area, including chars, whitefishes, and Pacific salmon. There are no commercial fisheries for any of these species in the Proposed Action Area, however, salmonids are an important subsistence resource.

Chars. Chars include Arctic char and Dolly Varden. These anadromous species primarily reside in freshwater rivers and lakes of the North Slope, using the nearshore marine environment as feeding grounds or as corridors to access feeding grounds (Craig and McCart, 1976). Spawning occurs from August to November in freshwater rivers or streams over gravel substrates. Arctic char and Dolly Varden overwinter in freshwater lakes and rivers, including the Sagavanirktok River. Arctic char are predators of salmonid eggs. Other food items include crustaceans, mollusks, and other fish (Morrow, 1980). For Dolly Varden, feeding occurs primarily in the nearshore, estuarine environment on small fishes, amphipods, krill, polychaetes, and other invertebrates. Little feeding is believed to occur during the overwintering period (Morrow, 1980).

Whitefish. Whitefish commonly found in the proposed area include Arctic cisco, least cisco, humpback whitefish, and broad whitefish. Whitefishes use the nearshore marine environment for feeding before returning to freshwater streams to spawn (Craig, 1984). In general, spawning occurs in the fall in streams with gravel beds. Arctic cisco spawn in the Mackenzie River and the juveniles are transported to the Alaskan Beaufort Sea through wind-driven currents (Fechhelm and Griffiths, 1990). Some riverine forms of whitefish species are known to Alaska, although the fishes found in the Proposed Area are primarily whitefish that feed in the marine environment and overwinter in freshwater environments (Craig and McCart, 1976; Craig, 1984; Morrow, 1980). Whitefish overwintering in the Sagavanirktok River were found to feed very little, despite prey availability. Broad whitefish were observed to lose weight while least cisco were found to increase mean body weight (Schmidt et al., 1989). Similar trends were observed in the Colville River (Schmidt et al., 1989). Whitefish feed on small mollusks and crustaceans (Morrow, 1980). This group of fish is commonly found in subsistence harvests.

Pacific Salmon. Pacific salmon adults and juveniles occur in the Beaufort marine environment; however, their numbers are low compared to the Bering Sea. Of the five Pacific salmon species, pink salmon and chum salmon (*Oncorhynchus gorbuscha* and *O. keta*) have been the salmon species most commonly captured in the Beaufort Sea marine and nearshore environments (Craig, 1984; Craig and Haldorson, 1986; Fechhelm, et al., 2009). In the marine environment, adult pink and chum salmon in the U.S. Beaufort Sea are known to occur down to 200 meters (660 ft) depth. As climate change occurs (ice reduction, warming waters) salmon are moving further north in greater numbers (Moss, et al., 2009; Kondzela, et al., 2009). Chum salmon and pink salmon have been documented as present in the Colville River and Colville delta area in the Alaska Department of Fish and Game (ADF&G) Anadromous Waters Catalog (Johnson and Litchfield, 2016).

Climate Change

Due to climate change processes described in Section 3.1.6, such as ocean acidification, global temperature, and polar ice conditions, the current communities of lower trophic organisms are expected to change throughout the life of the project. Climate change is likely to affect the habitat, behavior, abundance, diversity, and distribution of fish. Several studies have examined the effects of climate change (including ocean acidification) on fish. These studies emphasize the implications of potential northern range expansions of fish species, the effects of warming sea surface temperatures on fish biomass, possible changes in fish species complexes, effects on commercially important species, shifts in prey availability and shifts in food webs, and the particular vulnerability of coastal areas in Alaska (Cheung et al., 2009; Sherman et al., 2009). Shifts in the food web as a result of changing climate could result in major ripple effects on fish, with some predators forced to eat non-optimal prey items, or preferred feeding spots becoming unavailable. Some species may benefit from climate change shifts in the environment. Rising ocean acidity also affects the basic functions of fish, squid, invertebrates, and other marine species, including detrimental effects on metabolism, respiration and photosynthesis, which can thwart their growth and lead to higher mortality (Fabry, et al., 2008). The decrease of the extent of the Arctic ice pack impacts the lower trophic communities, which has impacts on fish communities. Warming ocean temperatures associated with climate change may increase all types of plankton growth rates and generation times in the region of the Proposed Action, and change the composition of lower trophic populations as warmer seas, open water, and increased radiative energy from the sun increases. Below is a summary of studies contributing to the knowledge of current fish and fish environments potentially affected by the Proposed Action.

Spring melt and river runoff greatly influence the characteristics of the inshore and nearshore Beaufort Sea (Section 3.1.2.1). This freshwater influx sets up a band (2-10 km) of brackish and sediment laden waters along the coast that narrows in summer due to decreased runoff and mixing by wind. Seasonal and interannual information about this Beaufort Sea inshore habitat and the fish that depend on the band was summarized by Craig (1984). He concluded that Arctic cisco, least cisco and Arctic char were dominant species in the coastal Beaufort. During summer months, as salinity in the band increased due to decrease in fresh water input, some marine species (or age groups of a species) move shorewards and feed nearshore on the abundant epibenthic fauna, which are organisms that live on the surface of the seafloor, but do not live within the substrate (Craig, 1984). Marine fish known to move inshore during summer months include: capelin, fourhorn sculpin, saffron cod, Arctic flounder, Arctic cod, and snailfish species (Jarvela and Thorsteinson, 1999; Craig, 1984; Craig, et al., 1985).

Jarvela and Thorsteinson (1999) studied the summer occurrence of epipelagic fish, which are fish associated with the part of the water column where light penetrates, along the eastern Beaufort Sea coast up to 30 kilometers offshore. The study area stretched from the Colville River east to the U.S.-Canada boundary, including Prudhoe Bay. The most abundant epipelagic fish caught were Arctic cod, capelin and snailfishes. Surface water temperatures and salinities varied seasonally and interannually and this influenced the spatial and temporal distribution patterns of the fish species.

In the summer of 2008, an offshore field survey of fish and benthic invertebrates of the Beaufort Sea was conducted by NOAA, University of Washington and University of Alaska (Logerwell, et al., 2010; Rand and Logerwell, 2011; Logerwell, et al., 2011). Across all bottom trawls, 6% of all weight was comprised of vertebrate fish species and 94% by weight were invertebrate species. During the course of this study 36 fish species were collected and identified. Arctic cod (*Boreogadus saida*) were the most abundant fish collected, both by weight and numbers. Fifteen species of smaller fish (eelpouts and sculpins) contributed a great number of fish to the total catch of the 2008 survey; however, they did not contribute much in terms of total biomass. Walleye pollock (*Theragra chalcogramma*) were present in small numbers and primarily as subadults. No specimens of adult or juvenile Pacific salmon species (*Oncorhynchus* sp.) were captured during sampling in the 2008 survey.

Rivers and streams discharging into the U.S. Beaufort Sea provide estuarine and freshwater habitat for several anadromous and migratory species including chum and pink salmon, Dolly Varden, whitefish, Arctic grayling, cisco species, and rainbow smelt (Johnson and Daigneault, 2013). Pacific salmon adults and juveniles occur in the Beaufort marine and estuarine environments; however, their numbers are low compared to the Bering Sea. Primarily pink and chum salmon (*Oncorhynchus gorbuscha* and *O. keta*), have been captured in the Beaufort nearshore (Craig, 1984; Craig and Haldorson, 1986; Fechhelm et al., 2009). As climate change occurs (ice reduction, warming waters) salmon are moving further north in greater numbers (Moss et al., 2009; Kondzela et al., 2009). According to the Anadromous Waters Catalog to date, pink and chum salmon have been documented by the USGS and USFWS as present in the Colville River basin (Johnson and Daigneault, 2013).

3.2.3. Birds

The Proposed Action Area in the context of this chapter is the area where bird populations may experience impacts from activities associated with the Proposed Action; this is primarily in the central Beaufort Sea marine and coastal areas. Many bird species use the marine waters and coastal and terrestrial habitats of the Proposed Action Area during spring, summer, and fall months. The Beaufort Sea's shallow shelf waters and coastal lagoon system provide important foraging and staging habitat for seabirds and loons, shorebirds, and waterfowl including sea ducks. Most of these water birds migrate through in the spring and again in late summer/fall months, some staging as they move through from Canadian or Russian breeding grounds or elsewhere. Many waterbirds, landbirds, and raptor species also breed across terrestrial portions of the Proposed Action Area during the short Arctic summer.

Spring migration in the Proposed Action Area occurs between late March and late May, with spring arrival times varying by species and their corresponding availability of habitat. Arrival times for many waterbirds, including eiders, typically coincide with the appearance of open water during migration to coastal breeding areas. Average spring arrival dates for many Arctic-nesting bird species have advanced by several days over recent decades (Ward et al., 2015). The fall migration period is more prolonged than spring migration, and begins in June or July with some failed breeders and nonbreeders. A few waterbird species move from tundra and freshwater habitats in the Proposed Action Area to molt in lagoons along the Beaufort and Chukchi Sea coasts. Fall migration timing from the Beaufort Sea area varies among species, and often by gender and age, with most birds having departed the Beaufort Sea before the formation of sea ice in late October.

A handful of landbird and raptor species may be found in the Proposed Action Area year-round, particularly in the terrestrial landscape. Common raven (*Corvus corax*) is the most abundant species occurring in nearby oilfields in the winter months. It is the only species recorded in the Audubon Christmas Bird Counts that have taken place annually in the Prudhoe Bay area between 1987 and 2012 (Streever and Bishop, 2014).

Although many Arctic species range across both seas, the Beaufort Sea exhibits important characteristics of avian fauna and habitats distinct from that of the adjacent Chukchi Sea. Species diversity and total seabird densities are lower in the Beaufort Sea than the Chukchi Sea, which is more plankton-rich and closer to the Bering Sea's nutrient in-flow and seabird cliff habitat. The Beaufort Sea coastal shelf is shallow and narrow and the deep Arctic Basin is a dominant physical feature. Beaufort Sea avian marine fauna is characterized by certain pelagic fish-eating birds, and high relative densities of benthic-feeding sea ducks (Sigler et al., 2011). Some birds are top predators on Beaufort Sea fish resources, while others prey on a range of trophic levels. Sensitivity to lower trophic or abiotic linkages in the current dynamic state of these ecosystems may be resulting in significant variability in abundances, relative abundances, and distributions (e.g., new dominance of planktivorous seabirds in northeastern Chukchi Sea over previous decades) (Gall, Day, and Morgan, 2013; Piatt, Sydeman, and Wiese, 2007).

The following sections summarize relevant movement patterns, locations, and life history characteristics for key avian species groups. These groups include species that have special legal status, high populations in the Proposed Action Area, particular sensitivity to certain activities, and/or other relevant life history characteristics in common.

3.2.3.1. ESA Listed Birds

Two diving sea ducks, the spectacled eider (*Somateria fischeri*) and the Alaska-breeding population of Steller's eider (*Polysticta stelleri*) are listed as threatened under the Endangered Species Act (ESA). Both species breed on the Alaska North Slope (ANS) and forage on the shallow (10-40 meters (32-131 ft)) Alaskan Beaufort Sea ocean shelf, important habitats for eiders in general (Kuletz et al., 2015). Spectacled eiders are expected to occur regularly in the Proposed Action Area (Hilcorp, 2015, Appendix A, page 4-117), while Steller's eiders are rare east of the Point Barrow area but may occur occasionally.

Spectacled Eider

The spectacled eider was listed as a threatened species throughout its range under the ESA in 1993 (58 *FR* 27474, May 10, 1993). Spectacled eiders on the ANS breed across the Arctic Coastal Plain (ACP) east to approximately between the Shaviovik and Canning River deltas (TERA, 2002; Larned, Stehn, and Platte, 2012). The ANS population is the larger of the species' two North American breeding populations, the other being on the Yukon-Kuskokwim Delta (YKD), and has been stable since surveys began in the early 1990s (Bowman, et al, 2015; Larned, Stehn, and Platte, 2009). The most currently available population estimate for the ACP portion of the ANS is about 14,800 paired birds (Stehn, Larned, and Platte, 2013). It has been estimated that almost 34,000 total spectacled eiders, including fledged (flight capable) juveniles, are present on the entire ANS in October (Stehn et al., 2006).

Spectacled eiders tend to migrate along direct offshore routes or to follow coastlines. They migrate north using the spring lead system from the species' single wintering area in the Bering Sea. The spring lead systems of the Chukchi Sea, including Ledyard Bay, and of the Alaskan Beaufort Sea as far east as the Sagavanirktok River delta (in the Proposed Action Area) are the first available open-water areas along the spectacled eider path to its ACP breeding grounds. The Alaskan Beaufort Sea within approximately 30 kilometers (19 mi) of the coast is recognized as important habitat for spectacled eiders during most of the open water period, which includes their pre-breeding, breeding, and post-breeding migration periods (Sexson, Pearce, and Petersen, 2014). In marine waters, spectacled eiders are benthic feeders on invertebrates, primarily clams, and possibly also amphipods and crabs (Petersen, Piatt, and Trust, 1998; USFWS, 1996).

Spectacled eiders can be expected in the Proposed Action Area from late May through September or October, nesting, raising or developing as broods, foraging, or moving through on migration. The birds will arrive in open water offshore in late May through early June, and within a week, adults move on to land to nest. Adult female spectacled eiders of the Beaufort Sea area demonstrate high levels of interannual breeding site fidelity, as they do elsewhere in Alaska. Actual nest initiation (i.e., first egg laid) is expected in the second and third weeks of June, with exact timing probably in response to snowmelt and tundra flooding conditions (Sexson, Pearce, and Petersen, 2014; TERA, 2002). Spectacled eiders are known to nest between the coast and approximately 25 kilometers (15.5 mi) inland from the coast of Foggy Island Bay (TERA, 2002; Larned, Stehn, and Platte, 2006). The center of the species' overall ACP distribution is farther west, along the Chukchi Sea coast and northeast of Teshekpuk Lake. Nesting densities are variable, however, and some of its highest ACP densities do occur in the Prudhoe/Kuparuk area (Larned, Stehn, and Platte, 2011).

In the Kuparak oilfield, spectacled eiders nest primarily in non-patterned wet meadows within wetland complexes containing emergent grasses and sedges (Anderson and Cooper, 1994; Anderson

et al., 2009), and similar breeding habitat affinities may be expected in the nearby Proposed Project Area. After hatching in mid-July (Petersen, Grand, and Dau, 2000), spectacled eider hens and broods move to deep ponds with pendant grass (*Arctophila fulva*) vegetation or shallow water sedge (*Carex aquatilis*) wetlands (Safine, 2011, 2013). While on the breeding grounds, adults and ducklings primarily feed on invertebrates and plant seeds in tundra ponds (Petersen, Piatt, and Trust, 1998; USFWS, 1996).

Post-breeding, male spectacled eiders leave the nesting area first, within 7-33 days of coming ashore at the onset of incubation. Males move to Beaufort or Chukchi Sea open waters until they depart for Chukchi Sea or Russian molting areas (Sexson, Pearce, and Petersen, 2014). Locally breeding males are not expected to remain in the Beaufort Sea past July. Female spectacled eiders move from land to Beaufort Sea marine waters after their nesting ends between July and September, a few lingering in the Beaufort Sea until October. Females whose nests fail are the first to go to the coast. Juveniles may be found onshore until September, and in Beaufort Sea waters with females until late September or October, although adults generally depart the Alaskan Beaufort Sea 1-2 weeks prior to offspring (Sexson, Pearce, and Petersen, 2014).

Male spectacled eiders molt primarily in Russia and Ledyard Bay, beginning to gather in Ledyard Bay in July, almost two months before females. Females and many juveniles from the Proposed Action Area likely migrate with those from the Colville River Delta to the eastern Chukchi Sea, primarily Ledyard Bay, and remain there for the flightless molt period (Sexson, Pearce, and Petersen, 2014). Juvenile post-fledging dispersal is more variable than adult dispersal, some ranging as far as the Alaska Peninsula on their first molt migration. The species' molt migration and fall migration have primarily been observed to occur over offshore waters rather than land, with females flying almost 10 kilometers farther from the Beaufort Sea shore than males (Petersen, Larned, and Douglas, 1999).

By the end of October, most spectacled eiders have departed their respective molting grounds for the Bering Sea. Most of the species breeds on the Russian Arctic Coastal Plain, and both the Russian and Alaskan birds winter together from late November through mid-February in the species' only known wintering area: openings in pack ice south and southwest of St Lawrence Island (Petersen, Larned, and Douglas, 1999; Sexson, Pearce, and Petersen, 2014). This wintering area and the Ledyard Bay area are both designated under the ESA as critical habitat for the spectacled eider (66 *FR* 9145, February 6, 2001). There is no designated spectacled eider critical habitat associated with the Beaufort Sea.

Steller's Eider

The Alaska-breeding population of Steller's eider is listed as threatened under the ESA (62 *FR* 31748, June 11, 1997). The least-abundant eider in Alaska, it had a discontinuous historic breeding range along the coast from the Alaska Peninsula northward to the Beaufort Sea (Quakenbush et al., 2002). Less than 5% of the breeding population of Steller's eiders nests in Arctic Alaska (Rothe and Arthur, 1994). A very small remnant population sometimes nests on the Yukon Kuskokwim Delta, but has "essentially disappeared" according to the Sea Duck Joint Venture (2016), and a small number of Steller's eiders breed on the ACP between Point Lay and the Prudhoe Bay vicinity, primarily near Utqiagvik (Obritschkewitsch and Ritchie, 2015). The Alaska-breeding and majority of the Russia-breeding populations molt and winter together in waters off of southwestern Alaska. Periodic non-breeding of the Alaska population, coupled with low nesting and fledging success in general, has resulted in very low productivity (Quakenbush et al., 2004) and may make the population particularly vulnerable to local extinction (extirpation).

Estimating the population of this rare species is difficult, but the most recent estimate for the ACP population is 680 birds (Stehn, Larned and Platte 2013). The authors found an average negative growth rate of 0.95; however, a definitive population trend estimate is not possible due to relatively

few observations in many years and the birds' variable nesting and occupancy propensity (Sea Duck Joint Venture, 2016). Intervals of up to five years have occurred with little or no evidence of Steller's eider nesting near Utqiagvik (Safine, 2013). Martin et al. (2015) surmise that most birds in those years depart the area without occupying territories or initiating nesting.

Small Steller's eider flocks appear in the spring leads off Barrow Canyon in May, likely already having begun pair formation, and move on to the tundra breeding grounds in early June. In the Utqiagvik area, where nest timing is expected to be similar to the Proposed Action Area, nests usually must be initiated by the last week of June to allow the young to fledge prior to freeze-up (Quakenbush et al., 2004). Steller's eider prefers to nest near ponds with pendant grass (Safine, 2013). Breeding male Steller's eiders depart the ACP after the nest is initiated in mid- to late June. Hatching occurs from mid-July through early August (Rojek, 2006, 2007, 2008). Nest survival rates are significantly affected by nest predation from fox. Other nest predators likely include birds such as jaegers, glaucous gull, snowy owl, and common raven (Safine, 2013). Within about one day after hatch, hens move their broods to ponds with emergent vegetation, particularly water sedge or a mix of water sedge and pendant grass, that provides cover for vulnerable young (Rojek, 2006; Rojek, 2007; Safine, 2011; Safine, 2013). They feed on insect larvae and other wetland invertebrates. Broods may move kilometers away from the nest prior to fledging (Safine, 2013). Fledging occurs from 32–37 days after hatching. Broods may remain in the vicinity of the brood rearing area for up to 17 days post-fledging before moving to marine waters or leaving the area (Safine, 2013; Obritschkewitsch et al., 2001; Rojek, 2006).

Successful female eiders and their young-of-the-year appear to depart the ACP in September. Females and broods occasionally move to Point Barrow nearshore waters, but after early to mid-September females begin their migration to the southwestern Alaska molting areas (Martin, et al., 2015; Safine 2013, 2011). Because of their low overall ACP abundance and the distance of the Proposed Action Area from the known Utqiagvik center of Steller's eider ACP nesting range, Steller's eider is expected to occur only rarely in the Proposed Action Area.

3.2.3.2. Other Birds

Waterfowl

Sea ducks, especially common eider (*Somateria mollissima*), king eider (*S. spectabilis*), and long-tailed duck (*Clangula hyemalis*) are common Beaufort Sea coastal breeders. Greater white-fronted goose (*Anser albifrons frontalis*), lesser snow goose (*Chen caerulescens caerulescens*), Canada goose (*Branta canadensis*, *B. hutchinsii*), black brant (*B. bernicla nigricans*), and tundra swan (*Cygnus columbianus*) are other locally breeding waterfowl species common in nearshore coastal waters of the Beaufort and Chukchi Seas, as are scoters (*Melanitta* spp), mergansers, and dabbling ducks. Waterfowl most likely to occur in the Proposed Action Area are described further below.

Common Eider

Pacific common eider (*S. mollissima v-nigra*) breeds in Alaska and western Canada. This sea duck migrates during spring along the coastline of the Beaufort and Chukchi Seas, staging in leads as they open up between the pack ice and landfast ice. Common eiders nest typically in loose colonies on the barrier islands or spits along the Chukchi Sea and Beaufort Sea coasts, with highest densities in Alaska often occurring along the central Beaufort Sea coast between Harrison Bay and the Canning River, in or near the Proposed Action Area (Dau and Bollinger, 2012 and 2009; Lysne, Mallek, and Dau, 2004). Females return to breeding sites year after year. Dau and Bollinger (2012) report that the USFWS 2011 common eider ACP barrier island breeding survey, found 83 adults on the mainland shore around Foggy Island Bay and over 60 around the Foggy Island Bay barrier islands during early July (the incubation phase prior to male dispersal).

Common eider is considered highly vulnerable to climate change because of its preference for nesting on low-lying barrier islands and similar coastal areas which are subject to overwash and erosion from the increasing frequency and severity of storms (Liebezeit et al., 2012; Sea Duck Joint Venture, 2015b). A storm surge on July 18, 2016, flooded most of the monitored common eider nests along the coast of the Arctic National Wildlife Refuge. It was the largest recorded surge before July 30th in any year since recording began in 1995 (Wiese, Latty, and Hollmen, 2016).

Successful hens seldom leave the nest to feed during incubation. However, common eiders, including failed breeders and males, may be found using local nearshore waters, particularly coastal lagoon habitat, throughout the breeding season. Fischer and Larned (2004) surmised that because eider densities did not vary during summer months, the eiders they observed in the water near barrier islands were local breeders rather than molt or fall migrants. This is consistent with Petersen and Flint (2002), who showed that satellite-tagged common eider hens remained in shallow waters close to their Beaufort Sea coast breeding sites through September, likely molting during that time. The McClure/Stockton Islands area around Foggy Island Bay has held some of the highest concentrations of common eiders during late July/early August ACP waterfowl surveys, with between 600 – 800 birds observed in the 2002 and 2003 seasons (Lysne, Mallek, and Dau, 2004).

After the molt, some common eiders move offshore into pelagic waters, but most remain close to shore (Petersen and Flint, 2002; Divoky, 1987). For U.S. and Canadian Arctic-breeding subpopulations, primary molt and staging locations and movements among them, are not well understood (Sea Duck Joint Venture, 2015). Post-breeding males and nonbreeders along the Beaufort Sea coast, however, begin to migrate westward through nearshore waters toward the Chukchi Sea in late June; most breeding female common eiders and their young follow in late August and September (Dickson, 2012a) and are gone by late October or early November. Most males are out of the Beaufort Sea by late August or early September. Morgan, Day, and Gall (2013) observed very few common eider, all within 20 kilometers (12.4 mi) of shore, in late September in Camden Bay, to the east of the Proposed Action Area.

King Eider

King eider is one of the most abundant birds in the Beaufort Sea, with approximately 400,000 breeding around the Alaskan and U.S. Beaufort Sea coast, many or most migrating in the spring and fall in often enormous flock events close to Point Barrow (Quakenbush, et al, 2009). Average indicated total king eiders on the Alaska ACP between 2005-2014 is about 20,000 (Sea Duck Joint Venture, 2015). Similar to the other eiders, king eiders migrate during spring along the Beaufort and Chukchi Sea coasts, staging in open water leads. Arrival times in the Beaufort Sea are dependent upon the location and timing of offshore leads along the Chukchi Sea. King eiders generally begin to arrive in the Beaufort Sea by the middle of May, with peak spring staging numbers occurring until about June 5th (Wilson et al., 2012, Dickson, 2012b, Peterson 2009, Oppel and Powell 2010). Mean first arrival on the local breeding grounds is the end of May, the most recent recorded mean in a Colville River delta study on trends in first arrival dates (Ward et al., 2016). Like the 15 other migratory bird species in that study, however, king eider's arrival date has significantly advanced (i.e., occurred earlier) over the past 50 years. Because local climactic conditions, i.e., temperature, were found to be the most important indicator of this effect, this trend in advancing arrival dates can be expected to continue (Section 3.1.6).

King eiders nest regularly in ACP coastal areas. Mean king eider breeding density on the ACP is generally highest in an area southeast of Teshekpuk Lake, but has also been high inland from Foggy Island Bay and in the vicinity of the Sagavanirktok River Delta (Larned, Stehn, and Platte, 2011, 2009). Dau and Bollinger (2009), surveying in early July, a few weeks later in the breeding season, observed that king eider densities were higher on the Beaufort Sea coastlines than the Chukchi Sea coastlines, with an observed 400 king eiders along the Beaufort Sea shoreline and 176 along barrier

islands, although these numbers were much lower in 2011 when highest densities shifted to Peard Bay (Dau and Bollinger, 2012). Similar to common eiders, king eider females exhibit strong natal site fidelity to breeding areas. Males usually do not return to the same breeding area.

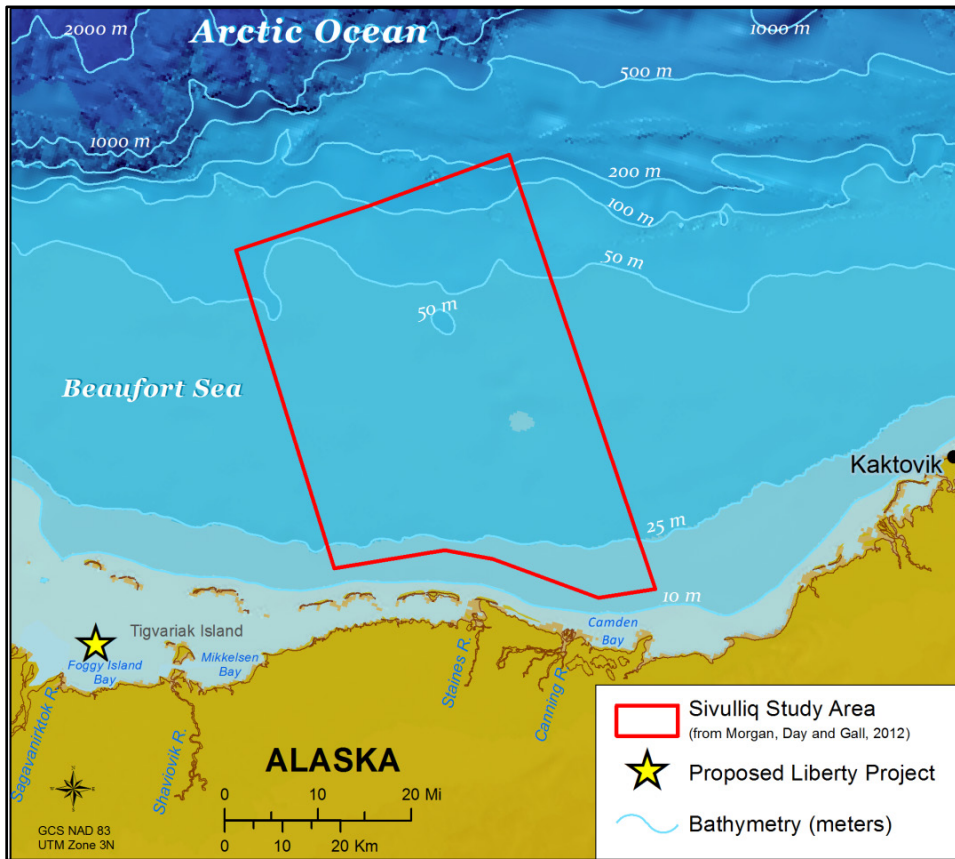

Figure 3.2.3-1. Sivulliq study Area.

Post-nesting, the westward molt-migration of several hundred thousand male king eiders past Point Barrow during July and early August is one of the most obvious and well-known avian phenomena of the Beaufort Sea (Johnson and Richardson, 1982). Satellite telemetry shows that, once departed from coastal waters adjacent to breeding areas, king eider individuals may spend more than two weeks staging offshore in the Beaufort Sea prior to fall migration (Dickson, 2012b; Phillips, 2005; Powell et al., 2005). While some king eiders molt in the Beaufort Sea, a majority molt in the Chukchi or Bering Seas (Dickson, 2012b; Oppel, Dickson, and Powell, 2009; Phillips et al., 2007). During migration to molting areas, king eiders occupy a wide area ranging from shoreline to >50 kilometers (>31 mi) offshore (Phillips, 2005). Female king eiders remain in the Beaufort Sea longer than males, possibly to replenish fat stores depleted during egg laying and incubation (Powell et al., 2005). Some females cross the Beaufort Sea in October, post-molt (Dickson, 2012b). Morgan, Day, and Gall (2012) observed over 500 king eiders, distributed between about 12 and 70 kilometers (7.5-44 mi) from shore in the Sivulliq study area, a large area of open water that begins roughly 50 kilometers (31 mi) east of the proposed LDPI, extends eastward into Camden Bay and seaward to roughly the edge of the shelf in the eastern Beaufort Sea (Figure 3.2.3-1). The authors found greater numbers of king eiders than any other eider species in the late September bird survey (Figure 3.2.3-1).

Long Tailed Duck

Long-tailed duck is the most abundant benthic-foraging sea duck in the Beaufort Sea, particularly in the late summer and fall. Long-tailed ducks feed primarily on benthic invertebrates and are believed

to be well adapted to shifts in prey availability, opportunistically feeding according to species availability (Johnson, 1984). They move locally among marine habitat types (e.g., nearshore vs offshore) to locate better foraging (Flint et al., 2016). In the late spring they migrate north and east along the Beaufort and Chukchi Sea coastlines to breeding areas on the ACP in Alaska and Canada. Mean first arrival date in the vicinity of the Proposed Project (i.e., on the Colville River Delta) is currently May 27th (Ward et al., 2016), but as with king eider (above) and the other birds studied, this date has been advancing.

Stehn, Larned, and Platte (2013) re-evaluated waterbird breeding (June) survey data across the ACP, including inland habitat, from 1986-2012. The average, uncorrected population index was over 50,000 observed long-tailed ducks, surpassed in June only by white-fronted goose, northern pintail (*Anas acuta*, a dabbling duck), and unidentified shorebird species. Aerial surveys a few weeks later in the breeding season in early July typically record more long-tailed ducks than any other sea duck species along ACP coastal habitats, with roughly two-thirds of these associated with mainland habitats, and the rest with barrier islands. In shoreline habitat-only surveys, only glaucous gull (*Larus hyperboreus*) and sometimes surf scoter (*Melanitta perspicillata*) may exceed the numbers of long-tailed ducks among breeding waterbirds (Dau and Bollinger, 2011 and 2009).

Long-tailed duck is typically also one of the most abundant species to undergo a post-breeding flightless wing-molt in the Beaufort Sea coastal lagoons. Individual birds are flightless for 3-4 weeks. Like eiders and loons, post-breeding long-tailed ducks generally stage in coastal areas here, move into offshore waters, and then migrate westward out of the Beaufort Sea. They use lagoon and other coastal habitats heavily all along the ACP during July and August, numbering in the tens of thousands (Flint et al., 2016; Johnson and Richardson, 1982). The Tigvariak Island vicinity east of the Proposed Project Area hosts some of the highest densities of long-tailed ducks observed on the Beaufort Sea coast during the molting period: hundreds were observed in the McClure/Stockton Islands in the early 2000s, with thousands in the narrower lagoon system that begins just to the east of Foggy Island Bay (Fischer and Larned, 2004; Lysne, Mallek, and Dau, 2004). In late September, an estimated 29,000 long-tailed ducks were distributed across the Sivulliq study area (Figure 3.2.3-1) just east of the Proposed Action Area alone—second in observed marine bird abundance only to short-tailed shearwaters (Morgan, Day, and Gall, 2012). Surveys suggest that the ACP population of long-tailed ducks underwent a long-term decline in the last decades of the 20th Century, stabilizing or slightly increasing more recently (Stehn, Larned, and Platte, 2013; Bowman, et. al., 2015).

Greater White Fronted Goose

Greater white-fronted goose (white front) is a large herbivorous waterfowl and one of the earlier arriving birds on the ACP in the spring. Mean first arrival date for white-front on the Colville River Delta is currently May 12th (Ward et al., 2016). Spring arrival dates for several Arctic-nesting bird species have been advancing earlier over recent decades. White-front and lesser snow geese, two important subsistence species on the North Slope, demonstrate the greatest mean rates of advancement (Ward et al., 2016). White front breed in abundance on the ACP, with adult white-front numbers estimated around 200,000 in June (Stehn, Larned, and Platte, 2013; Larned, Stehn, and Platte, 2012, 2011). This species tends to nest only loosely in colonies, compared to snow geese and brant. Site specifically, 33 white front were observed along the mainland coastline around Foggy Island Bay in a July survey in 2009 but none on its barrier islands. The following year, while none were observed in that same survey segment, numbers had risen at the Sagavanirktok River Delta immediately to the west (Dau and Bollinger, 2011, 2009).

Lesser Snow Goose

Lesser snow goose mean first arrival date on the Colville River Delta is currently May 27th (Ward et al., 2016). This species, an herbivorous colonial nester, has the fastest population growth rate among all ACP waterbird species (Stehn, Larned, and Platte, 2013; Ritchie et. al., 2013). Like brant, it eats

salt-tolerant vegetation which appears to be increasing along the coast over recent time as salt water intrudes. Unlike brant, however, snow geese find forage early in the nesting season by grubbing plants from the soil, roots and all. Over 90% of the adults observed on the ACP have been along the Beaufort Sea coastline, versus the Chukchi Sea (Dau and Bollinger, 2011, 2009). The original nesting colony and brood-rearing site of snow geese in Alaska was thought to be on Howe Island in the Sagavanirktok River delta, and hundreds of nesting geese continue to be observed on the island from the Endicott Road. In 2014, nest estimates at the Howe Island colony had risen to over 1,500 (Bishop and Streever, 2016). Since the 1990s nesting and brood-rearing sites have continued to spread along the Central Beaufort Sea Coast as well (Noel, Johnson, and Butcher, 2004). Up to 528 adults have been observed during the July breeding season in the Foggy Island Bay area (Dau and Bollinger, 2009).

Black Brant

Black brant, or simply “brant,” arrives on the ACP around the same time as lesser snow geese, with mean first arrival on the Colville River Delta currently on May 25th but advancing (Ward et al., 2016). This goose also forages on salt marsh plants, but cannot take advantage of early grubbing as snow geese can. Brant typically nest colonially on spits or on islands formed in large river deltas, or to a lesser degree on barrier islands. They are typically most abundant along the Central Beaufort Sea coast between the Colville and Canning Rivers, in the general vicinity of the Proposed Action Area (Dau and Bollinger, 2011, 2009; Stickney and Ritchie, 1996). Brant have a mildly positive growth trend on the ACP where there are 5,000 or more nesting pairs (Ritchie, et al., 2013; Stehn, Larned and Platte, 2013, 2012), with more population variability in the oil fields east of the Colville River delta (Bishop and Streever, 2016). During the Foggy Island Bay area breeding season they have been associated with barrier island habitat (Dau and Bollinger, 2009). Post-breeding, thousands of brant molt in lake and lagoon habitat on the Central Beaufort Sea coast, primarily west of the Proposed Action Area and north of Teshekpuk Lake in Smith Bay (Flint, Meixell, and Mallek, 2014). Brant have shifted their foraging areas away from inland lakes and toward coastal saltmarsh in recent years. This corresponds with increased goose grazing salt marsh habitat on the Beaufort Sea coast caused by inundation, subsidence, and sedimentation that may in turn be accelerating with sea ice decline, ocean storm surge, freshwater flooding, and increased coastal erosion (Tape, et. al., 2013). As snow goose increase on the ACP, however, it has been suggested that they could eventually out-compete brant and damage the salt marsh habitat, resulting in a negative long-term impact on brant (Ritchie et. al., 2013).

Tundra Swan

Tundra swan, with a broad breeding range that encompasses much of Alaska, is the largest ACP breeding waterbird. Mean Colville River Delta first arrival date is currently May 21st but advancing (Ward et al., 2016). Tundra swans’ ACP breeding population is growing (Streever and Bishop, 2014; Stehn, Larned, and Platte, 2013). In June, tundra swans are found breeding in some of their highest ACP densities on the Colville River and Sagavanirktok River Deltas (Larned, Stehn, and Platte, 2011). Swans share the Surfcoote colony on the Sagavanirktok River Delta with small numbers of other birds including brant, king eider, long-tailed duck, Pacific loon, and glaucous and Sabine gulls (Bishop and Streever, 2016). They are observed in low numbers but wide distribution during July along the Beaufort Sea coastline (Dau and Bollinger, 2011; Stehn and Platte, 2000).

Scoters

Three species of scoters (a sea duck) regularly breed on the ACP and use Beaufort Sea coast barrier island habitat between June and September. Surf scoters (*M. perspicillata*) are especially prevalent in high-density rafts of several hundred birds, particularly in Harrison Bay and Simpson Lagoon (Fischer, Tiplady, and Larned, 2002). Fischer and Larned (2004) report that Beaufort Sea coast scoters are more common in June than in August, and more common in shallow waters (<10 m). Surf

scoters are found in low numbers in early July around the barrier islands near the Proposed Action Area (e.g., 22 in 2009 and 12 in 2011 near Tigvariak Island; Dau and Bollinger, 2009 and 2012, resp.). A few white-winged (*M. fusca*) and black scoters (*M. nigra*) have also been counted near the mainland shore between the mouth of the Sagavanirktok River and the inside of the Stockton Islands (Dau and Bollinger, 2009 and 2012).

Mergansers

Red-breasted (*Mergus serrator*) and common (*M. merganser*) mergansers are fish-eating sea ducks regularly occurring in low numbers in nearshore waters along the Beaufort Sea coast (Fischer and Larned, 2004), including tens of red-breasted mergansers regularly observed west of Tigvariak Island (Dau and Larned, 2009 and 2012).

Dabbling Ducks

Several species of “dabbling ducks” (i.e., those that feed by skimming in shallow, usually fresh or brackish, water) breed on the ACP. These include American green-winged teal (*Anas crecca*), American wigeon (*A. americana*), northern pintail (*A. acuta*), and mallard (*A. platyrhynchos*) and possibly others (Larned, Stehn, and Platte, 2012; Stehn, Larned, and Platte, 2013; Streever and Cargill Bishop, 2013). Dabbling ducks, particularly northern pintail, are expected to occur in shallow nearshore marine waters and possibly terrestrial portion of the Proposed Action Area (Dau and Bollinger, 2009 and 2012). Northern pintail’s current mean first arrival date is in late May, but this date has been advancing in recent decades (Ward et. al., 2016).

Seabirds and Loons

Arctic tern (*Sterna paradisaea*), black guillemot (*Cepphus grylle*), Ross’s gull (*Rhodostethia rosea*), ivory gull (*Pagophila eburnea*), glaucous gull (*Larus hyperboreus*), and Sabine’s gull (*Xema sabini*) breed circumpolarly in the Arctic. Of these species, only Arctic tern and glaucous gull may be considered likely to nest in the terrestrial portion of the Proposed Action Area, but all of these species regularly range into the Beaufort Sea. Seabirds that breed in the Bering Sea area or elsewhere, but regularly range into the Beaufort Sea include black-legged kittiwake (*Rissa tridactyla*) and short-tailed shearwater (*Ardenna tenuirostris*). Another type of seabird, the jaeger, is represented by three species, pomarine (*Stercorarius pomarinus*), parasitic (*S. parasiticus*) and long-tailed (*S. longicaudus*), breeding on the ACP tundra and foraging in open water of the Beaufort and Chukchi Seas. These seabird species are described further below, along with the three species of loons that breed in the vicinity, Pacific loon (*Gavia pacifica*), red-throated (*G. stellata*), and yellow-billed (*G. adamsii*).

Arctic Tern

Arctic tern is a common surface-feeding seabird in the Beaufort Sea in summer (July and August) (Kuletz, et. al., 2015; Wong et. al., 2014; Divoky, 1987), where it forages on Arctic cod, other forage fish, and zooplankton. The Arctic tern has a wide, circumpolar, breeding distribution and nests colonially on open land near marine or fresh water. Nesting densities across the entire ACP have been observed at between 0.3 and 0.4/km² (Larned, Stehn, and Platte, 2012). In aerial surveys along the coast of the ACP, approximately 2,500 breeding birds have been observed, primarily on mainland areas along the Chukchi Sea (Dau and Bollinger, 2009, 2012). In the Proposed Action Area, especially the coastal Beaufort Sea in the vicinity of the Sagavanirktok River Delta, Arctic terns are considered a fairly common migrant and breeder, and regularly nest on barrier islands. In 2011, just over 30 nests were located on the islands around Foggy Island Bay—the highest numbers of Arctic tern barrier island nests anywhere on the ACP that year (USFWS, 2014; Dau and Bollinger, 2012).

Black Guillemot

Black guillemot is a diving seabird that is closely associated with sea ice throughout its lifetime, where it forages extensively on Arctic cod (Gall, Day, and Morgan, 2013; Sigler et al., 2011). Black

guillemot is an uncommon local breeder from Seahorse Island and Point Barrow east to Igalik Island, and a rare breeder farther east to Barter Island (USFWS, 2015; Denlinger, 2006). Nests off of the ACP, sometimes occurring singly or in small, loose aggregations, have been located under driftwood or other debris on barrier islands. Despite the small breeding population in Alaska (the Beaufort and Chukchi Sea colonies have a combined total of fewer than 1,000 nesting birds (USFWS, 2015)), about 70,000 post-breeding guillemots from the U.S. and Russia use pelagic areas of the Beaufort and Chukchi Seas (Divoky, 1987). Recent analysis shows higher relative Beaufort Sea black guillemot abundance than in either the Chukchi or Bering Seas, helping to distinguish the Beaufort Sea as a distinct biogeographic zone characterized by piscivorous seabirds and benthic-foraging waterbirds (Sigler et al., 2011). Hotspots (areas of relatively high densities) of foraging black guillemots have been recently identified in the Beaufort Sea, including in offshore waters in fall over the slope north of the mouth of Barrow Canyon and on the shelf near Camden Bay (Kuletz et al., 2015). Black guillemot was the only alcid species identified on transect in the September, 2010, Sivulliq study area marine bird survey (Figure 3.2.3-1) (Morgan, Day, and Gall, 2012). Black guillemot use open leads if they also appear in the western Beaufort Sea in the winter months (Divoky, 1984).

Ross's Gull and Ivory Gull

Ross's gull and ivory gull are ice-associated gulls that have remote circumpolar breeding distributions, primarily in Siberia, Greenland, and the Canadian High Arctic, and remain among the least studied seabirds. Ross's gull has been most well-known in the U.S. Arctic for their conspicuous late fall (September and October) migration off of the coast of Point Barrow. Ross's gull is expected to be most common in the fall (Gall, Day, and Morgan, 2013), and was the most common of the 4 species of larids (gulls and kittiwakes) encountered on the Sivulliq study area (Figure 3.2.3-1), where they were seen in groups of 1 – 14 birds (Morgan, Day, and Gall, 2012). Kuletz et al. (2015) identified several fall hotspots and high density areas for Ross's gull in pelagic Beaufort and Chukchi Sea waters, and nearshore in Camden Bay.

Ivory gulls are also closely associated with the ice edge throughout their lifecycle (Divoky, 1987; Haney et al., 2008), where they feed on fish and invertebrates, and scavenge on marine mammal carcasses left by polar bears. Flocks of a few hundred have been observed moving past Point Barrow in October and small numbers are believed to migrate through the Chukchi and possibly Beaufort Seas in September and October to wintering areas (Divoky et al., 1988; Haney et al., 2008). Strong decreases in the numbers of both Ross's gull and ivory gull have been recently detected in northern Greenland and northern Canadian waters, and may be due to changes in pack ice extent and distribution, shifts in population centers (e.g., potential corresponding increases in Russian waters), or something else (Joiris, 2016).

Glaucous Gull

Glaucous gull is a pelagic surface-feeder and one of the more abundant Beaufort Sea larids, often congregating at food sources (Kuletz, et. al, 2015; Divoky, 1987). More widely distributed in the Beaufort Sea in the fall than in summer (Kuletz et al., 2015), they may be encountered throughout the open water period. From late July to late September it is most common in distant offshore Arctic Basin waters where it moves to forage and stage post-breeding (Morgan, Day, and Gall, 2012). In the Sivulliq study area surveys (Figure 3.2.3-1), glaucous gulls were less common than Ross's gull and black-legged kittiwake, but as one of the first birds to arrive in spring this anomaly is believed to be because they had already begun to depart (Morgan, Day, and Gall, 2013). Surveys in the same vicinity in the 1970s (Divoky, 1984) found glaucous gulls had the highest larid densities. Glaucous gull is one of the most common and abundant seabird species breeding along the Beaufort Sea coast, where it breeds in roughly the same densities as along the Chukchi Sea coast. In 2011, over 600 adults were counted during the breeding season on roughly 60 kilometers (37 mi) of mainland and barrier island coastline around Foggy Island Bay (Dau and Bollinger, 2012). Mean first arrival date

on the local breeding grounds is currently May 11 (Ward et al., 2016), but as noted above for the various waterfowl species studied, this trend in advancing arrival dates can be expected to continue (Section 3.1.6).

Sabine's Gull

Sabine's gull is a pelagic surface-feeding seabird that occurs in relatively low abundances across the Beaufort Sea, except for some higher density foraging hotspots recently identified (Kuletz et al., 2015). Low numbers of Sabine's gull nest regularly along the ACP mainland, with 22—one of the survey's highest recorded densities—observed on barrier island nesting habitat in Foggy Island Bay during the 2011 breeding season (Dau and Bollinger, 2012). Mean first arrival date on the Colville River Delta breeding grounds is currently May 25th, but this date has been steadily advancing (Ward et al., 2016).

Black Legged Kittiwake

Black-legged kittiwake is an off-shore surface forager that is primarily a fish eater, but also consumes large zooplankton, including euphausiids (small shrimp-like crustaceans). Breeding colonies of black-legged kittiwakes in the Chukchi Sea (Cape Thompson and Cape Lisburne) are at the northern limit of their Alaska breeding range. Black-legged kittiwake is one of the most common and widespread surface-feeding avian species across the northern Bering, Chukchi, and Beaufort Seas (Kuletz et al., 2015; Wong, 2014). They do not nest in the terrestrial portion of the Proposed Action Area, but forage in the Beaufort Sea, and may be expected to occur in the marine and coastal waters of the Proposed Action Area. They are most abundant from mid-July until September in the Chukchi Sea, and likely the Beaufort Sea, but do also occur in the area in late September-early October (Gall and Day, 2012; Divoky, 1987).

Short Tailed Shearwater

Short-tailed shearwaters (shearwaters) breed in the Southern Hemisphere. Gall and Day (2012) suggested that these highly migratory birds can rapidly respond to changes in oceanic conditions and exploit food resources when and where they are available. At northern latitudes, shearwaters forage at highly productive patches of large zooplankton (euphausiids and amphipods), but also eat fish and squid, and can feed on the surface or dive (Kuletz et al., 2015). An estimated 100,000 shearwaters have passed Point Barrow in one mid-September day (Divoky, 1987). Kuletz (2011) reported a single flock numbering over 15,000 shearwaters in the western Beaufort Sea in late August–early September, 2011. Kuletz and Labunski (2017) reports shearwaters as the relatively most abundant seabird in offshore waters of the Alaskan Beaufort Sea and Morgan, Day, and Gall (2012), found short-tailed shearwaters to be the most abundant and perhaps most widely distributed seabird across the Sivulliq study area site (Figure 3.2.3-1).

Jaegers

Jaegers forage at sea when they are not breeding, primarily scavenging and stealing from other birds, or directly preying on, other seabirds. Three species of jaegers (pomarine, parasitic, and long-tailed) are commonly summer in the Beaufort Sea in summer until late September, then move south to the Bering Sea (Divoky, 1984; Divoky, 1987). Jaegers are dispersed throughout nearshore and pelagic areas of the Beaufort Sea, with high overall abundance but no known high concentration areas. Abundance and density are believed to be considerably lower in the central and eastern Beaufort Sea than in the Chukchi Sea (Divoky, 1987). All three species nest on the ACP, where pomarine and long-tailed jaegers are uniquely dependent on lemming prey on the tundra for successful breeding. Jaegers are territorial nesters that could breed in tundra in the Proposed Action Area. One or two pomarine and parasitic jaegers were observed during the Sivulliq study area surveys (Figure 3.2.3-1) just east of the Proposed Action Area (Morgan, Day, and Gall, 2012).

Loons

Pacific, red-throated, and yellow-billed loons occur in nearshore coastal waters of the Beaufort and Chukchi Seas, and breed across the ACP. They are all territorial nesters and diving foragers on primarily fish. Of 16 avian species examined, Ward et al. (2016) found loons to have the latest mean first arrival (i.e., early June) on Colville River Delta nesting grounds. They are unable to walk well on land, but are excellent swimmers that vigorously defend their aquatic breeding territory and floating nests. Large numbers of loons migrate past Point Barrow between August and October.

Pacific loons. Pacific loons are the most abundant loon species on the ACP (Larned, Stehn, and Platte, 2012), and were recorded in the low hundreds across the Sivulliq study area, out to about 70 kilometers (43 mi) (Figure 3.2.3-1) in September (Morgan, Day, and Gall, 2012). Four were recorded near Foggy Island Bay barrier islands during July in the breeding season (Dau and Bollinger, 2009). Pacific loons are generally thickly distributed in nearshore waters all along the Beaufort Sea coastline in late July and August (Lysne, Mallek, and Dau, 2004).

Red-throated loons. Red-throated loons primarily nest on coastal tundra and on smaller ponds than Pacific or yellow-billed loons. Unique among loons, they foraging in marine waters throughout the nesting season. The red-throated loon's average first arrival date is currently June 2nd. Like other ACP-nesting birds, this date has been shown to be substantially advancing over the past few decades, though at a lesser rate than other types of birds (Ward et al., 2016). Although their ACP breeding density is much lower than for Pacific loons, one identified breeding "hotspot" begins approximately 10 kilometers inland from the Foggy Island Bay coastline (Larned, Stehn, and Platte, 2011). Red-throated loons, with a population index (i.e., abundance uncorrected for visibility rate) of 3,200 on the ACP, are among the few waterbird species with a declining local population (Schmutz, pers. comm., 2017; Stehn, Larned, and Platte, 2013). Only six were recorded in the Sivulliq study area (Figure 3.2.3-1) in September (Morgan, Day, and Gall, 2012).

Yellow-billed loons. Yellow-billed loons migrate along the Beaufort Sea coast in the spring. Their average Colville River Delta first arrival date is currently 1 June, but advancing (USFWS, 2014; Ward et al., 2016). Yellow-billed loon nesting distribution is clumped, with the greatest concentration of ACP nests found inland between the Meade and Colville Rivers (Larned, Stehn, and Platte, 2011). Yellow-billed loons nest on low islands or narrow peninsulas on the edges of large, deep, coastal and inland tundra lakes between 62 and 74 degrees north latitude (USFWS, 2014). Breeding birds typically remain on their lakes until young are fledged.

Yellow-billed loon numbers were thought to be declining (74 FR 12932, March 25, 2009), but the population is now considered stable (Stehn, Larned, and Platte, 2013). An average of approximately 2,200 yellow-billed loons were observed on the ACP in mid-June from 2004 to 2013, with the actual population estimate higher to account for undetected birds (Stehn, Larned, and Platte, 2014; Earnst et al., 2005; Schmutz, 2012). Eight yellow-billed loons were recorded in the breeding season in July in Foggy Island Bay, near mainland coastline and barrier island habitats (Dau and Bollinger, 2009). Twenty of this species were distributed in the Sivulliq study area (Figure 3.2.3-1) in September 2011 (Morgan, Day, and Gall, 2012).

Shorebirds

The ACP is renowned for the abundance and diversity of shorebirds drawn here in the short Arctic summer to breed. Shorebirds are the dominant avifauna on the ACP in terms of both breeding species diversity and abundance (Liebezeit et al., 2009). Most breed on the tundra after arriving in May on the river deltas, relying on coastal areas such as beaches, barrier islands, lagoons, and mudflats for some portion of their lifecycle. Like other birds, shorebirds have been arriving earlier in the spring, correlated with increase in local temperatures and earlier snowmelt in recent decades. Recent ACP shorebird habitat suitability maps show mainland habitat around Foggy Island Bay in the Proposed

Action Area as having among the highest possible levels of predicted breeding shorebird species richness (Saalfeld et al., 2013; ADNR, 2014). Post-breeding, shorebird flocks stage and forage in the hundreds and thousands along the Beaufort Sea coast. This coast is rich with freshwater discharges that produce an estuarine trophic structure and high primary productivity. The flocks feed on invertebrates in the river deltas and mudflats, gravel beaches, and salt marshes to prepare for migration to wintering areas (Powell et al., 2016; Taylor, et al., 2010; Andres, 1994). Species using coastal and nearshore habitats for July – September staging, and likely to occur in the Proposed Action Area, include black-bellied plover (*Pluvialis squatarola*), American golden plover (*P. dominica*), semipalmated plover (*Charadrius semipalmatus*), bar-tailed godwit (*Limosa lapponica*), ruddy turnstone (*Arenaria interpres*), sanderling (*Calidris alba*), semipalmated sandpiper (*C. pusilla*), western sandpiper (*C. mauri*), least sandpiper (*C. minutilla*), stilt sandpiper (*C. himantopus*), pectoral sandpiper (*C. melanotos*), dunlin (*C. alpina*), buff-breasted sandpiper (*C. subruficollis*), long-billed dowitcher (*Limnodromus scolopaceus*), red-necked phalarope (*Phalaropus lobatus*), and red phalarope (*P. fulicarius*). Shorebirds of interest are described below.

Phalaropes

Red phalarope and red-necked phalarope are among the most common ACP breeding shorebird species (Saalfeld et al., 2013; Bart et al., 2012). Phalaropes are unique among shorebirds in that rather than probing in soils while walking, they forage by swimming in nearshore and offshore waters. They primarily eat plankton but do not dive and are restricted to surface foraging. Red and red-necked phalaropes are found in the Beaufort Sea during the open-water season, and are ecologically similar to each other, appearing in mixed flocks, (Kuletz, 2011; Kuletz et al., 2015). Mean Colville River Delta first arrival date for red-necked phalarope is currently May 29th (Ward et al., 2016). Phalaropes are non-territorial, polyandrous breeders that tend to nest in wet tundra on the ACP, and timing of nest initiation may be particularly dependent on snow melt for these species (Liebezeit et al., 2014). In the marine environment, phalaropes are common from pelagic waters to within a few meters of shore. Due to their reliance on zooplankton, their distribution is patchy and variable; because they are tied to a moving prey source, they may be encountered throughout the Beaufort Sea in varying concentrations. They are more common in pelagic Beaufort Sea waters in summer than fall (Kuletz et al., 2015), and about 100 phalaropes were recorded in the Sivulliq study area (Figure 3.2.3-1) in September (Morgan, Day, and Gall, 2012). Some indications of apparent local population decline at individual Arctic sites have been reported for red-necked phalaropes (Andres et. al., 2012).

Sandpipers and other Shorebirds

As noted above, numerous species of sandpipers and other shorebirds nest on the ACP, and many of these use habitat in the immediate vicinity of the Proposed Action Area. Several years of Prudhoe Bay area nest searches found nest densities of semipalmated sandpiper and pectoral sandpiper were rivaled only by Lapland longspur (*Calcarius lapponicus*), a landbird (Streever and Bishop, 2014). Nests of stilt sandpiper, long-billed dowitcher, and dunlin were also regularly found. American golden-plover, ruddy turnstone, and buff-breasted sandpiper were less common but also present. Of the nesting birds found during the Prudhoe Bay surveys ruddy turnstone, often preferring sparsely vegetated coastal salt marsh habitat, is the rarest breeder, with an estimated ACP population of 3,400. Across the ACP the breeding population of semipalmated sandpipers in wetlands is estimated at 50/km² in their preferred wetland habitat and greater than 1,300,000 overall. Pectoral sandpipers are estimated to nest at densities as high as 30/km² and number over 1,000,000 (Bart et al, 2012; Saalfeld et al., 2013).

Buff-breasted sandpiper uniquely among North American shorebirds uses a lek mating system, whereby the male defends (sometimes only briefly and in succession with other males) a relatively small territory he uses only to display and attract females, providing no other resources. The females lay and brood elsewhere in the area. The lek may remain active for days or weeks, but most of the

time is not a location to which birds return to from year to year (Lanctot, pers. comm., 2016; Lanctot and Laredo, 1994). Individual male buff-breasted sandpiper lek behavior and siting can be somewhat opportunistic and adaptable, however, and some lek sites, including near the Endicott Road appear to have been used by the species for multiple years (Lanctot and Weatherhead, 1997; Lanctot et al., 1998; R. Lanctot, pers. comm., 2016). Lekking males tend to use non-patterned ground near streams (Lanctot and Slater, 1992), dissimilar to much of the Proposed Project Area, and no leks have been identified in the Proposed Project Area. The Buff-breasted Sandpiper Conservation Plan (Lanctot et al., 2010), notes that the population, estimated at 40,000 on the ACP (Bart et al., 2012) has apparently substantially declined and is categorized as Near Threatened by IUCN/BirdLife International. Most recently, it has also been categorized as a Bird of High Conservation Concern (HCC) in the U.S. Shorebirds of Conservation Concern - 2016 (U.S. Shorebird Conservation Plan Partnership, 2016). Factors that led to these designations were a small and declining population and relatively small nonbreeding area within which birds concentrate in South America. American golden-plover, dunlin, pectoral sandpiper and semipalmated sandpiper are also on the 2016 list of HCC. The ACP breeding subspecies of dunlin, *C.a. arcticola*, has reportedly declined substantially in recent decades (Andres et al., 2012).

Post-breeding, at least 20 species of shorebirds use the ACP coastline for a different life stage: as staging for and stopovers on southbound migrations (Taylor et al., 2010). The Beaufort Sea coastal river deltas and other littoral habitats are important migratory stopovers for many species of shorebirds—thousands to hundreds of thousands of birds per species (Bart et al., 2012; Taylor et al., 2010; Brown et al., 2007; Churchwell et al., 2016). Semipalmated sandpiper, dunlin, and red-necked phalarope were the most common species observed in the Sagavanirktok River Delta vicinity in late July and August of 2005 and 2006 (Taylor et al., 2010). Brown et al., (2012) proposes that the Sagavanirktok River and Kadleroshilik River function together with the larger Alaskan Beaufort Sea coastal deltas like the Colville River Delta as part of a complex habitat web within which each smaller site is important at various times in preparing shorebirds for their southbound migration.

Landbirds

A variety of landbirds (e.g., raptors and owls, passerines, fowl or game birds) occur in the Proposed Action Area. Some of these are top predators in terrestrial and shoreline areas with which they are associated. A few landbird species occur in the area year-round. Some are significant because they are common breeders in the Proposed Action Area. Finally, many landbird species migrate over the Proposed Action Area, including over marine waters.

Besides owls, a few raptor species breed on the ACP and may be seen in low numbers in the Proposed Project Area. These include Northern harrier (*Circus cyaneus*), rough-legged hawk (*Buteo lagopus*), and Peregrine falcon (*Falco peregrinus*), which all prey to some extent on other birds. They are territorial breeders, occur on the ACP only during the breeding season, and occasionally nest on oilfield infrastructure.

Common raven (*Corvus corax*) is expected to occur in the Proposed Action Area coastal and terrestrial zones. This large passerine is a generalist scavenger and also a predator on the young and eggs of other birds during the breeding season. Ravens are attracted to landfill food sources and occur year-round on the ACP (Saalfeld, Hill, and Lanctot, 2013). Geese, duck, and ptarmigan have been among the types of avian remains identified in a study of raven diet on the Prudhoe Bay oilfields, approximately 40 kilometers (25 mi) to the west of the Proposed Project Area (Powell and Backensto, 2009). Ravens prefer to breed on cliffsides and other elevated areas. Only in recent decades, as communication and oil field infrastructure increased, have ravens noticeably expanded their breeding range onto the relatively flat-featured ACP. Both the number of raven sightings during the winter Audubon Christmas Bird Count, and the number of raven nests in summer have increased over the

recent years of study (1987-2012 and 2004-2014, respectively) on the Prudhoe Bay oilfields (including existing artificial drilling islands Endicott SDI and Northstar) (Bishop and Streever, 2016).

Another landbird predator likely to occur in the Proposed Action Area coastal zone year-round is snowy owl (*Bubo scandiacus*). Snowy owl is an important Arctic predator on small mammals, especially lemmings, and the young of other birds during breeding season. Therrien, Gauthier, and Bêty (2011) describe how snowy owls should be considered a marine species with their common venturing out over the pack ice. Gall and Day (2012) report a short-eared owl (*Asio flammeus*) at the Burger prospect in the Chukchi Sea in August 2009, at least 60 miles from shore. Seven snowy owls were observed in July around Foggy Island Bay, including six associated with Tigvariak Island (Dau and Bollinger, 2012). Ptarmigan species, particularly rock ptarmigan (*Lagopus mutus*), which prefer open tundra and breed in alpine and Arctic tundra, are common fowl on the ACP year-round.

Several species of passerine birds (also called songbirds) breed in Arctic habitats in the U.S., Canada, and Russia, and migrate across the Beaufort Sea to and/or from their wintering grounds. Two common breeders on the ACP include Lapland longspur and snow bunting (*Plectrophenax nivalis*). Like all Alaskan ground-nesting passerines, the nests of these small birds are camouflaged and easily overlooked, despite their abundance. They both arrive on the ACP breeding grounds early in spring, snow bunting being one of the first Colville River Delta arrivals with a current mean arrival date of April 17th (Ward et al., 2016).

Passerines interact with at-sea oil and gas industry vessels, often hundreds of miles from land. Arctic passerine migrations are usually nocturnal and have not generally been well-studied, but it is well-known that these long-distance flights are occurring both for species that winter in North America (“New World” migrants), as well as some that breed and/or winter on other continents (commonly referred to as “Old World” migrants). Passerine flights in the Arctic are sometimes “off-course” migrants, and other times very large flocks. Over 40% of the bird encounters recorded on drilling and support vessels during 2012 and 2015 exploration drilling in the Chukchi Sea were passerines, including three species of Old World migrants- Arctic warbler (*Phylloscopus borealis*), northern wheatear (*Oenanthe oenanthe*), and yellow wagtail (*Motacilla tschutschensis*), American pipit (*Anthus rubescens*), yellow warbler, (*Dendroica [Setophaga] petechia*), Swainson’s thrush (*Catharus ustulatus*), dark-eyed junco (*Junco hyemalis*), rusty blackbird (*Euphagus carolinus*), a “sparrow” (Family Passeridae), four birds described as “warblers” (a vague term that could be applied to any number of small perching birds), and nine other individuals that were not or could not be identified to species but were (based on photographs) probably passerines (Shell, 2012, 2015). Given the large proportion of passerines and multiple numbers of strikes far from shore in adjacent Arctic waters, many of the passerine species are expected to also fly in or near the Proposed Action Area.

3.2.4. Marine Mammals

This section provides information on marine mammal species that may be present in or near the Proposed Action Area, and includes those currently listed as threatened or endangered, or as candidate species under the ESA. Threatened and endangered marine mammal species in the Proposed Action Area include the bowhead whale, bearded seal, and polar bear. The only documentation of humpback whales (presently listed as endangered) occurred in during a Bowhead Whale Aerial Survey Program (BWASP) flight in 2008 west of the Colville River Delta. Since this was the only record of a humpback whale in the Beaufort Sea, the sighting is considered extralimital and this species will not be discussed further in this DEIS. Pacific walrus, while uncommon in the Proposed Action Area, is a candidate species under the ESA and will be considered here. Other species of marine mammals occurring in the Beaufort Sea include beluga whales, gray whales, and spotted and ringed seals.

Minke, humpback and fin whales, killer whales, harbor porpoises, and ribbon seals regularly occur in the Chukchi Sea but not in the Beaufort Sea. Narwhals, Steller sea lions, and hooded seals are considered extralimital to the Proposed Action Area and will not be discussed in this DEIS.

Acoustic Environment

The underwater and terrestrial acoustic environment is particularly important to marine mammals since marine mammals use noise to navigate, find prey, communicate, and detect disturbances or threats. While cetaceans typically rely on underwater acoustics, pinnipeds and polar bears freely perceive noises in and out of the water, such as when individuals are hauled out, spy-hopping, or traveling across the sea ice as is the case with polar bears.

In the Beaufort Sea, natural sources of marine sound include wind stirring the surface of the ocean, storms, ice movements, and animal vocalizations and noises (including whale calls and echolocation clicks). The frequency and magnitude of noise from each of these producers can differ dramatically within and among years as a result of variation in the seasonal presence of the sound sources. Existing human sources of sound in the Beaufort Sea include vessels (motor boats used for subsistence and local transportation, commercial shipping, research vessels, etc.); navigation and scientific research equipment (e.g., benthic trawls); airplanes and helicopters; human settlements; military activities; and offshore industrial activities. Burgess and Greene (1999) measured the overall ambient sound in the Beaufort Sea in September 1998 to be approximately 63 to 133 dB re 1 μ Pa. Within Foggy Island Bay, ambient sound levels during the open-water season are typically higher offshore (Frouin-Mouy, Zeddies, and Austin, 2016).

Physical Environment Sound Sources

The Proposed Action Area is covered by sea ice during much of the year (see Section 3.1.2.4, Sea Ice). Sea ice can both produce substantial amounts of ambient noise and act as a damper (Richardson et al., 1995). Particularly in very shallow water, ice reduces the transmission efficiency of low frequency sounds (Blackwell and Greene, 2001). Temperature changes can result in cracking; cracking ice produces sounds across a broad range of frequencies, typically from 100 Hertz (Hz) to 1 kiloHertz (kHz) and can vary as much as 15 dB within 24 hours in response to diurnal changes in air temperature (USDOJ, BOEM, 2011). Greene (1981) documented frequencies from 4 to 200 Hz produced by ice deformation. The types of sea ice (e.g., broken, shorefast) and its movement, as well as air temperature and wind speed all influence the ambient sound levels ice produces (Richardson et al., 1995). Ambient sound levels in the Proposed Action Area are lower in winter. At frequencies less than 50 Hz, Greene (1997) found the difference between summer and winter ambient sound levels in the area was approximately 10 dB.

Wind and waves are a dominant source of ambient noise during the open-water season (Greene and Moore, 1995). Wind, wave, and precipitation noise originating close to the point of measurement dominate frequencies from 500 Hz to 50 kHz (Richardson et al., 1995). Ambient noise levels are greater in the marginal ice zone, due in large part to wave action against the ice edge and because of the breaking up and movement of ice floes (Milne and Ganton, 1964). Greene (1998) used seafloor recorders that measured sounds at frequencies between 20 and 5,000 Hz to measure open-water ambient underwater sound levels in Stefansson Sound near the Proposed Action Area. The median sound pressure level measured over 44 days was 97 dB re 1 μ Pa based on samples of sounds averaged over 30 seconds; the 5th and 95th percentiles were 78 and 110 dB re 1 μ Pa, respectively. The values reported in Greene (1998) are consistent with measurements collected during acoustic monitoring of a seismic survey near the Proposed Action Area in the summer of 2008, which yielded ambient sound levels at frequencies from 10 to 450 Hz with 5th and 95th percentile levels of 70 and 100 dB re 1 μ Pa, respectively (Aerts et al., 2008). The most recent ambient sound measurements for Foggy Island Bay, measured during the 2015 open-water season, showed median levels of 96 to 98 dB re 1 μ Pa; 10% of

the time the sound levels exceeded 104 dB re 1 μ Pa to 108 dB re 1 μ Pa (Frouin-Mouy, Zeddies, and Austin, 2016).

Biological Sound Sources

Marine mammals can contribute to the background sounds in the acoustic environment of the Beaufort Sea; frequencies and levels are highly dependent on seasons. For example, source levels of bearded seal songs have been estimated to be up to 178 dB re 1 μ Pa at 1 m (Ray et al., 1969; Stirling, 1983; Richardson et al., 1995; Thomson and Richardson, 1995). Ringed seal calls have a source level of 95-130 dB re 1 μ Pa at 1 m, with the dominant frequency under 5 kHz (Stirling, 1973; Cummings et al., 1986; Thomson and Richardson, 1995). Bowhead whales in western Greenland waters produced songs of an average source level of 185 ± 2 dB rms re 1 μ Pa at 1 m centered at a frequency of 444 ± 48 Hz (Roulin et al., 2012).

Existing Human-generated Sound Sources

Levels of anthropogenic (human-caused) sound can vary dramatically depending on the season, type of activity, and local conditions. In the U.S. Beaufort Sea, primary sources of anthropogenic sound are vessels and oil and gas exploration, development, and production activities. Anthropogenic noise levels in the Beaufort Sea region are higher than the Chukchi Sea due to the oil and gas developments of the nearshore and onshore regions of the North Slope, particularly in the vicinity of Prudhoe Bay. Noise levels from open-water oil and gas exploration activities in the U.S. Beaufort Sea have been measured since 2006 as required by regulatory permits (2015 Hilcorp EIA, Section 3.5.2).

Vessels. Vessel traffic and associated noise is limited primarily to late spring, summer, and early autumn at the present time. The types of vessels operating in the vicinity of the Proposed Action Area include barges, skiffs with outboard motors, icebreakers, tourism and scientific research vessels, and vessels associated with oil and gas exploration, development, and production (e.g., seismic vessels, crew-transfer vessels). Shipping sounds are often at source levels of 150-190 dB re 1 μ Pa at 1m (USDOJ, BOEM, 2011). Shipping traffic is mostly at frequencies from 20-300 Hz (Greene and Moore, 1995). Sound produced by smaller boats typically is at a higher frequency, around 300 Hz (Greene and Moore, 1995). In shallow water, vessels more than 10 kilometers (6.2 mi) away from a receiver generally contribute only to background-sound levels (Greene and Moore, 1995). Measured noise from vessels associated with a 2008 seismic survey for the Proposed Action Area decayed to levels of 120 dB re 1 μ Pa rms SPL within ranges less than 0.2 miles from the vessels and decayed to levels of 100 dB re 1 μ Pa rms SPL at ranges less than 0.6 miles (Aerts et al., 2008). The daily average sound attributable to passing vessels during geohazard surveys in Foggy Island Bay from July 6 to September 22, 2015 was ~ 138 dB SEL (sound exposure level) at 500 meters from the end of the offshore end of the survey line and ~ 154 dB SEL at 5000 meters from the end of the offshore survey line (Frouin-Mouy, Zeddies, and Austin, 2016). In both cases the range of sound energy from vessels could almost encompass the range of average daily SEL; meaning that when one or more vessels were present, vessel-associated noise could dominate the nearby ambient soundscape. Sound levels were typically higher farther offshore and the differences in acoustic energy attributable to passing vessels indicates that vessel noise likely accounts for most of the difference in ambient sound energy levels between nearshore and offshore portions of the survey area (Frouin-Mouy, Zeddies, and Austin, 2016).

Oil and Gas Activities. Industrial activities that introduce sound into the environment include geophysical seismic surveys, and oil and gas exploration, development, production, and decommissioning activities, including construction of and travel on ice-roads and other on-ice activities that occur throughout the winter.

Two-dimensional (2D) seismic surveys have been conducted in the Beaufort Sea since the late 1960s, resulting in extensive coverage over the area. Seismic surveys vary, but a typical deep 2D or three-

dimensional (3D) seismic survey using airgun arrays comprised of multiple guns would emit sound at frequencies of about 10-120 Hz, and pulses can contain some sound energy up to 500 Hz to 1 kHz (Greene and Moore, 1995). Seismic airgun sound waves are directed downwards, but can project sound pulses horizontally that can be detected many kilometers away (Greene and Richardson, 1988; Greene and Moore, 1995). Analysis of sound associated with seismic operations in the Beaufort Sea and central Arctic Ocean during ice-free conditions also documented propagation distances up to 1300 kilometers (Richardson, 1998, 1999; Thode et al., 2010). While seismic energy does have the capability of propagating for long distances, it generally decreases to a level at or below the ambient noise level at a distance of 10 kilometers from the source (Richardson, 1998, 1999; Thode et al., 2010). Aerts et al. (2008) indicated that distant airgun sounds from unrelated surveys were detectable within the Proposed Action Area.

Greene and Moore (1995) summarized that typical signals associated with vibroseis sound source used for on-ice seismic surveys sweep from 10-70 Hz, but harmonics extend to about 1.5 kHz.

In state waters of the Beaufort Sea, there are three operating oil production facilities (Northstar, Ooguruk, Nikaitchug) on manmade gravel islands and two production facilities on a manmade peninsula/causeway. Much of the production noise from oil and gas operations on gravel islands is substantially attenuated within 4 kilometers (2.5 mi) and often not detectable beyond 9.3 kilometers (5.8 mi) away (NMFS, 2014). Studies conducted as part of a monitoring program for the Northstar project (a drilling facility located on an artificial island in the Beaufort Sea) indicate that in one of the 3 years of monitoring efforts, the southern edge of the bowhead whale fall migration path may have been slightly (2-3 mi) further offshore during periods when higher sound levels were recorded; there was no significant effect of sound detected on the migration path during the other two monitored years (Richardson et al., 2004). Evidence indicated that deflection of the southern portion of the migration in 2001 occurred during periods when there were certain vessels in the area and did not occur as a result of sound emanating from the Northstar facility itself (USDOJ, BOEM, 2011).

Other Sound Sources. Aircraft traffic associated with research activities and oil and gas activities occurs in the Beaufort Sea in all seasons. The level and duration of sound received underwater from aircraft depends on altitude and water depth (NMFS, 2014). Received sound level decreases with increasing altitude. For a helicopter operating at an altitude of 1,000 ft (305 m), there were no measured sound levels at a water depth of 121 ft (37 m) (Greene, 1985).

Acoustic systems may be used in the Arctic by researchers, military personnel, or commercial vessel operators. These include high-resolution geophysical equipment, acoustic Doppler current profilers, mid-frequency sonar systems, and navigational acoustic pingers (LGL, 2005, 2006). These active sonar systems emit transient sounds that vary widely in intensity and frequency (USDOJ, BOEM, 2011).

Table 3.2.4-1. Boxcar Frequency Ranges for Marine Mammal Functional Hearing Groups¹.

Species Group	Lower Limit (Hz)	Upper Limit (Hz)
Low Frequency (LF) Cetaceans	7	35,000
Mid Frequency (MF) Cetaceans	150	160,000
High Frequency (HF) Cetaceans	275	160,000
Orariid Pinnipeds, Walruses, Sea Otters, Polar Bears (in water)	60	39,000
Phocid Pinnipeds, Sirenians (in water)	50	86,000

Note: ¹Frequency range determined using NMFS (2016) data.

To varying degrees, marine mammals use hearing, sight, smell, and touch to interact with their environment. For practical purposes marine mammals have been separated into a few hearing groups based on the results from decades of scientific investigations (Southall et al., 2007; Finneran and Jenkins, 2012, NMFS, 2016) which are depicted in Table 3.2.4-1. More species-specific descriptions of sensory perceptions are provided in the following discussion of resident marine mammal species.

3.2.4.1. Cetaceans

Beluga, bowhead, and gray whales are the only cetaceans likely to occur in the Proposed Action Area. The NMFS Stock Assessment Reports (SAR) and species-specific web sites contain up to date and detailed information on the status, distribution, abundance, and life history of each of the cetacean species mentioned in this document. The newest SARs for these species (Carretta et al., 2015, Allen and Angliss, 2015) are available at: <http://www.nmfs.noaa.gov/pr/sars/species.htm>. Web sites updated by NMFS with information specific to these species can be found at <http://www.fisheries.noaa.gov/pr/species/mammals/>

Odontocete Whales

The only toothed whale (Odontocete) likely to occur in the Proposed Action Area is the beluga (*Delphinapterus leucas*).

Beluga Whale

Population and status

Five stocks (subpopulations) of beluga whales occur in the waters of Alaska: Cook Inlet, Bristol Bay, Eastern Bering Sea, Beaufort Sea (BS), and Eastern Chukchi Sea (ECS) stocks (Allen and Angliss, 2015). These stocks were tentatively identified by their summer distributions (Frost and Lowry, 1990; Richard, Martin, and Orr, 2001), and were later confirmed genetically (O’Corry-Crowe et al., 1997, 2002, 2010). Beluga whales in Alaska appear to follow one of two life history strategies: migratory and nonmigratory. Migratory stocks use shallow nearshore and deepwater offshore habitats (Hazard, 1988; Frost and Lowry, 1990), and include the ECS and the BS stocks; the only two beluga whale stocks that may occur in the Action Area.

The current minimum population estimate for beluga whales in the ECS stock is 3,710 individuals based on 1989-1991 aerial surveys (Frost, Lowry, and Carroll, 1993; Allen and Angliss, 2015). Aerial surveys were conducted in the summer of 2012 in the northeastern Chukchi and Alaskan Beaufort seas in late June through August (Clarke et al., 2013) but these data are still currently being analyzed. The current population trend for the eastern Chukchi Sea beluga stock is unknown (Allen and Angliss, 2015).

The current minimum population estimate for beluga whales in the BS stock is 32,453 individuals based on surveys completed in 1992 (Allen and Angliss, 2015). Trend data from the Mackenzie River Delta indicate the BS stock is at least stable or increasing (Harwood and Kingsley, 2013 in Allen and Angliss, 2015). All populations of belugas whales are protected under the MMPA but neither the BS nor ECS stock is listed under the ESA.

Distribution ECS

Beluga whales are found throughout seasonally ice-covered Arctic and subarctic waters of the Northern Hemisphere (Gurevich, 1980), and are closely associated with open leads and polynyas in ice-covered regions (Hazard, 1988). Depending on season and region, beluga whales may occur in both offshore and coastal waters. The distribution of beluga whales in Alaska is discontinuous from Yakutat Bay to Cook Inlet to Bristol Bay. The area from Bristol Bay northward and eastward to Canada is used by belugas; the Bering and Chukchi seas are used year-round and the Beaufort Sea is used in summer (Frost and Lowry, 1990).

Both ECS and BS beluga whale stocks winter in the southern Chukchi Sea and Bering Sea (Suydam et al., 2001; Miller, Elliott, and Richardson, 1998; Muto et al., 2016) however, there is some evidence that the stocks may use separate wintering locations (Suydam, 2009). Migration north through the Chukchi Sea and east through the Beaufort Sea is stock-specific, with BS migration occurring in spring and ECS in summer.

Satellite telemetry data indicate that summering BS belugas tagged in the Mackenzie River Delta (Canada) stayed in the Canadian Beaufort Sea for the entire month of July and most of August, in an area from the delta east into Amundsen Gulf and north to Viscount Melville Sound (Richard, Martin, and Orr, 2001). Beluga whales migrating in the fall from the Canadian Beaufort Sea transit the U.S. Beaufort Sea in a dispersed pattern, along the southern edge of the pack ice over the continental shelf break, to reach western Chukchi Sea waters primarily during September (Richard, Martin, and Orr, 1997; 2001). During this time, pods can number 500-1,000 individuals (Lowry, 1994; Citta and Lowry, 2008). Occasionally, a few appear in coastal areas and river deltas.

Belugas in the ECS Stock calve, feed, and molt in June and July near Kasegaluk Lagoon, between Cape Lisburne and Icy Cape, Alaska (Frost and Lowry, 1990; Frost, Lowry, and Carroll, 1993; Suydam et al., 2001). ECS belugas tagged in Kasegaluk Lagoon have been tracked in July through November from 130° W to 176.5° W and north to 81° N (Suydam et al., 2001; Suydam, Lowry, and Frost, 2005; Citta et al., 2013). This suggests that belugas sighted during aerial surveys in the northeastern Chukchi Sea and western Beaufort Sea from June through August are likely ECS belugas (Hauser et al., 2014). However, during the return migration in September and October, BS belugas overlap with ECS belugas in the western Beaufort Sea (Hauser et al., 2014).

Distribution of belugas may be impacted by age and sex. Analysis of mitochondrial DNA indicates that beluga whale adults in the western North American stocks are stratified by age (O’Corry-Crowe et al., 1997). Older adult males tend to disperse more (O’Corry-Crowe et al., 1997; Suydam, Lowry, and Frost, 2005). These patterns are supported by a study on movement patterns of tagged ECS belugas in Kasegaluk Lagoon, near Point Lay (Suydam, Lowry, and Frost, 2005). Although belugas of all ages and both sexes were most often found in water deeper than 200 meters along and beyond the continental shelf break, adult males moved farthest away from shore and remained there longest, females moved the shortest distance, and immature males showed intermediate movement (Suydam, Lowry, and Frost, 2005). BS belugas tagged in the eastern Beaufort Sea also showed age and sex differences in their habitat use; females with calves and younger males selected open-water habitats near the mainland and older males selected closed sea ice cover in and near the Arctic Archipelago (Losteo et al., 2006).

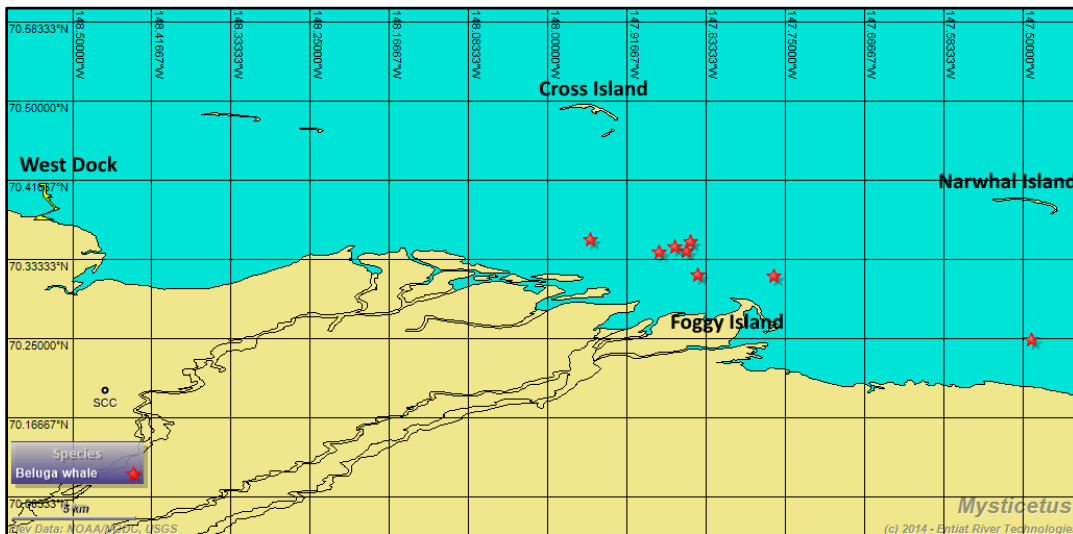

Figure 3.2.4-1. Liberty area Beluga Whale Sightings – 2014. Locations of beluga whale sightings made by PSOs from vessels during the Liberty 2014 Survey (Smultea et al., 2014).

In interviews summarizing Traditional Knowledge (TK), beluga whale hunters in the eastern Chukchi and northern Bering seas also indicated that groups composed of different age and sex classes of belugas migrated at different times, and thus arrived at harvest areas (e.g., Escholtz Bay) at different

times. First, subadult belugas migrated along the ice edge in spring, females with calves and young whales followed, and large males migrated along the ice edge last (Huntington et al., 1999). Hunters reported that tidal movements of belugas in and out of Escholtz Bay were led by large adult males (Huntington et al., 1999). Data on age composition and sex ratio of beluga whales in Alaska are scant and age composition may vary by geographic area.

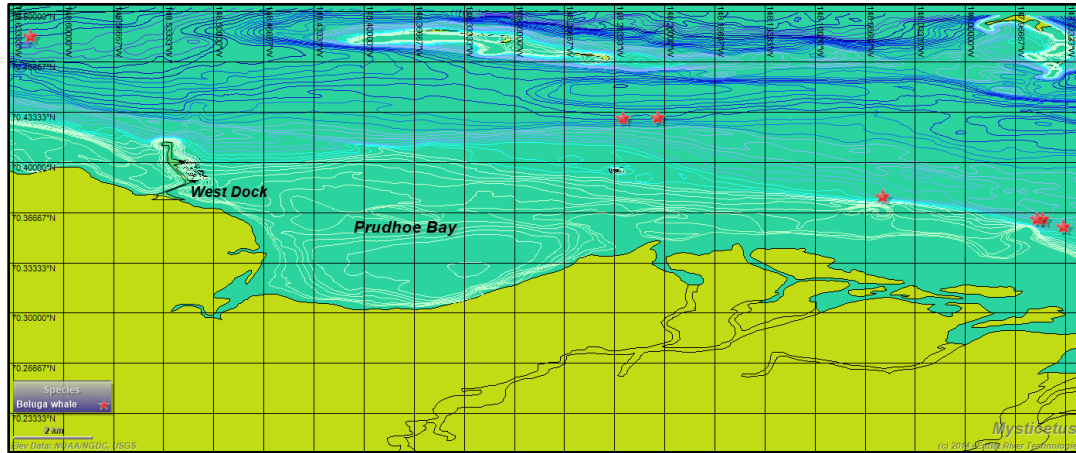

Figure 3.2.4-2. Beluga Whale Locations. Locations of beluga whale groups seen by PSOs during the 2014 BPXA seismic survey (Lomac-MacNair et al., 2015).

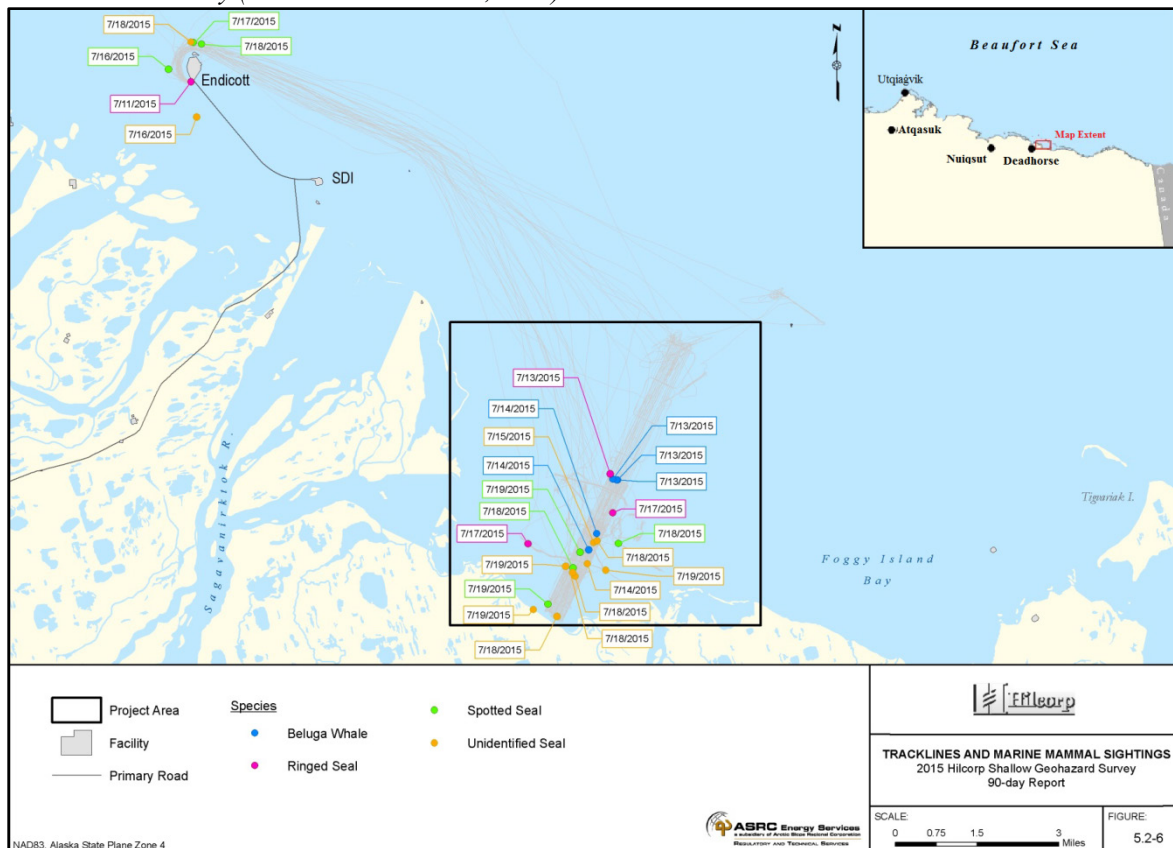

Figure 3.2.4-3. Foggy Island Bay Beluga Whale Sightings – 2015. Locations of beluga whales (blue dots) seen by PSOs in Foggy Island bay during the 2015 HAK geohazard surveys (Cate et al., 2015).

During the 2014 open water season, BPXA conducted a two-dimensional (2D) high-resolution (HR) shallow geohazard survey followed by a seabed sonar mapping survey in the Proposed Action Area. Marine mammal monitoring surveys were conducted in association with this operation. The surveys

began on July 16 and were completed by August 30, 2014. During that time, eight groups of approximately 19 individual beluga whales, five of which were juveniles, were seen in the area (Figures 3.2.4-1 and 3.2.4-2); some of these were considered re-sights (Smultea et al., 2014).

During the 2014 open-water season (beginning July to mid-September), BPXA also conducted a marine mammal monitoring survey during their three-dimensional (3D) ocean bottom sensor seismic operations in the North Prudhoe Bay area. The survey location was in the U.S Beaufort Sea approximately 30 miles west of the Proposed Action Area. During the survey, seven groups of approximately 15 individual beluga whales were observed (Figure 3.2.4-2), including three calves; some of these were considered re-sights (Lomac-MacNair et al., 2015).

HAK conducted a marine mammal monitoring survey in 2015 during their open-water season shallow geohazard and strudel scour survey operations in the Proposed Action Area in Foggy Island Bay (U.S Beaufort Sea). Observations for marine mammals were conducted July 9 through July 19, 2015. Five beluga observations were made in Foggy Island Bay (Figure 3.2.4-3) though it was thought this was the same beluga seen on multiple occasions (Cate et al., 2015).

Aerial surveys for marine mammals have occurred annually from 1979-2015 in the summer and fall in the western Beaufort Sea. These surveys are currently known as the Aerial Surveys of Arctic Marine Mammals (ASAMM) project, funded by BOEM and conducted by NOAA. Historically, no belugas have been observed in the Proposed Action Area during ASAMM surveys; most belugas are observed along the continental shelf (Figure 3.2.4-4). However, belugas have been seen immediately north of the Proposed Action Area and seaward of the barrier islands (Figure 3.2.4-5). In general, beluga distribution in the ASAMM survey area, south of 72°N, has remained remarkably similar over the past 30 years (Clarke et al., 2015a).

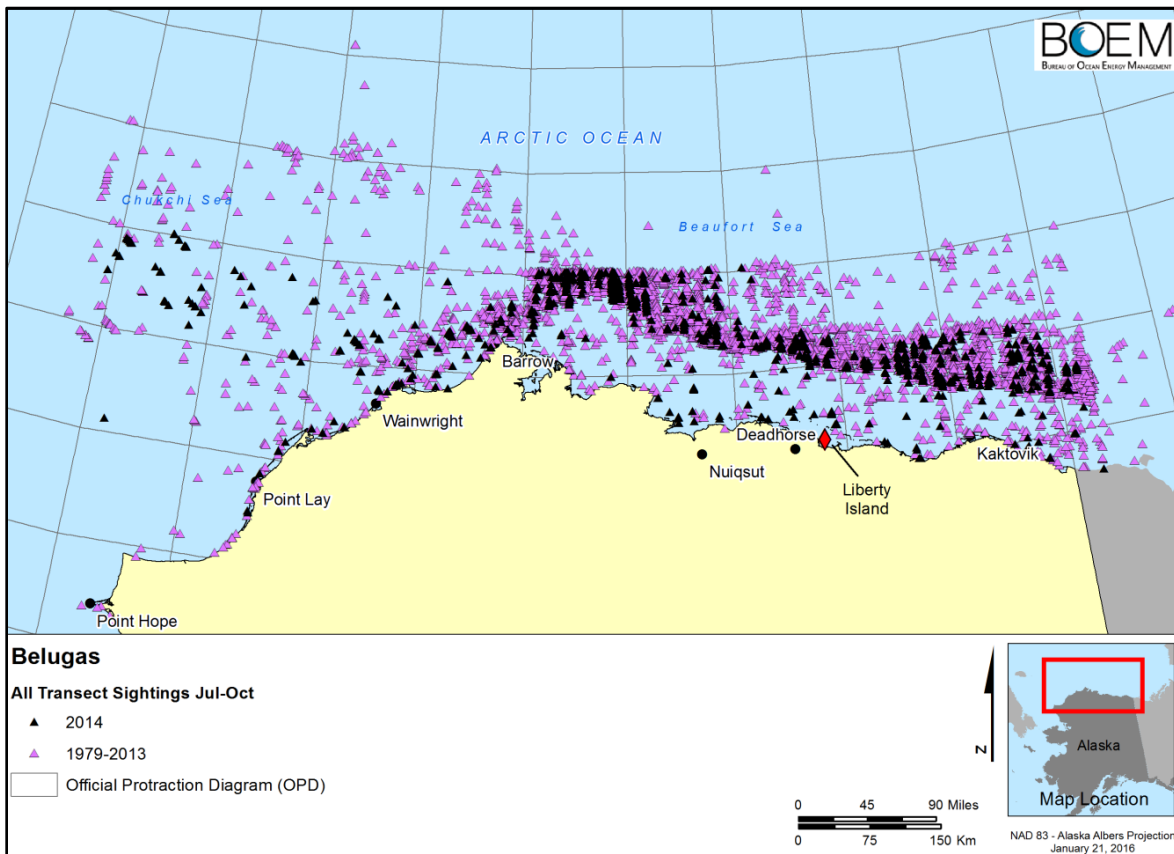

Figure 3.2.4-4. Belugas seen in the U.S Arctic during ASAMM surveys 1979-2014.

The 2014 (July-October) survey data gathered by ASAMM found that beluga distribution in the western Beaufort Sea in summer and fall was centered over the continental slope and Barrow Canyon, north and west of the Proposed Action Area, with more sightings than usual in shallow nearshore areas (Figure 3.2.4-5). Beluga calf sightings were scattered across the western Beaufort Sea slope, although a few were seen seaward of barrier islands (Clarke et al., 2015a). In 2014, neither adults nor calves were seen in the Proposed Action Area or inside barrier islands, although some were outside of the barrier islands to the north of the Proposed Action Area (3.2.4-4). Although none were seen during ASAMM surveys, a few belugas were seen inshore of barrier islands in the central U.S. Beaufort Sea (approximately 30 miles west of the Proposed Action Area) during the BPXA 2014 surveys from late July to late September 2014 (Lomac-MacNair et al., 2015).

Kuletz et al. (2015) examined seasonal spatial patterns in seabird and marine mammal distribution in the eastern Chukchi and western Beaufort seas to identify biologically important pelagic areas. To identify marine mammal hotspots, data from the ASAMM surveys from mid-June through late October of 2007–2012 were used. Hotspots for belugas occurred in both the Chukchi and Beaufort seas. They found that the locations of hotspots varied among species but often were located near underwater canyons or over continental shelf features and slopes. Shared hotspots were characterized by strong fronts caused by upwelling and currents, which may have high densities of euphausiids (krill) in summer and fall. Belugas were distributed more widely than bowhead whales and had higher relative abundance in summer than in fall. No hotspots were identified close to or in the Proposed Action Area.

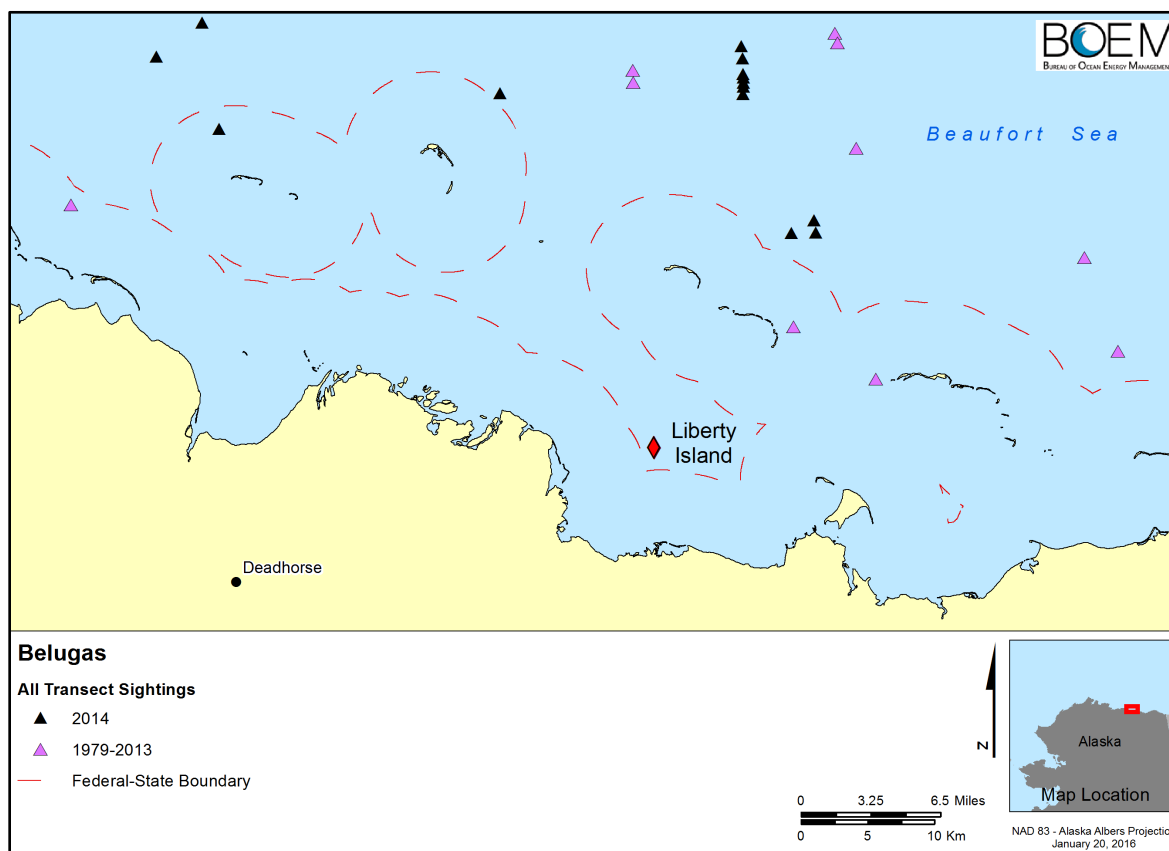

Figure 3.2.4-5. Belugas near the Proposed Action Area during ASAMM surveys 1979-2014.

Clarke et al. (2015b) evaluated Biologically Important Areas (BIAs) for belugas in the U.S. Arctic region and identified three. Both the spring (April-May) and fall (September-October) migratory corridor BIAs for belugas are far north of the Proposed Action Area because sightings of belugas

from aerial surveys in the western Beaufort Sea are primarily on the continental slope, with relatively few sightings on the shelf (Clarke et al., 2015b). Clarke et al. (2015b) also identified one combined BIA for belugas important for both reproduction and feeding; between Cape Lisburne and Icy Cape in the Chukchi Sea. No reproductive and feeding BIAs were identified in the Beaufort Sea for belugas.

From these collective data discussed above, beluga whale occurrence in the Proposed Action Area is considered very limited. However, a few beluga whales would be expected to be found within the Proposed Action Area during open-water season.

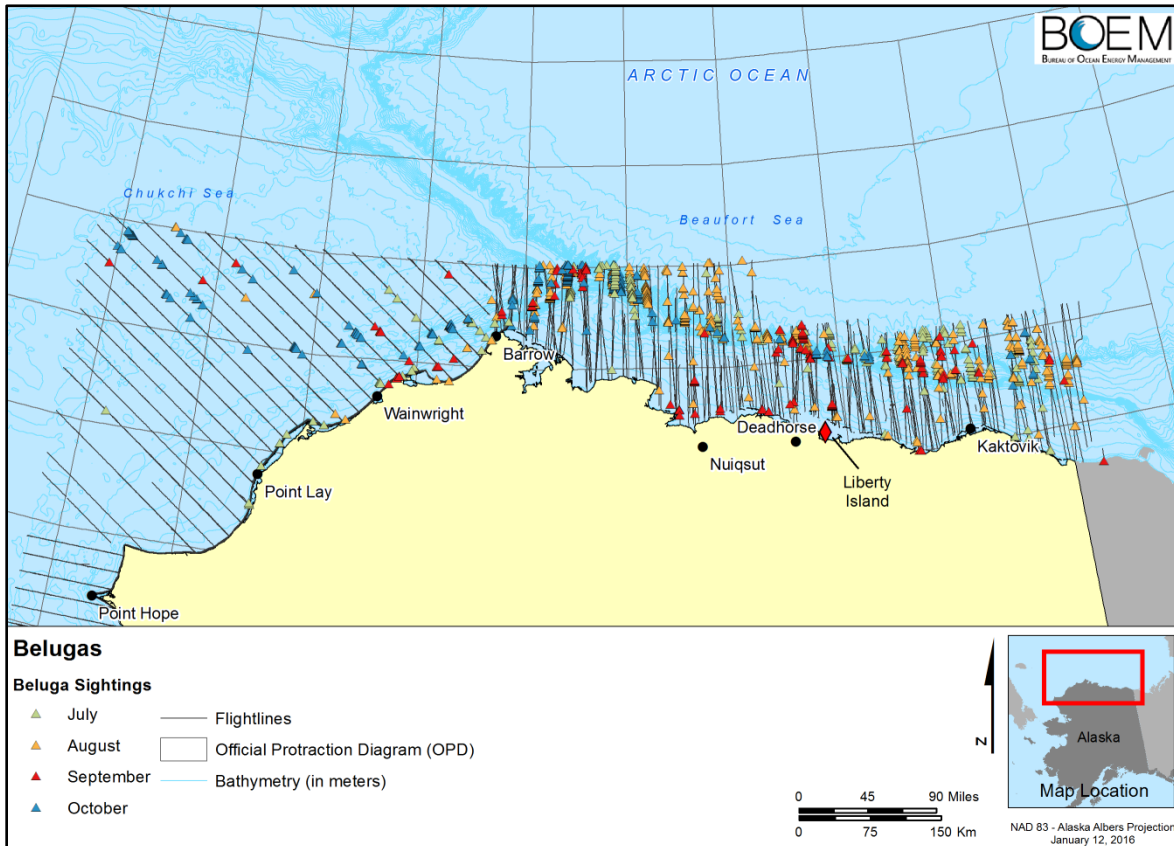

Figure 3.2.4-6. Belugas seen in the U.S Arctic during 2014 ASAMM surveys by month.

Life History

Knowledge of beluga whale social behavior, including the time and place of mating, is limited because inclement weather and ice cover preclude whale observations during part of the year (Brown Gladden et al., 1999). Conception most likely occurs in early spring while belugas are at their wintering areas or during the spring migration, as early as mid-March to early June (Brodie, 1971; Sergeant, 1973; Burns and Seaman, 1985; Brown Gladden, Ferguson, and Clayton, 1997). However, O’Corry-Crowe et al. (1997) indicate that mating occurs in the Eastern Beaufort stock between April and July. Adult male beluga whale behavior in mating seasons is consistent with a polygamous mating system in which males compete directly for access to females (O’Corry-Crowe et al., 1997). The overall sex ratio of beluga whales in Alaska is 1:1; however, subsampling of the dataset used in the sex ratio study showed large deviations in sex ratio by area (Burns and Seaman, 1985).

Beluga whales may live more than 60 years (Burns and Seaman, 1985). Female belugas may reach reproductive maturity between four and 10 years of age, and males may reach reproductive maturity between eight and 15 years of age (Nowak, 1991 in NMFS, 2008; Suydam, 1999; Lockyer et al., 2007; NMFS, 2008). Gestation lasts 14 to 14.5 months, with single calves born in late spring or early

summer (NMFS, 2008). Beluga whale calves may nurse for up to two years. Older calves and subadults may, however, remain closely associated with mothers much longer than two years (O’Corry-Crowe et al., 2002).

Beluga whales change color from gray to white as they mature, reaching white coloration between ages 12 and 17 (Brodie, 1971; Sergeant, 1973) although Burns and Seaman (1985) reported gray females up to 21 years of age. McGuire et al. (2008) photo-identified ten gray beluga whale mothers with calves in Cook Inlet. Because this color change appears not to occur at a standard age and may not indicate reproductive maturity, age-class (individuals of the same age range) for belugas is typically inferred from a combination of relative body size and coloration.

The beluga whale is a highly social species that exhibits substantial variation in geographic movement patterns and in group structure (O’Corry-Crowe et al., 1997). Beluga whales typically migrate, hunt, and interact together. Nowak (1991) reported an average group size of 10 animals, although beluga whales may occasionally form larger groups, during migrations (Huntington, 1999). Native hunters have stated that beluga whales form family groups (Huntington, 2000). Behavior of groups of belugas, such as seasonal movements and occurrence of aggregations, may differ by age and sex of group members, group size, and environmental variables (e.g., tides, prey distribution, predation) (Hazard, 1988; O’Corry-Crowe, 2009).

The smaller toothed cetaceans, such as belugas, produce sounds across some of the widest frequency bands that have been observed in animals (Southall et al., 2007). Their social sounds are generally in the range audible to humans, from a few hundreds of Hz to several tens of kHz, but specialized clicks used in biosonar (echolocation) systems for prey detection and navigation extend well above 100 kHz (Southall et al., 2007).

Beluga whales also have a well-developed sense of directional hearing. They can hear across a large range of frequencies, from about 40–75 Hz to 80–150 kHz (Richardson, 1995). Their hearing is most acute at middle frequencies, between about 10 and 75 kHz (Fay, 1988; Richardson, 1995). Therefore, beluga whales are grouped in the mid-frequency cetacean hearing group with an estimated auditory bandwidth of between 150 Hz to 160 kHz (Southall et al., 2007) and in a the boxcar frequency range of 50 Hz-200 kHz (Finneran and Jenkins, 2012, Ciminello et al., 2012). Sound reception is through the lower jaw, which is hollow at its base and filled with fatty oil. Sounds are conducted through the lower jaw to the middle and inner ears, then to the brain (NMFS, 2008).

Beluga whales use echolocation for directional voice and hearing capabilities (Penner, Turl, and Au, 1986). The beluga whale’s ability to emit and receive signals off the water’s surface and to detect targets in high levels of ambient noise and backscatter enable the animals to navigate through heavy pack ice, as well as locate areas of ice-free water and possibly even find air pockets under the ice (Turl, 1990). If a noise source between a beluga and its target is too high to use straight-line echolocation, the beluga can redirect and bounce its echolocating beam off the water’s surface. This ability to alter its emitted pulses in a different direction allows the beluga to successfully locate its target in the presence of other noise sources (Penner, Turl, and Au, 1986). Dive profiles indicate belugas may use sound while diving to locate cracks in the ice above (Martin, Smith, and Cox, 1998).

Knowledge about visual capabilities of the beluga whale is very limited; observations of beluga whales in captivity led to a conclusion that they have rather good visual capabilities (Pilleri, 1982; Marino and Stowe, 1997). However, laboratory investigations suggest that the beluga whale has slightly poorer visual acuity than other marine odontocetes (Mass and Supin, 2002). Their retinas contain both rod and cone cells, so they are believed to see color (Dawson, 1980). Recent immunocytochemical, physiological, and molecular genetic data, however, demonstrate an absence of blue-sensitive cones in the eyes of whales and seals, indicating cone monochromacy and, hence, serious deficits in—or even the absence of—color vision (Griebel and Peichl, 2003).

Diet and feeding

Belugas have been known to hunt individually and in a group cooperatively. During foraging, belugas may be able to maintain communication with other belugas over areas of 300 m–500 meters (Bel'kovich and Sh'ekotov, 1992). For beluga whales, foraging usually begins with a deliberate movement synchronized with acoustic localization of prey. Short periods of rapid swimming then follow, accented by sudden changes of direction. Belugas echolocate throughout this entire sequence of activities to orient themselves and catch their prey (Bel'kovich and Sh'ekotov, 1990).

Belugas in the Beaufort and Chukchi seas appear to eat a variety of fish and invertebrates. A study looking at stable isotope and trace element status of subsistence-hunted beluga whales in both the BS and ECS stocks found the species occupied a higher trophic level than both bowhead and gray whales but did not eat fish exclusively and that both pelagic and benthic foods are important components of their diet (Dehn et al., 2006). Another study using stable isotopes found Arctic cod was a key prey item in the summer diet of beluga whales in the eastern Beaufort (Loseto et al., 2009). Size related dietary differences suggested larger sized beluga preferred offshore Arctic cod, whereas smaller sized beluga appeared to feed on prey in their near shore habitats that included near shore Arctic cod. The presence of Arctic cod groups in shallow near shore and deep offshore habitats may facilitate the behavioral segregation of beluga habitat use as it relates to their size and resource requirements (Loseto et al., 2009). Seaman, Lowry, and Frost (1982) found belugas ate a variety of fish and invertebrates when stomach contents from 119 beluga whales from six locations in the Bering and Chukchi seas were examined. However, 90–100% of stomachs analyzed by Seaman, Lowry, and Frost (1982) contained invertebrates. Huntington et al. (1999) also described the diet of belugas in the nearshore areas of the eastern Bering Sea, Kotzebue Sound, and the eastern Chukchi Sea to include a variety of prey items, but primarily fish. Quakenbush et al. (2015) documented stomach contents obtained from subsistence harvested and stranded belugas in Alaska, between 1954 and 2012. Of these, 62 were from the BS stock collected between 1983 and 2003 at Point Hope and Diomedes and 67 were from the ECS stock collected between 1983 and 2010 near Point Lay and Point Barrow (Quakenbush et al., 2015). Diet of the BS stock includes fish, especially Arctic cod *Boreogadus saida*, and invertebrates, especially shrimp, echiurids, polychaetes, and cephalopods (Quakenbush et al., 2015). Diet of the ECS beluga stock includes fish, especially saffron cod *Eleginus gracilis*, cephalopods, and shrimp and invertebrates, especially shrimp, cephalopods, echiurids, and amphipods (Quakenbush et al., 2015).

Mortality

Killer whales and polar bears are the only known nonhuman predators of beluga whales (Smith, 1985; Sheldon et al., 2003; Loseto et al., 2006; O'Corry-Crowe 2009). Although polar bear predation on beluga whales does not appear to be an important contributor to beluga mortality, polar bears have been observed stalking belugas in shallow waters as well as making successful kills of calves and subadult whales in deeper waters (Smith and Sjare 1990). Killer whale predation of belugas has been observed in Arctic and subarctic waters range wide (as cited in Sheldon et al., 2003), and western Alaska (Lowry, Nelson, and Frost, 1987; Frost, Russell, and Lowry, 1992; George and Suydam, 1998). An increase in the occurrence of killer whales at high latitudes (Clarke et al., 2013), and a longer open water period with less sea ice cover may offer more opportunities for orcas to attack belugas in the future. Some believe orcas avoid sea ice because their large dorsal fin could compromise their ability to surface for air (Matthews et al., 2011). Likewise, some believe belugas are more efficient at moving in ice and can use sea ice as a refuge from killer whale attacks (Ferguson, Kingsley, and Higdon, 2012; Fergusson, Higdon, and Westdal, 2012).

The most recent subsistence harvest numbers for the BS stock by Alaska Native hunters show an annual average take of 65.6 belugas landed during the 5-year period 2008-2012, based on reports from Alaska Beluga Whale Committee representatives and on-site harvest monitoring (Allen and

Angliss, 2015). The most recent subsistence harvest numbers for the BS stock by Canadian Inuvialuit subsistence hunters show an annual average take of 100 belugas landed during the 5-year period, 2005-2009 based on reports from the Fisheries Joint Management Committee and on-site harvest monitoring (Allen and Angliss, 2015). Thus, the mean estimated subsistence take in Canadian (2005-2009) and U.S. (2008-2012) waters from the BS beluga stock is 166 (100 + 65.6) whales.

The most recent subsistence harvest numbers for the ECS stock by Alaska Native hunters show an annual average take of 57.4 belugas landed during the 5-year period 2008-2012 based on reports from Alaska Beluga Whale Committee representatives and on-site harvest monitoring (Allen and Angliss, 2015).

Three different commercial fisheries that could have interacted with beluga whales from the ECS stock were monitored for incidental take by fishery observers during 1990-1997: Bering Sea (and Aleutian Islands) groundfish trawl, longline, and pot fisheries. Observers did not report any mortality or serious injury to beluga whales incidental to these groundfish fisheries (Allen and Angliss, 2015). In the nearshore waters of the southeastern Chukchi Sea, substantial efforts occur in gillnet (mostly set nets) and personal-use fisheries. Although a potential source of mortality, there have been no reported beluga whale takes as a result of these fisheries (Allen and Angliss, 2015). Likewise, there have been no reported beluga whale takes as a result of fisheries in the BS stock (Allen and Angliss, 2015).

Ships strikes, especially from small fast boats, have been identified as a threat to belugas (NMFS, 2008; Carter and Nielsen, 2011). Between 1983 and 2012, a total of 222 beluga carcasses from the St. Lawrence Estuary (Canada) population were examined for causes of death. It was found 4% died as a result of ship/boat strikes (Lair, Martineau, and Measures, 2014). There is limited data in Alaska on mortality of belugas due to boat strikes. Although no mortality due to strikes has been definitely confirmed in Alaska it is suspected; i.e. observations of Cook Inlet beluga whales with propeller scars and Cook Inlet belugas washed ashore dead with wide, blunt marks suggesting a ship strike as the cause of the injury (NMFS, 2008). The rapid reduction in sea ice due to global climate change has precipitated a surge of commercial activities in the Pacific Arctic, including increases in shipping. These increased shipping activities add risk to belugas in the Arctic, via increased likelihood of mortality or injury by ship strikes.

Climate Change

Evidence indicates the Arctic climate is rapidly changing, resulting in reductions in sea (ACIA, 2004; Johannessen et al., 2004). Such changes could affect beluga whales, which may be sensitive to changes in Arctic weather, sea-surface temperatures, or ice extent, and the concomitant effect on prey availability. Laidre et al. (2008) and Heide-Jørgensen (2010) concluded belugas are probably less sensitive to climate change than other Arctic cetaceans after considering their wide distribution and flexible behaviors.

Losses in sea ice could allow marine predators, such as killer whales, to penetrate into the Beaufort Sea for longer distances, increasing the risks of predation on belugas; however, most belugas prefer feeding in deep water near the shelf break, and are capable of diving to 900 m. depths in the Canadian Basin (Hauser et al., 2015; Marin and Smith, 1992) while Miller et al. (2010) recorded the maximum dive depth for a killer whale at 254 m. Hauser et al. (2015) noted Arctic cod, a major prey item for belugas, were most prevalent at the 200-300 m. depth in the Western Beaufort Sea, the depths most belugas dove to. Recent evidence for declining growth, body condition, and blubber thickness suggests that ecosystem changes may be affecting belugas through reduced availability or quality of prey (Harwood et al., 2014, 2015).

Considering the link between sea iced quantity and quality, and Arctic cod whose existence is linked to sea ice, losses in sea ice extent and thickness would likely have adverse effects on beluga body

condition, unless the belugas demonstrate the ability to switch to other prey species. If salmon or whitefish become more prevalent in the Beaufort Sea in the future, some of the effects on Arctic cod could be offset, but to what degree remains speculative at present. Thus future effects of climate changes on beluga whales and their habitat could result in less, or more feeding opportunities, depending upon how the populations of prey species respond to the new environmental conditions. This in turn would affect the physical and behavioral state of belugas, as well as most population parameters.

The spread of disease and parasites has also been suggested as a potential threat to Arctic marine mammals by emigration/immigration events between different marine mammal populations, abetted by sea ice losses, but only in a general context. The true potential for the spread of pathogens between different stocks of beluga whales remains speculative.

Mysticete Whales

The baleen whales (mysticete) likely to occur in the Proposed Action Area are the bowhead whale (*Balaena mysticetus*) and the gray whale (*Eschrichtius robustus*).

Bowhead Whale

Population and status

Bowhead whale stocks occur in Arctic and sub-Arctic waters off eastern and western Canada, western Greenland, offshore waters of Spitsbergen, Alaska, Chukotka, and the Sea of Okhotsk. The International Whaling Commission (IWC) recognizes four stocks of bowhead whale for management purposes (Allen and Angliss, 2015). The Western Arctic stock (also known as the Bering-Chukchi-Beaufort stock) is the largest, and the only stock to inhabit U.S. waters (Allen and Angliss, 2015). It is also the only bowhead stock within the Proposed Action Area.

All stocks of bowhead whales were severely depleted during the intense commercial whaling that started in the early 16th century near Labrador and spread to the Bering Sea in the mid-19th century (Allen and Angliss, 2015). Woodby and Botkin (1993) reported a minimum worldwide population estimate of 50,000 prior to the onset of commercial whaling, with 10,400-23,000 in the Western Arctic stock (dropping to less than 3,000 at the end of commercial whaling). Consequently, the bowhead whale was listed as endangered under the Endangered Species Act (ESA) and as depleted under the MMPA. Despite these designations, the Western Arctic stock of bowheads has been increasing (Allen and Angliss, 2015). Based on concurrent passive acoustic and ice-based visual surveys, George et al. (2004) reported that the Western Arctic stock of bowhead whales increased at a rate of 3.4% from 1978 to 2001, during which time abundance doubled from approximately 5,000 to approximately 10,000 whales. Schweder et al. (2009) estimated the yearly growth rate to be 3.2% between 1984 and 2003 using a sight-resight analysis of aerial photographs. Based on concurrent passive acoustic and ice-based visual surveys, Givens et al. (2013) reported that the Western Arctic stock of bowhead whales has increased at a rate of 3.7% from 1978 to 2011, during which time abundance tripled from approximately 5,000 to approximately 16,000 whales. These whale numbers are also correlated with increases in body condition for whales in the Western Arctic stock (George et al., 2015). It has been hypothesized that sea ice loss has positive effects on secondary trophic production within the bowhead summer feeding areas perhaps increasing the body condition and abundance of the whales (George et al., 2015a).

The minimum population estimate for the Western Arctic stock of bowhead whales is 13,796 based on ice-based counts, acoustic locations, and aerial transect data collected during bowhead whale spring migrations past Point Barrow, AK (Allen and Angliss, 2015) suggesting this stock may be approaching its carrying capacity (Brandon and Wade, 2004; 2006). There is no critical habitat designated for the bowhead whale under its ESA designation.

Distribution

Bowhead whales have a circumpolar distribution in high latitudes in the Northern Hemisphere, and range from 54° to 85° N latitude. The Western Arctic bowhead whale stock generally occurs in seasonally ice-covered waters, generally north of 60° N. and south of 75° N. in the western Arctic Basin (Bering, Chukchi, and Beaufort seas)(Braham, 1984; Moore and Reeves, 1993; Rugh et al., 2003). They live in pack ice and shallow continental shelf waters for most of the year, typically wintering at the southern limit of the pack ice, or in polynyas (large, semi-stable open areas of water within the ice). They spend most of the summer in relatively ice-free waters. While most bowhead whales occur offshore, increasing numbers of animals have been observed in nearshore, shallow areas in the past few years (Clarke et al., 2015a) and their historic distribution patterns may be changing.

There is a general pattern of year-round movements by the Western Arctic bowhead whale population (Figure 3.2.4-7). They have a generalized (with some variability) migration route and feeding and wintering areas. In general, the majority of the Western Arctic stock migrates annually from wintering areas (December to March) in the northern Bering Sea, through the Chukchi in spring (April through May), to the Beaufort Sea where they spend much of the summer (June through September) before returning again to the Bering Sea in fall (October through December) to overwinter (Allen and Angliss, 2015).

During spring migration, bowhead whales typically migrate through spring lead systems along the coast of Alaska, generally in the zone between the shorefast ice and mobile pack ice far offshore to feeding areas in the Beaufort Sea (Quakenbush, Small and Citta, 2013; Allen and Angliss, 2015). The spring migratory corridor between the Bering Strait and Cape Bathurst in the Amundsen Gulf (Canada) has been relatively distinct and consistent over time (Quakenbush, Small and Citta, 2013).

During the summer, bowhead whales feed throughout the Beaufort Sea. Historically they have largely aggregated in the Canadian Beaufort Sea and Barrow Canyon (US) in deep water, where upwellings concentrate prey species, although some whales remain in the eastern Chukchi and western Beaufort seas (Ireland et al., 2009; Clarke et al., 2011a; Quakenbush, Small and Citta, 2013). However, in the last several years there has been a change in areas used by bowheads for feeding to nearshore, shallow regions (Clarke et al., 2015a). This shift may have occurred because of changes in food availability for the whales associated with changes in wind patterns and oceanic upwelling (Citta et al., 2015; Clarke et al., 2015a).

Fall migration takes place in pulses or aggregations of whales out of the Beaufort Sea (Moore and Reeves, 1993). Inupiat whalers report that smaller whales precede large adults and cow-calf pairs on the fall migration (Braham, Krogman, and Carroll, 1984, as reported in Moore and Reeves, 1993). Satellite tagging of bowhead whales between 2006 and 2012 showed that the fall migratory corridor between Hershel Island (Canada) and Point Barrow has been relatively distinct and consistent over time (Quakenbush, Small and Citta, 2013). However, the fall migratory corridor between Point Barrow and the Bering Strait is more variable (Quakenbush, Small and Citta, 2013). This may be related to prey availability, which is also related to the timing of whale movements.

Fall migrating whales typically reach Cross Island in September and October, although some whales might arrive as early as late August. Satellite tracking data (Quakenbush, Small, and Citta, 2010; 2013) for bowhead whales from 2006–2012 and passive acoustic monitoring (Moore, Stafford, and Munger, 2010) indicated most bowhead whales pass Point Barrow in September and October. After passing Point Barrow, the migration paths of individual bowhead whales fan out across the Chukchi Sea with some heading towards Wrangel Island (Russia) and then the coastal waters of Chukotka (Russia) where it is believed they feed; others travel across the Chukchi Sea south of Hanna shoals toward the Russian coast (ADF&G, 2009; Ireland et al., 2009a; Quakenbush, Small and Citta, 2010; 2013; Citta et al., 2012; 2015). After leaving the coastal waters of Chukotka, whales then move south

through the Bering Strait to the Bering Sea to winter (ADF&G, 2009; Ireland et al., 2009a; Quakenbush, Small and Citta, 2010; 2013; Citta et al., 2012).

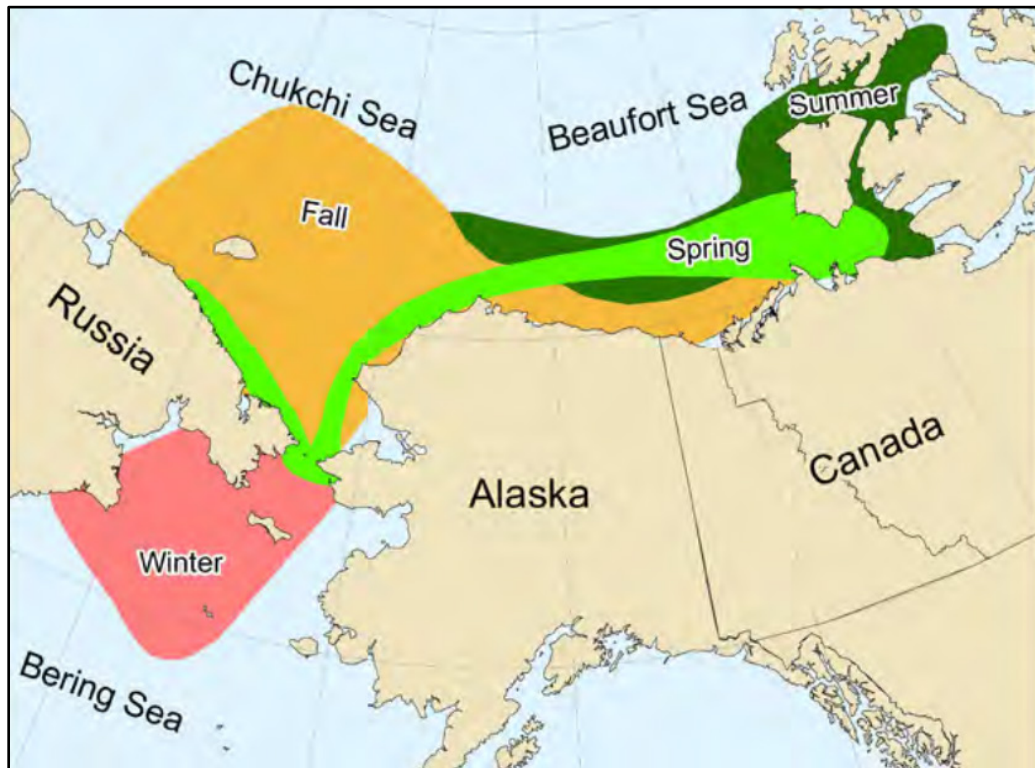

Figure 3.2.4-7. Migration Route; Summer and Wintering areas – Western Arctic Bowhead.
Figure shows the generalized migration route, and summer and wintering areas for the western Arctic bowhead whale. From Quakenbush, Small and Citta (2013).

In 1997 aerial surveys flown by BPXA near the Proposed Action Area showed that the primary fall migration route of bowhead whales was offshore of barrier islands (BPXA, 1998), outside the Proposed Action Area. No bowheads were seen in the Proposed Action Area; however, a few bowheads were observed in lagoon entrances between the barrier islands and in the lagoons immediately inside the barrier islands.

During the 2014 open water season, BPXA conducted a two-dimensional (2D) high-resolution (HR) shallow geohazard survey followed by seabed sonar mapping surveys in the Proposed Action Area. In association with this operation, marine mammal monitoring surveys were conducted. The surveys began on July 16 and were completed by August 30, 2014. During that time, no bowheads were seen in the Proposed Action Area (Smultea et al., 2014). However, bowhead whales were observed during the 2014 ASAMM surveys near the Proposed Action Area seaward of barrier islands on four days during the BPXA surveys: 20 July, 2, 6, and 17 August (Smultea et al., 2014).

BPXA also conducted a marine mammal monitoring survey during their three-dimensional (3D) ocean bottom sensor seismic operations in the North Prudhoe Bay area during the 2014 open-water season (beginning July to mid-September). The survey location was in the U.S. Beaufort Sea approximately 30 miles west of the Proposed Action Area. No bowheads were seen during the survey (Lomac-MacNair et al., 2015). However, bowheads were observed during the 2014 ASAMM surveys in the region further from the BPXA survey area (Clarke et al., 2015a).

In 2015, HAK conducted a marine mammal monitoring survey during their shallow geohazard and strudel scour survey operations in the Proposed Action Area in Foggy Island Bay during the open-water season. Observations for marine mammals were conducted July 9 through July 19, 2015. No

observations of bowhead whales were made in Foggy Island Bay during the survey (Cate et al., 2015).

From 1979-2015 aerial surveys for marine mammals have occurred annually in the summer and fall in the western Beaufort Sea and are currently known as the ASAMM project, which is funded by BOEM and conducted by NOAA. ASAMM surveys found most bowhead whales occur offshore, although some animals have been observed in nearshore areas in the past few years (Clarke et al., 2013; 2014; 2015a). However, few bowheads were observed near the Proposed Action Area during ASAMM surveys since they began (Figure 3.2.4-8).

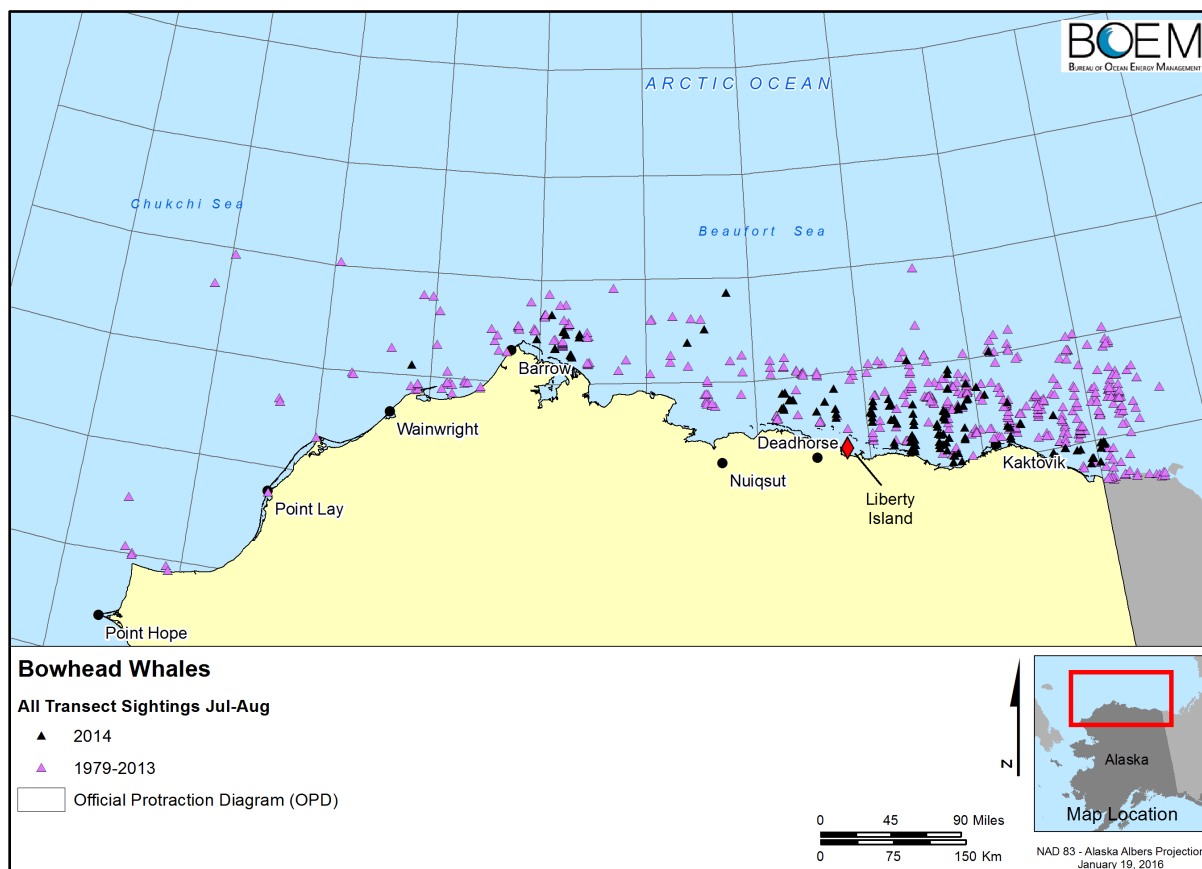

Figure 3.2.4-8. ASAMM Bowhead Sightings, U.S. Arctic, July – August 1979-2014. *Bowheads seen in the U.S Arctic during ASAMM surveys July-August 1979-2014.*

During the ASAMM 2014 surveys, bowhead whales were seen every month flown (July through October) in the western Beaufort Sea (Clarke et al., 2015a). They were seen in two areas in late July: on the outer continental shelf and slope (51-2,000 meters depth) primarily north of Camden Bay, and nearshore east of Point Barrow (Figure 3.2.4-9). Bowhead whales in August were observed across the western Beaufort Sea in both outer and inner shelf waters (Figure 3.2.4-10). Distribution in September was primarily on the inner shelf (<50 m depth) from approximately 140°W to 157°W, with hundreds of whales observed within five kilometers of barrier islands between 146°W and 148.5°W (Figure 3.2.4-10). Bowhead whales were seen in very shallow (≤ 20 m depth) nearshore waters of the Alaskan Beaufort Sea between 143°W and 156°W in August and September, including areas in Camden Bay, between Flaxman Island and Oliktok Point, Alaska, in Harrison Bay, Alaska, and between Cape Halkett and Point Barrow (Figure 3.2.4-10). In September, there was an area of high relative abundance just outside the barrier islands from northeast of Deadhorse to Flaxman Island (Figure 3.2.4-10). Bowhead whales were not seen inside barrier islands (Clarke et al., 2015a; Figure 3.2.4-10). Bowhead whales in October were observed primarily from 146°W to 157°W; a few

hales were seen east of 146°W and several were seen in Barrow Canyon (Figure 3.2.4-10). The closest bowheads came to the Proposed Action Area in 2014 was in the fall: they were seen north of Foggy Island Bay outside of the barrier islands (Figure 3 3.2.4-9).

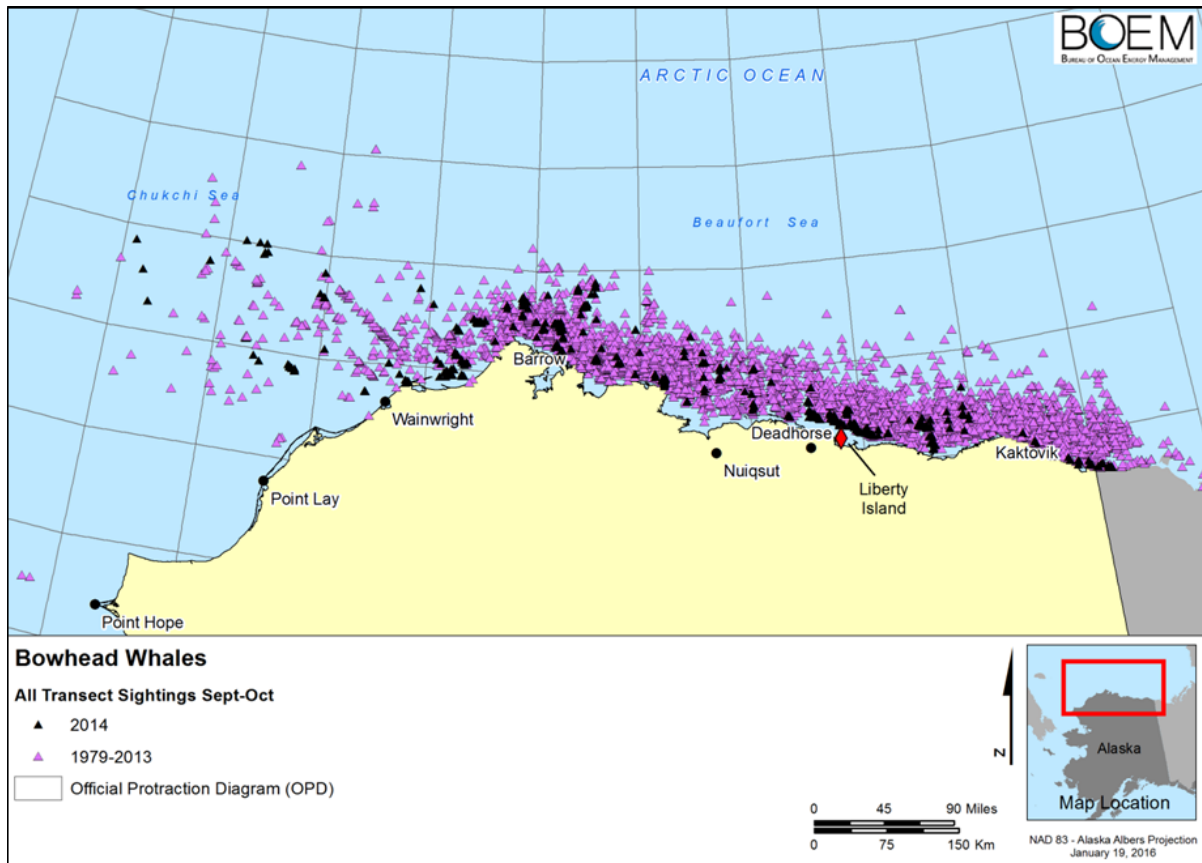

Figure 3.2.4-9. ASAMM Bowhead Sightings, U.S. Arctic, September – October 1979-2014. Bowheads seen in the U.S Arctic during ASAMM surveys September-October 1979-2014.

A study to look at core-use areas used by the Western Arctic bowheads between 2006–2012 using tagged whales identified six core-use areas but did not identify one within or near the Proposed Action Area (Citta et al., 2015). The nearest core-use area was Point Barrow (Citta et al., 2015).

Kuletz et al. (2015) examined seasonal spatial patterns in seabird and marine mammal distribution in the eastern Chukchi and western Beaufort seas to identify biologically important pelagic areas. To identify marine mammal hotspots, data from the ASAMM surveys from mid-June through late October of 2007–2012 were used. They found that the locations of hotspots varied among species but often were located near underwater canyons or over continental shelf features and slopes. Shared hotspots were characterized by strong fronts caused by upwelling and currents, which may have high densities of euphausiids in summer and fall. Bowhead whales were distributed throughout the northeastern Chukchi and western Beaufort seas in both summer and fall but hotspots occurred near Barrow Canyon and along the Beaufort Sea shelf and slope. Relative abundance for bowhead whales was lower and hotspots were distributed farther from shore in summer than in fall. In both seasons, all hotspots were located in the western Beaufort Sea. In summer, hotspots occurred near the mouth of Barrow Canyon, over the outer shelf between Oliktok Point and Prudhoe Bay, and between the 50-m and 200-m isobaths near Demarcation Point. There was one hotspot near shore in Camden Bay, resulting from two sightings of one animal each. In fall, hotspots were grouped over the continental shelf from the mouth of Barrow Canyon to Cape Halkett, north of Oliktok Point, off Point Thomson, and near Demarcation Point. No hotspots were identified in the Proposed Action Area; the closest

was over the outer shelf between Oliktok Point and Prudhoe Bay in the summer and off Point Thomson in the fall.

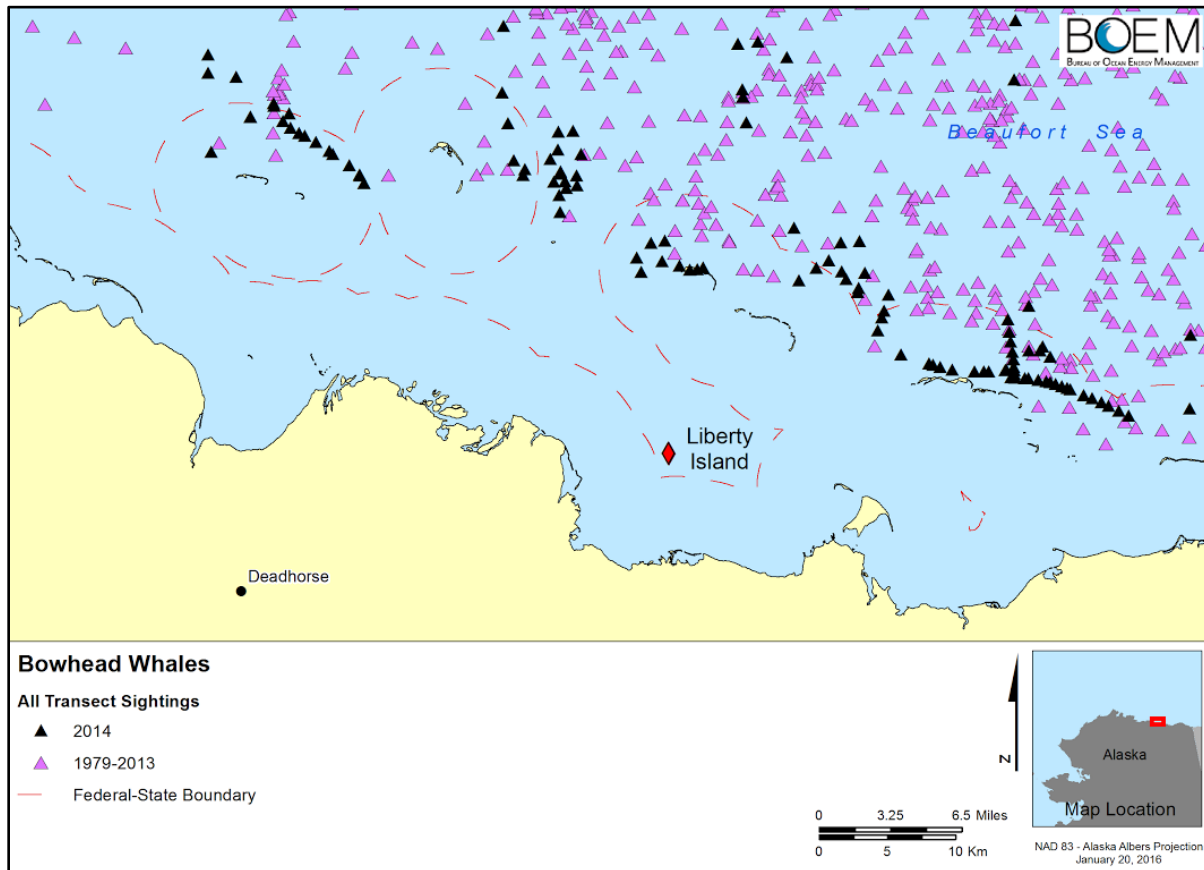

Figure 3.2.4-10. Bowhead Whales Seen Near Liberty during ASAMM Surveys 1979-2014.

Clarke et al. (2015b) evaluated BIAs for bowheads in the U.S. Arctic region and identified nine. The spring (April-May) migratory corridor BIA for bowheads is far offshore of the Proposed Action Area, while the fall (September-October) migratory corridor BIA (western Beaufort on and north of the shelf) for bowheads is further inshore and closer to the Proposed Action Area but is not within it. Clarke et al. (2015b) also identified four BIAs for bowheads that are important for reproduction and encompassed areas where the majority of bowhead whales identified as calves were observed each season; none of these reproductive BIAs were within the Proposed Action Area and only two BIAs came close. Finally, three bowhead feeding BIA were identified. Only the September-October feeding BIA (bowheads feeding on the western Beaufort continental shelf, out to approximately the 50-m isobaths) came close to the Proposed Action Area but did not overlap.

For observations of bowhead whales by Iñupiat whalers near the Proposed Action Area please see Section 3.3.3.

Bowhead whale occurrence in the Proposed Action Area is considered very limited given the barrier islands that separate the Proposed Action from the offshore Beaufort Sea. In addition, the shallow water depths between the barrier islands and the shoreline, especially around the Proposed Action Area, would likely preclude bowhead feeding. From the collective data, few bowhead whales would be expected to be found within the Proposed Action Area.

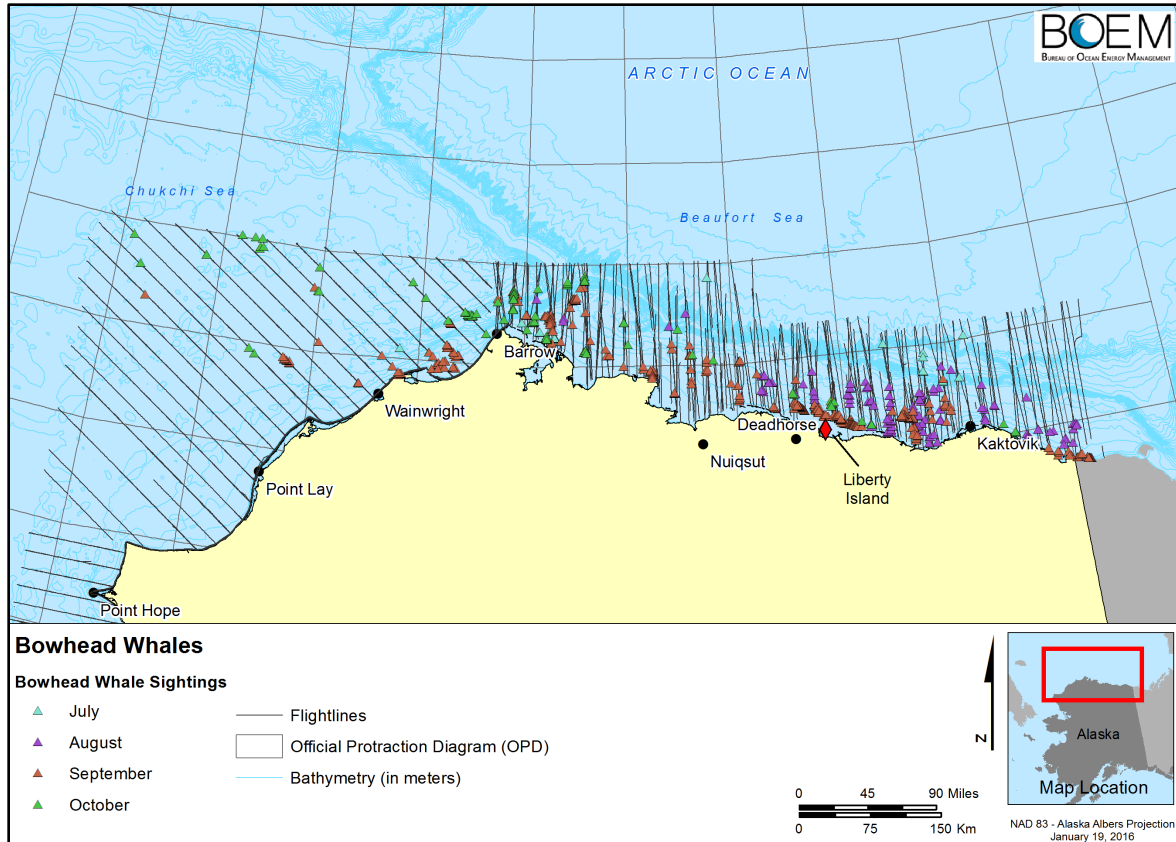

Figure 3.2.4-11. Bowhead whales seen in the U.S Arctic during 2014 ASAMM surveys (plotted by month).

Life History

Bowhead whales are large baleen whales distinguished by a dark body, white chin, and lack of a dorsal fin. Most mating occurs in late winter and spring in the Bering Sea, although some mating occurs as late as September and early October (Koski et al., 1993; Reese et al., 2001). The conception date and length of gestation (13 to 14 months) suggests that calving is likely to occur in mid-May to mid-June, when whales are between the Bering Strait and Point Barrow (BOEM, 2011). The calving interval is about three to four years. Juvenile growth is relatively slow. Bowheads reach sexual maturity at about 15 years of age (12 to 14 m [39 to 46 ft] long) (Nerini et al., 1984). Growth for both sexes slows markedly at about 40 to 50 years of age (George et al., 1999). The lifespan of bowhead whales is thought to exceed 100 years (George et al., 1999; George and Bockstoce, 2008). Given the life history of bowhead whales and gestational constraints on minimum calving intervals (e.g., Reese et al., 2001), and assuming that adult survival rates based on aerial photo-ID data (Zeh et al., 2002; Schweder et al., 2009) and age-at-maturity have remained stable, the trend in abundance implies that the population has been experiencing relatively high annual calf and juvenile survival rates. This is consistent with documented observations of native whalers around St. Lawrence Island, who have reported not only catching more pregnant females but also seeing more young whales than during earlier decades (Noongwook, Huntington, and George, 2007). Although the sample size of harvested mature females was small for 2014, the pregnancy rate was consistent with the long-term average of about 33% (George et al., 2004; George et al., 2011; Suydam et al., 2015).

Bowhead diving behavior is situational (Stewart, 2002). Calves dive for very short periods and their mothers tend to dive less frequently and for shorter durations. Feeding dives tend to last from three to 12 minutes and may extend to the relatively shallow bottom in the Beaufort Sea. “Sounding” dives average between seven and 14 minutes.

The bowhead whale usually travels alone or in groups of three to four individuals. However, in 2009, researchers observed 297 individual bowheads aggregated near Point Barrow and a group of 180 bowhead whales were also seen feeding and milling (Clarke et al., 2011b).

The large whales such as bowheads generally produce low-frequency sounds in the tens of Hz to the several kHz band, with a few signals extending above 10 kHz (Southall et al., 2007). Bowhead whales are among the more vocal of the baleen whales (Clark and Johnson, 1984). These sounds appear to serve predominantly social functions (Wursig and Clark, 1993), including reproduction and maintaining contact with offspring (Wursig et al., 1989), but they may also play some role in spatial orientation (Southall et al., 2007). Bowhead whales in western Greenland waters produced songs of an average source level of 185 ± 2 dB rms re 1 mPa @ 1 m centered at a frequency of 444 ± 48 Hz (Roulin et al., 2012). Given background noise, this allows bowhead whales an active space of 40-130 kilometers (Roulin et al., 2012).

Most bowhead sounds are distinctly different from sounds produced by other marine mammals endemic to the sub-Arctic and Arctic habitats. As a result, monitoring for the occurrence of bowhead sounds is a very effective mechanism for detecting their presence throughout the year (Clark et al., 2015). Bowheads mainly communicate with low frequency sounds. Most underwater calls are at a fairly low frequency and easily audible to the human ear. Vocalization is made up of moans of varying pitch, intensity and duration, and occasionally higher-frequency screeches. Bowhead calls have been distinguished by Würsig and Clark (1993): pulsed tonal calls, pulsive calls, high frequency calls, low-frequency FM calls (upsweeps, inflected, downsweeps, and constant frequency calls). However, no direct link between specific bowhead activities and call types was found. Bowhead whales have been noted to produce a series of repeating units of sounds up to 5000 Hz that are classified as songs, produced primarily by males on the breeding grounds (Delarue, 2011). It appears that bowhead whale singing behavior differs from that of other mysticetes in that multiple songs are sung each year (Johnson et al., 2014).

Bowhead whales have well-developed capabilities for navigation and survival in sea ice. Bowhead whales are thought to use the reverberations of their calls off the undersides of ice floes to help them orient and navigate (Ellison, Clark, and Bishop, 1987; George et al., 1989). This species is well adapted to ice-covered waters and can easily move through extensive areas of nearly solid sea ice cover (Citta et al., 2012). Their skull morphology allows them to break through ice up to 18 cm thick to breathe in ice covered waters (George et al., 1989).

Bowhead whales are grouped among low frequency functional hearing baleen whales (Finneran and Jenkins, 2012; Ciminello et al., 2012; Southall et al., 2007). Inferring from their vocalizations, bowhead whales should be most sensitive to frequencies between 20 Hz-5 kHz, with maximum sensitivity between 100-500 Hz (Erbe, 2002). Bowhead whale songs have a bandwidth of 20 to 5000 Hz with the dominant frequency at approximately 500 Hz and duration lasting from 1 minute to hours. Pulsive vocalizations range between 25 and 3500 Hz and last 0.3 to 7.2 seconds (Clark and Johnson, 1984; Wursig and Clark, 1993; Erbe, 2002). While there is no direct data on hearing in low-frequency cetaceans, the functional hearing range is anticipated to be between 5 Hz to 30 kHz (Watkins, 1986; Au et al., 2006; Southall et al., 2007; Ciminello et al., 2012; Finneran and Jenkins, 2012).

Bowhead whales appear to have good lateral vision. Recognizing this, whalers approach bowheads from the front or from behind, rather than from the side (Rexford, 1997; Noongwook et al., 2007). In addition, whalers wear white parkas on the ice so that they are not visible to the whales when they surface (Rexford, 1997).

Olfaction may also be important to bowhead whales. Recent research on the olfactory bulb and olfactory receptor genes suggest bowheads not only have a sense of smell, but that it is better

developed than in humans (Thewissen et al., 2011). The authors suggest that bowheads may use their sense of smell to find dense aggregations of krill upon which to prey.

Diet and feeding

Bowheads are filter feeders, filtering prey from the water through baleen (Lowry, 1993). They feed throughout the water column, including bottom feeding as well as surface skim feeding (Würsig et al., 1989). Skim feeding can occur when animals are alone or may occur in coordinated echelons of over a dozen animals (Würsig et al., 1989). Bowhead whales typically spend a high proportion of time on or near the ocean floor. Even when traveling, bowhead whales visit the bottom on a regular basis (Quakenbush et al., 2010). Laidre, Heide-Jorgensen, and Nielsen (2007) and others have identified krill concentrated near the sea bottom and bowhead whales have been observed with mud on heads and bodies and streaming from mouths (Mocklin, 2009).

The most common prey species found in the stomachs of harvested bowheads are small shrimp-like crustaceans such as euphausiids, copepods, mysids, and amphipods (Moore, Stafford, and Munger, 2010; Lowry, Sheffield, and, George, 2004). Euphausiids and copepods are thought to be their primary prey since other crustaceans (isopods [a group of crustaceans that includes woodlice, sea slaters and their relatives] and decapods [a group of crustaceans that includes crayfish, crabs, lobsters, prawns and shrimp]), and fish constitute minor fractions of their stomach contents. Carbon-isotope analysis of bowhead baleen indicates a significant amount of feeding occurs in wintering areas (Schell, Saupe, and Haubenstein, 1987). The stomach contents of one bowhead harvested in the northern Bering Sea indicated that the whale had fed entirely on benthic organisms, predominantly gammarid amphipods and cumaceans (not copepods, euphausiids, or other planktonic organisms) (Hazard and Lowry, 1984).

Concentrations of zooplankton appear necessary for bowhead whales and other baleen whales to feed efficiently to meet energy requirements (Kenney et al., 1986; Lowry, 1993). It is estimated that a 60 ton bowhead whale eats 1.5 t of krill each day. Estimated rate of consumption is 50,000 individual copepods, each weighing about 0.004 g, per minute of feeding time (BOEM, 2011). George et al. (2015a) found that there has been an overall increase in Western Arctic bowhead whale body condition over the last 25 years. The significant long-term increase in body condition is correlated with reductions in sea ice and other environmental factors, which may be associated with higher production in the Pacific-Arctic marine ecosystem favoring increases in water-column invertebrates (George et al., 2015a). The abundance of Western Arctic bowheads has also increased markedly over the last 25 years suggesting bowheads may be one of the ‘winners’, at least short-term, in climate change processes because of their feeding habits.

Western Arctic bowhead whales feed in the Chukchi and Beaufort Seas but this varies in degree among years, individuals, and areas (see Clark et al 2011a, b, 2012, 2013, 2014, and 2015). It is likely that bowheads feed opportunistically where oceanographic conditions produce locally abundant food (Carroll et al., 1987). Based on decades of ASAMM survey data, other aerial surveys, ice-based observations, passive acoustic monitoring, and satellite telemetry, Clarke et al. (2015b) identified three bowhead feeding BIAs in the U.S. Arctic region: (a) Barrow Canyon in May; (b) Smith Bay to Point Barrow, generally shoreward of the 20-m isobaths, from August to October; and (c) the western Beaufort continental shelf, out to approximately the 50-m isobaths, in September to October.

None of the bowhead feeding BIAs are in the Proposed Action Area and there are no known concentrations or notable feeding areas for bowhead whales in the Proposed Action Area.

Historically, the nearest feeding areas of particular consequence are in the vicinity of Barrow Canyon (Sheldon and Mocklin, 2013) and a small feeding area slightly north of Bodfish Island (Clarke et al., 2012, 2013). However, in the last several years there has been a change in areas used by bowheads for feeding (Clarke et al., 2015a). In 2014, bowhead whales were observed feeding and milling during summer months in the western Beaufort Sea primarily at water depths ≤ 50 m, although some feeding

whales were recorded in deeper water (100-500 m) (Clarke et al., 2015a). Some of these shallow areas, including in Camden Bay and nearshore between Prudhoe Bay and Flaxman Island, are not areas where feeding bowhead whales have commonly been seen in past years (Clarke et al., 2015a). Most (82%) of the feeding whales in these areas were within the 20 m isobath; 52% were at ≤ 10 m depth (Clarke et al., 2015a). This shift may have occurred because of changes in food availability for the whales associated with changes in wind patterns and oceanic upwelling (Citta et al., 2015; Clarke et al., 2015a). This trend toward shallow, nearshore feeding by bowhead whales may, at some point in the future, overlap with the Proposed Action Area.

Mortality

Little is known about the natural mortality of bowhead whales (Philo, Shotts, and George, 1993). From 1964 through the early 1990s, at least 36 deaths were reported in Alaska, Norway, Yukon and Northwest Territories for which the cause could not be established (Philo et al., 1993). Bowhead whales have no known predators except perhaps killer whales. The frequency of attacks by killer whales upon the Western Arctic stock of bowhead whales is assumed to be low but may be increasing (George et al., 1994; George et al., 2015b). Of 195 whales examined from the Alaskan subsistence harvest from 1976-1992, only 8 (4.1%) had been wounded by killer whales. Also, hunters on St. Lawrence Island found two small bowhead whales (< 9 m) dead as a result of killer whale attacks (George et al., 1994). A more recent study of bowhead found that of 378 bowheads harvested by Alaska Native Peoples between 1990 and 2012, 30 whales (7.9%) had scarring “rake marks” consistent with killer whale injuries and another 10 had possible injuries. Plus, in 2013 a stranded bowhead was confirmed killed by an orca 30 miles south of Point Barrow and another stranded bowhead was suspected killed by an orca in the Fall of 2015 (North Slope Borough, 2015). Most bowheads over 17m show evidence of killer whale predation attempts, particularly in the decade since 2002. Only 1-2% of small bowheads (< 10 m) showed such injuries probably because most young animals have less ‘exposure’ time to killer whales compared to adults plus calves that are attacked are more likely to be killed.

George et al. (2015b) found killer whale attacks on bowheads in Alaska were statistically more frequent from 2002-2012. This increase is also consistent with findings on Eastern Canada-Western Greenland bowheads by Reinhart et al. (2013) indicating a dramatic increase in rake marks on bowhead from 1986 to 2012 where 10.2% of bowhead whales bore rake marks from killer whales. Reasons for this increase might include: better reporting and/or sampling bias, increase in killer whale population size, an increase in occurrence of killer whales at high latitudes (Clarke et al., 2013), and a longer open water period offering more opportunities to attack bowheads (George et al., 2015b).

Bowhead whales have been targeted by subsistence whaling for at least 2,000 years (Stoker and Krupnik, 1993). Subsistence harvest is regulated by quotas set by the International Whaling Commission (IWC) and allocated by the Alaska Eskimo Whaling Commission. Bowhead whales are harvested by Alaska Native Peoples in the Beaufort, Bering, and Chukchi Seas. Alaska Native subsistence hunters take approximately 0.1-0.5% of the population per annum, primarily from 11 Alaska communities (Philo, Shotts, and George, 1993; Suydam et al., 2011).

Inuit peoples in Canada and Russia are also known to take whales from this stock. Hunters from the western Canadian Arctic community of Aklavik harvested one whale in 1991 and one in 1996. Twelve whales were harvested by Russian subsistence hunters between 1999-2005 (Allen et al., 2014). No catches for Western Arctic bowheads were reported by either Canadian or Russian hunters for 2006-2007 or by Russia in 2009, but two bowheads were taken in Russia in 2008, and in 2010 (IWC, 2012; Allen et al., 2014). In 2014, 38 bowheads were landed by Alaska Native Peoples, which is similar to the average (41.6) for the previous 10 years (2004-2013) (Suydam et al., 2015).

Some additional mortality may be due to human-induced injuries, including embedded shrapnel and harpoon heads from hunting attempts, rope and net entanglement in harpoon lines, and entanglement

in commercial fishing gear (Philo, Shotts, and George, 1993; George et al., 2015). Several cases of rope or net entanglement have been reported from whales taken in the subsistence hunt (Philo, Shotts, and George, 1993). There are no observer program records of bowhead whale mortality incidental to commercial fisheries in Alaska. However, some bowhead whales have historically had interactions with crab pot gear. From 1993-2012, there have been at least 14 reports of bowheads actively entangled with manmade line and/or commercial fishing gear attached; seven were stranded dead, four were seen swimming, and three were harvested for subsistence (George et al., 2015b; Sheffield et al., 2016). At least four of these entanglement events were confirmed as commercial pot gear. NMFS Alaska Region stranding reports also document three bowhead whale entanglements between 2001 and 2005. In 2003, a bowhead whale was found dead in Bristol Bay entangled in line around the peduncle and both flippers; the origin of the line is unknown. In 2004, a bowhead whale near Point Barrow was observed with fishing net and line around the head. A dead bowhead whale found floating in Kotzebue Sound in July 2010 was entangled in crab pot gear similar to that used in the Bering Sea crab fishery (Allen and Angliss, 2015). During the 2011 spring aerial survey of bowhead near Point Barrow, one entangled bowhead was photographed (Mocklin et al., 2012).

George et al. (2015b) found 12% of bowheads harvested between 1990-2012 showed entanglement scars from fishing gear. The frequency of entanglement scars was highly correlated with body length—about 50% of large bowheads (>17 m) exhibit gear scars while whales < 9 m rarely showed such scars. In the George et al., (2015b) study, male bowhead whales had significantly higher rates of line entanglement scars than females. That higher entanglement scar rate may be due to their observed greater longevity and therefore prolonged exposure to entanglement risk. It is thought most of these entanglement scars are from fishing/crab gear, probably from the Bering Sea.

Bowhead whales are among the slowest moving of whales, which may make them particularly susceptible to ship strikes, although records of strikes on bowhead whales are rare (Laist et al., 2001; George et al., 2015b). About 2% of the bowhead whales taken by Alaskan Natives bore scars from ship strikes (George et al., 2015b). Few whales showing scars from ship strikes may be due to relatively low levels of commercial ship traffic in the Pacific Arctic, and/or these types of injuries may result in higher mortality. Until recently, few large ships have passed through most of the bowhead whale's range, but this situation may be changing as northern sea routes become more navigable with the decline in sea ice. This increase in vessel presence could result in an increased number of vessel collisions with bowhead whales.

Climate Change

Climate change is a major concern for bowhead whales, as it is for other Arctic marine mammals. Climate projections show a pronounced warming over the Arctic, with accelerated sea ice losses as described in 3.1.7. with some of the greatest changes occurring in the Beaufort Sea. Laidre et al. (2008) concluded bowhead whales are moderately sensitive to climate, while George et al. (2006) found bowhead body condition was better in years having light sea ice cover. Collectively this information, along with the growing bowhead population, and good calf production, suggests a resilience or possible affinity to longer open water seasons with less sea ice.

If ocean acidification and sea ice losses shift the Beaufort Sea to more of a pelagic system, there may be an increase in fishes or other prey species in the water column where bowheads mostly feed. Such conditions could favor bowhead feeding, and overall health; however, longer periods of time with less sea ice might eventually open the Beaufort Sea to incursions by killer whales which could prey on bowheads. Considering the numbers of killer whales observed in the Chukchi Sea to date, most likely the killer whale predation would not have a profound numerical impact on bowhead whales as long as the population size of the stock remains high.

Another potential benefit of decreasing sea ice cover in the Beaufort Sea could include emigration of individual whales from the bowhead population in the Beaufort Sea to populations in the Atlantic,

which are much smaller. Such events could add needed genetic diversity to other bowhead whale stocks without risk to the Western Arctic stock of bowhead whales.

The spread of disease and parasites has also been suggested as a potential threat to Arctic marine mammals by such emigration/immigration events, abetted by sea ice losses, but only in a general context. The true potential for the spread of pathogens between different stocks of bowhead whales remains speculative.

Gray Whale

Population and status

There are currently two formally recognized North Pacific populations of gray whales: the Western Pacific subpopulation (also known as the Western North Pacific [WNP] or the Korean-Okhotsk population) that is critically endangered according to the IUCN Red Book but shows signs of slow recovery, and the Eastern Pacific population (also known as the Eastern North Pacific [ENP] or the California-Chukchi population) has recovered from exploitation (whaling) after >70 years of protection and was removed from listing under the ESA in 1994 (Swartz, Taylor, and Rugh, 2006). Gray whales from the ENP are the only ones that may be seen in the Proposed Action Area (Carretta et al., 2015).

Recent abundance estimates for the ENP gray whale population have ranged between 17,000 and 20,000 (Swartz, Taylor, and Rugh, 2006; Rugh et al., 2008; Punt and Wade, 2012). For stock assessment purposes, NMFS currently uses a minimum population estimate of 20,125 animals (Carretta et al., 2015). In 1999–2000, an unusually large number of gray whales stranded along the coast from Mexico to Alaska (Gulland et al., 2005), and many scientists thought the population had reached carrying capacity. In spite of this, the ENP population appears to be generally increasing, and Carretta et al. (2014) reported that the ENP gray whale population has now recovered to levels seen prior to the Unusual Mortality Event (UME) of 1999–2000.

Distribution

Most of the ENP stock of gray whales spends its summer feeding in the northwestern Bering Sea, and in the Chukchi Seas (Rice and Wolman, 1971; Berzin, 1984; Nerini, 1984), migrating to winter and calve in the waters of Baja California. Gray whales prefer areas with little or no ice cover and spend most of their time in water less than 200 ft. (60 m) deep (Moore and DeMaster, 1997).

The ENP stock migrates along the U.S. west coast on both their northward and southward migration. This species makes the longest annual migration of any mammal; 9,321–12,427 miles (15,000–20,000 km) roundtrip (Jefferson, Webber, and Pitman, 2008; Jones and Swartz, 2009). The migration connects summer Arctic and north Pacific feeding grounds with winter mating and calving regions in temperate and subtropical coastal waters. Winter grounds extend from central California south along Baja California, the Gulf of California, and the mainland coast of Mexico.

Gray whale migration along the U.S. west coast can be loosely categorized into three phases (Rugh, Sheldon, and Schulman-Janiger, 2001; 2008). Beginning in the fall, whales start the southward migration from summer feeding areas to winter calving areas. The southbound phase includes all age classes as they migrate primarily to the nearshore waters and lagoons of Baja, Mexico, mainly following the coast, and occurs from October through March. The southbound trip averages two months in length. The northward migration to the feeding grounds occurs in two phases. The first phase consists mainly of adults and juveniles that lead the beginning of the northbound migration from late January through July, peaking in April through July. Newly pregnant females go first to maximize feeding time, followed by adult females and males, then juveniles (Jones and Swartz, 2009). The second phase consists primarily of cow-calf pairs which begin their northward migration later (February to July) remaining on the breeding grounds longer to allow calves to strengthen and

rapidly increase in size before the northward migration (Jones and Swartz, 2009; Herzing and Mate, 1984).

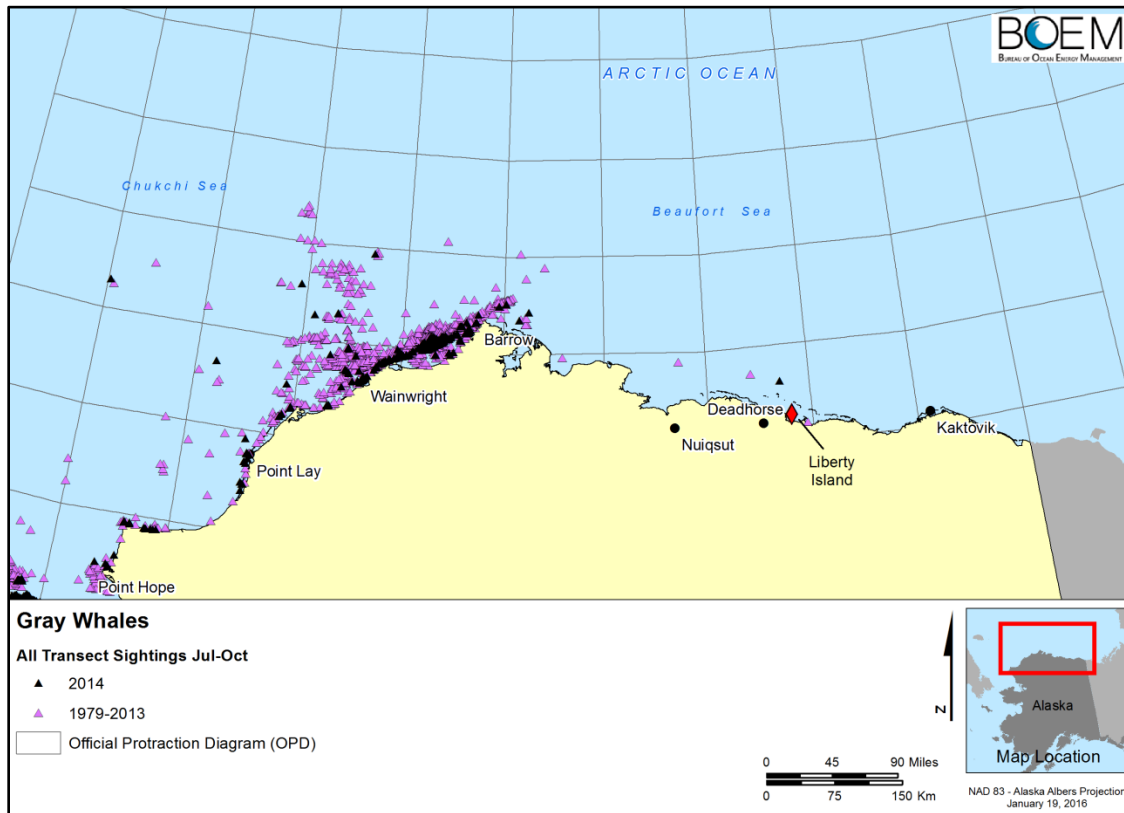

Figure 3.2.4-12. Gray whales seen in the U.S. Arctic during ASAMM surveys 1979-2014.

Gray whales are generalist feeders mostly foraging on benthic prey in shallow continental shelf waters. The narrow continental shelf in the Beaufort Sea provides suboptimal feeding habitat for large numbers of gray whales, hence their presence in the Beaufort is very low east of Barrow Canyon; they rarely venture past 155.8°W (Clarke et al., 2015a).

During marine mammal monitoring associated with exploration activities around the Hammerhead and Torpedo ARCO drilling sites, Hall et al. (1994) found several gray whales north west of Camden Bay about 13 - 25 miles (21 – 40 km) from the coast.

During the 2014 open water season, BPXA conducted a two-dimensional (2D) high-resolution (HR) shallow geohazard survey followed by seabed sonar mapping survey in the Proposed Action Area. In association with this operation, marine mammal monitoring surveys were conducted. The surveys began on 16 July and were completed by 30 August 2014. No grey whales were seen in the survey area (Smultea et al., 2014).

BPXA also conducted a marine mammal monitoring survey during their three-dimensional (3D) ocean bottom sensor seismic operations in the North Prudhoe Bay area during the 2014 open-water season (beginning July to mid-September). The survey location was in the U.S Beaufort Sea approximately 30 miles (48 km) west of the Proposed Action Area. No grey whales were seen during the survey (Lomac-MacNair et al., 2015).

In 2015, HAK conducted a marine mammal monitoring survey during their shallow geohazard and strudel scour survey operations in the Proposed Action Area in Foggy Island Bay during the open-water season. Observations for marine mammals were conducted July 9 through July 19, 2015. No observations of gray whales were made in Foggy Island Bay during the survey (Cate et al., 2015).

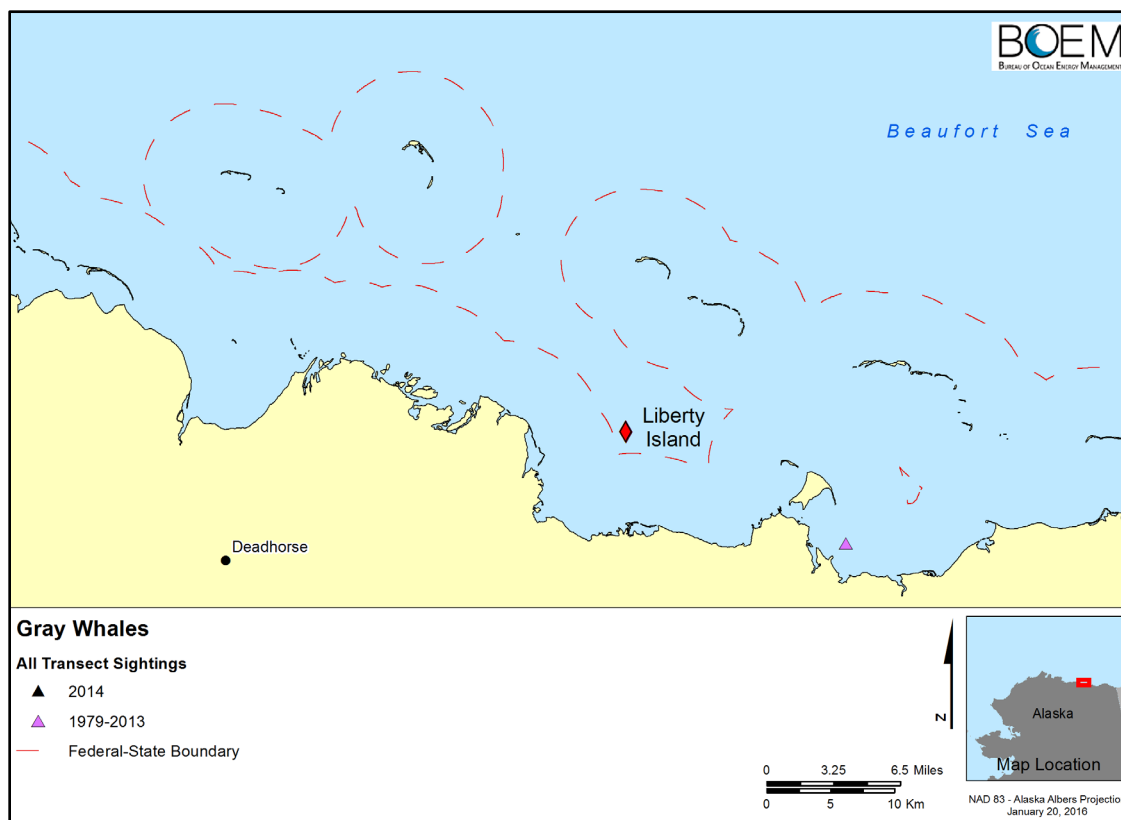

Figure 3.2.4-13. Gray Whales Seen near Liberty during ASAMM Surveys 1979-2014.

Aerial surveys for marine mammals have occurred annually in the summer and fall in the western Beaufort Sea from 1979-2015; these are currently known as the ASAMM project, which is funded by BOEM and conducted by NOAA. ASAMM surveys have documented that gray whale distribution commonly extends eastward to 155.8°W. Few whales have been sighted by ASAMM in the Beaufort Sea (Figure 3.2.4-12). The easternmost live gray whale sighting by ASAMM occurred in 2014 (Figure 3.2.4-12 and 3.2.4-13); it was observed swimming nearshore, immediately north of Cross Island (147.9°W; over 20 miles northwest of Foggy Island Bay and the Proposed Action Area, about 300 kilometers east of their normal range (Clarke et al., 2015a). The remaining gray whale sightings in the Beaufort Sea have occurred since 1997 and total 20 whales (Clarke et al., 2015a). Those sightings occurred offshore in Barrow Canyon, north of Dease Inlet, at the mouth of Smith Bay, north of Harrison Bay, and north of Gwydyr Bay. Most Beaufort gray whales were swimming, resting, diving, or milling, although five gray whales were feeding (Clarke et al., 2015a). None were seen alive in the Proposed Action Area although a dead gray whale was located in 1988 just to the south of Tigvariak Island.

Outside of ASAMM and industry surveys there have been a few sightings of gray whales in the Beaufort Sea and none in the Proposed Action Area. One gray whale was taken by hunters at Cross Island in 1933 (Maher, 1960). One gray whale was sighted just west of Barter Island in the fall of 1997 (Marquette and Braham, 1980). Six gray whales have been sighted in the Canadian Beaufort Sea; three in 1980 during extensive aerial surveys for bowheads whales (Rugh and Fraker, 1981) and three in 2014 during a research cruise (Clarke et al., 2015a). One female gray was tagged with a tracking device near Atkinson Point in September 2009; this whale traveled west across the Beaufort Sea (Quakenbush, Small and Citta, 2013).

Kuletz et al. (2015) examined seasonal spatial patterns in seabird and marine mammal distribution in the eastern Chukchi and western Beaufort seas to identify biologically important pelagic areas. To

identify marine mammal hotspots, data from the ASAMM surveys from mid-June through late October of 2007–2012 were used. They found that the locations of hotspots varied among species but often were located near underwater canyons or over continental shelf features and slopes. Shared hotspots were characterized by strong fronts caused by upwelling and currents, which may have high densities of euphausiids in summer and fall. Gray whales were distributed throughout the northeastern Chukchi Sea and into the western Beaufort Sea only as far east as Dease Inlet. In both summer and fall, high relative abundance and hotspots occurred in the nearshore zone from near Wainwright to the mouth of Barrow Canyon. In fall, additional hotspots occurred in Hope Basin. No hotspots were identified close to or in the Proposed Action Area.

Clarke et al. (2015b) evaluated BIAs for gray whales in the U.S. Arctic region and identified two; one for feeding and one for reproduction both in the Chukchi Sea. No BIAs were identified for gray whales in the Beaufort Sea; therefore none are close to the Proposed Action Area.

The occurrence of gray whales in the Beaufort Sea is not new and does not seem to be a range expansion; however, because gray whales are opportunistic feeders, their distribution and density in the Beaufort Sea may change in the future if foraging habits shift. To date, there have been no sightings of gray whales in the Proposed Action Area. From the collective data documenting only a handful of gray whales in the Beaufort Sea and the shallow water depths and substrate (i.e. Boulder Patch) of the Proposed Action Area, it is unlikely gray whales would be found within the Proposed Action Area.

Life History

Gray whales can grow to about 50 feet (15 m) long, and weigh approximately 80,000 pounds (35,000 kg). Females are slightly larger than males. The average and maximum life span of gray whales is unknown, although one female was estimated at 75-80 years old after death (Jones and Swartz, 2002). Gray whales become sexually mature between six and 12 years, at an average of eight years old. Female gray whales usually give birth every two to three years. Females give birth to a single calf after 12-13 months of gestation. Newborn calves are approximately 14-16 feet (4.5-5 m) long, and weigh about 2,000 pounds (920 kg). Calves are weaned at about eight months, after they have journeyed with their mothers back to the northern feeding grounds. Calves are born dark gray and lighten as they age to brownish-gray or light gray.

Gray whales are frequently observed traveling alone or in small, unstable groups, although large aggregations may be seen on feeding and breeding grounds. Similar to other baleen whales, long-term bonds between individuals are rare. Feeding gray whales are usually alone or in small groups but normally in near proximity to relatively high numbers (10s to 100s) of foraging conspecifics. Feeding behavior is often characterized by predictable surface-dive-respiration patterns.

The large whales, such as grays, generally produce low-frequency sounds in the tens of Hz to the several kHz band, with a few signals extending above 10kHz (Southall et al., 2007). These sounds appear to serve predominantly social functions, including reproduction and maintaining contact, but they may also play some role in spatial orientation (Southall et al., 2007) and a boxcar frequency range of 5 Hz to 30kHz (Finneran and Jenkins, 2012, Ciminello et al., 2012). Gray whales are not typically known for making a wide range of sounds, but they do make some fairly simple vocalizations. Their calls are described as knocks, grunts, and pulses (Fish, Sumich, and Lingle, 1974; Edds-Walton, 1997). As many as seven different kinds of sounds are produced by gray whales, ranging from less than 100 Hz to more than 3000 Hz. However, most of them are concentrated between about 300 and 900 Hz (Fish, Sumich, and Lingle, 1974; Edds-Walton, 1997). The hollow-sounding knocking sounds, most commonly recorded on summer feeding grounds, are relatively quiet compared with some of the sounds produced by other baleen whales. Pulses may be repeated in series of 2-30 and are more common during the winter when the whales are breeding and most vocal.

Individual gray whales may be able to communicate with one another with their low frequency calls over distances of a mile or more.

Gray whales are grouped in the low-frequency cetacean hearing group with an estimated auditory bandwidth of between 7 Hz to 22 kHz (Southall et al., 2007) and a boxcar frequency range of 5 Hz to 30kHz (Finneran and Jenkins, 2012, Ciminello et al., 2012). There is contrasting data on what frequencies gray whales are most sensitive to. Gray whale hearing may be better at 3kHz, 6kHz, and 9kHz than at lower frequencies (Ridgeway and Carder, 2001). However, behavioral data for free-ranging gray whales in breeding lagoons suggests they are most sensitive to tones between 800 Hz and 1500 Hz (Dahlheim and Ljungblad, 1990).

The visual acuity of the gray whale is a little worse than, but comparable to, that in some other cetaceans like minke whale and common bottlenose dolphin, and close to that in harbor porpoise (Mass and Supin, 1997). This suggests that visual abilities of the gray whale are comparable with those of dolphins which actively use their vision and demonstrate fine image recognition (Mass and Supin, 1997).

Diet and feeding

Gray whales are opportunist and generalist feeders (Dunham and Duffus, 2001; Feyrer and Duffus, 2011) that are primarily restricted to shallow continental shelf waters for bottom foraging. Their primary prey include swarming mysids, tube-dwelling amphipods, and polychaete worms in the Bering and Chukchi seas, but they also consume red crabs, baitfish, and other food (crab and fish larvae, amphipods, fish eggs, cephalopods, megalops, etc.) (Reilly et al., 2008). Nelson et al. (1993) noted that in the Chukchi Sea, within areas where gray whales were observed feeding off Wainwright, amphipod species observed included *Ampelisca macrocephala*, *A. estrichti*, *Byblis gaimardi*, *Atylus bruggeni*, *Ischyrocerus*, *Protomedeia* spp., *Grandifoxus*, and *Erichthonius*, with amphipods comprising 24% of the biomass (Feder et al., 1989).

Gray whales tend to use recurring feeding areas in Alaska. Primary feeding areas include the eastern Chukchi, some shoal areas, and the western Chukchi from Wrangel Island to the Bering Strait, but they may be found throughout the Chukchi Sea in shallow waters over the continental shelf. Stoker (1990) studied one of the gray whale high-use areas—the central Chirikov Basin between St. Lawrence Island and the Bering Strait—and found gray whales disturb at least 6% of the benthos each summer while consuming >10% of the yearly amphipod production. Gray whale feeding areas offshore of northern Alaska are characterized by low species diversity, high biomass, and the highest secondary production rates reported for any extensive benthic community (Rugh et al., 1999). According to Highsmith and Coyle (1992), gray whales rely on rich benthic amphipod populations in the Bering and Chukchi Seas to renew fat resources needed to sustain them during their winter migration to and from Baja California.

ASAMM aerial surveys conducted annually during open-water season in the Beaufort Sea and Chukchi Seas have documented a gray whale foraging hotspot in the northeastern Chukchi Sea that typically extends from Icy Cape to Point Barrow shoreward of Barrow Canyon on the continental shelf (Clarke et al., 2015a). However, since gray whales are rarely seen in the Beaufort Sea, no feeding areas have been identified there.

At this time, the narrow continental shelf in the Beaufort Sea provides suboptimal feeding habitat for large numbers of gray whales, hence their presence there is very limited east of Barrow Canyon (Clarke et al., 2015a). However, benthic-dominated ecosystems of the Bering and Chukchi Seas may become pelagic-dominated as global climate change continues and multi-year sea ice continues to melt (Grebmeier et al., 2006). As these changes occur, gray whales, with their flexible foraging strategy, may shift their foraging habits and habitats to continue to target the most abundant and dense

food sources as they did during the Pleistocene (Pyenson and Lindberg, 2011). It is possible more gray whales would travel to the Beaufort Sea to take advantage of new prey resources in the future.

Mortality

Predation by killer whales on gray whales has been recognized for some time: for example, Rice and Wolman (1971) noted that 18% of gray whales examined at a California whaling station showed evidence of being attacked by killer whales. Jefferson, Stacey, and Baird (1991) and Ford and Reeves (2008) summarized numerous accounts of gray whales being attacked and sometimes killed by killer whales. Most of these attacks occurred on the northbound gray whale migration and were concentrated in California near Monterey Bay and on the west coast of Vancouver Island. Matkin et al. (2007) found the diet of transient killer whales in the eastern Aleutians (Alaska) in spring was primarily gray whales as they transited north to their summer feeding grounds. During spring northbound migration of gray whales, Barrett-Lennard et al. (2011) also documented attacks by transient killer whales that aggregate annually as gray whales past Unimak Island, at the western end of the Alaska Peninsula, to their summer feeding grounds in the Bering and Chukchi Seas. All gray whales migrating between the Pacific Ocean and Bering Sea pass through the Unimak Island area, where they are vulnerable to predation by the aggregating orcas. Attacks were conducted by groups of three to four killer whales, which attempted to drown their prey. Gray whales generally tried to move into shallow water along the shoreline when attacked; if they succeeded in reaching depths of three meters or less, attacks were abandoned. Kills occurred in waters from 15 to 75 m deep or were moved into such areas after death. After some hours of feeding, the carcasses were usually left, but were revisited and fed on by killer whales over several days.

Less is known about killer whale predation on the gray whales' primary feeding areas in the northern Bering and Chukchi Seas, although reports by Ljungblad and Moore (1983) and Melnikov and Zagrebin (2005) indicate that it occurs in both areas. In the Bering Sea north of St. Lawrence Island, Alaska, sixteen killer whales were observed for 90 minutes as they approached and then chased gray whales (Ljungblad and Moore, 1983). In the coastal waters of Chukota Peninsula, Russia, native peoples recorded killer whales preying on gray whales during the open water season (Melnikov and Zagrebin, 2005). A killer whale predatory attack on a gray whale calf was documented by the Arctic Whale Ecology Study (ARCWEST) near Wainwright in September 2013 (Clarke et al., 2015a).

Most predatory attacks are on gray whale calves or yearlings and are quickly abandoned if calves are aggressively defended by their mothers (Jefferson, Stacey, and Baird, 1991; Ford and Reeves, 2008; Barrett-Lennard et al., 2011). The importance of this predation to gray whales has not been fully evaluated, but there is increasing evidence that predation may be a significant mortality factor. Preliminary estimates have suggested that predation by mammal-eating transient killer whales may be responsible for mortalities constituting up to 35% of the average annual calf production of ENP gray whales (Barrett-Lennard et al., 2005), but there is substantial uncertainty about assumptions underpinning this estimate. Nonetheless, it is clear that if the transient killer whale population continues to expand in the Arctic due to diminishing ice the potential for impact on gray whales would also increase.

Gray whales began to receive protection from commercial whaling by the League of Nations in the 1920s, by the government of Mexico, and then later by the IWC at its inception in 1946. However, hunting of the WNP continued for many more years. After changing the status of the recovered species to sustainable harvest, the IWC set annual quotas for gray whale harvests from the ENP for aboriginal subsistence. Subsistence hunters in Russia and the United States have traditionally harvested whales from the ENP stock in the Bering Sea, although only the Russian hunt has persisted in recent years (Huelsbeck, 1988; Reeves, 2002). In 2012, the IWC approved a 6-year quota (2013-2018) of 744 gray whales, with an annual cap of 140, for Russian and U.S. (Makah Indian Tribe in Washington State) native peoples. The U.S and Russia have agreed that the quota will be shared with

an average annual harvest of 120 whales by the Russian Chukotka people and 4 whales by the Makah Indian Tribe. Total takes by the Russian hunt during the past five years were: 130 in 2008, 116 in 2009, 118 in 2010, 128 in 2011, and 143 in 2012 (Carretta et al., 2015).

Most data on human-caused mortality and serious injury of gray whales are from strandings, including at-sea reports of entangled animals alive or dead (Carretta et al., 2015). Strandings represent only a fraction of actual gray whale deaths (natural or human-caused), as reported by Punt and Wade (2012), who estimated that only 3.9% to 13.0% of gray whales that die in a given year end up stranding and being reported. From 2008 to 2012 there were 26 human-caused deaths and serious injuries of ENP gray whales from fishery-related and marine debris as recorded by NMFS stranding networks and observer programs (Carretta et al., 2015). Although four of these cases were in Alaska, none were in the Arctic. This is unsurprising given the remote locations and also that Alaska gillnet fisheries largely lack observer programs, including those in Bristol Bay known to interact with gray whales.

Ship strikes are also a source of mortality for gray whales. Near shore industrialization and shipping congestion throughout the migratory corridors of the ENP gray whale stock represent risks by increasing the likelihood of exposure to pollutants and ship strikes. From 2008 to 2012 there were 13 ENP gray whale serious injuries and deaths attributed to vessel strikes, none of which were in Alaska (Carretta et al., 2015). Additional mortality from ship strikes probably goes unreported because the whales either do not strand or do not have obvious signs of trauma.

Climate Change

Bluhm and Gradinger (2008) examined the availability of pelagic and benthic prey in the Arctic and concluded that pelagic prey is likely to increase while benthic prey is likely to decrease in response to climate change. Ocean acidification could reduce the abundance of shell-forming organisms (Fabry et al., 2008, Hall-Spencer et al., 2008), many of which are important in the gray whales' diet (Nerini 1984). Bluhm and Gradinger (2008) also noted marine mammal species exhibiting trophic plasticity (such as gray whales which feed on both benthic and pelagic prey) would better adapt to changing Arctic conditions.

Changes in sea ice cover are likely to affect gray whales, most likely through range expansion and the possibility of gray whales recolonizing habitat of the extinct Atlantic gray whale in the Atlantic Ocean (Meade, and Mitchell, 2012; Alter Rynes and Polumbi, 2007). The recent range expansion and continued growth of the Eastern Pacific gray whale stock supports this hypothesis (Rugh et al., 2001), as do separate gray whale sightings in the Mediterranean Sea in 2010 (Scheinin et al., 2011) and off the Namibian coast in 2013 (Elwen and Gridley 2013).

The spread of disease and parasites has also been suggested as a potential threat to Arctic marine mammals by emigration/immigration events between different marine mammal populations, abetted by sea ice losses, but only in a general context. The true potential for the spread of pathogens between other whale species and gray whales remains speculative.

3.2.4.2. Ice Seals

Environmental Perceptions

Sound:

Though seals have good low-frequency hearing, they lack the highly developed auditory and sound production abilities of Odontocete cetaceans (Supin et al., 2001). Seals generally depend on vision and tactile senses to locate and capture prey (Reidman, 1990) and avoid hazards. Underwater audiograms for ice seals suggest that they have very little hearing sensitivity below 1 kHz; but hear underwater sounds at frequencies up to 60 kHz; and make calls between 90 Hz and 16 kHz (Richardson et al., 1995a). Ciminello et al. (2012) assessed the audible noise range for phocid seals

occurs between 50 Hz – 80 kHz.(Table 3.2.4-2), and their hearing thresholds for Temporary Threshold Shift (TTS) and Permanent Threshold Shift (PTS) for impulse and continuous noises are reflected in Table 3.2.4-2.

Table 3.2.4-2. Impulse and Continuous Noise TTS and PTS Thresholds for Phocid Seals.

Noise Type	TTS	PTS
Impulse Noise	212 dB Peak SPL	218 dB Peak SPL
Continuous Noise	229 dB Peak SPL	235 dB Peak SPL

Source: Ciminello et al. (2012)

Somatic:

Beyond their acoustic abilities, seals have extremely well-developed, highly innervated facial vibrissae with extremely sensitive active-touch receptors within their facial whisker pads. For example a single vibrissa of the ringed seal contains ten times the number of nerve fibers typically in one vibrissa of a land mammal and are structurally distinctive from those of land mammals (Hyvarinen, 1987), and the facial whisker pads of bearded seals have around 1300 nerve endings associated with each whisker, making them among the most sensitive in the animal kingdom (Marshall et al., 2006, as reported in Burns, 2009), though the amount of innervation in the whisker pads of other seal species should vary.

Schusterman (1981) speculated sightless seals use other non-visual, perhaps tactile, senses to locate food. The ability of harbor seals to detect and follow hydrodynamic trails out to 180 meters away has been documented (Dehnhardt et al., 2001) and research data suggests pinniped vibrissae enable seals to distinguish between different types of trail generators (i.e. prey items, currents) (Marshall et al., 2006; Wieskotten et al., 2010; Supin et al., 2001). Mills and Renouf (1986) determined harbor seal vibrissae are least sensitive at lower frequencies (100, 250, and 500 Hz), and more sensitive at higher frequencies (750+ Hz) where the smallest detectable vibration occurred at 1000 Hz.

Long and sensitive vibrissae help pinnipeds detect vibrations of prey in the water, permitting them to forage in areas with very poor visibility (Stephens et al. 1973).

Pinniped vibrissae also seem to aid in navigation, such as occurred in an experiment when a spotted seal was blindfolded and was able to consistently surface in the center of a breathing hole in the ice. When the same blindfolded seal had its vibrissae restricted it tended to bump into ice near the breathing hole several times before successfully finding and using the hole (Sonafrank et al. 1983). Montagna (1967) suggested vibrissae could also serve to gauge a seal's swimming speed though the veracity of this hypothesis has not yet been confirmed.

Vision:

As with most marine mammals, seals can see well in air and underwater within certain limits (Supin et al., 2001). Seals have very large orbits with eyes that are very large in relation to their body size, and have strong visual acuity in low-light conditions because of high numbers of rod-shaped receptors that discriminate between light levels (Riedman 1990). In the terrestrial environment seal eyes function best in bright sunlight, when the pupil contracts, at least partially offsetting their nearsightedness (Riedman 1990; Lavigne et al., 1977). Experiments on captive pinnipeds found that they can see almost as well in air as in water under good to moderate lighting conditions (Schusterman and Balliet 1971; Schusterman 1972). The seal's eye, however, remains better adapted for underwater than for aerial vision and a seal's underwater visual acuity is thought to be comparable to that of a cat on land, according to Schusterman (1972).

Though color vision has never been demonstrated for pinnipeds, seals may be able to see color to a limited degree since their eyes do contain some cones (cones allow eyes to perceive color as well as fine detail in bright light). In one experiment, a spotted seal was able to distinguish two objects that were identical except in color (Wartzog and McCormick, 1978). Experiments with California sea

lions however, suggest they do not see in color but perceive colored objects in shades of black, white, and grey (Reidman, 1990). A submerged seal would not be able to see much color anyway, since only certain light wavelengths can penetrate beneath the sea's surface, making a seal's underwater world mostly blue or green. Various pinniped species are sensitive to the blue or green light wavelengths that predominate in the particular marine environment they inhabit (Lavigne et al., 1977). For instance, southern elephant seals, which dive to great depths in open waters characterized an abundance of blue color wavelengths, possess visual pigments in their rods most sensitive to blue light. Seals living in coastal or polar waters possess more green visual pigments (Riedman, 1990).

Olfaction:

When underwater, pinnipeds seals and most other marine mammals have no known sense of smell (their nostrils usually remain tightly closed) and a limited sense of taste. Comprehensive reviews of chemoreception in marine mammals provided by Lowell and Flanigan (1980) and Watkins and Wartzok (1985) support the presumption that seals do not use a sense of smell when submerged.

Seals have retained an acute sense of smell out of water since they spend a significant amount of their life cycle out of water and retain a need to detect terrestrial threats (Riedman and Estes 1988). The sense of smell plays an especially important role in social and reproductive events that take place on land among the pinnipeds. Pinnipeds can detect the presence of humans hundreds of feet away by scent, and often slip into the water if a person is upwind. Bearded and ringed seals can scent polar bears, and the presence of polar bears is a determining factor in haul-out selection. When bearded seals haul out onto ice, they typically orient with their noses downwind and their bodies close to the water's edge. Using this orientation, a seal can visually detect a polar bear approaching from the downwind direction, and rely on their olfactory senses to scent polar bears upwind of their location (Kingsley and Stirling 1991). At the first indication a polar bear is nearby a seal oriented in such a way can quietly slip into the water to safety.

Yet another example of seals using olfaction may be observed among breeding bearded seals, since adult males often investigate a female's anogenital area to determine, presumably by chemoreception, if she is in estrus. The frequent practice of nose-to-nose nuzzling of mothers and pups is also an important means of mutual recognition and of conveying and receiving information via chemoreception (see e.g. Ross, 1972).

Bearded Seal (*Erignathus barbatus nauticus*)

Population and status

The Beringia Distinct Population Segment (DPS) of bearded seals occurs in Alaskan waters. They inhabit the Bering, Chukchi, and Beaufort seas (Burns and Frost, 1979) and their numbers are considerably higher in the Bering and Chukchi seas than in the Beaufort Sea, particularly during winter and early spring. In the 2010 status review, Cameron et al. (2010) estimated 125,000 bearded seals occur in the Bering Sea and 27,000 in the Chukchi Sea, with an overall estimate of 155,000 bearded seals in the Beringia DPS. They are listed as Threatened under the ESA and the stock is considered to be depleted by the NMFS (Muto et al., 2016).

Ver Hoef et al. (2014) estimated 61,800 bearded seals occurred in the central and eastern Bering Sea during a 2007 survey. Conn et al. (2014) estimated 245,476 - 360,544 bearded seals occurred in the Bering Sea using data from a 2012-2013 survey that was more extensive. Both the Ver Hoef et al. (2014) and the Conn et al. (2014) estimates were for the Bering Sea only and did not account for seals in the Chukchi or Beaufort Seas. Bengtson et al. (2005) conducted surveys in the eastern Chukchi Sea but could not estimate abundance from their data. Early estimates of the Bering-Chukchi seas bearded seal population ranged from 250,000-300,000 (Burns, 1981; Popov 1976). Cameron et al. (2010) developed a rough estimate of 3,150 year-round resident bearded seals in the Beaufort Sea that was uncorrected for submersed seals or seasonal migrants, and around 27,000 year-round resident bearded

seals in the Chukchi Sea. Cameron et al. (2010) estimated the maximum density of bearded seals from Prudhoe Bay to the coast south of Kivalina at approximately 0.14 seals/km². An indication of low population densities for bearded seals is also suggested by survey results conducted near the Northstar and proposed Liberty Island sites. Aerial surveys at these sites detected 3-18 bearded seals, and from 1,911- 2,251 ringed seals during Spring 1999-2001 (Moulton et al., 2000, 2001, 2003; Moulton and Elliott, 2000). Such a marked difference in the number of observed bearded vs. observed ringed seals is believed to be indicative of a small bearded seal population near the Proposed Action Area, and most likely throughout the Beaufort Sea.

Because of the widely varying population estimates over the years, a reliable minimum population of the Beringia DPS of bearded seals has not been established (Allen and Angliss, 2015); however, since no evidence suggests population declines have occurred, the stock is presumed to be healthy.

Distribution

Bearded seals have a circumpolar distribution ranging from the Arctic Ocean into the western Pacific (Burns, 1981), associating with pack ice, and only rarely using shorefast ice (Burns and Harbo 1972). In Alaskan waters, bearded seals occur over the continental shelves of the Bering, Chukchi, and Beaufort seas where they feed on benthic prey (Burns, 1981; Kelly, 1988). In winter, most bearded seals in Alaska occur in the Bering Sea, though smaller numbers of year-round residents remaining in the Beaufort and Chukchi Seas, mostly around lead systems, and polynyas. During spring (mid-April to June), most bearded seals in the Bering Sea shift northward through the Bering Strait and into the Chukchi and Beaufort Seas in tandem with the melting sea ice. Spring surveys of bearded seals in 1999 and 2000 found that they generally prefer areas of 70%-90% sea ice cover and prefer to remain 20-100 nautical miles from the coast, with a few notable exceptions (Bengtson et al., 2000; Bengtson et al., 2005; Simkins et al., 2003). Since bearded seals mostly feed on benthic invertebrates, and demersal fishes, they closely associate with areas <200 m deep (Allen and Angliss, 2015). Heptner et al. (1976), Fedoseev (1984), Nelson, Burns, and Frost (1984), and Cameron et al. (2010) found the core distribution of bearded seals occurs in waters less than 500 meters (1,640 ft) deep. Consequently there are believed to be fewer bearded seals in the Beaufort Sea and near the Proposed Action, than in the Chukchi or Bering Seas since benthic habitat is limited in the Beaufort Sea. Because of the extensive shelf size in the Chukchi Sea, the summer distribution of bearded seals in the Chukchi Sea remains large, and conversely, the narrow shelf in the Beaufort Sea supports fewer bearded seals leading to a smaller resident population of bearded seals in the Beaufort Sea. Water depths at the Liberty Site are approximately 6 meters (19 ft) deep and the sea floor is often scoured clean of benthic organisms nearer to shore and away from boulder patches. Moreover, the Proposed Action is surrounded by shorefast ice throughout the winter and early spring, and positioned several kilometers south of any lead systems making it unusable as winter habitat for bearded seals.

Bearded seals are generally solitary, tending to be widely dispersed during winter when sea ice is widespread, however they may also loosely aggregate at biologically important areas such as polynyas, lead systems, and near river mouths during winter (Gilchrist and Robertson, 2000; Kelly, 1988; Simpkins et al., 2003; Braham et al., 1984; Heptner et al., 1976, Fedoseev, 1984, Nelson et al., 1984). Most bearded seals are not very selective about the type or quality of ice they use (Fay, 1974), as long as the floes are clean, and are not hummocky or highly compacted (Heptner et al., 1976; Burns and Harbo, 1977), but they usually avoid areas of continuous, thick, shorefast ice and are rarely seen in the vicinity of unbroken, heavy, drifting ice or large areas of multi-year ice (Fedoseev, 1965, Burns and Harbo, 1977, Burns and Frost, 1979, Burns, 1981, Smith, 1981, Fedoseev, 1984, Nelson et al., 1984, Kingsley et al., 1985). Although they prefer areas with immediate access to areas of open water, they sometimes create breathing holes similar to those of ringed seals (Stirling and Smith, 1975; Fedoseev, 1965; Burns, 1967; Burns and Frost, 1979; Burns, 1981; and Nelson et al., 1984), and bearded seals in the Canadian Arctic overwinter in areas of thick fast ice (Smith, 1981), by creating and maintaining breathing holes (Smith, 1981, Cleator and Smith, 1984). Fay (1974) reported

that some individuals also use their heads to break holes in ice up to 10 cm (~4 in) thick, and maintain those breathing holes in heavy ice conditions. In late fall and winter, as ice starts forming at the coasts and bays, seals are seen farther out to sea among areas of drifting, broken ice floes, and near open water (Heptner et al., 1976).

In the Beaufort Sea bearded seals are most numerous in shear zones where drifting pack ice interacts with, and grinds away fast ice, creating leads and other openings (Burns and Frost, 1979). The highest densities of bearded seals in the eastern Chukchi Sea in May and June occurs where pack ice areas that coincide with high benthic productivity areas (Bengtson et al., 2005). Surveys in the Beaufort Sea indicate bearded seals prefer areas with open ice cover and water depths primarily of 25-75 meters (Stirling et al., 1977, Stirling et al., 1982), and during summer their preferred habitat is characterized by shallow waters in areas with flowing sea-ice mostly with depths ≤ 200 meters (Burns, 1967; Burns et al., 1981; Stirling et al., 1982; Stirling, 1975; Ivashin et al., 1972). Since they mostly feed on benthic organisms, bearded seals' range is also restricted to areas where seasonal sea ice occurs over relatively shallow waters and they may forage on the bottom (Kosygin, 1971, Heptner et al., 1976, Burns and Frost, 1979, Burns, 1981, Fedoseev, 1984, Nelson et al., 1984, Fedoseev, 2000, Kovacs, 2002), and although bearded seals usually associate with sea ice, young seals may be found in ice-free areas such as bays and estuaries (ADF&G, 1994).

In some areas bearded seals use the ice year-round; however during summer they often use open-water areas in proximity to the ice front (Harwood et al., 2005; Monnett and Treacy, 2005; Kelly, 1988). At this time the most favorable bearded seal habitat occurs near the widely fragmented margin of the pack ice; although they also are found in nearshore areas of the central and western Beaufort Sea during summer, especially near river mouths.

Adult bearded seals are rarely found onshore, but some adults in the Chukchi and Beaufort Seas use haul-out sites ashore in late summer and early autumn until ice floes reappear at the coast (Kovacs, 2002; Burns, 1981; Nelson, 1981; Smith, 1981). However, younger bearded seals may haul out on the shorelines, spits, and islands in lagoon river systems in some areas near Wainwright, Alaska (Nelson 1981), and on islands near Point Barrow, Alaska (W. Adams, North Slope Borough, Department of Wildlife Management, July 14, 2010, pers. comm.; as reported in Cameron et al., 2010). In many of these locations, sea ice either melts completely or recedes beyond the limits of shallow waters where seals must feed (Burns and Frost, 1979, Burns, 1981).

NMFS listed the Beringia DPS of bearded seals as threatened under the ESA on December 28, 2012 (77 FR 76740) due to sea ice and snow cover decreases in the foreseeable future which would result in population declines that threaten the survival of the bearded seal. On July 25, 2014, the U.S. District Court for the District of Alaska issued a decision vacating the listing of the Beringia DPS of bearded seals as threatened. On October 24, 2016, the U.S. Court of Appeals for the Ninth Circuit reversed the judgment of the District Court. On February 22, 2017, the Ninth Circuit denied a petition for rehearing en banc. On May 12, 2017, the District Court entered final judgment wherein the Beringia DPS of bearded seals remains threatened under the ESA. The stock is also considered depleted under the MMPA by NMFS. Critical habitat has not been designated for the Beringia DPS of bearded seal.

Life History

Female bearded seals begin to reproduce at 5–6 years of age with 80% having delivered a pup by age 6, while males reach sexual maturity at 6-7 years (Kelly, 1988). Typically bearded seal females choose ice floes away from the shorefast ice zone, for birthing areas (Kovacs et al., 1996; Fay, 1974; Burns and Frost, 1979), giving birth to a 1.3 meter (4 ft), 33 kg (75 lb) pup on ice between mid-March and early May (Heptner et al., 1976, Fedoseev, 1984, Nelson, Burns, and Frost, 1984).

Most births occur during the last 1 ½ weeks of April somewhere around the Bering Strait (Burns, 1981; Kovacs, 2002), and the precocial pups whelp in an advanced developmental state, with a layer of subcutaneous fat, and often having wholly or partially molted in utero (Kovacs et al., 1996) or completing their first molt before the cessation of nursing. Newborn pups frequently enter the water within minutes or hours of birth and are foraging within one or two weeks (Lydersen, 2002; Watanabe et al., 2009; Lydersen et al., 1994; Kovacs et al., 1996). Upon weaning pups weigh 85 kg (190 lbs) and spend about 50% their time in the water, making ≥ 5 minute dives to depths of 84 meters (275.6 ft) (Lydersen et al., 1994; Lydersen et al., 1996; Burns, 1981; Nelson, 2008). In late-May through early June females begin ovulating (Riedman, 1990), followed by a period of courtship by male bearded seals.

Males court females and display using calls: ascents, sweeps, moans, and elaborate downward trilling vocalizations that are frequency modulated and can travel up to 30 kilometers (Cleator et al., 1989; Van Parijs et al., 2001; Van Parijs, 2003; Van Parijs et al., 2003; Van Parijs et al., 2004; Van Parijs and Clark, 2006), bubble displays, and diving displays (Burns, 1981, 1988, 2009; Van Parijs 2003; Cleator et al., 1989). Individual males use distinct songs, and may occupy the same territories over a series of consecutive years within constraints imposed by variable ice conditions, or they may show a roaming pattern (VanParijs et al., 2001, 2003, 2004). Mating calls peak during and after pup rearing (Wollebaeck, 1927; Freuchen, 1935; Dubrovskii, 1937; Chapskii, 1938), and evidence suggests these calls originate only from males (Burns, 1967; Poulter, 1968; Ray et al., 1969; Burns, 1981; Stirling et al., 1983; Cleator et al., 1989; Cleator and Stirling, 1990; Van Parijs et al., 2001; Van Parijs et al., 2003; Van Parijs et al., 2004; Davies et al., 2006; Van Parijs and Clark, 2006; Risch et al., 2007). The vocalizations of male bearded seals are believed to advertise mate quality, signal competing claims on reproductive rights, or to identify territory. Recent studies in the fjords of the Svalbard Archipelago and shore leads in the Chukchi Sea of Alaska have suggested site fidelity of males within and between years supporting earlier claims that males defend aquatic territories (Cleator et al., 1989; Cleator and Stirling, 1990; Van Parijs et al., 2003; Van Parijs et al., 2004, Van Parijs and Clark, 2006, Risch et al., 2007). Males exhibiting territoriality maintain a ≤ 12 km² core area, unlike wandering males that call across several larger core areas (Van Parijs et al., 2003; Van Parijs et al., 2004; Van Parijs and Clark, 2006; Risch et al., 2007), and scars on the males suggest fighting may be involved in defending territories as well.

Copulation is followed by a 2-2.5 month period of delayed implantation in females, where the fertilized embryo remains in stasis, before attaching and implanting into the uterine wall. After the delay is over an embryo completes the implantation process and begins the 8 ½ month period of gestation. The total gestation period for bearded seals is from 11 to 11 ½ months long, allowing a pup to be birthed during spring when environmental conditions favor a pups survival (Burns, 1981, 1988; Burns and Frost, 1979).

In June, after whelping and breeding conclude, most bearded seals begin their annual molt spending much of their time hauled out on ice, entering water with reluctance (Kovacs et al., 2004). Some individuals may be observed molting between April and August, but the process peaks in June (Burns, 1981). Sea ice is an important requirement for the molt since it provides bearded seals with an elevated, dry platform where they can raise their skin temperature, which facilitates epidermal growth (Feltz and Fay, 1966).

The diving behavior of adult bearded seals is closely related to their benthic foraging habits and in the few studies conducted so far, dive depths have largely reflected local bathymetry (Gjertz et al., 2000, Krafft et al., 2000). Adult females spent most of their dive time (47-92%) performing U-shaped dives, believed to represent bottom feeding (Krafft et al., 2000); U-shaped dives are also common in nursing pups (Lydersen et al., 1994b).

Diet

Bearded seal diets vary with age, location, season, and changes in prey availability (Kelly, 1988). Quakenbush et al. (2011b) found bearded seals most commonly consume invertebrates, which were found in 95% of stomach samples. They are mostly benthic feeders (Burns, 1981), consuming a variety of invertebrates (crabs, shrimp, clams, worms, and snails) and other prey species, including Arctic and saffron cod, flounders, sculpins, and octopuses (Kelly, 1988; Reeves, Stewart, and Leatherwood, 1992; ADF&G 1994; Cameron et al., 2010; Burns, 1981; Hjelset et al., 1999). They primarily feed on or near the bottom, diving is to depths of less than 100 meters though capable of going much deeper (adult dives have been recorded at 300 meters (984 ft) and juveniles have been recorded diving down to almost 500 meters (1,640 ft) (Gjertz et al., 2000)). Unlike walrus that “root” in the soft sediment for benthic organisms, bearded seals “scan” the surface of the seafloor with their highly sensitive whiskers, burrowing only in the pursuit of prey (Marshall et al., 2006, 2007, 2008). Bearded seals also feed on ice-associated organisms when practicable, allowing them to live in areas with water depths considerably deeper than 200 meters if necessary. Satellite tagging indicates that adults, subadults and to some extent pups maintain some level of site fidelity to feeding areas, often remaining in the same general area for weeks or months at a time (Cameron, 2005; Cameron and Boveng, 2009). Diets may vary with age, location, season, and possible changes in prey availability (Kelly, 1988).

In the Bering and Chukchi Seas, snow crab is the most important prey, followed by the crab *Hyas coarctatus*, while the reverse was true farther north. Shrimp species, gastropods, and octopus are important in both the northern and southern Bering Sea and the Chukchi Sea. The diet is similar in the Beaufort Sea with the addition of Arctic cod (*Boreogadus saida*) (Burns, 1981). Antonelis et al. (1994) found that 86% of bearded seals examined in the central Bering Sea in early spring had fish in their stomachs. In order of importance these were capelin (*Mallotus villosus*), codfishes (Gadidae), and eelpouts (*Lycodes spp.*). Lowry et al. (1980) reported similar findings on percentage of the occurrence of fish in stomachs, but reported that fish as a percent of total volume was 16% from May through September, and dropped to 5% for October through April. The majority of invertebrate prey items identified in the 2000s were mysids, isopods, amphipods, and decapods (Quakenbush, 2011b). Bearded seals switch their diet to include schooling pelagic fishes when advantageous, and fish consumption by Bering Sea and Chukchi Sea bearded seals increased between the 1970s and 2000s, but not to a statistically significant degree. Sculpin, cod, and flatfishes were the dominant fish taxa consumed by bearded seals in the 2000s (Quakenbush et al., 2011b).

Mortality

Bearded seals are an important subsistence species for Alaskan Native hunters. The number of seals taken annually varies considerably between years due to ice and wind conditions, which impact hunters’ access to seals. The ADF&G maintains a database, and the best estimate of bearded seals taken annually is 6,788 (Allen and Angliss, 2015).

Annual mortalities of bearded seals from commercial fishing activities is approximately 1.83 (2) bearded seals per year, and due to the lack of a reliable minimum abundance estimate, no estimate for the Potential Biological Removal (PBR) of this species can be produced at this time (Allen and Angliss, 2015). Likewise, there are no baseline population estimates for this species, making population trend calculations unfeasible.

Bearded seals are also preyed upon by polar bears, killer whales, and potentially walruses. Polar bears attack bearded seals while they rest on the ice, but the frequency of predation or importance of bearded seals to polar bears is unknown. Stirling and Archibald (1977) determined that bearded seals played a more important role in polar bear diets in the western Arctic than in most other areas, although many more ringed seals are killed annually by polar bears. Killer whales are believed to predate bearded seals, but only opportunistically when they encounter the seals in open water in the

Bering and Chukchi Seas. Bearded seal skin has been found in walrus stomachs but it is unclear whether it was an incident of walruses killing a bearded seal or scavenging a carcass. Lowry and Fay (1984) determined Pacific walruses may actively kill and consume ice seals, although most of the remains were from neonates or juveniles.

Climate Change

The climatic aspects of climate change were described in Section 3.1.6., suggesting the environmental conditions in the Beaufort Sea could change drastically in the future. These changes are a primary concern for Beringian DPS of bearded seals, particularly projected loss of sea-ice cover, which could pose a significant threat to the persistence of these seals in the future (based on projections through the end of the 21st century) (Muto et al., 2016). Laidre et al. (2008) assessed the sensitivity of bearded seals to nine environmental variables, and found they were the most sensitive to sea ice changes, and population size and habitat specificity to a lesser degree. Available information indicates a moderate to high threat that reductions in spring and summer sea ice would result in spatial separation of sea ice resting areas from benthic feeding habitat (77 FR 76740, December 28, 2012).

NMFS (Federal Register 2012) determined it is likely reductions in the extent and timing of sea ice in the range of the Beringia DPS will occur in the foreseeable future, particularly in the Bering Sea. To adapt to this modified ice regime, bearded seals would likely have to shift their nursing, rearing, and molting areas to ice-covered seas north of the Bering Strait, where projections suggest a potential for the ice edge to retreat to deep waters of the Arctic basin. Such an event would force seals into suboptimal conditions and habitats, and likely compromising reproduction and survival.

Likewise, NMFS (Federal Register 2012) also determined reductions in sea ice suitable for bearded seal molting (≥ 15 percent ice concentration in May-June) and whelping (≥ 25 % ice concentration in April-May) could occur.

Within the foreseeable future, the risks to the persistence of the Beringia DPS appear to be moderate (abundance and diversity) to high (productivity and spatial structure). NMFS determined the Beringia DPS is not in danger of extinction throughout all of its range, but could become so by around 2095 (USC, 2016). Consequently NMFS (Federal Register 2012) concluded the Beringia DPS of bearded seals is under no present threat from climate change, but future changes in sea ice could present an increasing threat leading to the extinction of the Beringia bearded seal DPS by around 2095.

The spread of disease and parasites has also been suggested as a potential threat to Arctic marine mammals by emigration/immigration events between different marine mammal populations, abetted by sea ice losses, but only in a general context. The true potential for the spread of pathogens between bearded seal stocks and other species of seals remains speculative.

Ringed Seal (*Phoca hispida hispida*)

Population and status

Ringed seals in U.S. waters are considered to be from a single Alaska stock (Kelly et al., 2010; Allen and Angliss, 2015). Kelly et al. (2010) estimated over 300,000 ringed seals inhabit the Beaufort, Chukchi and Bering Seas based on information from existing surveys and studies, though this estimate is unreliable (Allen and Angliss, 2015) and seal numbers are believed to number considerably more in the Bering and Chukchi seas, particularly during winter and early spring (71 FR 9783, February 27, 2006). Bengston et al. (2005) reported an abundance estimate of $252,488 \pm 47,204$ ringed seals in the eastern Chukchi Sea seals in 1999, and $208,857 \pm 25,502$ seals in 2000; while Frost and Lowry (1981) estimated 80,000 ringed seals in the Beaufort Sea during summer and 40,000 during winter. These were minimum population estimates and fall short of the western Arctic ringed seals total population size since the estimates do not include data from the stock's remaining geographic range. Kelly et al. (2010) estimated the Arctic ringed seal population to number over

1,000,000. However, the estimate for the U.S. Beaufort Sea has not been corrected for the number of ringed seals not hauled out at the time of the surveys (Allen and Angliss, 2015). Some authors (Amstrup, 1995) believe the Beaufort Sea population could be four times greater than the Frost and Lowry (1981) numbers. Kelly et al. (2010) placed the maximum density estimate of ringed seals at Prudhoe Bay and along the coast south of Kivalina to be 1.62 seal /km².

Population-trend analyses by Frost et al. (2002) for the central Beaufort Sea found a substantial decline of 31% in observed ringed seal densities from 1980-1987 and 1996-1999; however, Frost et al. (2002) also noted the decline may have been due to a difference in survey timing rather than an abundance decline. Spatial and temporal comparisons typically assume the proportion of animals visible remains constant between surveys; however, Frost et al. (2004) cautioned against comparing survey results because of marked between-year variation in density estimates common for ringed seal surveys. Most likely these timing differences were due to the variations in sea ice conditions and the annual molt cycles of ringed seals (Frost et al., 2004). Kelly (2005) found aerial surveys can underestimate ringed seal densities by factors of >13, because the proportion of seals visible during survey periods may rapidly change from day to day. Consequently comparisons of ringed seal densities between regions and between years based on aerial surveys should only account for the proportion of the population visible during each survey (i.e., appropriate correction factors would need to be used) (Kelly, 2005).

Ringed seals were listed as threatened under the ESA on December 28, 2012 (77 FR 76705), due to concern about the anticipated long-term effects of climate change on the pupping and denning habitat into the next century. Due to their listing under the ESA, Arctic ringed seals were subsequently listed as a depleted, and as a strategic stock (Angliss and Outlaw, 2015).

Distribution

Ringed seals are the most common and widespread seal species in the Alaskan Arctic. During the fall most ringed seals in the Beaufort and Chukchi Seas follow the sea ice front south into the Bering Sea where they remain until the lead systems and warming weather permit them to return to the Arctic during the spring and summer, and a much smaller portion of the Alaska ringed seal stock remains in the Beaufort and Chukchi Seas throughout the year. Harwood et al. (2012) tracked ringed seal migrations from the eastern Beaufort Sea to the Bering Sea, and found that ringed seals made a rapid, synchronized, westward migration into the Chukchi Sea using the same migration corridor and route that bowhead whales used.

Ringed seals have a circumpolar distribution from approximately 35° N. latitude to the North Pole, and they occur in all seas of the Arctic Ocean (King, 1983). In the Chukchi Sea areas of high concentrations occur between Point Lay and Cape Lisburne, Alaska; however no definitive ringed seal concentration areas have been identified in the Beaufort Sea other than in Canadian waters near Tuktoyuktuk.

Moulton et al. (2002) found the highest ringed seals concentrations occurred on stable, shorefast ice over water depths of about 10-20 meters in winter and spring, and Frost et al. (2004) found ringed seal densities greater with depths between 5 and 35 m. Seals cannot overwinter in ice-covered waters shallower than 3-5 meters because of ice freezing to the seafloor and/or poor prey availability resulting from a limited water supply (71 FR 9785). Thus, it can be safely assumed that waters less than 5 meters deep would be poor wintering areas for ringed seals. Optimal wintering areas for ringed seals in the Beaufort Sea should occur in waters between 10 and 35 meters deep, preferably in the shorefast ice close to lead systems. Historically, the population densities of ringed seals have been substantially greater in the eastern Beaufort Sea than in the western Beaufort (Burns and Kelly, 1982; Kelly, 1988), likely due to the shallower water depths between the shore and barrier islands in the western Beaufort Sea. Ringed seal population densities tend to be greatest on areas of flat ice near the edge of the shorefast ice zone and decline away from that edge (Frost et al., 2004).

Stirling, Kingsley, and Calvert, (1981) found ringed seal population densities in the Beaufort Sea greatest in water with >80% ice cover. During summer Simpkins et al. (2003) found ringed seals most often occurred along receding ice edges or farther north in pack ice, favoring ice floes >48 meters in diameter and in the interior pack ice, where sea-ice concentrations exceed 90%.

Surveys flown from 1996-1999 found the highest density of seals along the central Beaufort Sea coast in Alaska occurred between Kaktovik and Brownlow Point, possibly due to a productivity of zooplankton which was about four times greater there than in other areas of the eastern Beaufort Sea (Frost et al., 2004).

In early summer, the highest densities of ringed seals in the Chukchi Sea are found in nearshore shorefast ice, pack ice (Bengston et al., 2005), lead systems, polynyas, and shear zones. This trend also appears to be true in the Beaufort Sea, based on incidental sightings of seals during aerials surveys for bowhead whales (Monnett and Treacy, 2005). During summer, ringed seals are found dispersed throughout open-water areas, though in some regions they move to coastal areas (Smith, 1987; Harwood and Stirling, 1992). In late summer and early fall, ringed seals often aggregate in open-water areas where primary productivity is thought to be high (Harwood and Stirling, 1992).

Aerts et al. (2013a) analyzed the distribution of marine mammals using data collected in 2008-2010, and found the distribution of seal species was due to food availability. More specifically Aerts et al. (2013a) noted ringed seals spend 90% of their time foraging in the water during the summer and because of a highly flexible diet and high prey mobility, ringed seals lacked a clear distribution pattern.

The construction site for the Proposed Action lies well inside the shorefast ice zone, far from the edge of the shorefast ice, and in water depths of about 5.8 meters (19 ft), indicating the location would be a very poor choice of winter habitat for ringed seals. Therefore it is highly unlikely many, if any, ringed seals would occur in the immediate vicinity of the Proposed Action during winter and early spring. Because this area is often ice free during the summer, there is a strong likelihood some ringed seals would frequent the Proposed Action Area during the ice free period as food resources permit.

Critical habitat has been proposed for the Arctic ringed seal in U.S. waters and includes:

All the contiguous marine waters from the “coast line” of Alaska as that term has been defined in the Submerged Lands Act (“the line of ordinary low water along that portion of the coast which is in direct contact with the open sea and the line marking the seaward limit of inland waters”), 43 U.S.C. 1301(c), to an offshore limit within the U.S. Exclusive Economic Zone (EEZ). The boundary extends offshore from the northern limit of the United States-Canada land border (from the ordinary low water line of the Beaufort Sea at 141° W. long.) and follows the outer extent of the U.S. EEZ boundary north and slightly northeastward; thence westerly and southwesterly; thence southerly and southwesterly to 60°31' N. lat., 179°13' W. long. From there it runs southeasterly to 58°22' N. lat., 170°27' W. long.; thence easterly to 59° N. lat., 164° W. long. The boundary then follows 164° W. long. due north to the coast line of Alaska southeast of Cape Avinof.

Such a designation would effectively include all marine waters within the Exclusive Economic Zone (EEZ) of the United States where sea ice regularly forms during winter (Figure 3.2.4-14). The final determination for ringed seal critical habitat from the NMFS remains pending.

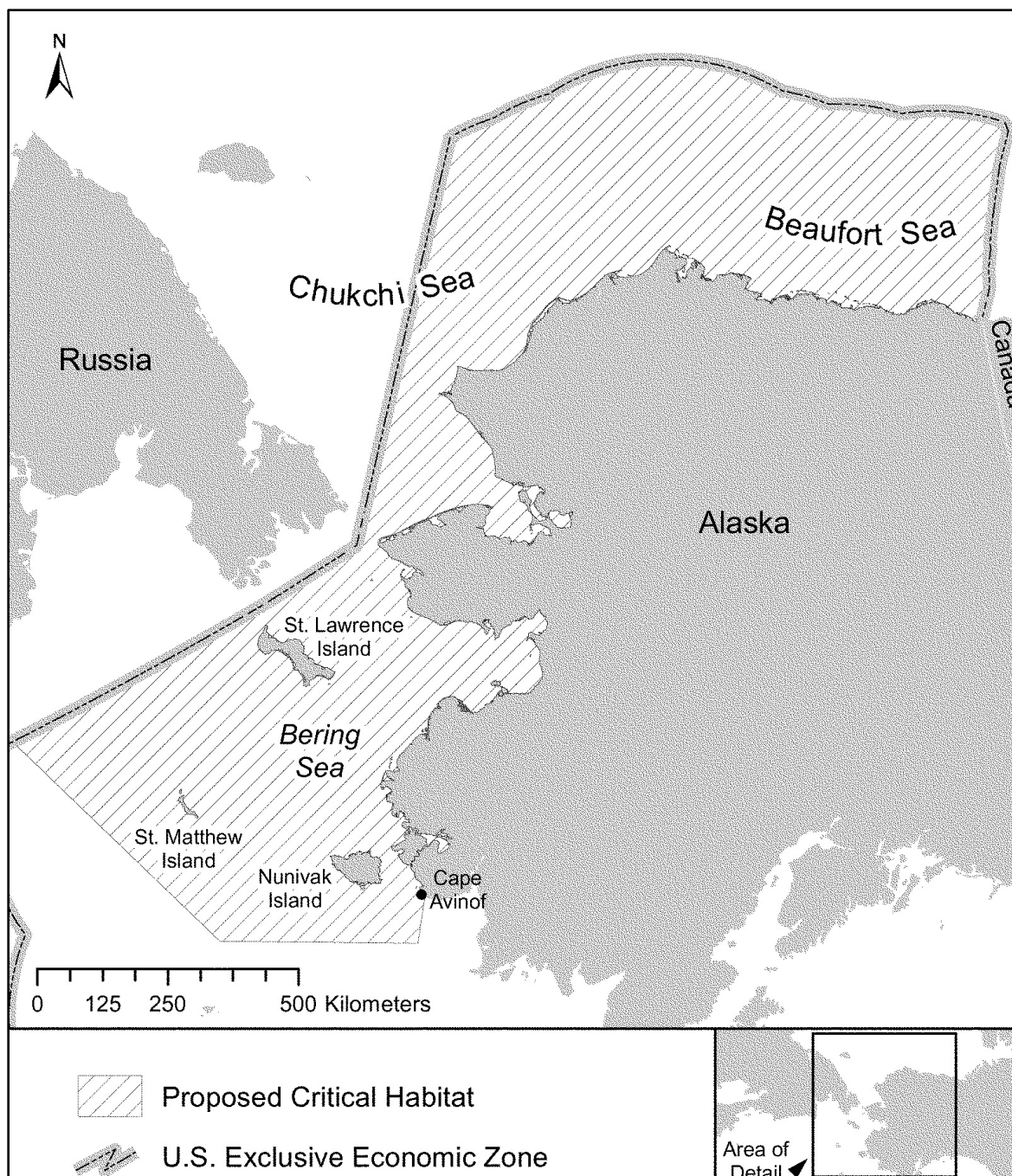

Figure 3.2.4-14. Proposed Critical Habitat for the Arctic Ringed Seal in U.S. Waters. *Source: NMFS, 2015).*

Life History

Reported mean age at sexual maturity (MAM) for ringed seals females varies in the literature from 3.5 – 7.1 years (Holst and Stirling, 2002; Krafft et al., 2006). Males likely do not participate in breeding before they are 8 and 10 years old. The average size of adults 10 years and older varies between locations and different age cohorts, but averages of 115-136 cm (3.77 - 4.46 ft) in length and 40-65 kg (88-143 lbs) in weight have been reported, with males being slightly larger than females (Smith, 1973; Frost and Lowry, 1981; Smith, 1987; Lydersen and Gjertz, 1987). Ringed seals are long lived, with ages close to 50 reported (Lydersen and Gjertz, 1987), though the average lifespan is

around 25 to 35 years (Smith and Walker, 1995). Reproductive rates of adult female ringed seals vary between 0.45-0.86 (see Reeves, 1998), with a maximum of 0.91 (Lydersen and Gjertz, 1987). Regional production rates are variable; reproductive success depends on many factors including prey availability, the relative stability of the ice, sufficient snow accumulation prior to the commencement of breeding, etc. (e.g., Lukin, 1980; Kelly, 1988; Smith, 1987; Lydersen, 1995).

Some ringed seal behaviors remain poorly understood because they spend so much of their time out of sight in their lairs or under the sea ice (ADF&G, 1994). When submerged under the sea ice ringed seals excavate and maintain several breathing holes throughout the winter to provide air-access while hunting prey species (e.g. Arctic Cod) and to provide escape routes from polar bears and other predators (Frost et al., 2002).

A single 4.0-4.5 kg (8.8-9.9 lb) pup is born in the spring (March-May), with the peak of pupping occurring in early April (Frost and Lowry, 1981). Births occur in subnivean lairs excavated in the snowpacks that accumulates upwind and downwind of ice ridges (Smith and Stirling, 1975; Furgal et al., 1996), or in cavities occurring between ice chunks in pressure ridges (McLaren, 1958; Kelly, 1988). Snow depths of at least 50-65 cm are required for functional birth lairs (Smith and Stirling, 1975; Lydersen and Gjertz, 1986; Kelly, 1988; Lydersen, 1998; Lukin et al., 2006), and such depths typically are found only where 20-30 cm or more of snow has accumulated on flat ice and then drifted along pressure ridges or ice hummocks (Lydersen et al., 1990; Hammill and Smith, 1991; Lydersen and Ryg, 1991; Smith and Lydersen, 1991). These lairs provide thermal protection against cold temperatures, wind chill, and some protection from predators (Smith, 1976, 1980; Smith and Stirling, 1975; Gjertz and Lydersen, 1986). Shore-fast ice is the best habitat for pupping, though many ringed seals successfully whelp and rear their pups in pack ice in some areas (Wiig et al., 1999). Seal mothers move young pups between lairs within their network of lairs (usually 4-6 per female) if one or more lairs are compromised and older pups can travel between lairs as their swimming skills develop (Lydersen and Hammill, 1993a, b).

Reproductive rates for ringed seals are capable of approaching 95% annually (Smith, 1973; Burns, 1981; Quakenbush and Sheffield, 2006); however, current reproductive rates appear to be lower than the maximum recorded for this species. For example only 69% of female ringed seals sampled in the Bering and Chukchi seas between 2000 and 2005 were pregnant (Quakenbush and Sheffield, 2006).

After a 5-8 week lactation period pups wean when approximately 20 kg (44 lbs) (Lydersen and Kovacs, 1999, Hammill et al., 1991; Lydersen and Hammill, 1993), then their mothers mate sometime between April and May (Moulton et al., 2002). Sometime after breeding activities conclude at about mid-May, ringed seals begin shedding their old pelts in a process known as molting.

Molting for ringed seals occurs between mid-May to mid-July, and during this time they remain hauled out on the edge of the pack ice, or on remnant landfast ice until their old pelt dries out and sheds (Reeves, 1998). Because of the need for dry skin during the molt, ringed seals refrain from entering the water and forgo foraging activities, making the molt a particularly stressful time from this species (Ryg et al., 1990).

When not whelping, lactating, breeding or molting, ringed seals travel widely and may occur in waters of nearly any depth, though their distribution remains strongly correlated with the presence of sea ice and with food availability (e.g. Simpkins et al., 2003, Freitas et al., 2008).

Diet

Most ringed seal prey is small, and selection concentrations on schooling species that form dense aggregations, in the 5-10 cm (2-4 in) length range for fishes and the 2-6 cm (0.8-2.4 in) length range for crustaceans. Typically, a variety of 10-15 prey species are found with no more than 2-4 dominant prey species in any given area. Fishes are generally more commonly eaten than invertebrate prey when available. Diet is determined to some extent by the seasonal availability and nutritive value of

prey, with pronounced seasonal variation. Depth of water and distance from shore are also factor into the ringed seal's diet (Lowry, Frost, and Burns, 1979; Reeves, 1998; Wathne et al., 2000). Ringed seals can consume the largest quantities of foods with the least energetic expenses where prey species are highly concentrated, such as with Arctic cod and nektonic crustaceans in some areas.

In U.S. waters, ringed seals mostly feed on Arctic cod and shrimp during fall, winter, and spring; and switch to amphipods and euphausiids during summer (Kelly, 1988; Reeves, Stewart, and Leatherwood, 1992; Lowry, Frost, and Burns, 1979). However, nearshore samples from the vicinity of the Proposed Action Area in 1978 found amphipods to be the primary food items in November (Lowry, Frost, and Burns, 1979). There are differences in the diet content for different ringed seal demographic groups though, and Arctic cod tends to become more prevalent in the diet of as ringed seals mature (Dehn et al., 2007), and conversely, invertebrates often dominates the diet of young animals (Lowry et al., 1980; Holst et al., 2001).

Quakenbush et al. (2011a) provided corroborating evidence that the diet of Alaska ringed seals sampled consisted of cod, amphipods, and shrimp. Fish were consumed more frequently in the 2000s than in the 1960s and 1970s, and Arctic cod, saffron cod, sculpin, rainbow smelt, and walleye pollock were identified as the dominant fishes, while mysids, amphipods, and shrimp, were the dominant invertebrate species in ringed seal diets. Aerts et al. (2013a) also found Arctic cod was the main food source for ringed seals in fall and winter, while, ringed seals had a tendency to prefer crustaceans in spring and summer.

Ringed seals in the eastern Beaufort Sea also have exhibited reduced reproductive output and reduced body condition between 2003 and 2005. Local fishermen in the eastern Beaufort Sea have suggested the downturn in seal body condition was related to decreases in marine productivity in the area, as evidenced by recent reductions in fishing opportunities for Arctic cod in the same areas that seals hunt (Harwood, 2005). Reduced numbers of Arctic cod probably also are a factor in reduced seal reproductive output, as successful ovulation depends on body condition (Harwood, 2005).

Mortality

Ringed seals are an important species for subsistence practitioners. The number of seals taken annually varies considerably between years due to ice and wind conditions, which impact hunter access to seals. The Alaska Department of Fish and Game (ADF&G) maintains a subsistence-harvest database and, as of August 2000, the mean estimate of ringed seals taken annually is 9,567, and data from 2008–2012 shows an annual average of 4.12 mortalities of Arctic ringed seals from commercial fishing operations in Alaska (Allen and Angliss, 2015).

Polar bear predation remains the largest source of ringed seal mortality, followed by subsistence hunting which is the largest source of anthropogenic ringed seal mortality. Other sources of mortality among ringed seals include entanglements and commercial fishing, and predation from Arctic foxes, walruses, wolves, wolverines, and ravens which also kill ringed seals occasionally, all of which result in a very few losses (ADF&G, 1994; 2011b; Allen and Angliss, 2013).

Allen and Angliss (2015) was unable to determine the PBR for ringed seals since the data used to produce the most recent NMFS abundance estimate (Kelly et al., 2010) was more than 8 years old, making minimum population sizes obsolete. Likewise, current population trends are unavailable since past surveys that suggested density declines may have been due to differences in the timing of those surveys and not actual population declines, and those surveys only covered a fraction of the species range.

Climate Change

Ringed seal sea-ice and snow habitats are believed to have been modified by the warming climate and projections suggest continued or accelerated warming in the future (Kelly et al., 2010). Climate

models project ice and snow cover losses throughout the 21st century, with some variations, and increasing atmospheric concentrations of greenhouse gases are driving climate warming and increasing ocean acidification (Section 3.1.6.), which affects ringed seal habitat. Such changes also threaten prey communities on which ringed seals depend. Laidre et al. (2008) analyzed life history features of ringed seals and concluded they are highly sensitive climate.

The greatest impacts to ringed seals from climate change would manifest in less snow cover. While winter precipitation is forecasted to increase in a warming Arctic (Walsh et al., 2005), the duration of ice cover could be reduced, leading to lower snow accumulation on ice (Hezel et al., 2012), particularly over their subnivean lairs. According to NMFS climate model projections, snow cover is expected to be inadequate for the formation and occupation of lairs within this century over the Alaska stock's entire range (Kelly et al., 2010).

Without lairs, ringed seals and their pups may experience increased incidents of freezing and predation (McLaren, 1958; Lukin and Potelov, 1978; Lydersen and Smith, 1989; Stirling and Smith, 2004). Changes in the ringed seal's habitat could occur rapidly relative to their generation time which could limit adaptive responses.

The spread of disease and parasites has also been suggested as a potential threat to Arctic marine mammals by emigration/immigration events, abetted by sea ice losses, but only in a general context. The true potential for the spread of pathogens between ringed seal stocks and other species of seals remains speculative.

Spotted Seal (*Phoca largha*)

Population and status

Allen and Angliss (2015) noted a spotted seal population estimate of 391,000 for the Alaska Stock, citing Conn et al. (2014). The lower and upper limits for a Ver Hoef et al. (in review) estimate were 92,769-321,882 individuals, however Allen and Angliss (2013) noted that no reliable minimum population estimate or number for the PBR was available. The vast majority of spotted seals occur in the Bering and Chukchi Seas, with much lower numbers present in the Beaufort Sea, as evidenced by the smaller haulouts found along the Beaufort Sea coast between Oarlock Island in the eastern Colville River Delta and Smith Bay near Point Barrow.

Distribution

The Alaska stock of spotted seals are distributed along the continental shelf of the Beaufort, Chukchi, and Bering seas, mostly in shallow and/or nearshore waters (Shaughnessy and Fay, 1977; Lowry et al., 2000). They are mostly seen in bays, lagoons, estuaries, and nearshore waters but they also range far offshore to 72° N. latitude (Shaughnessy and Fay, 1977). They are common in the coastal Alaskan waters in ice-free seasons and are not known to remain in the Beaufort Sea during the late fall and winter. They migrate south from the Chukchi Sea through the Bering Strait in October-November to overwinter in shallow areas along the ice front (Lowry et al., 1998; Lowry et al., 2000). In spring spotted seals overwintering in the Bering Sea follow the receding sea ice, north through the Bering Strait into Chukchi and Beaufort Sea to reoccupy their seasonal coastal habitats (Shaughnessy and Fay, 1977; Simpkins et al., 2003).

Spotted seals make foraging trips from coastal haulouts lasting about 9 days, followed by a rest period of one to two days at a coastal haulout. No surveys of potential spotted seal haulouts on sea ice in the Beaufort Sea have been conducted to date due to personnel safety hazards. Known spotted seal onshore haulouts are known to exist in Smith Bay, Dease Inlet, the Colville River Delta, and historically in the Sagavanariktok River Delta, and possibly in western Camden Bay, Alaska (Huntington, 2013; Smith et al., 2010; ADF&G, 2015; NOAA, 2015; ASGDC, 2012). Some unverified accounts of spotted seals recently hauling out in the Sagavanirktok River Delta have been

discussed during scoping. Haulout sizes in the Beaufort Sea tend to be much smaller than those along the Chukchi and Bering Sea coasts, sometimes by one or two orders of magnitude, indicating spotted seals have a lesser presence in the Beaufort Sea than in other areas of their range.

Seals at the Beaufort Sea haulouts have historically numbered into the hundreds, even at the easternmost documented haulout on Oarlock Island. Recently, only a few tens of spotted seals have been observed at Oarlock Island. This decrease in spotted seal numbers has occurred since the 1970s, coinciding with the establishment of Nuiqsut along the Colville River. Whether or not the creation and presence of the town of Nuiqsut in 1970, and the associated subsistence harvest has led to the decline of the Oarlock Island haulout site remains unknown. It is possible that population declines at the Oarlock Island haulout shows that seals have shifted to other haulout locations in the Beaufort Sea. Marine mammal monitoring during BPXAs 2014 Shallow Geohazard Survey (Smultea et al., 2014) at the Liberty site noted an estimated 80 spotted seals in the area during seismic surveying, easily making spotted seals the most commonly observed pinnipeds in the area with most occurrences south and east of Narwhal Island. A concurrent ocean bottom sensor seismic survey at the same site by BPXA found 31% of the marine mammal sightings were spotted seals and another 31% were ringed/spotted seals (Lomac-MacNair et al., 2015). This information from two concurrent marine mammal monitoring reports suggests spotted seals in the Proposed Action Area should number in the high 10s to low 100s.

Life History

During spring when pupping, breeding, and molting occur, spotted seals inhabit the southern margin of the sea ice in the Bering Sea (Quakenbush, 1988; Rugh, Shelden, and Withrow, 1997). Of eight known breeding areas, three occur in the Bering Sea (Angliss and Outlaw, 2005). Pupping occurs on ice in April and May, and pups are weaned within 3-4 weeks. Adult spotted seals often are seen on the ice in female-pup or male-female pairs, or in male-female-pup triads. Mating occurs around the time the pups are weaned and mating pairs are monogamous for the breeding season. Spotted seals are rarely seen on the pack ice during the summer, except when the ice is very near shore.

Diet

Spotted seals have a flexible diet and are opportunistic predators, though schooling fish are their preferred prey (Aerts et al., 2013a; Dehn et al., 2007; Boveng et al., 2009). Boveng et al. (2009) found spotted seals are generalist feeders with a varied diet, though fishes are main prey group in their diet, with large numbers of crustaceans and cephalopods showing up food analyses. Dehn et al. (2007) found nitrogen isotope ratios of spotted seals indicated feeding in higher trophic levels than other ice seals and carbon isotope analyses indicated spotted seals mainly forage in the pelagic environment with much less reliance on the benthic environment when compared to bearded seals and Pacific walrus. Data from 2008-2010 led Aerts et al. (2013b) to conclude spotted seal presence in the Chukchi Sea is determined by food availability, reflecting the influence of oceanographic conditions on prey species; a conclusion that should apply to spotted seals in the Beaufort Sea too. Consequently, the site locations of Beaufort Sea spotted seal haulouts is likely due to the presence of spawning runs of whitefish and salmon more than any other single factor. Since spotted seals are shallow water divers, mostly feeding in waters <200 meters deep (Bukhtiyarov et al., 1984; Lowry; 1985), the amount of available feeding habitat in the Beaufort Sea will always remain limited due to the marginal extent of the continental shelf, which explains why there are much fewer spotted seals in the Beaufort Sea than in the Chukchi and Bering Seas.

Mortality

The best estimate of the statewide annual spotted seal subsistence harvest is 5,265, and data from 2008–2012 shows an annual average of 1.52 spotted seal mortalities from commercial fishing operations in Alaska (Allen and Angliss, 2015). As with the analogous ringed seals, polar bear

predation is the largest source of mortality, and subsistence hunting is the largest source of anthropogenic mortality; other sources, such as entanglements and commercial fishing are very low (Allen and Angliss, 2013). No information exists regarding the numbers of spotted seals killed annually by predators such as killer whales, grizzly bears, Pacific walruses, sleeper sharks, etc.; the numbers of such losses are believed to be very low since the habitat preferences of ringed seals would making the practice of hunting ringed seals problematic for most predators other than polar bears.

Climate Change

Spotted seal sea-ice habitat has been modified by the warming climate should continue to change into the future (Muto et al., 2016). Though the Arctic Ocean ice extent has been shrinking during summer, winter sea ice in the Bering Sea should continue forming annually into the foreseeable future. There could be more frequent years in which ice coverage is reduced, resulting in long-term declines in ice extent, but Bering Sea spotted seals would likely continue to encounter sufficient ice to support adequate vital rates. Laidre et al. (2008) concluded spotted seals were likely to be moderately sensitive to climate change based on various life history features.

A second major concern is ocean acidification, which could alter prey and other habitat characteristics. Ocean acidification could impact spotted seal survival and recruitment through disruption of trophic regimes that are dependent on calcifying organisms; however spotted seals' dietary flexibility makes such a threat less of a concern than sea-ice degradation (Boveng et al., 2009). If conditions begin to favor the pelagic environment in the Beaufort Sea, they may favor spotted seals during the open water season since adult spotted seals are usually piscivorous, and pelagic foodwebs often favor fishes. Consequently there could be a greater presence of spotted seals using the Beaufort Sea, and Foggy Island Bay during the open water season, at least for as long as ocean acidity doesn't prevent fish populations from remaining viable in the region.

The spread of disease and parasites has also been suggested as a potential threat to Arctic marine mammals by emigration/immigration events, abetted by sea ice losses, but only in a general context. The true potential for the spread of pathogens between other species of seals and spotted seals remains speculative.

3.2.4.3. Pacific Walrus

In-depth descriptions of the status, distribution, life history, and survival of Pacific walrus populations occurring in U.S. waters, including the Beaufort Sea, are provided in The USFWS Status Review of the Pacific Walrus (*Odobenus rosmarus divergens*) (Garlich-Miller et al., 2011, the most recent USFWS stock assessment report (USFWS, 2014), and Conference Opinions (USFWS, 2011, pages 17-20; USFWS, 2013, pages 18-26). The following text summarizes pertinent information from these documents, which are incorporated by reference, and includes new scientific information when available.

Sound. Walruses produce a variety of sounds (barks, knocks, grunts, rasps, clicks, whistles, contact calls, etc. (Miller, 1985; Stirling, Calvert, and Spencer, 1987). Airborne vocalizations at reported frequencies between 10 Hz and 4 kHz (Kastelein, Postma, and Verboom, 1995; Miller, 1985; Miller and Boness, 1983; Verboom and Kastelein, 1995) accompany nearly every social interaction that occurs on land or ice (Charrier, Burlet, and Aubin, 2011; Insley, Phillips, and Charrier, 2003). These vocalizations facilitate kin recognition, male breeding displays, recognition of conspecifics, and female mate choice (Charrier Burlet, and Aubin, 2011; Insley, Phillips, and Charrier, 2003). Walruses also vocalize extensively while underwater at reported frequencies between 200 Hz and 4 kHz (Mouy et al., 2012; Ray and Watkins, 1975; Schevill, Watkins, and Ray, 1966; Stirling, Calvert, and Cleator, 1983; Stirling, Calvert, and Spencer, 1987). Base frequencies for most underwater walrus sounds occur at 400-1200 Hz (0.4-1.2 kHz) (Richardson et al., 1995). The purposes of underwater vocalizations are not explicitly known but are associated with breeding, swimming, and diving, and

may be used to locate the bottom and identify bottom substrates associated with prey (Mouy et al., 2012; Ray and Watkins, 1975; Sjare, Stirling, and Spencer, 2003; Stirling et al., 1987). Because of walrus grouping behavior, all vocal communications occur within a short distance (Miller, 1985). Walruses' underwater vocalizations are suspected to be detectable for only a few kilometers (Mouy et al., 2012) and likely do not act as long distance communication.

Presently, no walrus-specific hearing threshold criteria data exist; however, underwater audiograms for walruses show a strong similarity to those for otariids (Kastak et al., 2004, 2007 in Finneran and Jenkins, 2012). Therefore, for management and impact analysis purposes, the otariid functional hearing frequency ranges of 100 Hz to 35 kHz in-water and 100 Hz to 50 kHz in-air is often assumed for walruses (Finneran and Jenkins, 2012). The USFWS uses the NMFS otariid acoustic thresholds as an approximate surrogate for walruses (81 *FR* 52276; August 5, 2016). The U.S. Navy has assigned walruses to the 20 Hz to 60 kHz boxcar frequency range (a multi-species functional hearing range category used for their impact analyses) (Ciminello et al., 2012). A few psychophysiological studies have been conducted on both captive and free-ranging walruses (Kastelein et al., 1993a, 1996, 2002). These tests suggests in-air frequency sensitivity ranges from 0.25 kHz to 8 kHz with sensitivity down to 50 dB (re: 20 μ Pa) at 1 kHz to 4 kHz (Kastelein et al., 1993a, 1996). An in-water audiogram of an adult male Pacific walrus showed maximum frequency sensitivity at 12 kHz (at 67 dB re 1 μ Pa) (Kastelein et al., 2002). In-water sensitivity fell gradually below frequencies of <1 kHz and dropped off sharply above 12 kHz. The small number of test subjects (1 in Kastelein et al., 1993a and Kastelein et al., 2002, and 5 in Kastelein et al., 1996), incomplete data sets, and variable results among individuals (e.g., Kastelein et al., 1993a) preclude confident conclusions about walrus auditory thresholds. It is generally acknowledged that walruses are relatively sensitive to low frequency sound (less than 1 kHz) (Kastelein et al., 2002).

Somatic. Walrus' sense of touch (i.e., mechanosensory system) has been of scientific interest because they disturb large volumes of seafloor sediments while foraging, resulting in turbid waters where visibility is greatly reduced (Ray et al., 2006). Instead of vision, walruses use their whiskers (i.e., vibrissae) to find prey items. Walrus' vibrissae have evolved to be highly-sensitive (individuals can identify 3-mm thick objects down to a survey area of 0.4 cm²) (Kastelein and van Gaalen, 1988; Kastelein, Stevens, and Mosterd, 1990). The majority of research on walrus sensory systems has focused on hearing and touch; information from anatomical and behavioral studies provides insight into the walrus visual system but little is known about the olfactory and gustation (i.e., taste) systems (Dehnhart, 2002).

Vision

Concurrently, the walrus eye, while well-developed, is smaller than that of other pinnipeds and walrus visual acuity is thought to be lower than in phocids and otariids (Kastelein et al., 1993b).

Olfaction

Historical anatomical descriptions suggest that, compared with most terrestrial mammals, the olfactory system in pinnipeds, including walrus, is somewhat reduced (Lowell and Flanigan, 1980). However, traditional knowledge from subsistence communities and historical whaling accounts indicate that Pacific walruses are sensitive to smells and may flush from land and ice in response to odors indicative of a possible threat, such as exhaust from outboard engines of hunting vessels (Ellis, 2009; Huntington, Nelson, and Quakenbush, 2012; Huntington and Quakenbush, 2013).

Population and Status

Walruses in the North Pacific Ocean and U.S. portion of the Arctic Ocean belong to the Pacific subspecies. Pacific walruses are common in the Bering and Chukchi Seas, with seasonal variation in distribution (Fay, 1982; Garlich-Miller et al., 2011).

On February 8, 2008, the USFWS was petitioned to list the Pacific walrus as threatened or endangered under the ESA due to climate-change-induced loss of sea ice habitat and potential effects on prey from ocean warming and ocean acidification (74 *FR* 26548; September 10, 2009). On February 10, 2011, the USFWS completed a status review of the Pacific walrus and determined that although listing the species as endangered or threatened was warranted, the listing was precluded by other higher priority actions (76 *FR* 7634 February 10, 2011). The Pacific walrus is currently a candidate species under the ESA. A final decision as to whether to designate the species as threatened or endangered under the ESA is expected in 2017.

The size of the Pacific walrus population has never been known with certainty (USFWS, 2014). The population size has fluctuated markedly in response to varying levels of human exploitation (Fay, Kelly, and Sease, 1989; Fay et al., 1997; Taylor and Udevitz, 2015). Research suggests that a decrease in hunting pressure allowed for rapid population growth in the 1960s (Fay, Kelly, and Sease, 1989). By the late 1970s to earlier 1980s the Pacific walrus stock likely reached or exceeded carrying capacity and limitations in food availability resulted in a population decline (Fay, Kelly, and Sease, 1989; Taylor and Udevitz, 2015). Cow-calf ratios were substantially lower in the 1980s than in the 1960s, suggesting that reproductive rate (number of female calves per reproductive female) and calf survival rates declined, leading to an aging population (Citta, Quakenbush and Taras, 2014). Recent modeling of available data suggests that by the 1990s both reproductive rates and calf survival began to increase steadily but remained lower than estimated maximums for the period prior to the 1980s decline (Taylor and Udevitz, 2015). Model results suggest that overall population growth rate also increased and then moderated, rising from 0.94 in 1985 to 0.97 in 1999 to 1.00 in 2006 (the most recent year for which data were available for analysis) (Taylor and Udevitz, 2015). Survey efforts have been hampered by large confidence intervals, unknown bias and variation in data collection methods that prevent confident comparisons among surveys (Gilbert, 1989; Gilbert et al., 1992). Attempts to estimate population size have been further compromised because large portions of the population may be in the water at any given time and because walruses tend to aggregate in large, closely-packed groups, both factors that make accurate counts difficult (Garlich-Miller and Jay, 2000; USFWS, 2014). The most recent population survey of Pacific walruses was conducted in 2006. Due to weather constraints, approximately 50% of the available walrus habitat was surveyed. The final population estimate of 129,000, with a range of 55,000-550,000 (Speckman et al., 2011) represents a minimum population estimate since it was not possible to extrapolate from the area surveyed to the entire habitat area.

Distribution

The USFWS considers Pacific walrus to be extralimital to the Proposed Action Area.

The Pacific walrus ranges from the Bering Sea to the Chukchi Sea, occasionally ranging into the East Siberian and Beaufort Seas. Walruses are social and gregarious animals. They tend to travel and haul out to rest on ice or land in densely packed groups. Group size can range from a few individuals up to several thousand animals (Gilbert, 1999; Kastelein, 2002; Jefferson, Webber, and Pitman, 2008). Pacific walrus distribution generally varies with the extent and distribution of sea ice, although localized areas of walrus activities may occur independent of the movement of ice floes (Garlich-Miller et al., 2011; Jay et al., 2010; Jay et al., 2014; Sacco, 2015).

Walruses are migratory; most animals move south into the Bering Sea with the advancing ice in autumn and north as the ice recedes in spring (Fay, 1981, 1982; Huntington, Nelson, and Quakenbush, 2012). The spring migration usually begins in April, with most walruses moving north through the Bering Strait by late June (Fay, 1982; Fay et al., 1984; Garlich-Miller et al., 2011; Jay, Fischbach, and Kochnev, 2012; Kochnev, 2006). In the summer, most of the females and juveniles move to either the western Chukchi Sea near the Wrangel and Herald Islands, or the eastern Chukchi Sea near Hanna Shoal, and several thousand (primarily adult males) aggregate and remain in the Gulf

of Anadyr and in Bristol Bay (Fay, 1982; Fay et al., 1984; Garlich-Miller et al., 2011; Jay, Fischbach, and Kochnev, 2012; Kochnev, 2004, 2006; Zdor, Zdor, and Ainana, 2010). Limited numbers of walrus inhabit the Beaufort Sea during the open water season, and they are considered rare east of Point Barrow (Sease and Chapman, 1988).

Pacific walrus summering on the Russian side of the Chukchi Sea have historically used terrestrial haulouts on the Chukotka peninsula (Fay, 1982; Fay et al., 1984; Jay, Fischbach, and Kochnev, 2012; Kochnev et al., 2004, 2006; Robards and Garlich-Miller, 2013; Zdor, Zdor, and Ainana, 2010). Small haulouts have also historically occurred along the U.S. Chukchi Sea coast (Robards and Garlich-Miller, 2013). No terrestrial haulout sites occur in the Beaufort Sea.

Most walrus sightings in the Beaufort Sea are west of Cape Halkett (Clarke et al., 2013; Goetz, Rugh, and Mocklin, 2007, 2009; LGL, JASCO, and Greenridge, 2013; Ljungblad, et al., 1987, 1988; Treacy, 1993, 2000) but walrus have been observed as far east as Kaktovik and the Canadian border (Funk et al., 2010; LGL, JASCO, and Greenridge, 2013). Walrus in the Beaufort Sea are most frequently found near the southern margins of the pack ice, although in recent years of reduced ice cover, the majority of individuals reported by industry monitoring have been more than 15 kilometers (9 miles) from the edge of the main pack ice in waters less than 50 meters deep (Funk et al., 2010; Jankowski, Patterson, and Savarese, 2009). Walrus have occasionally been documented in and near Beaufort Sea oil and gas infrastructure; walrus have hauled out on Northstar Island and Endicott Causeway and have been recorded in the waters around the Endicott and West Dock causeways (Streever and Bishop, 2014; USFWS, 2011).

Life History

Reproduction. Walrus have the lowest rate of reproduction of any pinniped species (Fay, 1982). Although male walrus reach puberty at 6-7 years of age, they are unlikely to successfully compete for females until they reach full body size at 15 years of age or older (Fay, 1982; Fay et al., 1984). Female walrus attain sexual maturity at 4-7 years of age (Fay, 1982; Garlich-Miller, Quakenbush, and Bromaghin, 2006).

Mating occurs primarily in January and February in broken pack-ice habitat in the Bering Sea. Breeding bulls follow herds of females and compete for access to groups of females hauled out onto sea-ice. Females typically give birth to a single calf in May the following year shortly before, or during, the spring migration (Fay, 1982). Mothers and newborn calves stay on ice floes until calves develop sufficient energy reserves for thermoregulation. The calf is closely attended by the cow, and typically nurses for 1-2 years (Fay, 1982). Ovulation may be suppressed until the calf is weaned, raising the birth interval to 3 years or more (Garlich-Miller and Stewart, 1999). The low birth rate of walrus is offset in part by considerable maternal investment in offspring (Fay et al., 1997).

Molt. Adult walrus have a short, sparse, tawny pelage, and molt annually during the summer months (June-August) (Fay, 1982).

Diet

Pacific walrus are considered benthic specialists but consume a wide variety of prey species. Stomachs of some walrus included over 60 benthic invertebrate genera (e.g., Bluhm and Gradinger, 2008; Fay et al., 1984; Sheffield and Grebmeier, 2009). Bivalves, gastropods, and polychaete worms are the dominant prey groups (Sheffield and Grebmeier, 2009). Male and female walrus consumed essentially the same prey types (Sheffield and Grebmeier, 2009; Seymour, Horstmann-Dehn, and Wooller, 2014b), despite seasonal sexual segregation in foraging areas during summer months (Fay, 1982; Garlich-Miller et al., 2011; Seymour, Horstmann-Dehn, and Wooller, 2014a, see also Distribution, above). Walrus will also consume other prey types, including seabirds and ice seals (Fay, 1960; Lowry and Fay, 1984; Fay, Feder, and Stoker, 1977; Fay, Sease, and Merrick, 1990; Seymour, Horstmann-Dehn, and Wooller, 2014a). This is hypothesized to occur opportunistically

although traditional knowledge suggests that some individuals preferentially pursue higher trophic level prey (Fay, 1960, 1982; Fay, Sease, and Merrick, 1990; Huntington, Nelson, and Quakenbush, 2012).

Mortality

The continuing loss of sea ice habitat and harvest levels are likely the biggest stressors on the Pacific walrus population (Jay, Marcot, and Douglas, 2011). Impacts to Pacific walruses from climate change are examined in depth in Section 4.3.4.2 of this DEIS.

Predation. Polar bears are known to prey on walrus calves, and killer whales (*Orcinus orca*) have been known to take all age classes of walruses (Frost, Russell, and Lowry, 1992; Garlich-Miller et al., 2011; Kryukova, Kruchenkova, and Ivanov, 2012; Melnikov and Zagrebin, 2005; Zdor, Zdor, and Ainana, 2010). Predation levels are thought to be highest near terrestrial haulout sites where large aggregations of walruses can be found; however, few observations exist for off-shore environments. USFWS currently does not consider predation to be a significant stressor on the Pacific walrus population (Garlich-Miller et al., 2011).

Harvest. Historically, Pacific walrus was hunted commercially throughout its range. Commercial harvest ceased in the U.S. in 1941 with the passage of the U.S. Department of Commerce regulation (1937) and the “Walrus Act” in 1941 (USFWS, 1994). Commercial harvest in Russia ended in 1991 as a result of economic collapse of the industry (Garlich-Miller and Pungowiki, 1999). Currently, walrus hunting in Alaska and Chukotka is restricted to subsistence harvest by indigenous peoples. Pacific walruses have been hunted by coastal Natives in Alaska and Chukotka for thousands of years. The USFWS, in partnership with the Eskimo Walrus Commission (EWC), the Association of Traditional Marine Mammal Hunters of Chukotka, and the Qayassiq Walrus Commission, administered subsistence harvest monitoring programs in Alaska and Chukotka in 2006–2010. Harvest mortality over this timeframe is estimated at 3,828 to 6,119 walruses per year (USFWS, 2014). This mortality estimate includes corrections for underreported harvest and struck and lost animals.

Injury. Disturbance events can cause walruses to stampede into the water and have been known to result in abortions, injuries and mortalities (Garlich-Miller et al., 2011; Fischbach, Monson, and Jay, 2009; USFWS, 2014). The risk of stampede-related injuries increases with the number of animals hauled out. Calves and young animals at the perimeter of these herds are particularly vulnerable to trampling injuries (Fischbach, Monson, and Jay, 2009; Udevitz et al., 2013). Injuries can also result from tusk strikes, which are common in both sexes and all age-classes but are most prevalent on males during the breeding season (USFWS, 2015c).

Alaska Native hunters from St. Lawrence Island have described walruses becoming emaciated after becoming entrapped in heavy ice. It is probable that in some instances those walruses starve to death but no western science documentation of such events exists (USFWS, 2015c). Rock slides are a hazard to walruses on terrestrial haulouts and occasionally result in mortality (USFWS, 2015c). They have also tumbled down steep slopes and fallen off cliffs at some haulouts (USFWS, 2015c).

Injuries and mortalities from fisheries interactions appear to be rare; the mean number of observed mortalities during 2006-2010 was one walrus per year (with a range of 0-3 individuals) (USFWS, 2014). The USFWS considers commercial fisheries related mortality to be insignificant because it is less than 1% of PBR (USFWS, 2014).

Climate Change

Most Pacific walruses remain in the Chukchi and Bering seas throughout their life. Only a few individuals or small groups move into the Beaufort Sea during summer months. For this reason the direct and indirect effects of climate change in the Beaufort Sea and the Proposed Action Area are

unlikely to have much of a numerical effect on the Pacific walrus population. With increasing sea ice losses, more walrus terrestrial haulouts are likely to develop at points along the coastline of Alaska and Russia. The increased use of coastal haulouts introduces risks, such as predation by polar bears, stampedes that crush individual walruses, and increased harassment from people. As the Pacific walrus population becomes increasingly dependent on coastal habitats, interactions with humans would likely increase as well.

Climate change may affect the Pacific walrus population by altering their distribution and possibly increasing their presence in the Beaufort Sea. By the late 21st century areas with favorable ice conditions for breeding and calving would likely shift north, and the as projected losses of sea ice during summer becomes more pronounced walrus reliance on coastal haulouts would probably increase (Garlich-Miller et al., 2011). Such shifts in habitat use patterns could result in increased mortalities from disturbances and a reduced prey base near coastal haulouts. Ocean acidification could also act to reduce the prey base for walruses throughout the Arctic, depending on the severity of the changes. In addition, the spread of disease and parasites as a result of climate change through sea ice loss has also been suggested as a potential threat to Arctic marine mammals, including Pacific walruses, by emigration/immigration events, but the true potential for the spread of pathogens to Pacific walruses from various vectors is inconclusive, and, while these factors are expected to eventually result in a population decline, the timeframe and magnitude remains speculative.

3.2.4.4. Polar Bear

In-depth descriptions of the status, distribution, life history, and survival of the polar bear populations occurring in U.S. waters (in the Chukchi and Beaufort seas) are provided in the USFWS Range-Wide Status Review of the Polar Bear (*Ursus maritimus*) (Schliebe et al., 2006) the Polar Bear (*Ursus maritimus*) 5-Year Review: Summary and Evaluation (USFWS 2017), and Biological Opinions (USFWS, 2011, pages 20-23, 24-27; USFWS, 2012, pages 46-49 and 66-71; USFWS, 2013, pages 15-18 and 27-32; USFWS, 2015a, Sections 3.3.3, 4.4.5). The following text summarizes pertinent information from the aforementioned documents, which are incorporated by reference, and includes new scientific information when available.

Sound

Polar bears communicate through their body language, vocalizations, and scent markings (Owen et al., 2015; Stirling and Derocher, 1990; USFWS, 2013; Wemmer, Von Ebers, and Scow, 1976). With regards to hearing, one way young cubs (approximately 4-5 months old) can communicate with female bears is by humming (Derocher, Van Parijs, and Wiig, 2010; Peters, Owen, and Rogers, 2007). The purpose of this vocalization is hypothesized to stimulate milk release from lactating female bears (Peters, Owens, and Rogers, 2007). Hearing is also vital for successful prey capture. Although polar bears primarily use their sense of smell while hunting, their hearing becomes essential during the latter stages of hunting because at close distances sound propagates more rapidly than scent (Cushing, Cushing, and Jonkel, 1988).

Presently, no hearing threshold criteria specific to polar bears exist. For management and impact analysis purposes the otariid in-air functional hearing range of 100 Hz to 35 kHz is often used for polar bears because of the anatomical similarities between the otariid ear and that of other carnivores (Finneran and Jenkins, 2012). The U.S. Navy has assigned polar bears to the 20 Hz to 60 kHz boxcar frequency range (a multi-species functional hearing range category used in their impact analyses) (Ciminello et al., 2012). Research focused on collecting data that could be used to develop threshold criteria is ongoing. Nachtigall et al. (2007) used electrophysiological method to measure the in-air hearing abilities of three anesthetized polar bears and found that the best sensitivity occurred in the frequency range from 11.2-22.5 kHz.

Recently, Owen and Bowles (2011) used behavioral procedures to measure the in-air auditory thresholds and hearing sensitivity of five female polar bears at frequencies between 125 Hz and 31.5 kHz. Results showed that the greatest sensitivity occurred between 8 and 14 kHz. Sensitivity declined sharply between 14 and 20 kHz, suggesting an upper hearing range 10-20 kHz lower than small terrestrial carnivores (Bowles et al., 2008; Fay, 1988 in Owen and Bowles, 2011).

Vision

In addition to hearing, and olfaction, polar bears have well-developed vision, akin to that of other bear species that aids in detection and capture of prey (Stirling, 1974 in Dehnhardt, 2002).

Olfaction

Polar bears have a highly developed olfactory system that allows them to locate subnivean seal lairs when foraging (Stirling, 1988) and detect scent markings left in the tracks of other bears (Owen et al., 2015).

Population and Status

Of 19 formally recognized subpopulations (stocks) of polar bears, individuals from two stocks occur in the U.S. Beaufort Sea. On May 15, 2008, the USFWS listed the polar bear as threatened throughout its range (73 *FR* 28212, May 15, 2008). Consequently, the species has been designated a depleted species under the MMPA (i.e., the species is below its optimum sustainable population level) (16 USC 1362(1)(c)). The polar bear was listed as threatened largely due to the ongoing and projected loss of sea ice habitat caused by climate change (73 *FR* 28212, May 15, 2008) and the USGS has predicted that without changes in the rate of sea-ice loss, polar bear habitat in Alaska will decline by 60-80% by the end of the 21st century (Durner et al., 2009). On December 7, 2010, USFWS published the final rule designating Critical Habitat in the Federal Register (75 *FR* 76086). The final rule identifies geographic areas containing features considered essential for the conservation of the polar bear. The USFWS identified three areas or units as critical habitat that requires special management or protection: barrier island habitat, sea ice habitat and terrestrial denning habitat. Barrier island habitat includes coastal barrier islands and spits along Alaska's coast. It is used for denning, refuge from human disturbance, access to maternal dens and feeding habitat, and travel along the coast. Sea ice habitat is located over the continental shelf and includes water 300 meters (~984 ft) or less in depth. Terrestrial denning habitat includes lands within 32 kilometers (~20 mi) of the northern coast of Alaska between the Canadian border and the Kavik River and within 8 kilometers (~5 mi) and Utqiaqvik, (formerly Barrow). Polar bears and their designated critical habitat are protected from significant impacts caused by industrial activities through the BOEM leasing stipulations and required operating procedures, as well as subsequent MMPA incidental and directed take authorizations, and ESA consultations.

The most recent estimate for the SBS stock is 900 (90% C.I. 606–1,212; C.V. = 0.106) (Bromaghin et al., 2015), which is based on open population capture-recapture data collected from 2001 to 2006. The SBS stock likely was overharvested prior to the passage of the MMPA in 1972 (Amstrup, Stirling, and Lentfer, 1986) but the population generally increased from 1972 through the late 1990s (Amstrup, McDonald, and Stirling, 2001). Estimates by Regehr, Amstrup and Stirling (2006) suggest that by the mid-2000s the SBS population had stabilized and possibly declined. Recent analysis of data from 2001-2010 indicated that the SBS stock experienced a 25-50% decline in abundance from 2004 through 2006, likely due to poor foraging conditions and/or lack of prey (Bromaghin et al., 2015; Stirling et al., 2008). The overall survival rate of adults and young stabilized from 2008 to 2010, although survival rates of sub-adult bears continued to decline, likely a residual effect of the poor nutritional conditions in previous years (Bromaghin et al., 2015).

The most recent estimate of the CBS stock is 2,000 bears (Aars, Lunn, and Derocher, 2006; Lunn et al., 2002). This figure is based on extrapolations from older den survey data from Wrangel Island,

Russia. The estimate has wide confidence intervals and is not sufficient to evaluate status or trends (IUCN, 2006). Observations of low cub production and maternal denning on Wrangel Island in 2004-2013 suggest concern for reductions in natural population growth of the CBS stock (Ovsyanikov, 2012 in IUCN, 2014a). Concurrently, U.S. capture-recapture research conducted in spring 2008-2011 indicated that CBS animals have good body condition and reproduction, suggesting capacity for positive population growth despite sea ice loss (Rode et al., 2014). Furthermore, human-caused removals, particularly illegal harvest in Russia, are thought to be significantly lower than in the late 1990's (IUCN, 2014a).

Distribution

Although they are classified as marine mammals and are strong swimmers, polar bears rely principally on sea ice to provide a substrate on which to roam, hunt, breed, den, and rest. They also use terrestrial islands and coastal mainland habitats. Preferred habitats include both the active seasonal ice zone that overlies the continental shelf and associated islands, and areas of heavy offshore pack ice (Derocher et al., 2013; Durner et al., 2004, 2009; Schliebe et al., 2006). Bears often travel great distances in search of prey and require large home ranges in order to meet foraging requirements (Auger-Méthé, Lewis, and Derocher, 2015; Derocher et al., 2013). Some bears may be observed swimming between offshore ice and the shoreline or barrier islands (Derocher et al., 2013; Durner et al., 2011; Pagano et al., 2012).

The SBS stock is predominantly distributed throughout the Beaufort Sea off of the northern coast of Alaska. The CBS stock is distributed throughout the Chukchi and Bering seas off of northwestern Alaska, although bears from the CBS stock could be encountered in the Beaufort Sea because the distribution of the two stocks overlap at their boundaries in the western Beaufort Sea and eastern Chukchi Sea (USFWS, 2010a, 2010b).

The original eastern boundary of the SBS stock, shared by the U.S. and Canada, occurred south of Banks Island and just east of the Baillie Islands, Canada (Amstrup et al., 2000). However, a new eastern boundary, moved westward near the community of Tuktoyaktuk, Northwest Territories, Canada (WMAC, 2011), is currently being implemented by the agencies that manage the stock (USFWS, 2016). The western boundary for the SBS stock is near Icy Cape, Alaska (Amstrup et al., 2004, Obbard et al., 2010).

The CBS stock is managed by the U.S. and the Russian Federation and this stock's boundaries are currently described differently by management and scientific organizations. The Agreement between the United States of America and the Russian Federation on the Conservation and Management of the Alaska-Chukotka Polar Bear Population describes the western boundary as the mouth of the Kolyma River, Russia and its eastern boundary as a line extending north from Point Barrow, Alaska (Obbard et al., 2010 in USFWS, 2016). The Polar Bear Specialist Group describes the northwestern boundary as Chauniskaya Bay, in the East Siberian Sea, while the northeastern boundary is near Icy Cape, Alaska (Obbard et al., 2010; USFWS, 2016).

The southern distribution of the CBS stock is determined by the southern edge of the pack ice (Garner, Knick, and Douglas, 1990). The polar bear stocks are further classified as occurring in one of four ecoregions (Amstrup et al., 2008). Both the CBS and SBS stocks belong to the Divergent Ice Ecoregion which is characterized by the formation of annual sea ice that is transported towards the polar basin.

During the open-water season the SBS population occurs more commonly along the coast and barrier islands of the Beaufort Sea while the CBS population occurs mainly on Wrangel and Herald Islands and along the Chukotka (and to a lesser extent the U.S. Chukchi) coast (Derocher et al., 2013; Kalxdorff et al., 2002; Kochnev, 2006; Kochnev et al., 2003; Ovsyanikov, 1998, 2003; Rode et al., 2015; Stishov, 1991).

During the winter and spring, polar bears tend to concentrate in areas of ice with pressure ridges, at floe edges, and on drifting seasonal ice at least 8 inches thick (Schliebe et al., 2006). In the winter, the use of shallow-water areas is greatest in areas of active ice with shear zones and leads (Durner et al., 2004; Wilson et al., 2014). The use of landfast ice increases in the spring, during the pupping season of ringed seals, and multiyear ice is used in late summer and early autumn, as the pack ice retreats to its minimal extent (Derocher et al., 2013; Durner et al., 2004). Ringed seal pupping habitat is especially important to females with cubs of the year because they preferentially select this habitat to replenish their fat reserves immediately after they emerge from maternal dens (Derocher et al., 2013; Stirling and Lunn, 1997; Stirling et al., 1993). Adult males usually remain with multiyear ice during late summer and early fall and rarely come ashore (Schliebe et al., 2006). SBS polar bears begin to appear on the mainland and barrier islands in increasing numbers during the open-water period in August when the pack ice can be very far from shore (Miller, Schliebe, and Proffitt, 2006; Schliebe et al., 2008). Recent surveys (2010-2013) along the Alaska Beaufort Sea coast during August through October have documented an average of 9 ± 2 bears/100 kilometers (Atwood et al., 2015).

Prior to freeze-up in fall, large aggregations of polar bears may form at subsistence-harvested bowhead whale carcass sites called, bone piles, at Point Barrow, Barter Island and Cross Island (Atwood et al., 2015; Miller, Schliebe, and Proffitt, 2006; Miller, Wilder, and Wilson, 2015). Atwood et al. (2015) calculated that, after carcasses were added to the bone piles, 78% of all polar bears observed during their aerial surveys were within 16 kilometers of the pile. The greatest percentage of bears was documented near Barter Island (40%), followed by Cross Island (33%). With the return of sea ice in the fall, polar bears become more widely dispersed across the sea ice. This dispersal is not even; SBS bear concentrate on ice in shallow waters less than 300 meters deep over the continental shelf and in areas with >50% ice cover (Durner et al., 2004, 2006, 2009; Stirling, Lunn, and Iacozza, 1999). Meanwhile, CBS individuals range south through the Bering Strait (Schliebe et al., 2006; USFWS, 2010a; Voorhees and Sparks, 2012; Wilson et al., 2014).

Maternal dens are commonly located on pack ice in snow banks near pressure ridges or on land in compacted snow drifts adjacent to coastal banks (barrier islands and mainland bluffs), river or stream banks (Durner, Amstrup, and Ambrosius, 2001, 2006; Durner, Amstrup, and Fischbach, 2003; Durner, Simac, and Amstrup, 2013; Stirling and Andriashek, 1992). Dens are often also located at the edge of stable sea ice on the inshore side of barrier islands, although an increasing number of SBS bears are denning on land (Fischbach, Amstrup, and Douglas, 2007). The main terrestrial denning areas for the Southern Beaufort Sea population in Alaska occur on the barrier islands from Point Barrow to Kaktovik and along coastal areas up to 25 miles inland including the Arctic National Wildlife Refuge to Peard Bay, west of Point Barrow (Amstrup and Gardner, 1994; Amstrup, 2000; Durner, Amstrup, and Ambrosius, 2001, 2006). Approximately 63% of pregnant SBS bears rely on terrestrial habitat for maternal denning (Amstrup and Gardner, 1994; Fischbach, Amstrup, and Douglas, 2007). Denning of bears from the CBS stock occurs primarily on Wrangel and Herald Islands, and on the Chukotka coast in the Russian Federation. Though maternal denning habitat is found on the western coast of Alaska, denning on land for the U.S. portion of the CBS stock is not common (78 *FR* 35364, June 12, 2013). Female polar bears do not show fidelity to specific den locations, but they tend to den on the same type of substrate, either pack ice or land, from year to year and may return to the same general area to den (Amstrup and Gardner, 1994; Schliebe et al., 2006; Fischbach, Amstrup, and Douglas, 2007). The USGS Alaska Science Center maintains a catalogue of known polar bear den locations, including records from USGS and USFWS surveys, other research activities, and anecdotal reports from other government agencies, coastal residents, and industry personnel (Durner et al., 2010). Figure 3.2.4-15 shows locations of known polar bear dens in the vicinity of the Liberty Development.

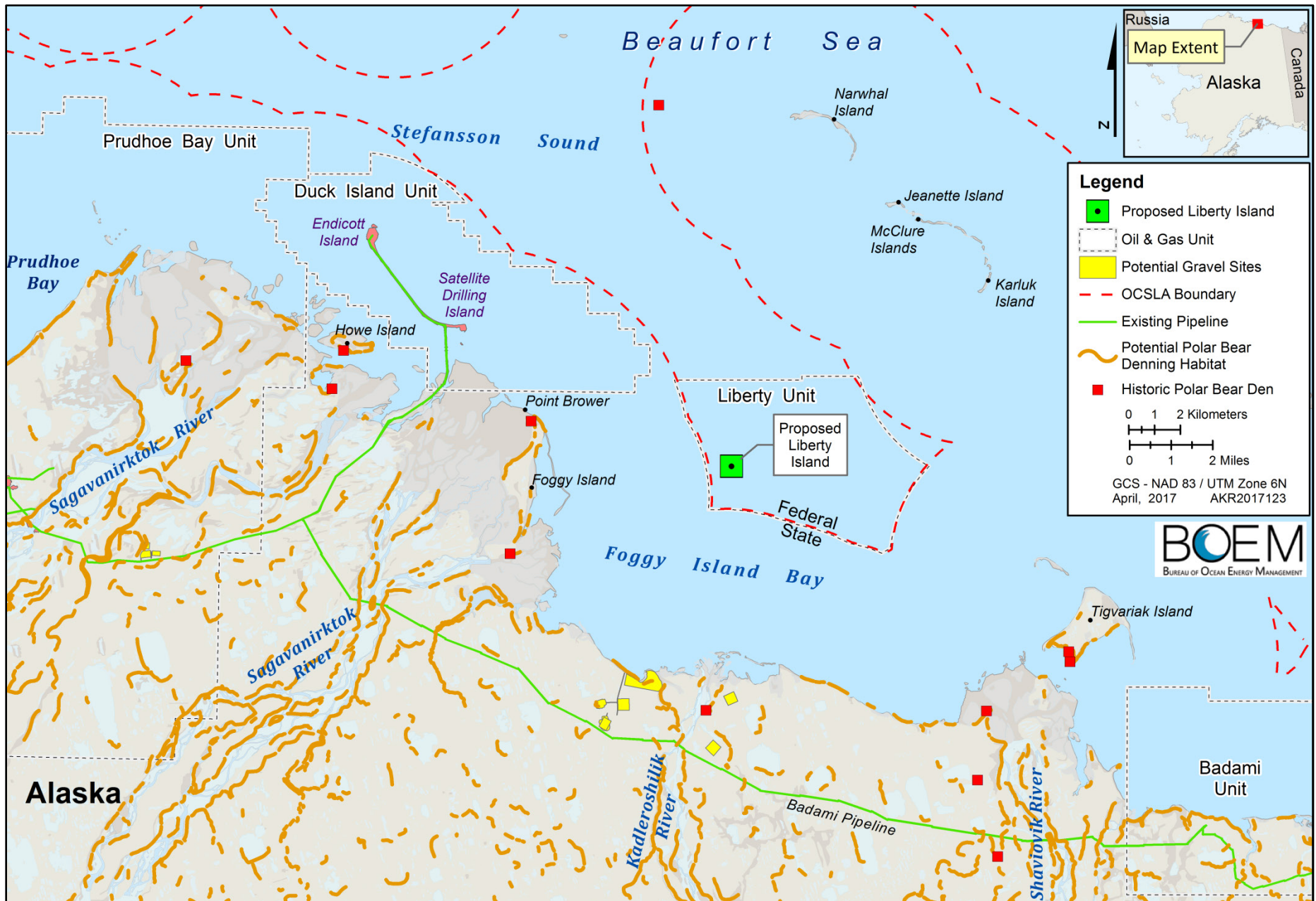

Figure 3.2.4-15. Polar Bear Maternal Den Sites and Potential Maternal Denning Habitat.

The USFWS designated critical habitat for the polar bear (75 *FR* 76086) on December 7, 2010. The U.S. District Court for the District of Alaska issued a decision to the Service on January 11, 2013, which vacated and remanded the final rule on polar bear critical habitat in Alaska Oil and Gas Association et al. v. Salazar et al. (D. Alaska) (3:11-cv-00025-RRB). On February 29, 2016, the Ninth Circuit Court of Appeals upheld the final polar bear critical habitat rule on all points. The critical habitat includes barrier island habitat and sea ice habitat (both described in geographic terms), and terrestrial denning habitat (a functional determination). Barrier island habitat consists of coastal barrier islands and spits along Alaska's coast, and is used for denning, refuge from human disturbance, and travel to mainland maternal denning habitat and offshore maternal denning and foraging habitats. Sea ice habitat is located over the continental shelf, and includes water 300 meters (~984 ft) or less in depth. Terrestrial denning habitat includes lands within 32 kilometers (~20 mi) of the northern coast of Alaska between the Canadian border and the Kavik River, and within 8 kilometers (~5 mi) between the Kavik River and Point Barrow (75 *FR* 76086).

Polar bears are expected to use the Proposed Action Area. In the ice-covered season pregnant females could use the surrounding coastal areas for maternal denning. Non-denning bears (males and females) could use the area to hunt and as a travel corridor. In the open-water season most bears in the Proposed Action Area will be found on the barrier islands or the coastline. During long-term ecological monitoring by BPXA between 2000 and 2013, the mean number of bear sightings reported annually (excluding repeat reports) for the Endicott Satellite Drilling Island and Liberty Unit was 42, but varied from 8 to 158 reports per year (Streever and Bishop, 2014). The number of sightings reported annually was influenced by the number of personnel present, and type and duration of activity conducted in a given year. As such, direct comparison among years is not possible; however, across all of its oil fields BPXA has identified a general upward trend in the number of annual sightings of polar bears on land (Streever and Bishop, 2014). The highest concentration of polar bears near the Proposed Action Area occurs on land during the open water period, when some polar bears enter the coastal environment as they abandon melting sea ice to search for food on/near land (e.g., whale carcasses), or search for suitable den sites (pregnant females). Aerts et al. (2008) recorded 9 sightings of a total of 10 polar bears in Foggy Island Bay during open-water seismic surveys (July 15 to August 25, 2008). More polar bears were observed on ice or land (60%) than swimming in the water (40%) (Aerts et al., 2008). During spring 2013 geotechnical investigations in Foggy Island Bay conducted for the Proposed Action, the tracks of one adult bear and one sow-cub pair were reported; however, no polar bears were sighted in the Proposed Action Area during the 2013 winter geotechnical investigations, nor were any seen during 2013 annual monitoring of the Proposed Action Area conducted by BPXA (BPXA, 2013a, 2013b). No polar bears were observed during the 2014 Liberty open-water season geohazard and seafloor mapping surveys (Smultea et al., 2014).

Life History

Survival. Polar bears are long-lived mammals and in large part are not known to be susceptible to disease, parasites, or injury. The oldest known female polar bear in the wild was 32 years of age and the oldest known male was 28, though few polar bears in the wild live to be older than 20 (Stirling, 1990). Survival rates vary by age class and increase with age up to approximately 20 years of age (Schliebe et al., 2006). Polar bears are well adapted for thermoregulation in the Arctic, using a fat layer, insulative fur, and specialized hide to maintain a core temperature that is comparable to mammals found in temperate climates (Stirling, 1988).

Reproduction. Polar bears are characterized by a late age of sexual maturity, small litter sizes, and extended parental investment in raising young, factors that combine to contribute to a very low reproductive rate (Schliebe et al., 2006). Reproduction in the female polar bear is similar to that in other ursids. They enter a prolonged estrus between March and June, when breeding occurs (Schliebe et al., 2006; Stirling, Spencer, and Andriashek, 2016). The peak of breeding season appears to be from early April through mid-May. Observations and bloodwork analyses indicate that during the

breeding period mating pairs as well as reproductively-mature but unpaired males spend very little time hunting, although in mating pairs the female spend a significantly greater proportion of time hunting than did the male (Stirling, Spencer, and Andriashek, 2016). Implantation of the embryo is delayed; the timing is linked to daylength in autumn (Lønø, 1970 in Stirling, Spencer, and Andriashek, 2016). Total gestation is 195–265 days (Uspenski, 1977 in Schliebe et al., 2006), although during most of this time, active development of the fetus is suspended. The timing of implantation, and therefore the timing of birth, is likely dependent on body condition of the female, which depends on a variety of environmental factors, including availability of seal prey (Schliebe et al., 2006). Bears in the Beaufort Sea usually reach reproductive maturity at 5 years old (Lentfer and Hensel, 1980; Stirling, Pearson, and Bunnell, 1976).

Polar bears typically enter dens in the fall, give birth, and remain in or near their dens until they leave with their cubs in March or April. Only pregnant females den for an extended period during the winter; other polar bears may excavate temporary dens to escape harsh winter conditions, but otherwise remain active year-round (Amstrup, 2003). Some pregnant females construct and enter natal dens in October, but most do so in mid- to late November (Amstrup and Gardner, 1994). Birth occurs typically in late December or early January, and mothers and cubs emerge from natal dens in late March or April (Amstrup and Gardner, 1994; Amstrup, 2000; Smith et al., 2007). Researchers monitored den emergence and abandonment along the Beaufort Sea coast in or near the Prudhoe Bay area from 2000-2013 (Streever and Bishop, 2014). On average, over the 13 years of this study, female bears emerged from their dens on March 16 (SD = ± 8.8 days) and stayed at den sites until March 23 (SD = ± 9 days). After this initial emergence, bear families remained at the den site for periods ranging from 1 to 18 days, with an average stay of 6.5 days (Streever and Bishop, 2014)

Litter size and litter production rate vary by geographic area and are expected to change with population size relative to carrying capacity (Schliebe et al., 2006). Furthermore, litter size may change in response to hunting pressure, environmental factors and other population perturbations. Litters of two cubs are most common (Schliebe et al., 2006). Litters of three cubs are seen sporadically across the Arctic (Ramsay and Stirling, 1988; Derocher and Stirling, 1992). The average litter size encountered during multiple studies throughout the range of polar bears varies from 1.4 to 1.8 cubs (Schliebe et al., 2006). Newborn polar bears weigh approximately 0.6 kg (1.3 lbs) (Blix and Lentfer, 1979) and are completely dependent on their mother for survival. Cubs grow rapidly, and may weigh 10–12 kg (22-26.4 lbs) by the time they emerge from the den in the spring. Survival of cubs is dependent on their weight when they exit dens (Derocher and Stirling, 1992). Most cub mortality occurred early in the period after emergence from the den (Amstrup and Durner, 1995; Derocher and Stirling, 1996). Young bears will stay with their mothers until weaning, which occurs most commonly in early spring when the cubs are 2.3 years of age (Schliebe et al., 2006). Female polar bears are available to breed again after their cubs are weaned. Therefore, in most areas, the minimum successful reproductive interval for polar bears is 3 years.

Diet

Polar bears are upper level predators in the Arctic marine ecosystem, preying primarily on ringed seals, and to a lesser extent on bearded and spotted seals (Pilford, 2014; Rogers et al., 2015; Schliebe et al., 2008; Smith, 1980; Allen and Angliss, 2013). They will also capture and consume larger prey such as walruses, belugas, caribou, and narwhals (Derocher, Andriashek, and Stirling, 1993; Gaston and Elliott, 2013; Rode et al., 2015; Stempniewicz, 1993) and will opportunistically forage on birds, eggs, and coastal plants (Derocher, Andriashek, and Stirling, 1993; Gaston and Elliott, 2013; Rode et al., 2015; Stempniewicz, 1993). Carrion, most notably the remains of subsistence-harvested bowhead whales at bone piles at Barter Island, Cross Island, and Point Barrow, are an increasingly important food source, particularly for SBS polar bears (Herreman and Peacock, 2013; Koski et al., 2005; Miller, Schliebe, and Proffitt, 2006; Miller, Wilder, and Wilson, 2015; Rogers et al., 2015). The use of whale carcasses as a food source likely varies among individuals and years. Stable isotope analysis

of polar bears in 2003 and 2004 suggested that bowhead whale carcasses comprised 11%-26% (95% CI) of the diets of sampled polar bears in 2003, and 0%-14% (95% CI) in 2004 (Bentzen et al., 2007). More recently, stable isotope analysis and telemetry data suggest an emerging alternate foraging strategy among SBS adult female polar bears: a subset of bears remained in close proximity to the coast and relied heavily on bowhead whale carcasses while the other portion continued to follow a more traditional strategy, foraging widely on the sea ice for ringed and bearded seals (Rogers et al., 2015). With anticipated continued declines in summer sea ice habitat and potential adverse consequences to ringed seal populations, polar bear reliance on bowhead whale bone piles may increase (Miller, Wilder, and Wilson, 2015; Overland and Wang, 2013).

Mortality

The primary threat to polar bears is loss of its sea-ice habitat, driven by global climate change (Atwood et al., 2015a; Bromaghin et al., 2015; Hunter et al., 2010; Pilford et al., 2015; Regehr et al., 2010, 2015; Rode, Amstrup, and Regehr, 2010; Rode et al., 2014; USFWS, 2016). Impacts to polar bears from climate change are examined in depth in Section 4.3.4.6 of this DEIS. Other sources of mortality are discussed below.

Predation. In general, polar bears have no natural non-human predators; however, cannibalism by adult males on cubs and occasionally on adult bears is known to occur (Amstrup et al., 2006; Derocher and Wiig, 1999; Stirling and Ross, 2011; Taylor, Larsen, and Schweinsburg, 1985). While grizzly bears are increasingly common at bone piles in the Beaufort Sea and recent observations at these bone piles indicate that grizzlies are socially dominant, this dominance is asserted without aggression and intraspecies predation at these aggregations have not been recorded in the U.S. Beaufort Sea (Miller, Wilder, and Wilson, 2015).

Harvest. Historically, polar bears have been harvested for subsistence, handicrafts, and recreational hunting. Since the enactment of the MMPA in 1972, polar bear harvest is only allowed for Alaska Native hunters living in coastal communities. This exception allows for the taking of polar bears for subsistence and making of handicrafts provided that the harvest is not conducted in a wasteful manner. The annual harvest from the SBS population was 39/year in the 1980s, 33/year in the 1990s, and 32/year in the 2000s (USFWS, 2010b). More recently for the 10-year period of 2006-2015, an average of 19 bears/year were removed from the U.S. portion of the SBS stock (USFWS 2017). The annual harvest from the CBS stock was 92/year in the 1980s, 49/ year in the 1990s, and 43/year in the 2000s (USFWS, 2010a). From 2006-2015, an average of 30 bears/ year were removed from the U.S. portion of the CBS stock which was estimated relative to the boundary near Icy Cape, Alaska, as recognized by the PBSG (Obbard et al., 2010). From 2010 to 2011 the annual illegal harvest was estimated at 32 bears/year in Russia, although harvest in Russia is hard to record and quantify) (Kochnev and Zdor, 2015). Current removal levels for the CBS are thought to be significantly lower than in the late 1990s (IUCN, 2014a). The USFWS has determined that human-caused removals, including subsistence harvest and lethal take for the protection of human life and property, are not a threat to the persistence or recovery of SBS and CBS polar bears as long as removal occurs at a sustainable rate that has only a small or negligible effect on the persistence of the populations (Atwood et al., 2015a; Regehr et al., 2015; USFWS, 2016).

Climate Change

As described in 3.1.7., climate change is expected to result in longer open water periods, decreased sea ice formation, and increased sea ice losses, which is the primary threat to polar bears. The USFWS found polar bear sea ice habitat is declining throughout the species' range, and the sea ice losses are expected to continue for the foreseeable future (Federal Register, 2008). The USFWS (Federal Register, 2008) determined the SBS and CBS polar bear stocks, as part of the "threatened" polar bear population, are not currently in danger of extinction, but they are likely to become so in the foreseeable future.

Presently, the SBS stock is currently experiencing the effects of changes in sea ice conditions (Rode et al., 2007; Regehr et al., 2007; Hunter et al., 2007; Rode et al., 2014; Bromaghin et al., 2015)). The population is vulnerable to large-scale dramatic seasonal fluctuations in ice movements, decreased abundance and access to prey, and increased energetic costs of hunting. Polar bears of the CBS stock do not seem to be responding to sea ice loss the same way as other populations are responding, such as the SBS stock, as CBS bears appear to be in good body condition and exhibit stable cub production (Rode et al., 2014).

New data continues to support that the global threat of habitat loss identified in the 2008 listing decision remains (USFWS, 2017). The USFWS (2017) reported that sea ice continues to rapidly thin and retreat throughout the Arctic and currently, there is no regulatory mechanism in place on the national or international level to address this threat. Wiig et al. (2015) reported that Arctic sea ice loss has progressed faster than most climate models have predicted (Stroeve et al., 2007). For example, NCEI (2015) reported that the year 2015 was the warmest year since records have been kept (1880 to 2015). The USFWS (2017) concluded that climate change effects on sea ice and polar bears and their prey would very likely continue for several decades or longer unless greenhouse gases in the atmosphere can be held at suitable levels, primarily by reducing greenhouse gas emissions. The USFWS continues to support the status of “threatened” under the ESA as bears continue to rely heavily on sea ice for essential life functions and Arctic warming is contributing to the continued loss of sea ice (USFWS, 2017).

3.2.5. Terrestrial Mammals

While several species of rodents and other small mammals, particularly furbearers, occur along Alaska’s North Slope, none of them have been identified as species of particular social or economic concern. For this reason they shall not be discussed further in in this document.

3.2.5.1. Caribou

Population and status

Caribou herds on the North Slope and in the area of effect of the Proposed Action include the Western Arctic Caribou Herd (WAH), the Central Arctic Caribou Herd (CAH), the Porcupine Caribou Herd (PCH), and the more sedentary Teshekpuk Lake Caribou Herd (TCH) (Figure 3.2.5-1). The WAH has declined by 4-6% annually between 2003 and 2013. An area-wide survey of caribou herds conducted by the Alaska Department of Fish and Game (ADF&G) in 2013 counted 235,000 caribou in the WAH (Dau, 2015), a decline of around 27% since the time of the last estimate (325,000) conducted in 2011 (ADF&G, 2014b; Parrett, Dau, and Nedwick, 2014; Dau, 2011). Likewise, the TCH and CAH populations changed from 2011 estimates of 55,000 and 67,000, respectively (Parrett, 2011; Parrett 2015; Lenart, 2013a), to 32,000 (42% decline) and 22,630 (66% decrease) (ADF&G 2017; Parrett, Dau, and Nedwick, 2014).

Caribou occur in the Canadian Arctic with two herds, the Cape Bathurst and Tuktoyaktuk Caribou and reindeer herds occupying habitat that could be affected by the Proposed Action but only in the event of a very large spill. Of the two Canadian herds the Cape Bathurst Caribou Herd (CBH) is larger, numbering between 16,000-22,000 individuals (Davison et al., 2014; Northwest Territories 2015a). Caribou and reindeer have formed a small herd on the Tuktoyaktuk Peninsula (TPH) numbering 1,700 - 2,556 animals (Davison et al., 2014; Northwest Territories 2015b).

Distribution

Calving Areas:

Spring migration of female caribou who are about to give birth from the overwintering areas to the calving grounds begins in late March and is correlated with the disappearance of snow cover (Hemming 1971; Bergerud, 1974). Often the most direct routes are used; however, certain drainages

and routes probably are used during calving migrations, because they tend to be corridors free of snow or with shallow snow (Lent, 1980). Severe weather and deep snow can delay spring migration, with some calving occurring en route (Bergerud, 1974; Carroll et al., 2005). Cows calving en route usually proceed to their traditional calving grounds (Hemming, 1971).

The evolutionary significance of the establishment of the calving grounds may relate directly to the avoidance of predation on the caribou calves, particularly predation by wolves (Bergerud, 1974, 1987). Caribou calves are very vulnerable to wolf predation, as indicated by the documented account of surplus predation by wolves on newborn calves (Miller, Gunn, and Broughton, 1985). By migrating north of the tree line, caribou leave the territories of most wolf packs, which mostly overlap with caribou winter ranges or in the mountain foothills or along the tree line during the wolf-pupping season (Heard and Williams, 1991; Bergerud, 1987). By calving on the open tundra, the female caribou also avoid ambush by other predators such as bears and wolverines. Furthermore the selection of snow-free patches of tundra on calving grounds helps to camouflage newborn caribou calves from other predators that hunt by sight, such as golden eagles (Bergerud, 1974, 1987).

The sequence of the spring migration, first by parturient females, then by males, non-parturient females, and yearlings is believed to be a strategy for optimizing the quality of forage as it becomes available with snowmelt on the Arctic tundra, and possibly to alleviate competition between parturient females and other caribou for forage resources during the calving season (Whitten and Cameron, 1980; Griffith et al., 2002). Within days of calving, female caribou collect their offspring and form into herds to shift to summer ranges for grazing (Bergerud, 1974).

Summer Range. Non-parturient caribou migrate to or near calving areas in spring, and remain on the move throughout the summer months, seeking nutritious forage so that they can fatten-up in preparation for the next winter. Shortly after calving females with calves form up herds with each other and with other individuals, and begin moving across the landscape, most likely as a defense against predation and insect harassment (Bergerud, 1974; Helle and Aspi, 1983), and possibly to reduce levels of parasitic infestations (Folstad et al., 1991).

Insect Relief Areas. During the post-calving period in July through August, caribou generally attain their highest degree of aggregation into large herds of animals, sometimes in excess of tens of thousands (Lawhead, 1997). During the summer months, caribou use various upland, windy, and coastal habitats, sandbars, spits, river deltas, and some barrier islands, for relief from insect pests, which reduce foraging efficiency and increase physiological stress (Reimers, 1980). Helle and Aspi (1983) postulated herd formation by caribou is used as a defense against insect harassment by reducing the seriousness of the effects on individual animals, in spite of the obvious increase in intraspecific competition for forage among the caribou.

Winter Range. Bergerud (1974) noted the role of photoperiod (period of time each day during which an organism receives illumination) on hormone production in caribou which in turn make individual animals restless with a tendency towards larger aggregations. Heavy snowfall is the final stimulus needed to encourage caribou herds to migrate to wintering areas (Bergerud, 1974). The movement and distribution of caribou over the winter ranges reflect their need to avoid predators and their response to weather conditions (snow depth and density), which greatly influence the availability of winter forage (Roby, 1980; Ferguson and Messier, 2000; Henshaw, 1968; Bergerud, 1974; Bergerud and Elliot, 1986). Consequently the numbers of caribou using a particular portion of the winter range are highly variable from year to year (Davis, Valkenburg, and Boertje, 1982; Fancy et al., 1990, as cited in Whitten, 1990).

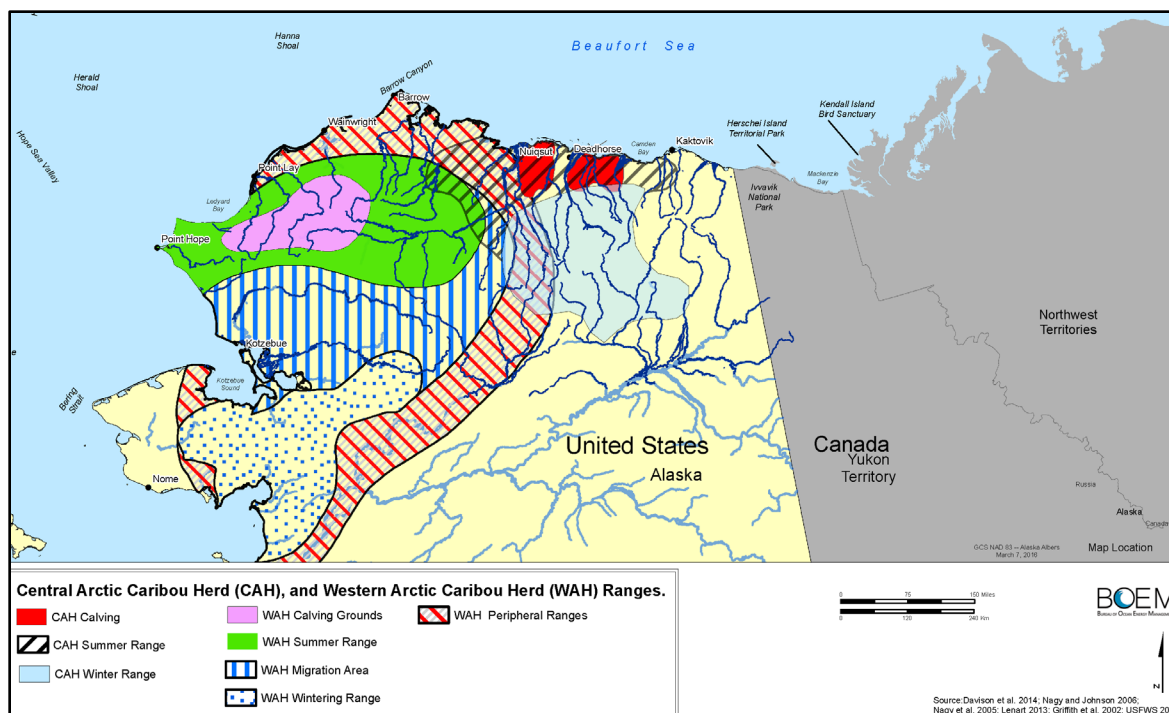

Figure 3.2.5-1. Western Arctic and Central Arctic Caribou Herd Habitats.

Western Arctic Caribou Herd (WAH)

The Western Arctic caribou herd (WAH) ranges over approximately 157,000 mi² (363,000 km²) of northwestern Alaska (Dau, 2013). During spring, most parturient cows travel north toward the calving grounds in the Utukok Hills, while bulls and nonmaternal move to the Wulik Peaks and Lisburne Hills (Figure 3.2.5-1). During the post-calving period, maternal cows and calves travel southwest toward the Lisburne Hills where they mingle with bulls and nonmaternal cows. During summer WAH caribou move east through the Brooks Range. In late summer, most bulls become relatively sedentary in the upper Noatak–Nigu river area while most cows disperse back onto the coastal plain. Most caribou from this herd are more dispersed during fall than at any other time of year as they migrate to winter ranges lying on the Seward Peninsula and the Kobuk and Koyukuk River drainages. In some years, a relatively small proportion of this herd also winters near Point Lay.

Central Arctic Caribou Herd (CAH)

The CAH migrates between summering and calving areas on the Arctic coastal plain and wintering areas south of, and in, the Brooks Range. Figure 3.2.5-1 shows the two calving areas for this herd mostly occur between the Colville and Kuparuk Rivers, and between the Sagavanirktok and Canning Rivers. The actual areas used would vary between years due to access to forage, weather, etc.

Caribou from the CAH live in an area that generally lacks topographical features providing any significant insect relief. Instead these caribou move to coastal areas that are cooler and windier to escape the biting insects. On many occasions these caribou wade and sometimes swim out into coastal lagoons to escape the insect pests, and small groups of caribou are sometimes encountered on barrier islands in the Beaufort Sea. The CAH caribou use areas nearest the Proposed Action, including their eastern calving area that lies adjacent to, and south of Stefansson Sound, Alaska. Consequently caribou from the CAH are much more likely to be encountered or disturbed by the Proposed Action than caribou from any other caribou herd in Alaska or western Canada.

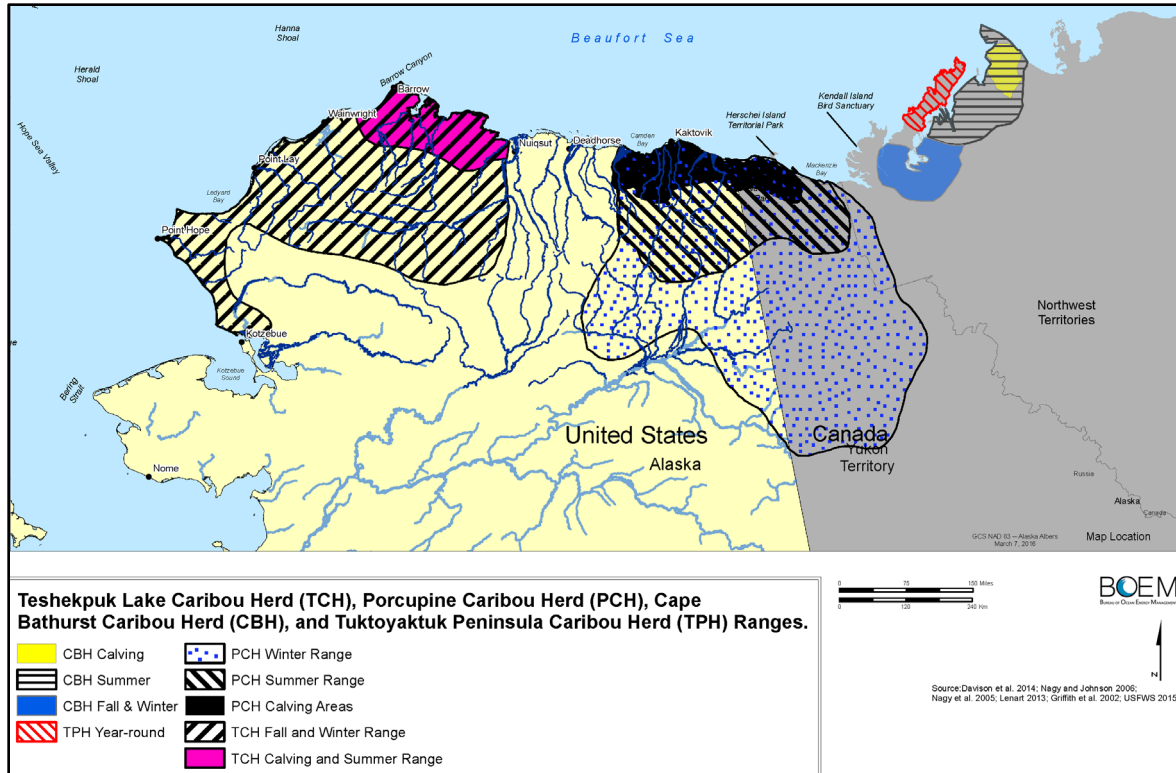

Figure 3.2.5-2. Teshekpuk, Porcupine, Tuktoyaktuk, and Cape Bathurst Caribou Herd Ranges.
Teshekpuk Lake (TCH), Porcupine (PCH), Cape Bathurst (CBH), and Tuktoyaktuk Peninsula (TPH)

Teshekpuk Lake Caribou Herd (TCH)

Archeological and traditional knowledge suggest that caribou have been abundant near Teshekpuk Lake for at least the last 400 years (Silva et al., 1985). Based on a calving distribution that was geographically distinct from the adjacent WAH and CAH, the TCH was first identified as a distinct herd in 1978 (Davis and Valkenburg, 1978). The TCH primarily inhabits the central coastal plain north of the Brooks Range during spring and summer, but has a large historical range, encompassing wintering areas across northwestern Alaska (Figure 3.2.5 2).

Members of the TCH generally aggregate close to the coast for insect relief. Some small groups, however, gather in other cool, windy areas such as the Pik Dunes located about 30 kilometers (19 mi) south of Teshekpuk Lake (Hemming, 1971; Philo, Carroll, and Yokel, 1993).

Porcupine Caribou Herd (PCH)

In spring the PCH migrates from winter ranges to the northern slope of the Brooks Range to calve in an area that extends from the foothills to the coastline, and from around the Canning River in Alaska into the Yukon Territory (Figure 3.2.5-2). After calving the PCH rapidly assembles into herds sometimes numbering into the thousands, to wander across their summer range, feeding, and rearing their calves.

Caribou from the PCH are subject to mosquito harassment from mid- June into August, and oestrid fly harassment from mid-July to late-August. To escape biting insects, caribou usually move from inland feeding areas to windswept, vegetation-free upland and coastal areas, such as sandbars, spits, river deltas, and barrier islands for relief from insect pests (USDOI, MMS, 1987). Caribou encountered on barrier islands occur in small groups numbering 20 animals or less. The primary coastal insect relief areas for WAH caribou occur between Kivalina Lagoon and Point Lay, while the TCH uses coastal insect relief areas between Point Barrow and the Colville River, and the CAH

periodically uses coastal insect relief areas between the Colville River and western Camden Bay (NOAA, 2003, 2005).

Tuktoyaktuk Peninsula Caribou Herd (TPH)

The TPH is found on the northern half of the Tuktoyaktuk Peninsula in Canada's Northwest Territories. It has been suggested this herd reoccupied the range after domestic reindeer was removed from the peninsula, and crossbreeding between these caribou and reindeer may have occurred (Northwest Territories, 2015b) as has occurred elsewhere. The TPH lives an existence that is mostly sedentary when compared to the PCH or WAH, mostly remaining on the Tuktoyaktuk Peninsula year-round (Figure 3.2.5-2).

Cape Bathurst Caribou Herd (CBH)

The CBH migrates from their wintering grounds to their calving areas in the northern areas of Cape Bathurst. After calving, they generally move to the tip of Cape Bathurst, before shifting to summering ranges directly to the south. Eventually as fall and winter approach, these caribou move to their winter ranges in the lower Tuktoyaktuk Peninsula and the areas east and south of the southern Tuktoyaktuk Peninsula (Figure 3.2.5-2)

Life History

Caribou begin breeding at about 28 month of age, though females in very good physical condition have been known to breed as early as 16 months (ADF&G, 2015). Calving takes place in the spring, generally from late May to late June enroute to or at the calving grounds (Bergerud, 1974; Hemming, 1971). Typically, most pregnant cows reach the calving grounds by late May, where they give birth from the time of arrival into early June. Calving is synchronized with the timing of plant growth such that parturient females have access to fresh, nutritious vegetation when it is most needed (Post et al., 2003); however, an added advantage to synchronized calving is that predators hunting caribou calves are inundated or "swamped" by the sheer number of calves, limiting the window of opportunity for predators to kill and consume newborn caribou calves (ADF&G, 2015).

Within days of birth caribou cows with their calves form into herds and by mid-June commence wandering across the Brooks Range foothills and the ACP. These, sometimes large, aggregations aid in escaping predators and insects (Bergerud, 1974; Dau, 2005; ADF&G, 2015) and possibly reduce the risk of parasitic infestations (Folstad et al., 1991). During summer caribou continue moving over their summer rangelands feeding to put on fat and muscle mass for winter survival, and also encourage gestation as applicable (Bergerud, 1974; Adams, 2003; Gerhart et al., 1996).

As the fall season sets in and day length decreases, the loss of daylight elicits hormonal changes in individual animals making them restless and more gregarious, and they shed the velvet from their antlers (Bergerud, 1974; ADF&G, 2015). With the first heavy snowfall, these caribou commence their fall migration from their summer ranges to winter ranges shown in Figures 3.2.5-1 and 3.2.5-2.

The rut occurs sometime in October, after the fall migrations, and caribou bulls battle for the right to breed for the next 3-4 weeks (Maier and White 1998; ADF&G, 2015). Most fights between bulls are brief, though some can become violent, and caribou bulls are often injured or killed outright (ADF&G, 2015). After the rut ends bulls shed their antlers; however females and small bulls typically retain their antlers until sometime in April, and pregnant females even into early June (ADF&G, 2015).

Diet

The caribou diet shifts from season to season and depends on the availability of forage. In summer (May-September), caribou eat the leaves of willows, sedges (grasslike plants), flowering tundra plants, and mushrooms. Caribou calves, especially, depend on cotton-grass (*Eriophorum* spp) for nutrition. Leafy shrubs (especially willows) are the predominant forage during the post-calving period

(Lent, 1966; Thompson and McCourt, 1981; Eastland, Bowyer, and Fancy, 1989). The availability of sedges during spring, which depends on temperature and snow cover, likely affects specific calving locations and calving success rates. After insect numbers drop in August, caribou disperse to feed on willows and mushrooms to regain weight.

In fall and winter most caribou herds switch to lichens (*Cladina* and *Claytonia* spp. mostly), sedges (grasslike plants), and small shrubs (Arctic willow, blueberry, etc.) (ADF&G, 2015). Less migratory herds, such as the TCH, which winters where relatively few lichens are present, may consume more sedges and vascular plants and less lichen and willow than migratory herds like the WAH or PCH. Similarly, the CBH at Cape Bathurst relies more on lichens and less on graminoids and willows (Parrett, 2007). After winter caribou shift their diet back to vascular plants such as cotton-grasses (*Eriophorum* spp.), other sedges, grasses, willows, forbs, etc. (Lent, 1966; Thompson and McCourt, 1981).

Mortality

The primary predators of caribou are wolves; grizzly bears, golden eagles, and wolverines vary in prominence as conditions dictate (Bergerud, 1983; ADF&G, 2015; Crête and Manseau, 1996; Young et al., 2002; Johnson et al., 1996). Caribou in Alaska are also affected by brucellosis (Neiland et al., 1968), and other microbial pathogens (Zarnke, 1983), as well as from parasites (Folstad et al., 1991). Approximately 15,791 caribou from the WAH (Dau, 2013), 1,850 from the PCH (Caikoski, 2013), 3,386 from the TCH (Parrett, 2013), and 1,129 from the CAH (Lenart, 2013a) were harvested for subsistence and recreational hunting in Alaska during 2011.

Climate Change

In recent years, shrubs and trees have been observed growing in places where they previously did not exist; the potential for shrub and tree encroachment into the Arctic has become a cause for concern (McNew et al., 2013). The successful development of new plant communities, and the northward advance of trees and shrubs would depend on the genetically regulated abilities of a species to adapt to new environmental conditions (Nicotra et al.; 2010; Shaw and Etterson, 2012; Franks and Hoffmann, 2012). Consequently there may be genetic limitations to how far north a plant species can grow, an environmental limitation other than temperature and precipitation; meaning trees and shrubs in northern Alaska may lack the genetic flexibility necessary to germinate and grow along the Chukchi and Beaufort Sea coastlines or on the ACP.

Kaarlejärvi (2014) determined herbivores such as reindeer (caribou), and microtines can prevent lowland forbs from invading areas of open tundra through herbivory, and that herbivores counteract the effects of climate warming by slowing or preventing the invasion of new plant species into tundra systems. Cahoon et al. (2012) determined large herbivores can mediate the responses of Arctic ecosystems to climate change through herbivory. Thus, maintaining healthy populations of caribou and other large herbivores in the Arctic may offset many of the ecological effects of climate change such as shifts in diversity, invasion by novel new species, and transitions to novel new ecological communities.

Beest et al. (2016) found when reindeer reduces shrub height and abundance, summer albedo increases in shrub-dominated vegetation and willow-dominated depressions. Results revealed lower net radiation, and latent and sensible heat fluxes in heavily-grazed sites in all shrub-dominated vegetation types, suggesting a structural shift from graminoid to shrub tundra drives the difference in summer albedo, rather than shifts from dwarf-shrub to tall-shrub tundra. Consequently caribou/reindeer had a potential cooling effect on climate by increasing summer albedo and decreasing net radiation.

An effect of longer, warmer growing seasons with a deeper layer of thawed permafrost is increased root production by vascular plants. A shift to earlier emergence of plants could potentially lead to a

trophic-mismatch between plant development, nutritional quality of plants, and caribou calving and grazing (Kerby and Post, 2013). Increases in growing season length, temperatures, permafrost thawing, and increased precipitation could be advantageous to the production of vascular forage plants on summer ranges. The increase in vascular range plants would result in a corresponding loss to non-vascular winter range plants such as lichens, however, which could be detrimental to caribou. Caribou can be affected by the loss of sea ice in the Arctic. Without ice to moderate the effects of wind on the ocean's surface, larger storm events which could destroy extensive areas of coastal habitat over time could occur throughout the Beaufort Sea.

Increasing fire frequency is another characteristic of climate change in the Arctic and could lead to the long-term destruction of caribou winter ranges; some area may take 50 years or more to recover from fires (Joly, Duffy, and Rupp, 2012; Gustine et al., 2014).

Recently, the topic of winter rain-on-snow event degradation of caribou winter ranges has been discussed. Tyler (2010) found little empirical evidence supporting such a view exits, and concluded the effects of climate variability on caribou are “dwarfed” by the effects of density-independent factors of politics, social issues, and economics. Since 2010 other studies have been conducted which support the assumption of adverse effects from rain-on-snow events (Descamps et al., 2017; Langolis et al 2017; Hansen et al., 2011; Hansen et al., 2014).

For these reasons climate change across the North Slope would have mixed effects on caribou along the North Slope and those near the Beaufort Sea.

3.2.5.2. Muskox

Population and status

Indigenous populations of muskoxen were extirpated in the 1800's in northern Alaska (Smith, 1989). Muskoxen were reintroduced on the Arctic National Wildlife Range (which became the Arctic National Wildlife Refuge (ANWR), now referred to as the Arctic Refuge, in 1980) in 1969 and in the Kavik River area (between Prudhoe Bay and the ANWR) in 1970; they were reintroduced west of the NPR A near Cape Thompson in 1970 and 1977 (Smith, 1989).

There are approximately 4,200 (Gunn et al., 2013) muskoxen in Alaska, occurring in northcentral, northeastern, and northwestern Alaska, on Nunivak and Nelson Islands, the Seward Peninsula, and the Yukon-Kuskokwim Delta. In recent years, the herds in northeastern Alaska, especially those in the ANWR and adjoining areas, have declined, presumably due to grizzly bear predation (ADF&G, 2015; Reynolds, Reynolds, and Shideler, 2002).

In 1998, a total of about 800 muskoxen were observed in the 500-kilometer area between the Itkillik River west of Prudhoe Bay and the Babbage River in northwestern Canada (Reynolds, 1998). By 2013, ADF&G estimated that there were >200 muskoxen on the Central and Eastern Arctic Slope, down from 302, most likely because of grizzly bear predation (Lenart, 2013b; Arthur and Del Vecchio, 2013).

Distribution

Muskox herd sizes are often small, consisting of a few calves mixed in among adults and yearlings. As a rule they are sedentary, usually remaining within a limited geographical area, though young males and sometimes females wander great distances. Recent radio-tracking of 121 adult female muskoxen in northwestern Alaska showed females moving across large geographic areas, contrary to prior assumptions regarding muskox site fidelity (Adams, 2013).

The most important habitats for muskoxen appear to be riparian, upland shrub and moist sedge-shrub meadows (Johnson et al., 1996). Muskoxen generally do not migrate but will move in response to

seasonal changes in snow cover and vegetation. They use riparian habitats along the major river drainages on the Arctic

The reintroductions to the east established the ANWR population, which grew rapidly and expanded both east and west of the Refuge (Garner and Reynolds, 1986). North slope muskoxen are found as far east as the Babbage River in northwestern Canada and as far west as the Kogru River. Common drainages where muskoxen have been observed include the Colville, Itkillik, Kuparuk, Sagavanirktok, Canning, Sadlerochit, Hulahula, Okpilik, Jago, and Aichilik rivers (Lenart, 2013b). Muskoxen occur from Cape Lisburne to Canada and from the Brooks Range to the Arctic coast, with fewer found in ANWR and more towards the western Brooks Range (Lenart 2013b; Westing 2013). A release of muskoxen at Cape Thompson on the Chukchi coastline and on the Seward Peninsula that resulted in range expansion northward into the western Brooks Range, west to Cape Lisburne (Westing 2013), and they have been spreading into the Gates of the Arctic National Park and Preserve since at least 1989 (Lawler 2003). Generally sedentary, muskoxen occasionally make impressive journeys. One tagged muskox cow traveled from the Igichuk Hills to Corwin Bluff in 2009-2010 (Westing, 2013).

Life History

Calving takes place from about April to early June (Garner and Reynolds, 1987). Distribution of muskoxen during the calving season, summer, and winter are similar, with little movement during winter (Reynolds, 1992). The breeding season begins during late summer, followed by mating which occurs between August and October (ADF&G, 2015). Smaller harem groups that form in the mating season may contain 5 to 15 females and sub-adults, with one dominant bull. The dominant bull muskox prevents other adult bulls from entering the group, and bulls excluded from such breeding herds wander widely in search of a harem during summer. Winter herds may include up to 75 animals, and generally, lone bull muskoxen that were excluded during the mating season will join herds during winter. During winter, muskoxen mostly stay in place and rely heavily on the energy reserves they've accumulated over the spring, summer, and fall to survive (Adamczewski, Hudson, and Gates, 1993).

Diet

Muskoxen eat a wide variety of plants, including grasses, sedges, forbs, and woody plants particularly willows. They are poorly adapted for digging through heavy snow for food, so winter habitat is generally restricted to areas with shallow snow accumulations or areas blown free of snow (ADF&G, 2015).

Mortality

Grizzly bears are the primary predators for muskoxen and have been implicated in muskox population declines in some areas of Alaska (Westing, 2013; Lenart, 2013b). To a much lesser extent muskoxen are hunted, however with declining herd numbers opportunities to hunt muskox will also decline. Since caribou in Alaska have been exposed to *Brucella*, it is likely muskoxen have been exposed too considering their shared habitat preferences; however, brucellosis has not been shown to be a causal agent in any population declines of muskoxen or directly associated with any muskoxen mortalities.

Climate Change

As sea ice losses continue to increase, larger storm events may occur throughout the Arctic Ocean, and without sea ice to moderate the effects of winds on water, large waves and swells would develop which could impact coastal habitat over time. Increases in growing season length, temperatures, permafrost thawing, and increased precipitation could be advantageous to the production of vascular forage plants on summer ranges, which would be a positive effect for muskoxen. An effect of longer, warmer growing seasons with a deeper layer of thawed permafrost is increased root production by vascular plants, and a shift to earlier emergence of plants that could lead to a trophic-mismatch

between plant development, nutritional quality of plants, and muskox calving and grazing as Kerby and Post (2013) observed for caribou. However, the non-migratory behavior of muskoxen may prevent trophic-mismatches between muskox and their forage species. Increasing fire frequency could lead to the long-term destruction of musk ox winter ranges; however, seral stages that follow Arctic wildfires would include graminoid, forb, and shrub communities that could favor muskoxen.

Changes in long term flora on the North Slope could affect Arctic herbivores. In recent years, shrubs and trees have been observed growing in places where they previously did not exist. The potential for shrub and tree encroachment into the Arctic has been a cause for concern (McNew et al., 2013); however, the development of new plant communities, and the northward advance of trees and shrubs would depend on genetically regulated abilities of each species to adapt to new environmental conditions (Nicotra et al.; 2010; Shaw and Etterson, 2012; Franks and Hoffmann, 2012).

Consequently, genetic limitations may limit how far north a plant species can grow; meaning trees and shrubs in northern Alaska may lack the genetic flexibility necessary to germinate and grow along the Chukchi and Beaufort Sea coastlines or on the ACP. With a mixture of habitat, muskoxen would ideally graze sedge meadows on the ACP in summer, and use shrublands during winter for cover and browse from time-to-time.

Beest et al. (2016) found when reindeer reduces shrub height and abundance, summer albedo increases in shrub-dominated vegetation and willow-dominated depressions. Results revealed lower net radiation, and latent and sensible heat fluxes in heavily-grazed sites in all shrub-dominated vegetation types, suggesting a structural shift from graminoid to shrub tundra drives the difference in summer albedo, rather than shifts from dwarf-shrub to tall-shrub tundra. Consequently caribou/reindeer had a potential cooling effect on climate by increasing summer albedo and decreasing net radiation. Muskox are browsers, and their affinity for browsing may act to increase the albedo which would subsequently decrease temperatures to a point, as was suggested by Beest et al. (2016) for reindeer.

Kaarlejärvi (2014) determined mammalian herbivores can prevent lowland forbs from invading areas of open tundra through herbivory, and that herbivores counteract the effects of climate warming by slowing or preventing the invasion of new plant species into tundra systems. Cahoon et al. (2012) determined large herbivores can mediate the responses of Arctic ecosystems to climate change through herbivory. Thus maintaining healthy populations of muskoxen, and other large herbivores in the Arctic may offset many of the ecological effects of climate change such as shifts in diversity, invasion by novel new species, transitions to novel new ecological communities, etc. Under the current climate change projections muskoxen numbers may actually increase along the North Slope. Recently, the topic of winter rain-on-snow event degradation of caribou winter ranges has been discussed; however, muskoxen rely on stored reserves during much of the winter and generally do not browse or graze extensively, though some foraging does occur. A 2003 rain-on-snow event on banks island is believed to have resulted in the deaths of around 20,000 muskoxen due to starvation, and muskoxen venturing onto loose sea ice searching for food (Grenfell and Putkonen, 2008; Putkonen and Roe, 2003; Rennert et al., 2009). Consequently, the effects of icing on muskox winter habitat would likely be moderate since some deaths could occur; however, the muskox preference for “shrubby” habitat that is increasing in some areas of Arctic Alaska could provide some positive effects to muskoxen through the creation of new habitat.

3.2.5.3. Grizzly Bears

Population and status

The grizzly bear population on the western North Slope was considered stable or slowly increasing in 1991. Densities were highest in the foothills of the Brooks Range and lowest on the Arctic North Slope (Carroll, 1991). Lenart (2013c) estimated a population of 656 grizzly bears in Game Units 26B

and 26C; however, the overall number of grizzlies in the U.S. Arctic is likely much higher since Carroll (2013) did not attempt population estimates for Game Management Unit 26A, while noting densities appeared to be at high levels relative to carrying capacity.

Distribution

Presently no known concentration areas on the Beaufort Sea coastline have been documented other than the area near Kaktovik where they can feed on bowhead whale carcasses in the fall (Miller, Wilder, and Wilson, 2015). Some inland waterways, such as the Colville and Sagavanirktok Rivers, support modest spawning runs of anadromous fish, and bears are assumed to exploit such resources. Consequently, streams supporting anadromous fish may become temporary concentration areas for grizzly bears.

An estimated 60-70 bears or approximately 4 per 1,000 km² currently inhabit the central North Slope Coastal Plain (Shideler and Hechtel, 2000). Since 1990, the ADF&G has captured and marked 121 bears between Teshekpuk Lake and the Canning River while studying the bears' use of the oil fields (Shideler, 2006b, pers. comm.). These bears have very large home ranges (201-13,880 km² (Shideler, 2006b, pers. comm.) and travel up to 50 kilometers a day (Shideler and Hechtel, 2000). In 1992, the estimated population for Game Management Unit 26A, the area west of the Ikillik River and which includes all of NPR-A, was 900-1,120 bears (Carroll, 2005).

On the North Slope, grizzly bear densities vary from about 0.3-5.9 bears per 100 mi², with a mean density of 1 bear per 100 mi².

During winter grizzlies den in pingos, banks of rivers and lakes, sand dunes, and steep gullies in uplands (Harding, 1976; Shideler and Hechtel 2000), primarily in the last 2 weeks of September through early November. In mid-April to early June they begin to emerge from their dens before most caribou begin calving, with adult males entering dens the latest and emerging the earliest (McLoughlin, Cluff, and Messier, 2002; Shideler and Hechtel, 2000).

Life History

Diet

Grizzly bears forage in riparian areas, river deltas, coasts, and uplands in response to food availability or other habitat needs. In the western Brooks Range they use a variety of food sources including caribou, beach-cast marine mammal carcasses and, to some degree, seasonal salmon and Dolly Varden runs that occur in larger streams. Grizzlies also enjoy excavating Arctic ground squirrel burrows to capture and consume Arctic ground squirrels, and often go out of their way to engage in such behavior (Mueller, 1995).

Grizzlies in the Arctic require very large home ranges compared to bears farther south due to the brief growing season and low productivity in the Arctic. Mowat and Heard (2006) noted grizzly bear diets eastward of Harrison Bay on the ACP show a larger fraction of meat from terrestrial sources ($\geq 45\%$ of diet), suggesting a greater nutritional dependence on animal matter vs. plant matter among Arctic grizzlies than is observed elsewhere. Grizzly diets in more productive areas contain around 80-90% plant matter and 10-20% animal matter.

Mortality

The only naturally occurring predators for grizzly bears in the U.S. Arctic are other grizzly bears, and the rare occasion when a wolf pack discovers a hibernating bear, or the rare instance when a polar bear finds and kills a grizzly cub. Sport hunting and subsistence hunting are the two primary sources of mortality among grizzly bears on the North Slope and those numbers are low. Lenart (2013c) counted 22 bears harvested in Game Management Unit 26B and 15 in Game Management Unit 26C in 2011, while Carroll (2013) concurrently observed a harvest of 22 bears in Game Management Unit

26A. Both authors acknowledged the likelihood that some harvested by local residents might to unreported.

Climate Change

As sea ice losses continue to increase larger storm events may occur throughout the Arctic Ocean, and without sea ice to moderate the effects of winds on water, large waves and swells would develop which could impact coastal habitat over time. Such storms are more likely to deposit marine mammal carcasses and other food resources onshore that would have a positive effect on grizzlies engaged in scavenging for food.

Increases in growing season length, temperatures, permafrost thawing, and increased precipitation could be advantageous to the production of vascular forage plants on summer ranges, which would be a positive effect for grizzlies. One effect of longer, warmer growing seasons with a deeper layer of thawed permafrost is increased root production which leads to shifts from non-vascular plants to vascular plants, and a shift to earlier plant emergence that could become an important source for grizzly bears emerging from hibernation. Increasing fire frequency could lead to the conversion of moss and lichen-dominated ecological communities, to graminoid and forb-dominated ecological communities that may be better habitat for Arctic ground squirrels and other species grizzlies prey on that also include muskox, moose, and caribou. Grizzlies respond to fluctuations in prey species numbers by switching to other food sources such as salmon, and this behavior would likely continue into the future. For this reason they should be more resilient to the effects of climate change than species' that have a more specialized diet. They may also shorten their denning period in response to climate change effects to the duration and severity of winter, and a deeper permafrost melt might increase the amount and quality of denning sites. Under the current climate change projections, grizzly numbers could increase throughout the North Slope, providing they have access to sufficient numbers of prey animals and forage plants.

3.2.5.4. Arctic Fox

Population and status

The Arctic fox population on the North Slope has increased since 1929, as the values and harvest rates of white fox pelts declined (Chesemore, 1967). Alaska Department of Fish and Game (Caikoski, 2010; Carroll, 2010) reported healthy numbers of Arctic foxes in the U.S. Arctic, meaning Arctic fox populations in the U.S. Arctic remain self-sustaining.

Distribution

Arctic foxes (*Vulpes lagopus*) are ubiquitous and numerous throughout U.S. Arctic, and sometimes “island-hop” through the barrier islands of the Beaufort Sea, scavenging, raiding bird nests, and caching food for later use. Arctic foxes on the Prudhoe Bay oil field readily use development sites for feeding, resting, and denning; their densities are greater in the oil fields than in surrounding undeveloped areas (Eberhardt et al., 1982; Burgess et al., 1993). Development on the Prudhoe Bay oil fields probably has led to increases in fox abundance and productivity (Burgess, 2000).

Life History

Mating occurs in early March and early April, followed by a 52 gestation period (ADF&G, 2015). They mostly breed on the coastal plain in coastal regions and most dens have southerly exposure, and extend six to 12 feet underground. Enlarged ground squirrel burrows with several entrances are often used as dens.

Pups are born in litters of up to 15 in dens excavated in sandy, well-drained soils on low mounds, hillocks, and river banks. Adults are monogamous in the wild, and split the duties of bringing food to

the den and rearing the pups. Pups begin eating meat at about one of age and wean at around six weeks (ADF&G, 2015).

Starting at an age of about three weeks they begin to hunt, and begin cutting their association with the den around three months. In September and October the family units begin to disintegrate and by mid-winter Arctic foxes are mainly leading a solitary existence, reaching sexual maturity at nine to 10 months (ADF&G, 2015).

Diet

Fox populations peak whenever lemmings (their main prey) are abundant. Other food sources include ringed seal pups and the carcasses of other marine mammals and caribou, which are important throughout the year (Chesemore, 1967; Hammill and Smith, 1991). Tundra nesting birds also are a large part of their diet during the summer (Chesemore, 1967; Fay and Follmann, 1982; Quinlan and Lehnhausen, 1982; Raveling, 1989). The availability of winter food sources directly affects the foxes' abundance and productivity (Angerbjorn et al., 1991).

Marine mammals, including carrion, and ringed seal pups are an important diet item for Arctic foxes occurring along the coasts (Anthony, Barten, and Seiser, 2011).

Mortality

Arctic foxes are particularly subject to outbreaks of rabies, and their populations tend to fluctuate with the occurrence of the disease and with changes in the availability of food. In recent years red foxes have been expanding their species range into the Arctic such that they may be found anywhere on the ACP or in the Brooks Range foothills. Red foxes habitually attack, dominate, and kill Arctic foxes when they encounter one another and this behavior was documented by Pamperin, Follman, and Peterson (2006). Other than predation from large raptors, red foxes, wolves and terminal mishaps, trapping is the largest source of anthropogenic mortality amongst Arctic foxes with at least 109 harvested in Game management Unit 26B as reported by ADF&G (2013).

Climate Change

Furbearing mammals, such as Arctic foxes, can be affected by climate change in the Arctic. Larger storms coming off the ocean are more likely to deposit marine mammal carcasses and other food resources onshore, which would be a positive effect for foxes scavenging on carrion. Another positive benefit of climate change could be the increased biological productivity that a warming climate would have throughout the terrestrial plant communities. Such productivity would initially include increased plant vegetative production, which would provide increased forage for herbivores over a longer growing season. Healthier and more abundant prey species, or new prey species, would have beneficial effect on Arctic foxes through a more diverse diet with increased caloric value. For example, a decrease in caribou numbers might be compensated for by increases in rodent, muskox, moose, or sheep numbers due to better range conditions and milder temperatures. For Arctic foxes having a resident population of prey species to rely upon rather than migratory caribou, could mean consistent, high quality nutrition throughout the year, rather than hunger interspersed with periodic episodes of feasting when caribou calve or migrate through an area, or as carrion becomes available.

An adverse effect of climate change on Arctic foxes could occur by concurrent increases in red foxes along the North Slope. Red foxes prey on, and displace Arctic foxes (Frafjord, Becker, and Angerbjörn, 1989; Pamperin, Follmann, and Petersen, 2006; Tannerfeldt, Elmhagen, and Angerbjörn, 2002), and increasing numbers of red foxes in the future could potentially displace or eliminate Arctic foxes from habitats important to their continued presence on the ACP.

3.2.6. Vegetation, Wetlands and Substrate

This section describes the nearshore and onshore/inland vegetative communities that could potentially be affected by the Proposed Action’s onshore or offshore activities. Figure 3.2.6-1 presents a vegetation and wetland delineation map of the Proposed Action Area and a summary of the distribution of wetland types is found at Table 3.2.6-1.

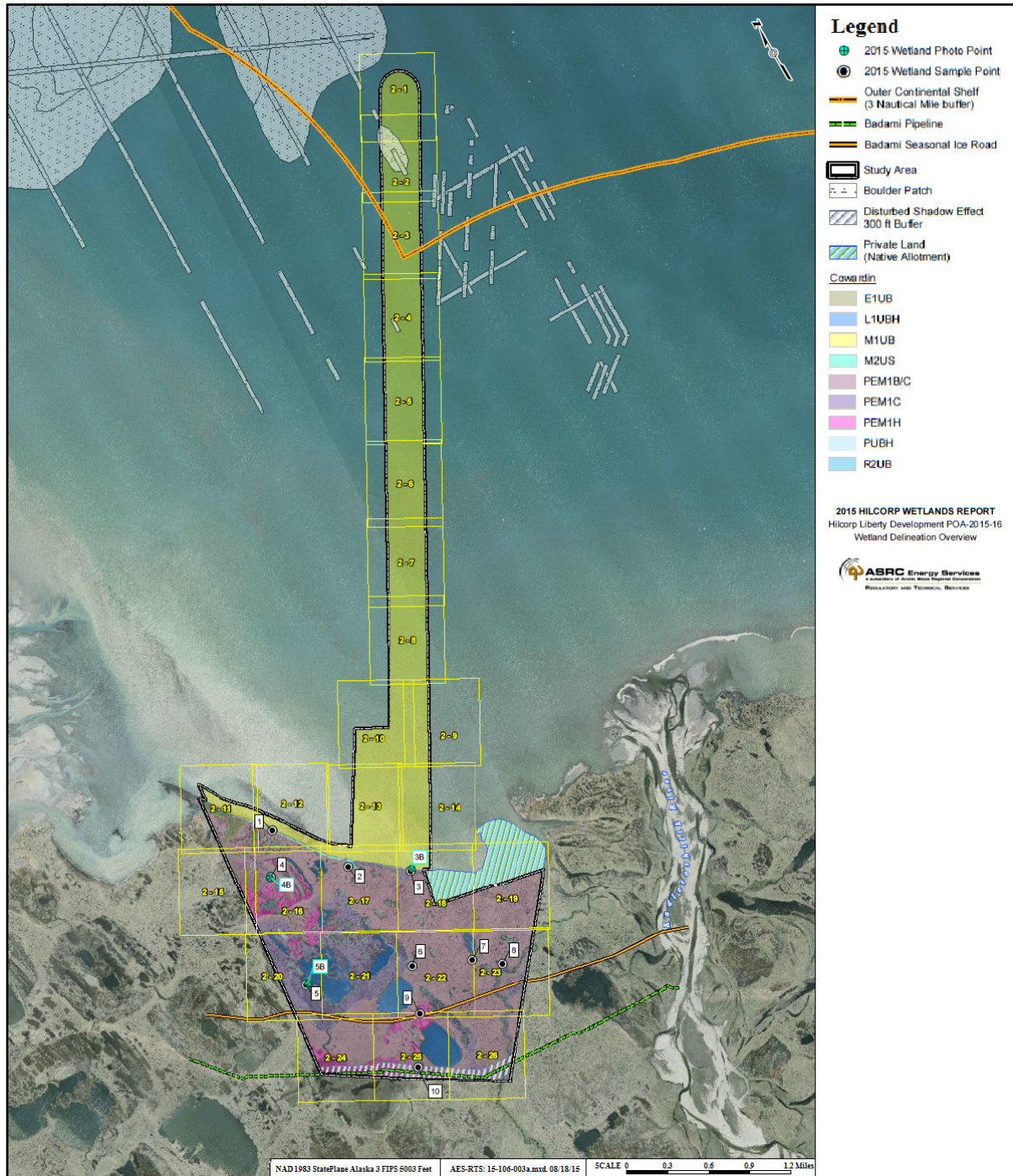

Figure 3.2.6-1. Vegetation and Wetlands Delineation of the Proposed Action Area (AES, 2015, Figure 1).

AES prepared an aquatic site assessment (ASA) for the Proposed Action Area wetlands (see Appendix E, Liberty Development Wetland Delineation Report, Foggy Island Bay, Alaska, August 2015). The ASA (Table 4.3-1, Appendix C in Appendix E) found that most of the wetlands were pristine and high functioning; but not: rare, unique, being used for science, or under threat from upstream sediments or toxins. All other WOUS (marine, estuaries, lakes, and rivers) in Alaska are automatically rated as Category I. Wetlands in the project area are evaluated as Category I or II (Table 4.3-1 and Table 4.3-2). Areas of Marine Boulder Patches and *Arctophila fulva* rated as Category I+, were also mapped to illustrate their location (Appendix E).

Soils in the study area consist of thick organic layer overlying permafrost (histosols and histic epipedons). Thick sand and gravel deposits are layered with varying amounts of fines and silt/clay interbeds. Permafrost is found at a depth between 9 and 15 inches, and can range from 650 to 2100 feet thick. Patterned ground with small rises and depressions is common throughout the area. Active layer depths can range from approximately 1 to 4 feet, with an average of about 1.5 feet.

The Arctic Coastal Plain (ACP) is a physiographic province dominated by periglacial features (thaw lakes, marshes, and polygonal patterned ground) that provide little topographic relief. The area is characterized by poorly drained soils, lakes, and irregular coastline containing many small bays, lagoons, spits, beaches, and barrier islands. With the exception of thaw bulbs under larger lakes and streams, permafrost is continuous across the ACP (Jorgenson and Shur, 2007).

All of the nearshore and onshore areas that would be impacted by the Proposed Action's construction are classified by the U.S. Fish and Wildlife Service (USFWS) as wetlands. Construction associated with the Proposed Action would impact wetlands and deeper water habitat. A permit from the U.S. Army Corps of Engineers (USACE), under Section 404 of the Clean Water Act would be required for the discharge of fill in wetlands, or the discharge of fill into territorial seas below the mean high tide line. This section discusses vegetation, wetlands and soils within the Proposed Action Area (see Figure 3.2.6-1), and the substrate in the Beaufort Sea that could be impacted by the construction of the buried pipeline.

BOEM has adopted by reference (in Appendix E), the Liberty Development Wetland Delineation Report, Foggy Island Bay, Alaska, performed by ASRC Energy Services (AES) (2015). This wetland and WOUS delineation study was performed in accordance with the USACE Wetlands Delineation Manual (Environmental Laboratory, 1987) and the Regional Supplement to the USACE Wetland Delineation Manual: Alaska Region (Version 2.0) (USACE, 2007). Additionally, AES (2015) performed an Aquatic Site Assessment based on the wetlands functions and values as described by the Arctic Slope Regional Corporation's Wetland Mitigation Bank's "Arctic North Slope Rapid Assessment method" (ANSRAM). The summary of this analysis can be found in Appendix E.

3.2.6.1. Arctic Vegetation Types Potentially Affected.

Table 3.2.6-1. Summary of Wetlands Distribution in the Proposed Action Area.

Cowardin Code	Description	Acres 10/404	Acres OCS
PEM1B/C	Palustrine Emergent Persistent Saturated/Seasonally Flooded	1044	
PEM1C	Palustrine Emergent Persistent Seasonally Flooded	357	
PEM1H	Palustrine Emergent Persistent Permanently Flooded	172	
PUBH	Palustrine Unconsolidated Bottom Permanently Flooded	82	
R2UB	Riverine Lower Perennial Unconsolidated Bottom	8	
L1UBH	Lacustrine Limnetic Unconsolidated Bottom Permanently Flooded	180	
M1UB,M2US	Marine Subtidal Unconsolidated Bottom/Marine Intertidal Unconsolidated Shore	1081	225
E1UB	Estuarine Subtidal Unconsolidated Bottom	24	

Source: AES, 2015, Appendix E.

Wetlands

Emergent wetlands are dominated by herbaceous angiosperms, and are the primary vegetated ecosystem in the project area. Emergent wetlands types differ with variances in hydrologic regime on the landscape and due to interaction with permafrost.

Wetlands with saturated hydrological regimes (PEM1B/C) are characterized by having soils periodically saturated with water during the growing season. These had the greatest variety in characteristics over the study area. Almost all of these had patterned ground formed from ice wedges being thrust to the surface, creating small rises and depressions throughout the area. These rises and depressions were examined for the possibility of wetland/upland mosaics, but found that the highest, driest rises still had wetland vegetation and soil characteristics. Saturation and/or high water tables were found in the depressions of the patterned ground. These PEM1B/C areas had a variety of vegetation, including very low shrubs such as *Salix* and *Arctous*, and herbs like *Eriophorum* and *Carex*. Soil profiles tended to have shallow permafrost, with organics observed. Hydrology is expected to perch on top of the shallow permafrost during spring snowmelt, flooding, and/or precipitation events to create anoxic conditions during the growing season.

Wetlands with seasonally flooded hydrological regimes (PEM1C) are characterized by having soils seasonally inundated with water during the growing season. These areas had greater high centered polygon topographic relief. These polygons were examined for the possibility of upland/wetland mosaics; but no evidence was found to support that type of problematic wetland. The depressions indicated evidence of seasonal flooding. PEM1C wetlands had a large number of very small shrubs present including small *Salix* and *Dryas*, along with large amounts of *Carex*. Soil profiles consisted of histic epipedons, with approximately 8 inches of saturated fibric organic and deeper layers of darker mineral soils. These are due to the colder Arctic temperatures and the anaerobic conditions due to the seasonal flooding.

Wetlands with permanently flooded hydrological regimes (PEM1H) are characterized by having soils frequently inundated with water during the growing season. These were low centered polygonal tundra, with large polygons and shallow water tables. These areas have relatively deep permafrost (15 inches) and thick layers of fibric organic material developed from the longer anaerobic conditions caused by permanent flooding. Few shrubs were present and vegetation consisted of *Carex* and *Eriophorum*.

Ponds (PUBH)

There are a great number of ponds in the project area. On the North Slope, ponds are often less than 20 acres large. They have a variety of wetland dependent plants supporting waterfowl and other types of wildlife.

Rivers (R2UB)

Riverine systems are present in the study area, with bed and bank features and ordinary high water lines. These river systems convey waters through the flat topography to the Beaufort Sea. These are low gradient systems, and water velocity is slow. Water may flow throughout the year; but given the harsh conditions of the Arctic, some flow may be seasonal. The substrate was observed to be sand and mud. No signs of fish were observed, and the Alaska Department of Fish and Game does not list Anadromous Fish Streams in the study area.

Lakes (L1UBH)

Lakes have complicated characteristics on the North Slope, often with very shallow banks, large littoral zones, and polygonal bathymetry due to the underlying permafrost. Some lakes freeze solid during the winter, while others are deep enough to have free water at depths greater than 5 feet. On

the North Slope, lakes are often greater than 20 acres. The large littoral zones of lakes were found to often support dense habitats of aquatic vegetation.

Marine (M1UB, M2US)

The northern area of the project is the Beaufort Sea. The Beaufort Sea (a Traditional Navigable Water (TNW)) is the dominate habitat for the project. The shoreline in the project area consists of small (3-5 foot) bluffs where permafrost is eroding into the ocean. Cold Arctic winds circulate, keeping vegetation small and stunted, and the majority of the year the ocean is covered in sea ice.

Estuary (E1UB)

On the far western edge of the project area is a small estuary system which appears to hold brackish water, and be the floodplain for some riverine systems. These areas are important transition zones between salt and freshwater environments, and provide a location for turbidity to fall out prior to entering the ocean. These locations can also provide some fish species overwintering habitat. As freshwater areas freeze shut, estuaries can be refuges for typically salt water species.

Arctophila fulva

Arctophila fulva is an herbaceous plant which is of particular interest to conservation agencies due to its importance to waterfowl habitat. This plant has been identified to be important for many species including Endangered Species Act Steller's eiders; which seasonally inhabit the North Slope. Studies near Utqiaqvik have found that most (80 percent) Steller's eider broods are in *Arctophila fulva* habitat (Quakenbush et al., 2004).

In the study area *Arctophila fulva* is found at the edges between lacustrine, riverine or marine systems adjacent to wetland areas. These are where wetlands border bodies of water that have seasonal periods of surface water. In these locations, *Arctophila fulva* is dense and ubiquitous where it has not been heavily grazed. Many flocks of waterfowl and geese were observed in the *Arctophila fulva* areas.

Arctophila fulva was not found in the central region of the study area, where the Proposed Action is planned. These non-fulva areas are along the lacustrine/emergent wetland border areas (L1UBH-PEM1B/C or L1UBH-PEM1H). These habitats have better banks; without the gently increasing gradient in water depth that *Arctophila fulva* appears to prefer.

Climate Change

Wetlands are among the most abundant and productive aquatic ecosystems in the Arctic. They are ubiquitous and characteristic features throughout the Arctic and almost all are created by the retention of water above the permafrost (ACIA, 2005). Because the very nature of their habitats results from interactions between temperature, precipitation and permafrost, these Arctic freshwater systems are particularly sensitive to climate change. Aside from habitat provision, river-flow attenuation, and a number of other ecological functions, wetlands also store and potentially release a notable amount of carbon, with potential positive feedbacks to climate change (e.g., radiative forcing by methane – CH₄ and carbon dioxide CO₂ (ACIA, 2005). The role of Arctic and subarctic wetlands as net sinks of sources of carbon is highly dependent on the seasonal water budget and levels; the brief and intense period of summer primary productivity (during which photosynthetic assimilation and respiration of CO₂ and bacterial metabolism and CH₄ generation may be most active); soil type; active-layer depth; and extent of permafrost (ACIA, 2005). The future status of wetlands as carbon sinks or sources will depend on changes in vegetation, temperature, and soil conditions all of which are sensitive to direct and indirect effects of climate change (ACIA, 2005).

3.2.6.2. Threatened / Endangered and Sensitive Plant Species

U.S. Status

No federally-listed threatened or endangered plants are known to occur on the ACP (USFWS, 2014d). The Alaska Natural Heritage Program (AKNHP) maintains a database of rare vascular plant species, which includes global and state species status ranks. Plants ranked as critically imperiled or imperiled in Alaska could occur in the area potentially affected by the Proposed Action. These include eight BLM sensitive species of plants which are known to occur (Cortés-Burns et al., 2009) within the area potentially affected by the Proposed Action for this DEIS:

- Alpine Whitlow-grass (*Draba micropetala*)
- Adam’s Whitlow-grass (*Draba pauciflora*)
- Oriental Junegrass (*Koeleria asiatica*)
- Drummond’s bluebell (*Mertensia drummondii*)
- Arctic poppy (*Papaver gorodkovii*)
- Sabine grass (*Pleuropogon sabinei*)
- Alaskan bluegrass (*Poa hartzii* ssp. *Alaskana*)
- Circumpolar cinquefoil (*Potentilla stipularis*)

Canada Status

The Yukon Territory has one species of Plant that is considered to be at risk under Canadian federal legislation, the Baikal Sedge (*Carex sabulosa*). This threatened sedge grows in active, shifting dune environments of southwest Yukon (Baikal Sedge Recovery Team, 2012). In the Northwest Territories the following plant species are of Global Conservation Concern and could be affected by a very large oil spill (VLOS); they are considered globally rare species that have not yet gone through the process to assess and list under the Canadian North West Territories “Species at Risk (NWT) Act” or the Canadian federal “Species at Risk Act.”

- Hairy Rockcress (*Braya pilosa*)
- Nahanni Aster (*Symphyotrichum nahanniense*)
- Banks Island Alkali Grass (*Puccinellia banksiensis*)
- Raup's Willow (*Salix raupii*)
- Drummond's Bluebell (*Mertensia drummondii*)

Only the Banks Island Alkali Grass occurs near the shores of inland freshwater lakes. Hairy rockcress is endangered; it grows on bluffs and dry uplands on patches of bare, calcium-rich sandy or silty soils. It is endangered by the loss of habitat through very rapid coastal erosion and saline wash resulting from storm surges, and by permafrost melting (COSEWIC, 2013).

3.3. Sociocultural Systems

3.3.1. Sociocultural Systems

3.3.1.1. A Subsistence Focus

Sociocultural systems and rural subsistence practices are inseparable in northern Alaska. Iñupiat peoples comprise the majority of the population in northern Alaska (Hunsinger and Sandberg, 2013). Subsistence substantially contributes to cultural continuity, well-being, identity, and life satisfaction in northern Alaska (Martin, 2012).

Subsistence is a dominant component of Iñupiaq socioeconomics and holds at least equal importance to that of the cash and wage earning sectors; the subsistence and monetary components of these systems have become irrevocably intertwined (Galginaitis, 2014b; Huskey, 2004). Both subsistence and commercial-wage activities contribute to community survival, well-being, and the way of life so highly valued in rural communities (BurnSilver et al., 2016; Huskey, 2004; 2009; Martin, 2012; Wolfe and Walker, 1987). Braund and Moorehead (2004, p. 105) defined “way of life” as the economic, social, and cultural relationships of a group of people and the meanings they attribute to these relationships, including their relationships to natural resources. The subsistence way of life in northern Alaska includes much more than the economics of food production; however, during the late twentieth century to present, the production of wild foods and distribution of wild resources for local consumption and small-scale exchange have been the focus of subsistence activities in rural Alaska (Wolfe, 2009).

For residents of Kaktovik and Nuiqsut, a subsistence way of life and a diverse set of subsistence-related activities, including harvest and sharing of wild resources, comprise the major sociocultural focus of households, families, and hunters (Galginaitis, 2014b; Kofinas et al., 2016; Pedersen et al., 2000; SRB&A, 2010, 2013). Iñupiat peoples living in coastal communities outside the Proposed Action Area also focus on subsistence activities as a dominant part of their cultures and economies. Examples include Utqiagvik and Wainwright to the west and Inuit coastal communities to the east in Canada. It is important to consider coastal communities outside the immediate Proposed Action Area due to the possibility of a VLOS. Oil spills are illegal, unplanned, and accidental events. Although not part of the Proposed Action, a VLOS has the potential to affect sociocultural systems (Section 3.3.1), economy (Section 3.3.2), subsistence activities (Section 3.3.3), community health (Section 3.3.4), and environmental justice communities (Section 3.3.5) outside the immediate Proposed Action Area.

Using a subsistence lens, this section summarizes important components of the sociocultural system in northern Alaska that could be affected by the Proposed Action.

3.3.1.2. Components of the Sociocultural System

Sociocultural systems generally encompass several principal components (Elwell, 2013; Wolfe, 1983). In the context of rural Alaska, a social, cultural, or economic system is a set of interacting, interrelated, or interdependent parts that form a collective whole (Wolfe, 1983). A breakdown in any part of the system can cause social disruptions, community dysfunctions, and economic hardships (Wolfe, 1983).

There have been substantial social, economic, and technological changes in the Iñupiaq way of life during the past century related to energy development and other contacts and interactions with people arriving from outside the North Slope (BurnSilver et al., 2016; Carothers, Cotton, and Moerlein, 2013; Kruse, 1982; Langdon, 1996; Martin, 2012). However, subsistence continues to be the visible central organizing element of Iñupiaq sociocultural systems (Kofinas et al., 2016; USDOJ, MMS, 2001, 2002), and it is primarily through damage to subsistence resources and disruptions to subsistence activities that impacts to the sociocultural system of the North Slope can be assessed.

The next paragraphs briefly describe three key organizing and interrelated parts of the sociocultural system for Nuiqsut and Kaktovik. Using the umbrella of subsistence, the discussion focuses on social organization, cultural values, and formation of formal institutions (USDOJ, BOEM, 2015). The description of these elements generally applies to Nuiqsut, Kaktovik, Utqiagvik, and other northern coastal communities in Alaska and Canada. These components of the system are closely tied to the mixed subsistence-cash economy of northern Alaska and could be affected by the Proposed Action.

Social organization means how people are divided into social groups and networks. This component of the system corresponds most closely to existing structure at the household and community levels. Structure refers to how key individuals, families, and extended kinships interact to manage vital

resources, which includes subsistence harvests but also encompasses many economic resources and involves the broader market economy (Huskey, 2004). The analytic focus is on households, families, and wider networks of kinship and friends that are embedded in groups responsible for harvesting/collecting, distributing, and consuming available local resources. Social organization describes the nongovernmental characteristics of a community that enable it to function and continue through time. For most Alaska Native peoples living on the North Slope, subsistence is the expression of cultural and spiritual identity (ICAS, 1979), and production, distribution, and sharing of subsistence foods are the activities around which most social organization and transmission of cultural traditions occur across generations.

Cultural values reflect the norms and most desirable behaviors of people in a society and are widely shared by members of a social group. Cultural values correspond to the Iñupiat traditional emphasis on maintaining a close relationship with natural resources (ICAS, 1979). They place particular emphasis on kinship, maintenance of the community, spirituality, humility, respecting elders, hunting traditions, cooperation, and sharing (ICAS, 1979; NSB, 2015). Differences in sociocultural systems and cultural values between outsiders and local residents can lead to substantial communication barriers (Bartely, Brooks, and Boraas, 2014; EDAW AECOM, 2009; Jacobs and Brooks, 2011). Residents of the Proposed Action Area place high value on social cohesion and group cooperation as expressed through subsistence activities (ICAS, 1979). Subsistence is a central activity that embodies and actualizes all Iñupiaq values, with bowhead whale hunting being the paramount offshore subsistence activity for Nuiqsut, Kaktovik, and Utqiagvik. Iñupiaq cultural and spiritual values are played out in everyday life when these residents practice subsistence activities on the land (Galginaitis, 2014a; ICAS, 1979).

Institutional formation corresponds to the structure and function of the borough, city, and tribal governments that provide services to communities. This part of the system includes formal organizations such as the North Slope Borough, Alaska Native regional and various village for-profit and not-for-profit corporations and nongovernmental organizations. Many Iñupiat are enrolled as shareholders in the for-profit Native corporations, and they are citizens of the North Slope Borough, which derives revenues from property taxes on petroleum facilities at Prudhoe Bay (ICAS, 1979). Nongovernmental entities may work in conjunction with governmental organizations. For example, the AEWC and other local or regional organizations play important roles in the management of natural resources vital to the subsistence and cultural needs of the communities. These formal institutions are largely formed by Alaska Native peoples who are aware of and respect traditional knowledge of their elders and have a present-day awareness of their own beliefs and cultural foundations. Many of the leaders of these institutions currently live or have lived a rural subsistence way of life and have a clear understanding of why and how to protect subsistence resources.

3.3.2. Economy

This section describes the existing conditions of the economy of the State of Alaska, NSB and Prudhoe Bay with respect to employment, personal income associated with employment, various types of revenue streams, and population. Additional information about the economy of the NSB and its communities is available in the 2015 Liberty EIA (Hilcorp, 2015, Appendix A). All of the numbers that BOEM presents in this section are approximate.

3.3.2.1. Employment and Labor Income (Wages)

Table 3.3.2-1 provides information on total employment and labor income (wages) for Alaska, the NSB, and Prudhoe Bay in 2015, as well as information on the percentage of employment that represents government jobs.

Table 3.3.2-1. Employment and Wages for Alaska, NSB and Prudhoe Bay (2015).

Geographic Area	Total Employment (Jobs)	% Government Jobs	Labor Income (Wages)
State of Alaska ¹	310,000	14.3	\$13.6 billion
NSB ¹	3,360	60	\$151 million
Kaktovik ²	130	74	
Nuiqsut ²	190	59	
Prudhoe Bay ³	12,550	0.0	\$1.39 billion

Sources: ¹ADLWD, 2015d; ²ADLWD, 2015b; ³ADLWD, 2015a.

Alaska Employment and Wages

Oil is a critical resource for the U.S. economy, and North Slope oilfields produced an average of 20% of the nation's domestic production between 1980 and 2000. Oil production from the North Slope started in the late 1970's, peaked in the late 1980's, and has continued to decline since. With the Trans-Alaska Pipeline System (TAPS) now running at three quarters empty, Alaska's share of domestic oil production has fallen to 7%, and the State has fallen from second to fourth in U.S. oil production (RDC, 2017).

Although the oil and gas industry employs less than five percent of all Alaska workers, it has driven much of the growth in Alaska's economy for the past 40 years. Oil production (not including support activities) has directly accounted for a quarter of total gross State product, and approximately one-third of all jobs and personal income in Alaska can be traced to work in oil production-related activities, spending of the State's oil revenues, or the Permanent Fund dividend (Goldsmith, 2007). Moreover, oil and gas industry wages are roughly 2.5 times higher than average annual wages for all industries in the State combined (ADLWD, 2013). Since 2007, however, the relative contribution of the oil and gas industry to the State economy has declined due to lower oil and gas prices and reduced throughput of oil in TAPS.

NSB Employment and Wages

As shown in Table 3.3.2-1, there were approximately 3,360 persons employed in the NSB in 2015, including 2,120 in Utqiagvik (formerly Barrow), 130 in Kaktovik, and 190 in Nuiqsut. Local government, which includes schools, is the top employer of North Slope permanent residents. Nearly 60% of persons employed in the NSB were Borough government employees: 55% in Utqiagvik; 74% in Kaktovik; and 59% in Nuiqsut (ADLWD, 2015b). The high percent of local government employees in the NSB is in contrast to the State of Alaska (14.3%) and the U.S. (3.8%). Property tax payments by North Slope oil and gas producers are the main source of revenue for the NSB and directly support this high percentage of local government jobs (AOGA, 2014). The total wages for workers in the NSB in 2015 was approximately \$151 million (ADLWD, 2015b). High unemployment and underemployment are characteristic of communities of the NSB (Hilcorp, 2015, Appendix A).

Only five residents of the NSB worked in "primary oil and gas companies" and 70 worked in oil and gas support services in Alaska in 2013 (AOGA, 2014). The relatively low share of employment of Borough residents could be in part due to the fact that the job requirements at Prudhoe Bay require certain work schedules that may limit the ability of NSB residents to practice seasonal subsistence. In addition, NSB residents have the option of relatively high paying NSB government jobs with schedules that more easily allow for seasonal subsistence. Training programs and workforce development will continue to be important in the future to increase oil and gas industry employment of local residents. Industry can best address this issue by partnering with the NSB, Arctic Slope Regional Corporation, State of Alaska, community colleges, University of Alaska, vocational technical schools, and job training facilities (Shell, 2011).

Prudhoe Bay Employment and Wages

Prudhoe Bay and the surrounding fields form a worker's enclave within the boundaries of the NSB; the workers are not permanent residents of the NSB. Therefore, the State of Alaska Department of Labor and Workforce Development records Prudhoe Bay employment and wage data separately from that for the NSB. In 2015, the oil and gas industry at Prudhoe Bay provided approximately 12,550 jobs and accounted for \$1.39 billion in annual wages (ADLWD, 2015a). These 12,550 jobs were in the following categories: 74% in oil and gas extraction activities (of which 16% were in crude petroleum and natural gas extraction and 58% were in support activities for oil and gas operations including drilling wells); 14% in professional and business services; and 11% in four other smaller categories (ADLWD, 2015a).

Another aspect of the Prudhoe Bay oil and gas enclave is that workers have almost no integration into the local economy. Infrastructure, work sites, and housing are largely self-contained enclaves, separate from the closest communities of Nuiqsut and Kaktovik (Shell, 2011; AOGA, 2014). The exception is the Kuukpik Hotel in Nuiqsut, which caters to workers at the Alpine field, 8 miles to the south of Alpine. Nuiqsut is 86 miles and Kaktovik 92 miles from Liberty.

3.3.2.2. Revenues

Federal Revenues

The Federal government collects revenues from the production of oil and natural gas on the OCS through bonus bids, royalties, and rents from lessees. Federal revenues reported for all OCS production totaled \$2.79 billion in FY 2016. The U.S. Department of the Treasury distributes about half of the revenues generated from all mineral development in various proportions to the states, the Historic Preservation Fund, the Land and Water Conservation Fund, the Reclamation Fund, and Native American Tribes and Allottees. The other half remains at the U.S. Treasury, helping to fund U.S. programs (ONNR, 2016b).

State Revenues

The State of Alaska receives revenues from oil and gas activities in the form of royalties, property taxes, State corporate income tax, and revenues associated with the TAPS. By FY 2013, it had received \$197 billion in oil revenues since Statehood in 1959 (AOGA, 2014). For over two decades, about 80% of Alaska's unrestricted general fund revenue has come from oil taxation and royalties (Hilcorp, 2015, Appendix A).

In FY 2013, approximately \$7.4 billion in oil revenues collected by the State accounted for 47% of all state revenue and approximately 92% of the state unrestricted general fund (AOGA, 2014). The general fund pays for almost every state service, including education, transportation infrastructure, public health and safety services, and a host of other programs throughout Alaska. Since late 2014, the price of oil has dropped dramatically and the TAPS throughput has dropped further, reducing revenues to the State. The State discontinued personal income and sales taxes in 1978 when Prudhoe Bay production started generating very high royalties for the State. The State is now considering some form of tax because of budget deficits.

In addition, the Federal government transferred \$1.42 million in FY 2016 in royalties, rents, bonuses, and other revenues from OCS leases as provided by Section 8(g) of OCSLA (ONRR, 2016a). It transferred a total of \$94.8 million to the State from FY 2003 through FY 2016 under the same provision. These revenues are from production at Northstar in the Beaufort Sea State waters adjacent to the 3-mile line separating U.S. and State waters. The facility directionally drills from State waters into the OCS resulting in OCS production revenues shared between the U.S. government and the State under Section 8(g) provisions. The \$1.42 million of Section 8(g) revenue represents a relatively small share compared to the \$7.4 billion the State collects from oil and gas royalties within the State.

NSB Revenues

The NSB receives revenues primarily from property taxes on high value onshore oil and gas infrastructure at Prudhoe Bay. NSB property taxes increased from \$307 million in 2011 to \$339 million in 2015 (ADLWD, 2015c). As the depreciable value of oil and gas infrastructure decreases, the revenues accruing to the NSB from oil and gas activities will also decline unless new onshore infrastructure is constructed.

The NSB FY 2015 Operating Budget was \$379 million and the property taxes collected on the oil and gas infrastructure was \$340 million, which represents 90% of the operating budget (NSB, 2017).

3.3.2.3. Population

Table 3.3.2-2 provides 2015 population data for the State of Alaska, NSB, local jurisdictions and Prudhoe Bay (Prudhoe Bay is not a jurisdiction). Oil and gas workers, who regularly rotate in and out of Prudhoe Bay, are not permanent residents of the Borough.

Table 3.3.2-2. Population of Permanent Residents (2015).

Jurisdictions	Population
State of Alaska	737,200
NSB	9,890
Utqiagvik (formerly Barrow)	4,550
Kaktovik	240
Nuiqsut	450
Prudhoe Bay (not a jurisdiction)	-0-

Source: ADLWD, 2015e.

While the overall population of permanent residents of the State and the NSB increased between 2000 and 2012, most of the small communities of the NSB lost population over that time-period (Hilcorp, 2015, Appendix A).

3.3.2.4. Social Cost of Carbon

Federal agencies use the social cost of carbon (SCC) to estimate the climate benefits of rulemakings, although some have begun to use it in their NEPA analyses as well. The SCC is an estimate of the economic damages associated with a small increase in carbon dioxide (CO₂) emissions, conventionally one metric ton, in a given year. This dollar figure also represents the value of damages avoided for a small emission reduction (i.e., estimating the benefit of a CO₂ reduction).

The SCC is meant to be a comprehensive estimate of climate change damages. It includes changes in net agricultural productivity, human health, property damages from increased flood risk, and changes in energy system costs. However, the models used to develop SCC estimates, known as integrated assessment models, do not currently include all of the important physical, ecological, and economic impacts of climate change recognized in the climate change literature because of a lack of precise information on the nature of damages and because the science incorporated into these models naturally lags behind the most recent research. Nonetheless, the SCC is a useful measure to assess the benefits of CO₂ reductions and inform agency decisions.

3.3.3. Subsistence Activities and Harvest Patterns

3.3.3.1. Overview

A primary source of information for this section is Galginaitis (2014b) adopted from the September 8, 2015 Hilcorp EIA (EIA) (Hilcorp, 2015, Appendix A). The discussion focuses on subsistence harvest patterns for Nuiqsut and Kaktovik. The information included in the EIA was reviewed and verified by BOEM, and BOEM has updated and expanded the information. BOEM has added information about Utqiagvik due to the importance of marine mammal hunting and coastal fishing for the residents of

Utqiagvik. The discussion provides greater detail about the bowhead whale hunt launched from Cross Island than whaling in other communities, because it is the subsistence whaling activity closest to the Liberty site (Galginaitis, 2014b). BOEM also relied on information in OCS Study MMS 2009-003 (SRB&A, 2010) and OCS Study BOEM 2013-218 (Galginaitis, 2014a).

For centuries, physical and cultural survival in the Arctic has centered on gathering of subsistence foods and materials and the knowledge needed to harvest these resources. The majority of permanent residents of the NSB are of Iñupiat descent (Hunsinger and Sanberg, 2013; NSB, 2010). Iñupiaq culture, similar to any culture, changes and evolves through time. The Iñupiat pass knowledge and beliefs about subsistence resources and practices from one generation to the next, including observations of animal behavior (NSB, 2010). They do this to successfully locate and harvest fish and game in the present and ensure successful harvests in the future (Spencer, 1976).

The Iñupiat of northern Alaska remain socially, economically, and ideologically loyal to their subsistence heritage and way of life (BurnSilver et al., 2016; Fall, 2016; Galginaitis, 2014a, 2014b; Kishigami, 2013a, 2013b; Martin, 2012; NSB, 2010; USDOI MMS, 2001). In 2010, 66.7 percent of Iñupiat households reported depending on subsistence resources for one half or more of their total diet (NSB, 2010). In Alaska, a subsistence way of life includes substantial amounts of resource sharing and other types of exchanges within and between related kinship groups, families, and households (BurnSilver et al., 2016; Carothers, Cotton, and Moerlein, 2013; Heinrich, 1963; Kishigami, 2013a, 2013b; NSB, 2010; Wolfe and Magdanz, 1993; Wolfe et al., 2009).

For residents of Nuiqsut, Kaktovik, and Utqiagvik, many subsistence activities are practiced and serve a central focus of personal and cultural identity. Subsistence harvests are usually group activities that further the cultural values of community, kinship, respect for elders, and cooperation. Subsistence activities provide social organization and integration and a rich diet that contributes to good health (Kishigami, 2013a, 2013b); subsistence foods, especially the fats therein, are healthier than store-bought foods and reduce the risk of cardiovascular disease (Nobmann et al., 2005). Subsistence harvests provide special foods for religious and social occasions, preserving traditional practices such as the Apugauti (Beaching of the Boats) festival and the Nalukataq (Spring Whaling) festival held to pay respect and honor to the harvested whales and ensure the success of future hunting seasons (Kishigami, 2013a, 2013b). These festivals often include large feasts in which many residents, especially elders, widows, and other persons in need can partake of highly esteemed foods and reaffirm their identities as Iñupiat (Kishigami, 2013a, 2013b). People living in Nuiqsut, Kaktovik, and Utqiagvik give and receive maktak, whale meat, and other subsistence foods and local resources to connect families and communities and maintain ties with family members living far outside these communities (BurnSilver et al., 2016; Carothers, Cotton, and Moerlein, 2013; Kishigami, 2013a, 2013b).

The most visible and easily documented component of subsistence activities on the North Slope is the actual harvest of subsistence resources (Galginaitis, 2014b). Communities tend to harvest local resources most available to them, concentrating efforts along rivers and coastlines and at sites close to town that have proven particularly productive. Two broad subsistence harvest niches (i.e., groupings, mixes) occur on the North Slope and demonstrate how subsistence resources generally co-occur in time and/or space (Galginaitis, 2014b:3): coastal and marine harvesting of whales, seals, waterfowl, fish, and other marine species and terrestrial and aquatic harvesting of caribou, fish, moose, bears, furbearers, small game, and edible roots and berries. Kaktovik, Nuiqsut, and Utqiagvik depend on resources from each of these groupings with marine mammals, especially bowhead whales, caribou, and fish being the primary resources harvested. Various types of ice seals and migratory waterfowl play important roles at certain times of the year. The communities differ in their overall subsistence harvest patterns.

Global climate change is already having immediate impacts on Alaska Native peoples and other indigenous communities in the Arctic (Becker, 2011; Parson et al., 2001). For the North Slope, BOEM anticipates increases in temperature, sea level, rain, and ocean acidification and decreases in snow extent, permafrost, and sea ice coverage and thickness (Section 3.1.6). Climate change in the NSB has adversely impacted the timing of wildlife migrations, access to subsistence resources, failure of village infrastructure, erosion of village lands, and loss of food storage capacity related to permafrost thawing and failing ice cellars (ANTHC, 2014; NSB, 2014, 2015).

Hunters from Utqiagvik and Kaktovik have noted more bowhead whales during recent decades; however, less multi-year sea ice and thinner shorefast ice has made it difficult for whalers to find ice on which to haul whales out for butchering in spring (Huntington, Quakenbush, and Nelson, 2016, p. 2). In this study, hunters reported travelling on sea ice for hunting is more dangerous and limited now, because shorefast ice is thinner, less extensive, and no longer anchored by multi-year ice.

Some effects of global climate change during the next 25 years may be beneficial for subsistence hunters. For example, rising water levels in rivers are projected, which most likely would improve and extend upriver and downriver access to important subsistence harvest areas and resources such as caribou, moose, and freshwater fishes (Huntington, Quakenbush, and Nelson, 2016). Whalers living in Nuiqsut rely on boat travel down the Colville River to access Cross Island and their traditional whaling area.

As described in Section 3.1.6, global climate change is projected to have many and varying effects in Arctic Alaska in the foreseeable future, and some changes in baseline environmental and social conditions could become more evident during the life of the Proposed Action. The current conditions in the Proposed Action Area would most likely change during the 25-year life of the Proposed Action. The extent and degree of changes to subsistence hunting and fishing in this relatively short time frame are somewhat uncertain and speculative. For example, subsistence hunters have emphasized that effects on marine mammals and people are the result of interactions among multiple factors, not of changing sea ice alone (Huntington, Quakenbush, and Nelson, 2016, p. 3). Hunters have been able to adapt to some of these changes by improved equipment and changes in the timing of hunting, and marine mammals appear to be adjusting to a longer open-water period (Huntington, Quakenbush, and Nelson, 2016).

3.3.3.2. Subsistence Communities

The Proposed Action Area encompasses lands and waters traditionally and presently used for subsistence harvests by residents of Nuiqsut and Kaktovik (Figure 3.3.3-1; Galginaitis, 2014b; Pedersen, 1979; SRB&A, 2010). Nuiqsut is approximately 80 miles west of the proposed LDPI, and Kaktovik is approximately 94 miles east of the proposed LDPI (Galginaitis, 2014b). BOEM describes details of relevant subsistence resources in relation to each community.

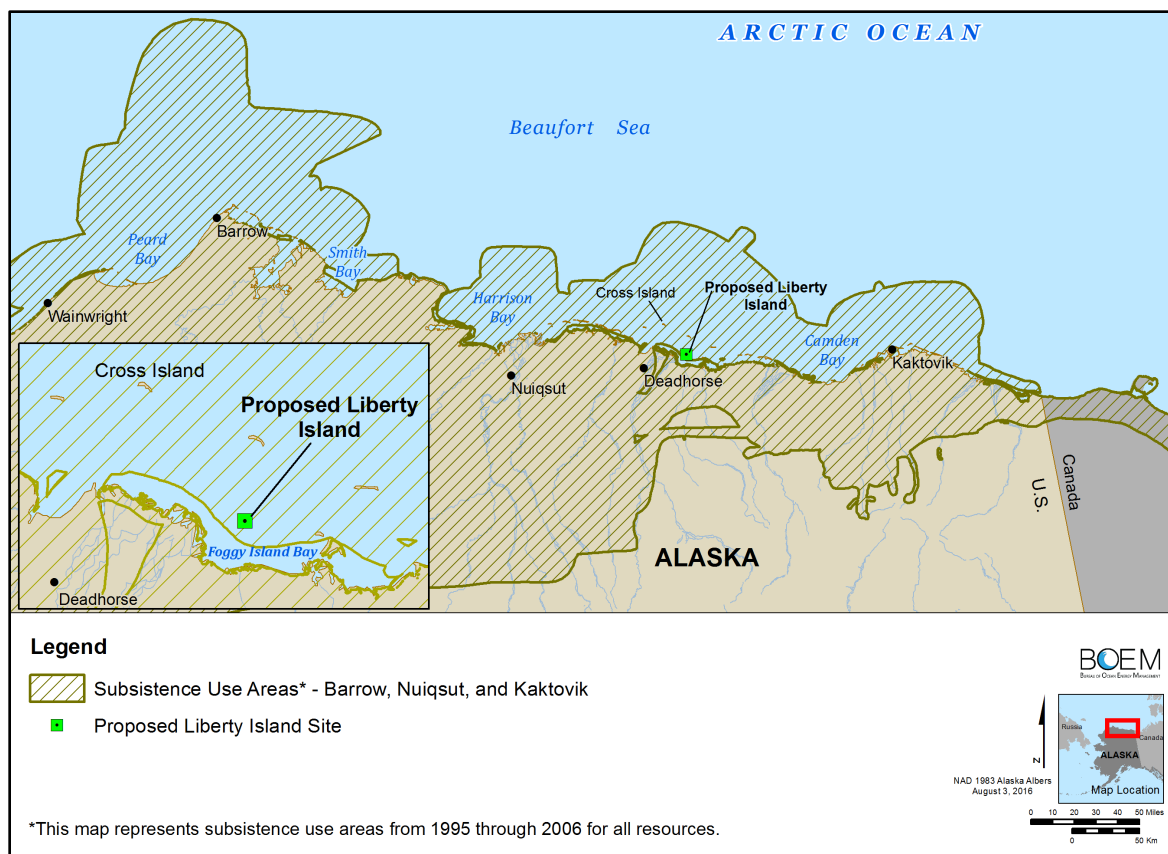

Figure 3.3.3-1. Subsistence Use Areas for Utqiagvik, Nuiqsut, and Kaktovik. Subsistence use areas were derived from interviews with active and knowledgeable subsistence harvesters in the following communities: 75 harvesters in Utqiagvik, February, March, April, and December 2006; 33 harvesters in Nuiqsut, November 2004, November 2005, and November, December 2006; 38 harvesters in Kaktovik in June 2005, November 2005, and November 2006. Source: Stephen R. Braund & Associates (2010) in coordination with the North Slope Borough Department of Wildlife Management, local tribal governments, and local subsistence harvesters.

The areas for Nuiqsut's bowhead whaling, Kaktovik's caribou hunting, and the Arctic cisco subsistence fishery in the Colville River are discussed in greater detail than other subsistence resources. These three subsistence resources are critical to maintaining the sociocultural system and are considered most proximate to the Proposed Action Area and may overlap with it to the greatest extent at various times of year due to normal movement patterns exhibited by these species. Many of the marine mammals, birds, fish, and caribou harvested by Nuiqsut and Kaktovik in areas and places outside the Proposed Action Area migrate through and/or use the Proposed Action Area for habitat (Galginaitis, 2014b; NOAA, 2014). Changes or disruptions to these migratory resources could potentially affect subsistence harvesters in Nuiqsut and Kaktovik and in places farther from the Proposed Action Area such as Utqiagvik to the west and Inuvialuit communities near the Mackenzie River delta to the east.

Nuiqsut

The city of Nuiqsut is located about 12 miles inland on the Colville River, which is navigable for a substantial distance. It is located in the midst of numerous oil company facilities and industrial developments. In 1973, 27 Iñupiat families moved back to Nuiqsut from Utqiagvik; in 1974, the Arctic Slope Regional Corporation funded construction of the community. The population of Nuiqsut in 2010 was about 415, and about 92 percent were Alaska Native peoples (NSB, 2015a). Nuiqsut generally has more of a terrestrial orientation than Kaktovik (Galginaitis, 2014b). The Colville River provides access to the ocean, however, and residents of Nuiqsut do rely on the harvest of marine

mammals. Nuiqsut hunters go looking for bowhead whales offshore from camps on Cross Island starting in late August and ending in October (Galginaitis, 2014a, 2014b). Belugas are not a prevailing subsistence resource for Nuiqsut (NOAA, 2014:24). Caribou are hunted throughout the year by residents of Nuiqsut, but June through September are the predominant months for caribou hunting, using boats along the coast and the Colville River (Table 3.3.3-1; SRB&A, 2010). Nuiqsut hunters use coastal areas around the Colville River delta to harvest geese and sea ducks (SRB&A, 2010). Residents of Nuiqsut primarily go fishing inland in the Colville River for Arctic cisco and other species. Moose are important for subsistence to residents of Nuiqsut, but are primarily hunted inland along the Colville River south of town (SRB&A, 2010). Galginaitis (2014b) and Pedersen (1996) reported Nuiqsut's overall total subsistence harvest almost equally divided among marine mammals (32%), terrestrial mammals (33%), and fish (34%).

Kaktovik

The city of Kaktovik is located on Barter Island and has no nearby rivers that are navigable for any great distances. The community is on the northern edge of the 20-million-acre Arctic National Wildlife Refuge. In 2010, there were about 308 residents, and over 88 percent were of Alaska Native decent (NSB, 2015b). Kaktovik is generally considered to be oriented toward harvests of coastal and marine resources (Galginaitis, 2014b). Inland terrestrial resources also play important roles in the annual round of subsistence activities of Kaktovik (Table 3.3.3-1; Jacobson and Wentworth, 1982; SRB&A, 2010). Kaktovik hunters go for bowhead whales offshore in September and hunt for caribou throughout the year but primarily in July and August on the coastline and barrier islands (Huntington, 2013; Koski et al., 2005; SRB&A, 2010; Wolfe, 2013). Seals are important to residents of Kaktovik and are hunted offshore and in coastal areas April through September (SRB&A, 2010). Researchers documented that beluga whales did not play a major role in the annual subsistence round for Kaktovik were occasionally harvested during the bowhead season in September (Jacobson and Wentworth, 1982; Frost and Suydam, 2010; NOAA, 2014). However, Kofinas et al. (2016, p. 71, 126) found beluga to be a core subsistence species harvested and shared in Kaktovik; the communal hunt takes place near the village outside the Proposed Action Area and thus is not analyzed in Chapter 4. The residents of Kaktovik use coastal areas and rivers to fish for Arctic char and Arctic cisco in July and August and hunt geese and sea ducks May through September (Pedersen, 1990a; SRB&A, 2010). For Kaktovik, 59 to 68 percent of the total subsistence harvest has historically consisted of marine mammals, 17 to 30 percent terrestrial mammals, and 8 to 13 percent fish (Galginaitis, 2014b; Pedersen, 1996).

Utqiagvik

The town of Utqiagvik (previously Barrow) is the largest permanent community on the North Slope and serves as the administrative and commercial hub of the region. It is a traditional Iñupiaq settlement and the largest employer in the NSB, with numerous residents and businesses providing support services to oil field operations (NSB, 2010, 2015c). In 2010, the population of Utqiagvik ranged from 4,212 to 4,974 and 61 to 68 percent were Alaska Native peoples (Norris, Vines, and Hoeffel, 2012; NSB, 2015c). Subsistence whaling, caribou hunting, and fishing are important to the economy (Table 3.3.3-1; Schneider, Pedersen, and Libbey, 1980; SRB&A, 2010), and many residents with full- or part-time jobs continue to hunt and fish for food and sociocultural identity (NSB, 2015c). Whaling crews from Utqiagvik go for bowheads April through May and September through October in offshore areas, using boats and various other types of equipment (Kishigami, 2013a, 2013b; SRB&A, 2010). Utqiagvik residents primarily hunt caribou in coastal areas by boat July through September and fish for Arctic char, Arctic cisco, and broad whitefish at coastal sites and inland waters June through December (SRB&A, 2010). Residents of Utqiagvik use coastal areas for hunting eiders April through October and geese in May (SRB&A, 2010). Other marine mammals are important for subsistence in Utqiagvik, including ringed seals throughout the year (pursued by boat or on ice with snowmachines); and bearded seals and walrus, pursued June through August offshore by

boats (SRB&A, 2010). Beluga whales play a minor role in the subsistence economy of Utqiaġvik and are generally harvested incidental to whaling or fishing (Frost and Suydam, 2010; SRB&A, 2012). For calendar year 1992, Fuller and George (1997) reported Utqiaġvik’s overall total subsistence harvest approximately divided among marine mammals (72%), terrestrial mammals (19%), fish (7%), and birds (2%).

Table 3.3.3-1. Utqiaġvik, Nuiqsut, and Kaktovik Subsistence Resources and Peak Harvest.¹

Resource Group	Subsistence Resource	Utqiaġvik	Nuiqsut	Kaktovik
Marine Mammals	Bowhead Whale	April – May & September – October	September	September
Marine Mammals	Bearded Seal	June – August	June – September	July – September
Marine Mammals	Ringed Seal	June – August	June – August	June – September
Land Mammals	Caribou	July – September	June – September October – February	April July – August
Fish	Broad whitefish	July – November	June – August October	July – September
Fish	Arctic cisco	July – November	October – November	July – August
Fish	Arctic char	July – September	August – September	April July – August
Migratory Waterfowl	Geese	May – June	April – May	May – June August – September
Migratory Waterfowl	Eider ducks	April – October	June – August	May – June

Note: ¹ Peak Harvest Season = months of harvest effort for the last ten years (1996-2006) measured as highest number of subsistence use areas reported by month (SRB&A, 2010).

Sources: SRB&A, 2012; Galginaitis, 2014b; Jacobson and Wentworth, 1982.

3.3.3.3. Subsistence Resources

Bowhead Whales (*Aġviq*)

The whaling tradition of the Iñupiat people is essential for their continued cultural and social identity. Bowhead whales and the relationship between whales and people are afforded special significance.

“A bowhead whale is a special entity to the coastal Iñupiat people. The Iñupiat people believe that a whale has the capability to see and hear what is happening in human society from far away ... a whale gives itself to a whaling captain and his wife who are generous and kind both to other people and to the whale. A whaling captain’s wife is thought to attract whales ... for her husband’s whaling crew. Thus whaling captains and their wives try to behave or speak properly so as not to threaten or bother whales ... they share their game with others and help those in trouble or need” (Kishigami, 2013:114-115).

The bowhead whale harvest is highly important in Nuiqsut, Kaktovik, and Utqiaġvik (Galginaitis, 2014a, 2014b; Long, 1996; SRB&A, 2010). Hunting bowhead whales provides a cultural and spiritual foundation for sharing and community cooperation (Ahmaogak, 1989; Kishigami, 2013). The bowhead hunt serves an important function as an organizational framework for community events throughout the year and a significant portion of the total community subsistence harvest in typical years. Bowhead whaling strengthens family and community ties, and provides a sense of common heritage in Iñupiaq society (Galginaitis, 2014a; Kishigami, 2013a, 2013b; USDO, MMS, 1998).

For Nuiqsut residents, bowhead whales are a major subsistence resource (Galginaitis, 2014a, 2014b). Bowhead whales are the most critical subsistence resource in terms of importance for maintaining an intact sociocultural system. The Nuiqsut subsistence bowhead hunt is launched from a base camp about 100 miles (160 km) away from the village on Cross Island, which lies approximately 18 statute

miles (29 km) north to northwest of the proposed LDPI (Figure 3.3.3-2; Galginaitis, 2014b). Cross Island is close to the migration path for bowhead whales and is a traditional and historic whaling site.

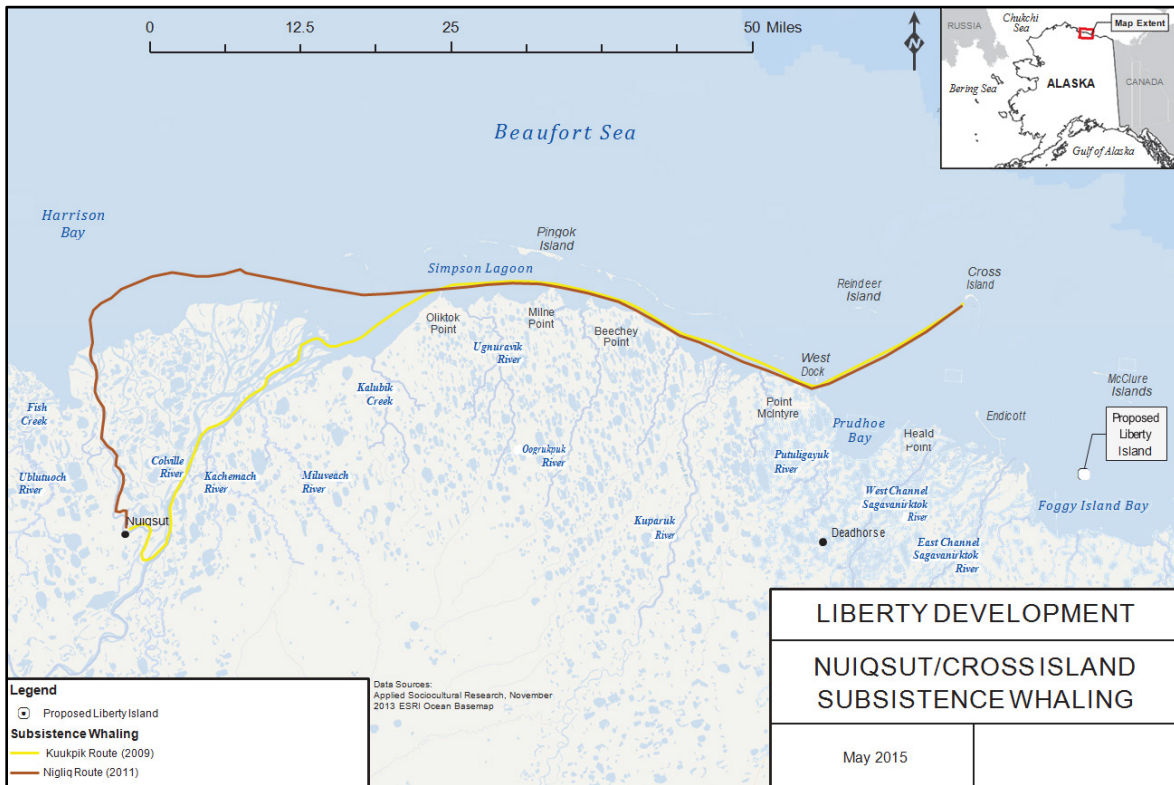

Figure 3.3.3-2. Nuiqsut/Cross Island Location and Travel Routes with Landmarks (*Applied Sociocultural Research, 2013*).

Figure 3.3.3-3 depicts whale sightings in the Cross Island area for 2001 through 2012. Historically, the hunt occurred around the start of September through mid-October. Recently documented seasons in 2001 through 2013 have lasted two to three weeks from late August through mid-September with relatively little ice but frequent adverse weather conditions and large storms. There is a winch on Cross Island that is used to pull whales up on shore for butchering. Nuiqsut crews at Cross Island use trailers and other structures as cabins.

Nuiqsut hunters' current quota is four strikes whether the animals are landed or not. Not all days are equally good for whaling, and there are periods when crews do not go out because of wind and waves (Galginaitis, 2014b). Whales are not reliably found in the same locations from one year to the next near Cross Island. The hunt is largely cooperative in nature. When whales are spotted, the boats are coordinated to intercept them in such a way that at least one crew should have a good shot at striking a whale. Until a whale is spotted, however, crews may independently scout for whales. There is some competition to be the first to strike a whale (Langdon, 1996), as this increases the prestige of that captain and his crew. Once a whale is struck, all crews in the area go to help procure the whale, haul it back to Cross Island, and process the animal into food and other useable products.

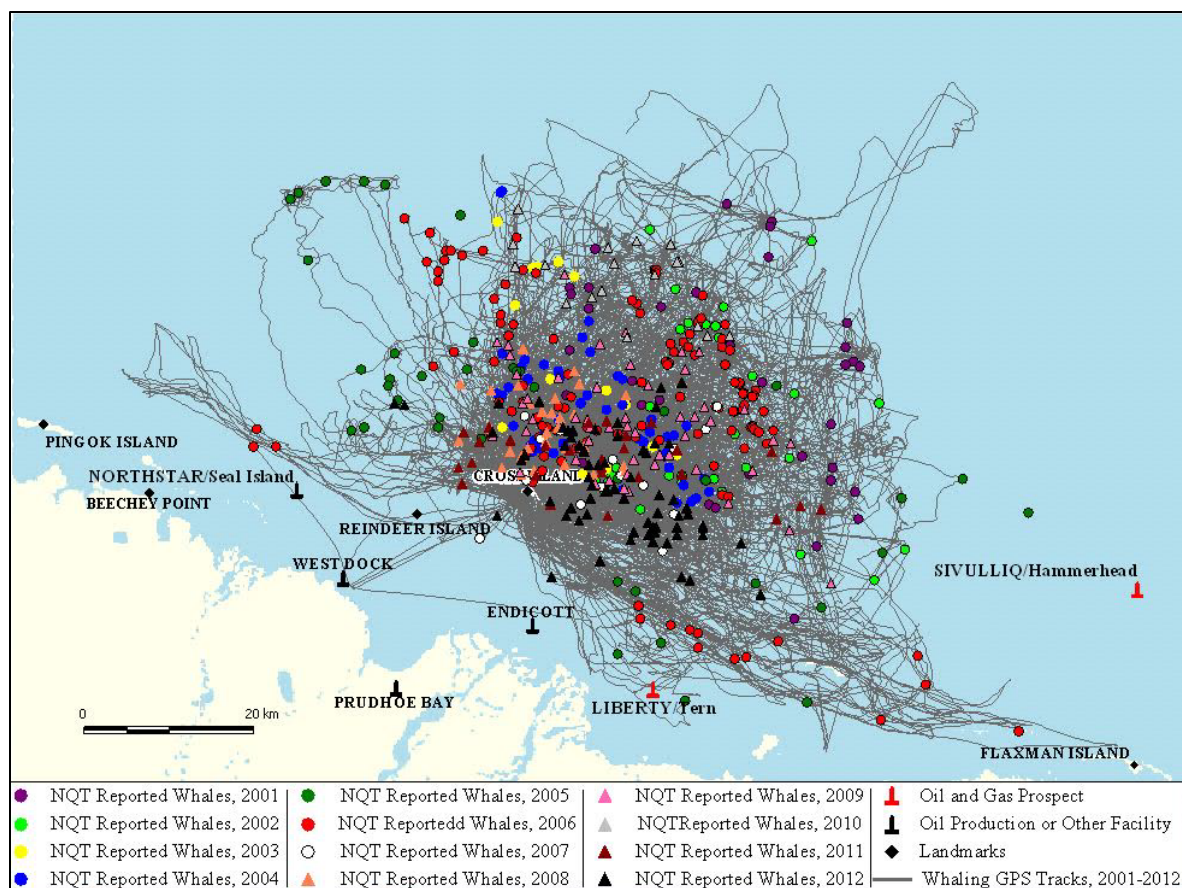

Figure 3.3.3-3. Bowhead Whale Sightings in the Vicinity of Cross Island. Reported by Nuiqsut Whalers (NQT), 2001-2012. Bowhead whale sightings made during scouting and hunting trips by whaling crews from Nuiqsut with GPS tracks of whaling boats (Galginaitis, 2014a, p. 85-86).

Nuiqsut crews do their whale hunting immediately north of the Proposed Action Area, and in some years have scouted for whales directly in the Proposed Action Area (Galginaitis, 2014a, 2014b). The general Nuiqsut harvest area for bowhead whales is located off the coast between the Kuparuk and Canning rivers. The whalers think of this area as bounded by the farthest distance from which they would be willing to tow a whale back to Cross Island. During 2001-2012, the majority of bowhead whales harvested by Nuiqsut hunters were located north to northeast of Cross Island (Galginaitis, 2009, 2014a; USDO, BOEMRE, 2011b; SRB&A, 2010). All of their documented whale strikes have been within an area extending from about the Northstar unit in the west to Bullen Point in the east. Nuiqsut crews have landed most of their whales in a smaller area from five miles west of Cross Island to about 30 miles east of Cross Island (Figure 3.3.3-4; Galginaitis, 2009, 2014a, 2014b; SRB&A, 2010).

This smaller area is most likely the core Nuiqsut whaling area (Galginaitis, 2014a, 2014b). Some Nuiqsut whaling captains will set the eastern boundary as the Canning River/Flaxman Island area or even mid-Camden Bay. For logistical reasons however, it would be unusual for a captain under current operating procedures to strike a whale outside of the smaller core area. Once a whaling captain reaches about 20 miles (32 km) from Cross Island, he starts to consider the length of the tow back should he strike a whale. Only when whalers cannot find whales closer to Cross Island than 20 miles do they look and strike at farther distances (Galginaitis, 2014a, 2014b; Huntington, 2013). Maps indicate that the Nuiqsut whaling area extends east to Kaktovik (Pedersen 1986; SRB&A 2010, 2011). This reflects one year in the 1980s when conditions were too poor to whale from Cross Island and Nuiqsut whalers continued on to Kaktovik and whaled from there with Kaktovik crews.

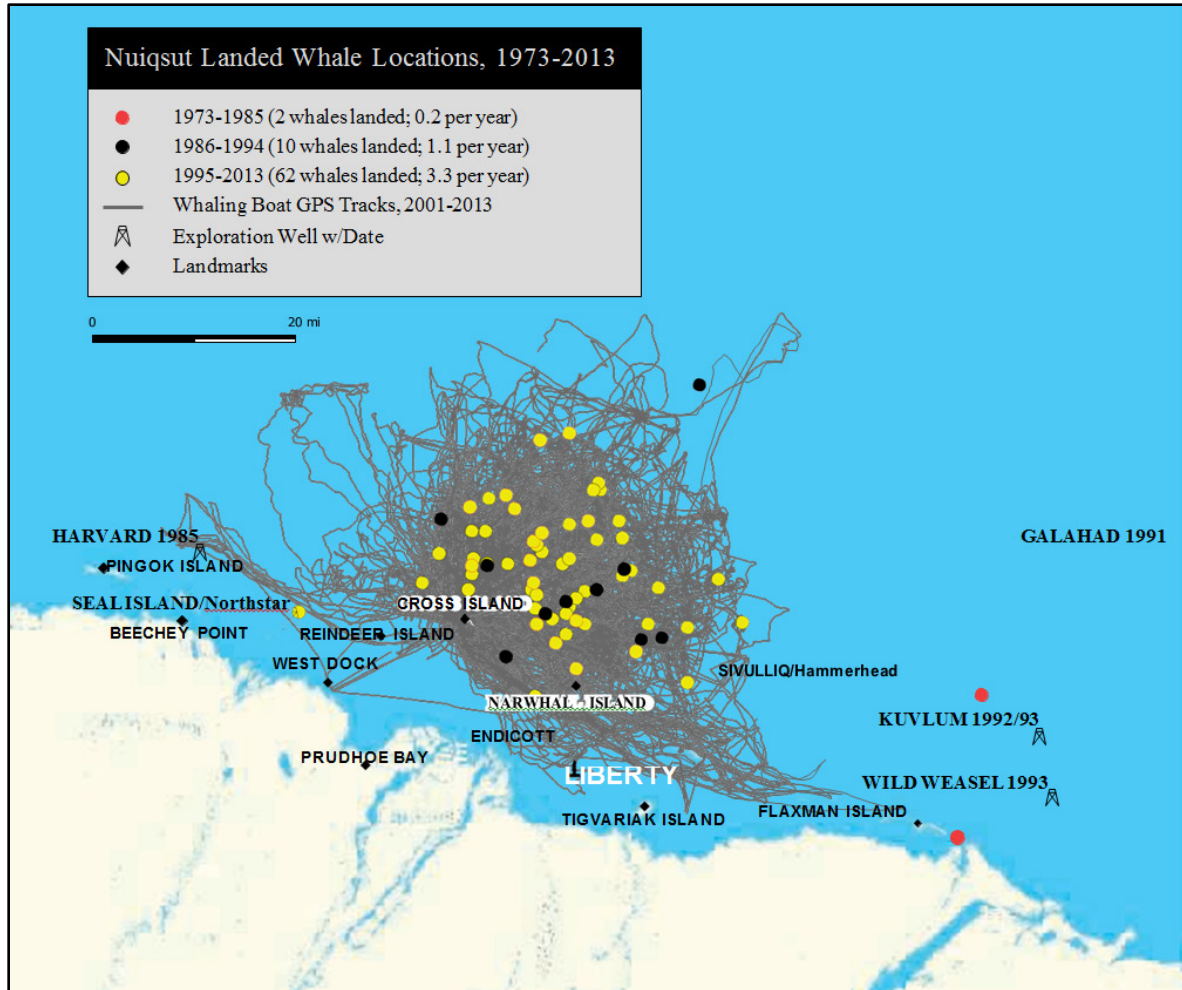

Figure 3.3.3-4. Nuiqsut Landed Whale Locations 1973-2013. Data displayed using aggregated global positioning system whaling tracks 2001-2012 (Galginaitis, 2014b).

Residents of Kaktovik participate in whaling for bowhead in September, sometimes travelling up to 50 miles offshore to harvest whales (SRB&A, 2010). Whaling crews from Kaktovik generally reported travelling between Camden Bay to the west and Nuvagapak Lagoon to the east in search of bowhead whales (SRB&A, 2010). The extreme limits of the Kaktovik whaling area are the middle of Camden Bay in the west and just north of the Kogotpak River in the east. This is as far as Kaktovik whalers can conceive of trying to tow a whale back to Kaktovik (Galginaitis, 2014b). The western edge of this area is about 65 miles east of the Proposed Action Area. The core whaling area for Kaktovik is from the Okpilak and Hulahula rivers in the west to what is labeled Tapkaurak Point on the U.S. Geological Survey base map in the east, farther from the Proposed Action Area. The core area extends out as far as 20 miles from the coast, although most of the time crews will stay within approximately 12 miles of shore. Nearly all whales harvested since 1964 have been struck within this core area (Kaleak 1996; Koski et al., 2005). The farther away from Kaktovik a whale is killed the longer the tow will be, and there is a greater chance that at least part of the meat will spoil.

There are over fifty whaling captains in the community of Utqiagvik (SRB&A, 2010). The spring hunt (April-May) is conducted using skin-covered boats called umiaqs; spring whaling is ice-based and snowmachines are also used in these bowhead hunts (Kishigami, 2013). The spring bowhead hunt generally occurs west of Point Barrow and closer to shore, while fall hunting occurs September through October both west and east of Point Barrow and sometimes greater than 20 miles offshore

(SRB&A, 2010, 2012). The fall hunt is shore-based using metal boats equipped with outboard motors (Kishigami, 2013). Residents of Utqiagvik reported hunting bowhead whales almost as far as Smith Bay to the east and as far as Skull Cliff to the west during the fall season (SRB&A, 2010). The core area for bowhead whaling used by crews from Utqiagvik is located up to 20 miles offshore between the Walakpa River to the west and Cooper Island to the east (SRB&A, 2010).

Ringed Seals (*Natchiq*) and Bearded Seals (*Ugruk*)

In the past 13 whaling seasons, two or three bearded seals have been taken; a few smaller seals were taken for consumption by the whalers during the hunt, and the ugruk were butchered and sent back to Nuiqsut (Galginaitis, 2014a; Huntington, 2013). Nuiqsut residents use bearded seal meat and oil for its nutritional value, and hunters harvest ringed and bearded seals in the Beaufort Sea during the open water season. Seal hunting activity peaks in July and continues through September for Nuiqsut hunters.

Subsistence use areas for ringed seal are located west from Cape Halkett, east to Camden Bay, and up to approximately 20-25 miles (32-40 km) from shore, with some hunters traveling up to 40 miles (64 km) offshore near Thetis Island (SRB&A, 2010). Hunting of ringed seals occurs in open water near the ice pack as seals follow the ice. Less sea ice in the future may affect seal behavior and availability for subsistence harvest. The specific patterns of seal hunting may change during the 25-year life of the Proposed Action. For Nuiqsut hunters, bearded seal hunting occurs between Harrison Bay and Flaxman Island with a high number of hunts occurring between the mouth of Fish Creek and Thetis Island. Hunting occurs up to 20 miles offshore (32 km) extending as far west as Cape Halkett eastward to Camden Bay, and sometimes up to 40 miles offshore (64 km) (SRB&A, 2010).

Nuiqsut hunters currently harvest fewer seals than in the past (Galginaitis, 2014b). An exception is for bearded seals, which are larger than other seals. Seal oil is still an important condiment in almost all households, and bearded seals are preferred for making seal oil, and the meat is highly prized. A small number of families with a maritime orientation catch most of the seals. There is fairly good agreement among informants that the prime sealing area is just north of the Colville River delta and centered on Thetis Island, which is the most commonly used base camp for this area (Galginaitis, 2014b; SRB&A, 2010). This core area extends as far west as Fish Creek and as far east as Pingok Island. Other sites used as base camps in this area are the Spy Islands and Pingok Island. Some people in 1990 indicated that they sealed as far west as Atigaru Point, which they used as a base camp, and as far east as the Cottle/Long Island area. They would seal in these areas before break-up by snow machine. Now, most seal hunting is in June through September by boat and concentrates on ugruk. Seal hunters and families reported camping for up to two weeks on the more eastern islands in 1990; these would be multi-purpose trips and caribou and other subsistence resources would be taken if and when they were encountered (Galginaitis, 1990a). This pattern is no longer evident, and Nuiqsut hunters tend to take seals more locally near Thetis Island and the Colville River delta during open-water periods.

For Kaktovik, informants did not provide much specific information about where they hunt seals in 1990 (Galginaitis, 1990b). Jacobson and Wentworth (1982, p. 54) identified the most intensively used sealing area as Pokok Lagoon in the east to Collinson Point near the Canning River to the west, which is 62 miles east of Foggy Island Bay and the Proposed Action Area. Historically, Kaktovik residents reported hunting bearded seals along the coast as far west as Prudhoe Bay and as far east as the Canadian border (SRB&A, 2010).

Residents of Kaktovik have indicated that ringed seal hunting is less common than in the past because there are so few sled dogs, and people used to use ringed seal for dog food (SRB&A, 2010). Ringed seal are usually harvested in conjunction with looking for bearded seals. Ringed seals are usually harvested by boat or snowmachine during March through September. Most harvests occur after the ice breaks up in July and through August. Bearded seals remain an important source of food for many

Kaktovik residents, and they are generally harvested in the same areas as ringed seals. Hunters have traveled as far offshore as 30 miles (48 km) in search of bearded seal but prefer to hunt them closer to shore up to 5 miles (8 km) off the coast (SRB&A, 2010). Kaktovik hunters can take seals in many places, and as efficient hunters they most commonly take them close to the village. If they encounter seals farther from the village they will harvest them if logistics allow. All recently documented seal harvest for Kaktovik is east of the Proposed Action Area (SRB&A, 2010). For Kaktovik, hunting for bearded seals begins in March and ends in September.

Bearded seal is an important resource for residents of Utqiagvik, providing meat and oil for food and skins for building umiaqs used during spring whaling (SRB&A, 2010). Informants indicated that bearded seals follow the ice pack north during their summer migrations, and their availability to subsistence hunters depends on the year's ice conditions. Utqiagvik subsistence hunting of bearded seals primarily occurs by boat May through September between Skull Cliff and Point Barrow and over 20 miles (32 km) offshore (SRB&A, 2010). SRB&A (2010) reported a relatively high number of use areas for bearded seal farther from shore, as far west as Peard Bay, and as far east as Ekalugruak Entrance.

During interviews in Utqiagvik, respondents indicated that ringed seals are not harvested in great quantities and are not as important as bearded seals (SRB&A, 2010). A number of respondents did report that they continue to hunt ringed seals during all months as needed, using them for meat and oil, and some said that they hunt for ringed seals while looking for bearded seals. For Utqiagvik, the majority of hunting for ringed seals takes place June through August by boat. Subsistence use areas for ringed seal extend off shore from Peard Bay in the west to beyond Smith Bay to the east. The core area for hunting ringed seals is from Nulavik to Point Barrow and along the coast to Skull Cliff and along the Tapkaluk Islands (SRB&A, 2010).

Walruses (*Aiviq*)

Subsistence walrus harvests on the North Slope can vary by tenfold between years and in some years none are taken (Fuller and George, 1997). Walrus are rarely seen near Kaktovik and are not harvested on any purposive or regular basis (Galginaitis, 2014b; SRB&A, 2010; USDOJ, MMS, 1982). Walrus are rare in the Eastern Beaufort Sea and only harvested by Kaktovik hunters when they present themselves during other hunts in the summer months. Kaktovik hunters reported occasionally hunting walrus offshore primarily north of Barter Island but also in areas west of the village toward Mikkelsen Bay and east near Herschel Island. Fuller and George (1997) indicated a harvest of five walrus for Kaktovik in 1992. Walrus were listed in only one of four previous years when surveys were conducted in Kaktovik (ADF&G, 1995).

Walrus have been rarely encountered by Nuiqsut hunters in the past (USDOJ, MMS, 1982). In two of the last 13 years, Nuiqsut whalers at Cross Island have seen and taken a single walrus (Galginaitis, 2014b). These were considered to be rare encounters. Nuiqsut residents rarely see walrus close enough to the community to hunt them on a regular basis; there is not much on the central and eastern Beaufort seafloor for walrus to eat (Huntington, 2013). Walrus are not purposively hunted near Cross Island because the focus is on whaling, and the noise made by purposively firing weapons at walrus is believed to frighten whales further out to sea (SRB&A, 2010), and thus walrus hunting is not analyzed in Chapter 4.

Polar Bears (*Nanuq*)

For the Iñupiat and the Inuit, polar bears hold substantial cultural significance and symbolism and are worthy of great respect; people of the Arctic had many traditional uses of polar bears (Pokiak, 2013; Russell, 2005). Historically, subsistence hunters have targeted polar bears, particularly in years when polar bears are unusually abundant near communities (Galginaitis, 1990b; Jacobson and Wentworth, 1982; Nageak, Brower, and Schliebe, 1991; USFWS, 2010a; Voorhees et al., 2014). Traditionally, the

majority of polar bears were harvested in late fall and early winter, when bears are in good condition and there is adequate snow cover for tracking bears with dog teams or snowmachines (Russell, 2005; Voorhees et al., 2014).

The Proposed Action Area overlaps with the historical extent of traditional polar bear hunting areas for Nuiqsut and Kaktovik (ADF&G, no date; Pedersen, Coffing, and Thompson, 1985). For Kaktovik, however, the core area for polar bears was closer to the village, extending from the Hulahula-Okpilak River delta on the west to Pokok Lagoon on the east and as far as ten miles offshore (Jacobson and Wentworth, 1982). The relatively few polar bears taken by Nuiqsut hunters are caught primarily at Cross Island during the whaling season. Most polar bears taken at Cross Island are considered nuisance bears, bothering the whaling crews or approaching butchered whales to feed (Galginaitis, 2009b, 2014a, 2014b).

In Kaktovik, bears are occasionally harvested in town near peoples' homes to protect human life and property. This has occurred at times when village-run bear hazing patrols were not operating (USFWS, 2010b). In 2004, the U.S. Fish and Wildlife Service, Office of Marine Mammals began working closely with staff at the Arctic National Wildlife Refuge to expand outreach and education efforts with residents of Kaktovik to address human/bear interactions and to engage local residents in polar bear conservation. A new focus of this partnership has been addressing the increase in polar bear-viewing tourism late July through October at Barter Island and establishing a permitted program for community-based polar bear viewing tourism (USFWS, 2010b, 2015; Wolfe, 2013). Polar bear viewing on Barter Island when bears gather to feed on remains of the bowhead hunt has been formally classified as a sensitive tribal area and activity for Kaktovik (Wolfe, 2013). The bear viewing operations provide employment for local guides and engage local youth in polar bear conservation. Tourism centered on polar bear viewing in Kaktovik is a growing industry, thereby both continuing and expanding the local resource values and cultural relationships associated with polar bears (Dvorak and Brooks, 2013).

There are fewer active polar bear hunters today in northern Alaska than in the past, and the average number of polar bears harvested per active subsistence hunter has decreased compared to previous generations (Voorhees et al., 2014, p. 532). In 1989-1990, North Slope hunters from four villages harvested 24 bears, including one killed in defense of life and property (Nageak, Brower, and Schliebe, 1991). In 2008-2009, subsistence polar bear harvest was recorded to be 19 bears for Utqiagvik, four bears for Kaktovik, and zero for Nuiqsut (USFWS, 2010b). Polar bears are primarily harvested opportunistically during other subsistence pursuits (such as seal hunting), while travelling between villages, or for public safety, not necessarily as a regular source of food, hides, or handicrafts (Jacobson and Wentworth 1982; Russell, 2005; USDOI, MMS, 2002, Volume I, p. III-11; USFWS, 2010b; Voorhees et al., 2014), and thus subsistence polar bear hunting is not analyzed in Chapter 4. See Section 3.2.4, Marine Mammals-Polar Bears for information about harvest and quotas.

Caribou (*Tuttu*)

Caribou are an important subsistence resource for the residents of Nuiqsut, Kaktovik, and Utqiagvik, providing a substantial amount of subsistence foods and other materials for these communities on an annual basis (Braem et al., 2011; Fuller and George, 1997; Galginaitis, 2014b; Jacobson and Wentworth, 1982; SRB&A, 2010). For these three communities, caribou hunting peaks in July and August, tapering off in September (SRB&A, 2010). Summer caribou are generally hunted by boat, along the coastline or shores of barrier islands where groups of caribou congregate for relief from insects and heat.

Hunting for caribou for Nuiqsut occurs throughout the year, with June through September being primary harvest months (SRB&A, 2010). Nuiqsut has hunted caribou from the Beaufort Sea coast south to the foothills of the Brooks Range and from the Sagavanirktok River and Prudhoe Bay in the east to Utqiagvik and Atqasuk in the west (SRB&A, 2010). Nuiqsut hunters conduct their caribou

hunts primarily by boat after the river ice breaks up. The core caribou hunting area for Nuiqsut is primarily along the Colville, Itkillik, Chandler, Anaktuvuk, and Kikiakrorak rivers; along the coast between Atigaru Point and Oliktok Point; and in an overland area surrounding Fish and Judy creeks, and Colville River to the west and Itkillik River to the east (SRB&A, 2010). The Proposed Action Area is spatially near the far eastern extent of the caribou hunting area for Nuiqsut, and operations are proposed for the open water season when Nuiqsut hunters go for caribou along the coast and barrier islands. Specific harvest locations collected by the NSB and ADF&G indicate the primary harvest areas for caribou include the immediate Nuiqsut locality, Colville River delta, Nigliq Channel, and Fish and Judy creeks (Braem et al., 2011; Brower and Hepa, 1998).

Caribou are the staple and most preferred terrestrial mammal in Kaktovik's subsistence diet (Jacobson and Wentworth, 1982; Wolfe, 2013). Kaktovik residents harvest caribou from the Porcupine and Central Arctic caribou herds. The Central Arctic herd to the west of Kaktovik is the focus of the summer hunt because these animals are fatter (Wolfe, 2013). Kaktovik hunters go for caribou year-round, using boats or snowmachines; July and August are the peak months for caribou hunting with boats (SRB&A, 2010). Caribou are generally harvested where they are found, and people prefer to take them close to the community but will travel farther when caribou are not found nearby the community (Galginaitis, 2014b). Kaktovik residents reported hunting caribou along the coast as far east as the Mackenzie River delta in Canada and as far west as the Ikpikpuk River and around the shores of Teshekpuk Lake (SRB&A, 2010). The Proposed Action overlaps temporally and spatially with the far western extent of Kaktovik's subsistence caribou hunting area along the coast and barrier islands.

The primary caribou hunting area for Kaktovik is a smaller core area along the coast between Bullen Point and Demarcation Bay (Galginaitis, 2014b; SRB&A, 2010). Bullen point is approximately two miles east of the Proposed Action Area. Caribou hunters from Kaktovik sometimes hunt in coastal areas west of Arctic National Wildlife Refuge d to Flaxman Island and occasionally farther west to the Shavirovik River and Foggy Island (LGL Alaska et al., 1998; SRB&A, 2010). In most years, hunters from Kaktovik seldom use, or expect to use, this entire area, but it is important to have this larger coastal area available during times when caribou and other important resources are not present near the community or in the core hunting area. The information available indicates that over half the caribou harvested by Kaktovik residents are taken during June through September on the coast (Pedersen and Coffing, 1984; Coffing and Pedersen, 1985; Pedersen, 1990b; Wentworth, 1979; LGL Alaska et al., 1998). Kaktovik hunters also harvest substantial numbers of caribou in April but not as many as in July and August (Pedersen, 1990b; SRB&A, 2010). Kaktovik hunters use coastal sites at both these times of year. Fifty eight percent of the total caribou harvest came from coastal sites in 1987-1988 (Pedersen, 1990b).

Historically, researchers have documented Kaktovik's summer subsistence area extending from the Canadian border to Tigvariak Island west of Mikkelsen Bay, which overlaps with the Proposed Action Area (Pedersen, 1986; Galginaitis, 1990b, 2014b; SRB&A, 2010). Available information on specific locations of caribou harvest is limited and dated for Kaktovik but indicates that current coastal harvest usually takes place no farther west than the Canning River and no farther east than Griffin Point (Pedersen and Coffing, 1984; Coffing and Pedersen, 1985; Pedersen, 1990b). For the years 1981 through 1988, Kaktovik hunters caught less than 10 percent of their total caribou at the mouth of the Canning River (Galginaitis, 2014b). For the regulatory year 1982-83 when caribou were not as available in other areas, Kaktovik hunters took 37 percent of their caribou harvest from the Canning River delta (Pedersen and Coffing, 1984; Coffing and Pedersen, 1985; Pedersen, 1990b). Thus, while the coastal areas west of Camden Bay may not be used as often as some other areas for caribou hunting, the ADF&G continues to map the Canning River delta as part of Kaktovik's intensive caribou use area (Galginaitis, 2014b). The Canning River delta area is important for hunting

when areas closer to Kaktovik are unproductive; it is approximately 40 miles east of the Proposed Action Area.

For hunters living in Utqiagvik, coastal caribou hunting has occurred as far east as Prudhoe Bay and as far west as Icy Cape on the Chukchi Sea coast (SRB&A, 2010). Caribou are commonly harvested year-round by Utqiagvik hunters. Caribou hunting occurs along the coast, along local rivers, and/or overland as far as the Inaru River. Peak hunting for caribou is July through September and occurs by boat along the coast and inland along various rivers. In the winter, caribou are taken as needed, using snowmachines. Utqiagvik hunters are least likely to take caribou in April and May (SRB&A, 2010).

Fish

Fishing is a major component of the annual subsistence rounds of Nuiqsut, Kaktovik, and Utqiagvik. Carothers et al. (2013) documented that the primary motivations for subsistence fishing on the North Slope reflect the core Iñupiaq values of food gathering, sharing, and connection to the land. The primary species of importance for these communities include Arctic cisco (qaaktaq), Arctic char (iqalukpik), and broad whitefish (aanaakliq) (SRB&A, 2010).

Pink and chum salmon have been documented in subsistence fisheries in the central North Slope region, and local harvest of salmon species has begun to increase within the last 10 to 20 years for Nuiqsut and Utqiagvik (Brewster et al., 2008; Carothers, Cotton, and Moerlein, 2013; Woods and Carothers, 2011). Salmon comprise a very minor portion of the subsistence fishery for Nuiqsut (Woods and Carothers, 2011). Residents of Kaktovik do not harvest salmon as a regular part of their seasonal round (Fuller and George, 1997; Pedersen, 1990a), but they have caught some on occasion in nets during July and August (Jacobson and Wentworth, 1982) and using rod and reel near the airport (Woods and Carothers, 2011). Salmon are a minor subsistence resource in the region compared to whitefishes and Arctic char, and thus subsistence salmon fishing is not analyzed in Chapter 4.

Arctic cisco are important to the culture of Iñupiat people living on the North Slope, and the subsistence Arctic cisco fishery on the Colville River delta provides a major source of food for residents of Nuiqsut (ABR et al., 2007; Fuller and George, 1997; SRB&A, 2010). Each spring a large number of Arctic cisco leave the Mackenzie River and travel to the central Beaufort Sea where they feed in summer in nearshore waters; a substantial number of these fish overwinter in the Colville River for approximately seven years, feeding in the sea near shore each summer before returning to the Mackenzie River to spawn when mature (ABR et al., 2007; SRB&A, 2010).

Nuiqsut is uniquely located for harvesting Arctic cisco as the Colville River plays an important role in the lifecycle of the fish. Nuiqsut residents primarily go fishing for Arctic cisco September through December, using snowmachines and nets (SRB&A, 2010). Fishing occurs in the Colville River delta, including Nigliq, Kupigrak, and Elaktaveach channels and the easternmost channels of the delta. Residents of Nuiqsut fish at their camps and near the community depending on time of season and their family situation. Subsistence catches of Arctic cisco in the Colville River vary yearly from an estimated low of 3,935 fishes in 2001 to a high of 46,944 fishes in 1993 (ABR et al., 2007). In 1992, researchers estimated that 45,402 Arctic cisco were harvested from the Colville River (Fuller and George, 1997).

Subsistence fishing for Arctic char is a common activity for residents of Nuiqsut, but these fish contribute less to the total subsistence harvest than Arctic cisco and broad whitefish (SRB&A, 2010). Using boats, nets, and rod and reel, residents of Nuiqsut primarily go fishing for Arctic char in August and September; some char are harvested in the peripheral months of May, June, July, October, and November (SRB&A, 2010). Subsistence fishers from Nuiqsut harvest Arctic char at several locations north of the village on Nigliq Channel and south of town along the Colville River to Sentinel Hill and at the mouth of the Chandler River.

Broad whitefish are an important resource that contributes highly to Nuiqsut's annual subsistence harvests (SRB&A, 2010). Residents most often go for broad whitefish before freeze up, using boats and nets and while fishing for other species; summer harvests of broad whitefish are used to make dried fish used during long winters as food and for sharing. Those who catch large amounts of broad whitefish are given status in the community because people prefer to eat and give away broad whitefish during the spring whaling festival and for Thanksgiving and Christmas (Carothers, Cotton, and Moerlein, 2013). Nuiqsut residents reported accessing broad whitefish areas between May and November; the peak season for broad whitefish occurs June through August with July being the most popular month (SRB&A, 2010). Nuiqsut residents fish for broad whitefish in the Colville River between its mouth and Sentinel Hill; they use Fish Creek, Itkillik River, Chipp River, and some area lakes for harvesting broad whitefish. Residents reported setting nets in the Nigliq Channel south of the community and in the easternmost channel of the Colville River delta. Subsistence fishers have noticed some broad whitefish from the Colville River and Nigliq Channel near Nuiqsut have patchy fungal-like lesions on the exterior surface; the lesions are caused by a common water mold (*Saprolegnia*) which is not exotic to the NSB and surrounding area (ADF&G, 2013).

The main fish harvested by Kaktovik residents for subsistence purposes include Arctic char, Arctic cisco, broad whitefish, and grayling (Jacobson and Wentworth, 1982; Pedersen, 1990a; SRB&A, 2010). Fishing by residents of Kaktovik has occurred as far west as the Sagavanirkok River and as far east as the Mackenzie River delta and in various inland rivers and lakes in between (Galginaitis, 2014b; SRB&A, 2010). Kaktovik residents harvest fish year-round with nets and rod and reel in coastal areas and around Barter Island, Arey Island, and Bernard Spit. Kaktovik fishers go for Arctic cisco July through August, Arctic char in all months but mainly July through August, broad whitefish July through August (Jacobson and Wentworth, 1982; SRB&A, 2010).

Kaktovik residents often harvest Arctic char and Arctic cisco in the same places, but Arctic cisco fishing is primarily limited to coastal areas, while Arctic char can be harvested both inland in rivers and in coastal areas (SRB&A, 2010). Arctic char is the most extensively used fish species for Kaktovik (Jacobson and Wentworth, 1982). Arctic char are the first to appear in nets after the ice goes out in early July. Kaktovik residents reported going for Arctic char along the coast between Mikkelsen Bay to the west and Shingle Point in Canada to the east, and inland in the Sagavanirktok, Canning, Hulahula, Kongakut, Mackenzie, and Big Fish rivers (SRB&A, 2010). Fishing for broad whitefish is less common than fishing for Arctic char and cisco for residents of Kaktovik. They primarily fish for broad whitefish along the coast or in the mouths of rivers between Mikkelsen Bay and Shingle Point and inland at Lake Schrader. Grayling has been reported to be a major subsistence resource for Kaktovik caught in many of the area's rivers and river deltas (Jacobson and Wentworth, 1982; Pedersen, 1990a).

Arctic cisco and char are important resources in the community of Utqiagvik. Harvest of Arctic cisco is limited to certain locations in the Utqiagvik area, and these fish occur in limited supply (SRB&A, 2010). Some residents travel to the Nuiqsut area to harvest them, or they receive these fish from family living in Nuiqsut. Near Utqiagvik, residents primarily harvest Arctic cisco in Kuyanak Bay, and some are harvested incidentally by nets in Elson Lagoon and toward the mouth of the Inaru, Meade, and Chipp rivers. Utqiagvik residents harvest Arctic cisco inland near the Usuktuk River and Teshekpuk Lake. Arctic ciscoes are best harvested right after freeze-up; harvests occur in all months except January and April with the greatest harvest effort in July through November (SRB&A, 2010). Arctic char are harvested near Point Barrow in Elson Lagoon and at various locations on the Inaru, Mead, and Chipp rivers of Dease Inlet. Arctic char have been harvested by Utqiagvik residents near Peard Bay and the Kugrua River. Most harvest occurs in July and August by boat, using nets or rod and reel. Some Arctic char are taken as early as May and as late as December.

Utqiagvik residents commonly harvest broad whitefish, which provides a substantial amount of their annual harvests in comparison to other fish (SRB&A, 2010). These fish are harvested as far east as

the Colville River and as far west as Peard Bay. Utqiagvik fishers most commonly reported harvesting broad whitefish on the Chipp, Inaru, Meade, Alsktak, and Miguakiak rivers and near Pittalukruak Lake (SRB&A, 2010). Some harvest locations were reported closer to Point Barrow such as Elson Lagoon, Lake Tusikvoak, and Lake Sungovoak and south of town at Walakpa and Peard bays on the Chukchi Sea. Most Utqiagvik fishers go for broad whitefish July through October. Unlike Arctic cisco, broad whitefish are best harvested right before freeze-up (SRB&A, 2010). Some broad whitefish are taken as early as May and as late as December. Boats and snowmachines are used most often to access harvest areas for broad whitefish. Broad white fish are a preferred food of whaling crews because eating them with seal oil helps keep hunters warm; broad whitefish are a favorite food and considered prestigious to be served and shared at spring whaling festivals (Brewster et al., 2008; Carothers, Cotton, and Moerlein, 2013; SRB&A, 2010).

Migratory Waterfowl

Geese are an important food resource on the North Slope because these provide fresh meat after a long winter and goose soup is a favorite of hungry whaling crews. Most Nuiqsut residents use waterfowl for subsistence purposes, and the primary species hunted are white-fronted geese (niqliq), Canada geese (israqutilik), and snow geese (kaṇuq) (Fuller and George, 1997; SRB&A, 2010). Fuller and George (1997) also reported harvest of brants (niqliṅṅaq) by Nuiqsut hunters. Using snowmachines, residents of Nuiqsut harvest geese April through June with most harvests occurring in May. Nuiqsut hunters go for geese in coastal areas just west of the mouth of the Colville River, including its tributaries and parts of the delta (SRB&A, 2010). Fish and Judy creeks are visited by geese hunters from Nuiqsut. Geese hunters prefer to stay close to town if the birds are nearby. The core goose hunting areas for Nuiqsut are located on Fish Creek, along the Colville River at various places south of town, and north of the community along Nigliq Channel.

Nuiqsut residents hunt for king eiders (qiṅalik) and common eiders (amauligruaq) (Fuller and George, 1997; SRB&A, 2010). They tend to combine eider hunting with hunting seals offshore north of the Colville River delta (SRB&A, 2010). For Nuiqsut, eider season starts in May and ends in September with most effort occurring in June and July. Nuiqsut residents reported hunting eider ducks in the Beaufort Sea between Atigaru Point and the mouth of the Kuparak River and farther east in an area overlapping Nuiqsut's bowhead whaling territory north and east of Cross Island (SRB&A, 2010). Other popular hunting areas for eider ducks include Fish Creek, near Ocean Point in the Colville River, and along the Colville River delta. Residents reported travelling offshore over 30 miles when hunting eiders in the ocean; the core eider hunting area for Nuiqsut is a smaller area up to ten miles offshore of the Colville River delta and east to Thetis Island (SRB&A, 2010).

Kaktovik residents hunt geese and eiders (Fuller and George, 1997; SRB&A, 2010). The four goose species hunted by Kaktovik residents include brants, white-fronted geese, Canada geese, and snow geese. Kaktovik residents hunt geese close to shore and along inland rivers during the months of April through October with most effort in May, June, and September (SRB&A, 2010). They reported hunting for geese as far west as Prudhoe Bay and as far east as the Mackenzie River delta. The smaller core hunting area for geese is located between Collinson Point to the west and Pokok Lagoon to the east and inland along the Hulahula, Okpilak, and Jago rivers and across from Barter Island.

In Kaktovik, eider duck hunting is less common than goose hunting and often occurs as the opportunity presents itself when hunting for other resources (SRB&A, 2010). Residents of Kaktovik hunt both king and common eiders usually in the same area and at the same time as goose hunting is occurring (SRB&A, 2010). Residents of Kaktovik reported hunting eiders along the coast as far west as the Sagavanirktok River and as far east as the Mackenzie River delta and inland along the Okpilak and Jago rivers (SRB&A, 2010). The areas nearest the Proposed Action Area where Kaktovik residents have recently reported hunting for migratory waterfowl are in Camden Bay, and their

reported use there is infrequent and usually occurs in combination with other subsistence activities (Galginaitis, 2014b).

SRB&A (2010) reported that Utqiagvik residents travel inland to camps and cabins after the spring bowhead whaling season with members of family and whaling crews to hunt for geese. Those who do not participate in whaling go to camp earlier. Geese hunted by most Utqiagvik residents include white fronted geese, Canada geese, brants, and snow geese. Geese, usually in the form of goose soup, are customarily shared by whaling crews at the Nalukataq festival. Most geese are taken in May and June. Utqiagvik residents reported hunting geese as far east as Teshekpuk Lake, past Wainwright to the south, and substantial distances offshore north and west of Point Barrow (SRB&A, 2010). Snowmachines are the primary means of transportation used for hunting geese.

Residents of Utqiagvik generally hunt for both king and common eiders with the highest harvest effort in May and August (SRB&A, 2010). This subsistence activity can be combined with bowhead whale hunting. Utqiagvik residents took more eiders than geese in the 1992 season (Fuller and George, 1997). Eider hunting occurs offshore north of Point Barrow at a location called Pigniq and in the Chukchi Sea near Peard Bay to the Tapkaluk Islands, near Wainwright, and on the Inaru and Meade rivers (SRB&A, 2010). Utqiagvik residents primarily use snowmachines and boats while hunting for eider ducks.

3.3.4. Community Health

3.3.4.1. Overview

Health is a state of complete physical, mental, and social well-being and not merely the absence of disease or infirmity (Habitat Health Impact Consulting, 2015; WHO, 1986). Community health is a collaborative enterprise that uses science from the public health field, applied strategies based on evidence, and other approaches from multiple disciplines and sectors of society (Goodman, Bunnell, and Posner, 2014; NRC, 2011). A recurring theme in contemporary definitions and assessments of community health is the essentialness of community engagement, collaboration, and partnerships (Andreen, Gove, and Contributors, 2014; Bhatia and Wernham, 2008; IPIECA, 2007; McAninch, 2012; HHIC, 2015). The primary objective of undertaking community health projects and assessments is to engage and work with stakeholders, partners, and communities in ways that are culturally appropriate, to optimize health and quality of life of all persons who live, work, and/or otherwise participate in potentially affected communities (Goodman, Bunnell, and Posner, 2014; NRC, 2011).

Community health is holistic and consists of multiple and interrelated determinants (Curtis, Kvernmo, and Bjerregaard, 2005; HHIC, 2014; Loring and Gerlach, 2009). For example, community health can be determined by where people live; the condition of their surroundings; their genetics; their diet and nutrition; their food security; their incomes and education levels; access to healthcare; their relationships with friends, family, and the larger community; and the integrity of their cultures and cultural identities (Bouchard-Bastien, Gagné, and Brisson, 2014; Curtis, Kvernmo, and Bjerregaard, 2005; Loring and Gerlach, 2009; McAninch, 2012; HHIC, 2015). These social and environmental conditions contribute to medical health outcomes in people, including diseases, illnesses, states of mental health, and accidental injuries or other traumas such as suicides (Appendix D; HHIC, 2015).

3.3.4.2. Community Health under the NEPA

The NRC (2011, p. 204) and the North Slope Borough (2015, p. 17) provided guidance to governmental agencies and the private sector for analyzing health effects under the NEPA. BOEM has summarized the guidance in this subsection.

To determine the level of potential health effects, agencies should consider:

- Scoping comments submitted on community health
- Levels of controversy surrounding perceived or documented health concerns
- Presence of other factors known to substantially affect community health (e.g., poor indoor and outdoor air quality)

There are some known effects of resource development that may adversely affect community health (NRC, 2011), including:

- Emissions of hazardous substances
- Changes in community demographics
- Involuntary displacement of residents or businesses
- Changes in industrial practices, employment, government revenues, or land-use patterns
- Reduced access to natural resources
- Changes in local food resources

In describing the community health environment, BOEM focuses on issues that are relevant to the community health concerns identified through scoping and collaboration with partners and stakeholders (NRC, 2011).

During public scoping for the Draft Liberty EIS, BOEM heard examples of community health concerns related to the Proposed Action and oil and gas projects in general, including:

- Effects of a large oil spill on biological resources, human health, and cultural well-being of communities that depend on subsistence resources, especially migratory marine mammals and ocean fishes
- Concern over food security, food purity, environmental contaminants, and related community health outcomes
- Social and environmental justice impacts in the community of Nuiqsut related to nearby industrial developments
- Concern that conditions related to encroaching industrial developments pose unreasonable risks to community health; for example, cumulative effects of air pollution from gas well flares, small fuel/oil spills, and industrial accidents may result in contamination of wildlife and other food and water resources and health risks to people such as increased respiratory problems (Ahtuanguaruak, 2015; SRB&A, 2009).

3.3.4.3. Community Health Determinants and Outcomes

Subsistence Foods, Food Security, and Nutrition

In the NSB, traditional subsistence foods anchor cultural identity and nutritional health, and security of all food resources is a key issue of public concern in Alaska (McAninch, 2012) that has been linked to resource development (HHIC, 2014, p. 25). Traditional foods are foods that originate in the populations' habitat such as seal, whale, caribou, birds, and fish, whereas foods found in the community store, for example, are imported (Vaktskjold et al, 2009). BOEM heard concerns over food security during scoping for the Draft EIS and provides a brief description of food security because it is related to subsistence harvest, diet, nutrition, and community health outcomes in the NSB (Loring and Gerlach, 2009).

Food security includes physical and economic access to sufficient, nutritious, and healthy foods (i.e., traditional and/or imported foods) to meet dietary needs and food preferences for an active and healthy life (Power, 2007). People who are food insecure report they cannot afford enough food, and they commonly skip meals or eat less than they need (HHIC, 2014). Food security means that the

food is safe, nutritionally adequate, culturally appropriate, and obtained in a way that upholds basic human dignity (FAO, 2006).

Iñupiat living in northern Alaska understand food security in a holistic manner. The Inuit Circumpolar Council-Alaska (ICCA) has developed and published a conceptual model of food security characterized by environmental health (ICCA, 2015). For the North Slope Iñupiat, environmental health and food security are achieved through the presence and strength of six factors (i.e., pillars of food security), including health and wellness, availability, accessibility, stability, Inuit culture, and decision making power and management. Three tools support the stability of the six factors: sources of knowledge, policy, and co-management (ICCA, 2015). The model is presented in the circular image of a traditional drum bound together by the spirit of all—Cilliam Cua, Eslam Yuga, Iñua, and Ellam Yua. The drum is held up by food sovereignty, which is a requirement to have food security (ICCA, 2015).

Food security depends on availability of sufficient quantities of food on a consistent basis; having sufficient resources or income to obtain appropriate foods for a nutritious diet; and appropriate uses of foods based on knowledge of basic nutrition and health (FAO, 2006). There are other factors that may substantially affect food security, including poverty and unemployment; educational attainment; changes in food sharing networks; vulnerability to global climate change; thawing of permafrost in which foods are stored; access to subsistence hunting lands; loss of traditional knowledge; and readily available imported foods (ANTHC, 2014; Bersamin et al., 2007; Power, 2007). Food security is not an individual or community health-related behavior; it is a social, political, and economic phenomenon (McAninch, 2012).

Residents of the NSB derive substantial health benefits from harvesting and eating traditional foods (McAninch, 2012; Smith et al., 2009). Many local traditional foods provide inexpensive and readily available nutrients, essential oils, antioxidants, calories, and protein; other benefits to health from traditional foods include protection from diabetes, improved maternal nutrition, and neonatal and infant brain development (Egeland, Feyk, and Middaugh, 1998; McAninch, 2012). Researchers have documented that traditional foods contribute more protein, monounsaturated fat, polyunsaturated fat, healthy fatty acids, vitamin B12, and iron than imported store-bought foods (Ballew et al., 2006; Bersamin et al., 2007). Seal oil and salmon were shown to be the main sources of omega-3 fatty acids for all individuals eating traditional foods; 69 percent of traditional food energy intake was from marine sources such as seal oil and fish (Bersamin et al., 2007). According to McAninch (2012), analyses of bowhead whale tissues used as subsistence foods have been found to be rich in protein, healthy omega-3 fatty acids, and important elements such as iron; the skin of the bowhead whale has been found to contain substantial amounts of dietary fiber, which has been found to be low in other Alaskan subsistence diets (Ballew et al., 2006).

Due to increased modernization of the rural Arctic, communities have increasing access to imported, store-bought and processed foods that lack nutritional value, and some households may be shifting away from a traditional subsistence diet to ensure food security or for other social or economic reasons (Loring and Gerlach, 2009; McAninch, 2012; Vaktskjold et al., 2009). Promotion of healthy imported foods high in vitamin C, calcium, and fiber also is essential to improving the diets of Alaska Native peoples (Bersamin et al., 2007). Store-bought imported foods do represent a degree of food security for rural Alaskans, but it remains questionable if imported foods in the NSB are sufficient to support an acceptable level of overall community health and cultural wellbeing (Loring and Gerlach, 2009, p. 470).

Traditional foods provide numerous other benefits in addition to good nutrition (AMAP, 2009, p. 22), including:

- Sharing traditional foods plays a role in the maintenance of social norms and is an important element of social wellbeing and local culture (Appendix D).

- Given the high cost of living in most Arctic communities, traditional foods can save families money.
- There are important spiritual aspects associated with traditional food use.
- There are many physical health benefits associated with harvesting and processing traditional foods.
- Sharing of food and material wealth is a cultural value ensuring that families or individuals are provided for in times of need.

Environmental Contaminants in Traditional Foods

The procurement and consumption of traditional foods is important for maintaining cultural values, cultural identity, and social wellbeing (Chan et al., 2006; McAninch, 2012; Vaktskjold et al., 2009). In many Alaskan communities, traditional foods are an economic necessity. However, foods from mammals, birds, and fish have been documented as the main source of human exposure to environmental contaminants (Vaktskjold et al., 2009). Native leaders and their communities are seriously concerned about reports of environmental contaminants from long-range and/or local origin that affect the quality of the land, water, and food species (Kuhnlein, 1995, p. 766). Some rural Alaskans may be dissuaded from harvesting and eating traditional foods because of perceived or documented contamination and related risks to human health (Loring and Gerlach, 2009). However, processing and cooking methods significantly affect nutrient and contaminant concentrations in traditional foods; direct testing of actual food items is highly recommended to determine risks and benefits of traditional diets (Moses et al., 2009). Researchers studied the tissues of spotted seals and sheefish in the Northwest Arctic region of Alaska and concluded traditional foods provide essential nutrients with relatively low risk posed by intake of environmental contaminants (Moses et al., 2009).

Cultural Wellbeing

Cultural wellbeing in communities plays an important role in the overall health and stability of communities and larger sociocultural systems (Vaktskjold et al., 2009). Rapid social, cultural, economic, and environmental changes in Inuit communities can adversely affect community health through changes in living conditions and ways of life (Curtis, Kvernmo, and Bjerregaard, 2005, p. 449). Maintaining cultural values and a positive cultural identity has been linked to positive physical and mental health outcomes for both individuals and communities in rural Alaska (McAninch, 2012). Preservation of and respect for the Iñupiaq language, respect for elders, participation in subsistence activities, sharing, and family stability are cultural values that remain strong. Iñupiaq language is spoken in the communities of Nuiqsut, Kaktovik, and Utqiagvik, and use of this language can strengthen cultural identity and overall wellbeing for the Iñupiat people of the North Slope. Two-thirds of Iñupiat households have at least one member who speaks fluent Iñupiaq and two-thirds have at least one household member who reads Iñupiaq language (McAninch, 2012). Across the NSB, elders are identified as highly respected members of their communities (HHIC, 2014; McAninch, 2012).

Municipal Infrastructure

Law enforcement and other services such as water, solid waste disposal, emergency services, and heating are essential infrastructure for all NSB residents (HHIC, 2014). These services vary between communities of the North Slope. Reliable supplies of potable water are critical to having good community health. Most communities rely on a surface water source with a water treatment system, and all communities in this region use a combination of piped and trucked water. A majority of houses in most communities have municipal sewage facilities with 10 percent of homes in Nuiqsut using holding tanks to store water (HHIC, 2014). A substantial portion of residents rely on outhouses. In many rural Alaskan communities the cost of water is a health and economic issue that leads to rationing of household water consumption. There are currently new challenges with infrastructure in a

North Slope environment that is warming and undergoing rapid changes such as sinking homes, erosion municipal lands, damage to buried water lines, and failure of traditional underground ice cellars used to store wild foods (ANTHC, 2014). These changes and challenges are projected to continue and worsen during the 25-year life of the Proposed Action.

Community Health Care Services

Health care services in the communities of the NSB are comprised of health clinics staffed by health aides. The Samuel Simmonds Memorial Hospital was built in Utqiagvik in 2010. Resource development projects such as the Proposed Action have potential to increase demand on local health care services, due to in-migration of workers or by increasing exposure of local residents to communicable diseases (HHIC, 2014). Resource development projects may improve availability of health care services by providing funding through tax revenues. In 2013, the total number of patient visits to health clinics and the Samuel Simmonds Memorial Hospital was 81,468 visits for Utqiagvik, 7,862 for Nuiqsut, and 5,130 for Kaktovik (HHIC, 2014). Residents of the NSB have to travel or be transported to a hospital or other healthcare provider in Fairbanks, Anchorage, or Seattle if they need more extensive care than the local clinics or the hospital in Utqiagvik can provide.

Income

Median household income levels can be used as a determinant of community health. In Alaska, income data normally include wages, the Alaska Permanent Fund Dividend, corporation dividends, and public assistance. The oil and gas industry is a major economic driver in the NSB and jobs in this industry can affect income and health status of these communities in beneficial ways (HHIC, 2014; McDowell Group, 2012). See Sections 3.3.2, Economy and 3.3.5, Environmental Justice for additional background information on employment, income, and poverty levels in the NSB.

Climate Change and Community Health

Global climate change (Section 3.1.6) is affecting the lives of Alaska Native peoples living on the North Slope and other rural residents of Alaska (ANTHC, 2014; Loring and Gerlach, 2009), especially in the Arctic region. Entire food production systems in parts of the Arctic are vulnerable to global climate change to various degrees that are difficult to predict (Ericksen, 2008). It is difficult for rural residents to accommodate these unprecedented and unpredictable changes. During the 25-year life of the Proposed Action residents of the NSB will continue to experience challenges related to changes and effects of global climate change.

Dramatic changes in weather and environmental conditions make subsistence harvests of traditional foods generally more challenging than in the recent past or altogether impossible for some households; for example, changing sea and river ice conditions and altered wildlife migration patterns can limit access to important resources such as sea mammals caribou, and freshwater fish (Huntington et al., 2016; Loring and Gerlach, 2009, p. 469). While hunters have been able to adjust and adapt to some changes, continued environmental changes linked to global climate change may further challenge their ability to acquire wild foods in the future (Huntington et al., 2016).

Traditional adaptation and coping mechanisms employed by rural residents do not work as well as they did in the past due to the dramatic and unpredictable nature of change; contemporary management policies used by governmental agencies to manage fisheries and wildlife can exacerbate the situation because these often lack flexibility and are slow to change (Loring and Gerlach, 2009).

3.3.4.4. Community Health Status

Community health professionals use data on physical health of communities such as infant mortality, nutrition, leading causes of death, and disease rates to establish the baseline health status of a community (Appendix D). In conjunction with the 2010 NSB Census and the NSB Planning Department, the NSB Department of Health and Social Services recently conducted a baseline

community health analysis (McAninch, 2012). BOEM has summarized some findings of the baseline health analysis in this subsection to provide a broad view of community health status and current health conditions and outcomes.

A large majority of NSB residents either self-reported or were reported to have good general health status; infant mortality rates have declined since the late 1970s; cases of vaccine-preventable illnesses and infectious diarrheal illnesses have decreased since the 1980s; since 2003, cigarette smoking has decreased in Utqiagvik households; self-reported prenatal alcohol use has declined since the early 1990s; and Alaska Native peoples living in the NSB have one of the lowest rates of type II diabetes in Alaska and a substantially lower rate of type II diabetes than most Native Americans living in the lower 48 states (McAninch, 2012).

As reported by McAninch (2012), the five leading causes of death in the NSB have remained constant since the early 1990s with small changes in rank order over the years; the State of Alaska reported the same leading causes of death for 1999 through 2013 in the NSB (DHSS, 2015); these have included:

- Cancer
- Heart disease
- Chronic lower respiratory disease
- Unintentional injury/trauma from accidents
- Suicide

Accidents and suicides are the leading causes of premature deaths in the NSB (McAninch, 2012). However, the NSB has demonstrated some positive community health achievements in these areas. Despite persistently high rates of suicide in the region, adults' self-reported mental health in the NSB is among the best in Alaska, and deaths rates from unintentional injuries have declined since the late 1970s.

In the 2010 NSB Census, the leading self-reported chronic health problems among adults were arthritis and/or chronic pain; high blood pressure; high cholesterol; and chronic respiratory problems. The leading admitting diagnoses to Samuel Simmonds Memorial Hospital in Utqiagvik in 2008-2009 were pneumonia, chronic obstructive pulmonary disease, and congestive heart failure (McAninch, 2012).

McAninch (2012) reported several factors that most likely have a positive influence on community health in the NSB, including:

- Participation in the subsistence way of life, which includes harvesting (i.e., hunting, fishing, gathering); processing and sharing traditional foods; and consumption of traditional foods. Participation in subsistence activities is the foundation of community life in the NSB.
- Commitment of local leadership to supporting strong cultural values and subsistence practices in schools, homes, at work, and in communities through policies such as subsistence leave and community festivals and feasts, which contribute to mental and physical health
- Increase in overall education levels
- Substantial improvements in water and sanitation infrastructure
- Below-average unemployment and poverty rates and above-average median household income
- Availability of basic health care, social services, and medical insurance
- The NSB provides a means to a strong local voice and personal empowerment in decisions and legislation affecting communities; self-determination may benefit overall mental and physical health.

- A majority of youth are connected and engaged with their schools and communities, and many youths show promise as future community leaders.

McAninch (2012) also reported several factors that probably have a negative influence on community health in the NSB, including:

- Food insecurity; more than one in three household heads in the NSB reported difficulty in getting the food needed to eat healthy meals, and more than one in four Inupiat household heads reported that, at times during 2010, household members did not have enough to eat (McAninch, 2012, p. 6).
- Inadequate amounts of physical activity and high consumption of sugary drinks; associated with increasing rates of obesity
- Low levels of helmet and seatbelt use; only 18 percent of heads of household in the NSB reported wearing a helmet when riding snowmachines or four-wheelers.
- Rising school drop-out rates; despite overall gains in education levels over the last three decades, overall high school graduation rates in the NSB School District are below state and national averages for some villages. Educational attainment is positively associated with health outcomes throughout life.
- Difficulty in accessing health services; residents must often travel long distances at high expense, inconvenience, and risk to access necessary health services.
- Increasing rates of sexually-transmitted infections impact reproductive health
- High rates of smoking and alcohol abuse
- High child maltreatment rates and domestic and sexual violence
- Economic stresses such as high cost of living and dramatic fluctuations in poverty and unemployment rates over the past one to two decades

To follow-up the baseline health analysis report, the NSB held a number of health forums in communities. Residents who participated in the forums engaged one another in discussing three questions designed to capture their general perspectives on community health. The questions included: What does a healthy North Slope mean to you? What assets does the North Slope have that encourages it to be a healthy community? What do you think are the most important health issues facing North Slope residents? After each group's discussions, common themes were highlighted in summary reports for each community.

Nuiqsut residents' discussions focused on the importance of eating healthy foods and having access to healthy foods, both subsistence and store-bought foods such as fresh affordable produce; the benefits of community gatherings, working together, and unity such as whaling festivals and holiday feasts; the importance of community organizations and programs such as churches and emergency response departments; the need to address social problems such as substance abuse, smoking, and suicide; and specific health concerns such as prevalence of cancers, respiratory health, mental illnesses, air pollution, and residential and industrial pollution (NSB, 2013a).

Discussions in the Kaktovik forum were similar to those in Nuiqsut and included the importance of healthy activities and physical fitness; eating healthy subsistence and store-bought foods; resolving social problems; and specific health concerns such as respiratory illnesses (NSB, 2013b).

Discussions in the Utqiagvik forum focused on the importance of better communication and collaboration among individuals, organizations, and communities; the importance that faith and spirituality have in becoming a healthy person, a belief that churches are a health asset to North Slope communities; the need to resolve social problems, including domestic violence and sexual assault; the health benefits of cultural identity, preservation of cultural values and the Iñupiaq language, and

learning from elders; education programs and providing more opportunities for youth in communities; and food security, healthy foods, eating less processed-foods from the grocery store, and continuation of a subsistence way of life (NSB, 2013c).

The results of the community health forums corroborate many of the findings of the baseline community health analysis reported by McAninch (2012). The main themes that emerged from these forums closely reflect three dimensions of sociocultural systems, including social organization, cultural values, and formal and informal institutions. This demonstrates the holistic nature of community health and its inseparableness from a subsistence way of life and an intact and functional sociocultural system in the NSB (Curtis, Kvernmo, and Bjerregaard, 2005; Loring and Gerlach, 2009).

3.3.4.5. Community Health and Subsistence

The 2010 NSB Census showed that participation in subsistence activities is high for North Slope households across all age groups (McAninch, 2012; HHIC, 2014). In the NSB, this is particularly the case for hunting land and sea mammals; fishing; and processing, sharing, and cooking wild foods. Fifty five percent of male heads of Iñupiaq households hunted sea mammals, and 70 percent of male household heads participated in subsistence fishing; for female heads of households, 49 percent participated in subsistence fishing, and 82 percent shared, cooked, and processed wild foods (McAninch, 2012).

Participation in traditional subsistence activities provides nutritious foods, physical activity, and social interactions across generations and is a vital part of maintaining cultural integrity and individual and community health in rural Alaska (McAninch, 2012, p. 90; Smith et al., 2009). Availability of and access to traditional foods and other local subsistence resources are critical determinants of physical and social health and cultural well-being for Nuiqsut, Kaktovik, and Utqiagvik.

3.3.5. Environmental Justice

3.3.5.1. Overview

Bass (1998) defined environmental justice (EJ) as the fair and socially equitable treatment and meaningful involvement of all people regardless of race, color, national origin, or income with respect to the development, implementation, and enforcement of environmental laws. Fair treatment means that low-income and minority groups should not shoulder a disproportionate share of the potentially negative environmental effects of government actions. EJ analyses should examine the equity of potential impacts across segments of the human population living in the affected environment (CGG, 2006). The purpose of doing an EJ analysis is to determine whether a Proposed Action would impact low-income and minority populations to a greater extent than it would impact the general population of an area or community (Bass, 1998; ICPG, 2003).

On February 11, 1994, the President of the United States outlined a policy on EJ in Executive Order (EO) 12898 entitled Federal Actions to Address Environmental Justice in Minority Populations and Low-Income Populations (59 *FR* 7629, February 16, 1994). The President wrote an accompanying Presidential memorandum to the heads of all Federal departments and agencies to underscore provisions of existing laws that help ensure all communities and persons across the United States live in a safe and healthful environment (Clinton, 1994). The intent of EO 12898 is to promote fair treatment of people of all races and income levels, so no person or group of people bears a disproportionate share of negative effects from government programs.

EO 12898 is especially pertinent to Federal actions that propose to develop natural resources, and for which environmental assessments (EA) or environmental impact statements (EIS) are required under the National Environmental Policy Act (NEPA) (USDOJ, 1995, 2016).

3.3.5.2. Environmental Justice under the NEPA

Assessment of EJ is a highly focused type of social impact assessment often conducted within the NEPA process (Bass, 1998; CEQ, 1997; EPA, 1998; Ross, 1994; USDOJ, 1995). EO 12898 and the Presidential memorandum require each Federal agency to consider EJ issues when undertaking Federal actions and implementing programs and policies having potential to cause social impacts. Social impacts are consequences of private or public actions or programs that result in substantial changes in people's ways of life, cultures, communities, economies, political systems, environments, health and wellbeing, personal and property rights, and/or aspirations for the future (CGG, 2006).

In the context of the NEPA process, each Federal agency has been directed to:

- Achieve EJ as part of its mission by identifying and addressing disproportionately high and adverse human health, economic, social, or environmental effects of its actions on minority and low-income populations in the United States (59 *FR* 7629, February 16, 1994)
- Evaluate in an EA/FONSI or EIS/Record of Decision (ROD) whether a Proposed Action or action would have disproportionately high and adverse effects on these populations (CEQ, 1997; Clinton, 1994)
- Provide early, meaningful, and effective opportunities for communities to identify alternatives, potential adverse effects, and mitigation measures while improving public access to meetings, documents, and notices used in the NEPA process; this may require agencies to use adaptive, innovative, and audience-appropriate approaches to overcome language, cultural, and economic barriers to effective participation in the decision-making process (CEQ, 1997; Clinton, 1994; EPA, 1998; 59 *FR* 7629, February 16, 1994)
- Develop mitigation measures in consultation with affected communities and groups for inclusion in NEPA decision documents and provide ongoing participation and coordination as mitigation measures are implemented (CEQ, 1997; EPA, 1998; GSA, 2000)
- Identify differential patterns of consumption of natural resources among these populations (i.e., differential rates of subsistence among minority populations, low-income populations, or tribes as compared to the general population) (CEQ, 1997; 59 *FR* 7629, February 16, 1994)

3.3.5.3. Description of Minority and Low-Income Populations

The Iñupiat people of the NSB are a recognized minority (CEQ, 1997) and the predominant year-round residents of the NSB (Hunsinger and Sandberg, 2013). The USCB (2014) defined minority to be individual(s) who are members of population groups of American Indian or Alaska Native; Asian or Pacific Islander (or Native Hawaiian); or Black (or African American), not of Hispanic (or Latino) origin. These population groupings are reported each decade during the U.S. Census. Low-income populations are defined as groups of people living below the poverty level as reported in the American Community Survey.

The CEQ (1997) identifies groups as minority or low income populations when either:

- The minority or low-income population of the affected area exceeds 50%.
- The minority or low-income population percentage in the affected area is meaningfully greater than the minority population percentage in the general population (e.g., Alaska).

Table 3.3.5-1. Ethnic Composition of Potentially Affected Communities¹

Community	Caucasian ³	Alaska Native and American Indian ⁴	Asian ⁴	Hispanic or Latino ⁵	African American ⁴	Native Hawaiian and other Pacific Islander ⁴	Some other Group ⁴	Minority ⁶
Utqiagvik	16.9	68.6	10.9	3.1	2.0	3.4	1.1	83.8
Kaktovik	10.0	90.0	0	0	0	0	0	90.0
Nuiqsut	10.0	89.6	0	0	0.7	0	0	90.0

Community	Caucasian ³	Alaska Native and American Indian ⁴	Asian ⁴	Hispanic or Latino ⁵	African American ⁴	Native Hawaiian and other Pacific Islander ⁴	Some other Group ⁴	Minority ⁶
Deadhorse-Prudhoe Bay	85.2	8.6	2.2	4.0	2.3	0.4	1.7	16.6
North Slope Borough	33.4	58.5	5.5	2.6	1.8	1.6	0.9	67.4
State of Alaska	66.7	19.5	7.1	5.5	4.7	1.6	2.1	35.4

Notes: ¹ Compared to the North Slope Borough and Alaska, 2010 (Hilcorp, 2015; USCB, 2013).

² Percent of population based on population size for each area, not adjusted for differential population sizes.

³ Alone

⁴ Alone or in combination with one or more other groups

⁵ Of any group

⁶ Minority = Total - (Caucasian alone + some other group alone + two or more groups + Caucasian and some other group) + (Hispanic or Latino, Caucasian alone + Hispanic or Latino + some other group alone).

Sources: Hilcorp, 2015; USCB, 2013

Table 3.3.5-2. Poverty Rates for Potentially Affected Communities.¹

Area	Percent of Residents Living below Poverty Line	Percent Margin of Error (+/-)
Utqiagvik	12.3	5.2
Kaktovik	14.8	13.3
Nuiqsut	3.0	3.4
Deadhorse-Prudhoe Bay ²	3.5	7.7
North Slope Borough	10.2	2.5
State of Alaska	10.1	0.3

Notes: ¹ Rates are compared to the North Slope Borough and Alaska, 2010 through 2014.

² Figures for Deadhorse-Prudhoe Bay area are from the 2007-2011 five-year U.S. Census estimates as reported in Hilcorp (2015).

Source: American Community Survey, Five-Year Estimates (USCB, 2014).

Utqiagvik, Kaktovik, and Nuiqsut qualify as minority or low-income populations, and therefore BOEM considers these to be EJ communities.

The NSB and three potentially affected communities both had aggregate minority populations larger than that for Alaska as a whole in 2010 (Table 3.3.5-1; Hilcorp, 2015). This was not the case for the Deadhorse-Prudhoe Bay area. Table 3.3.5-1 shows the minority compositions of Nuiqsut, Kaktovik, and Utqiagvik meet the 50 percent population threshold which classifies them as communities to be assessed in an EJ analysis on the basis of their proportional Alaska Native and total minority memberships (CEQ, 1997; Hilcorp, 2015; USCB, 2013). Utqiagvik and Kaktovik have a meaningfully higher estimated poverty rate than that of the NSB and State of Alaska, while Nuiqsut and the Deadhorse-Prudhoe Bay area have a lower estimated poverty rate than the NSB and Alaska (Table 3.3.5-2; USCB, 2014).

3.3.5.4. Environmental Justice and Scoping

Federal agencies are required to incorporate effective public participation and consultation in scoping for EJ analyses in the NEPA process (CEQ, 1997). Federal agencies that work with the public in rural Alaska are most effective when they improve cross-cultural communication methods and ensure full and meaningful participation by indigenous residents during scoping, including procedures to incorporate local and traditional knowledge in NEPA documents and other agency reports (Arctic Council, 2009; Bartley, Brooks, and Boraas, 2014; Jacobs and Brooks, 2011).

In Alaska, BOEM routinely hosts public scoping meetings and tribal consultations to inform its EJ analyses as part of the NEPA process. BOEM considers issues and concerns voiced at these meetings

and consultations as it formulates issues, alternatives, and potential mitigation measures (USDOI, MMS, 2002:3; USDOI, BOEMRE, 2011a).

In early November 2015, BOEM hosted public scoping meetings in Fairbanks, Kaktovik, Nuiqsut, Utqiagvik, and Anchorage and participated in government-to-government consultations with tribal leaders in Kaktovik, tribal leaders in Nuiqsut, and tribal leaders of the Iñupiat Community of the Arctic Slope in Utqiagvik. BOEM has also received written comments from the Alaska Eskimo Whaling Commission and Kuukpik Corporation in Nuiqsut, among others. BOEM heard a number of specific concerns and recommendations related to EJ issues and subsistence resources and practices including:

- Increased offshore vessel transit and barge traffic and potential effects on bowhead whales and subsistence activities from related noise
- Observations of too many offshore seismic studies; concern over lack of data sharing
- Disruptions to migratory Arctic cisco, caribou, and bowhead whales
- Critical need for a buffer zone to be established around the Cross Island whaling area
- Lack of comprehensive scientific assessments of sensitive habitats such as Camden and Foggy Island bays and other areas important to subsistence hunters
- Deflection of subsistence resources further away from hunters due to noise associated with the Proposed Action
- Lack of clearly defined mitigation measures and monitoring strategies to protect bowhead whale migration and subsistence practices
- Concern over food security, food purity, environmental contaminants, and related human health problems
- Increased infighting over economic benefits of oil and gas development
- Inadequate revenue sharing; recommended more royalties come back to local communities
- Too few opportunities for local people to be employed in the oil and gas industry
- Emergency use of the gravel island by locals as a safe haven during storm events or search and rescue operations
- Lack of support of communities on the part of industry after decommission
- Strong insistence that HAK conflict avoidance agreements with whaling captains and other local entities
- Recommended use of subsistence advisors and communication centers throughout the life of the Proposed Action
- Recommended use of good neighbor policies and endowments for communities
- Cumulative impacts of oil and gas development and global climate change on local way of life
- Fears of large oil spills destroying Iñupiaq culture and the future of Iñupiat children

In scoping, BOEM also heard concerns and recommendations related to the public involvement process including:

- Inadequate sharing of results from environmental analyses and research
- Inadequate involvement of top decision makers from agencies and industry at public meetings
- Concern that local people cannot understand documents used in the public process
- Too little time to review documents preventing meaningful public comments; recommended an extension of the comment period

- Recommended that all public meeting transcripts be posted to BOEM’s public website
- Feelings that the process is being rushed
- Inadequate involvement of elders and other local leaders in the process; lack of traditional knowledge studies
- Strongly recommend formal consultation with Kuukpik Corporation in Nuiqsut

Finally, BOEM heard specific concerns and recommendations related to planned actions described in the development and production plan, including:

- Concern about the siting of the gravel island due to strong ocean currents and storms; recommended locating the gravel island closer to shore
- Concern that man-made islands cause shoals, currents, and silting that affects local transportation routes, animal behavior, and sea life
- Concern that processing on the island would cause constant noise and adversely affect wildlife and hunters; recommended that the processing plant be located onshore
- Concern that proposed undersea pipelines may fail due to ice movements and divert caribou movements when continued onshore
- Concern that the proposed gravel mine site would cause displacement of residents from their native allotment

3.3.5.5. Environmental Justice and Subsistence

There is an important nexus between a subsistence way of life and EJ communities. In the Alaska OCS Region, BOEM primarily focuses EJ analyses on Section 4-4 of EO 12898, entitled Subsistence Consumption of Fish and Wildlife (USDOI, BOEM, 2014). The EJ analysis in Chapter Four will address human populations with differential patterns of subsistence consumption of fish and wildlife (59 *FR* 7629, February 16, 1994, p.7631).

3.3.6. Archaeological Resources

3.3.6.1. Background

Archaeological Resources are defined as “any prehistoric or historic district, site, building, structure, or object [including shipwrecks]...Such term includes artifacts, records, and remains which are related to such a district, site, building, structure, or object” (National Historic Preservation Act, Sec. 301 (5) as amended, 16 USC 470w(5)). Archaeological resources are either historic or prehistoric and generally include properties that are 50 years old or older and are any of the following:

1. Associated with events that have made a significant contribution to the broad patterns of our history
2. Associated with the lives of persons significant in the past
3. Embody the distinctive characteristics of a type, period, or method of construction
4. Represent the work of a master
5. Possess high artistic values
6. Present a significant and distinguishable entity whose components may lack individual distinction
7. Have yielded, or may be likely to yield, information important in history

Archaeological resources are subject to National Historic Preservation Act (NHPA) review if they are historic properties, meaning those that are on, or eligible for placement on, the National Register of

Historic Places (NRHP). These resources may be found in the Proposed Action Area both offshore and onshore.

Underwater archaeology can be divided into two discrete types of sites:

- Vessel wrecks—both shipwrecks and airplane wrecks—and any remains associated with them
- Submerged landscapes and prehistoric sites

3.3.6.2. Liberty Project Archaeological Surveys

This area has been archaeologically surveyed and assessed during the past seventeen years because of industrial interest in the potential for extracting oil from the Liberty prospect.

Archaeological surveys have identified sites on land, although none would be directly affected by the project. There is also the potential for archaeological resources to be present offshore because the shallow waters that extend to the Shelf.

Marine Archaeological Surveys

Seismic surveys have been conducted and archaeological analyses has been performed of geotechnical and geological (G&G) coring performed to evaluate the proposed island location and pipeline route to shore (Rogers, 2014, 2015). The first marine archaeological survey was conducted of the Liberty proposed island site and pipeline right-of-way. This effort, documented in a report entitled “Liberty, Cultural Resource Assessment, Foggy Island Bay in Stefansson Sound, Alaska,” was conducted by W. Marmaduke and W.D. Watson, prepared by Watson Company, Inc. for British Petroleum Exploration Alaska (BPXA) in 1998.

The Watson report (1998:10-11) found that the seafloor in the project area has been subjected to surface disturbance from ice gouging and other processes. The report indicated that seismic reflectors could represent buried stream channels, the most prominent of which were interpreted as being Pleistocene in age. The report concluded that if any terrestrial archaeological sites were associated with this or any other extant paleo-landforms, they would be protected because they are deeply buried. Lessor paleo-channels and buried peat deposits would also be protected by a veneer of Holocene marine sediments (Watson and Marmaduke, 1998: 10-11, fig. 20, and Plates 3&4).

The agency Archaeological Working Group (AWG) noted that the area of Foggy Island Bay, shoreward of the position of the wintertime ice pressure-ridge, generally has the potential for archaeological resources. (Thurston et al., May 3, 2000 Memorandum “Review of the Archaeology Report for Liberty Production Island and Pipeline Route – Watson Company, 1999 for BPXA”). They also did not agree with purported dating organic peat, instead pointing out that no age dating had been performed of the peat or any of the sediments or paleo-landforms.

Moreover, the very presence of these paleo-landforms argued against destructive erosional processes caused by wave action, instead supporting the AWG’s theory that the intact paleo-landforms had been submerged by flooding or drowning without significant destructive wave action. Before the differing interpretations could even be addressed, BPXA stated that instead of constructing an artificial island and a pipeline to shore, they would directionally drill from shore.

In 2013, when BPXA determined it would not be possible to directionally drill the Liberty prospect, these archaeological questions and concerns were again raised; BPXA agreed that geological coring would be subjected to archaeological analysis.

G&G surveys were performed in the winters of 2013-15; one final coring was done during the open water season of 2015. Two alternate pipeline routes were analyzed as was the proposed LDPI. Additionally, three-dimensional seismic work in association with side-scan sonar and a magnetometer was analyzed for archaeological remains. No archaeological or shipwreck remains on the seabed were

identified, and no potential archaeological remains in the sub-seabed were identified, including buried landforms that might represent archaeological sites.

Based on these surveys, HAK geologists mapped subseabed paleochannels that may be associated with remnant geomorphological features capable of containing archaeological material (Figure 3.3.6-1):

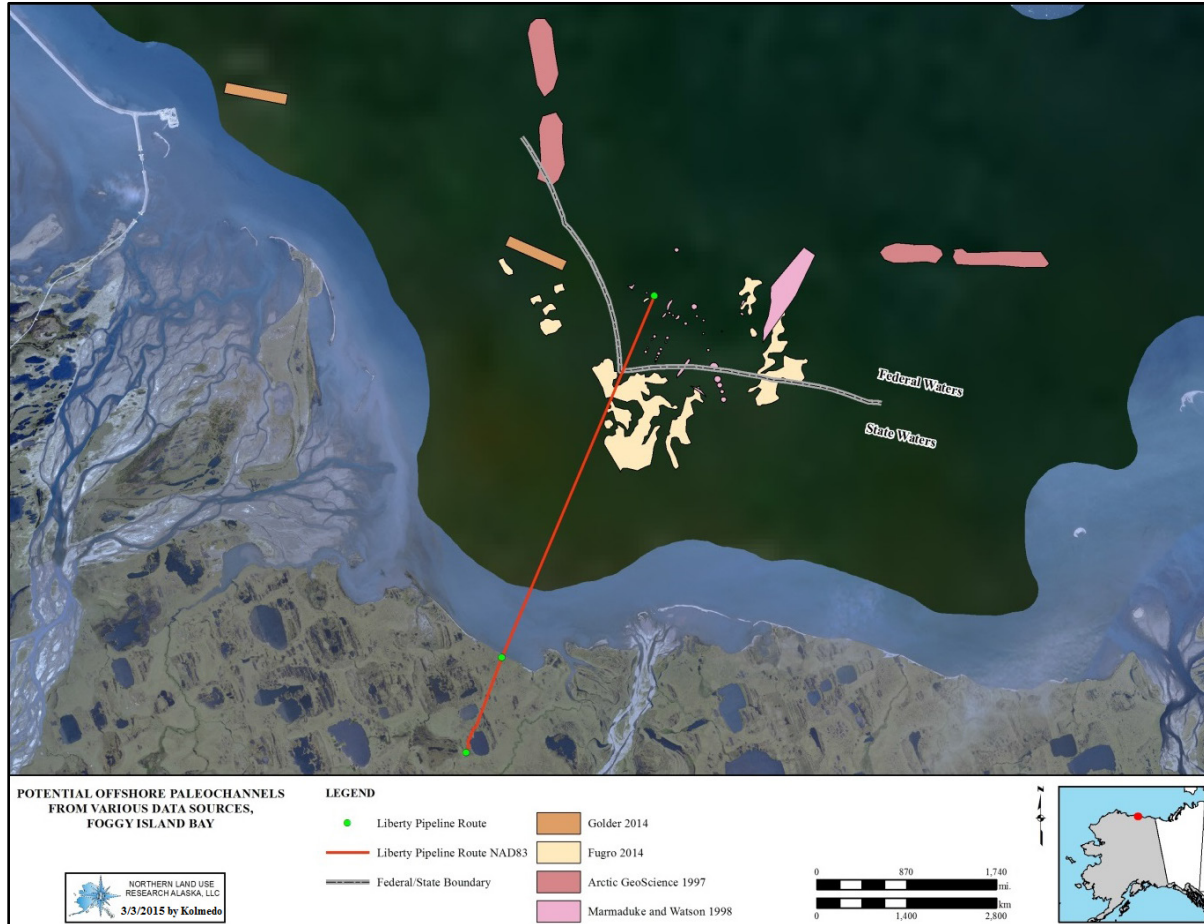

Figure 3.3.6-1. Potential Offshore Paleochannels.

Historic Resources

One whaling ship, the Reindeer, lost in 1894, presumably off Reindeer Island (subsequently named after the vessel), though the precise site of the shipwreck is unknown. The location has been given as Cross Island, “Midway Island” (Reindeer and Argo islands), or “Return reef” (the Return Islands west of Gwydyr Bay). If the shipwreck occurred in the vicinity of Reindeer Island, it would be about 14 miles northwest of the project area.

Reindeer Island has migrated more than 1,000 ft. to the south and west since the 1955 aerial photographs were taken, and no part of the island documented in 1955 exists today; hence no archaeological sites can be present on the island (Reanier, 2008). Thus, it is unlikely that the proposed project would affect shipwrecks (<http://www.boem.gov/Alaska-Coast-Shipwrecks/>; Reanier, 2008).

Terrestrial Archaeological Surveys

Several terrestrial archaeological surveys have been conducted in the vicinity of the Liberty project since the mid-1970’s (Campbell, 1974; Higgs, 2013; Lobdell, 1980, 1987, 1998a, 1998b; Reanier, 2004, 2008, 2014; Rogers, 2013). Four of these reports were specifically linked to the current Liberty

DPP (Higgs, 2013; Reanier, 2008 and 2014; Rogers, 2013). Sites on land identified through previous archaeological surveys were relocated. The current proposed gravel mine site has been intensively archaeologically surveyed and no new archaeological sites, either on or offshore, have been identified. The Proposed Action would avoid all documented terrestrial archaeological sites.

This page intentionally left blank

Environmental Consequences

This page intentionally left blank

Table of Contents

Chapter 4. Environmental Consequences.....	4-1
4.1. Introduction and Background for Analysis.....	4-1
4.1.1. Accidental Oil Spills, Exercises and Drills, and Gas Release Estimation	4-1
4.1.2. Impacts Scale.....	4-8
4.2. Physical Environment.....	4-9
4.2.1. Oil and Gas Geology/Petroleum Engineering.....	4-9
4.2.2. Water Quality.....	4-13
4.2.3. Air Quality.....	4-31
4.2.4. Climate Change.....	4-49
4.3. Biological Environment.....	4-52
4.3.1. Lower Trophics.....	4-52
4.3.2. Fish.....	4-64
4.3.3. Birds.....	4-75
4.3.4. Marine Mammals.....	4-104
4.3.5. Terrestrial Mammals.....	4-199
4.3.6. Vegetation, Wetlands, and Substrate.....	4-223
4.4. Sociocultural Systems.....	4-231
4.4.1. Sociocultural Systems.....	4-231
4.4.2. Economy.....	4-240
4.4.3. Subsistence Activities and Harvest Patterns.....	4-250
4.4.4. Community Health.....	4-284
4.4.5. ``Environmental Justice.....	4-294
4.4.6. Archaeological Resources.....	4-297
4.5. Very Large Oil Spill Scenario.....	4-303
4.5.1. Background.....	4-303
4.5.2. OCS Well Control Incidents.....	4-303
4.5.3. Hypothetical VLOS Scenario.....	4-304
4.5.4. Fate and Behavior of an Oil Spill.....	4-308
4.5.5. Hypothetical VLOS Conditional Probabilities and Trajectory Modeling.....	4-311
4.5.6. Gas Release.....	4-312
4.6. Recovery and Cleanup.....	4-312
4.6.1. Scenario Phases and Impact Producing Factors.....	4-314
4.6.2. Opportunities for Prevention, Intervention, and Response.....	4-316
4.7. Effects of a Very Large Oil Spill (VLOS).....	4-319
4.7.1. Effects of a VLOS on Water Quality.....	4-319
4.7.2. Effects of a VLOS on Air Quality.....	4-325
4.7.3. Effects of a VLOS on Lower Trophic Level Organisms.....	4-329
4.7.4. Effects of a VLOS on Fish.....	4-334
4.7.5. Effects of a VLOS on Birds.....	4-340
4.7.6. Effects of a VLOS on Marine Mammals.....	4-348
4.7.7. Effects of a VLOS on Terrestrial Mammals.....	4-390
4.7.8. Effects of a VLOS on Vegetation and Wetlands.....	4-395
4.7.9. Effects of a VLOS on Sociocultural Systems.....	4-402
4.8. Unavoidable Adverse Effects.....	4-414

4.9. Relationship between Local Short-Term Uses and Maintenance and Enhancement of Long-Term Productivity	4-415
4.10. Irreversible and Irrecoverable Commitment of Resources	4-415

List of Figures

Figure 4.2.2-1. XSS Concentrations and Affected Boulder Patch Areas-LDPI Winter Construction.	4-18
Figure 4.2.2-2. XSS Concentrations and Affected Boulder Patch Areas During Spring Moat Dragline Operations at the LDPI.	4-19
Figure 4.2.2-3. XSS Concentrations and Affected Boulder Patch Areas During Winter Pipeline Trench Excavation, Westerly Current	4-20
Figure 4.2.2-4. XSS Concentrations and Affected Boulder Patch Areas during Winter Pipeline Trench Backfill, Westerly Current	4-21
Figure 4.2.2-5. Affected Boulder Patch by 1 mg/L XSS from Backfill Mound Degradation	4-22
Figure 4.2.2-6. Affected Boulder Patch by 5 mg/L from Backfill Mound Degradation.....	4-22
Figure 4.2.2-7. Affected Boulder Patch by 10 mg/L XSS from Backfill Mound Degradation ...	4-23
Figure 4.2.2-8. Affected Boulder Patch by 15 mg/L XSS from Backfill Mound Degradation ...	4-23
Figure 4.2.2-9. Affected Boulder Patch by 20 mg/L XSS from Backfill Mound Degradation ...	4-24
Figure 4.2.3-1. Proposed Action Modeled Receptors	4-35
Figure 4.2.3-2. Proposed Action NAAQS Comparison.....	4-37
Figure 4.2.3-3. Proposed Action Class II MAI Comparison.....	4-38
Figure 4.2.3-4. Alternative 3A NAAQS Comparison.....	4-42
Figure 4.2.3-5. Alternative 3B Class II MAI Comparison.....	4-43
Figure 4.2.3-6. Alternative 3B NAAQS Comparison.....	4-44
Figure 4.2.3-7. Alternative 3B Class II MAI Comparison.....	4-45
Figure 4.2.3-8. Alternative 4A NAAQS Comparison.....	4-46
Figure 4.2.3-9. Alternative 4B Class II Comparison.	4-47
Figure 4.2.3-10. Alternative 4B NAAQS Comparison.....	4-48
Figure 4.2.3-11. Alternative 4B Class II MAI Comparison.....	4-48
Figure 4.3.4-1. Frequency Bands and Source Levels for Common Arctic Offshore Activities.	4-105
Figure 4.3.4-2. Comparing Marine Mammal Hearing to Proposed Action Noises	4-105
Figure 4.3.4-3. Generalized Underwater Audiograms of Marine Mammals	4-108
Figure 4.3.4-4. NMFS Level A and B Harassment Thresholds and Modeled Threshold Shifts.	4-109
Figure 4.3.4-5. Relationship between geohazard survey noises, ringed and spotted seal and Pacific walrus audiogram and injury and behavioral disturbance thresholds	4-112
Figure 4.3.4-6. Relationship between geohazard survey noise, beluga audiograms, modeled mysticete audiogram and the NMFS injury and behavioral disturbance thresholds.....	4-113
Figure 4.3.4-7. Geohazard Survey Noise and the Interim Behavioral Threshold (Level B Harassment) for Marine Mammals.	4-114
Figure 4.3.4-8. Vessel, Snow Mobile, Hovercraft, Helicopter , and Drilling Noises vs. ringed, spotted seal, and Pacific walrus audiograms, and NMFS Noise Injury (Level A Harassment)Thresholds	4-120

Figure 4.3.4-9.	Helicopter, Drilling, Hovercraft, Snow Machine, and Vessel Noises vs. Beluga Whale Audiograms and NMFS Injury Thresholds from noise (Level A Harassment)	4-121
Figure 4.3.4-10.	Comparing vessel, helicopter, hovercraft, snow machine, and drilling noises to the NMFS interim behavioral thresholds (Level B Harassment).....	4-122
Figure 4.3.4-11.	Ice road and LDPI Construction Noise and Pinniped Audiograms, Audiograms compared to the sounds emitted by proposed construction equipment on ice road and proposed LDPI construction	4-126
Figure 4.3.4-12.	Ice road and LDPI Construction Noise and Beluga Whale Audiograms.....	4-127
Figure 4.3.4-13.	Ice road and LDPI Construction Noise Behavioral Response Thresholds (Level B Harassment) for impulse and continuous noise	4-128
Figure 4.3.4-14.	Beaufort Sea Polar Bear Habitat by Season.....	4-189
Figure 4.3.4-15.	Chukchi and Bering Sea Polar Bear Habitat by Season	4-192
Figure 4.3.6-1.	Wetlands Affected and Alternative Mine Sites (AES, 2016).	4-229
Figure 4.4.6-1.	Proposed DPP Significant Archaeological Surveys.	4-300
Figure 4.5.4-1.	Oil Spill Weathering Processes and Behavior in an Arctic Open Water Environment.....	4-309
Figure 4.5.4-2.	Oil Spill Weathering Processes and Behavior in an Ice-present Arctic Environment.....	4-310
Figure 4.7.8-1.	Land segments (LS) and onshore/inland vegetative communities potentially impacted by a VLOS.....	4-401

List of Tables

Table 4.1.1-1.	Small Spill Assumptions.....	4-2
Table 4.1.1-2.	Total and Annual Potential Small Oil Spills in barrels (bbl) throughout Program.....	4-2
Table 4.1.1-3.	Large Spill Assumptions.....	4-3
Table 4.1.1-4.	Resources Described in BOEM’S Oil-Spill Risk Analysis.	4-4
Table 4.2.4-1.	Potential Annual Greenhouse Gas Emissions of Liberty DPP (tons of CO _{2e}).....	4-50
Table 4.2.4-2.	Lifecycle GHG Emissions.*	4-51
Table 4.3.1-1.	Sediment Plume Acreage Estimate ¹	4-52
Table 4.3.1-2.	Chance by days of a Large Spill on Liberty LDPI or Pipeline Contacting a Given ERA*.....	4-60
Table 4.3.2-1.	Chance of a Large Spill on Liberty LDPI or Pipeline Contacting a Given ERA or LS.....	4-71
Table 4.3.3-1.	Summary of Impacts to Birds by Impact Producing Factor.	4-75
Table 4.3.3-2.	Bird Resource Areas with Highest Percent Chances of Contact by a Large Oil Spill ¹	4-97
Table 4.3.4-1.	Marine Mammal Boxcar Frequency Range.....	4-106
Table 4.3.4-2.	Non-Impulsive Noise Thresholds and Criteria for Beaufort Sea Marine Mammals.....	4-106
Table 4.3.4-3.	Impulse Noise Criteria and Thresholds for Marine Mammals.	4-107
Table 4.3.4-4.	NOAA Fisheries Current In-Water Acoustic Thresholds.....	4-108

Table 4.3.4-5.	Distance from Development Noise to 120 dB.....	4-110
Table 4.3.4-6.	Extent of noise above interim behavioral thresholds for transportation activities.....	4-117
Table 4.3.4-7.	Northstar Project Ice road and Island Construction Heavy Equipment Noise. . .	4-126
Table 4.3.4-8.	Theoretical distances from impact pipe-driving and pile driving at the Proposed LDPI to onset of Permanent Threshold Shifts among marine mammal.	4-129
Table 4.3.4-9.	Summer Conditional Probabilities of Large Spill Contacting a Whale ERA.....	4-152
Table 4.3.4-10.	Alternatives 2-5 Gravel Mine Location and Impacts to Whales Compared to the Proposed Action.....	4-156
Table 4.3.4-11.	Alternatives 2-5 Gravel Mine Location and Impacts to Pacific Walrus Compared to the Proposed Action.....	4-162
Table 4.3.4-12.	Summer Conditional Probabilities of a Large Spill Contacting a Polar Bear ERA or GLS.	4-187
Table 4.3.4-13.	Winter Conditional Probabilities of a Large Spill Contacting a Polar Bear ERA or GLS.	4-187
Table 4.3.4-14.	Polar Bear Habitat ¹ Grid Cells and Chance of Contact during Summer.	4-189
Table 4.3.4-15.	Polar Bear Habitat ¹ Grid Cells and Chance of Contact during Fall.	4-190
Table 4.3.4-16.	Polar Bear Habitat ¹ Grid Cells and Chance of Contact during Winter.	4-190
Table 4.3.4-17.	Polar Bear Habitat ¹ Grid Cells and Chance of Contact during Spring.....	4-191
Table 4.3.4-18.	USFWS Polar Bear Spring Habitat ¹ Grid Cells and Chance of Oil Contact. (537 Cells).	4-192
Table 4.3.4-19.	USFWS Polar Bear Winter Habitat ¹ Grid Cells and Chance of Oil Contact.	4-192
Table 4.3.4-20.	Alternatives 2-5 Gravel Mine Location and Impacts to Polar Bears Compared to The Proposed Action.	4-199
Table 4.3.5-1.	Northstar Project Heavy Equipment Noise.....	4-201
Table 4.3.5-2.	Conditional Probabilities of a Large LDPI or Pipeline Spill Contacting a Given ERA.	4-210
Table 4.3.5-3.	Conditional Probabilities of a Large LDPI or Pipeline Spill Contacting a Muskox ERA.....	4-214
Table 4.3.5-4.	Conditional Probabilities of a Large Spill Contacting a Grizzly Bear Habitat or ERA.	4-218
Table 4.3.5-5.	Chance of a Large Spill on LDPI or Pipeline Contacting an Arctic Fox Habitat or ERA.....	4-222
Table 4.3.6-1.	Summary of Proposed Impacted Areas under USACE Jurisdiction.	4-224
Table 4.3.6-2.	Comparison of Wetlands and <i>Arctophila fulva</i> within the Gravel Mine Site Alternatives.....	4-230
Table 4.4.1-1.	Summary of Impacts to Subsistence Practices for Nuiqsut, Kaktovik, and Utqiagvik.	4-232
Table 4.4.2-1.	Annual Average Employment (Number of Jobs) ¹ by Project Phase.	4-242
Table 4.4.2-2.	Peak/Maximum Employment by Community and Project Phase.	4-243
Table 4.4.2-3.	Annual Average Employment Labor Income by Community and Project Phase ¹	4-243

Table 4.4.2-4.	Peak/Maximum Employment Labor Income by Community and Project Phase ¹	4-243
Table 4.4.2-5.	Federal, SOA, and NSB Revenues (Millions of 2015\$) ¹	4-244
Table 4.4.2-6.	Social Cost of Carbon (in billions of dollars) at Various Discount Rates.	4-247
Table 4.4.2-7.	Summary of Effects by Economic Measure.	4-248
Table 4.4.3-1.	Primary Subsistence Hunting and Fishing Activities for Nuiqsut, Kaktovik, and Utqiagvik.....	4-252
Table 4.4.3-2.	Proposed Action Temporal and Spatial Overlap with Primary Subsistence Activities.	4-252
Table 4.7.1-1.	Spill sizes by Type for Trajectory Analysis.....	4-324
Table 4.7.4-1.	Journal Literature on the Effects of the <i>Deepwater Horizon</i> Oil Spill on Fish.	4-334
Table 4.7.5-1.	Conditional Probabilities for Bird ERA Contact 90 Days ¹ after VLOS.	4-347
Table 4.7.6-1.	Summer Contact Probabilities for Marine Mammal ERAs.	4-370
Table 4.7.6-2.	Winter Contact Probabilities for Marine Mammal ERAs.....	4-370
Table 4.7.6-3.	Annual Contact Probabilities for Marine Mammal ERAs.	4-371
Table 4.7.6-4.	Seasonal Contact Probabilities for Marine Mammal LSs.....	4-371
Table 4.7.6-5.	Contact Probabilities for Marine Mammal GLSs.	4-371
Table 4.7.6-6.	Bowhead Whales–Summer, Winter, and Annual Fraction of VLOS.	4-373
Table 4.7.7-1.	Summer Conditional Probabilities for Terrestrial Mammal GLSs.	4-394
Table 4.7.7-2.	Winter Conditional Probabilities for Terrestrial Mammal GLSs.....	4-394
Table 4.7.7-3.	Annual Conditional Probabilities for Terrestrial Mammal GLSs.....	4-394
Table 4.7.8-1.	Summer or Winter Fraction of a Large Oil Spill Contacting Land Segments with Sheltered Vegetated Low Banks, Salt/Brackish Water Marshes, or Inundated Low-Lying Tundra.	4-398
Table 4.7.8-2.	Fraction of a VLOS Contacting Vegetative Wetlands.*.....	4-400
Table 4.7.9-1.	Effects of a VLOS on Economic Measures.	4-405
Table 4.7.9-2.	Conditional Probabilities for Subsistence Use Areas 90 Days after VLOS.	4-411

This page intentionally left blank

CHAPTER 4. ENVIRONMENTAL CONSEQUENCES

4.1. Introduction and Background for Analysis

This chapter presents analyses of potential environmental, social, cultural, and economic impacts resulting from the oil and gas development, production, and decommissioning activities described in the 2015 Hilcorp Development Plan (referred to as “the Proposed Action,”) and each alternative considered by BOEM. Technical information cited from the Proposed Action refers to the 2015 Liberty DPP (Hilcorp, 2015). Information cited from Hilcorp’s Environmental Impact Assessment is cited as the 2015 Liberty EIA (Hilcorp, 2015, Appendix A).

In this chapter, BOEM considers:

- The activities which comprise the Development and Production Plan
- The levels of effect used to measure impacts
- Mitigation measures to avoid and minimize impacts to resources

4.1.1. Accidental Oil Spills, Exercises and Drills, and Gas Release Estimation

This section summarizes technical information from the 2015 Liberty DPP (Hilcorp, 2015) and Appendix A of this Draft EIS (Hereafter “Appendix A”) to create a set of assumptions for purposes of environmental effects analysis of the Proposed Action. Appendix A provides background information from which these assumptions are derived.

Accidental oil spills have a varying potential to occur. Accidental oil spills or gas releases may potentially affect resources during all phases of the Proposed Action, depending on the spill type, source, and size (volume). The assumptions in this section were developed using technical information and historic data (Appendix A), modeling results, statistical analysis, professional judgment, and 2015 Liberty DPP-specific information. The analyses are based on a set of assumptions about the number, volume, and types of spills or releases estimated to occur during the different phases.

Small Oil Spills (<1,000 bbl)

Small spills, although accidental, occur during oil and gas activities with generally routine frequency and are considered likely to occur from development, production or decommissioning activities associated with the Proposed Action. The majority of small spills would be contained on the proposed LDPI or landfast ice (during winter). Small refined spills that reach the open water would be contained by booms or absorbent pads; these would also evaporate and disperse within hours to a few days. A 3 bbl refined oil spill during summer evaporates and disperses within 24 hours and a 200 bbl refined oil spill during summer evaporates and disperses within 3 days. The subsections below estimate the number and size of small spills that could occur during various phases of the Proposed Action.

Summary of Assumptions about Small Spills

BOEM bases the analysis of effects from small oil spills for the Proposed Action on the assumptions in Table 4.1.1-1 (below). BOEM assumes about 70 small spills—most of which would be less than 10 bbls—would occur over the course of the 25 1/2-years of development (development begins ~2 years before production), production (~ 22 year duration), and decommissioning (~18 month duration). These estimated small spills are totaled and rounded to the nearest whole number. Details are further discussed below and in Appendix A.

Table 4.1.1-1. Small Spill Assumptions.

Variable	Assumption for Purposes of Analysis
Assumed number of Spills	70 total – Rounded to the nearest whole number and inclusive of spills in which the spill volumes are greater than 1 bbl and less than 1000 bbl. A subset of small spills less than or equal to 1 bbl can also occur.
Activities	Small refined oil spills occur during development, production, and decommissioning activities. Small crude oil spills occur during development and production activities.
Timing	Small refined and crude oil spills during development and production could occur any time of the year.
Spill Sizes	Development, production, and decommissioning: most spills would be 2-3 bbl. 58 spills would be >1 bbl and ≤10 bbl 11 spills would be >10 bbl and ≤200 bbl 1 spill would be >200 bbl and <1000 bbl
Medium Potentially Affected	<ul style="list-style-type: none"> • Air • proposed LDPI and if not contained then the water or ice • Open water • Broken ice • On top of or under solid ice • Shoreline • Tundra or snow • Ice road • Freshwater systems
Weathering	A 3 bbl refined oil spill during summer evaporates and disperses within 24 hours. A 200 bbl refined oil spill during summer evaporates and disperses within 3 days. (Appendix A, Tables A.1-6 and A.1-7)

Sources: Robertson et al., 2013; BOEM, 2016

Development, Production, and Decommissioning

About 70 small crude and refined spills could occur during the life of the project. Small crude oil spills would not occur before drilling operations begin. Small refined oil spills may occur during development, production, and decommissioning. The estimated total and annual number and volume of small refined oil spills is displayed in Table 4.1.1-2. The majority of small spills are likely to occur during the ~22-year production period, which is an average of about 3 spills per year.

Table 4.1.1-2. Total and Annual Potential Small Oil Spills in barrels (bbl) throughout Program.

Estimated Total Spills	Estimated Total Volume	Average Annual Spills	Average Annual Volume
0–70	0–196 bbl	0–3	0–9 bbl

Note: Table represents the estimated number and volume of small crude or refined oil spills by total and annual average during development, production, and decommissioning.

Large Oil Spill (≥1,000 bbl)

A large spill is a statistically unlikely event. Based on the Oil-Spill Risk Analysis (OSRA) data summarized in Appendix A, there is a 99.33% chance of no large spills occurring and a 0.67% chance of one or more large spills occurring over the life of the Proposed Action. The statistical distribution of large spills shows that it is much more likely that no large spills occur than that one or more occur over the life of the Proposed Action. However, because large spills are an important concern, and no one can foresee the future, BOEM assumes a large spill could occur during the Proposed Action and conducts a large oil spill analysis for the development and production activities. This “what if” or conservative analysis addresses any potential serious environmental harm and informs the decision maker of potential impacts should a large spill occur. Assuming one large spill occurs instead of zero allows BOEM to more fully estimate and describe potential environmental effects.

One large spill of crude or refined oil is assumed to occur during the development or the production phases. This assumption is based on considerable historical data that indicates large OCS spills ≥1,000 bbl may occur during the development and production phases (Anderson, Mayes, and Labelle, 2012). The mean number of large spills is calculated by multiplying the spill rate from Bercha (2016), by the estimated barrels produced (0.11779 Bbbl or 117.79 Million Barrels). By adding the mean number of large spills from the proposed LDPI and wells (~0.0043) and from pipelines (~0.0024), a mean total of 0.0067 large spills were calculated for the Proposed Action. Based on the mean spill

number, a Poisson distribution indicates there is a 99.33% chance that no large spill occurs over the development and production phases of the project, and a 0.67% (less than 1%) chance of one or more large spills occurring over the same period.

The assumptions BOEM uses to analyze the potential effects of a large crude or refined oil spill that could occur from development and production, are set forth in Table 4.1.1-3. The analysis of the potential effects from a large spill is contained in Section 4.1.2.2.

The spill sizes and types assumed in the analysis are based on median spill sizes for each type of spill in the historical record and on operator provided spill volume estimates. For further description of the methodology BOEM used to estimate spill volume and type, see Appendix A, Section A-1 Accidental Large Oil Spills.

Table 4.1.1-3. Large Spill Assumptions.

Variable	Assumption for Purposes of Analysis
Percent Chance of One or More Occurring	99.33% chance no large spills occurring; 0.67% chance of one or more large spills occurring
Number of Spills/Release	1 large spill occurring during development and production from either the proposed LDPI or offshore pipeline or onshore pipeline.
Timing	A large spill could occur any time of the year. A large crude oil spill could occur during the development (drilling) or production phases. A large diesel spill could occur from the proposed LDPI during development or production.
Sizes and Oil Type	Offshore Pipeline (5,000 bbl crude oil rupture or 1,700 bbl crude oil leak), Onshore Pipeline (2,500 bbl crude oil spill), or proposed LDPI (5,100 bbl crude oil or diesel spill)
Medium Potentially Affected	<ul style="list-style-type: none"> • Air • proposed LDPI and if not contained then water or ice • Open water • Broken ice • On top of or under solid ice • Shoreline • Tundra or snow
Weathering After 30 days	A 5,100 bbl diesel oil spill will evaporate and disperse much more rapidly than crude oil, generally within 1-30 days. After 30 days in open water or broken ice, BOEM assumes the following weathering for a 5,100 bbl crude oil spill: 16.5-17.2% evaporates, 3.3-56.1% disperses, and 26.7-80.2% remains (Appendix A, Tables A.1-2 and A.1-3).
Chance of Large Spill Contacting and Timing	Assuming a large spill occurs, the time to contact and chance of contact from a large oil spill are calculated from an oil-spill-trajectory model (Conditional Probability; Appendix A, Tables A.2-1 through A.2-11).
Chance of One or More Large Spills Occurring and Contacting	The overall chance of one or more large oil spills occurring and contacting is calculated from an Oil-spill Risk Analysis (OSRA) model (Combined Probability; Appendix A, Tables A.2-10 through A.2-11).
Spill Response	The OSRA does not account for response, cleanup, or containment and therefore may overestimate the chance of a large spill contacting environmental resource areas (ERAs), land segments (LS) or grouped land segments (GLS). Cleanup is analyzed separately as mitigation or disturbance.

A subset of large spills is the Very Large Oil Spill (VLOS) which is sometimes also called a Catastrophic Discharge Event. For the 2017-2022 Five-Year Program Final PEIS (USDOJ, BOEM, 2016), BOEM defined a reasonable range of potentially catastrophic OCS spill sizes by applying extreme value statistics to historical OCS spill data (Ji et al., 2014). Extreme value statistical methods and complimentary methods (Bercha Group, 2014) were used to quantify the potential frequency of different size spills (USDOJ, BOEM, 2016, Figure and Table 3.3-1). In combining the per well spill frequency with the number of wells, no very large spills are estimated to occur over the life of the development project.

With the exception of rare events, such as the 2010 *Deepwater Horizon* explosion, oil spill, and response (DWH event), the number of spills and the volume of oil entering the environment from accidental spills have been decreasing in recent decades, even as petroleum consumption has risen (USCG, 2011; USEIA, 2014). The DWH event is considered a low-probability, high-impact event and a spill of this volume is highly unlikely to occur during any activity phase, but if one did occur (as the DWH event), the impacts would be major. In Section 4.5, BOEM addresses the possibility of a

VLOS occurring and uses historic data to assess the likelihood of a VLOS occurring. In Section 4.7, BOEM analyzes the potential environmental effects of such an event.

4.1.1.1. Oil-Spill Risk Analysis (OSRA)

BOEM studies how and where large offshore spills move by using an oil-spill trajectory model with the capability of assessing the probability of oil-spill contact to resource areas, known as the Oil-Spill Risk Analysis (OSRA) model (Smith et al., 1982; Ji, Johnson, and Li, 2011). Potential impacts of a large oil spill are discussed for each resource presented in Chapter 4, where meaningful, resource-specific analyses of potential large spill impacts also consider the OSRA results. For conditional probabilities, BOEM estimates a spill occurs from the island or pipeline and estimates the chance of contact to a specific resource area within a given time. The transport of the spilled oil depends on the winds, ice, and ocean currents of the area. Combined probabilities are based on a) the chance of one or more large spills occurring, and b) the chance of one or more spills contacting a resource over the life of the project (conditional probabilities). Conditional probabilities are discussed within appropriate resource analysis sections listed in Table 4.1.1-4. Full discussion and the results are provided in Appendix A. Within the regional OSRA study area (shown in Appendix A, Map A-1), BOEM defines the following resource areas in Appendix A, Sections A 3.1.3 and A 3.1.4:

- **Environmental Resource Area (ERA).** Polygons representing spatial and temporal areas of social, economic, or biological resources or resource habitat areas
- **Land Segment (LS).** Coastline of Beaufort Sea and Chukchi Sea divided into 146 LSs
- **Grouped Land Segment (GLS).** Some LSs added together to form larger geographic or resource areas
- **Boundary Segment (BS).** 40 offshore boundary segments surround the study area

The presence of a particular environmental resource may be represented by one or all of these features (e.g., birds and ice seals are expressed using ERAs and GLSs), as summarized in Table 4.1.1-4.

Table 4.1.1-4. Resources Described in BOEM'S Oil-Spill Risk Analysis.

General Resource	Table (Appendix A)	ERA	LS	GLS	BS
Lower Trophic Level Organisms	Table A.1-11	X			
Fish	Table A.1-12	X	X	X	
Birds	Table A.1-13	X		X	
Marine Mammals (Whales)	Table A.1-14	X			X
Marine Mammals (Polar Bears and Walrus)	Table A.1-15	X	X	X	
Marine Mammals (Ice Seals)	Table A.1-16	X		X	
Terrestrial Mammals	Table A.1-17			X	
Subsistence Resources	Table A.1-18	X		X	

Sources: X's show that the resources are described in the OSRA.

4.1.1.2. Oil Spill Response and Exercise Requirements

The Oil Pollution Act of 1990 (OPA 90) established new oil spill preparedness requirements for both the Federal government and the facility plan holder operating in the offshore. For the Federal government, the provisions of OPA 90 required the development of a National Contingency Plan (NCP) which would provide for efficient, coordinated, and effective action to minimize damage to the environment in the event of a release. The NCP assigned specific duties and responsibilities to Federal departments and agencies in coordination with State of Alaska (SOA) and local agencies. Executive Order (EO) 12777 implemented the provisions of OPA 90 and made specific assignments regarding which Federal departments were responsible for specific portions of the Act.

Under the NCP the Federal government was charged with developing Area Contingency Plans for each designated geographic area of the country. The Area Contingency Plan (ACP) describes the area

covered along with areas of special economic or environmental importance that might be damaged by a discharge, describes in detail the responsibilities of a plan holder and of Federal, SOA, and local agencies in removing a discharge, provides a list of equipment, dispersants or other mitigating substances and devices and personnel available to a plan holder, compiles a list of local scientists, both inside and outside Federal government service with expertise in the environmental effects of spills, and describes how the plan is integrated into other ACPs and vessel, offshore facility, and onshore facility approved response plans.

The EO 12777 assigned to the Department of the Interior the responsibility for the following: establishment of procedures, methods, and equipment and other requirements for containing discharges of oil and hazardous substance from offshore facilities, including associated pipelines, other than deepwater ports; issuance of regulations requiring owners or operators of offshore facilities, including associated pipelines to prepare and submit response plans; the approval of means to ensure the availability of private personnel and equipment; the review and approval of such response plans; and the authorization of offshore facilities including associated pipelines, to operate without approved response plans. DOI in turn delegated these responsibilities to BSEE. BSEE promulgated regulations governing oil spill response requirements which are found in 30 CFR 254, Oil Spill Response Requirements for Facilities Located Seaward of the Coast Line.

Permittees operating offshore are required to comply with the applicable Federal oil spill response requirements for each activity site. These regulations implement the provisions of OPA 90 for offshore oil and gas operations which place the responsibility for preparing for and responding to a spill on the operator. Each operator is required to prepare an oil spill response plan (OSRP) for their facilities seaward of the coastline. In the OSRP the operator must include an emergency response action plan, a worst-case discharge (WCD) volume and response scenario, an inventory of response equipment sufficient to respond to the WCD scenario, contractual agreements with oil spill removal organizations (OSRO) who will provide response services, a dispersant-use plan, an in situ-burning plan, and a training and response drills plan. The OSRP must also be consistent with the requirements of the NCP and any applicable ACP for the area in which the facility is located. In the SOA the ACP is a combined Federal/SOA plan entitled the Unified Plan for Preparedness to Oil Discharges and Hazardous Substance Release (Unified Plan). The Unified Plan is further supplemented by ten Subarea Contingency Plans covering the SOA. For activities located on the North Slope, the OSRP must also be consistent with the North Slope Subarea Contingency Plan. Prior to the start of drilling operations, the operator must have a BSEE-approved OSRP.

In developing the WCD scenario, operators are required to conduct an appropriate trajectory analysis for the area where the facility would be located. This analysis must identify onshore and offshore areas that a discharge potentially could impact and further identify resources of special economic or environmental concern that may be present. The operator must describe what strategies would be used to protect these areas and the resources required. BSEE may require operators to demonstrate proposed spill response strategies before approval of an OSRP is granted. When determining equipment requirements for the WCD, the operator is required to derate the throughput capacity of skimmers to 20% of the listed capacity to compensate for environmental factors such as sea state, temperature, available daylight, and emulsification of the oil to ensure sufficient recovery capabilities. BSEE, through its approval action, also may require operators to stage spill response equipment near areas of concern to facilitate more rapid deployment to protect critical resources and limit exposure to the oil.

To ensure plan holder readiness, BSEE conducts routine inspections of the operator's facilities to ensure that the identified spill response resources are readily available and in the quantities and condition described in the OSRP. Inspections of response equipment owned by OSROs along with maintenance and inspection records also are conducted to verify response readiness. Reviews of

training records and spill drill reports are made to verify that response personnel have completed the mandatory training and that all parts of the OSRP have been exercised as required in the regulations.

BSEE also will conduct government initiated unannounced exercises (GIUE) to test the operator's ability to carry out the provisions of the OSRP. These exercises may take the form of tabletop exercises (TTX) and/or equipment deployments. Government initiated unannounced exercises are conducted in accordance with the National Preparedness Response Exercise Program (NPREP) Guidelines. These guidelines were developed in cooperation with USCG, EPA, PHMSA, and BSEE to allow regulatory agencies the opportunity to evaluate various aspects of a plan holder's preparedness, including their emergency procedures and their contracted OSROs' capabilities for proper and timely equipment deployment. For BSEE regulated offshore facilities, the number of GIUEs is determined by the Oil Spill Preparedness Division (OSPD) Chief. A facility will not participate in a BSEE initiated unannounced exercise more than once every 36 months, unless the results of previous exercises indicate that follow-up drills are warranted due to inadequate performance during a drill.

In preparing for a GIUE, be it a TTX or equipment deployment, BSEE will coordinate their activities with other Federal, SOA and local regulatory partners in an attempt to conduct a joint exercise to leverage scarce resources in order to more readily assess plan holder and OSRO capabilities within the local area. Based on the results of these drills, BSEE may require the operators to amend their OSRP to improve response operations.

A TTX GIUE would occur at the plan holder's incident command post and usually does not entail mobilization or deployment and operation of equipment. The TTX is aimed at testing the capabilities of the incident management team (IMT) to organize, support, and direct a response. These exercises generally last from two to eight hours depending on how quickly the IMT is able to complete BSEE's exercise objectives.

Equipment deployment GIUEs would occur either at the plan holder's OSRO or at their offshore facility if equipment is staged on-site. These exercises usually involve the deployment and operation of equipment from a single tactic cited in the OSRP but can involve multiple tactics. For open-water and broken ice conditions, a deployment will generally involve between one and three boats used to deploy and tow containment boom, deploy and operate a skimmer, and shuttle temporary storage devices to and from a lightering point. These exercises would normally be conducted in close proximity to the industrial area near West Dock or at the proposed LDPI so as to limit impacts on wildlife. The deployment GIUE would last approximately four to eight hours depending on the time to mobilize, deploy and operate the equipment.

In the largest potential deployment GIUE the plan holder could be expected to deploy upwards of 20 vessels ranging in size from an oil spill response vessel (OSRV) or oil spill response barge and tug (OSRB) up to 300' to multiple smaller vessels ranging in length from 55' to 12'. The vessels are either jet propelled, propeller driven, or air boats. These vessels would be used to tow containment boom, deploy skimmers and conduct skimming operations, shuttle on-water storage devices like mini-barges and towable bladders to and from shore, and deploy shoreline protection booming in shallow waters and along the shoreline.

The size and amount of containment boom would vary based on the tactic, skimming platform, and water depth. For an OSRV or OSRB, these vessels would be used in deeper coastal waters and open ocean, boom size can range from 30" up to 79" in width, and deployed and towed in lengths of up to 2,000'. For smaller workboats conducting skimming operations, boom ranging from 38" to 50" would most likely be employed in lengths up to 500'. In a large scale exercise it is expected up to 3 such vessels would conduct these operations at various locations around the exercise location. For nearshore and shoreline protection booming, shallow water and delta boom would be utilized. Most tactics call for lengths of up to 200' to be deployed and anchored in position either offshore or on the

shoreline. In a large scale drill it is anticipated up to two such tactic demonstrations would be required.

The skimmers deployed during the course of the exercises will be hydrophilic brush, and disk models. Because these skimmers are designed to recover oil with very little water uptake, only the disks or brushes would be rotated during operations and the pumps would not be employed other than in a brief burst to demonstrate they are operational. These skimmers are hydraulically driven.

BSEE may also require a plan holder to mobilize equipment used for non-mechanical response options such as in situ burning (ISB) and dispersant application operations. For ISB operations, an operator has the option of igniting a pool of collected oil using hand-held ignitors or a torch slung beneath a helicopter. BSEE may require the operator demonstrate their ability to mobilize and deploy the helicopter and helitorch and conduct simulated operations over a designated area offshore. A single sortie is expected to satisfy the operator's capability. In addition to the aircraft, up to two vessels operating as spotters would provide feedback to the pilot and burn operations supervisor.

It is highly unlikely that the operator would request or receive approval for dispersant use for operations in the Beaufort Sea given the shallow water depths in the area of operations. However if the operator establishes the capabilities to apply dispersants, BSEE could require the operator to demonstrate their ability to carry out a dispersant application. Dispersants may be applied via fixed wing aircraft, rotary wing aircraft with application equipment slung beneath, or by vessel.

Fixed wing application could be carried out using a large multi-engine cargo aircraft like a Hercules C-130 to small single-engine planes, such as a Cessna 188 AGWAGON. The application aircraft would make multiple passes at approximately 75 feet above the ocean surface to discharge their payload. The use of a spotter aircraft is also required to guide the dispersant aircraft over the designated area and to indicate when to begin and end dispersant application. Spotter aircraft would be single or multi-engine propeller planes, most likely a Cessna or Twin Otter. An on-water monitoring vessel would also be required to observe operations. BSEE may require the dispersant application aircraft to discharge fresh water to the ocean surface to demonstrate the operability of the application system. On-water application would only occur if required approvals from Federal and SOA authorities are received prior to the exercise.

Rotary-wing application of dispersants is another option. This involves a helicopter with a dispersant application system slung beneath the aircraft. A spotter aircraft is also required for application along with a monitoring vessel as described for fixed-wing aircraft application. The helicopter would make multiple passes over the target area to simulate dispersant application.

The other option for dispersant application is from a vessel-based system. Spray arms are affixed to the vessel and the vessel then transits through the oiled surface applying the dispersants. Vessels used for application can range from an OSRV/OSRB to smaller vessels depending on the operating environment. Spotter aircraft are required to guide and observe application along with a monitoring vessel.

During winter, the ocean surface freezes solid thereby necessitating the use of winter tactics to respond to a discharge to the environment. A GIUE conducted during solid ice conditions would involve land-based tactics adapted for the ice environment. Depending on the scenario, the operator may be required to mobilize response equipment such as a front-end loader, dump truck, vacuum truck, loader mounted ice trimmer, bobcats, snowmobiles, ATVs, and snow blowers to respond to a simulated blowout to solid ice.

For a simulated release from a pipeline, the operator would be required to deploy augers to bore through the ice to the water below, utilize a Rube Witch Trencher or chain saws to cut slots in the ice sheet to allow the oil to surface and pool, and then employ a skimmer such as a foxtail driven by a

gasoline powered generator. Multiple ATVs, bobcats, trucks and gasoline powered lighting systems would be required to support these response exercise operations.

If an oil spill occurs the operator is required to immediately implement their OSRP and notify the National Response Center of the spill, regardless of volume. If the suspected volume of the spill is 1 barrel or greater, the operator must orally notify the BSEE Regional Supervisor of Field Operations without delay. It is up to the operator to mobilize sufficient equipment and personnel to control, contain, and clean up the spill to the greatest extent possible. In the event that the spill volume is significant or there are critical resources at risk, a Unified Command (UC) may be stood up to direct cleanup operations. For incidents occurring on the North Slope, the UC would be composed of the Responsible Party (RP); the Federal On-Scene Coordinator (FOSC), who for offshore events is from the USCG; the State On Scene Coordinator (SOSC), who is a representative from the Alaska Department of Environmental Conservation, and the Local On-Scene Coordinator (LOSC), who is a representative from the North Slope Borough (NSB). This group works jointly to establish spill-response priorities and direct overall response activities. If the RP is unable to adequately carry out response activities, the FOSC has the option to assume command of the response to ensure appropriate response actions are taken.

Effectiveness of cleanup operations is highly dependent on volume, location, and time of year in Alaska. A small spill occurring during winter on solid ice and snow can be readily cleaned up using conventional land-based equipment such as shovels, snow blowers, and bulldozers, resulting in a near 100% recovery rate. Spills to open-water and broken-ice conditions result in lower recovery rates of 5-20% of the spilled oil. Removal of a spill on water requires the deployment of containment boom to corral and concentrate the oil into a recoverable thickness, skimmers to remove the oil from the water surface, temporary storage vessels to hold the recovered oil and water, and vessels to deploy the equipment and personnel. Recovery rates are lower on water because the oil can disperse rapidly throughout the area, and responders must first locate and contain the spill before it can be recovered.

Conclusion

Government initiated unannounced exercises (e.g., oil spill drills), are infrequent, of short duration, (<8 hours), and utilize existing equipment. GIUE's would not alter the impact conclusions for any of the resources analyzed in this DEIS.

4.1.2. Impacts Scale

4.1.2.1. Area of Effects

The area of effect varies by resource. For example, marine noise may carry outside of the Proposed Action Area (generally defined as a 10-mile radius around the proposed LDPI location) and can affect marine mammal behaviors outside of it, whereas birds, terrestrial mammals, and vegetation may be unaffected beyond a very short range. Therefore, each individual resource has a different area of effect for the impact producing factors.

4.1.2.2. Impacts Scale

The analyses in this chapter apply a scale to categorize the potential impacts to specific resources and evaluate the significance of those impacts. The scale takes into account the context and intensity of the impact based on four parameters: detectability, duration (i.e., short-term or long-lasting), spatial extent (i.e., localized or widespread), and magnitude (i.e., less than severe or severe, where the term "severe" refers to impacts with a clear, long lasting change in the resource's function in the ecosystem or cultural context).

Subject matter experts used the best available information and their professional judgment to determine where a particular effect falls in the continuum on a relative scale from "negligible" to

“major.” For biological resources, impacts were determined based on changes on the stock or population, rather than the individual level.

The impacts scale applied in this DEIS is as follows:

- **Negligible:** Little or no impact
- **Minor:** Impacts are short-term and/or localized, and less than severe
- **Moderate:** Impacts are long lasting and widespread, and less than severe
- **Major:** Impacts are severe

In applying this scale and the terms that describe impact categories (levels of effect), subject matter experts considered the unique attributes and context of the resource being evaluated. For example, in considering impacts to biological resources, attributes such as the distribution, life history, and susceptibility of individuals and populations to impacts were considered. Factors considered for subsistence activities include the fundamental importance of these activities to cultural, individual and community health, and well-being. Based on these unique characteristics, impacts to subsistence activities are considered severe, and thus, major, if they would disrupt subsistence activities, make subsistence resources unavailable or undesirable for use, or only available in greatly reduced numbers for a substantial portion of a subsistence season for any community.

4.2. Physical Environment

4.2.1. Oil and Gas Geology/Petroleum Engineering

The DPP describes Hilcorp’s reservoir model, depletion strategy, and predicted oil, water, and gas production rates. This section identifies and discusses impacts associated with the Proposed Action and Alternative Actions that affect the Liberty Field reservoir.

4.2.1.1. The Proposed Action

The Proposed Action’s impacts to the Liberty Field reservoir would occur due to the drilling of wells into the reservoir, producing fluids from the reservoir, and injecting gas and water into the reservoir.

The Proposed Action would optimize the production and economic recovery of hydrocarbons in the reservoir due to the implementation of the field development plan described in the Liberty DPP.

As wells are drilled and additional information about the Liberty Field reservoir, its structure, extent, rock and fluid properties and the actual well performance characteristics of injectors and producers is gathered, modifications to future well completion designs, placement, count, pressure maintenance, and other development plans would be made. This active reservoir management effort would optimize field performance and maximize the ultimate economic recovery of hydrocarbons and thus the resulting cumulative oil production at abandonment. Economic factors, including the price of oil, new technologies, operating costs, and operating conditions would also affect the production rates, ultimate recovery, and time of abandonment for the Liberty Field reservoir.

Reservoir Access

Wells drilled from the Liberty Drilling and Production Island (LDPI) surface wellhead locations into the Liberty Field reservoir would access and produce its fluids.

The development plan describes the drilling and completion of wells including the planned number of wells, the well type (disposal, producer, water or gas injector), the order in which these wells are drilled, the bottomhole locations, and the potential completion intervals for these wells.

From the proposed LDPI location, the Liberty Field reservoir would be accessed and produced through conventional slant wells with tangent angles that are less than 65 degrees from vertical. The

wells would be directionally drilled from the LDPI surface wellhead locations to reach the full extent of the reservoir with a departure of no more than 2.6 miles radius. This means that each well's bottomhole location in the Liberty Field reservoir would be no more than 2.6 miles in a horizontal direction away from that well's surface location.

Reservoir Depletion

BOEM's independent reservoir model and reservoir simulation studies using Hilcorp's development plan indicate that the Liberty Field reservoir would recover from 41% to 48% of the 180 million barrels of oil (MMBO) originally in place. These studies indicate a peak production rate of approximately 58,000 barrels of oil per day (BOPD) within the first two years of production with an estimated project life of 22 years.

4.2.1.2. Alternative 2 (No Action)

Under this Alternative, the Proposed Action would not be approved and the actions described in the Liberty DPP would not take place. No wells would be drilled to access the reservoir and no depletion of hydrocarbons in the reservoir would occur. There would be no impacts to the Liberty Field reservoir.

4.2.1.3. Alternative 3 (Alternate LDPI Locations)

Under this Alternative, the proposed LDPI would be relocated to one of two locations to reduce impacts to the Boulder Patch from sedimentation/ increased turbidity during pipeline trenching and proposed LDPI construction.

The proposed development plan is based on a depletion scheme of five producers and four water and/or gas injectors in the Liberty Field reservoir. Moving the location of the LDPI would alter both how these wells access the reservoir, when production begins, the rate of production, and the cumulative recovery of hydrocarbons from the Liberty Field reservoir.

Alternative 3A: Relocate LDPI Approximately One Mile to the East

Alternative 3A would relocate the Liberty Development and Production Island (LDPI) to a site approximately one mile to the east.

Reservoir Access

This alternative would decrease the total aggregate measured length for all of the production wells. The three planned producers targeting the southeast portion of the reservoir would have their total aggregate wellbore lengths shortened by an estimated ten thousand feet. The two production wells planned to target the northwest portion of the field would have wellbore paths lengthened an estimated one thousand and two thousand feet.

This alternative would decrease the total aggregate measured length for all of the injection wells. The first development well planned to be drilled, a gas injection well to intersect the reservoir at the crest of the structure to the northeast, would be lengthened by an estimated two thousand four hundred feet. The three remaining planned water injectors targeting the center of the reservoir would each be shorter by a total aggregate measured length of approximately four thousand three hundred feet.

This alternative would allow the Liberty Reservoir to be accessed and produced through conventional slant angle wells directionally drilled from the LDPI surface wellhead locations to reach the full extent of the reservoir with a departure of no more than 2.4 miles radius. This means that the bottom hole well location would be no more than 2.4 miles in a horizontal direction away from the well's surface location in order to fully penetrate and help drain the entire reservoir. The resulting well angles would allow for standard well drilling, completion, and servicing mechanisms.

Reservoir Depletion

The aggregate reduction in the wellbore path lengths for all injectors and producers combined would be approximately seven thousand two hundred feet (an estimated five percent of the Proposed Action's planned total wellbore length). As a result of decreased wellbore path lengths, less rock cuttings and excess drilling mud would be generated for disposal either by the grind and inject (G&I) facility or alternatively transported onshore for disposal. It should take less total time to drill these wells, depending on the timing and seasonal drilling windows. In addition, it is likely that earlier initial production of fluids from the reservoir and injection of water and gas into the reservoir would occur.

The shorter total aggregate measured length of the flow path for the producers would result in less overall pressure drop due to flowing friction up the production tubing. Less total reservoir energy would be required to overcome this flowing friction as reservoir fluids are produced.

Moving the LDPI one mile to the east would make the two production wells planned to target the northwest portion of the field longer. Seismic data interpretation indicates the reservoir is thickest in the northwest portion of the field and thins significantly further down dip in the southeast direction. These two more important producer wells, targeting the thickest reservoir interval would be less efficient due to their increased flowing friction / pressure drop.

Artificial gas lift is planned for the production wells. Injecting gas into the tubing reduces the produced fluid's density and thus the bottomhole flowing pressure, conserving reservoir energy, maximizing its use to further support production rates and ultimate recovery.

Conclusion for Alternative 3A

Each production well's artificial gas lift design and operation would require modification to optimize production rates for the new wellbore lengths.

The aggregate change in wellbore paths for both injectors and producers would have negligible impact on the ability to manage the reservoir and maximize its performance and effective reservoir management planning and execution would optimize the recovery of oil under this alternative. Less drilling waste would be generated for disposal.

None of the wellbores requires unusual directional drilling capabilities or excessive horizontal departures and would have negligible impact on the total time required to drill the proposed wells.

The impact of relocating the LDPI to a site approximately one mile to the east would have little or no impact to the overall production rates, the ultimate economic recovery of hydrocarbons, and resulting cumulative oil production of the Liberty Field reservoir at abandonment is negligible.

Alternative 3B: Relocate LDPI Approximately 1.5 Miles to the Southwest

Alternative 3B places the LDPI approximately 1.5 miles to the southwest closer to shore into State of Alaska (SOA) waters.

Reservoir Access

This alternative would increase the total aggregate measured length for all of the production wells. The three planned producers targeting the southeast portion of the reservoir would have their total aggregate wellbore lengths lengthened by an estimated six thousand feet. The two production wells planned to target the northwest portion of the field would have wellbore paths lengthened an estimated four thousand three hundred and three thousand nine hundred feet.

This alternative would increase the total aggregate measured length for all of the injection wells. The first development well planned to be drilled, a gas injection well to intersect the reservoir at the crest of the structure to the northeast, would be lengthened by an estimated four thousand feet. The three

remaining planned water injectors targeting the center of the reservoir would each be longer by a total aggregate measured length of approximately six thousand feet.

This alternative would allow the Liberty Reservoir to be accessed and produced through conventional slant angle wells directionally drilled from the LDPI surface wellhead locations to reach the full extent of the reservoir with a departure of less than three miles radius. This means that the bottom hole well location would be less than three miles in a horizontal direction away from the well's surface location in order to fully penetrate and help drain the entire reservoir. The resulting well angles all remain below 65 degrees from vertical allowing for standard well drilling, completion, and servicing mechanisms.

Reservoir Depletion

The aggregate increase in the wellbore path lengths for all injectors and producers combined would be approximately twenty-eight thousand eight hundred feet (an estimated 38% of the Proposed Action's planned total wellbore length). As a result of increased wellbore path lengths, more rock cuttings and excess drilling mud would be generated for disposal either by the G&I facility or alternatively transported onshore for disposal. It would take more time to drill, complete, and service these longer wells. As a result of the longer drilling times, production of fluids from the reservoir and initiation of water and gas injection into the reservoir would occur later and field development would take longer.

The longer total aggregate measured length of the flow path for the producers would result in an increased overall pressure drop due to flowing friction up the production tubing. More total reservoir energy would be required to overcome this flowing friction as reservoir fluids are produced.

Moving the LDPI one and a half miles southwest along the planned pipeline corridor would make the two more important producers targeting the thickest portion of the reservoir to the northwest longer. These two producer wells would be less efficient due to the resulting increased flowing friction / pressure drop.

Artificial gas lift is planned for the production wells. Injecting gas into the tubing reduces the produced fluid's density and thus the bottomhole flowing pressure, conserving reservoir energy, maximizing its use to further support production rates and ultimate recovery.

Conclusion for Alternative 3B

Each production well's artificial gas lift design and operation would require modification to optimize production rates for the longer wellbore lengths.

The lengthening of wellbore paths for all injectors and producers would have a negligible impact on the ability to manage the reservoir and maximize its performance and effective reservoir management planning and execution would optimize the recovery of oil under this alternative. More drilling waste would be generated for disposal.

None of the wellbores requires unusual directional drilling capabilities or excessive horizontal departures and would have a negligible to minor impact on the total time required to drill the proposed wells.

The impact of relocating the LDPI to a site approximately one and a half miles southwest along the planned pipeline corridor would have less than severe or little impact to the overall production rates, the ultimate economic recovery of hydrocarbons, and resulting cumulative oil production of the Liberty Field reservoir at abandonment is negligible to minor.

4.2.1.4. Alternative 4 (Alternate Processing Locations)

Under this Alternative, the oil and gas processing facilities would be moved from the LDPI to one of two locations. The Liberty Field reservoir would still be accessed and depleted from wells drilled, completed, and serviced on the gravel island.

Redesigned and increased pumping equipment and capacity as well as an alternative pipeline design would be required to provide the energy to move all the reservoir fluids to the off-island processing facility while returning produced and treated water and gas to the LDPI. Treated produced water augmented by treated seawater would still be required to optimize oil recovery through Enhanced Oil Recovery (EOR) water flooding of the Liberty Field reservoir as described in the Proposed Action. Processed natural gas would still be needed for gas lift operations and gas injection to support resource conservation efforts (produce more oil and leave less oil behind) though gas injection efforts.

Alternative 4A: Relocate Oil and Gas Processing to Endicott SDI

Alternative 4A would move oil and gas processing facilities from the LDPI to the existing Endicott SDI facility.

If appropriate pumping, processing, and return of gas and water EOR fluids for reservoir management is achieved, then the types and potential for impacts to the Liberty Field reservoir due to Alternative 4 development and production operations are not expected to differ from the Proposed Action.

The impact of relocating the oil and gas processing to the Endicott SDI on the Liberty Field reservoir is negligible with little or no impact.

Alternative 4B: Relocate Oil and Gas Processing to a New Onshore Facility

Alternative 4B would move oil and gas processing facilities from the LDPI to new onshore facility.

If appropriate pumping, processing, and return of gas and water EOR fluids for reservoir management is achieved, then the types and potential for impacts to the Liberty Field reservoir due to Alternative 4 development and production operations are not expected to differ from the Proposed Action.

The impact of relocating the oil and gas processing to a new onshore facility on the Liberty Field reservoir is negligible with little or no impact.

4.2.1.5. Alternative 5 (Alternate Gravel Sources)

Under this Alternative, the Proposed Action would be approved and the actions described in the Liberty DPP would take place using alternative gravel sources as described by Alternative 5A, 5B, or 5C. Development plans and production operations would remain the same under Alternative 5A, 5B, and 5C as for the Proposed Action.

The impact to the Liberty Field reservoir is not expected to differ between the Proposed Action and Alternative 5, with the exception of a delay in commencing drilling operations and thus a delay to initial oil production (first oil) due to an extended proposed LDPI construction window if the Alternative 5C gravel source (Duck Island Mine site) is used.

The impact of using alternative gravel sources to the Liberty Field reservoir is negligible with little or no impact.

4.2.2. Water Quality

Impacts under all action alternatives would result in impacts to marine, freshwater, and estuarine water quality during construction, production, and decommissioning. Construction of the LDPI would occur during the winter months thereby minimizing the impacts to water quality. During construction, water quality impacts to freshwater, estuarine and marine environments would largely be a result of

ice roads and pads, gravel mine dewatering, onshore facilities construction, vessel discharge, LDPI and pipeline construction, wastewater discharges and accidental oil spills. The duration for these activities is expected to be short-term and temporary.

The primary source of water quality impacts to marine waters during production would be from the ongoing NPDES-permitted point-source wastewater discharge from the seawater treatment plant. Although HAK intends to discharge the waste streams into an approved UIC disposal well, impacts to marine water quality may occur in the event that the UIC disposal well is unavailable (see Section 2.1.9).

The primary sources of marine, freshwater, and estuarine water quality impacts during decommissioning would result from the rehabilitation of the gravel mine site, the removal of the LDPI slope protection system, onshore facilities and gravel pads.

Assumptions for Water Resources

The State of Alaska Department of Natural Resources (ADNR) regulates and permits many aspects of winter travel on the Alaska North Slope (ANS). The Division of Mining, Land and Water is responsible for permitting ice road construction, while the Water Resources Office (ADNR WRO) regulates temporary water withdrawal (used for onshore ice road construction) from rehabilitated and existing mine sites and tundra ponds. Typically, ADNR WRO allows for a 20% withdrawal of a water resource depending on its location and the habitat it provides, allowing for one or two years to pass between withdrawals for adequate recharge to occur.

HAK currently holds General Land Use Permit #LAS 29963 for ice road and ice pad construction on all STATE OF ALASKA (SOA) owned lands on the ANS bordered by the Canning River to the east and the Colville River to the west and the Brooks Range to the south. HAK estimates that an estimated 20 million gallons would be needed for annual ice road construction and approximately 120 million gallons of freshwater for the two year construction period.

4.2.2.1. The Proposed Action

The Proposed Action's impacts to water quality would result from ice road and pad construction, gravel mine site development, construction of the LDPI and pipeline, and construction of facilities on the proposed LDPI and onshore facilities. Water quality impacts from these activities would be primarily related to temporary increases in turbidity.

Increased turbidity is evidence of an increase in total suspended solids (TSS). TSS is designated as a conventional pollutant (CWA 304(a)(4) and 40 CFR 401.16), not a toxic pollutant. Turbid waters absorb more heat and water holds less dissolved oxygen as temperatures rise (Dodds, 2002). These effects are temporary, decreasing and ending with settlement of the suspended sediments.

Water quality impacts during production would mainly result from point-source discharges from the proposed seawater treatment plant (STP). See Section 2.1.9 for a thorough discussion on the point-source discharges of the STP and the mandatory EPA NPDES permit.

Construction Impacts

Ice Roads and Ice Pads

See Section 2.1.1 for more detail on the Proposed Action's ice road construction and routes. Ice roads and pads would be built during construction and continue to be used throughout production. Spring snowmelt can hasten melting of ice roads and ice pads and result in a temporary increase in turbidity in adjacent wetlands and at stream and river crossings.

Impacts to water quality would be seasonal during spring break-up. Increased turbidity of freshwater and estuarine streams could occur, as well as increased turbidity downstream to marine waters,

including surface, mid-depth, and bottom waters. The increase in turbidity would be temporary. Mitigation typically required by ADNR and NSB permits would include slotting ice roads at stream and river crossings to preclude ice-dam impoundments by providing outlets to allow streams to flow during snow-pack melt and breakup.

Suspended sediments and melt water from ice roads and ice pads may include pollutants from vehicular traffic and ice-pad operations. Pollutants are expected to settle and/or dilute to background levels.

Gravel Mine

All gravel needed to create the proposed LDPI would be obtained from the Proposed Action's new gravel mine site during one winter unless a second year of island construction is needed (Hilcorp, 2015, 2017). A source of approximately 1,250,000 cubic yards of gravel is required to meet immediate and potential long-term project needs.

The proposed creation of the 21-acre gravel mine site would result in a permanent loss of wetlands (Section 4.3.6). Wetland functions that affect water quality such as: maintenance of natural sediment transport processes, production and export of organic matter, and the maintenance of the soil thermal regime would be eliminated within the gravel pit footprint. These impacts are long term, but would be limited in extent to the 21-acre site.

Impacts to freshwater quality could occur from dust generated during mine excavation that would settle on the snow and enter the flows into adjacent lakes or streams during spring break-up. High levels of turbidity in the water column already occur naturally near the Proposed Action Area during spring break-up. The increase in turbidity from dust associated with gravel mining would represent a minor contribution to overall suspended sediments. The ice pad used for stockpiling of overburden from the gravel mine would have impacts similar to ice roads as discussed above.

Poor water quality at the gravel mine site would be avoided by adherence to a Long-Term Adaptive Management Plan, a requirement of ADNR. Regulation of discharges from dewatering the gravel during mining would also serve to minimize impacts to the water quality in adjacent bodies of water.

Onshore Gravel Pad and Related Construction

The Proposed Action requires approximately 3,500 cubic yards (cy) of gravel for the 0.71-acre Badami tie in pad, and approximately 1,500 cy for the 0.15-acre Badami ice road crossing (Hilcorp, 2017, Section 10.3). About one acre of wetlands and their functional value would be permanently lost as a result of the gravel fill.

Vessel Discharge

Vessels >24 m (79 ft.) in length operating as a method of transportation would require NPDES permit coverage for incidental discharges under the Final 2013 Vessel General Permit for Discharges Incidental to the Normal Operation of Vessels (VGP) (EPA, 2013). The VGP establishes effluent limitations to control materials that contain constituents of concern in the waste streams from vessels. Pollutant constituents in the VGP's may include nutrients, pathogens, oil and grease, metals, biochemical oxygen demand, pH, total suspended solids, aquatic nuisance species and other toxic and non-conventional pollutants with toxic effects. In addition to complying with NPDES requirements, vessels discharging in the contiguous zone and ocean (seaward of the outer limit of the territorial seas) are subject to MARPOL 73/78, implemented by the USCG pursuant to 33 CFR 151. Vessels <24 m (79 ft) in length that are operating as a method of transportation may be covered under the VGP, or may instead opt for coverage under the small VGP (sVGP) issued by the EPA.

Proposed LDPI and Pipeline Construction

Construction of the proposed LDPI is planned for a one-year period, with gravel placement commencing the first winter of the development. Should the winter season be shortened by warm air temperatures thereby reducing the useful life of the ice road, it may become necessary to extend the island construction period to two years (Hilcorp, 2017). Approximately 927,000 cubic yards of gravel would be needed to construct the proposed LDPI. Gravel placement operations would begin following ice road construction and artificial ice thickening at the island site. Gravel would be hauled from the gravel site on the proposed ice road to the island site for approximately 50–70 days ending by mid-April, weather conditions permitting.

During the process of construction, sections of sea ice would be cut and removed over the location of the island. Once the ice is removed, gravel would be poured through the water column to the sea floor, building the island structure from the bottom up (Hilcorp, 2015, page 54.). A conical pile of gravel will form on the seabed floor until it reaches the surface of the ice. The construction would continue with a sequence of removing additional ice and pouring gravel until the surface size of 9.3 acres is achieved. It is estimated that the footprint of the island at the seafloor would be approximately 24 acres (Hilcorp, 2015, page 54).

The regional circulation pattern within Foggy Island Bay would not be notably altered by the presence of the completed LDPI. The predominate east-west winds in this area are the overwhelming driving force of the west-east currents measured from comparing Acoustic Doppler Current Profilers (ADCP), land based High Frequency Radars, and coastal meteorological stations (Weingartner et al, 2009; Potter and Weingartner, 2009). During the summer months ocean currents will be advected to the west-northwest around the island due to winds from the east. Likewise when winds are from the west, currents will move around the island to the southeast. Therefore, BOEM does not expect the regional circulation to change for Foggy Island Bay due to the presence of the completed LDPI.

Proposed LDPI construction and installation of the subsea pipeline from the mainland to the LDPI are expected to increase sediment load in the water column. Reduction of light penetration by increased suspended sediment concentrations resulting from construction activities is of concern because of the close proximity of the proposed Project Area to the kelp beds resident in the Stefansson Sound Boulder Patch. In an effort to understand the generation and distribution of excess suspended sediment (XSS) on the Stefansson Sound Boulder Patch, Coastal Frontiers (2014) modeled the expected turbidity plumes and the effects of increased suspended sediment for winter/spring and summer construction scenarios. The XSS is the amount of excess suspended sediment determined to be above the ambient TSS at a location given the season and weather conditions. The XSS includes the sediment that is transported away from the excavation site by the ambient current (Ban et al., 1999). The scenarios under consideration included:

- Winter Island Gravel Placement
- Spring Island Slope Grading and Armoring
- Winter Pipeline Installation
- Summer Wave Winnowing, Island Slope Grading and Armoring
- Summer Wave Degradation of the Pipeline Backfill Mound

For the purposes of this analysis, only the data and graphics from the westerly currents that could potentially have suspended sediment impacts to the Stefansson Sound Boulder Patch have been included. BOEM understands that easterly flowing currents would produce a XSS plume east of the proposed Project Area. However because westerly flowing currents occur on the average 60 to 70% of the time (Ban et al, 1999) the impacts analysis provided is considered conservative and worse-case.

Winter/Spring Construction Scenarios

During the winter/spring season, the nearshore waters of Foggy Island Bay are covered in ice sheets up to 6 feet deep (Coastal Frontiers, 2014). These ice sheets create a barrier to the winds resulting in low under-ice currents. The average current speed observed during the ice-covered season in the Project Area is 0.04kt (2cm/s) (Ban et al., 1999). The lack of wind-driven current and wave action results in naturally low sediment resuspension and turbidity levels. TSS concentrations during the ice-covered periods range from 0.1 mg/L to 0.6 mg/L in the Arctic Nearshore Impact Monitoring in Development Area (ANIMIDA) study area during 2001 and 2002 (BOEHM et al., 2001).

To estimate the suspended sediment concentrations and turbidity plumes for the construction of the LDPI, Coastal Frontiers (2014) refined the general methods used by Ban et al. (1999) in a previous study on an earlier proposed Liberty project. In both studies, Ban et al., (1999) and Coastal Frontiers (2014), placed particular emphasis on defining the area of the Stefansson Sound Boulder Patch impacted by increased TSS concentrations in excess of 10 mg/L, the threshold value assumed to negatively impact winter kelp growth.

The TSS concentrations and the nature of the plume are dependent on, 1) the properties of the gravel fill, 2) the rate of fine particle introduction to the water, 3) the water depth, 4) current speed, and 5) current direction (BPXA, 1998). Values for these variables are provided in the report for each scenario along with the assumptions used in the modeling. Initial concentrations of suspended sediments for each scenario were calculated based on these values and assumptions. For a full description of these values and assumptions, see Coastal Frontiers (2014) and Ban et al. (1999).

During island gravel placement, a large portion of the suspended material would settle to the seafloor within or adjacent to the footprint of the island, while the finer fractions (<75 µm) are expected to be transported as a plume to the southeastern section of the Stefansson Sound Boulder Patch (Coastal Frontiers, 2014). The initial increase of TSS at the LDPI site is expected to be 250 mg/L (Ban et al., 1999). Figure 4.2.2-1 presents the anticipated sediment plume under the westerly flowing currents and illustrates the cone shape plume with segments indicating the reach of 100 mg/L, 50 mg/L, 20 mg/L and 10 mg/L of XSS.

The initial turbidity plume disperses below 10 mg/L within about 10,000 ft. from the LDPI. The impact of winter LDPI construction would result in temporary (35 days maximum exposure) XSS increase (100 mg/L to 10 mg/L) that would settle quickly from the origin at the proposed LDPI to the farthest calculated reach of the turbidity plume. Should the construction of the LDPI take two consecutive winters to complete, BOEM expects the impact to be similar in magnitude and duration.

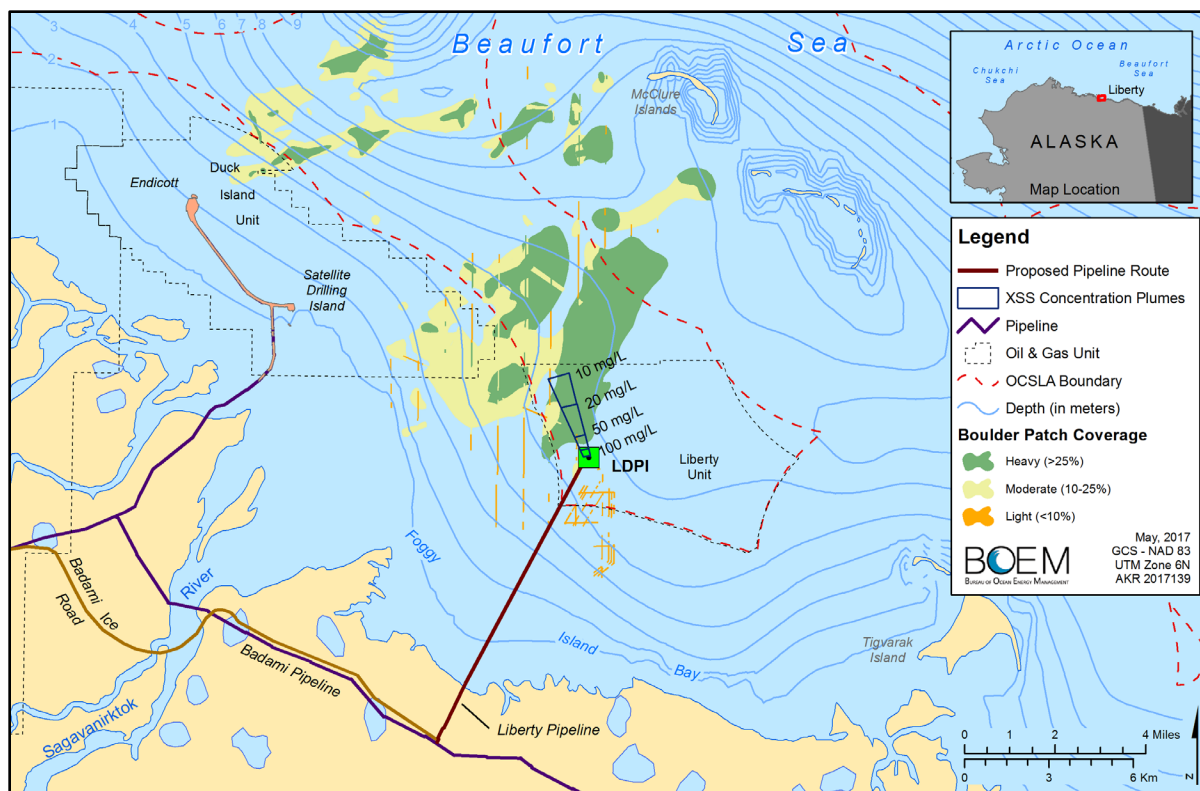

Figure 4.2.2-1. XSS Concentrations and Affected Boulder Patch Areas-LDPI Winter Construction (Coastal Frontiers, 2014, Figure 7).

Spring Slope Grading and Armoring

Following completion of the winter gravel haul, grading of the exposed gravel slopes of the LDPI would be performed. The grading process utilizes a crane and dragline to reshape and prepare the LDPI perimeter for installation of the slope armor system (Coastal Frontiers, 2014). Performing the grading and armoring during the later spring through a moat from which sea ice has been removed, allows the side slope profiles to be shaped to their final configuration and armored in the absence of waves and currents (Coastal Frontier, 2014). Should a second season of island construction be required, temporary slope protection would be installed for that portion of the island for which gravel placement was not completed (Hilcorp, 2017).

The anticipated turbidity plume would impact a smaller area for a shorter duration than the plume resulting from winter construction of the LDPI (Figure 4.2.2-2). Figure 4.2.2-2 illustrates a 75-acre, cone-shaped plume projecting from the LDPI and the reach of the 100 mg/L, 50 mg/L-, 20 mg/L, and 10 mg/L areas of XSS (Coastal Frontiers, 2014). Plume exposure would be limited to approximately 23 days (Coastal Frontiers, 2014). The initial XSS concentration of 598 mg/L (based on assumptions derived from earlier modeling efforts (Ban et al., 1999)) from the dragline construction activities would dissipate relatively quickly (100 mg/L to 10 mg/L) from the origin to the farthest calculated reach of the turbidity plume at 4,000 ft from the LDPI (Coastal Frontiers, 2014). Once the slope protection system is installed during either the first or second open-water season, the LDPI gravel would no longer contribute to XSS (Coastal Frontiers, 2014). Should the construction of the LDPI take two consecutive winters to complete, BOEM expects the impact to be similar in magnitude and duration.

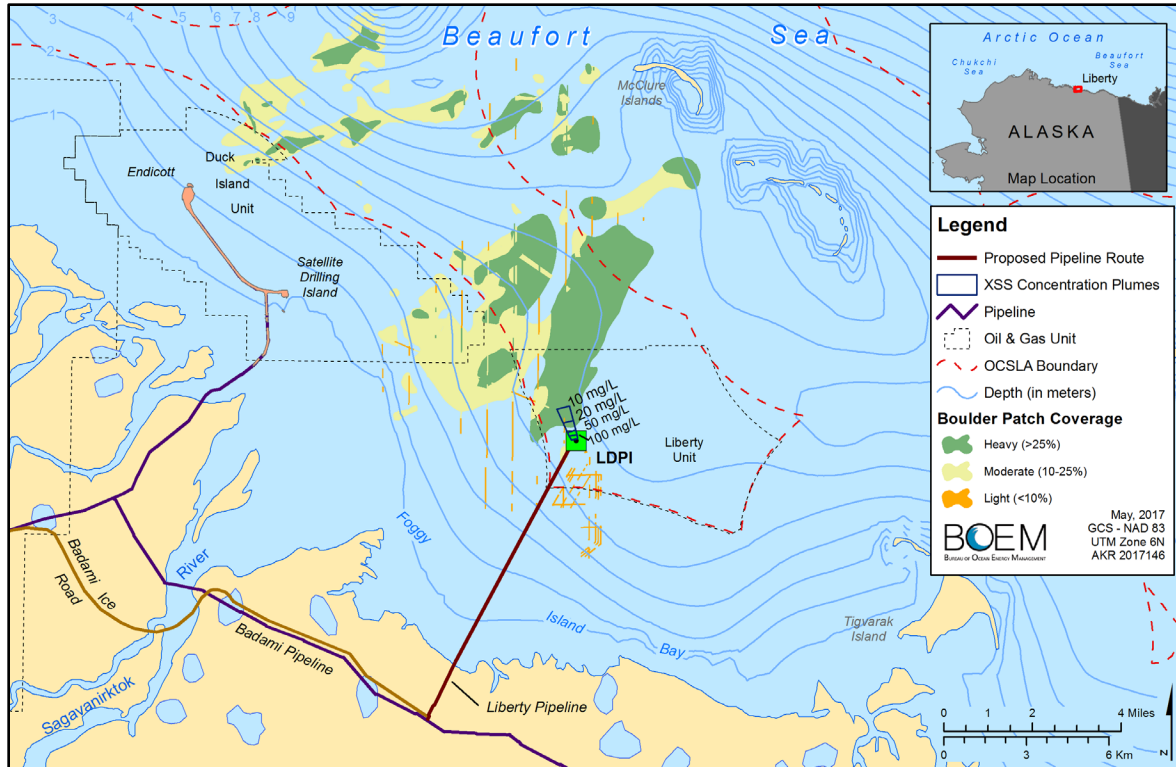

Figure 4.2.2-2. XSS Concentrations and Affected Boulder Patch Areas During Spring Moat Dragline Operations at the LDPI Source: *Coastal Frontiers (2014, Figure 13).*

Winter Pipeline Installation

The proposed pipeline connecting LDPI to the onshore facilities would be installed during winter following construction of the island. Pipeline installation would include seabed trench excavation through a slot in the ice sheet, placement of the pipeline and backfill of the native material on top of the installed pipeline (Coastal Frontiers, 2014).

Reportedly, the top 5m of the seabed material is comprised of 88% fines content (Coastal Frontiers, 2014). The distribution of these seabed fine materials would be significantly different than the fines distribution for the gravel island fill [fines content at 10% (Coastal Frontiers, 2014)]. Consequently, greater percentages of seabed material would remain suspended longer and can be transported further from the pipeline alignment (Coastal Frontiers, 2014). Approximately half of the pipeline alignment route would be in grounded ice due to shallow water depths landward of the LDPI (Coastal Frontiers, 2014). The anticipated turbidity plume would, therefore, be generated from only that portion of the pipeline exposed to open water.

Suspension of the fine fractions of sediment would occur during the trench excavation and the backfill of the excavated material into the pipeline trench. The sediment plume from the trench excavation would be short-lived, lasting less than 3 days for the deepest portions of the pipeline. Initial resuspended sediment concentrations would range from 1,671 mg/L near the LDPI, to 7,160 mg/L at the approximate midpoint of the pipeline route to shore (Coastal Frontiers, 2014). Figure 4.2.2-3 illustrates the maximum concentration of the XSS plumes for the excavation activity under westerly current conditions. The irregularly shaped plume extends over 991 acres of the southeastern portion of the Stefansson Sound Boulder Patch in reaches of 100 mg/L, 50 mg/L, 20 mg/L, and at the furthest reach, 10 mg/L of XSS. The cross hatching on Figure 4.2.2-3 indicates the landward portion of the proposed pipeline where construction activities would take place in grounded ice. No

suspended sediments are expected to occur from this portion of the pipeline due to the absence of water and currents.

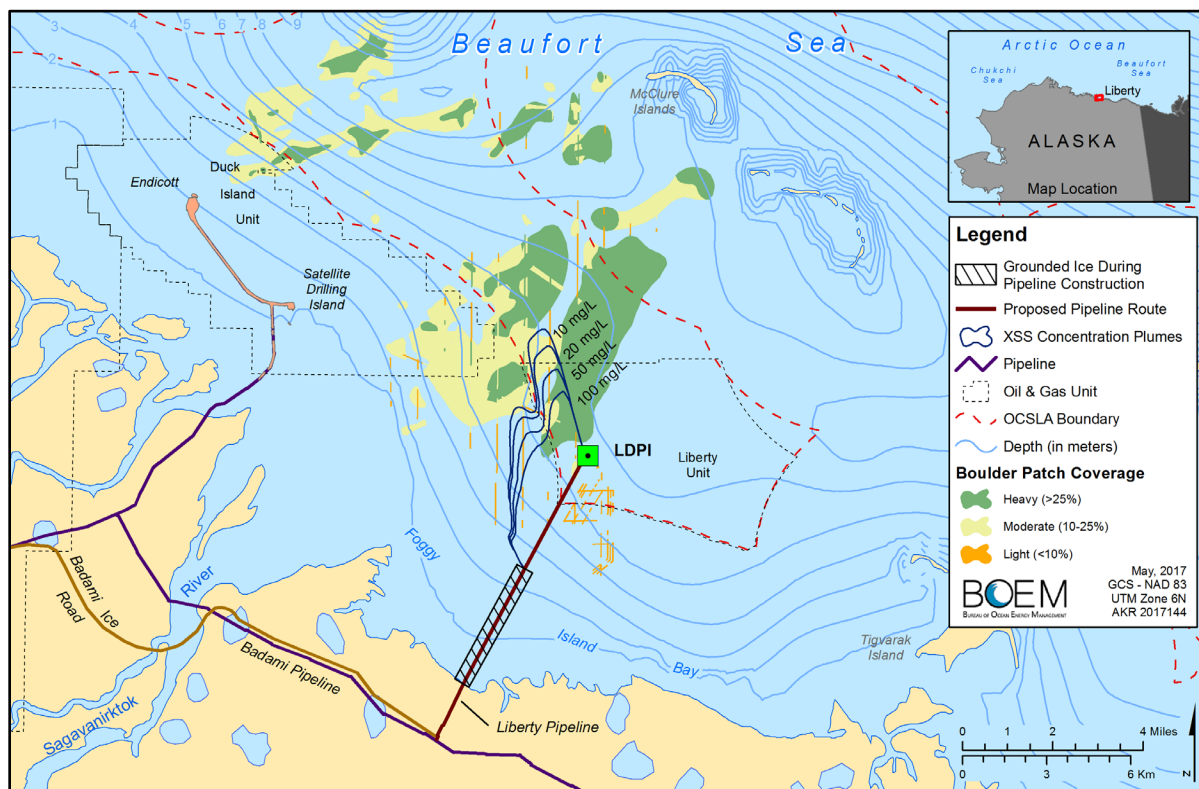

Figure 4.2.2-3. XSS Concentrations and Affected Boulder Patch Areas During Winter Pipeline Trench Excavation, Westerly Current (Coastal Frontiers, 2014, Figure 9)

Backfill of the excavated trench would be conducted following installation of the subsea pipeline over a period of approximately 7 days (Coastal Frontiers, 2014). During the backfill of the pipeline trench, 2% of the entire sediment volume is estimated to be suspended into the water column based on previous North Slope subsea pipeline installations and assumes that the backfill is frozen prior to being placed into the trench. Although a significantly smaller fraction of fines is introduced into the water column during the backfill activities, the spatial extent of the XSS plumes are still quite large. The trench backfill XSS concentration impacts 679 acres of Stefansson Sound Boulder Patch and the initial concentrations of XSS are estimated at 301 mg/L to 1,289 mg/L depending upon the effective water depth at each backfill region (Coastal Frontiers, 2014). The maximum time of exposure ranges from 18 to 53 hours (Coastal Frontiers, 2014).

Figure 4.2.2-4 shows the anticipated XSS plumes from the winter trench backfilling activities under the westerly wind conditions. As stated previously, the conditions depicted in Figure 4.2.2-3 and Figure 4.2.2-4 are relevant when the ocean currents are westward, which occurs on average 60–70% of the time (Ban et al., 1999).

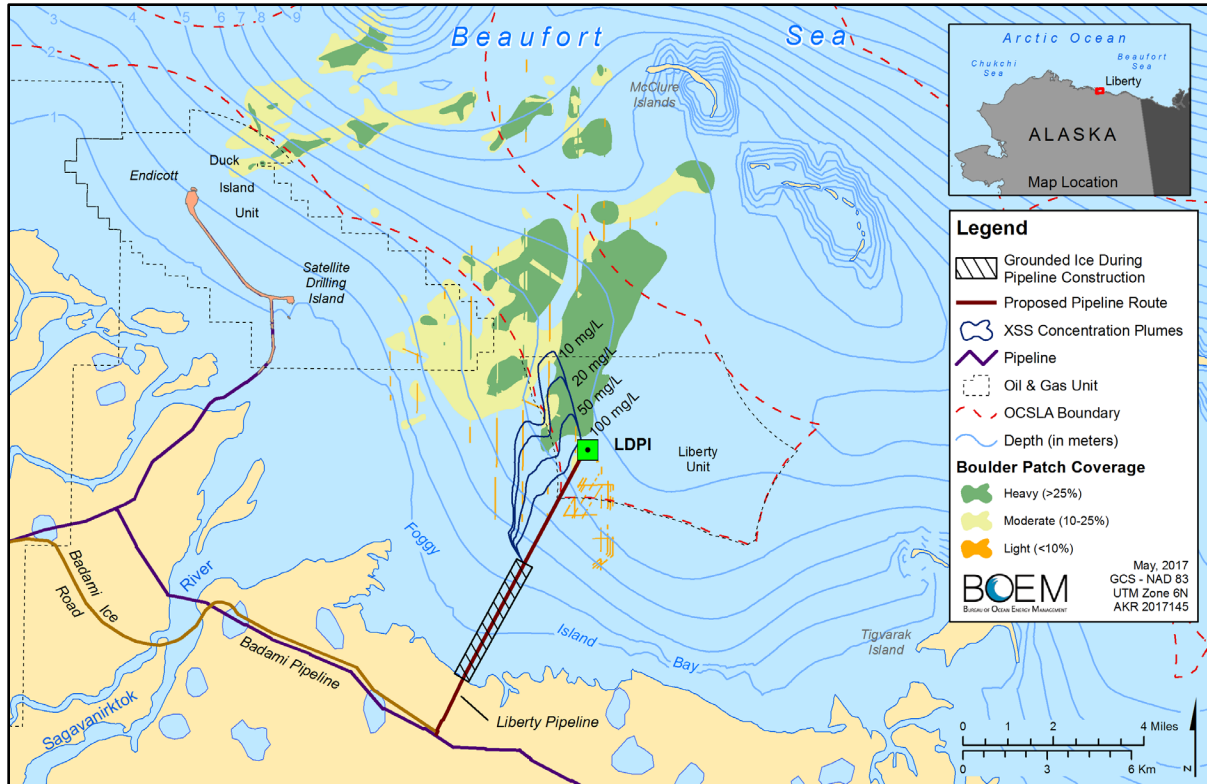

Figure 4.2.2-4. XSS Concentrations and Affected Boulder Patch Areas during Winter Pipeline Trench Backfill, Westerly Current Source: Coastal Frontiers (2014, Figure 11).

Summer Wave Winnowing, Island Slope Grading and Armoring

The summer following construction of the LDPI, side slope armoring and armor installation would continue until completed. Open-water conditions would allow waves to winnow fine-grained sediments from the gravel fill on the unarmored portions of the slopes, and variable wind/wave-driven currents would disperse the suspended sediments into the marine environment. Coastal Frontiers (2014) modeled the anticipated plumes associated with both the wave winnowing and the island slope grading and armoring for XSS concentrations of 1, 5, 10, 15 and 20 mg/L. A probabilistic wind method based on historic wind speeds in the vicinity of the project was used for the analysis.

The results of this study showed that the largest area of Stefansson Sound Boulder Patch impacted was 441 acres for approximately 10 days at the 1 mg/L concentration level (Figures 4.2.2-5 through 4.2.2-9; Coastal Frontier, 2014, Figures 14–18).

Summer Wave Degradation of the Pipeline Backfill Mound

During the summers following the completion of pipeline construction, a backfill mound of semi-frozen seabed material over the pipeline would rise above the surrounding seafloor. Warmer summer waters would thaw the mound, and waves and wind-driven currents would degrade the mound until it conforms to the grade of the surrounding seafloor. Coastal Frontiers (2014) used the Probabilistic Wind Method to project the dispersal of XSS from the pipeline backfill mound. Figures 4.2.2-5, 4.2.2-6, 4.2.2-7, 4.2.2-8, and 4.2.2-9 show the dispersal areas for the 1, 5, 10, 15, and 20 mg/L XSS concentrations for this activity.

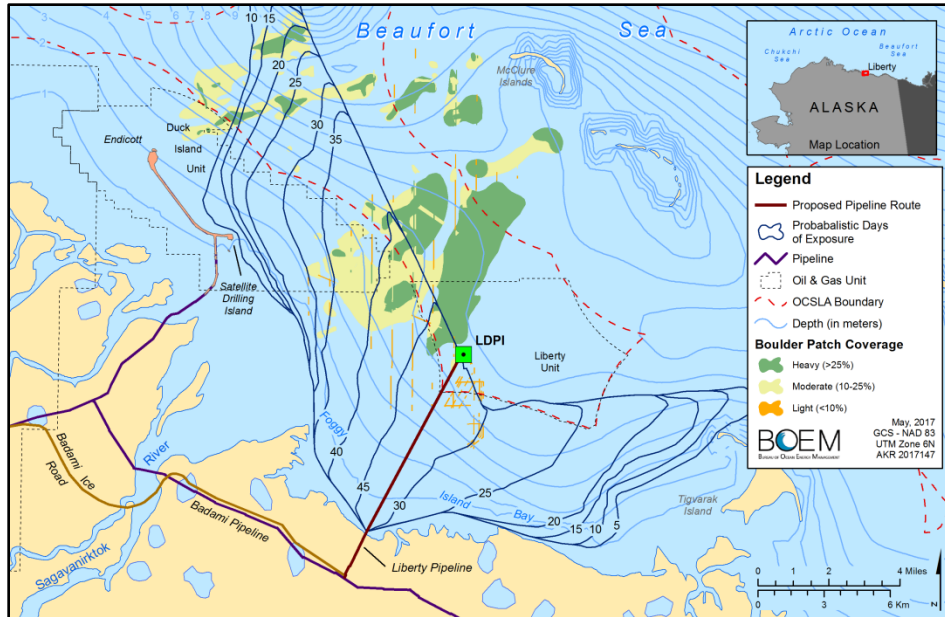

Figure 4.2.2-5. Affected Boulder Patch by 1 mg/L XSS from Backfill Mound Degradation.
 Units are Probabilistic Days of Exposure. Source: Coastal Frontiers (2014, Figure 19).

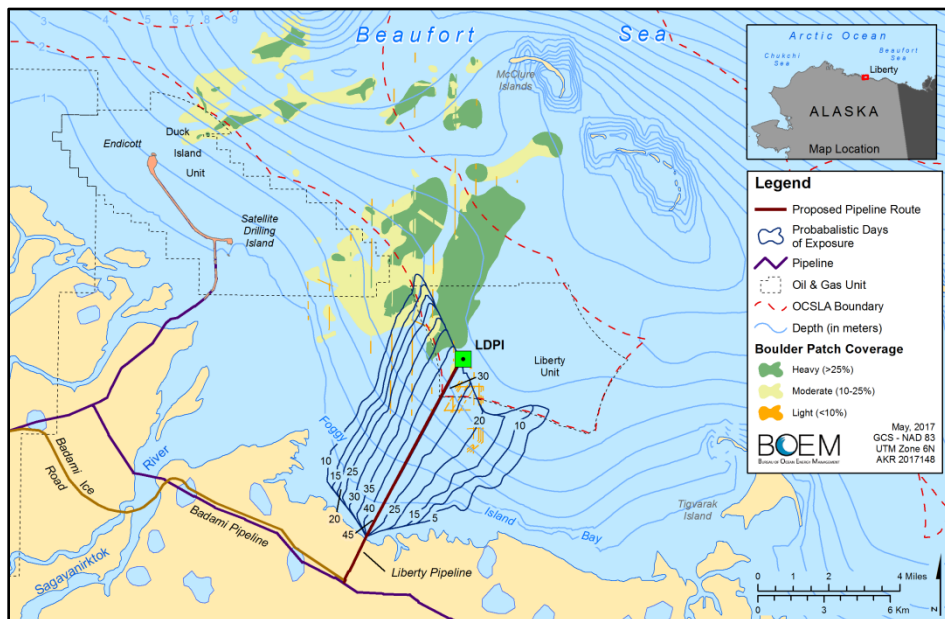

Figure 4.2.2-6. Affected Boulder Patch by 5 mg/L from Backfill Mound Degradation.
 Units are Probabilistic Days of Exposure. Source: Coastal Frontiers (2014, Figure 20).

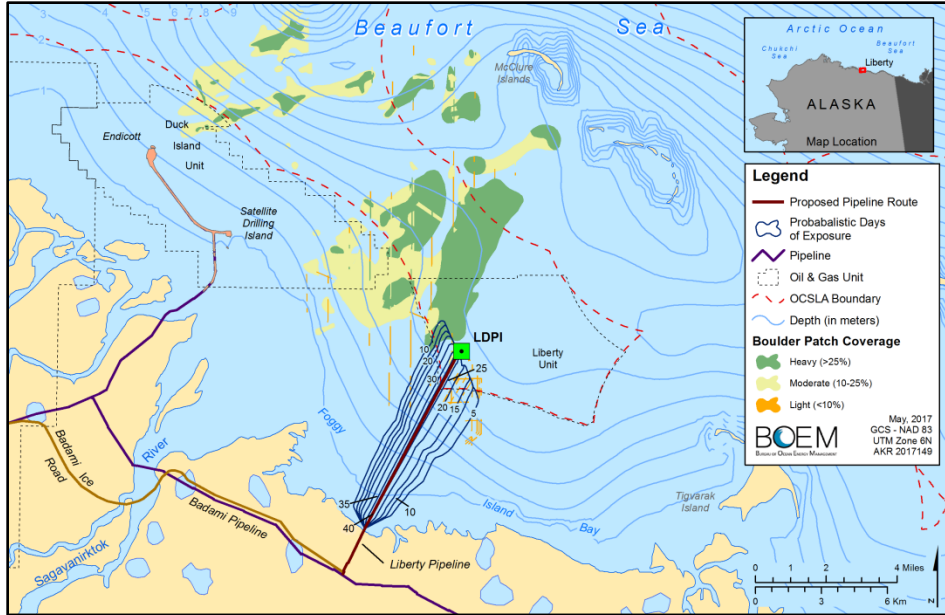

Figure 4.2.2-7. Affected Boulder Patch by 10 mg/L XSS from Backfill Mound Degradation. Units are Probabilistic Days of Exposure (Coastal Frontiers, 2014, Figure 21).

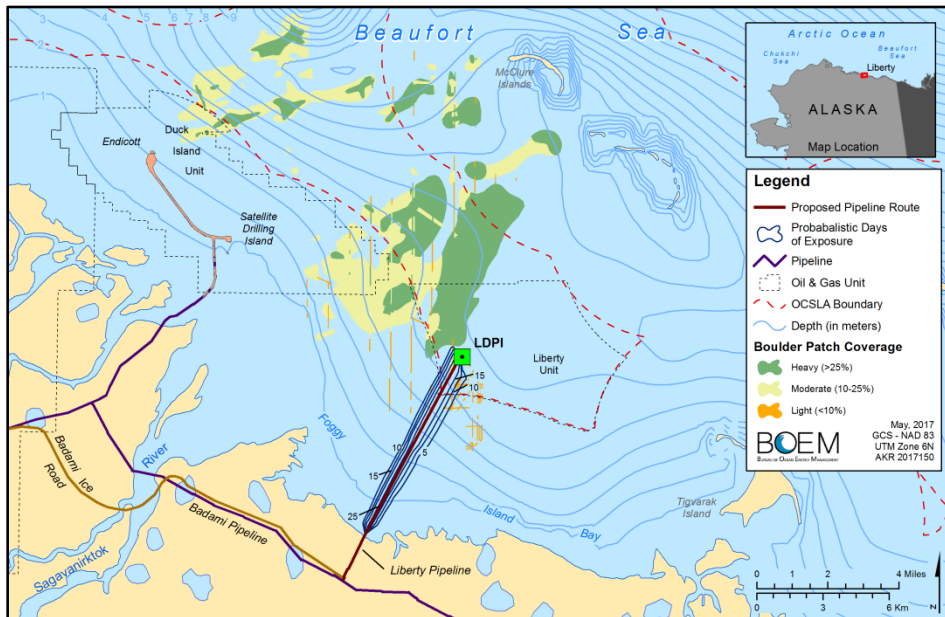

Figure 4.2.2-8. Affected Boulder Patch by 15 mg/L XSS from Backfill Mound Degradation. Units are Probabilistic Days of Exposure (Coastal Frontiers, 2014, Figure 22).

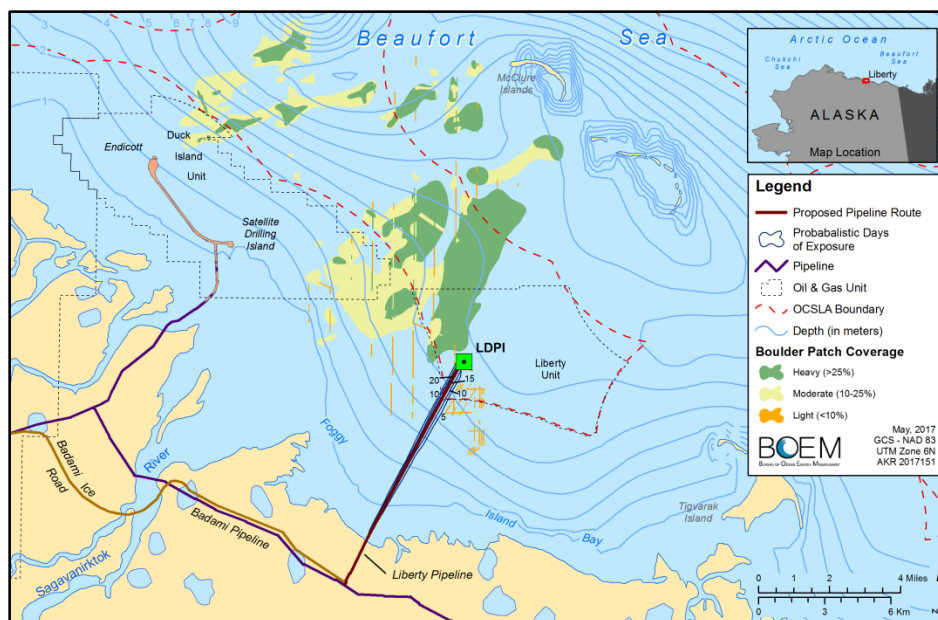

Figure 4.2.2-9. Affected Boulder Patch by 20 mg/L XSS from Backfill Mound Degradation.
Units are Probabilistic Days of Exposure (Coastal Frontiers, 2014, Figure 23).

The summer dispersal of the backfill mound would impact the largest region of the Stefansson Sound Boulder Patch as the mounded backfill material erodes to the approximate elevation of the surrounding seafloor (see Figures 4.2.2-5 and 4.2.2-6). Although large in overall size, the XSS values are estimated to be 1 mg/L and 5 mg/L. Summer wind-driven currents are larger, the seabed material contains a higher percentage of fine-grained sediments (80%) and the northerly portion of the pipeline route traverses across a small section and is in close proximity to the southeast boundary of the Stefansson Sound Boulder Patch (Coastal Frontiers, 2014).

Wastewater Discharges

During construction at the LDPI, there would be no discharges of sanitary and domestic wastewater, potable water reject wastewater, or seawater treatment plant wastewater. However, HAK anticipates discharging construction dewatering wastewater and secondary containment dewatering wastewater intermittently.

During construction of the project, sanitary and domestic wastewater would be hauled offsite to an onshore disposal facility and potable water would be brought to the project location from an existing onshore source. The STP facility installation on the LDPI would not begin until late in the second year or early in the third year of the project. For purposes of this analysis, EPA assumes that discharges from the STP would not occur until construction has been completed and production activities have been initiated.

The only wastewater discharges from the LDPI during development construction would be from construction dewatering and secondary containment dewatering. No discharge volumes have been specified for either the construction dewatering or secondary containment dewatering discharges because the volume and frequency is driven by storm events and seasonal snowmelt during the spring thaw (May-June). The pollutants associated with these discharges may include TSS and oil and grease. Total aromatic hydrocarbons (TAH) and total aqueous hydrocarbons (TAqH) may be present in the secondary containment dewatering wastewater if there are storage tanks containing bulk fuel and petroleum products.

Since the waste streams would be discharged on an infrequent basis during construction prior to the availability of the UIC disposal well, any impacts to water quality would be intermittent, localized,

and short-term in nature. This conclusion takes into consideration that the discharges of construction dewatering and secondary containment dewatering are short term and infrequent, and subject to the terms and conditions of the NPDES permit. EPA's analysis and determinations within the ODCE concludes there would be no unreasonable degradation of the marine environment as a result of these NPDES discharges. Additionally, construction activities are scheduled to occur during winter months when marine productivity is lowest and photosynthetic opportunity is minimal.

Accidental Oil Spills

Accidental discharges of crude, refined oil, or other petroleum products that reach the marine environment would affect water quality by introducing chemical pollutants into the water. The Alaska State Water Quality Standards (WQS) applicable ambient-water-quality standards for "Petroleum Hydrocarbons, Oils and Grease for Marine Water Uses" is provided below and is found in the State of Alaska Chapter 18 AAC 70, Water Quality Standards (ADEC, 2016):

- Total aqueous hydrocarbons (TAqH) in the water column may not exceed 15 micrograms per liter (15 µg/L).
- Total aromatic hydrocarbons (TAH) in the water column may not exceed 10 micrograms per liter (10 µg/L).
- There may be no concentrations of petroleum hydrocarbons, animal fats, or vegetable oils in shoreline or bottom sediments that cause deleterious effects to aquatic life. Surface waters and adjoining shorelines must be virtually free from floating oil, film, sheen, or discoloration

The WQS provide for both quantitative criteria for TAqH and TAH and qualitative criteria for observable oils in both waters and sediments. The numeric criteria of 10 µg/L (TAH) and 15 µg/L (TAqH) are protective of the marine water use class for the "Growth and Propagation of Fish, Shellfish, Other Aquatic Life, and Wildlife", the highest use class designated for the SOA waters. Background concentrations of hydrocarbons in the Beaufort Sea are generally less than or equal to 1 µg/L, or about 15 times less the SOA's more stringent water quality criterion of 15 µg/L for TAqH.

Small Oil Spills

Small refined (e.g., diesel fuel) oil spills could occur throughout the Proposed Action from drilling rigs and support vessels. Refined oils such as gasoline and diesel are not persistent, do not form emulsions, and usually evaporate rapidly provided they are exposed to air. Refined oils contain only light fractions and primarily weather through evaporation. Evaporation increases with temperature and as wind speed increases.

Small spills reaching the water may be contained by booms or absorbent materials. The impacts to water quality from small refined oil spills include contamination of the surface water by hydrocarbons causing potential short-term levels of toxicity in the immediate vicinity of the small spill.

The fate of a small diesel spill would depend on meteorological and oceanographic conditions at the time of the event. As noted in Section 3.1.2.1, the ocean currents in Foggy Island Bay are primarily wind driven. Depending on wind direction and speed, water in the vicinity of LDPI would be transported through the barrier islands within 1-2 days (Figures 3.1.2-3 and 3.1.2-4). A small spill is unlikely to persist long enough to be transported through the barrier islands. For small spills occurring under broken-ice conditions, more oil would remain in the water compared to the same time intervals for open-water spills because of adherence to the ice and diminished wind effects related to shorter fetch between iced areas. The water quality effects of a spill occurring under broken-ice conditions would endure longer than those for an open-water spill.

A meltout spill occurs during the transition period from frozen to open-water conditions. If a spill occurred in broken-ice conditions as the winter season is beginning or occurs on ice, oil could be frozen into the ice. When melting begins, the unweathered oil would enter the water column. As the

ice melts, water temperatures increase and the winds play an increasing role in generating currents and waves because of more open water. With these changes, oil evaporation and dispersion rates would approach those of the open-water conditions.

If a small spill occurs under the ice, the oil would become frozen into the ice and not weather until meltout begins. The processes affecting oil and the concentrations of hydrocarbons dispersed in the water would be the same as those described for a meltout spill. Small spills of crude oil would persist longer in the environment and could result in greater impacts than spills of refined products because small spills of crude oil likely would be transported farther and affect larger area of the water column. A small crude oil or condensate spill in open water would introduce hydrocarbon pollutants of various weights into the surface water, causing a temporary decrease in water quality and conditions for potential toxicity. Lighter weight hydrocarbon fractions would volatilize more rapidly than heavier hydrocarbon fractions; however, lighter weight fractions on the water surface would present greater potential for toxicity for surface-dwelling organisms. During ice season, small crude oil and condensate oil spills could affect the localized surface quality of ice and surface water quality if the spill occurred in broken ice.

The magnitude of the impacts would depend on the specific location affected and the nature and magnitude of the activity/accident; however small spills would be expected to result in short term minor impacts to small areas.

Large Oil Spills

Hydrocarbons spilled into the ocean can behave in several ways depending on the types of hydrocarbon compounds and the depth and temperature at which the spill occurs. Hydrocarbons can volatilize into the air, dissolve into the water column or water surface, oxidize via ultraviolet radiation or microbial activity, emulsify and float, or sink to the subsurface, depending on the water uptake plus initial density of the spilled oil (NRC, 2003). Water quality would be affected by hydrocarbons until the processes of dispersion, dilution, degradation, and weathering reduce oil concentrations.

Hydrocarbon concentrations in water have been measured during oil spills that indicate generally rapid removal of hydrocarbons from the water column. The concentration of dissolved and dispersed oil within the upper water column under the spreading oil slick of the Exxon Valdez Oil Spill was estimated to be 800 ppb in the top 10 m using the NOAA oil weathering model corresponding to less than 0.1% of the volume of water in Prince William Sound (Wolfe et al, 1994). More than 90% of the water samples from the spill path analyzed for hydrocarbons contained <1 ppb total PAHs one month after the spill. A month after the spill, most water samples contained <0.1ppb total PAHs (Wells, Buler, and Hughes, 1995). Total PAHs in 45 seawater samples collected between May and October 2010 during the Deepwater Horizon Oil Spill averaged 47 ppb (Sammarco et al., 2013). In more than 6,000 whole unfractionated offshore water samples, 85% were at or near background levels for total PAH concentrations, <0.1ppb.

In an oil slick, it is usually the aromatic volatiles that are the most toxic and of more concern. In situ, cold-water measurements demonstrate that it takes hours to several days for individual compounds of an oil slick to significantly decrease in concentration. However, the bulk of these volatile compounds diminish in less than 3 days, and therefore, it is the 3-day trajectories that have been judged the appropriate length of time to approximate the initial, higher toxicity of spills' in Alaskan waters (Payne et al, 1984).

Decomposition and weathering processes for oil are much slower in cold waters than in temperate regions. Oil weathering rates are slower because there is less evaporation loss. If oil is spilled under sea ice, a decrease in the rate of emulsification stemming from reduced wave-action occurs, compared to open-water conditions (Barber et al., 2014). Prudhoe Bay crude remained toxic to zooplankton in freshwater ponds for 7 years after an experimental spill, demonstrating persistence of toxic-oil

fractions or their weathered and decomposition products (Barsdate et al., 1980). In marine waters, advection and dispersion would reduce the effects of release of toxic oil fractions or their toxic degradation products, including products resulting from photo-oxidation. Isolated waters of embayments, shallow waters under thick ice, or a fresh spill in rapidly freezing ice however, would not be subject to advection and dispersion. An oil spill that occurs in broken ice or under pack ice during the deep winter would freeze into the ice, move with the ice and melt out of the ice the following summer. Spills in first-year ice would melt out in late spring. Spills released from the ice would be unweathered and have the characteristics of fresh oil.

Impacts of the Proposed Action on water quality though localized would remain for a longer term over larger area than a small spill; the resulting larger impact is moderate for a large spill. For a more thorough explanation of the fate and behavior of an oil spill, refer to section 4.5.4 Fate and Behavior of an Oil Spill.

Production Impacts

Wastewater Discharges

The first well to be drilled at the LDPI would be a disposal well. HAK has stated that the drilling waste generated from this activity would be containerized onsite until the disposal well is available, or transferred to a shore-based facility. Once the disposal well is completed, all drilling wastes would be injected downhole. There would be no discharge of drill cuttings, drilling fluids, or other wastes associated with drilling the injection or production wells, and the NPDES permit does not authorize these discharges.

As discussed in Section 2.1.9., once the disposal well is available, and the facility installation processes have been completed, the sanitary and domestic wastewater, potable water treatment reject wastewater, construction dewatering wastewater, and the secondary containment dewatering wastewater would be injected into the disposal well. Although HAK does not intend to discharge these waste streams to the receiving environment, they have requested authorization from EPA on a contingency basis, in the event that the disposal well is unavailable. The seawater treatment plant wastewater discharge would be the only ongoing discharge from the LDPI, which would begin after construction has been completed.

In the event that the disposal well is unavailable, the contingency waste streams may be discharged to the receiving environment. However, the resulting impacts to water quality are expected to be intermittent, localized, and short-term in nature, and all discharges would be required to meet the terms and conditions of the NPDES permit.

The primary source of water quality impacts from NPDES discharges during production is from TSS associated with operation of the STP. TSS is a non-toxic conventional pollutant that naturally occurs in the water column and local benthic sediments. Any TSS-related impacts from the STP discharge are expected to be intermittent and localized because local tidal movements and currents are expected to rapidly dilute and disperse elevated concentrations of TSS to background levels. TSS does not bioaccumulate or persist in the environment. In addition, the concentration and quantity of TSS discharged from the STP is not expected to be great enough to result in significant smothering of sessile marine organisms such as those occurring in the Stefansson Sound Boulder Patch, or to significantly reduce the photosynthetic opportunities of marine organisms on a large scale. Therefore, negligible to minor impacts to water quality are anticipated as a result of the NPDES-permitted discharges during production at the LDPI. This conclusion takes into consideration the terms and conditions of the NPDES permit and analysis and determinations within the ODCE, which concludes there would be no unreasonable degradation of the marine environment as a result of NPDES-permitted discharges.

Other potential impacts to water quality during production include seasonal ice roads, water extraction, gravel mine dewatering and incidental oil/pollutant discharges. These same impacts have been evaluated and analyzed above under the Construction section.

Decommissioning

Project decommissioning activities that have a potential to impact water quality include:

- Rehabilitation of the gravel mine site
- Decommissioning the LDPI, subsea pipeline, and onshore facilities

Rehabilitation of Gravel Mine Site

When mining at a site is completed and connected to a channel, the connection may be either permanent or temporary. In the case of a permanent connection, the site is connected to the river or stream regardless of water level in the river or stream. For a temporary connection, the site is connected to the river or stream only during high water. Connections with a river or stream may include either (1) inlet and outlet connections to allow stream or river water to flow through the site or (2) a single connection that allows stream or river water to flow into the site during flooding or out, when water levels in the site are higher than in the river or stream. Erosion could enlarge the connecting channels and divert more water from the stream/river through the site. During floods, some of the increased flow in the stream/river may divert through the site. The rehabilitation of the gravel mine site would be performed and approved by the appropriate regulatory state agencies.

Decommissioning LDPI, Subsea Pipeline, and Onshore Facilities

Decommissioning and removal of the LDPI slope protection system would expose the island gravel fill material to erosion by ice, waves, and currents. Exposed fine-grained particles would be resuspended resulting in an increase in turbidity in the water column. Heavier materials would settle rapidly from the water column while finer-grained materials would be transported over some distance before settling to the seafloor. Transport distances of finer-grained materials would be a function of the strength of the ambient currents and settling rates of the clasts, but are not expected to exceed EPA's water quality criterion for solids and turbidity: "Settleable and suspended solids should not reduce the depth of the compensation point for photosynthetic activity by more than 10% from the seasonally established norm for aquatic life" (EPA, 1986). Abandonment activities are not expected to introduce or add any chemical pollutants.

After the pipeline is cleaned, decommissioned, capped on both ends and left in place no water quality impacts would be expected.

Onshore facilities and gravel pads would be removed. Localized impacts from erosion of exposed fine-grained particles would be temporary and stabilized by restoration efforts. Loss of wetland function at the sites of onshore facilities would affect small areas and would likely be permanent. In cases on the North Slope where gravel pads have been removed, vegetated wetlands seldom return. The sites usually become either an upland characterized by vegetation adapted to dry conditions or an unvegetated pond.

Conclusion

The primary impacts to water quality as a result of the Proposed Action is increased TSS. TSS is a non-toxic, non-bio accumulative, conventional pollutant that is naturally present in the receiving environment. TSS affects water quality through increased turbidity, reduced light availability and annual production, and the possible introduction of entrained contaminants.

EPA evaluated the wastewater discharges for the potential to cause unreasonable degradation of the marine environment within its ODCE (See Section 2.1.9.). The ODCE concludes that issuance of an NPDES permit for the LDPI would not result in unreasonable degradation of the marine environment. With the exception of discharges from the STP, all discharges would occur on a contingency basis in the event the disposal well is unavailable. HAK estimates that the average daily TSS concentration would be 250 mg/L and the maximum daily TSS concentration would be 1,000 mg/L (Hilcorp, December 2016 NPDES Permit Application). As discussed previously, ambient TSS concentrations in Stefansson Sound are near 15 mg/L during open-water conditions. The highest concentrations of TSS in the coastal Beaufort Sea occur during spring runoff, when maximum TSS concentrations in the Sagavanirktok River during the spring flood ranges from 244 mg/L to 609 mg/L (Dunton et al., 2009 and Trefry et al., 2009). The TSS concentration in the STP discharge exceeds the measured TSS concentrations in the receiving environment, therefore this would result in a localized effect on water quality. Any discharge of residual chemicals (i.e., sodium hypochlorite, biocides, oxygen scavengers, scale/corrosion inhibitors, etc.) would be required to meet the terms and conditions of the NPDES permit and any impacts are anticipated to be intermittent, short-term, and localized. In summary, EPA's NPDES-permitted discharges under the Proposed Action are anticipated to result in negligible to minor impacts to water quality.

The Proposed Action to build the LDPI would have negligible water quality impacts when compared to ambient TSS concentrations from the Sagavanirktok River that range from 60 mg/L to 106 mg/L during spring break-up (Trefry et al., 2009). The duration for the complete decommissioning of the LDPI is not known and could take several open-water seasons for the island gravel fill to completely erode away.

Overall, adverse water quality impacts from TSS throughout the duration of the Proposed Action are expected to be locally moderate for short periods of time and negligible regionally over the long term.

Localized loss of wetlands and wetland function at the sites of onshore facilities would be a minor effect, due to the small amount of wetland loss being proposed under the Proposed Action.

Small oil spills would affect local water period for short periods of time, and would result in minor effects on water quality. For a more thorough explanation of the fate and behavior of an oil spill, refer to section 4.5.4 Fate and Behavior of an Oil Spill.

Mitigation

Appendix C describes mitigation measures derived from lease stipulations, design features and Best Management Practices (BMPs) the operator committed to, and requirements and BMPs that other agencies typically require. BOEM's conclusion regarding impacts to water quality assumes implementation of, and compliance with, the mitigation measures described in Appendix C, sections C-1 through C-3. No other mitigation measures have been identified.

4.2.2.2. Alternative 2 (No Action)

Under this Alternative, the Proposed Action would not be approved and the actions described in the Liberty DPP would not take place. Impacts to water quality would continue from activities unrelated to the Liberty project.

4.2.2.3. Alternative 3 (Alternate LDPI Locations)

Alternative 3A: Relocate LDPI Approximately One Mile to the East

This alternate location is in deeper water than the Proposed Action and, therefore, the seafloor footprint of the gravel LDPI would be bigger by about 0.6 acres. The volume of gravel necessary to construct the LDPI would increase by 72,000 cy. The offshore pipeline would be approximately 0.5 mi longer. Each of these changes would slightly increase the volume of associated sediments

introduced into adjacent waters. Under Alternative 3A, impacts on water quality would be slightly greater than those under the Proposed Action, but would remain negligible to moderate. While the discharge location would change (see Section 2.2), the overall impacts to water quality as a result of NPDES-permitted discharges under Alternative 3A would be the same as the Proposed Action, which are negligible to minor.

Alternative 3B: Relocate LDPI Approximately 1.5 Miles to the Southwest

This alternate location is in shallower water than the Proposed Action and, therefore, the seafloor footprint of the gravel LDPI would be smaller by about 0.6 acres. The volume of gravel necessary to construct the LDPI would decrease by 72,300 cy. The gravel pit might also decrease in size by 1 acre. The offshore pipeline would be 1.5 mi shorter. Each of these changes would slightly decrease the volume of associated sediments introduced into adjacent waters. Under this Alternative, the impacts on water quality would be slightly less than those under the Proposed Action, but remain negligible to moderate. While the discharge location and permitting jurisdiction would change (See Section 2.2), the overall impacts to water quality as a result of NPDES-permitted discharges under Alternative 3B would be the same as the Proposed Action, which are negligible to minor.

4.2.2.4. Alternative 4 (Alternate Processing Locations)

Alternative 4A: Relocate Oil and Gas Processing to Endicott

The surface area of the LDPI would be reduced from 9.3 acres to 5.4 acres; the seafloor footprint of the LDPI would be reduced from 24 acres to 17.2 acres. The volume of gravel necessary to build the smaller LDPI would be about 387,000 cubic yards less than under Proposed Action. The size of the gravel mine would be reduced by 3 acres. Temporary increases in sediments into adjacent waters associated with gravel mining and construction of the LDPI would be of shorter duration as the time required for construction would be shorter and the volume of associated sediments introduced into adjacent waters would decrease.

Extensive work at Endicott and Endicott SDI would be required to update the existing facilities and install additional equipment. Dust from this work could temporarily increase the TSS of the water in the vicinity.

Additional offshore pipelines would be needed between the LDPI and Endicott. Impacts associated with emplacement of offshore pipeline would increase. TSS would temporality increase along the pipeline route during and for a short time after pipeline emplacement.

Under Alternative 4A, the impact levels associated with gravel mining and construction of the LDPI would be reduced from the Proposed Action but remain negligible to moderate. While the discharge location and permitting jurisdiction would change for certain waste streams (See Section 2.2.5.3), the overall impacts to water quality as a result of NPDES-permitted discharges under Alternative 4A would be the same as the Proposed Action, which are negligible to minor.

Alternative 4B: Relocate Oil and Gas Processing to a New Onshore Facility

Under this Alternative, the working surface area of the LDPI would be reduced from 9.3 acres (Proposed Action) to 6.1 acres. The disturbance to the seafloor would be reduced from 24 acres (Proposed Action) to 18.4 acres. This smaller LDPI would require 15-20 days less time to construct and up to 700,000 cy of gravel to construct, as compared to 927,000 cy for the Proposed Action. As a result, temporary increases in sediments into adjacent waters associated with gravel mining and construction of the LDPI would be of shorter duration.

The route of the subsea pipeline bundle would remain the same as under the Proposed Action.

The additional onshore Liberty Processing Pad would be 4.05 acres of working surface area. The estimated gravel required for construction is 44,800 cy. The impact to onshore water quality during

construction of the pad would be locally and temporarily moderate. The areal extent of the impacts would remain limited.

The footprint of the gravel mine site would decrease, proportionally decreasing impacts to water quality as discussed for the Proposed Action. All other impacts on water quality would remain the same as discussed for the Proposed Action and overall water quality impacts would remain negligible to moderate. While the discharge location and permitting jurisdiction would change for certain waste streams (see Section 2.2.5.3), the overall impacts to water quality as a result of NPDES-permitted discharges under Alternative 4B would be the same as the Proposed Action, which are negligible to minor.

4.2.2.5. Alternative 5 (Alternate Gravel Sources)

Alternative 5A: East Kadleroshilik River Mine Site #2

This alternative gravel mine site is immediately east of the Kadleroshilik River in wetlands vegetation similar to that at the Proposed Action gravel mine site. Impacts from sediments entering the waters adjacent to this site would be similar to those described for the Proposed Action. The loss of wetlands and wetlands function would be similar to that at the Proposed Action gravel mine site.

Overall, onshore water quality impacts would be negligible to minor.

Alternative 5B: East Kadleroshilik River Mine Site #3

This alternative gravel mine site is in wetlands vegetation similar to that at the Proposed Action gravel mine site. Impacts from sediments entering the waters adjacent to this site would be similar to those described for the Proposed Action. The loss of wetlands and wetlands function would be similar to that at the Proposed Action gravel mine site.

Overall, onshore water quality impacts would be negligible to minor.

Alternative 5C: Duck Island Mine Site

This alternative gravel mine site would use and expand the existing Duck Island gravel mine site located in a braided river channel of the Sagavanirktok River. The 32-acre expansion of the existing site is result on the loss of wetlands and wetlands function similar to that at the Proposed Action gravel mine site. Impacts from sediments entering the waters adjacent to this site would be similar to those described for the Proposed Action. When compared to the Alternative Kadleroshilik River mine sites #2 and #3 above, less wetland would be impacted by ice road construction as this site is adjacent to the existing Endicott Road. Overall, onshore water quality impacts would be negligible to minor.

4.2.3. Air Quality

BOEM analyzes impacts of the Proposed Action and Alternatives 2-5 in this section. BOEM considered information and analysis contained within the following documents, which are summarized throughout this air quality assessment:

- 2015 Liberty Development and Production Plan (Hilcorp, 2015)
 - Sec. 9.4 On-proposed LDPI Air Emissions
 - Sec. 13.3.3 Air Quality Mitigation Measures
- 2015 Liberty Environmental Impact Analysis (EIA) (Hilcorp, 2015, Appendix A)
 - Sec. 3.4 Affected Environment: Air Quality
 - Sec. 4.1.4 Environmental Consequences: Air Quality
 - Attachment 1, Air Quality Impact Analysis
 - Appendix B_1, Emissions Inventories and Summaries

- Dispersion Model Report (Hilcorp, 2015, Appendix F)

The criteria and precursor pollutants detailed in Section 3.1.5 can cause harm to human health and the natural environment (40 CFR § 52.21(b)). The action alternatives would elevate concentrations of those pollutants in the ambient air during construction and, to a smaller degree, throughout the life of the Proposed Action. The emissions projected for the Proposed Action and the action alternatives include the following criteria and precursor pollutants:

- Carbon monoxide (CO), a criteria pollutant
- Nitrogen oxides (NO_x), a criteria pollutant and ozone precursor pollutant
- Sulfur dioxide (SO₂), a criteria pollutant
- Particulate matter (fine particles, PM_{2.5} and coarse particles, PM₁₀), criteria pollutants
- Lead (Pb), a criteria pollutant
- Volatile organic compounds (VOC), an ozone precursor pollutant but not a criteria pollutant
- Greenhouse gases (GHG) including: carbon dioxide (CO₂), methane (CH₄), and nitrous oxide (N₂O); not criteria pollutants, but gases that EPA has determined endanger human health and the environment (75 FR 66496, December 15, 2009)

Ozone

Ozone (O₃) is a criteria pollutant but is not directly emitted by any source. Rather, O₃ is formed through a photochemical process that depends on available VOC and NO_x, abundant sunlight, and heat. Because of this photochemical process, there is no practical way to measure or control “tailpipe” emissions of O₃ or, at the Proposed Action level, predict where O₃ would form as a result of emissions of the O₃ precursor pollutants (VOC and NO_x). Therefore, O₃ formation is usually predicted by computer simulation (modeling) on a large regional or even hemispheric scale (Godowitch, Gilliam, and Rao, 2011). However, the EPA finds that project-level emission rates of VOC and NO_x may be used to estimate O₃ formation (40 CFR § 93.158(b) (1) and (2)). The relationship between O₃, NO_x, and VOC is driven by complex nonlinear photochemistry, where some atmospheres are NO_x sensitive, and others VOC sensitive:

- NO_x-sensitive atmospheres (or NO_x-limited) have low concentrations of NO_x and high concentrations of VOC, wherein O₃ increases with increasing NO_x and changes little in response to increasing VOC from new sources.
- VOC-sensitive atmospheres (or VOC-limited) have high concentrations of NO_x and low concentrations of VOC, wherein O₃ increases with increasing VOC and changes little in response to increasing NO_x from new sources; in these types of atmospheres, O₃ can actually increase with decreasing NO_x emissions.

The ambient ratio of new VOC:NO_x emissions appears to directly relate to instantaneous O₃ production. The production rate of O₃ can be loosely estimated based on the emissions of VOC and NO_x (Sillman, 1999; Liang and Jacobson, 1999; Godowitch, Gilliam, and Rao, 2011). The location of such formations, however, would not be predictable. This relationship is discussed in detail in the 2015 Liberty EIA, Sec. 4.1.4.3 Ozone, incorporated here by reference.

The atmospheric conditions necessary for ozone formation (sunlight, ozone precursors, and background emissions of VOC that would produce an NO_x-sensitive atmosphere) are not present over the Beaufort Sea OCS or over the adjacent lands of the Proposed Action Area. Therefore, ozone is not a pollutant of concern for air quality impacts on the eastern ANS due to the Proposed Action or action alternatives.

Lead

Primary sources of airborne lead are ore and metals processing and combustion of fuels containing lead-based additives. None of the fuels used for the project contain lead additives and only trace levels of lead would originate from equipment lubricants containing lead or engine wear. Therefore, lead emissions from the project would be negligible and would not cause or contribute to a violation of the lead National Atmospheric Air Quality Standards (NAAQS).

Air Quality Regulatory Program (AQRP)

Under the Proposed Action, Hilcorp would proceed with the development and production activities described in their proposed Liberty DPP. The Liberty DPP entails operation of the proposed LDPI, which would be located on the Federal OCS and qualify as a “facility” under the jurisdiction of BOEM’s Air Quality Regulatory Program (AQRP). BOEM regulates emissions from such facilities for compliance with the NAAQS (established by EPA pursuant to the Clean Air Act (42 U.S.C. 7401 et seq.)), to the extent that those emissions significantly affect the air quality of any State. BOEM regulations at 30 C.F.R. § § 550 Subpart C set forth the process for determining whether air pollutant emissions from such facilities must be controlled. The first step in BOEM’s AQRP analysis of a proposed facility is to determine whether the facility is exempt from further review. This determination is based on a calculation that accounts for anticipated emissions as well as the distance of the proposed facility from shore. Here, BOEM has determined that the LDPI is not exempt from further review under the AQRP. The next step in BOEM’s AQRP analysis of a proposed facility is to determine whether the facility’s anticipated emissions of SO₂, PM/TSP, NO₂, CO, or VOC would result in an onshore ambient air concentration above a specified significance level. Here, BOEM reviewed modeling of the ambient air concentrations that would occur from emissions sources on the LDPI. The results of this modeling indicate that the applicable significance level would not be exceeded for any of these air pollutants. As such, BOEM’s AQRP does not require the control of emissions from the LDPI facility.

Emissions Sources

This analysis of potential impacts to air quality assumes the operation of all proposed emissions sources as described in the DPP, without further regulatory controls. BOEM’s NEPA analysis accounts for emissions from sources associated with the proposed LDPI facility as well as from all other emissions sources described in the DPP, regardless of whether those sources are included within a facility that is subject to regulation and control under BOEM’s AQRP. Relevant air emissions sources are (1) mobile sources associated with proposed LDPI and offshore pipeline construction activities, (2) mobile sources associated with onshore facilities and pipeline construction activities, (3) stationary sources associated with drilling operations, (4) stationary sources associated with production operations, (5) propulsion and auxiliary engines operated onboard vessels, (6) helicopters and light aircraft, and (7) mobile and stationary sources associated with accidental oil spills and gas releases.

Diesel-powered engines would be the main source of emissions during construction. Most diesel engines would operate on the proposed LDPI, with near complete conversion to natural gas engines as the production wells came on-line. Equipment and vessels used during onshore and offshore pipeline construction would produce substantial emissions and are considered here. Diesel fueled engines emit mostly NO_x, CO, and particulate matter. Behavior of the pollutants would vary depending on whether the source is stationary or mobile, location of the source, duration and timing of the source throughout the Proposed Action. Stationary sources usually create steady emissions from a fixed location, whereas mobile sources produce emissions relative to the thrust and power rating of individual sources (e.g., vehicle, boat, aircraft) dispersed by source movement in addition to atmospheric mixing over distance caused by winds and turbulence. Moving sources result in emissions discharged over some distance, with elongated plumes of pollutants expanding horizontally

and vertically, diffusing as they mix with the surrounding air. The effects of dispersion and diffusion decrease the ground-based impact of all emissions as distance from the source increases.

Helicopters and other aircraft create emissions at varying elevations with respect to the ground. Due to dispersion, emissions from aircraft cruising at altitudes higher than 1,500 ft (457 meters (m)) above the surface would not influence concentrations measured at the surface (Kadygrov et al., 1999). Therefore, only emissions that occur during landing and takeoff operations are considered here. All types of offshore and onshore stationary sources associated with oil and gas operations emit pollutants each day for as long as the operation continues. Pollutants from stationary sources tend to affect the same downwind areas continuously, and thus could deteriorate air quality at downwind locations more than mobile sources.

Dispersion Analysis of Project Emissions

The latest version of AERMOD-COARE and AERMET were used to model and assess project impacts on ambient levels of nitrogen dioxide (NO₂), CO, PM₁₀, PM_{2.5} and SO₂ from project-related activities during the open-water period (July through October) and during periods when the project surface area is covered with snow and ice (November through June), respectively. AERMOD is a steady-state, Gaussian dispersion model developed by the American Meteorological Society (AMS) and EPA and is the recommended dispersion model for characterizing transport of emissions over land at distances less than or equal to 50 kilometers (km) (31 miles (mi)) from the source under 40 CFR 51, Appendix W.

Figure 4.2.3-1 shows the modeling domain and near field receptors (blue dots) centered over the proposed LDPI, Endicott SDI and gravel mine location. This grid will characterize and locate the maximum pollutant impacts on the SOA from the planned construction, development and production activities. In this Section (4.2.3) and its subsections the Proposed Action Area is defined as the modeling grid shown in Figure 4.2.3-1. The ambient air quality boundary of the OCS facility located 500 m (546 yards) from the edges of the LDPI, which is consistent with USCG regulations 33 CFR Part 147 that establish a 500 m (546 yd) safety zone around oil and gas production facilities on the OCS.

Background concentrations stem from local natural processes, anthropogenic (human made) sources, and pollutants transported into the area from other sources. This differs from the existing emissions described in Section 3.1.5.3 and Table 3.1.5-1 which describe the annual gross tonnage of pollutants emitted into the atmosphere throughout the course of the year. Background concentrations are derived from the evaluation of data sampled and analyzed using air monitoring devices, and estimate the likely magnitude, spatial, and temporal variability of pollutants across an area (McKendry, 2006). Monitoring data may be obtained from EPA-, state-, or industry-owned devices that use EPA-approved equipment and methods. Table 4.2.3-1 summarizes background concentrations used in these analyses. Appendix B-2 provides more information on background concentrations.

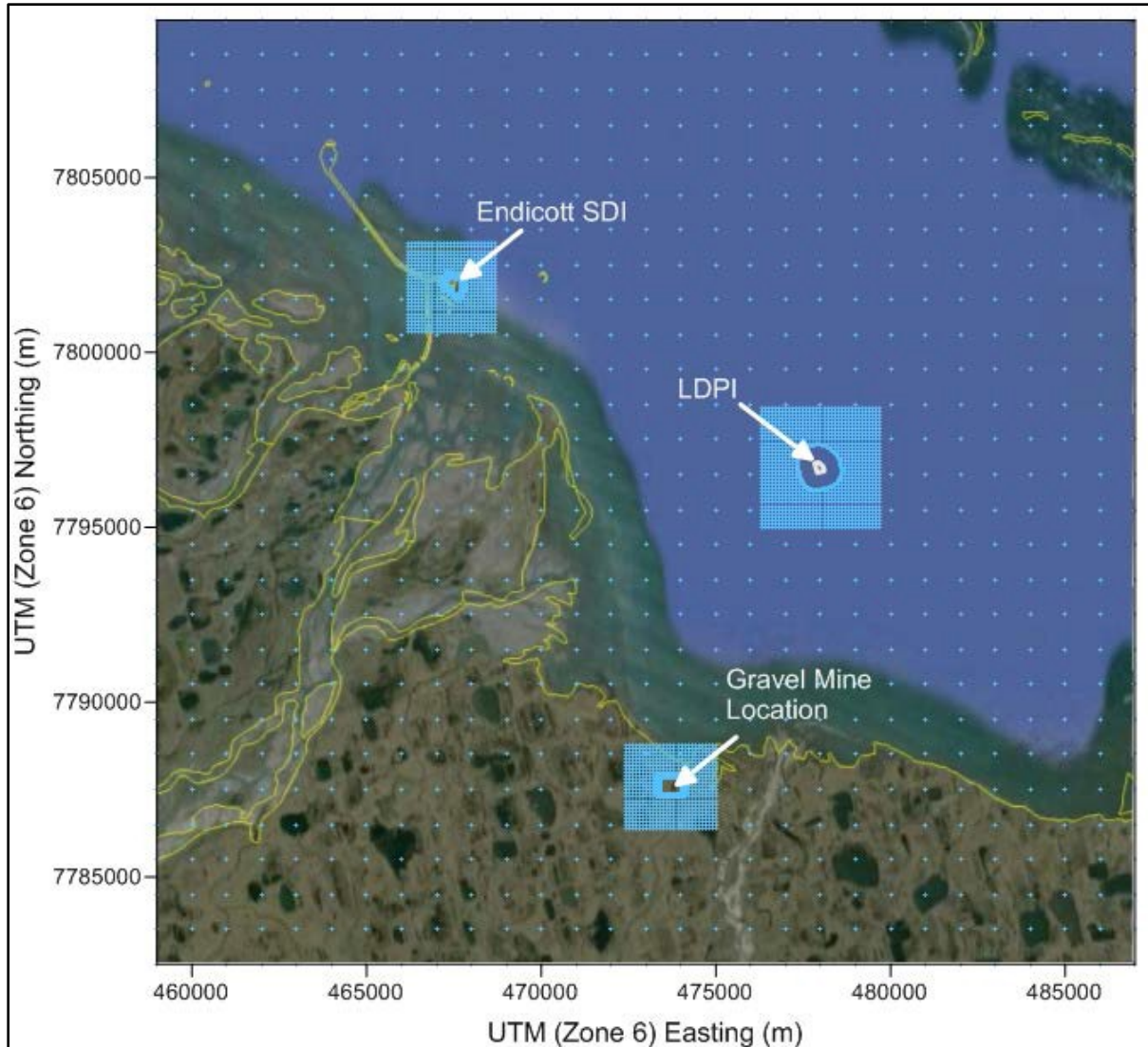

Figure 4.2.3-1. Proposed Action Modeled Receptors. Source: 2015 Liberty EIA, Attachment 1, Figure 3-2.

Emissions Impact Analysis

Computer simulation of air dispersion is the second step in discerning the potential impact of new emissions. This analysis uses the most conservative case, wherein every emitter (generator, drill rig, vehicle vessel, and etc.) is assumed to run at full capacity for 24 hours of each day that particular piece of equipment is used. The analysis is based on the maximum annual emissions projected to occur during the following stages outlined in the 2015 Liberty DPP and summarized in Chapter 2 (Table 2-1):

- LDPI Construction (Year 2)
- Flowline Construction (Year 3)
- Facilities Installation (Years 2-4)
- Drilling and Development (years 3-5)
- Production Operations (Year 3 – decommissioning)

The projected emissions, not including GHGs and VOCs, are translated into pollutant concentrations using the computer simulated dispersion models described above. Since the primary NAAQS are

designed to protect human health, BOEM analyzes the impacts of Proposed Action and action alternative emissions on the primary NAAQS (summarized in Table 4.2.3-1). Also, as mentioned in Section 3.1.5, the North Slope Borough is a Class II area and as such BOEM will draw comparisons of the projected increase to the Maximum Allowable Increase (MAI) for a Class II area (Table 4.2.3-1). The MAI applied in the analysis acts as a conservative estimate of the maximum PSD increment consumption that could occur if the project was constructed and actually emitted at the projected emission rates. A true increment analysis would require an account of both creditable emission increases and decreases for each triggered pollutant after the baseline date. Exceedance of the MAI by the Proposed Action does not necessarily mean the project would violate the PSD increment or would result in a significant impact to air quality. This analysis does not constitute as a PSD increment analysis (which is not required) but is presented as an additional impact determinate. A PSD increment consumption analysis is required for permitting of new major sources or major modifications of existing sources where ADEC and/or EPA have jurisdiction. Since the Proposed Action is under BOEM jurisdiction and would not be a major source, PSD increment consumption analysis will not be required under ADEC's air permitting program (baseline dates and PSD increments promulgated in 18 AAC 50.020). Additional information on MAI/PSD increments is available in Appendix B-6.

The potential for adverse air quality effects is assessed by combining the concentrations of the modeled emissions together with the existing concentrations of background pollution, collectively the “design concentration.” The modeled emissions used in this comparison are the maximum modeled concentration at any receptor over state lands within the modeling domain. The design concentrations are then divided by their respective NAAQS to determine what percentage of the NAAQS the resulting concentration may lead to. As another impact determinate, the concentration of projected emissions for available MAI listed pollutants will also be shown, defining what percentage of the MAIs the project would be within. In both cases, if the resulting concentration reaches 100% it would mean that the pollutant has the likelihood of exceeding the NAAQS and/or the MAI. For the following NAAQS comparisons “Year 1” impact percentages are from the background concentrations alone. Only meaningful impacts, where the resulting impact is greater than 25% of the NAAQS, will be displayed. Other air quality impact criteria describing the: intensity, duration, potential and geographic extent are also used to frame the conclusions. More detailed NAAQS impact tables and impact criteria definitions can be found in Appendix B.

Table 4.2.3-1. Background, NAAQS and MAI concentrations of Criteria Air Pollutants

Pollutant	Averaging Period	Background	NAAQS ¹	MAI ²
NO ₂	1-Hour ³	81 µg/m ³	188 µg/m ³	NA ⁴
NO ₂	Annual	1 µg/m ³	100 µg/m ³	25 µg/m ³
CO	1-Hour ⁵	1,742 µg/m ³	40,000 µg/m ³	NA ⁴
CO	8-Hour ⁵	1,094 µg/m ³	10,000 µg/m ³	NA ⁴
SO ₂	1-Hour ⁵	13 µg/m ³	196 µg/m ³	NA ⁴
SO ₂	3-Hour ⁵	11 µg/m ³	1,300 µg/m ³	512 µg/m ³
SO ₂	24-Hour ⁵	4 µg/m ³	365 µg/m ³	91 µg/m ³
SO ₂	Annual	2 µg/m ³	80 µg/m ³	20 µg/m ³
PM ₁₀	24-Hour ⁷	53 µg/m ³	150 µg/m ³	30 µg/m ³
PM ₁₀	Annual ⁸	NA ⁹	NA ⁹	17 µg/m ³
PM _{2.5}	24-Hour ¹⁰	6 µg/m ³	35 µg/m ³	9 µg/m ³
PM _{2.5}	Annual ⁸	3 µg/m ³	15 µg/m ³	4 µg/m ³

Notes: ¹National Primary and Secondary Ambient Air Quality Standards, 40 CFR Part 50,

²Maximum Allowable Increase based on PSD Class II Increment Levels.

³The standard is based on the 3-year average of the 98th-percentile of the annual distribution of 1-hour daily maximum NO₂ concentrations.

⁴NA = Not Applicable. No MAI (Class II PSD Increment Limit) for the designated pollutant averaging period exists.

⁵Not to be exceeded more than once per year.

⁶The form of this standard is the 3-year average of the 99th percentile of the annual distribution of 1-hour daily maximum SO₂ concentrations.

⁷Not to be exceeded more than once per year on average over three years.

⁸Annual arithmetic mean, averaged over three years.

⁹NA = Not Applicable. No annual PM₁₀ NAAQS exists.

¹⁰The form of this standard is the 3-year average of the 98th percentile of annual 24-hour average concentrations.

4.2.3.1. The Proposed Action

Under this alternative (summarized in Section 2.2) BOEM would approve Hilcorp’s proposed development and production plan for the Liberty prospect. The construction activities and production operations associated with the Proposed Action would generate the criteria and precursor pollutants listed in Section 4.2.3. The types and amounts of air pollutants generated would vary based on the phases of the project. Tables with the types and amounts of air pollutants generated by phase and alternatives are available in Appendix B, Section B-3.

The first three phases modeled are the projected emissions due to major construction activities that would occur over the first four years of the Proposed Action. Phase 1 includes the construction activities in the first and second years, specifically ice road construction; gravel mining activities including blasting, gravel processing and gravel hauling; and the installation of protective sheet piles, concrete slope armor and vertical support members for module foundations. Phase 2 includes the construction activities in year 3 including the installation of the single-phase subsea pipeline between the LDPI, transitioning onshore to tie into the Badami pipeline. Phase 3 includes year 4 construction activities, such as the transport and installation of prefabricated facility modules and the mobilization of drill rig and support equipment to the proposed LDPI. Phase 4 modeled is the projected emissions from the initial drilling and development (years 3-5) and production operations that would continue throughout the lifetime of the Proposed Action, to include annual ice road construction and maintenance throughout the life of the project.

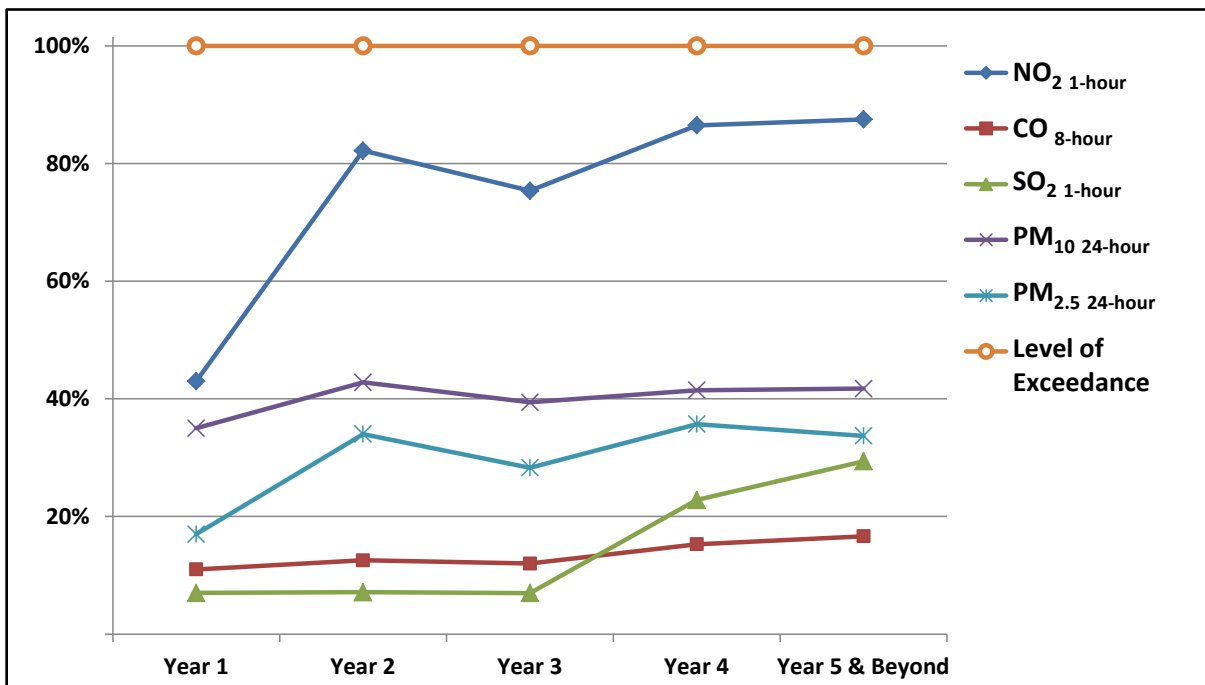

Figure 4.2.3-2. Proposed Action NAAQS Comparison.

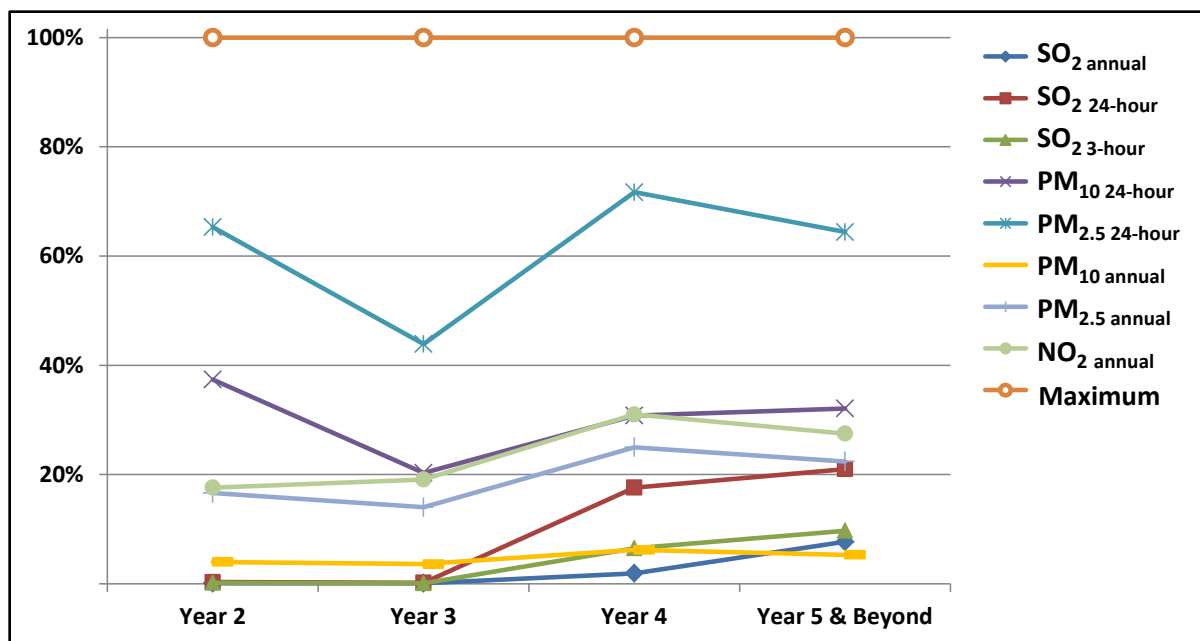

Figure 4.2.3-3. Proposed Action Class II MAI Comparison.

The Proposed Action would not result in any criteria pollutant exceeding the NAAQS during any stage or phase of development and production at the shoreline as shown in Figure 4.2.3-2. The highest potential pollutant impact relative to its respective NAAQS is 1-hour NO₂, which is based on the 98th percentile of the annual maximum daily 1-hour NO₂ concentration, (also called the 1-hour NO₂ design concentration). Figure 4.2.3-3 shows that for the Proposed Action the increase due to the project would not exceed any MAI for a Class II area during the lifetime of the project. Also, considering that the closest permanent community is over 60 miles west of the Proposed Action Area (as mentioned in Section 3.3.3.2) any emissions produced as a result of the Proposed Action would be dispersed and well mixed with the ambient air to at or below normal background concentrations before reaching those communities. Subsequently, the Proposed Action would not result in any degradation to the human health conditions of those communities.

Small Oil Spills (<1,000 barrels)

Evaporation of small accidental refined oil spills would result in temporary localized increases in VOC. The volatile components of the fuel would evaporate within the first 24 hours for a spill 3 barrels (bbl) or less and would take 3 days for a spill of 200 bbl, potentially causing localized air quality degradation in the immediate vicinity of the spill. Ambient hydrocarbon concentrations in the air would be higher than those of a crude oil spill of similar size but would persist for a shorter time. Small spills of crude oil would persist longer in the environment and result in greater air quality impacts than spills of refined products. The impacts at a given location would depend on the time of year, size, location, and duration of the spill and meteorological conditions such as wind speed and direction. The possible impact from increased emissions of VOC from any oil spill is the formation of ozone. However, the volume of VOC emissions resulting from such small spills, when considering the levels of NO_x emissions likely already emitted during development and production is not expected to be sufficient to create conditions favorable for the formation of ozone. For these kinds of small spills, the level of evaporative emissions would not likely impact onshore air quality. Cleanup and response activities also would have a minor impact by increasing emissions.

Large Oil Spills (≥1,000 barrels)

The analysis of a large oil spill in Section 4.1.1.1 and Table 4.1.1-3, assumes that a large spill would originate from the proposed LDPI, or the proposed offshore or onshore pipeline. Oil spills may be comprised of either diesel oils or crude oils. Based on the large oil spill described in Table 4.1.1-3, this analysis of evaporative emissions presumes that a large spill from the proposed LDPI could potentially be comprised of either crude oil or diesel fuel, where either would be in the amount of 5,100 bbl, whereas a large spill from an onshore pipeline rupture would be comprised of crude oil in the amount of 2,500 bbl and an offshore pipeline would be comprised of 5,000 bbls in a crude oil rupture or 1,700 bbl in a crude oil leak. Such a spill would result in increased emissions of VOC over an area larger than from a small spill, and evaporation would continue for a longer period of time until the mass of oil is evaporated or removed from the water surface.

A large oil spill on the Beaufort Sea OCS, if released from the proposed LDPI where oil and gas activities are anticipated as described in the Proposed Action, could occur about 6 statute miles from shore. Or, the release could be from a pipeline, anywhere between the Badami tie-in point and the proposed LDPI. Assuming no oil would freeze into the sea ice, the distance combined with the wind conditions over the Beaufort Sea, would likely disperse the VOC. The gases could be picked up by upper-level winds and transported away from the Arctic. However, this would depend on how far and how fast the oil slick spreads. Assuming a large oil spill occurs within the Beaufort Sea OCS, the greatest amount of VOC that could potentially evaporate from the kind of large oil spill described in Appendix A would be 249.2 and 462.7 short tons during the summer and meltout spills, respectively.

Summer Spills

The Arctic experiences more frequent summertime precipitation, which removes some atmospheric pollutants. Arctic summer weather is driven by two semi-permanent pressure systems, the Icelandic low over Greenland and the Pacific high in the Gulf of Alaska (Ahrens, 2013). The interaction of these systems causes northeast winds over the Arctic in summer; breezes can be moderate, up to 3 to 8 m/s (6.7-17.8 miles per hour (mph)), with higher winds during storms (BOEM, 2013). There could be four to six storms a month over the Arctic increasing the precipitation over sea and land (NSIDC, 2000).

The windy, rising air and precipitation destabilize the lower atmosphere, allowing the dispersion of pollutants. Gaseous pollutants rise with the surrounding air and are caught up in higher steering winds that allow maximum diffusion of pollutants. Summertime impacts from a large oil spill would occur if northeast winds drove pollutants over Alaska's northern coastline and the tundra of the North Slope. Impacts would be less likely if northwest winds directed pollutants parallel to the coastline on the west side of the North Slope or transported pollutants out to sea.

While the opportunity for ozone formation exists, given the short-term existence of a relatively low amount of VOC evaporated into the lower atmosphere from a large oil spill, the impact to air quality, as determined relative to Section 4.1.2 Impacts Scale, would likely be negligible to minor both offshore and onshore, and although short-lived, could occur over a large area.

Winter Spills

Arctic winter Weather is dominated by the Beaufort high pressure system and the semi-permanent Aleutian low, which occurs over the Bering Sea (Ahrens, 2013). Northern hemisphere high pressure systems tend to rotate clockwise, while heavy cold air tends to flow down and away from such pressure centers, creating stable, cold dry conditions. Conversely, low pressure system air tends to lift warmer air which becomes buoyant; air rises counterclockwise toward the center of lower pressure system causing precipitation and unstable conditions. The interaction of these two systems results in light to moderate (2-8 m/s (5-18 mph)) east to northeast winds with some strong breezes (12-m/s (25 mph)) from the east during storms. Higher winds tend to peak during October through December

when there is little to slow down the wind over open water (Veltkamp and Wilcox, 2007). While the wind does not affect evaporation rate of VOCs from spilled oil, it does increase dispersion of VOCs once evaporated into the lower atmosphere.

Formation of ozone, which is used to measure the adverse impacts of increased VOC emissions, is unlikely to occur in the winter over the Arctic due to the months without sunlight, which is a necessary ozone formation component. Therefore, impact to air quality would likely be negligible to minor both offshore and onshore, and although short-lived, could occur over a large area.

Spill Response

Three oil spill response activities may impact air quality: in-situ burning, mechanical recovery, and the use of dispersants.

In-situ Burning

In-situ burning as part of a cleanup of spilled crude oil or diesel fuel would increase emissions of NO_x, SO₂, and CO, but would decrease VOC emissions as compared to evaporation. Fingas et al. (1995) describes an oil-spill test burn at sea monitoring program. The authors took extensive ambient measurements during two burns in which approximately 300 barrels of crude oil were burned *in-situ*. During the burn, NO_x, SO₂, and CO concentrations were measured only at background levels and frequently were below detection limits. For small spills, because of the small volume of oil and the quick methods of cleanup that are available, the level of effect on air quality likely would be negligible.

Cleanup of a large oil spill would likely result in detectable impacts to air quality conditions when considering the emissions from the oil, by either evaporation or burning, combined with all the emissions from vessels, equipment, and personnel needed to remove the oils. Thus, the methods and consequences of the process, and methods used to remove oil from a large spill, may actually outweigh the air effects of the oil itself. From this perspective, a large oil spill would be likely to have a minor effect both offshore and onshore, and although short-lived, could occur over a large area.

Mechanical Recovery

Mechanical recovery physically removes oil from the ocean and is accomplished with devices such as containment booms and skimmers. A containment boom is a rope-like device that floats and is deployed in the water and positioned to contain and concentrate spilled oil into a pool thick enough to permit collection by a skimmer. The skimmer collects the oil and transfers it to a storage vessel (storage barges or oil tankers) where it would eventually be transferred to shore for appropriate recycling or disposal. As mentioned in Section 4.2.3 Emissions Sources, most mobile emissions including those of vessels participating in recovery operations have a negligible impact to the air quality of any specific ground-based location. The dispersion of emissions from a moving source makes the accumulation of pollutants less of a concern at any specific downwind location.

Dispersants

Chemical dispersants may be applied by marine vessels or aircraft, are liquid, powder, or aerosol surfactants, solvents, and other compounds, that break up the oil slick by decreasing interfacial tension between water and oil. The result is small oil droplets that will not merge with other oil droplets. The droplets stay suspended in the water column and are transported by waves. The objective of using a dispersant is to transfer oil from the sea surface into the water column (Ocean Studies Board, 2005). While the use of dispersants can decrease the size of the oil slick, toxic emissions from the chemicals and solvents used are possible. Following the DWH event, the EPA mobilized Trace Atmospheric Gas Analyzer (TAGA) buses (self-contained mobile laboratories that conduct air quality monitoring) (EPA, 2015). The EPA conducted monitoring for two chemicals in dispersants that have the greatest potential for air quality impacts: EGBE (2-Butoxyethanol) and

dipropylene glycol monobutyl ether. The post DWH TAGA analysis detected levels of these chemicals in the air along the Gulf Coast that were below the threshold that would likely result in health effects. Consequently, EPA suggests that using dispersants for oil-spill cleanup would cause a negligible impact on air quality (EPA, 2015).

Impact Conclusions

Routine activities under the Proposed Action that are expected to have a measurable impact on air quality are: air emissions from vessel traffic, drill rigs, construction activities, production operations and other offshore and onshore infrastructures developed for the purpose of supporting offshore oil and gas operations. The emissions of these criteria pollutants from the Proposed Action would increase concentrations to some extent in various locations within the region.

Due to the characteristics of pollutant transport by the wind and movement of sources, emissions from vessels, helicopters, and onshore vehicles associated with the Proposed Action would have a negligible impact to the air quality of any specific ground-based location. The dispersion of emissions from a mobile source makes the accumulation of pollutants less of a concern at any specific downwind location with a decrease in pollutant accumulation with increasing distance from the source.

Large spills are likely to have minor levels of effect on air quality. Air quality impacts immediately following a large spill would be short-term. Oil spill response practices are described in Section 4.6. GIUE (oil spill drills) are not expected to alter impact conclusions for air quality for routine activities or accidental spills because they are infrequent, of short duration (<8 hours), and utilize existing equipment. The potential effects of oil spill response activities on air quality include a negligible impact from mechanical recovery operations, use of dispersants and in situ burning of small spills, and a minor impact from in situ burning of large spills.

Routine activities, which include small spills, under the Proposed Action would have a measureable impact on Air Quality. The impacts would have low to medium intensity due to one of the modeled pollutants being estimated at >50% but <100% of the NAAQS. The impacts would be temporary and interim, over the 25-year lifetime of the Proposed Action. Construction emissions and their resulting impacts would be limited to the first 3-5 years of the project. Once the process of drilling has been largely completed (2nd Qtr. Execute Year 5) and the operation shifts toward production, emissions associated with the operation and support of the rig(s) would decrease considerably, reducing the overall impact of operations.

Impacts resulting from the Proposed Action would be localized within the Proposed Action Area as captured by the modeling domain (Figure 4.2.3-1), with the highest level of impacts at the shoreline area closest to the LDPI and lessening moving inland. Due to the lessening level of impact moving inland, BOEM concludes that there would be no air quality impacts to the community of Nuiqsut, which is over 60 miles west of the proposed action area. Except where noted otherwise, this conclusion applies to all action alternatives. The air quality in the areas surrounding the project would recover and return to pre-project levels shortly after the completion of the project. Due to these impact criteria the overall impact on Air Quality from the Proposed Action are expected to be minor.

4.2.3.2. Alternative 2 – No Action

Under this alternative, the Proposed Action would not be approved and no new direct or indirect emissions would occur. As such, this alternative would have no new impacts to air quality and not result in any degraded human health conditions.

4.2.3.3. Alternative 3 – Alternate Location for proposed LDPI

Under this alternative, the proposed LDPI would be relocated to one of two locations. Alternative 3A would relocate the LDPI one mile to the east, keeping the proposed LDPI in Federal waters.

Alternative 3B would relocate the LDPI 1.5 miles southwest, placing the proposed LDPI into SOA waters, changing the air quality jurisdiction. Emissions from the LDPI facilities would be regulated and potentially controlled by ADEC. There are differences in vehicle and vessel trip distances between these two sub-alternatives, and the Proposed Action; however, the modeling used a conservative approach, running engines at full capacity for 24 hours/day. BOEM anticipates that emissions from vehicles and vessels under these two sub-alternatives are sufficiently captured in models for the Proposed Action, despite slight differences in trip distances.

Alternative 3A: Relocate LDPI Approximately One Mile to the East

The plan changes outlined in Section 2.2.4 would impact Phases 1, 2 and 4 of the Air Quality impact scenarios (timelines for phases are described in section 4.2.3.1). Under this alternative, changes to the LDPI and the drilling unit would require the Hilcorp to submit a revised modeling analysis including any application of operational controls and/or BACT to demonstrate that the stationary sources and associated activities would not result or contribute to a violation of any ambient air quality standards or air quality increment standards. Variations in emissions from the Proposed Action changes are summarized below and illustrated in Figures 4.2.3-4 and 4.2.3-5.

Phase 1: Ten additional days of construction time would lead to a 6.67% increase in emissions.

Phase 2: An 8% increase in time and materials would lead to an 8% increase in emissions.

Phase 3: There is no change in potential emissions from the Proposed Action.

Phase 4: Thirty-five days of additional construction time would lead to a 9.72% increase in construction emissions and the larger Drill Unit (up from 2,100 hp to 3,000 hp) would lead to a 39% increase in emissions.

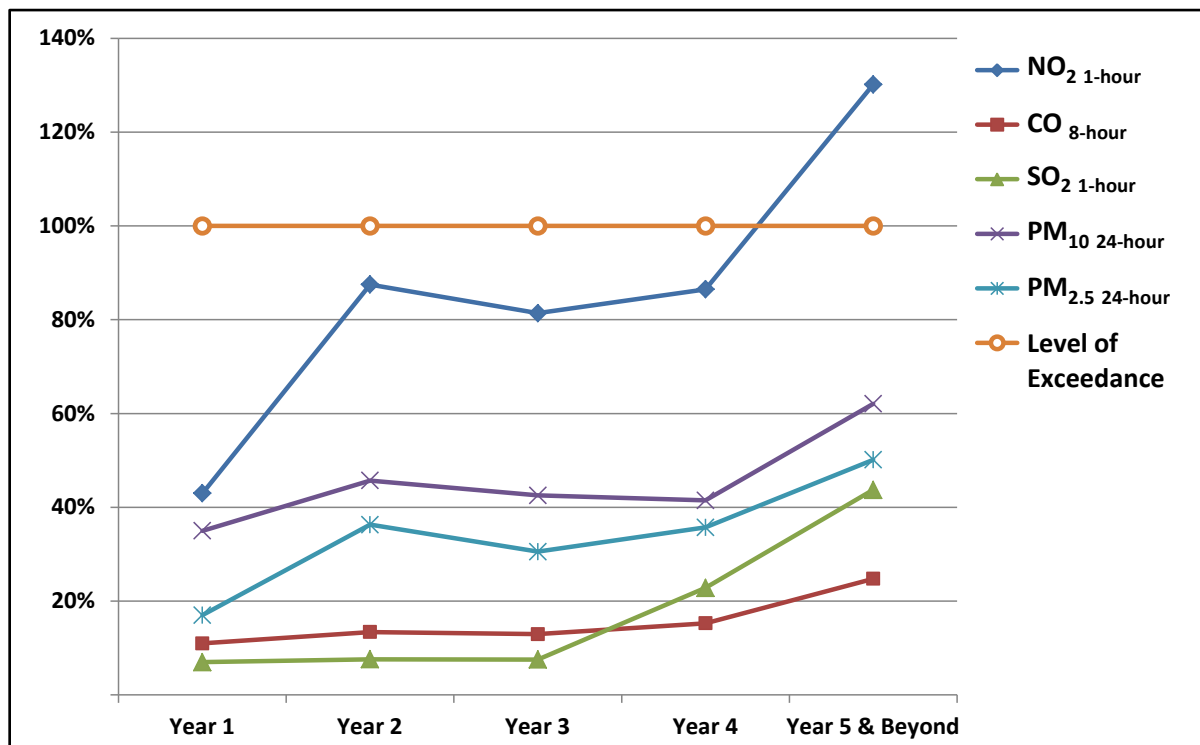

Figure 4.2.3-4. Alternative 3A NAAQS Comparison.

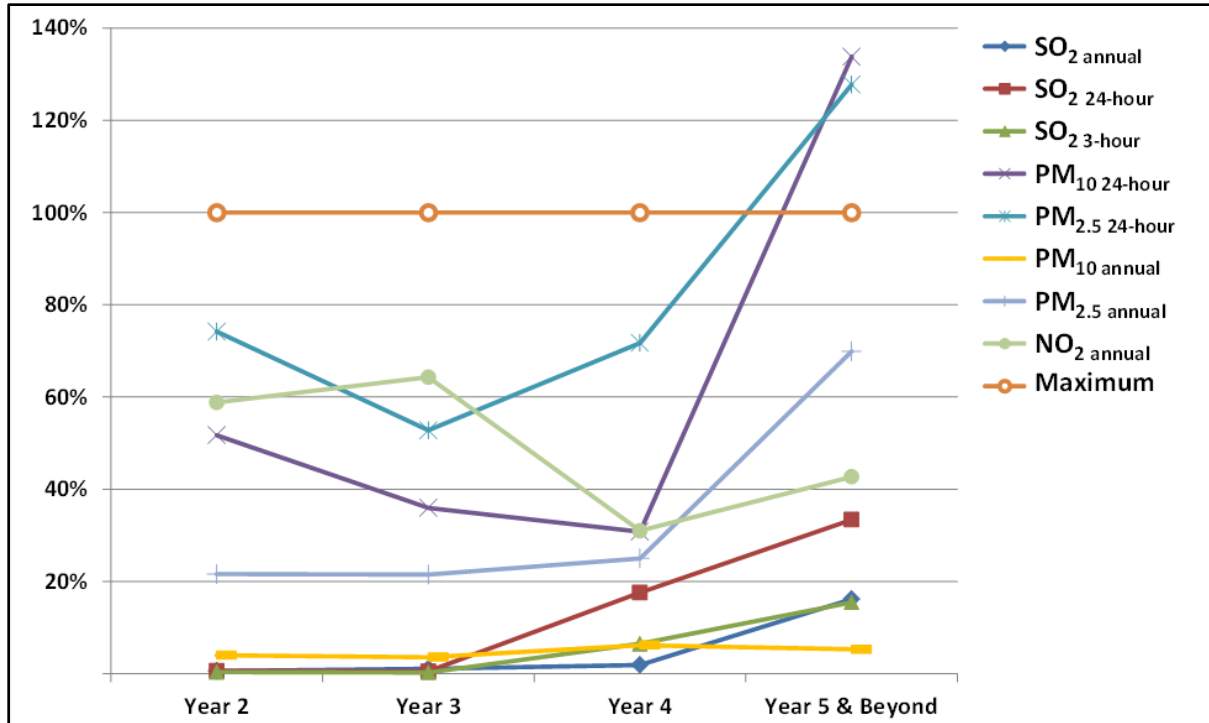

Figure 4.2.3-5. Alternative 3B Class II MAI Comparison.

Conclusion for Alternative 3A

Figures 4.2.3-4 and 4.2.3-5 show that emissions from Phases 1-3 (years 2-4) would not differ substantially from those described for the Proposed Action (Alternative 1). However Phase 4 (year 5) for this alternative, which describes production operations from year 5 through the lifetime of the project, would have the likelihood of violating the 1-hour standard NAAQS for NO₂ and exceeding the Class II MAI for both PM_{2.5} 24-hour and PM₁₀ 24-hour.

Impacts of Alternative 3A on air quality would be higher than those for the Proposed Action, the routine activities under Alternative 3A would have a larger measurable impact on Air Quality at the shore. The impacts would have medium to high intensity due to NO₂ 1-hour being estimated at or greater than 100% of the NAAQS. The impacts would be temporary and interim, over the 25-year lifetime of the Proposed Action. Construction emissions and their resulting impacts would be limited to the first 3-5 years of the project. Once the process of drilling has been largely completed (2nd Qtr. Execute Year 5) and the operation shifts toward production, emissions associated with the operation and support of the rig(s) would decrease considerably, reducing the overall impact of operations. Impacts resulting from the Proposed Action would be localized within the Proposed Action Area as captured by the modeling domain (Figure 4.2.3-1), with the highest level of impacts at the shoreline area closest to the LDPI and lessening moving inland. The air quality in the areas surrounding the project would recover and return to pre-project levels shortly after the completion of the project. Due to these impact criteria the overall impacts on Air Quality from Alternative 3A are expected to be moderate for routine activities, negligible for small spills, and minor for a large spill.

Alternative 3B: Relocate LDPI Approximately 1.5 Miles to the Southwest

The plan changes outlined in Section 2.2.4 would impact Phases 1, 2 and 4 of the Air Quality impact scenarios. The impacts from this alternative are two-fold. There would be emissions variations from the Proposed Action due to increases and decreases in construction. Also, due to the change in proposed LDPI location, there would be a 1.5 mile decrease in distance the pollutants have to disperse before impacting the shoreline. BOEM estimates that reducing the distance that pollutants have to

disperse by 1.5 miles may result in an increase of up to 58% in pollutant concentrations at the shoreline. These estimates were created using Gaussian dispersion tables with similar input values from the modeling data as a control, using mock emissions values ranging from 5-150 tons per year, and using the proposed distances from shore. More information on the pollutant concentration increase due to dispersion calculations is available in Appendix B-5 and tables of each effected phase and the respective variations in emissions from the plan changes and increases due to the lack of dispersion are available in Appendix B-3.3 (Tables B-3.3-1 through B-3.3-3):

Phase 1: Six fewer days of construction time would lead to a 4% reduction in construction emissions. However, the 1.5 mile reduction in dispersion distance may lead up to a 58% increase in Project emission concentrations during Phase 1.

Phase 2: A 20% reduction in time and materials would lead to a 20% decrease in emissions. However, the 1.5 mile reduction in dispersion distance may lead up to a 58% increase in Project emission concentrations during Phase 2.

Phase 3: There is no change in potential emissions from the Proposed Action.

Phase 4: Seventy-five days of additional construction time would lead to a 20.83% increase in construction emissions and the larger Drill Unit (up from 2,100hp to 5,000hp) would increase emissions of 216%.

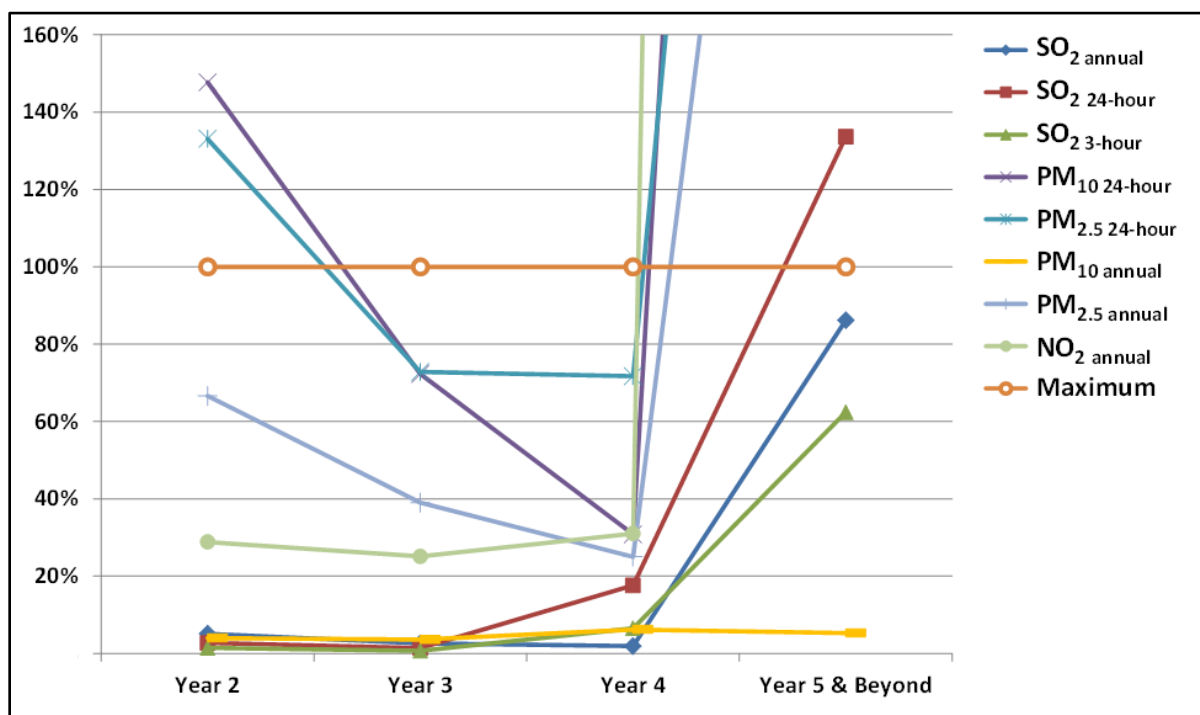

Figure 4.2.3-6. Alternative 3B NAAQS Comparison.

Conclusion for Alternative 3B

Figures 4.2.3-6 and 4.2.3-7 show a large increase in emissions from Phases 1, 2 and 4 as compared to the proposed action. These figures also show that Phase 4 for this alternative, which describes production operations from year 5 though the lifetime of the project, not only demonstrates the potential to exceed the NAAQS for PM_{2.5}, PM₁₀ and the 1-hour standard for NO₂ but the gross exceedance of the Class II MAI for SO₂, PM_{2.5}, PM₁₀ and NO₂. The Air Quality impacts of this alternative are expected to lead to effects on human health for those populations in or near the surrounding Proposed Action Area at this level of analysis. And as mentioned above this alternative

would change the jurisdiction of Air Quality such that ADEC would be the permitting authority for this location and the applicant would need to submit an updated modeling analysis including the application of operational controls and/or BACT to demonstrate that the stationary sources and associated activities would not result or contribute to a violation of any ambient air quality standards or air quality increment standards.

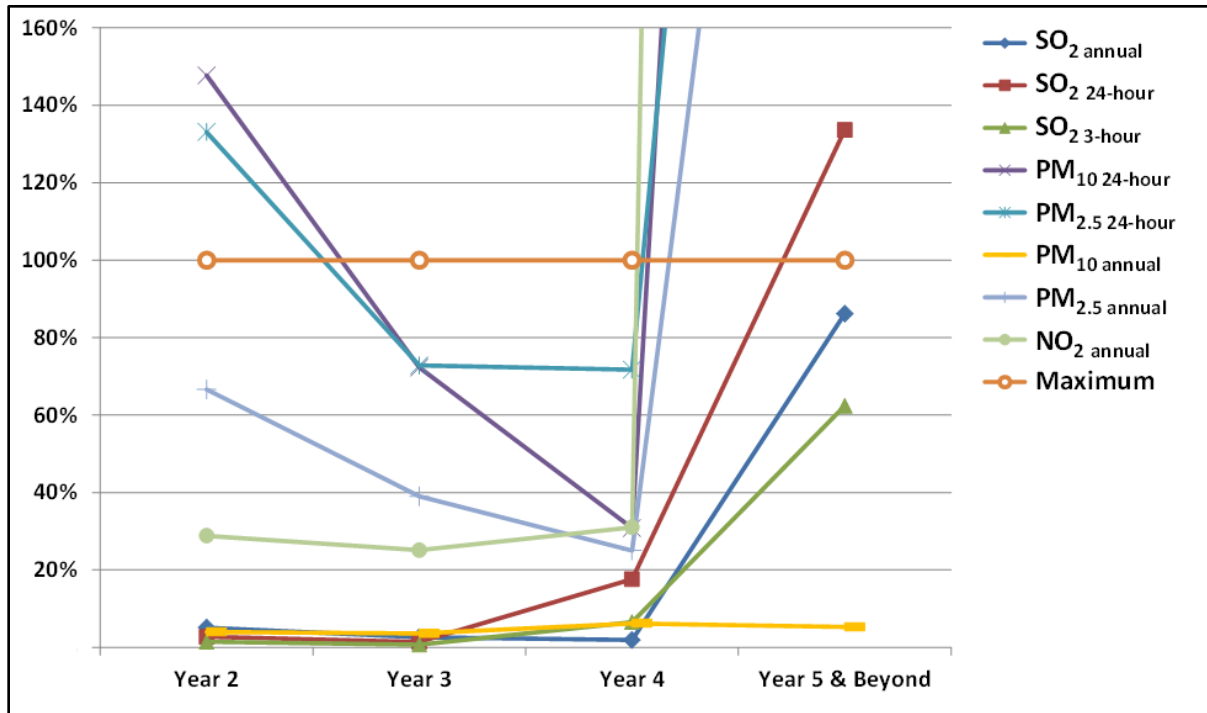

Figure 4.2.3-7. Alternative 3B Class II MAI Comparison.

Impacts of Alternative 3B on air quality would be higher than those for the Proposed Action, the routine activities under Alternative 3B would have a larger measureable impact on Air Quality. The impacts would have high intensity due to the modeled pollutants being estimated at or greater than 100% of the NAAQS. The impacts would be temporary and interim, over the 25-year lifetime of the Proposed Action. Construction emissions and their resulting impacts would be limited to the first 3-5 years of the project. Once the process of drilling has been largely completed (2nd Qtr. Execute Year 5) and the operation shifts toward production, emissions associated with the operation and support of the rig(s) would decrease considerably, reducing the overall impact of operations. Impacts resulting from the Proposed Action would be localized within the Proposed Action Area as captured by the modeling domain (Figure 4.2.3-1), with the highest level of impacts at the shoreline area closest to the LDPI and lessening moving inland. The air quality in the areas surrounding the project would recover and return to pre-project levels shortly after the completion of the project. Due to these impact criteria the overall impact on Air Quality from Alternative 3B are expected to be Moderate to Major for routine activities, Minor for small spills, and Moderate for a large spill.

4.2.3.4. Alternative 4 – On-shore Processing

Under this alternative, oil and gas processing would be relocated to one of two onshore locations. Emissions from the onshore processing facilities located on SOA lands or within SOA waters would be regulated and potentially controlled by ADEC, rather than BOEM.

Alternative 4A: Relocate Oil and Gas Processing to Endicott

The plan changes outlined in Section 2.2.5 would impact Phases 1 and 2 of the air quality impact scenarios. Under this alternative the jurisdiction of Air Quality would change such that ADEC is the permitting authority of Endicott Production Facility and existing permits may need to be revised due to this Alternative. BOEM would retain Air Quality jurisdiction of the LPDI and Hilcorp would need to submit an updated modeling analysis to demonstrate that the stationary sources and associated activities of the LDPI would not result or contribute to a violation of any ambient air quality standards or air quality increment standards.

Phase 1: Twenty fewer days of construction time would lead to a 13.3% reduction in construction emissions.

Phase 2: Due to the increase in pipeline length there would be an about a 50 day increase in pipeline construction time leading to a 27.8% increase in pipeline construction emissions.

Phase 3: There is no change in potential emissions from the Proposed Action.

Phase 4: There is no change in potential emissions from the Proposed Action. The largest emitter (the drilling rig) would remain offshore and the emitters that would be relocated onshore (Natural gas Power Generators) are very small in comparison.

Under Alternative 4A, during Phase 1, Figure 4.2.3-8 shows that there is a decreased likelihood of violating the NAAQS for the 1 hour NO₂ standard as compared to the Proposed Action. During Phase 2, Figure 4.2.3-8 shows that there is a small increase in the likelihood of violating the NAAQS for the 1 hour NO₂ standard.

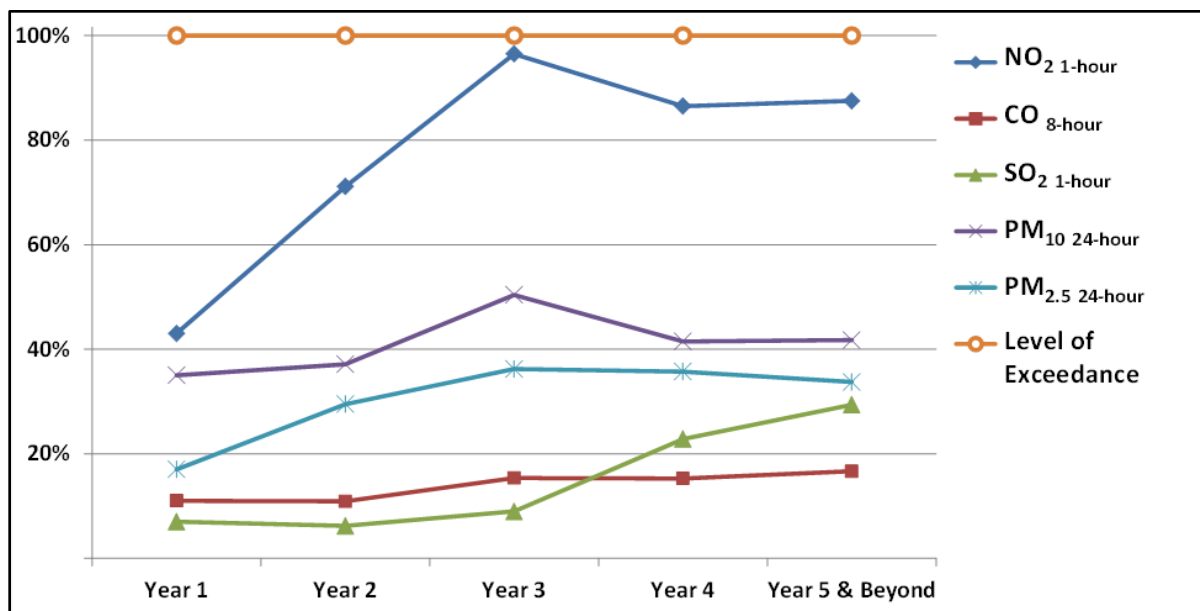

Figure 4.2.3-8. Alternative 4A NAAQS Comparison.

Figure 4.2.3-9 shows that, although there is a slight increase and decrease of emissions during the project, no pollutant comes near the Class II MAI limit. Overall, with no estimated change in the emissions from Phase 4, the impacts of Alternative 4A on air quality would be essentially the same as those for the Proposed Action.

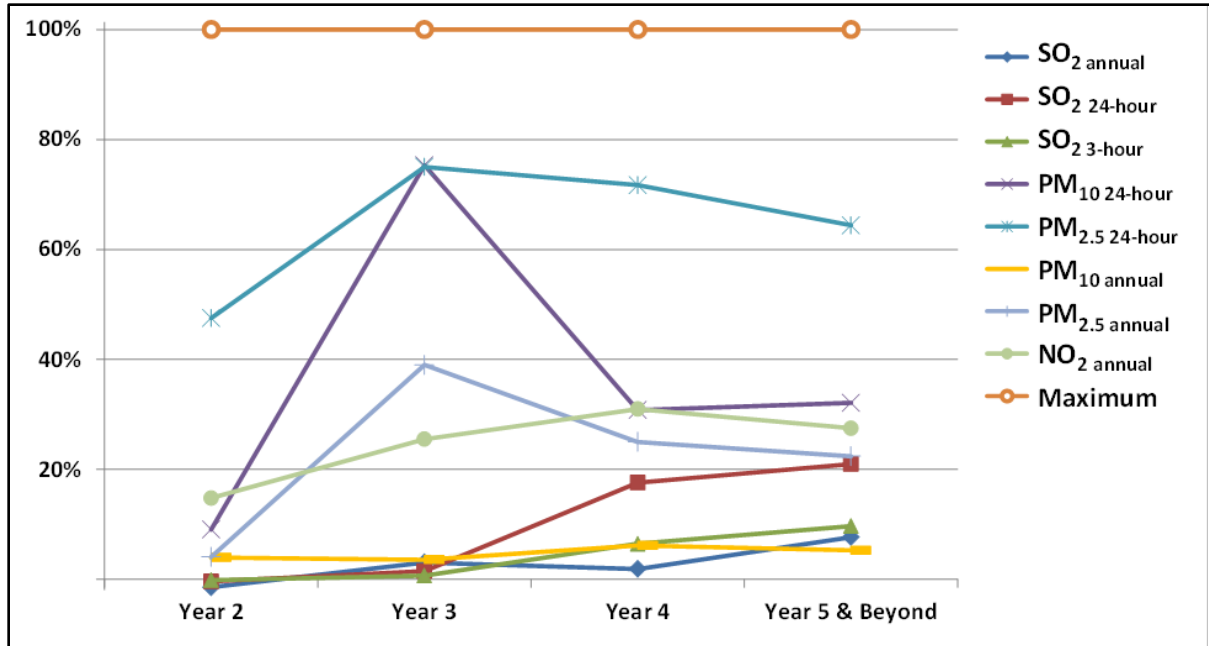

Figure 4.2.3-9. Alternative 4B Class II Comparison.

Conclusion for Alternative 4A

Impacts of Alternative 4A on air quality would be essentially the same as those the Proposed Action. Routine activities under Alternative 4A would have a measureable impact on Air Quality with low to medium intensity due to NO₂ 1-hour being estimated at >50% but <100% of the NAAQS. The impacts would be temporary and interim, over the 25-year lifetime of the Proposed Action. Construction emissions and their resulting impacts would be limited to the first 3-5 years of the project. Once the process of drilling has been largely completed (2nd Qtr. Execute Year 5) and the operation shifts toward production, emissions associated with the operation and support of the rig(s) would decrease considerably, reducing the overall impact of operations. Impacts resulting from the Proposed Action would be localized within the Proposed Action Area as captured by the modeling domain (Figure 4.2.3-1), with the highest level of impacts at the shoreline area closest to the LDPI and lessening moving inland. The air quality in the areas surrounding the project would recover and return to pre-project levels shortly after the completion of the project. Due to these impact criteria the overall impact on Air Quality from the Proposed Action are expected to be minor for routine activities, negligible for small spills, and minor for a large spill.

Alternative 4B: Relocate Oil and Gas Processing to a New Onshore Facility

The plan changes outlined in Section 2.2.5 would impact Phases 1 and 2 of the Air Quality impact scenarios. Under this alternative the jurisdiction of Air Quality would change such that ADEC would be the permitting authority for the new onshore facility. BOEM would retain Air Quality jurisdiction of the LPDI and Hilcorp would need to submit an updated modeling analysis to demonstrate that the stationary sources and associated activities of both facilities would not result or contribute to a violation of any ambient air quality standards or air quality increment standards.

Phase 1: Due to a net 8 days less construction time (20 days less for proposed LDPI construction; 12 additional days for on-shore pad construction) there would be a 5.3% decrease in construction emissions.

Phase 2: Due to additional pipeline and facility requirements about 15 additional days of construction would lead to an 8.3% increase in construction emissions.

Phase 3: There is no change in potential emissions from the Proposed Action.

Phase 4: There is no substantial change in potential emissions from the Proposed Action. The largest emitter (the drilling rig) would remain offshore and the emitters that would be relocated onshore (natural gas power generators) are very small in comparison.

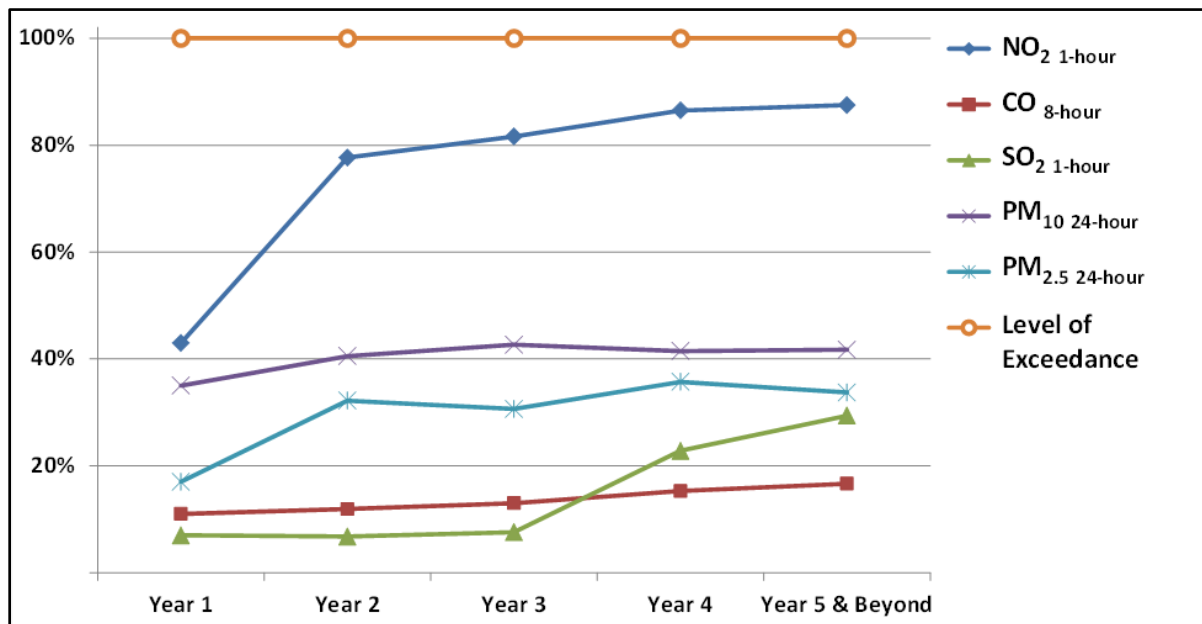

Figure 4.2.3-10. Alternative 4B NAAQS Comparison.

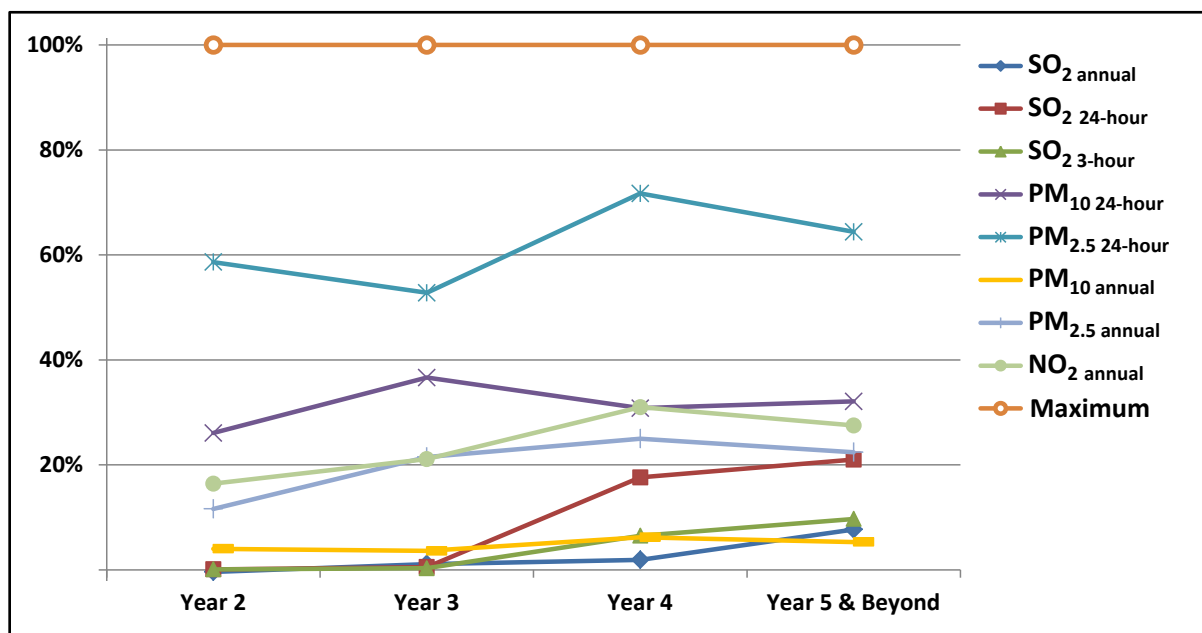

Figure 4.2.3-11. Alternative 4B Class II MAI Comparison.

Conclusion for Alternative 4B:

During Phase 1, Figure 4.2.3-10 shows that there is a decreased likelihood of violating the NAAQS for the 1 hour NO₂ standard as compared to the Proposed Action. During Phase 2, Figure 4.2.3-11 shows that there is a small increase in the likelihood of violating the NAAQS for the 1 hour NO₂ standard. Figure 4.2.3-11 shows that although there is a slight increase and decrease of emissions

during the project no pollutant came near the Class II MAI limit. Overall, with no estimated change in the emissions from year 4 and all subsequent years of this project, the impacts of Alternative 4B on air quality would be essentially the same as those for the Proposed Action.

Impacts of Alternative 4B on air quality would be essentially the same as those for the Proposed Action. The routine activities under Alternative 4B would have a measureable impact on Air Quality. The impacts would have low to medium intensity due NO_2 1-hour being estimated at >50% but <100% of the NAAQS. The impacts would be temporary and interim, over the 25-year lifetime of the Proposed Action. Construction emissions and their resulting impacts would be limited to the first 3-5 years of the project. Once the process of drilling has been largely completed (2nd Qtr. Execute Year 5) and the operation shifts toward production, emissions associated with the operation and support of the rig(s) would decrease considerably, reducing the overall impact of operations. Impacts resulting from the Proposed Action would be localized within the Proposed Action Area as captured by the modeling domain (Figure 4.2.3-1), with the highest level of impacts at the shoreline area closest to the LDPI and lessening moving inland. The air quality in the areas surrounding the project would recover and return to pre-project levels shortly after the completion of the project. Due to these impact criteria the overall impact on Air Quality from the Proposed Action are expected to be minor for routine activities, Negligible for small spills, and Minor for a large spill.

4.2.3.5. Alternative 5 – Alternate Gravel Sources

Potential impacts on air quality under Alternative 5A, 5B or 5C would not differ substantially from those described for the Proposed Action Alternative 1. The air quality impact analysis from the Proposed Action mine site included an estimated 24 trucks hauling gravel to the proposed LDPI. This is greater than the estimated truck use at 12, 15, and 22 trucks for Alternatives 5A, 5B or 5C, respectively.

Conclusion for Alternative 5A: Impacts of Alternative 5A on air quality would be essentially the same as those for the Proposed Action: Minor for routine activities, Negligible for small spills, and Minor for a large spill.

Conclusion for Alternative 5B: Impacts of Alternative 5B on air quality would be essentially the same as those for the Proposed Action: Minor for routine activities, Negligible for small spills, and Minor for a large spill.

Conclusion for Alternative 5C: Impacts of Alternative 5C on air quality would be essentially the same as those for the Proposed Action: Minor for routine activities, Negligible for small spills, and Minor for a large spill.

4.2.4. Climate Change

The activities under the Proposed Action and its alternatives would produce GHG emissions, including carbon dioxide (CO_2), methane (CH_4), and nitrous oxide (N_2O). These GHG emissions would contribute to climate change. The analysis below quantified projected GHG emissions that would occur from the Proposed Action. These projected GHG emissions serve as a proxy for assessing the Proposed Action's contribution to climate change. For this analysis the potential GHG emissions for the action alternatives are expressed as CO_2 equivalents (CO_2e) which are based on potential carbon dioxide (CO_2), methane (CH_4), and nitrous oxide (N_2O) emissions and their respective global warming potential (GWP) values (40 CFR 98, Subpart A, Table A-1).

Using the same assumptions and analysis from Section 4.1.2 and their respective subsections, Table 4.2.4-1 lists the estimated greenhouse gas emissions from the Proposed Action and action alternatives.

Table 4.2.4-1. Potential Annual Greenhouse Gas Emissions of Liberty DPP (tons of CO_{2e}).

Phase	Proposed Action	Alternative 3A	Alternative 3B	Alternative 4A	Alternative 4B	Alternative 5
Phase 1 (yr2)	44,818	47,807	43,025	38,857	41,098	44,818
Phase 2 (yr3)	59,453	64,209	47,562	75,981	64,388	59,453
Phase 3 (yr4)	174,820	174,820	174,820	174,820	174,820	174,820
Phase 4 (yr5 and above)	517,325	719,082	1,117,422	517,325	517,325	517,325

Some of the Alternatives have no estimated change in GHG emissions from the Proposed Action; the estimated emissions of GHG from the Proposed Action are 517,325 tons of CO_{2e}. The emissions from Phase 4 of the Proposed Action and each action alternative is the estimated annual emission from year 5 through the life of the project. The largest variance from the Proposed Action is with Alternatives 3A and 3B. The drilling unit under Alternative 3 would be about 1.5 to 2.5 times larger, respectively, than that under the Proposed Action, leading to a corresponding increase in projected GHG emissions. The physical change in location has negligible levels of effect on greenhouse gases as GHG analysis focuses on gross tonnage of emissions, not concentrations of pollutants onshore. Alternatives 3A and 3B would likely have a greater amount of GHG emissions than the other action alternatives. Because some GHG gases, such as CO₂, may persist in the atmosphere for up to a century, the potential impacts of any source may extend well beyond the active lifetime of the Proposed Action. How these emissions would impact the Proposed Action Area would depend on emissions from the Proposed Action together with emissions on a national and global scale. According to the EPA's Greenhouse Gas Reporting Program (GHGRP) in 2015 the U.S. oil and gas industry as a whole released 231 million metric tons (MMT) of CO_{2e} (EPA, 2016). The contribution to the 2015 GHGRP oil and gas segment from offshore production was 7 MMT CO_{2e} (EPA, 2016).

Lifecycle Greenhouse Gas Emissions

BOEM recently developed a model to examine the lifecycle GHG emissions associated with OCS oil gas development activities both pre- and post-production as well as the potential costs to society from these emissions. This includes all operations on the OCS associated with oil and gas leases (exploration, development and production), the onshore processing (refining, and storage) the delivery of these products to the final consumer, and then the consumption of the oil and gas products. BOEM's programmatic analysis includes an explanation of relevant assumptions, and is contained in BOEM's 2017-2022 Programmatic EIS, Section 4.2.1.2 (USDOJ, BOEM, 2016a). The model also analyzes a No Action alternative which accounts for the CO_{2e} contributions associated with the lifecycle CO_{2e} emissions associated with replacement fuels (anticipated to be a mix of coal, oil, natural gas, and renewables), and also accounts for the estimated marginal reduction in energy demand.

BOEM utilized this model, and the analysis contained in the 2017-2022 Programmatic EIS, to evaluate lifecycle GHG emissions from the Proposed Action. BOEM estimates that 64,570,000 total metric tons of CO_{2e} may be produced as a result of the Liberty DPP (Maisonet, Personal Communication, 05/10/2017). The market substitution concept acknowledges that if oil and gas were not produced from the Liberty prospect, other energy sources would be utilized to keep the supply of energy in line with demand. Using this methodology, BOEM estimates that 89,940,000 total metric tons of CO_{2e} may be produced from replacement energy sources under the No Action alternative (Maisonet, Personal Communication, 05/10/2017). Additional detail on GHG emissions for the No Action and Proposed Action and action alternatives are provided in Table 4.2.4-2. The overall lifespan of the development and production activities, as well as the total amount of oil produced from the Liberty prospect would not vary significantly among action alternatives. Thus, the lifecycle of CO_{2e} emissions for all action alternatives would be similar to those for the Proposed Action.

Table 4.2.4-2. Lifecycle GHG Emissions.*

Alternative Type	CO _{2e}
No Action	64,570,000
Proposed Action and Action Alternatives	89,940,000

Note: * Proposed Action and Action Alternatives are Alternatives 1, 3A, 3B, 4A, 4B, 5A, 5B, and 5C.

Proposed Mitigation Measures

BOEM also evaluated potential mitigation strategies that might reduce the Proposed Action's contribution to climate change. The ideal theoretical mechanism for reducing GHG emissions in the Proposed Action, or any of the action alternatives, would be the use of Carbon Capture Storage/Sequestration devices. However, these devices are currently in their early stages of development and are both cumbersome and expensive. BOEM proposes a simpler, more cost effective approach to the overall reduction in GHG emissions in the form of carbon offsets via reforestation.

The basis of this offset is that the average mature tree can sequester (consume and retain) up to 48 pounds of CO₂ per year through its 40 year lifetime. When reforesting, an average acre can hold up to 1,500 new trees. In its 2017 budget justification, the U.S. Forest Service (USFS) declared that it had identified over a million acres of National Forest System lands that could benefit from reforestation (USFS, 2016). In the preceding year the Forest Service reforested over 190,000 acres of public land and has a goal of reforesting 180,000 in the upcoming year. These efforts are accomplished with the help of non-profit partners such as the National Forest Foundation (NFF) and civic groups who contribute to the agency's capacity for reforestation through partnerships and matching fund agreements. Through these partnerships, the NFF and the Forest Service have been able to reforest areas of public land at 1:1 ratio of dollar to tree.

BOEM proposes and analyzes two levels of mitigation: 1) a partial project carbon offset, and 2) a total project carbon offset.

A partial project carbon offset is inspired by the goal outlined in the Clean Power Plan wherein the United States has set the goal is to reduce GHG emissions by 32% (80 *FR* 64661, October 23, 2015). BOEM proposes that the lessee directly or indirectly (via NFF or USFS) assist in the reforestation of 4,600 acres of public lands. This proposed offset assumes the average acre of reforested land can hold 1,500 new trees, and that each tree at maturity can sequester 48 lbs of CO₂. The addition of 4,600 acres of mature reforested land would lead to an estimated 165,000 tons of annual carbon (CO₂) sequestration which would offset 32% of the annual GHG emissions that the facility at LDPI would emit.

Under this proposal, the Proposed Action's impact on GHG emissions would be reduced to zero. BOEM proposes that the Lessee directly or indirectly (via NFF or USFS) assist in the reforestation of 9,000 acres of public lands. This proposed offset again assumes the average acre of reforested land can hold 1,500 new trees, and that each tree at maturity can sequester 48 lbs of CO₂. During the lifespans of the Proposed Action and that of trees at 25 and 40 years, respectively, it would only require 9,000 acres of mature forest to reduce the lifetime carbon emissions of the the facility at LDPI to zero.

4.3. Biological Environment

4.3.1. Lower Trophics

4.3.1.1. The Proposed Action

Development

In the marine and estuarine environment, habitat alteration would occur during the development activities. Construction of the LDPI and pipeline trenching would affect benthic, epontic, and pelagic invertebrates (discussed below). The Boulder Patch, in particular, is expected to be impacted by construction activities. Until the disposal well is drilled, most wastewater would be hauled offsite for disposal at a permitted facility. The only ongoing discharge during development is wastewater from the STP. Construction and secondary containment dewater would likely occur during the first two years of construction, after which they would be injected in the disposal well. All discharges would be required to comply with the terms and conditions of the NPDES permit.

Production

Production activities in the Proposed Action would take place on the LDPI, in the marine environment, and onshore. Habitat alteration is generally not expected to occur during production of the Proposed Action, as production activities are based on the proposed LDPI and do not require changes to the seafloor. Maintenance of existing structures would occur. Physical presence of the LDPI may provide new hard-substrate habitat for benthic invertebrates. Water intake structures for seawater treatment could affect organisms in the water column, such as zooplankton and fish larvae. The only ongoing NPDES discharge anticipated during the production is wastewater from the STP. As discussed in Section 3.2.1, the current lower trophic community may be altered by climate change processes. However, the impact producing factors and the impacts described below are not expected to differ as a result of those climate change processes.

Decommissioning

Habitat alterations are expected through the removal of LDPI armoring and gradual erosion of the LDPI base. The subsea pipeline would be flushed of all contaminants, have its ends sealed, and be left in place. Decommissioning activities are expected to increase the turbidity through resuspension of sediments as the proposed LDPI is worn away by currents.

Impacts Include:

Habitat Alteration:

For the purposes of this DEIS, BOEM uses several estimates of acreage in the Project Area. NOAA waterbody data (<https://encdirect.noaa.gov/>) was used to estimate the area of Stefansson Sound as approximately 229,000 acres. University of Texas estimates that the area of Boulder Patch is approximately 20,800 acres. More areas of Boulder Patch community may occur in other parts of Stefansson Sound or the Beaufort Sea, but BOEM uses the historic data from University of Texas. A model of sediment dispersal provided the area of Boulder Patch affected by different phases of LDPI construction (Table 4.3.1-1; Figures 4.2.2-1, 4.2.2-3, 4.2.2-4, 4.2.2-7) (Coastal Frontiers, 2014). Ban et. al (1999) used 10 mg/L excess turbidity as the threshold for impacts to kelp; BOEM has used that same designation in this DEIS.

Table 4.3.1-1. Sediment Plume Acreage Estimate¹.

Action	Acres of Boulder Patch Habitat Affected	Percent of Boulder Patch Affected	Figure Reference
Island Construction (winter)	330	1.59%	Figure 4.2.2-1
Trench Excavation (winter)	991	4.76%	Figure 4.2.2-3

Action	Acres of Boulder Patch Habitat Affected	Percent of Boulder Patch Affected	Figure Reference
Trench Backfill (winter)	679	3.26%	Figure 4.2.2-4
Trench Backfill Degradation (summer)	200	0.96%	Figures 4.2.2-7

Note: Estimated areal impacts to the Boulder Patch of increased turbidity >10mg/L as a result of LDPI construction activities.

Source: Coastal Frontiers, 2014.

Gravel deposition during LDPI construction would alter the seafloor habitat and could crush benthic invertebrate species, resulting in injury or mortality to individual organisms present in the 24-acre (9.7 ha) footprint. Pipeline trenching and potential maintenance activities on the trenched backfill would also disturb the seafloor and would disturb habitat for benthic species. Many benthic species are sessile (fixed in one place; immobile) or slow-moving, and are not expected to vacate the area. Any invertebrate present during construction activities would likely be killed or injured. Effects of gravel deposition are expected to be short term and limited to the footprint of the LDPI and the pipeline (backfill deposition). The proposed LDPI would be a long-term alteration to 0.01% of the overall habitat in Stefansson Sound. Removal of the armor plating on the LDPI during decommissioning would result in complete removal of habitat for any species that had colonized the proposed LDPI during the production life of the Proposed Action. This nearshore region is frequently exposed to ice scouring and habitat disturbance on an annual basis (Reimnitz and Kempema, 1982; Pritchard, 1980), so the organisms present are adapted to a highly dynamic environment and are expected to recover quickly.

Gravel deposition and pipeline trenching is expected to increase turbidity temporarily as sediments on the seafloor are resuspended in the water column. Localized increases in turbidity and a turbidity plume are expected around the proposed LDPI and pipeline corridor. The plume is expected to move offshore, away from the Sagavanirktok River (Figures 4.2.2-1, 4.2.2-3, 4.2.2-4, 4.2.2-7). This could affect marine benthic and zooplankton species by decreasing visibility, which impacts both predator and prey interactions (De Robertis et. al., 2003), and also by potentially clogging gills and smothering seafloor communities. Changes in water clarity, especially from turbidity, can affect primary productivity and the spring algal bloom (Aumack et al., 2007; Dunton, Schonberg, and McTigue, 2009). In the ice-covered season when construction activities are mostly occurring, the sediment plume (Figure 4.2.2-1) is expected to be limited by the low currents and ice bonding of silt (Toimil and England, 1982; Newbury, 1983). During the spring thaw, sediment from the pipeline trenching may be transported northward towards the Boulder Patch. Currents during the open-water season are higher due to greater impacts from winds (Trefry, et al., 2009; Coastal Frontiers Corporation, 2014), and so the area affected by elevated turbidity would increase. Monitoring of turbidity from previous gravel island constructions in the Beaufort Sea showed increased turbidity around installations during the summer, but detection of increased suspended sediments was unlikely beyond 500 meters (m) from the site (Coastal Frontiers Corporation, 2014). Turbidity would likely return to ambient levels once construction activities are completed, which means that for the majority of the life of the project, local turbidity would not be increased. During the production phase, localized turbidity would likely be increased above ambient levels as a result of TSS concentrations in the ongoing STP discharge. However, any elevated TSS or turbidity is expected to be quickly diluted to background levels by local currents and tides. Decommissioning activities are expected to increase the turbidity through resuspension of sediments as the proposed LDPI is worn away by currents (Section 4.1.1). Impacts on benthic and planktonic invertebrate communities from changes in turbidity are expected to be short term and localized compared to the greater area of Stefansson Sound.

In contrast to the general benthic communities of Stefansson Sound, impacts to the Boulder Patch from construction activities are expected to be more pronounced. The Boulder Patch is a specialized type of habitat that hosts some of the most diverse biological communities in the entire Beaufort Sea. (Dunton et.al., 1982). Given the estimated boundaries of the Boulder Patch, modeling of the sediment

plume suggests that a relatively small area of heavy Boulder Patch coverage would be affected (Table 4.3.1-1; Figures 4.2.2-1, 4.2.2-3, 4.2.2-4, 4.2.2-7; Coastal Frontiers, 2014). The amount of light available in the marine environment is an important factor in annual production, particularly for the Boulder Patch, although a great deal of growth occurs in naturally dark conditions (Dunton et al., 1982; Dunton et al., 2009). Excess turbidity would decrease the amount of light, which could alter and decrease primary productivity. Growth of kelp in the Boulder Patch would be impacted, and this would have cascading effects on the biota that rely on the Boulder Patch for habitat and feeding. Studies on the Boulder Patch have shown that recovery after a disturbance is a long-term process (Martin and Gallaway, 1994; Konar, 2007; Konar 2013). Recovering from the impacts from excess turbidity, including limited primary productivity as well as sediment smothering, could take decades. Habitat loss in the Boulder Patch could be mitigated slightly by addition of new hard-bottom habitat from the LDPI, which is a key characteristic of Boulder Patch distribution. Decommissioning activities may again temporarily increase turbidity in the Boulder Patch, however, the severity of the impact is expected to be minor because the island would be worn down through natural processes (see Section 4.1.1), and the majority of fine sediment suspension would primarily occur during construction.

Ice habitat for epontic organisms would be affected by cutting excisions in the ice to allow for gravel deposition and subsea pipeline installation. This would remove some ice algae and alter the habitat of ice-associated species, like amphipods (Lonne and Gullikson, 1989; Gradinger and Bluhm, 2004), though there is a large area of other available ice habitat for epontic communities.

Overall, the initial construction of the LDPI would have the most adverse impact on benthic invertebrates, zooplankton, and the Boulder Patch. Outside of the Boulder Patch, these impacts (crushing, smothering, and increased turbidity) are not expected to have a population level effect, as the size of the area impacted relative to the overall amount of benthic habitat available in Stefansson Sound is small (0.01% of the overall habitat in Stefansson Sound). Once the proposed LDPI is in place and construction activities are over, benthic communities around the LDPI are expected to recover within a few years. The proposed LDPI itself may mitigate adverse impacts by providing habitat for species that prefer hard-bottom substrates. Because of the duration of the Proposed Action, the general habitat alteration impacts are expected to be long-term though the footprint would be limited and localized to the immediate vicinity of the LDPI.

The Boulder Patch, due to its low tolerance for habitat disturbances, would not recover as quickly. Although the effects of sedimentation from proposed LDPI construction and decommissioning would affect only a relatively small portion (<5%) of the known Boulder Patch area, it could have long-term impacts on this specialized environment.

Physical Presence:

Numerous vessel roundtrips would occur between the offshore facilities and the onshore facilities in open-water months during the life of the Proposed Action. Pressure waves from vessel hulls could displace plankton and cause injury or mortality. Ice roads are not expected to impact lower trophic organisms, as the roads would be outside of the normal habitat of this resource. The number of individual planktonic organisms that are expected to be impacted by vessels is small relative to the overall number in Stefansson Sound. Additionally, one to two barge trips per year may transit through Dutch Harbor, and would occur in areas outside of the region described in section 3.2.1. Impacts from these limited barge trips to the Chukchi Sea are the same as described in the BOEM Chukchi Sea Planning area Lease Sale 193 Second SEIS (USDOJ, BOEM, 2015).

Although the LDPI is a long-term addition to Stefansson Sound, it is a highly localized impact. Benthic organisms are expected to resume use of the area around and on the base of the proposed LDPI after initial construction has been completed. It is expected that the LDPI, once constructed, could provide hard substrate habitat for benthic species. This could mitigate the impacts to the

Boulder Patch due to the initial habitat loss by providing new substrate for colonization. Lights on the proposed LDPI during all phases may attract predators of zooplankton and fish (Shaw et al., 2002). The impact from physical presence of the LDPI would gradually disappear during decommissioning as the gravel is carried away by currents, but that process would take many seasons (See Section 4.1.1). The proposed pipeline would be buried and covered with the trenched material, so little to no impacts are expected on invertebrate communities after the initial construction disturbance and recovery.

The addition of the LDPI in Stefansson Sound is unlikely to alter currents or wind patterns (See Section 4.2.2.1). The presence of the island is not expected to impact the distribution or movement of plankton because these organisms are wind and current driven.

Water intake structures can result in the entrainment (any life stages of fish and shellfish in the intake water flow entering and passing through an intake structure, which excludes those organisms that are collected or retained by a sieve with a maximum opening dimension of 0.56 inches) and/or impingement (entrapment of any life stages of fish and shellfish on the outer part of an intake structure or against a screening device during periods of intake water withdrawal, which includes those organisms collected or retained on a sieve with maximum distance in the opening of 0.56 inches and excludes those organisms that pass through the sieve) of all life stages of fish and shellfish, and plankton. EPA's NPDES permit requires HAK to develop and implement a Best Management Practice (BMP) Plan to minimize the entrainment and impingement mortality of fish and shellfish. Specifically, the NPDES permit requires HAK to "select and implement seawater intake structure design and construction technologies or operational measures for minimizing entrainment and impingement mortality of fish and shellfish." This requirement is consistent with the Cooling Water Intake Regulations found at 40 CFR Part 125.84(c)(4), which regulates cooling water intake facilities with design flows greater than 2 MGD. Although the proposed STP facility would not be designed for cooling purposes, it would withdraw approximately 4.4 MGD, and, without proper design controls, could have the potential to cause entrainment and impingement mortalities. Compliance with these NPDES permitting requirements would minimize the effect of water intake structures on all life stages of fish and shellfish, and plankton.

The wastewater discharges associated with the LDPI consist of conventional pollutants, which are designated under Section 304(a)(4) of the CWA as BOD, TSS, pH, fecal coliform, and oil and grease. These conventional pollutants are not expected to bioaccumulate or persist in the environment. With the exception of the ongoing discharges from the STP during the life of the project, all other authorized discharges would be temporary and short-term.

Pollutants not classified as conventional or toxic, such as temperature, are considered to be "nonconventional." The potable water treatment and the STP processes may result in elevated temperatures in the effluent, as compared to the ambient receiving waterbody conditions. To ensure those discharges would not result in an unreasonable degradation of the marine environment, the NPDES permit requires weekly temperature monitoring of the influent and effluent for those systems.

Additionally, wastewater discharges from the potable water treatment system and the STP may contain trace amounts of chemicals. HAK has indicated that both systems may require the use of maintenance chemicals, such as biocides, clarifying agents, descalers, and/or chlorination/dechlorination chemicals. The STP has been designed to minimize the release of these chemicals to the environment and the potable water treatment reject wastewater is expected to be disposed of through the disposal well. However, the NPDES permit requires whole effluent toxicity testing semi-annually and quarterly on effluent samples from the potable water treatment reject wastewater and the STP, respectively, during periods when chemicals are used and when the applicable waste streams are discharged to surface waters. It is expected that the discharged water

would rapidly dilute, mixing to background levels. Effects of water intake and discharge would be localized to the LDPI and are not expected to have population-level impacts.

The proposed LDPI, once constructed, could provide hard substrate habitat for benthic species. This could affect the Boulder Patch by providing new substrate for colonization, which could mitigate the impacts of the initial habitat loss. Lights on the proposed LDPI during all phases may attract predators (Shaw et al., 2002). The impact from physical presence of the LDPI would gradually disappear during decommissioning as the gravel is carried away by currents, but that process would take many seasons. Although the LDPI is a long-term addition to Stefansson Sound, benthic organisms are expected to resume use of the area around and on the base of the proposed LDPI after initial construction has been completed. The pipeline would be buried and covered with the trenched material, so little to no impacts are expected on invertebrate communities after the initial construction disturbance and recovery.

Water intake structures can entrain zooplankton and phytoplankton, which can result in various adverse impacts on plankton communities, including decreased biomass and productivity of entrained heterotrophic bacteria and phytoplankton, reduced survival of entrained zooplankton and other metazoans, and reduced diversity of the zooplankton community (Choi et al., 2012). NPDES permit requirements ensure that the best available technology is used to minimize impingement and entrainment, including reduced water flow and technological controls designed to decrease mortality of organisms less than 0.56 inches (1.4 cm). Adherence to permitting regulations would minimize the effect of water intake structures on plankton and fish larvae. Discharged water may be a different temperature than the ambient levels, and may contain trace amounts of chemicals. However, discharged water would rapidly dilute, mixing to background levels. Effects of water intake would be localized to the LDPI and are not expected to have population-level impacts.

Overall, invertebrates would be affected by the physical presence of vessels and the proposed LDPI in the marine and coastal environments. The LDPI may affect the movements of plankton, but the impacts would be negligible. Water intake and discharge impacts would be minor. The physical presence of ice roads used for winter construction activities is not expected to impact marine or estuarine invertebrates. The existence of the LDPI would span at least three decades, but would also provide habitat for benthic invertebrates. The pipeline would be buried, and aside from habitat alteration impacts discussed earlier, is not expected to impact invertebrate communities. General impacts are expected to be localized to the proposed LDPI and gravel mine sites.

Oil Spills

Accidental events could include small (<1,000 bbl) and large (\geq 1,000 bbl) spills stemming from the LDPI or the pipeline. Accidental discharge of oil can occur during development, production or decommissioning. Small and large oil spills are considered accidental events, and the Clean Water Act and Oil Pollution Act include regulatory and liability provisions designed to reduce damage to natural resources from oil spills. Oil spills are further discussed in Section 4.1.1-1.

Small Oil Spills (<1,000 bbl)

Many factors determine the degree of damage from a spill on plankton and benthic communities, including the size and duration of the spill, geographic location of the spill, and season. In whatever quantities, accidental oil spills can affect lower trophic organisms and their habitats. For much of the year, Stefansson Sound is covered in first year ice. Small spills are expected to be contained on either the LDPI or landfast ice. Clean up of oil spills before they enter the water column would mitigate the impacts of oil spills on lower trophic organisms. In open-water conditions, small spills tend to degrade within hours to days in the marine environment, although a small proportion of the heavier fuel components could adhere to particulate matter in the upper portion of the water column and sink.

Benthic and planktonic invertebrates are exposed to oil in different ways and vary in their ability to avoid exposure (Blackburn et al., 2014).

Plankton. Mortality of zooplankton has been shown to be positively correlated with oil concentrations (Lennuk et al., 2015). Spills that are not immediately lethal can have short- or long-term impacts on biomass and community composition, behavior, reproduction, feeding, growth and development, immune response, and respiration (Auffret et al., 2004; Bellas et al., 2013; Blackburn et al., 2014). Zooplankton are especially vulnerable to acute crude oil pollution, showing increased mortality and sublethal changes in physiological activities (e.g., egg production) (Lee, Winters, and Nicol, 1978; Linden, 1976; Moore and Dwyer, 1974). Zooplankton may also accumulate Polycyclic Aromatic Hydrocarbons (PAHs) through diffusion from surrounding waters, direct ingestion of micro droplets (Berrojalbiz et al., 2009; Lee, Koster, and Paffenhof, 2012), and by ingestion of droplets that are attached to phytoplankton (Almeda et al., 2013). Bioaccumulation of hydrocarbons can lead to additional impacts on higher trophic level consumers that rely on zooplankton as a food source (Almeda et al., 2013; Blackburn et al., 2014).

Oil spill impacts to phytoplankton include changes in community structure and increases in biomass, attributed to the effects of oil contamination and decreased predation due to zooplankton mortality (Abbrian et al., 2011; Ozhan, Parsons, Bargu, 2014). Ozhan, Parsons, Bargu (2014) reported that the formation of oil films (or slicks) on the water surface can limit gas exchange through the air-sea interface and can reduce light penetration into the water column by up to 90%, which would limit phytoplankton photosynthesis (González et al., 2013). The toxicity of oil is affected by weathering, and varies with temperature and light; the sensitivity of phytoplankton to oil toxicity may increase under these nutrient limited conditions. Additionally, some phytoplankton species are more tolerant of oil exposure than others, and the tolerance to low and high concentrations varies among species. Phytoplankton populations can change quickly on small temporal and spatial scales making it difficult to predict how a phytoplankton community as a whole would respond to an oil spill. González et al. (2013) concluded that the assessment of the impact of oil spills on phytoplankton communities should not be a priority of environmental monitoring efforts after a spill, since impacts can be very subtle or even undetectable.

Zooplankton communities from coastal habitats (i.e., inlets, estuaries, enclosed bays) with restricted hydrodynamics are considered more susceptible to long-term effects. Planktonic communities also have a higher capacity for recovery from the effects of oil spill pollution over the long term due to their short lifecycle and high reproductive capacity (Abbrian et al., 2011). Planktonic communities drift with water currents and recolonize from adjacent areas; these attributes and short life cycles of plankton facilitate relatively rapid recovery of the population following a disturbance. Several studies found that zooplankton communities reestablish several weeks to months after an oil spill, indicating a high capacity for recovery (Al Yamani et al., 1993; Varela et al., 2006).

The microbial community also can be affected by an offshore oil spill. Changes in the microbial community because of an oil spill could have substantial impacts on the rest of the marine ecosystem. However, several laboratory and field experiments and observations have shown that impacts to planktonic and marine microbial populations generally are short lived and do not affect all groups evenly, and in some cases stimulate growth of important species (González et al., 2009; Graham et al., 2010; Hing et al., 2011).

Benthic Invertebrates. The zooplankton community also contains free-floating embryos and larvae of invertebrates that inhabit the sediment as adults, including sea urchins, mollusks, and crustaceans. The planktonic stages of benthic invertebrates are more sensitive to pollutants than adults and their survival is critical to the long-term health of the adult populations (Anselmo et al., 2011; Bellas et al., 2013; Blackburn et al., 2014). The eggs and larvae of planktonic oysters exposed to oil show impaired development and decreased settlement of juveniles (Blackburn et al., 2014). A Blackburn et al. (2014)

review of studies conducted after the *Prestige* oil tanker spill off the northwest coast of Spain reported that sea urchin embryo development was inhibited by as much as 50% when fuel oil content in the water was >3.8%; that oil-polluted seawater collected from coastal sites was more toxic than contaminated sediment to embryos and larvae of bivalves and echinoderms; and that oil impaired growth of sea urchin and oyster larvae and development of mussel embryos.

Impacts of oil to benthic invertebrates vary depending on life history, feeding behavior, and ability of a species to metabolize toxins (Blackburn et al., 2014). Oil would affect benthic communities as it washes ashore or as it sinks and becomes bound to sediments. Benthic invertebrates impacted by an oil spill can occur in habitats from the intertidal coastal areas to the barrier islands; some are mobile, while others are sessile. Oil and its weathered byproducts bind and become buried in sediment resulting in long-term persistence in the environment, increasing exposure time of benthic invertebrates (Blackburn et al., 2014; Peterson et al., 2003). Benthic invertebrates are susceptible to long-term exposure and can accumulate higher levels of sediment-bound contaminants (NRC, 2003; Peterson et al., 2003). Chronic exposure to oil and its byproducts can cause cellular damage and impair reproduction, growth, and development in marine invertebrates (Bellas, 2013; Blackburn et al., 2014). Benthic invertebrates exposed to hydrocarbons for long periods may accumulate higher levels of hydrocarbons than pelagic organisms (Blackburn et al., 2014). Exposure to hydrocarbons is amplified for invertebrates that are part of the pelagic zooplankton as embryos and larvae, and live in the sediment as adults. These life habits potentially lead to an increased risk of long-term population-level impacts as these species are exposed to oil in multiple habitats and life stages (Blackburn et al., 2014). Filter-feeding invertebrates such as mussels and oysters can ingest oiled organic particles, and can uptake oil dissolved in the water column which then bioaccumulates in their tissues (NRC, 2003). Bellas et al. (2013) studied the impacts of weathered oil on sea urchins and mussels, and showed a progressive increase in oil toxicity with weathering over 80 days. Conversely, populations of invertebrates living within the sediments (e.g., polychaetes, nematodes, oligochaetes) have been shown to increase in areas where low concentrations of hydrocarbons are found (Blackburn et al., 2014; Jewett et al., 1999). Oil spills have been shown to result in a severe reduction or complete disappearance of amphipods and echinoderms, and the subsequent replacement by opportunistic polychaetes in oiled areas (Blackburn et al., 2014; Jewett et al., 1999). Hale et al. (2011) showed that deposit-feeding and burrowing benthic invertebrates are impacted by chronic exposure to hydrocarbons in polluted sediments and their populations can continue to fluctuate as they respond by building shallower burrows to avoid sediment-bound oil, leading to greater exposure on the surface, reduced mobility, and increased susceptibility to predation (Blackburn et al., 2014). The varying responses of benthic invertebrates to oil can lead to long-term alterations in the structure and biodiversity of benthic communities (Carls, Harris, and Rice, 2004; Jewett et al., 1999).

Blackburn et al. (2014) conducted a literature review of oil spill impacts to various invertebrates and reported the following findings:

- Echinoderms (e.g., sea urchins, sea stars, and sea cucumbers) can be particularly sensitive to oil with spills resulting in mass die-offs and strandings of adult sea urchins and sea stars. Early planktonic life stages exposed to oil may show impaired embryogenesis and larval growth.
- Mollusks (e.g., mussels, oysters, and snails) are highly sensitive to oil. Oil ingestion through filter-feeding results in bioaccumulation of hydrocarbons. The limited capacity of this group to metabolize oil leads to prolonged exposure and negatively affects feeding, growth, reproduction, embryo development, and immune response. Snails and limpets in intertidal rocky shores and estuaries have shown high levels of mortality after oil spills and reduced recruitment of juveniles for years afterwards, and sublethal concentrations impair their mobility, foraging behavior, and reproduction.
- Crustaceans (e.g., crabs, amphipods, lobsters, and shrimp) suffer substantially reduced populations and strandings after oil spills. Crustaceans can be exposed to oil that is buried in

sediments for long periods of time, and chronic exposure can impair feeding, mobility, development, and reproduction.

- Polychaetes display complex and varied responses to oil pollution, including increases in abundance following the mortality of other invertebrates, rapid colonization of damaged habitat, and mortality resulting in reduced populations.

Summary and Conclusions for Small Spill Impacts

Overall, oil in open water can cause immediate mortality in zooplankton. In addition, because zooplankton includes immature stages of invertebrates that inhabit benthic habitats as adults, mortality may result in long-term decreases in abundance and changes in community composition. These early life stages are more sensitive to oil compared to adults, and thus zooplankton mortality has implications for recruitment of juveniles into existing adult populations. To compound the situation, benthic invertebrates also are affected adversely as adults by oil that is trapped and buried in sediments as well as mussel and oyster beds, where it can persist long-term.

Spills <1,000 bbl would still have some localized adverse effects to plankton and benthic organisms. Adverse effects to lower trophic species could be compounded for a spill 200-1,000 bbl (though only one spill 200-1,000 bbl is assumed for this analysis). Toxic effects on organisms (particularly early life stages) could occur in the immediate area of a spill. Even at low concentrations that are not directly lethal, some contaminants in oil can cause sublethal effects on sensory systems, growth, and behavior of invertebrates, or may be bioaccumulated.

For isolated small spills, which would be short term and localized, minor impacts are expected to lower trophic organisms. Population-level effects would not likely be detectable for small, isolated accidental spills, especially if they are contained by the LDPI or ice and are cleaned up before they enter the water column. Chronic small spills that enter the water column may have a cumulative effect in the environment, which could lead to multi-generational, long-term effects on benthic communities. However, plankton is expected to repopulate the area via currents and no long-term impacts are expected. Over the life of the Proposed Action, the impacts from isolated small spills would be minor, but Impacts from chronic small spills from the same location, such as the LDPI, could range up to moderate. The impacts from small spills could be minor to moderate. The disturbances and associated adverse impacts on lower trophic organisms from accidental spills may be reduced through the operating procedures required by regulatory agencies. Potential spill impacts would be reduced by incorporation of a spill prevention, control, and countermeasure plan into proposed LDPI operations.

Large Oil Spill ($\geq 1,000$ bbl)

Although unlikely (Section 4.1.1.2; Appendix A), for purposes of analysis, BOEM estimates that one large oil spill would occur during the life of the Proposed Action. A large oil spill can occur for many possible reasons, including equipment malfunction, pipeline breaks, or human error. Crude oil spills may occur directly from the proposed LDPI or a ruptured pipeline during development and production. Large oil spills could affect benthic and pelagic invertebrates depending on the location, volume, and trajectory of the spill and the time of year it occurs. Spilled oil would dilute slowly in ice-covered conditions, and more swiftly in open-water conditions. Local spill trajectory would depend on tide stage as well as wind and wave direction. In the unlikely event that a large oil spill occurred, the spill and the response would affect lower trophic organisms. The LDPI and pipeline are located within barrier islands, so even though large spills are unlikely, if they occur, the likelihood of contact with part of the shoreline is relatively high. Oil released from a wellhead (subsurface release; loss of well control) or from a pipeline would affect plankton communities because they have no or limited ability to avoid contact with oil. Direct contact with oil would result in the uptake of toxic fractions, physical smothering, and possibly mortality (Blackburn et al., 2014). Results of post-spill studies of plankton communities following the *Deepwater Horizon* spill showed that oil and the

biodegradation of oil can lead to indirect impacts such as inhibition of air-sea gas exchanges, reduced light penetration, and hypoxia resulting from accelerated hydrocarbon degradation (Abbrián et al., 2011; Ozhan, Parsons, Bargu, 2014).

A large spill ($\geq 1,000$ bbl), depending on the season and location, could be difficult to contain and could include lethal and sublethal effects on relatively large numbers of lower trophic level organisms. Lower trophic level organisms in Stefansson Sound and the surrounding region are represented in the OSRA model by ERAs that were identified as important habitat for lower trophic organisms (Appendix A, Table A.1-11); however, only ERAs 75 (Boulder Patch Area), 80 (Beaufort Outer Shelf 1), and 101 (Beaufort Outer Shelf 2) had any contact probabilities $\geq 5\%$. All others had contact probabilities $< 5\%$ and so will not be analyzed further. ERAs 80 and 101 have some instances where the probabilities of contact from a spill would be $\geq 5\%$. Table 4.3.1-2 shows conditional probabilities of contact from a large spill in summer and winter, and the annual probability of contact. The Boulder Patch (ERA 75) has the highest chance of being contacted by a large spill during summer and winter months. A summer spill (July 1–September 30) has probabilities of 54– $\geq 99.5\%$ of contacting ERA 75 based on the number of days spill constituents are permitted to persist in the environment and whether the spill originated at the LDPI (LI) or the offshore portion of the proposed pipeline (PL). Similarly, winter and annual probabilities for contacting ERA 75 were 55– $\geq 99.5\%$. Contact probabilities for ERAs 80 and 101 were generally less than 5% regardless of season, except after 90 and 360 days.

Table 4.3.1-2. Chance by days of a Large Spill on Liberty LDPI or Pipeline Contacting a Given ERA*.

ID	Environmental Resource Area Name	1 day LI	1 day PL	3 days LI	3 days PL	10 days LI	10 days PL	30 days LI	30 days PL	90 days LI	90 days PL	360 days LI	360 days PL
75	Boulder Patch Area (Annual)	>99.5	55	>99.5	57	>99.5	57	>99.5	57	>99.5	57	>99.5	57
75	Boulder Patch Area (Summer)	>99.5	54	>99.5	56	>99.5	56	>99.5	56	>99.5	56	>99.5	56
75	Boulder Patch Area (Winter)	>99.5	55	>99.5	57	>99.5	58	>99.5	58	>99.5	58	>99.5	58
80	Beaufort Outer Shelf 1 (Winter)	<0.5	<0.5	<0.5	<0.5	1	<0.5	3	2	5	3	5	3
101	Beaufort Outer Shelf 2 (Annual)	<0.5	<0.5	<0.5	<0.5	1	<0.5	3	2	6	3	6	3
101	Beaufort Outer Shelf 2 (Summer)	<0.5	<0.5	<0.5	<0.5	1	<0.5	4	3	6	4	6	4
101	Beaufort Outer Shelf 2 (Winter)	<0.5	<0.5	<0.5	<0.5	1	<0.5	3	2	5	3	5	3

Note: Chance of contact of a spill from LDPI (LI) or pipeline (PL) is summarized by days elapsed since spill.

Effects of a large oil spill would be similar to those described for a small oil spill, but the area affected would be larger. The summer months are a period of peak primary productivity, and a large spill at the sea surface under the Proposed Action would result in mortality of plankton in the surface layer. However, the effects on plankton populations would not be measureable for long because of the rapid rate of production; phytoplankton and zooplankton populations are capable of doubling their biomasses within a few days and a couple of weeks, respectively. OSRA modeling indicates that a large oil spill originating from the LDPI would almost certainly impact the Boulder Patch. As with turbidity, limiting the amount of light available for primary production could have negative impacts on the Boulder Patch community, and recovery would be a long-term process. Compounding this with other effects of oil on lower trophic organisms could result in severe impacts to the Boulder Patch.

Large spills under the Proposed Action could affect the water column and benthic habitats offshore and along areas of coastline resulting in mortality of plankton and benthic communities. Depending on timing, duration, size, and location of a large spill, population-level impacts are not likely for plankton or benthic invertebrates, but a spill in the winter would result in a longer recovery period for plankton. Regardless of season, oil reaching the shoreline would result in long-term persistent impacts to benthic invertebrates in the oiled area. A large spill could affect large numbers of benthic invertebrates, and important habitat, like the Boulder Patch. Heavy oiling through direct contact with a spill would likely result in mortality, while lightly oiled lower trophic level organisms may

experience a variety of lethal or sublethal effects. Outside of the Boulder Patch, benthic and planktonic organisms live in an environment that is affected by ice scouring and changing salinity on an annual basis; a relatively quick recovery to benthic communities is expected. However, the impacts of a large spill would be widespread. Overall, impacts to lower trophic level organisms outside of the Boulder Patch from a large spill would be moderate and would depend on the timing, location, and environmental conditions affecting weathering of the oil. The Boulder Patch, given its long recovery time and the impacts of oil exposure on benthic organisms, would have major impacts if a large oil spill were to contact the area.

Spill Response Activities

Spill response activities could include mechanical recovery methods and in-situ burning of spilled materials. Increased vessel traffic, with corresponding increases in vessel discharges and noise, would also be associated with spill cleanup operations.

Planktonic organisms, such as zooplankton (including fish and invertebrate larvae) and phytoplankton, may be affected by mechanical recovery of spilled material, as they are located in the water column and are generally unable to move away from oil without a current, which would carry the spilled material with it. Physical damage from containment and collection procedures could also occur. Lethal impacts may occur to individuals, but would not be at the population level. These effects of mechanical recovery would be short-term and localized to the spill area. Benthic organisms would not likely be affected by mechanical recovery activities occurring at the surface. The effects of mechanical recovery on lower trophic organisms would be minor.

In-situ burning of spilled oil is used to remove oil from the surface and could impact lower trophic organisms in the immediate area due to residue from the burn sinking to the bottom. Death of planktonic organisms is expected in the area of the burn. At the seafloor, residue from a burn can sink and smother benthic organisms. These effects are expected to be short-term and localized to the immediate burn area, and would be considered minor.

Spill impacts and cleanup operations would be influenced by time of year. An oil spill occurring into ice may persist for a longer period of time than during ice-free conditions (Buist et al., 2008; Payne, McNabb, and Clayton, 1991). Should oil be trapped and persist in the environment, the effects on lower trophics would be expected to be greater than for summer response efforts. Natural processes would aid the degradation of the oil and gas released during a large spill, but at a slower rate than in warmer summer waters. Under calm conditions and cold temperatures in restricted waters, vertical mixing and dissolution would be reduced (Buist et al., 2008). A large spill occurring on or under ice would be trapped and persist until the ice melted, allowing the spill to disperse (Drozdowski et al., 2011), and trapped oil can be transported by currents to areas more distant from the site of the accidental spill. Volatile components of the spill would be more likely to freeze into the ice rather than evaporate. Response efforts would be hindered and aided by the presence of ice. Ice would contain a spill (reduce spreading), concentrate it, and may act as a barrier to shoreline oiling. However, ice may also make a spill difficult to detect, locate, and access. Oil trapped under the ice may persist longer in the environment than oil spilled in open water, and have a greater impact on lower trophic organisms.

These effects could be long-lasting and widespread for both the plankton and benthic communities if a large spill occurs, while impacts from a small spill would be localized. Effects are unlikely to be population-level, though, as planktonic communities can quickly recover, and benthic community impact would be limited spatially by the settling of oil.

Conclusion

Overall, impacts to lower trophic organisms from routine activities associated with the Proposed Action, which includes isolated small spills, would be primarily short-term and localized, and thus

minor. While the LDPI itself would be a long-term presence, impacts would have little to no impacts on benthic, epontic, and pelagic communities, and would eventually be eliminated. Impacts from isolated small oil spills on lower trophic organisms outside of the Boulder Patch are also expected to be minor. Impacts from chronic small spills, or in the event of a large spill, impacts could range up to moderate. Impacts to the Boulder Patch, considered as a subset of the lower trophic organisms, from routine activities are expected to be moderate because of long-term impacts to its community structure; recovery is expected to take at least a decade. Impacts from a small spill to the Boulder Patch would have moderate impacts, and large spills would have major impacts.

Mitigation

The Proposed Action includes several design features in LDPI design, construction, and operation to minimize potential impact to the Stefansson Sound lower trophic community. Appendix C describes mitigation measures derived from lease stipulations, design features and BMPs the operator committed to, and requirements and BMPs that other agencies typically require. The measures that minimize impacts to the oceanography and water quality include: LDPI and pipeline route location to minimize direct disturbance and sedimentation from construction; LDPI and pipeline design to minimize size and footprint impacts; proposed LDPI armoring to reduce erosion; the expectation that lower portions of the armor at LDPI may serve as hard bottom habitat that is likely to attract Boulder Patch community colonization; winter construction that provides a stable work platform (ice), with reduced water turbulence and currents; and winter construction avoids the time when the Boulder Patch needs clearer water to fix carbon by photosynthesis (during the Arctic summer). These measures were included in this analysis as part of the Proposed Action. No additional mitigation measures to further reduce impacts to lower trophic systems were identified in the analysis.

4.3.1.2. Alternative 2 (No Action)

Under Alternative 2, the Proposed Action would not occur, and the impacts to the Boulder Patch or lower trophic organisms in Stefansson Sound described above would not occur.

4.3.1.3. Alternative 3 (Alternate locations for proposed LDPI)

Alternative 3A: Relocate LDPI Approximately One Mile to the East

Potential impacts on lower trophic communities under Alternative 3A would be similar to those described for the Proposed Action. The footprint of the proposed LDPI would increase and the pipeline would be longer, which would affect the area vulnerable to crushing and smothering, and could slightly increase the size of the sediment plume. This location would increase the distance between the LDPI and the Boulder Patch, likely resulting in a decrease in impacts to Boulder Patch resources from sedimentation and turbidity. In general, the types of impacts on lower trophic organisms would remain the same, and the increase in footprint size would not change the overall impact designation on invertebrates outside of the Boulder patch from minor. Impacts to the Boulder Patch may decrease slightly, although the increase in sedimentation from the new proposed LDPI size could still allow sedimentation to reach the Boulder Patch. The overall impacts to the Boulder Patch under this alternative would depend on the extent of the sediment plume.

Alternative 3B: Relocate LDPI Approximately 1.5 Miles to the Southwest

Potential impacts under Alternative 3B would be similar to those described for the Proposed Action (Alternative 1). However, the footprint of the proposed LDPI would decrease and the pipeline would be shorter, which would affect the area vulnerable to crushing and smothering, and could slightly decrease the size of the sediment plume. Less gravel would be needed to construct the LDPI. This location would increase the distance between the LDPI and the Boulder Patch by 1.5 miles, resulting in a decrease in impacts to Boulder Patch resources from sedimentation and turbidity. In general, the types of impacts on lower trophic organisms would remain the same, and the decrease in footprint

size would not change the overall impact designation on invertebrates outside of the Boulder Patch. Impacts to the Boulder Patch are likely to decrease, as the sediment plume would be smaller and originate from farther away from the Patch area. The overall impacts to the Boulder Patch under this alternative would depend on whether the sediment plume does reach the Boulder Patch. If that occurs, the impacts would increase, though they would affect a smaller area than the Proposed Action.

Conclusion

Conclusion for Alternative 3A: Impacts of Alternative 3A on lower trophic organisms outside of the Boulder Patch would be essentially the same as those for the Proposed Action: minor for routine activities, minor to moderate for small spills, and moderate for a large spill. Impacts of Alternative 3A on the Boulder Patch may be smaller than the impacts for the Proposed Action: minor to moderate for routine activities, moderate for small spills, and major for a large spill.

Conclusion for Alternative 3B: Impacts of Alternative 3B on lower trophic organisms would be essentially the same as those for the Proposed Action: minor for routine activities, Minor to moderate for small spills, and moderate for a large spill. Impacts of Alternative 3A on the Boulder Patch are likely to be smaller than the impacts for the Proposed Action: minor (potentially moderate) for routine activities, moderate for small spills, and major for a large spill.

4.3.1.4. Alternative 4 (Alternate Processing Locations)

Alternative 4A: Relocate Oil and Gas Processing to Endicott

Potential types of impacts on lower trophic organisms under Alternative 4A would be similar to those described for the Proposed Action. The pipeline would go to Endicott instead of the shore and would be in close proximity to the Boulder Patch (Figure 2.2.5-1). Sediment from pipeline trenching would be produced closer to, or even in the Boulder Patch, which increases the amount of habitat disturbance to impact the resource. This may increase the amount of habitat disturbance to impact the resource, and would result in a more wide-spread effect than the Proposed Action. The footprint of the proposed LDPI would decrease, which would affect the area vulnerable to crushing and smothering, and could slightly decrease the size of the sediment plume from the LDPI. However, the size of the trench needed to contain a multi-phase pipeline could increase the impacts as compared to the Proposed Action. The types of impacts expected would remain the same, and the change in effects would not change the overall impact designation on lower trophic organisms outside of the Boulder Patch. However, the Boulder Patch impacts would likely be long-term and widespread.

Alternative 4B: Relocate Oil and Gas Processing to a New Onshore Facility

Potential impacts on lower trophic organisms and the Boulder Patch under Alternative 4B would be similar to those described for the Proposed Action. The footprint of the proposed LDPI would decrease, which would affect the area vulnerable to crushing and smothering, and could slightly decrease the size of the sediment plume. This onshore production facility would have negligible impact to marine, nearshore, and Boulder Patch resources, as it would be located entirely on land. In general, the types of impacts on lower trophic organisms and the Boulder Patch would remain the same or be reduced slightly in magnitude. The overall impact designation would not change.

Conclusion

Conclusion for Alternative 4A: Impacts of Alternative 4A on lower trophic organisms outside of the Boulder Patch would be essentially the same as those for the Proposed Action: minor for routine activities, minor to moderate for small spills, and moderate for a large spill. Impacts of Alternative 4A on the Boulder Patch would differ from impacts for the Proposed Action: major for routine activities, moderate for small spills, and major for a large spill.

Conclusion for Alternative 4B: Impacts of Alternative 4B on lower trophic organisms would be essentially the same as those for the Proposed Action: minor for routine activities, minor to moderate for small spills, and moderate for a large spill. Impacts of Alternative 3A on the Boulder Patch may be smaller than the impacts for the Proposed Action: minor to moderate for routine activities, moderate for small spills, and major for a large spill.

4.3.1.5. Alternative 5 (Alternate Gravel Sources)

Potential impacts on lower trophic organisms and the Boulder Patch under Alternative 5 would be similar to those described for the Proposed Action. Although the location of the gravel mine would change, the types of impacts would remain the same and would not change the overall impact designation on marine lower trophics organisms or the Boulder Patch community.

Conclusion

Impacts of Alternative 5 on lower trophic organisms outside of the Boulder Patch would be essentially the same as those for the Proposed Action: minor for routine activities, minor to moderate for small spills, and moderate for a large spill. Impacts of Alternative 5 on the Boulder Patch would be essentially the same as those for the Proposed Action: moderate for routine activities, moderate for small spills, and major for a large spill.

4.3.2. Fish

4.3.2.1. The Proposed Action

Development

In the marine and estuarine environment, habitat alteration and seafloor disturbance would occur during development of the Proposed Action. Creation of the LDPI and pipeline trenching would affect benthic and pelagic fish species. Noise impacts are expected to occur during development of the LDPI as a result of proposed LDPI armoring activities, vessel traffic, gravel deposition, and pipeline laying. During construction at the LDPI, there would be no discharges of sanitary and domestic wastewater, potable water treatment reject wastewater, or STP wastewater. HAK anticipates discharging construction dewatering and secondary containment dewatering intermittently during construction activities. In the freshwater environment, anadromous fish present in the area of the gravel mine may be impacted by noise as a result of mining activities. Construction of ice roads may impact freshwater fish through water withdrawals from lakes, mines, or ponds.

Production

Production activities in the Proposed Action would take place on the LDPI, in the marine environment, and onshore. Habitat alteration is generally not expected to occur during production, as production activities are based on the proposed LDPI and do not require changes to the seafloor. Noise impacts would still be present from sources such as maintenance geohazard surveys of the pipeline, and vessel traffic. Physical presence of the LDPI may affect benthic and pelagic species present in the nearshore Beaufort Sea. Water intake structures could affect small marine pelagic fish, larvae, and eggs (impacts are discussed in Section 4.2.1.1). Freshwater fish may be impacted by water withdrawals for ice road construction. As discussed in Section 3.2.2, the current fish community may be altered by climate change processes, and though the impacts may intensify, they are not expected to differ from those described below.

Decommissioning

The removal of the LDPI would result in habitat alterations. The subsea pipeline would be flushed of all contaminants, ends cut and sealed, and abandoned in place, and decommissioning activities associated with it are not expected to impact fish. Onshore decommissioning activities may impact

freshwater fish by creation of overwintering and freshwater habitat. Mine rehabilitation may provide habitat for freshwater and anadromous fish.

Habitat Alteration

Gravel deposition during LDPI creation would alter the seafloor habitat and could crush benthic fish species, resulting in injury or mortality to individual fish present in the 24-acre footprint. Pipeline trenching and potential maintenance activities on the trenched backfill would also disturb the seafloor and would disturb habitat for benthic species. Fish are mobile animals and are expected to leave the area of disturbance, which would decrease the number of individuals that are affected by gravel placement and pipeline laying. Removal of the armor plating on the LDPI during decommissioning would result in complete removal of habitat for any species that had colonized the LDPI during the production life of the Proposed Action. As a result of gravel deposition, adult and juvenile fish are expected to exhibit avoidance behaviors in relation to construction activities, which would decrease the number of individuals that could be injured or killed by LDPI creation. Avoidance behavior would likely cease shortly after the disturbance was completed. The habitat available in the area of the LDPI would be different from the rest of Stefansson Sound, but may still be usable to some fish species. Fish eggs and larvae are generally unable to exhibit avoidance behaviors. Any fish eggs or larvae present during construction activities would likely be killed or injured. Gravel deposition is expected to be a short term activity and limited to the footprint of the LDPI and pipeline, although the proposed LDPI can be considered a long-term alteration to the overall habitat to Stefansson Sound.

Gravel deposition and pipeline trenching is expected to increase turbidity temporarily as sediments on the seafloor are suspended in the water column. Localized increases in turbidity and a turbidity plume are expected around the proposed LDPI and pipeline path. The plume is expected to move offshore, away from the Sagavanirktok River (Figure 4.2.2-1); (Coastal Frontiers Corporation, 2014). This could affect marine benthic and pelagic species by decreasing visibility, which impacts both predator and prey interactions (De Robertis et. al., 2003), and also by potentially clogging gills. In the ice-covered season when construction activities are mostly occurring, the sediment plume is expected to be limited by the low currents and ice bonding of silt (Toimil and England, 1982; Newbury, 1983). Currents during the open-water season are higher due to greater impacts from winds (Trefry, et al., 2009), and so the area affected by elevated turbidity would increase. Monitoring of turbidity from previous gravel island constructions in the Beaufort Sea showed increased turbidity around installations during the summer, but detection of increased suspended sediments was unlikely beyond 500 meters (m) from the site (Coastal Frontiers, 2014). Turbidity is likely to return to ambient levels once construction activities are completed; for the majority of the life of the project, local turbidity would not be increased. During the production phase, localized turbidity would likely be increased above ambient levels as a result of TSS concentrations in the ongoing STP discharge. However, any elevated TSS or turbidity is expected to quickly disperse to background levels by local currents and tides. Decommissioning activities are expected to increase the turbidity through resuspension of sediments as the proposed LDPI is worn away by currents. Impacts on fish from changes in turbidity are expected to be short term and localized.

Ice habitat would be affected by cutting excisions in the ice to allow for gravel deposition. This could impact the feeding habitat of ice-associated fish species, such as Arctic cod (Lonne and Gullikson, 1989; Gradinger and Bluhm, 2004) by removing and eliminating ice ridges where these fish feed, though there is a large area of other available ice habitat.

Construction of ice roads may impact some freshwater fish habitat by altering the environment of the ponds, lakes, or abandoned gravel mines. Use of ice roads would take place outside of the aquatic environment, and would have negligible impact on fish resources. Cott et al. (2008) analyzed the effects of water withdrawal from ice covered lakes on fish and found that impacts vary depending on the individual lake. However, some lakes showed decreases in overwintering habitat and oxygen

levels. The impacts of water withdrawal as part of the Proposed Action may have localized adverse impacts to fish resources, should they be present in lakes used for this purpose, but the number of lakes or ponds impacted is relatively small compared to the amount of tundra lake habitat available in the region. Impacts in individual lakes may last longer than a year. Eventually, lakes would be expected to be recolonized by common fish species through flooding events. Reuse of the same pond for water each year would decrease the number of ponds affected for the life of the project. The effects of water withdrawal for ice road construction would be localized and less than severe.

The gravel mine, if located where fish are present in the surrounding waterbodies, may impact some overwintering freshwater and anadromous species, such as humpback and broad whitefish, ciscos, suckers, Dolly Varden, and sticklebacks through mining activities. Disturbances could include habitat degradation. If the mine site is rehabilitated in such a way that flooding could introduce fish species, these species may benefit from habitat expansion at this location.

Marine fish species (considering all life stages) that would be most affected by habitat alteration in the Proposed Action include: capelin, , Arctic cod, saffron cod, starry flounder, Alaska plaice, and Bering flounder , Arctic alligatorfish, and Pacific sand lance. Estuarine, migratory, and anadromous species (considering all life stages) that would be most affected nearshore and in tidal riverine areas include: capelin, least cisco, Bering cisco, broad whitefish, humpback whitefish, Arctic cod, saffron cod, Arctic char, dolly varden, pink salmon, chum salmon, and ninespine stickleback.

Summary of habitat alteration impacts

The initial construction of the LDPI would have the most adverse impact on fishes through habitat alteration. These impacts are not expected to have a population level effect, as adult and juvenile fish are mobile and are expected to avoid the area during construction activities, thus decreasing the number of individuals that are impacted by crushing, smothering, or increased turbidity. Once the proposed LDPI is in place and construction activities are over, fish are expected to return eventually to normal use of the area. The proposed LDPI itself may mitigate adverse impacts by providing habitat for species that prefer hard-bottom substrates. Although the general habitat alteration impacts are expected to be relatively long-term, they would be less than severe and extremely localized to the proposed LDPI and gravel mine sites.

Noise

Fish rely heavily on sensory perceptions of sound and pressure for many activities vital for survival, such as feeding, navigation, spatial orientation, predator avoidance, and communication. Hearing loss can occur in fish from continuous (i.e., drilling) or impulsive sound (i.e., pile driving, seismic surveys) (Halvorsen et. al., 2012). Injury to the auditory nerve, hair cells, or swim bladder can be temporary or permanent. There could be chronic behavioral and physiological effects to fish at less intense sounds, and acute effects for individuals within a few meters of a sound source. If recovery from physical injury is slow or does not occur, fitness would be reduced and individuals would be more susceptible to physiological dysfunction, disease, and predation. Behavioral impacts may occur, including: balance disturbance; disoriented swimming behavior; increased swimming speed; disruption or tightening of schools; disruption of hearing; interruption of important biological behaviors (e.g., feeding, reproduction); shifts in the vertical distribution; and occurrence of alarm and startle behaviors (Dalen and Knutsen, 1987; McCauley, Fewtrell, and Popper, 2003; Pearson, Skalski, and Malme, 1992; Turnpenny, Nedwell, and Thatcher, 1994). Gravel mining and trucking of materials on ice produce enough sound to cause avoidance behaviors in sensitive-hearing fish species near ice roads and in Arctic lakes (Stewart, 2003; Mann, Cott, and Horne, 2009). Noise generated by geohazard seismic surveys could affect fish through several pathways, including interference with sensory orientation and navigation, decreased feeding efficiency, disorientation, scattering of fish away from a food source, and redistribution of fish schools and shoals (Purser and Radford, 2011; Slabbekoorn et al., 2010).

During construction and production, a potential stationary zone of displacement would likely be created around the LDPI by noise-related avoidance behaviors. In the short term, these sounds may frighten, annoy, or distract a fish and lead to physiological and behavioral disturbances, which in turn can lead to reduced fitness of individual fish. Over the long term, this impact could be naturally mitigated by habituation of fish to the noise produced by the drilling activity. Because drilling noises would be somewhat regular in type and source, it is possible that some fish species may become habituated to them and the zone of displacement may be reduced over time. Geohazard surveys to maintain the pipeline may cause damages to fish and fish larvae that are close to the noise source (Halvorsen et. al., 2012; Hawkins and Popper, 2012). However, it is expected that fish would exhibit immediate avoidance behaviors and these geohazard surveys would be infrequent, which would decrease the number of individuals affected. Mining activities, use of ice roads, and sea ice excision may elicit startle responses or avoidance behaviors in freshwater and estuarine fish. Vessel traffic may result in noise-related impacts, such as startle or avoidance behaviors, as described above.

The noises produced by the Proposed Action could affect fish, causing them to leave the source location or adjacent area. Some fishes are of greater concern, due to their distribution, abundance, trophic relationships, or vulnerability in relation to noise and seismic emissions: (1) migratory fishes that are abundant seasonally in the nearshore zone that could be deterred or obstructed in reaching their reproductive feeding grounds, especially Arctic char, least cisco, and broad whitefish; (2) fishes known to be particularly important in the trophic food web, including Arctic cod, and (3) Pacific salmon in their marine and estuarine migration and staging periods of life due to their broad distribution and exposure to sound over their entire life cycles.

Migratory species at risk of spawning delays or disruptions include Pacific salmon (mainly pink and chum salmon), cisco, and broad whitefish. Arctic cod and sculpins are hearing specialists and are some of the most acoustically sensitive species occurring in the area. They are, therefore, some of the most likely fishes to exhibit displacement and avoidance behaviors due to noise and seismic activities.

Estuarine and freshwater fish would be affected by vessel and construction noise, and could include species such as: least cisco, Bering cisco, broad whitefish, humpback whitefish, Arctic cod, Arctic char, dolly varden, pink salmon, chum salmon, ninespine stickleback, Arctic flounder, and capelin.

Summary of Noise Effects: Noise related impacts are expected to occur during development, production, and decommissioning phases. Physical and behavioral effects on fish and fish prey may occur as a result of construction, drilling, and ancillary activities, including geohazard seismic surveys. Construction activities and eventual removal of the armor plating of the LDPI would result in noise impacts. Vessel traffic, including use of ice roads, would produce noise that may affect fish in the area. These impacts are not expected to have a population level effect, as adult and juvenile fish are mobile and are expected to avoid the louder, infrequent sounds and to attenuate to the constant (i.e., drilling) noises. However, noises present during spawning or migratory periods may have a greater impact on some fish species. In general, sound impacts are expected to be temporary and localized to the proposed LDPI and pipeline.

Physical presence

Numerous vessel roundtrips would occur between the offshore facilities and the onshore facilities in open-water months during the life of the Proposed Action, especially during the development years (See Table 2.1.1-2). Fish species in the coastal and marine environments could be disturbed by the presence and passing of vessels during roundtrips from the proposed LDPI during the open-water season. Vessels cause a path of physical disturbance that could affect the behavior of fish species. Free-swimming fish in the immediate vicinity of such vessels are expected to avoid vessels. Pressure waves from vessel hulls could displace fish and cause injury or mortality to non-swimming and weak swimming fish life stages and fish prey (Hawkins and Popper, 2012). Additionally, one to two barge trips per year may transit through Dutch Harbor, and would occur in areas outside of the region

described in section 3.2.1. Impacts from these limited barge trips to the Beaufort Sea are the same as described in the BOEM Chukchi Sea Planning area Lease Sale 193 Second SEIS (USDOJ, BOEM, 2015).

The proposed LDPI, once constructed, could provide hard substrate habitat for some fish species. Existing information on fish attracting devices indicates that fish species are attracted to offshore structures (Fabi et al., 2004; Franks, 2000) because of the additional hard substrate habitat they provide for invertebrates, and protective habitat for finfish. The LDPI would occupy the entire water column, from the seafloor through the splash zone. The effects of the presence of the proposed LDPI may provide additional sheltering areas for fish or could attract predators (Fujii, 2015). Lights on the proposed LDPI during all phases may attract fish prey and predators (Shaw et al., 2002).

Many public comments raised the concern that the physical presence of the LDPI could also cause obstruction to movement for some fish species. A study on fish movement before and after Endicott showed that the construction of the island and causeways did not cause changes in fish movement (Craig and Griffiths, 1981; Schmidt et al., 1991). Least cisco young-of-the-year are carried into the US Beaufort Sea from the Mackenzie River by winds and wind-driven currents (Schmidt et al. 1991; Gallaway et al., 1983). The proposed LDPI is unlikely to interfere with these movements, as the waves and currents are expected to go around the proposed LDPI, and the proposed LDPI would not prevent movement to and from Stefansson Sound. The presence of the pipeline is expected to have little to no impact on fishes, as it would be buried (marine) and/or stationary (onshore). The impact from physical presence of the LDPI would gradually disappear during decommissioning as the gravel is carried away by currents, but that process would take many seasons. Although the the proposed LDPI is a long-term addition to Stefansson Sound, fish are expected to habituate to it after initial construction has been completed.

EPA's NPDES permit requires HAK to develop and implement a Best Management Practice (BMP) Plan to minimize the entrainment and impingement mortality of fish and shellfish. Specifically, the NPDES permit requires HAK to "select and implement seawater intake structure design and construction technologies or operational measures for minimizing entrainment and impingement mortality of fish and shellfish." This requirement is consistent with the Cooling Water Intake Regulations found at 40 CFR Part 125.84(c)(4), which regulates cooling water intake facilities with design flows greater than 2 MGD. Although the proposed STP facility would not be designed for cooling purposes, it would withdraw approximately 4.4 MGD, and, without proper design controls, could have the potential to cause entrainment and impingement mortalities. Compliance with these NPDES permitting requirements would minimize the effect of water intake structures on all life stages of fish and shellfish, and plankton.

The wastewater discharges associated with the LDPI consist of conventional pollutants, which are designated under Section 304(a)(4) of the CWA as BOD, TSS, pH, fecal coliform, and oil and grease. These conventional pollutants are not expected to bioaccumulate or persist in the environment. With the exception of the ongoing discharges from the STP during the life of the project, all other authorized discharges would be temporary, short-term, and would produce negligible impacts.

Pollutants not classified as conventional or toxic, such as temperature, are considered to be "nonconventional." The potable water treatment (Outfall 001B) and the STP (Outfall 002) processes may result in elevated temperatures in the effluent, as compared to the ambient receiving waterbody conditions. To ensure those discharges would not result in an unreasonable degradation of the marine environment, the NPDES permit requires weekly temperature monitoring of the influent and effluent for those systems.

Additionally, wastewater discharges from the potable water treatment system and the STP may contain trace amounts of chemicals. HAK has indicated that both systems may require the use of maintenance chemicals, such as biocides, clarifying agents, descalers, and/or

chlorination/dechlorination chemicals. The STP has been designed to minimize the release of these chemicals to the environment and the potable water treatment reject wastewater is expected to be disposed of through the disposal well. However, the NPDES permit requires whole effluent toxicity testing semi-annually and quarterly on effluent samples from the potable water treatment reject wastewater and the STP, respectively, during periods when chemicals are used and when the applicable waste streams are discharged to surface waters. It is expected that the discharged water would rapidly dilute, mixing to background levels. Effects of water intake and discharge would be localized to the LDPI and are not expected to have population-level impacts. Impacts to the Boulder Patch from water intake and discharges are expected to be negligible. Marine fish species (considering all life stages) that would be most affected by the physical presence of components of the Proposed Action offshore include: capelin, least cisco, Bering cisco, broad whitefish, humpback whitefish, Arctic cod, saffron cod, Arctic char, dolly varden, pink salmon, chum salmon, ninespine stickleback, Arctic alligatorfish, and Pacific sand lance. Estuarine, migratory, and anadromous species (considering all life stages) that would be most affected nearshore and in tidal riverine areas include: capelin, least cisco, Bering cisco, broad whitefish, humpback whitefish, Arctic cod, saffron cod, Arctic char, dolly varden, pink salmon, chum salmon, ninespine stickleback, starry flounder, Alaska plaice, and Bering flounder.

Summary of physical presence impacts

Fish would be affected by the physical presence of vessels, the LDPI, and pipelines in the marine and coastal environments. The LDPI may affect the movements of individual fish and larvae. The physical presence of ice roads used for winter construction activities is not expected to impact marine, estuarine, or freshwater fish resources, aside from noise, as fish would be located in overwintering locations and not on the direct path of the ice road. Habitat alteration impacts from the presence of the LDPI would span at least three decades, while habitat alteration from the pipeline would not last quite as long. Additionally, the NPDES-permitted waste streams are expected to result in negligible to minor impacts to fishes through habitat alteration. General impacts of the LDPI presence are expected to be temporary and localized.

Oil Spills

Accidental events could include small (<1,000 bbl) and large (\geq 1,000 bbl) spills stemming from the LDPI or the pipeline. Accidental discharge of oil can occur during development, production or decommissioning. Small and large oil spills are considered accidental events, and the Clean Water Act (CWA) and Oil Pollution Act include regulatory and liability provisions designed to reduce damage to natural resources from oil spills.

Small Oil Spills (<1,000 bbl)

Many factors determine the degree of damage from a spill on fish, including the size and duration of the spill, geographic location of the spill, and season. In whatever quantities, accidental oil spills can affect fish and their habitats. For much of the year, Stefansson Sound is covered in first year ice. Small spills are expected to be contained on either the LDPI or landfast ice. Clean up of oil spills before they enter the water column would mitigate the impacts of oil spills on fish. In open-water conditions, where the oil may reach the water column, small spills tend to degrade within the first few days in the marine environment, although a small proportion of the heavier fuel components could adhere to particulate matter in the upper portion of the water column and sink. Spills <1,000 bbl could still have some localized adverse effects to fish. Adverse effects to fish species could be compounded for a spill 200-1,000 bbl (though only one spill 200-1,000 bbl is assumed for this analysis). Toxic effects on fish (particularly early life stages) could occur in the immediate area of a spill. Even at low concentrations that are not directly lethal, some contaminants in oil can cause sublethal effects on sensory systems, growth, and behavior of fish, or may be bioaccumulated. A pipeline rupture over

land could impact freshwater and anadromous fish resources, depending on where the rupture occurred.

Small spills may adversely affect individual fish prey organisms. It is likely that individuals (e.g., prey organisms, eggs, larvae) encountering oil, even at low concentrations, could suffer deformities or mortality. Arctic cod, an important keystone fish species in the Arctic, has been shown to have especially high sensitivity to oil pollution when exposed as eggs (Nahrgang et al., 2016). These effects on the food chain could have indirect effects on larger predatory fish by reducing the available prey base and foraging opportunities for predators.

Chronic small oil spills could have an adverse effect on fish because residual oil can build up in sediments and affect living marine resources. Low levels of PAHs from chronic pollution can accumulate in salmon tissues and cause lethal and sublethal effects, particularly at the embryo stage. Effects on fish from low-level chronic exposure may increase embryo mortality, reduce marine growth (Heintz et al., 2000), or increase straying away from natal streams by returning adults (Wertheimer et al., 2000).

For isolated small spills, which would be short term and localized, minor impacts are expected to pelagic and demersal fish. Although impacts to individual organisms could be lethal, population-level effects would likely not occur for small, isolated accidental spills, especially if they are contained by the LDPI or ice and are cleaned up before they enter the water column. Chronic small spills that enter the water column may have a cumulative effect in the environment, which could lead to multi-generational, long-term effects on fish communities. Over the life of the Proposed Action, the impacts from small spills on fish resources could be moderate. The disturbances and associated adverse impacts on fish from accidental spills may be reduced through the operating procedures required by regulatory agencies. Potential spill impacts would be reduced by incorporation of a spill prevention, control, and countermeasure plan into LDPI operations.

Large Oil Spill ($\geq 1,000$ bbl)

Although unlikely, for purposes of analysis, BOEM assumes that one large spill would occur during the life of the Proposed Action. A large oil spill can occur from many possible sources, including equipment malfunction, pipeline breaks, or human error. Crude oil spills may occur directly from the LDPE or a ruptured pipeline during development and production. A pipeline rupture over land could impact freshwater and anadromous fish resources, depending on where the rupture occurred. Large oil spills could affect marine, estuarine, and tidal riverine fish species depending on the location, volume, and trajectory of the spill and the time of year it occurs. Spilled oil would dilute slowly in ice-covered conditions, and more swiftly in open-water conditions. Local spill trajectory would depend on tide stage as well as wind and wave direction. In the unlikely event that a large oil spill occurred, the spill and the response would affect fish populations.

Although oil is toxic to fish at high concentrations, certain species are more sensitive than others, and oil can have toxic effects even in low concentrations. Pelagic and demersal fish adults, juveniles, eggs, and larvae would be exposed, and there could be acute effects on these various life stages for the fish species in the area. In general, the early life stages of fish (eggs and larvae) are most sensitive, juveniles are less sensitive, and adults least so (Rice et al., 2000). Accidental spills into the water column could cause a direct adverse impact on water quality as well as adverse impacts on pelagic fish and larvae. Strong-swimming demersal and pelagic fish that are exposed to oil spills in the upper water column may be capable of swimming away from oil slicks. Eggs, larvae, and juvenile stages of fish in the water column would have continued exposure to oil due to their inability or limited ability for motility.

Migratory fish, such as whitefish and Pacific salmon, could be affected adversely by a large oil spill in spawning and rearing habitats. Other biologically important fish in the area that could be impacted

by oil spills include Arctic cod, capelin, sculpins, sticklebacks, and snailfish (Morrow, 1980; Jarvela and Thorsteinson, 1999; Craig, 1984). Effects of oil spills in nearshore intertidal areas could persist for generations and might have multiple effects by affecting more than one life stage. The overall effects of individual small spills on fish would be somewhat contained within Foggy Island Bay because of the barrier islands.

The LDPI and pipeline are located within barrier islands, so even though large spills are unlikely, if they occur, the likelihood of contact with part of the shoreline is relatively high. The effects of oil spills, as described previously, could include the mortality of adult and juvenile fish as well as lethal and sublethal effects to eggs and the juvenile stages of fish.

Table 4.3.2-1. Chance of a Large Spill on Liberty LDPI or Pipeline Contacting a Given ERA or LS.

ID	Environmental Resource Area or Land Segment Name	1 day LI	1 day PL	3 days LI	3 days PL	10 days LI	10 days PL	30 days LI	30 days PL	90 days LI	90 days PL	360 days LI	360 days PL
ERA 85	Sagavanirktok River Delta (Annual)	38	39	55	49	61	54	62	54	63	54	63	54
ERA 85	Sagavanirktok River Delta (Winter)	37	38	53	47	59	52	61	53	61	53	61	53
ERA 88	Simpson Lagoon (Annual)	<0.5	<0.5	<0.5	<0.5	3	1	5	2	6	3	6	3
ERA 88	Simpson Lagoon (Winter)	<0.5	<0.5	<0.5	<0.5	4	1	5	2	6	2	6	2
LS 104	Prudhoe Bay, Heald Pt. (Annual)	1	<0.5	3	1	4	2	5	2	5	2	5	2
LS 104	Prudhoe Bay, Heald Pt. (Summer)	1	<0.5	3	1	5	2	5	2	5	2	5	2
LS 105	Point Brower, Sagavanirktok R., Duck I. (Annual)	14	13	24	19	28	21	29	21	29	22	29	22
LS 105	Point Brower, Sagavanirktok R., Duck I. (Summer)	17	15	27	21	32	24	33	24	33	24	33	24
LS 105	Point Brower, Sagavanirktok R., Duck I. (Winter)	14	13	23	18	27	20	28	21	28	21	28	21
LS 106	Foggy Island Bay, Kadleroshilik R. (Annual)	6	37	17	47	21	50	21	50	21	50	21	50
LS 106	Foggy Island Bay, Kadleroshilik R. (Summer)	6	37	17	48	20	49	20	49	20	49	20	49
LS 106	Foggy Island Bay, Kadleroshilik R. (Winter)	6	36	17	47	21	50	22	50	22	50	22	50
LS 107	Tigvariak Island, Shaviovik R. (Annual)	1	1	5	4	7	5	7	6	7	6	7	6
LS 107	Tigvariak Island, Shaviovik R. (Summer)	1	1	4	3	5	4	5	4	5	4	5	4
LS 107	Tigvariak Island, Shaviovik R. (Winter)	1	1	5	4	7	6	8	6	8	6	8	6

Marine and anadromous fish in Stefansson Sound and the surrounding region are represented in the OSRA model by ERAs and LSs that were identified as important habitat (Table A.1-12); however, only ERA 85 (Sagavanirktok River Delta), ERA 88 (Simpson Lagoon), LS 104 (Prudhoe Bay, Heald Point), LS 105 (Point Brower, Sagavanirktok River., Duck Island), LS 106 (Foggy Island Bay, Kadleroshilik River), and LS 107 (Tigvariak Island, Shaviovik River) had any contact probabilities $\geq 5\%$. All others had contact probabilities $< 5\%$ and so would not be analyzed further. ERA 88, LS 104, and LS 107 and 101 has some instances where the probabilities of contact from a spill would be $\geq 5\%$. Table 4.3.2-1 shows conditional probabilities of contact from a large spill in summer and winter, and the annual probability of contact. The Sagavanirktok River (ERA 85) has the highest chance of being contacted by a large spill that occurs during summer and winter months, with contact probabilities ranging from 37-63% based on the number of days spill constituents are permitted to persist in the environment and whether the spill originated at the LDPI (LI) or the offshore portion of the proposed pipeline (PL). Contact probabilities ranged up to 33% for LS 105 and 50% for LS 106, with the highest probabilities occurring after more time had lapsed. Contact probabilities for ERA 88, LS 104, and LS 107 were generally less than 10% regardless of season.

Large oil spills would be expected to persist on the water long enough (30 days) for a trajectory analysis to predict the fate and distribution of oil. Some of the spilled oil would degrade and weather naturally, but much of it could contact sensitive biological areas. A large oil spill in Stefansson Sound would adversely affect fish resources, and associated habitat by causing lethal and sublethal effects.

Intertidal habitats are most likely to suffer long-term impacts if a large oil spill were to occur. Oiled intertidal areas could lead to considerable mortality of eggs and juvenile stages in the affected areas. Elevated levels of developmental malformations and physiological aberrations in eggs and juvenile stages can cause reduced survival to adulthood, thereby delaying recovery of subpopulations affected by an oil spill. Organisms that rely most heavily on these environments would be most affected. In intertidal areas, some of the species and life stages that might be most affected capelin eggs and adults, sculpins, salmonids, and sticklebacks. A large spill would primarily affect beach and intertidal habitat because it would persist in those areas, possibly for more than a decade.

Depending on the timing of the spill, Arctic cod and whitefish species could be the most impacted, although any marine or estuarine fish species present in the spill region could be affected. A large oil spill during a spawning run could interrupt some spawners, or even substantially reduce a cohort. A large spill during the wind-driven migration of whitefish larvae could greatly reduce recruitment for that year. Recovery of specific cohorts could take years, but is unlikely to cause population-level change in the Beaufort Sea. Depending on the location of the spill, adverse effects on fish resources from oil spills would possibly be of long duration, but likely be less than severe in magnitude because Stefansson Sound fish communities are similar to what is found throughout the nearshore Beaufort Sea, and severe population effects are not expected. Consequently, the overall effects of a large spill would result in moderate impacts on fish resources.

Spill Response Activities

Spill response activities could include mechanical recovery methods and in-situ burning of spilled materials. Increased vessel traffic and corresponding increases in vessel discharges and noise would also be associated with spill cleanup operations. If clean-up operations include sections of the beach, or intertidal zones, access to spawning or overwintering habitat for some species may be restricted.

Pelagic fishes may be affected by mechanical recovery of spilled material, but are expected to avoid an oiled area and to move away from vessels and booms or skimmers. However, these avoidance impacts would be short-term and localized to the spill area. Benthic fishes and shellfish would not likely be affected by mechanical recovery activities occurring at the surface. The effects of mechanical recovery on fish resources would be negligible.

In-situ burning of spilled oil is used to remove oil from the surface and may impact fish in the immediate burn area during the burn. As with lower trophic organisms, residue from a burn can sink and smother benthic fish. These effects are expected to be short-term and localized to the immediate burn area.

Spill impacts and cleanup operations would be influenced by time of year. An oil spill occurring into ice may persist for a longer period of time than during ice-free conditions (Buist et al., 2008; Payne, McNabb, and Clayton, 1991). Under calm conditions and cold temperatures in restricted waters, vertical mixing and dissolution would be reduced (Buist et al., 2008). A large spill occurring on or under ice would be trapped and persist until the ice melted, allowing the spill to disperse (Drozdowski et al., 2011), and trapped oil can be transported by currents to areas more distant from the site of the accidental spill. Volatile components of the spill would be more likely to freeze into the ice rather than evaporate. Response efforts would be hindered and aided by the presence of ice. Ice would contain a spill (reduce spreading), concentrate it, and may act as a barrier to shoreline oiling. However, ice also would make a spill difficult to detect, locate, and access. Natural processes would aid the degradation of the oil and gas released during a large spill, but at a slower rate than in warmer waters. Increased vessel traffic would add noise to the environment, and would increase the chance of small discharges from response vessels. Effects to fish from small spill cleanup would be short-term.

Cleanup for a large spill could result in long-lasting and widespread impacts for fish. Effects are unlikely to be population-level, though, as fish can avoid areas of spilled oil. Depending on the size of

the spill and the time of year, oil spills and spill response activities could have minor (small spill) to moderate (large spill) effects on fish.

Conclusion

Overall, the impacts to fish from routine activities associated with the Proposed Action, which includes small, isolated spills, would be short-term and localized, and thus minor. While the presence of the LDPI itself would be long-term, impacts would be minor and would have little to no negative impacts on fish, and would eventually be eliminated. Impacts from small isolated spills would also be minor but could range up to moderate for chronic small spills originating from the LDPI. In the event of a large spill, impacts to fish are expected to be moderate.

Mitigation

The Proposed Action includes several design features in LDPI design, construction, and operation to minimize potential impact to the Stefansson Sound fish community. Appendix C describes mitigation measures derived from lease stipulations, notices to lessees, design features, and operator committed BMPs. These include measures that minimize impacts to the oceanography and water quality including: proposed LDPI and pipeline location to avoid impact to habitat and alteration of ocean currents; LDPI design to minimize size and footprint, decreasing impacts to fish habitat; seawater intake structures designed to prevent fish entrainment; LDPI armoring to reduce erosion and the spread of silt or gravel over fish habitat; and winter construction with fewer fish species present and low water currents, which reduce TSS distribution. These measures were included in this analysis as part of the Proposed Action. No additional mitigation measures to further reduce impacts to fish are proposed in this DEIS.

4.3.2.2. Alternative 2 (No Action)

Under Alternative 2, the Proposed Action would not occur, and the impacts to fish in Stefansson Sound described above would not occur.

4.3.2.3. Alternative 3 (Alternate locations for proposed LDPI)

Alternative 3A: Relocate LDPI Approximately One Mile to the East

Potential impacts on fish under Alternative 3A would be similar to those described for the Proposed Action. The footprint of the proposed LDPI would increase and the pipeline would be longer, which would affect the area vulnerable to crushing and smothering, and could slightly increase the size of the sediment plume. More gravel would be needed to construct the LDPI, which could increase impacts on freshwater fish. However, the types of impacts would remain the same, and the increase in effects would not change the overall impact designation on fish.

Alternative 3B: Relocate LDPI Approximately 1.5 Miles to the Southwest

Potential impacts under Alternative 3B would be similar to those described for the Proposed Action. However, the footprint of the proposed LDPI would decrease and the pipeline would be shorter, which would affect the area vulnerable to crushing and smothering, and could slightly decrease the size of the sediment plume. The marine and nearshore fish species impacted would remain the same. However, the general types of impacts would remain the same, and the decrease in effects would not change the overall impact designation on fish.

Conclusion

Conclusion for Alternative 3A: Impacts of Alternative 3A on fish would be essentially the same as those for the Proposed Action: minor for routine activities, minor to moderate for small spills, and moderate for a large spill.

Conclusion for Alternative 3B: Impacts of Alternative 3B on fish would be essentially the same as those for the Proposed Action: minor for routine activities, minor to moderate for small spills, and moderate for a large spill.

4.3.2.4. Alternative 4 (Alternate Processing Locations)

Alternative 4A: Relocate Oil and Gas Processing to Endicott

Potential impacts on fish under Alternative 4A would be similar to those described for the Proposed Action. The pipeline would go to Endicott instead of the shore, and would be in close proximity to the Boulder Patch. Sediment from pipeline trenching would be produced closer to, or even in, the Boulder Patch. This may increase the amount of habitat disturbance impact to fish that use the resource. Impacts to nearshore fish may be decreased if the pipeline is not routed through the nearshore environment. The footprint of the proposed LDPI would decrease and less gravel would be required, which would affect the area vulnerable to crushing and smothering, and could slightly decrease the size of the sediment plume. However, the types of impacts expected would remain the same, and the change in effects would not change the overall impact designation on fish.

Alternative 4B: Relocate Oil and Gas Processing to a New Onshore Facility

Potential impacts to fish under Alternative 4B would be similar to those described for the Proposed Action. The footprint of the proposed LDPI would decrease, which would affect the area vulnerable to crushing and smothering, and could slightly decrease the size of the sediment plume. Less gravel would be needed to construct the LDPI, but additional gravel would be required for construction of the production pad onshore. This onshore production facility could affect nearshore and freshwater fish during construction activities, if any streams or lakes were located in close proximity to the pad. In general, the types of impacts on marine, anadromous, and freshwater fish species would remain the same, and the change in effects would not change the overall impact designation.

Conclusion

Conclusion for Alternative 4A: Impacts of Alternative 4A on fish would be essentially the same as those for the Proposed Action: minor for routine activities, minor to moderate for small spills, and moderate for a large spill.

Conclusion for Alternative 4B: Impacts of Alternative 4B on fish would be essentially the same as those for the Proposed Action: minor for routine activities, minor to moderate for small spills, and moderate for a large spill.

4.3.2.5. Alternative 5 (Alternate Gravel Sources)

Potential impacts on fish under Alternative 5 would be similar to those described for the Proposed Action. Changes in gravel mine location could affect different streams, but the general species affected would be the same. Although the location of the gravel mine would change, the types of impacts would remain the same and would not change the overall impact designation on fish.

Conclusion

Impacts of Alternative 5 on fish would be essentially the same as those for the Proposed Action: minor for routine activities, minor to moderate for small spills, and moderate for a large spill.

4.3.3. Birds

This section analyzes the potential effects of the Proposed Action and alternatives on birds in marine, coastal/intertidal and terrestrial environments, including those species listed as threatened or endangered under the Endangered Species Act (ESA). Effects to birds that are expected to occur within the specific context of the Proposed Action and Alternatives are analyzed, without and with mitigation, so that potential levels of impact can be determined.

4.3.3.1. The Proposed Action

Potential impacts to birds from the Proposed Action are summarized in Table 4.3.3-1 and detailed below. Impacts are described in terms of a relative impact along a continuum. Localized impacts are less than those that are widespread. Temporary impacts are less than those that last for several seasons or decades, depending on species context. Activities that result in mortalities may affect relatively few individuals of a population (less than severe) or could affect so many that the population would take many years to recover (severe). Effects with no detectable mortality, are localized, or temporary, are generally negligible to minor. Wide-spread, long-term (decades) effects resulting in mortality that would not be recovered for an extended period are considered major impacts.

Bird species most likely to be affected by the Proposed Action include species that are chronically susceptible to collisions during migration, vulnerable to increased predation levels in nesting areas, and/or repeated disturbance in foraging, nesting, and molting areas (e.g., some sea duck, loon, passerine, and shorebird species), particularly those with small and/or potentially vulnerable populations (e.g., eiders, brant, red-throated loon, buff-breasted sandpiper dunlin, phalaropes, and other shorebirds).

Table 4.3.3-1. Summary of Impacts to Birds by Impact Producing Factor.

ESA Status	Disturbance Vessel Traffic	Disturbance Aircraft Traffic	Disturbance Vehicle (Road) Traffic	Habitat Alteration Terrestrial Construction / Alteration	Habitat Alteration Marine Construction / Alteration	Physical Presence, incl. Lights	Increased Predation	Small Oil Spills	Large Spill
Level of Impact: Non-Listed Species	Minor	Moderate	Minor	Minor	Minor	Minor	Minor to Moderate	Negligible to Minor	Major
Level of Impact: Listed Species	Minor	Minor	Minor	Minor	Minor	Minor to Moderate	Minor	Negligible to Minor	Moderate

Disturbance and Displacement

Vessel, air, and vehicle traffic can disturb and displace birds. Besides behavioral effects, this can have energetic and productivity consequences. Traffic can also have direct mortality effects on birds. Many of these potential effects are especially pronounced during sensitive stages of birds' annual cycles. This section analyzes potential impacts to birds resulting from Proposed Action aircraft, vessel, and vehicle traffic. Sources of impacts (i.e., traffic sources) are examined separately for all birds in the Proposed Action Area, then for listed species. This is followed by a conclusion of the overall expected level of disturbance impact for the Proposed Action.

Vessel Traffic

Many marine and coastal birds avoid close contact with vessels while swimming in coastal or pelagic waters, or even nesting onshore, and can be temporarily displaced from localized areas when support vessels approach or transit through the area (Burke et al., 2005). Birds may be especially sensitive to vessel disturbance when undergoing flightless molt in sheltered marine waters, or staging, and

foraging pre-migration. Besides disturbance and displacement, birds can collide with lighted vessels under certain environmental conditions, an effect that is discussed separately below (Light Attraction and Collisions).

As described in Chapter 2 (Table 2-1) and the 2015 Liberty DPP (Table 5-3), barges, hovercraft, and other vessels would be used to transport equipment, personnel, and supplies to the LDPI during the open-water season. About 20 vessel trips per day, including shoulder season hovercraft use, would occur for the years of construction and drilling, and generally fewer than 2 or 3 trips per day during the years of operations. Vessels would transit along a marine access route between the LDPI, Endicott SDI, and West Dock (Figure 2.1.1-2), with some deviation occasionally expected by hovercraft “during shoulder seasons when...open-water vessel support (is) not available” (Hilcorp, 2015, Section 5.1.3).

Foraging, resting and molting birds in the water could be disturbed by vessel traffic and noise, particularly in the proposed routes between the proposed LDPI and Endicott SDI and between Endicott SDI and West Dock. Bird species resting in surface waters and foraging in surface waters, the water column and seafloor of the Proposed Action Area could be the most impacted. Long-tailed ducks, common and king eiders, Pacific and red-throated loons, and glaucous gulls are among the most common birds using these waters, and vessels would also regularly encounter others such as scoters (*Melanitta* spp.), mergansers, phalaropes, arctic tern, black-legged kittiwake, and black guillemot. Most birds paddle away from slow-moving vessels or take flight. Birds undergoing flightless molt in marine waters of the Proposed Action Area, such as long-tailed duck, would remain capable of slowly moving away from slow-moving vessels via paddling or diving. Many species, including flight-capable long-tailed ducks, common eiders, and scoters, typically take flight to avoid a fast-approaching vessel; the larger the flock, the greater the distance at which they flush on vessel approach (Kahlert, 2006; Madsen, 1985; Schwemmer, et al., 2011). Regular vessel disturbance of flocks of sea ducks and seabirds is expected. Vessel disturbances and speeds at which species are disturbed would vary, and many birds would return quickly. Some birds, including scoters, king eider, and Kittlitz’s murrelet, however, could be displaced from preferred foraging habitats for 6-8 hours or more (Agness et al., 2008; Gall, 2013; Lacroix et al., 2003; Merkle et al. 2009; Frimer, 1994; Schwemmer, et al., 2011). Aside from temporary disturbance, loons (*Gavia* spp.) apparently change their distribution to avoid high shipping intensity areas (Schwemmer et al., 2011).

Vessel disturbance during brood rearing would have a possible negative impact on chick-provisioning rates of individual Pacific and red-throated loons and other piscivorous waterbirds that breed in or near the Proposed Action Area, based on studies of piscivorous murrelets in southeast Alaska (Hentze et al., 2006 ; Schoen et al., 2013). Because loons and other piscivores do not forage locally in high density flocks they are unlikely to be disturbed in large numbers, and disturbance effects would be minimal.

The largest concentrations of molting waterfowl along the central Beaufort Sea coast occur on the lagoon side of barrier islands, but this is variable according to species and time of day. Brood-rearing waterfowl including brant also use nearshore waters inside the lagoons. Project vessels would regularly transit through nearshore waters inside of the outermost barrier islands (e.g., Cross Island, Narwhal Island), but not generally within narrow lagoon habitat or immediately adjacent to barrier islands. From July-September, which is most of the vessel-use period, open water should be extensive enough that birds and vessels are not restricted to narrow leads and relatively few birds should be disturbed along the proposed vessel routes. The probability of disturbance and displacement of birds by marine traffic could increase during break-up and freeze-up if open-water availability is restricted because potential spatial overlap of birds with marine transit routes is greater.

Vessel disturbances would persist over the life of the Proposed Action across the entire 30 km of nearshore habitat across the Sagavanirktok River Delta. Given the high levels of site fidelity for some

species, it is possible that some of the same individuals would experience repeated vessel disturbance within and between years. Impacts to birds from routine vessel traffic would be limited when the traffic follows the planned route distant from onshore habitat (Hilcorp, 2015, Figure 5-3) since it would not disturb or wake-swamp nesting birds or nests or disturb staging shorebirds. When ice or weather conditions cause vessel routing to deviate, a greater level of impact could result if vessels approach close to important onshore habitat when large flocks of birds are using the habitat, or should large numbers of shorebirds of any one or more particular species be repeatedly displaced during the peak of a migration stopover period. Conditions that would bring vessels in close proximity to deltas, lagoons, saltmarshes, or other important littoral habitats when birds are present would be infrequent, so disturbance and displacement impacts to birds from vessel traffic would be primarily in open-water areas.

Aircraft Traffic

Some marine and coastal birds can be disturbed and/or temporarily displaced from local areas when aircraft transit across coastal and pelagic areas. Disturbance levels often increase with larger flock sizes, and flights are more likely to affect species that are sensitive to noise and aircraft presence or are in a particular area because they are molting, brood-rearing, or resting, or staging. Brant feeding and resting in coastal salt marshes, and molting and post-breeding king eiders and long-tailed ducks have been impacted by local aircraft transits (Mosbech and Boertmann, 1999; Frimer, 1994; Ward and Sharp, 1974). Breeding birds can also be disturbed by aircraft, including eiders by low-level (e.g., <200 m) flights, and gulls and jaegers at potentially higher altitudes (Maftai et al., 2015).

Helicopter traffic (no fixed-wing aircraft use is planned) associated with the Proposed Action would occur year-round (Table 2-1). Up to 2 flights per day would support early construction efforts, followed by up to 4 flights per day during 2 years of overlapped construction and drilling activities (Table 2-1, Figure 2-1). Production activities would be supported by a maximum of 2 flights per day. (In order to be conservative in the following analysis of effects, numbers of flights and years of activities are assumed to be approximate.) Flights are expected to occur among multiple Proposed Action-related sites, including the proposed LDPI, Endicott SDI, West Dock, Deadhorse, and along the proposed onshore and offshore pipeline route. The DPP (Hilcorp, 2015, Section 5.1.4) states that “(t)ypically...routing is direct as possible.” Because it also notes that “routes and altitude (will be) adjusted to accommodate weather, other air traffic, and subsistence activities,” and because of the number and variety of Proposed Action destinations and routes, most flights would route over river deltas and associated barrier island habitat (e.g., Sagavanirktok River Delta).

Aircraft traffic could disturb and displace birds during important life history stages, including breeding, nesting, and pre-migration staging. Most impacts would occur during the open-water season, when birds are most abundant in the area. During the winter months, when ice and snow covers available open-water and terrestrial habitat, most birds are absent. Only raven, ptarmigan, raptors, and owls would occur, in very low abundances (Hilcorp, 2015, Appendix A, p. 2-49) .

Birds that potentially would be impacted by air traffic associated with the Proposed Action are primarily those at breeding colonies or concentration areas, and flocks of staging and migrating shorebirds and waterfowl. Air traffic over the Sagavanirktok River and Kadleroshilik River Deltas could impact birds, depending on flight frequency, environmental conditions, seasonal bird abundance and flock size. If several overflights occurred when large flocks of peak numbers of fall staging shorebirds are present on one of these deltas, hundreds or thousands could potentially experience reduced foraging or resting times leading to reduced fitness. Four overflights occurring at the same tidal phase daily for a week could lead to such effects, but this scenario could occur only during the 2 years of overlapped construction and drilling activities and therefore be considered a short-term, if fairly widespread (given the number of shorebirds and their migratory nature) impact.

Nesting snow geese at the Howe Island colony and brant on the Sagavanirktok River Delta are sensitive to disturbance by aircraft from May to August (Noel, Johnson, Butcher, 2004; Ward et al., 1999), and common eider and some seabirds are particularly sensitive when using barrier island nesting habitat, between May and July (Carney and Sydeman, 1999). The Howe Island colony has been recognized as a sensitive biological resource, as noted by Hilcorp (2015, Appendix A, Section 3.13). Over half of the breeding Sabine's gulls recorded during ACP surveys were located in the Proposed Action Area (Dau and Bollinger, 2009, 2012). The local breeding density of most other sensitive waterbirds are not highly concentrated or large relative to overall ACP populations (Dau and Bollinger, 2009, 2012).

Some raptor species have been reported to habituate to low-altitude helicopter flights and negligible levels of effect on the reproductive success of raptors or passerines from aircraft disturbance is expected (Andersen, Rongstead, and Mytton, 1989; Delaney et al., 1999).

Overall, most aircraft disturbances would be brief. With few great concentrations of nesting birds expected in the Proposed Action Area, few breeding individuals would be subject to repeated disturbance. Exceptions may be the snow goose/brant and Sabine's gull colonies, which host important portions of the Beaufort Sea populations and therefore disturbance, particularly from low-level flights, could cause more long-lasting and widespread effects. Low-level flights over large flocks of staging shorebirds could have a greater level of impact if the same shorebirds are displaced repeatedly. The 2015 Liberty DPP (Section 5.1.4) indicates that flight altitude may be adjusted for operations (i.e., not including mitigation) reasons under certain conditions (see above), but low-level flights that typically cause flock displacement (e.g., <600 ft (Mosbech and Boertmann 1999)) are expected to occur no more than a few times under such conditions during the 2 years of most frequent (i.e., 4 per day) flights. While routes over some of these important nesting and staging habitats are expected, low altitude flights would be irregular and few. In conclusion, given the expected flight rates and availability of open-water habitat for pelagic foraging birds, and infrequent necessity for low-level flights, disturbance and displacement from aircraft traffic would have a minor level of impact on most birds, and no more than a moderate level of impact on a handful of species of geese and gulls.

Vehicle Traffic

Vehicle traffic and heavy equipment operations in terrestrial environments can impact birds with associated noise, human activity, and physical alteration of the environment. Similar to vessel and aircraft traffic effects, vehicle traffic can disturb nesting birds or cause birds using an area for foraging or rest during migration to avoid the area and be displaced to areas of less favorable food resources. The majority of vehicle and heavy equipment operations associated with Proposed Action construction would occur during the winter season and on ice roads when and where most birds are not present, so impacts to birds would be minimized. Construction of the pads and pipeline, and vehicle traffic in winter mainly would displace a few individual adult ptarmigan from the immediate work area or route of ice roads.

Vehicle traffic and heavy equipment operations that continue until areas of surrounding tundra become snow-free or birds arrive on tundra or adjacent intertidal areas could potentially impact birds, particularly early-nesting birds. Tundra ice road footprints can experience delayed ice and snowmelt, and use may be expected until April (Table 2-1). Birds using the areas during courtship may avoid the area or be displaced to less favorable nesting territories. After construction is complete, ice road vehicle traffic disturbance during the operations phase is expected to be negligible relative to the large amount of surrounding adjacent habitat and low densities of breeding birds in the early spring.

Increased ground traffic is expected year-round on the nearby gravel road from Deadhorse to Endicott SDI. Traffic would be higher during construction, but remaining elevated above current levels through the life of the Proposed Action. Any tundra-travel vehicle usage in summer has the potential

to disturb nesting birds or destroy flightless chicks. Increased traffic on the tundra during the spring and summer on Proposed Action Area access roads could impact natural movement patterns of some tundra-nesting birds and their broods. Broods may avoid crossing a road on their way to the safety of aquatic habitat, for example, and experience increased predation when they remain exposed. A vehicle collision that causes the loss of an incubating parent would guarantee the death of an entire brood, or entire broods (including shorebirds and waterfowl such as snow geese and brant) could be struck by one vehicle. Most tundra-nesting birds in this area, however, are not colonial breeders and therefore do not occur in any large concentrations that would put them at more than minor risk of occasional collisions. Exceptions could be black brant and snow geese, which breed in their highest ACP concentrations between the Colville River Delta and the Sagavanirktok River Delta (Larned, Stehn, and Platte, 2010; Stickney and Ritchie, 1996).

A maximum of single-digit vehicle collision numbers have been reported for any bird species in the BPXA North Slope oil fields between 2010-2014 (Bishop and Streever, eds., 2016; Streever and Bishop, eds., 2014 and 2013). These collisions have likely been mitigated by speed restrictions and personnel training. Speed restrictions, on the Deadhorse-Endicott gravel road at least, are part of the Proposed Action activities since the road is a shared facility already in use. Since the combined length of gravel roads in BPXA's North Slope oil fields is approximately ten times that of Endicott Road (at a minimum) (see Bishop and Streever, 2016, Figure 5-3); assuming that the BPXA records reflect the results of mitigating personnel training, and allowing for potential incomplete record keeping, BOEM estimates that unmitigated vehicle collision numbers for the life of the Proposed Action could conservatively be in the tens to possibly hundreds for any species. Because these numbers are low relative to overall ACP breeding populations, they would have no more than local and short term, and therefore minor, impacts to tundra-nesting birds.

General Disturbance

Disturbance can also displace birds from areas around facilities. With no long-term human presence expected at terrestrial facilities, however, no other relevant disturbance effects to birds are expected for the Proposed Action other than those associated with traffic, construction, and marine facilities.

ESA-Listed Species

ESA-listed spectacled eiders could be disturbed and displaced by aircraft and vehicle traffic on the freshwater and terrestrial nesting grounds. Some foraging and migrating spectacled eiders and, rarely, Steller's eiders, could also be disturbed and displaced by vessel or helicopter traffic in nearshore waters.

Disturbance during the spectacled eider nesting and brood-rearing period (approximately June 5–August 15) could adversely affect individuals by: 1) displacing adults and or broods from preferred habitats during pre-nesting, nesting, and brood rearing, causing reduced foraging efficiency and higher energetic costs, and 2) flushing females from nests or shelter in brood-rearing habitats, exposing eggs or ducklings to inclement weather, damage, abandonment, and predators (Götmark and Åhlund, 1984; Livezy, 1980; Major, 1989). The behavioral response of nesting listed eiders to low-level aircraft flights is variable; some spectacled eiders nest and rear broods near the Deadhorse airport, indicating that some individuals tolerate or habituate to frequent, but regular, aircraft noise (Johnson et al., 2006). Flights associated with the Proposed Action that occur irregularly or in undeveloped areas (relative to an airport) over nesting or brood-rearing eiders, may cause spectacled eider to relocate to less favorable habitat. Eiders that abandon a nest probably will not nest again that year. An increase in vehicle traffic during the breeding season could cause direct mortality (through collisions); it may also disturb brood access to preferred habitats and waterways which could increase predation risk. The Proposed Action Area is a negligible fraction of a relatively low density portion of the total spectacled eider ACP breeding range (Larned, Stehn, and Platte, 2006), however. Traffic

(including both air and vehicle) impacts would occur to fewer than 3 or 4 nests over the life of the Proposed Action.

A few male spectacled eiders and early-departing females use early ice-free areas off river mouths and deltas—including the Sagavanirktok River Delta—in the summer, and the birds use coastal migration routes as the water opens up. A few spectacled eiders would likely encounter Proposed Action-related disturbances in these nearshore areas, first from hovercraft and helicopters during break-up, and then potentially helicopters and other vessels in more open water (Day et al., 2005; Troy, 2003). Eiders disturbed while in nearshore waters should react to the disturbances similarly to other sea ducks (described above), by diving, flushing, or avoiding the area. If eiders relocate to other areas, competition for food available following migration may result in lowered fitness. Summer flights to the proposed LDPI, particularly 2-4 a day, may displace some eiders from preferred marine foraging areas or coastal habitats occupied after young have fledged. However, few low-level flights are anticipated as part of the Proposed Action so displacement should be minimal. These flights are not likely to directly cause bird mortality, and as noted in Section 3.2.3, the nearshore Beaufort Sea waters are not habitat for large numbers of foraging spectacled eiders. Marine-area traffic (including both vessel and air) impacts to relatively low density spectacled eiders.

Available data on Steller's eider indicates that they are unlikely to nest near or migrate through the Proposed Action Area. Air and vehicle traffic impacts associated with the Proposed Action that occur over and on terrestrial areas likely would have greater temporary effects on nesting Steller's eiders than would marine disturbances, although impacts are expected to be negligible for Steller's eider even terrestrially because of the few low-level flights and the low occurrence of this species in the Proposed Action Area. Most onshore activities in the Proposed Action Area are likely to affect at most only one or two individuals.

Conclusion

Vessel, aircraft, and vehicle traffic associated with the Proposed Action would have a minor level of effect on non-listed and listed species, with the exception of a moderate level of effect on more densely occurring populations such as nesting snow geese, black brant, and Sabine's gulls. From November to early April, most birds are absent from the Beaufort Sea coastal areas (onshore and marine) and would not be affected by traffic. While certain types of transit conducted during periods and in locations of high bird density or sensitivity (e.g., repeated low-level flights over/ nearshore fast vessel trips near staging shorebirds or barrier island breeding birds) could potentially have moderate levels of impact, these types of transit are not routine activities associated with the Proposed Action.

Mitigation

Appendix C describes mitigation measures derived from lease stipulations, design features and BMPs the operator proposes to commit to, and requirements and BMPs that other agencies typically require (sections C-1 to C-3). BOEM's conclusions regarding impacts assume implementation of, and compliance with, the mitigation measures described in sections C-1 through C-3. A few of the more important measures, as relevant to traffic disturbances, are described below.

Appendix C (section C-4) also contains additional mitigation measures developed by subject matter experts. As it is speculative whether or not they would be included in the Proposed Action, consideration of the additional potential mitigation measures is not included in BOEM's analysis of population-level impacts, but the additional measures may be expected to further reduce numbers of birds affected.

Best Management Practices:

- Hilcorp would produce a plan for marine traffic procedures to avoid encountering concentrations of molting waterfowl (See 2015 Liberty DPP).

- Seasonal air traffic controls (e.g., routing and minimum altitudes) would be implemented over specific nesting and brooding areas (e.g., Sagavanirktok River Delta, Howe Island).

Additional Potential Mitigation Measures:

- Seasonal air traffic and vessel controls (e.g., routing and minimum altitudes) would be implemented in the vicinity of shorebird and waterfowl staging (including at the Sagavanirktok and Kadleroshilik River Deltas)
- Vessels would adhere to reduced speeds while transiting waterways that have sensitive shoreline resources (e.g., common eider, black guillemot, Arctic tern or other seabird or shorebird nesting sites).
- Vehicle speed limits would be reduced to 30 mph on the Endicott road system, except 15 mph on the north end of Endicott Road through saltmarsh and mudflat habitat during brood-rearing season, and all Proposed Action related roads between July 1–August 15 to minimize collisions and other impacts to waterfowl and shorebird broods.
- Personnel would be trained to watch for and stop for adult birds with broods attempting to cross roads.
- All avian mortalities and collisions (including vehicle collisions) and their circumstances would be reported to BOEM and USFWS. These data would help verify the assumption that collision mortality is low and negative effects are small.

Habitat Loss and Alteration

Habitat loss and alteration can affect prey abundance and have energetic, survivorship, and productivity effects on birds. Construction activities and structure emplacement can also affect behavior and destroy nests.

Terrestrial and marine habitat impacts are considered separately for all birds in the Proposed Action Area, and then for listed species in particular.

Terrestrial Construction/Habitat Alteration

Alteration of terrestrial and coastal habitats, including Arctic tundra and barrier island areas, can impact nesting, migrating, and foraging birds. It can cause reduction of available nesting and foraging sites for shorebirds, waterbirds, and passerines, and changes in overall bird species composition, within the footprint of the alteration (Meehan, 1986). It is possible that birds could be displaced to lower quality habitats, which can affect fitness and reproductive potential.

Beyond habitat loss in the directly altered footprint, other effects may also be expected to occur for avian species, especially nesting passerines and nesting and migrating waterbirds. For example, nesting or foraging areas could be lost due to habitat fragmentation from a road project (Barrows, Fleming, and Allen, 2011). Construction activities in intertidal and other coastal areas in the spring and fall can displace migrating birds from feeding areas during limited stopover and staging times, causing them physiological stress. Construction activities in wetland and upland habitats during the spring and summer breeding season would be expected to displace birds from nesting sites, or directly destroy eggs and flightless chicks of numerous nests. The destruction of active nests, eggs, or chicks would be a violation of the federal Migratory Bird Treaty Act (16 U.S.C. 703-712 et seq.).

Proposed Action activities that would affect terrestrial bird habitat (primarily wetland habitat as described in Section 4.3.6) include construction of pads (Badami tie-in pad, ice road crossing and pipeline landfall), the VSMs, and the proposed gravel mine (approximately 21 acres) west of the Kadleroshilik River. Altogether, these sites would result in permanent habitat loss on the order of 25

acres. Reclamation of the gravel mine site would ultimately convert vegetated tundra habitat into a lake.

The Wetland Delineation Report for the Proposed Project (Hilcorp, 2015, 2016), including the proposed gravel mine site and most or all of the tundra ice road routes, has identified the land as entirely wetlands, primarily a patterned ground complex of emergent wetlands, both seasonally and permanently flooded, and ponds. It was found to be “not rare for the North Slope, and similar habitats are found over millions of acres in the same Alaskan North Slope wetland complex,” and “(t)he wetland functions provided by these wetlands are not unique.” While not unique, the wetlands proposed for gravel extraction and pad development (i.e., permanent habitat alteration) currently provide habitat for migrating and nesting birds, including waterfowl, shorebird, and landbird species (Section 3.2.3).

Additional habitat acreage could be subject to seasonal and temporary impacts during the first years of the Proposed Project. Delayed melt in ice road footprints and associated snowdrifts could leave the following areas unavailable for early nesting, and vegetation under the ice would not be available for foraging until after the ice and snow melted by mid-summer:

- An ice pad constructed for overwinter overburden storage would temporarily restrict access to an estimated 28 acres of tundra habitat around the perimeter of the mine site during spring and early summer for one year.
- Ice roads (Ice Road #4, or the Badami Ice Road) to access the gravel mine would temporarily reduce access to approximately 70 acres of tundra habitat during spring and early summer for up to four years.
- The onshore portion of the ice road constructed in support of pipeline construction in the pipeline corridor to LDPI would temporarily reduce access to an estimated nine acres of tundra habitat during spring and early summer for up to four years.

In the above areas, early-nesting species, including greater white-fronted goose, long-tailed duck, Lapland longspur, semipalmated sandpiper, buff-breasted sandpiper, and red-necked phalarope could experience loss of breeding and foraging habitat.

In the case of delayed melt, other non-listed species, including king eider, American golden-plover, dunlin, long-billed dowitcher, pectoral sandpiper, stilt sandpiper, red phalarope, Arctic tern, Pacific loon, and rock ptarmigan (Bishop and Streever, 2016; Lanctot and Laredo, 1994; Saalfeld et al., 2013), could lose access to some breeding habitat. Most of these species are territorial breeders, with no colonies or unusually high density (relative to their overall ACP ranges) breeding areas present in the Proposed Action Area. It is possible that some of these birds, for example semipalmated sandpipers which appear to use a range of breeding habitat types (Hicklin and Gratto-Trevor, 2010; Smith et al 2012), may also find alternative suitable nesting habitat.

In general there is currently little evidence that displaced birds do find alternative breeding habitat, however. For purposes of conservative analysis, therefore, BOEM assumes permanent habitat loss within the Proposed Action Area of up to approximately 25 acres (0.1 km²), plus four years' temporary habitat loss up to approximately 125 acres (0.5 km²). Of the colonial-nesting species, greater white-fronted goose and Arctic tern may nest within the footprint of the gravel pit or ice road or pads but in low numbers (Streever and Bishop, 2014). Territorial-breeding birds directly impacted by a 150-acre loss could number in the single digits to tens per species, annually. Lapland longspur, and semipalmated and pectoral sandpipers would likely lose the most nesting sites, based on their highest relative densities in the vicinity (3.2.3.2), but these species also have high overall abundances and they would not experience measurable impacts relative to overall Beaufort Sea Coast breeding populations. Less common birds such as American golden-plover or buff-breasted sandpiper may lose up to one or two territories annually (Streever and Bishop, 2014).

Clearing and excavation of the proposed mine site would occur between January and April (1Q of the year, DPP Section 3.2), so no direct impacts to active bird nests are expected because. Similarly, disturbance impacts from onshore construction activities are confined primarily to the non-breeding season, would be localized, short-term, and temporary, and are planned to be confined to disturbance footprints that would be largely unsuitable for nesting.

Other aspects of the ice road construction would potentially alter local nesting distributions and habitat usage. For example, the proposed ice road north of the Badami pipeline crosses along the inland area of early-spring foraging habitats and summer brood-rearing habitats used by snow geese, tundra swan and brant. It would run closely parallel to the existing annual Badami ice road which is used for other projects. Delayed melt-out of the ice road would temporarily fragment adjacent habitat, which may lower habitat quality south of an important and relatively large fraction (i.e., half of the greater Sagavanirktok River Delta area) of their ACP brood-rearing habitat. The Badami ice road would only be used during initial construction however, and not be present during brood-rearing season in the late summer.

ESA-Listed Species

Nesting spectacled eiders occur commonly at relatively low densities on mainland tundra in the Proposed Action Area during summer. Over the life of the Proposed Action a few of these individuals could experience loss of tundra-nesting habitat as a result of gravel mine construction and/or the presence of ice roads. Because tundra would not be excavated after May or before September, it is not expected that disturbance from gravel mine development would directly impact breeding, nesting, or brood-rearing spectacled eiders. Construction activities still occurring when spectacled eiders arrive, however, could potentially prevent them from initiating nests or displace them from preferred nesting habitat (Anderson et al. 2007; USDOJ, FWS, 2015b).

USFWS recently estimated a potential loss of 4.88 spectacled eider nests for a 30-year gravel mine project at the nearby Kuparuk River oilfield. They assumed that for 300 acres, (including a 200 m buffer disturbance zone), 0.161 nests would be lost annually, and that 30 years x 0.161 nests = 4.88 nests lost over the life of the project (USDOJ, USFWS, 2015b). BOEM estimates that for the Proposed Project, approximately 25 acres would be considered a life-of-the-project loss: the 21-acre mine site area plus pads, landfall and VSMS. Using the USFWS (2015b) methodology and adding a few additional acres for buffers, and with 125 additional acres of four years' temporary loss assumed for ice road impacts, the total area would still be less than the 300 acres of Kuparuk loss and disturbance estimates. The Proposed Action would therefore affect less spectacled eider breeding habitat than the Kuparuk gravel mine and fewer than 4.88 nests would be lost over its 25-year lifetime. This is a minor level of impact to the spectacled eider population relative to a total ACP population in the low tens of thousands (3.2.3). Furthermore, pendant grass (*Arctophila fulva*), known to be a preferred habitat substrate for spectacled eider foraging and brood-rearing, was not found at the wetland mapping site investigated as the gravel pit location (ASRC, 2015). In summary, gravel mine construction would not result in the loss of relatively high density or valuable spectacled eider breeding habitat.

After gravel extraction, the proposed mine site would be rehabilitated over one summer season. A pond would remain, with part of its shore likely graded to a shallow slope and revegetated to provide enhanced waterfowl habitat. Without continuous (i.e., multi-year) restoration work, which itself can cause disturbance, the site is not expected to remain as a shallow pond and this site rehabilitation would be of negligible benefit to spectacled eiders and could have localized adverse effects if rehabilitation activities disturbed any eiders nesting in adjacent wet tundra areas.

Regarding Steller's eider, because of that species' low local population, (3.2.3), this species is not expected to be impacted by Proposed Action-related terrestrial habitat alteration.

Terrestrial habitat summary

The Proposed Action would result in the loss of nesting habitat for some Arctic avian species but the area affected would constitute an insignificant fraction of ACP nesting habitat relative to species' populations. Temporary and permanent habitat alteration areas are not known to be densely occupied during breeding or heavily used for migration staging or foraging, or other life history purposes, by any particular avian species. Disturbance impacts from onshore construction activities are expected to be minor as they are confined primarily to the non-breeding season and would be localized, short-term, and temporary. Some habitat fragmentation or degradation may occur from delayed melt-out of an ice road across the Sagavanirktok River Delta, but these effects are expected to be temporary. Altogether, terrestrial habitat impacts would be localized and primarily short-term, affecting birds at the individual rather than population level.

Impacts to Steller's eider are not anticipated because they nest in a relatively small area around Utqiagvik and nests in the Proposed Action Area are considered extremely rare.

Marine Habitat Loss and Alteration (Seafloor Disturbance)

Loss or alteration of benthic or pelagic habitats, potentially affecting prey abundance or availability by placement of fill, seafloor disturbance, or increased water turbidity, can impact foraging marine birds. Construction of the proposed LDPI would result in the permanent loss of about 24 acres of benthic avian foraging habitats. As described in Section 4.3.1, this marine habitat loss is not expected to have more than a minor level of effect on invertebrate prey communities relative to the overall amount of benthic invertebrate habitat available in Stefansson Sound and Foggy Island Bay, and relative to the short invertebrate community recovery time expected. Construction of the LDPI and an offshore pipeline could have additional effects on marine and coastal birds by temporarily altering additional benthic and pelagic foraging habitat via increased water turbidity from an increase in suspended sediments. Because most construction would occur during winter, much of the increase in turbidity should not affect foraging waterbirds. However, some increase in turbidity during spring and summer would result from the winter proposed LDPI construction, SDI hovercraft landing area modification, and pipeline construction. Increased water turbidity probably would decrease foraging efficiency for benthic- and pelagic-feeding waterfowl and pelagic-feeding loons. Displacement due to water turbidity would be temporary, localized, and short term.

ESA Listed Species

Offshore construction would bury about 24 acres of potential sea duck bottom-foraging area, representing, as noted in the previous paragraph for non-listed species, a very small portion of the available habitat. The construction of the LDPI and offshore pipeline would increase the amount of habitat disturbance or modification in the marine and terrestrial environments. Installation of the undersea pipeline would involve seafloor excavation which could disturb and/or degrade seafloor habitats and suspend fine materials in the water column. Nearshore foraging habitats also would be altered temporarily by increased turbidity from an increase in suspended sediments around the proposed LDPI and along the subsea pipeline route. See Section 4.3.1 for more information on impacts to benthic habitats.

Conclusion

Construction of the proposed LDPI and offshore pipeline would cause localized, temporary increases in water turbidity. Long-term sedimentation effects to some benthic organisms and permanent marine habitat loss from the LDPI seabed footprint are expected to result in no more than a slight reduction of the amount of available marine bird foraging habitat. All marine construction and habitat alteration activities combined are expected to have at most short-term and localized impacts effect on birds, including listed species.

Mitigation

Appendix C describes mitigation measures derived from lease stipulations, design features and BMPs the operator committed to which the operator is assumed to commit, and requirements and BMPs that other agencies typically require (sections C-1 through C-3). BOEM's conclusions regarding impacts assume implementation of, and compliance with, the mitigation measures described in sections C-1 through C-3.

Appendix C (section C-4) also contains additional mitigation measures developed by subject matter experts. Habitat loss and alteration and construction impacts are expected to be no more than minor. The scale of impact level, however, is in reality a continuum, and mitigation as described in Appendix C can help keep these impacts at the lower end of minor, and potentially reduced to negligible for some species. Particularly relevant measures are described below.

Appendix C (section C-4) also contains additional mitigation measures developed by subject matter experts. As it is speculative whether or not they would be included in the Proposed Action, consideration of the additional potential mitigation measures is not included in BOEM's analysis of population-level impacts, but the additional measures may be expected to further reduce numbers of birds affected.

Best Management Practices:

- Bird use and wetlands mapping in the vicinity of the onshore gravel mine site and gravel pads was considered in order to avoid high quality habitat, particularly for spectacled eiders and snow geese.

Other Agency Requirements:

- The USFWS typically requires adherence to Land Clearing Timing Guidance (USFWS, 2009). Vegetation clearing and land disturbance activities that could harm active nests, eggs, and nestlings (e.g., for the gravel material sites, fill pads, or any other purpose) would not occur between June 1 and July 31. (Note that USFWS is revising the timing guidance, and use of the most current version of guidance prior to site preparation is appropriate.)

Additional Potential Mitigation Measures:

- Abandonment and rehabilitation of the gravel mine site would be described in a Mining and Rehabilitation Plan submitted to ADNR and USACE for approval. Gravel mine site reclamation and pond development would be designed with USFWS assistance. This would include appropriate bank slopes, revegetation parameters, etc., so as to provide better and more diverse avian habitat use.
- Lethal take or disturbance to nesting birds during the spring and summer nesting period would be potentially additionally minimized or avoided by early staging of equipment on site and the employment of passive hazing techniques to deter birds from nesting in areas planned for construction or gravel extraction.

Light Attraction and Collisions

The physical presence of facilities has the ability to impact birds, including listed species, in several ways. Disturbance, displacement, and habitat loss impacts anticipated for the Proposed Action are analyzed elsewhere; this section analyzes the potential for impacts to birds caused by in-flight collisions, including collisions caused by attraction to artificial light and gas flaring (vehicle collisions are analyzed under Disturbance). First, the primary sources of these collision impacts are examined in regard to birds in general, and then listed species in particular. This is followed by conclusions of overall expected level of collision impacts for the Proposed Action.

The presence of new structures, including associated light sources, in the environment, can potentially result in energetic costs and mortality effects via attraction and collision. Structures in otherwise open areas can present a collision hazard to flying birds. (“Collision” is used herein to refer generally to a bird/structure encounter in which a bird does not independently and immediately depart. For example, exhausted or disoriented birds may alight on a vessel but not ultimately survive. To support a conservative analysis, all collisions are considered fatal.) Structure and vessel lighting is widely understood to exacerbate this hazard for many species, especially during migration and when conditions are stormy or foggy, or during certain lunar phases, and can result in attraction, exhaustion, and injury and mortality from collisions (Crawford, 1981; Day et al., 2015; Day, Prichard, and Rose, 2005; Ronconi, Allard, and Taylor, 2015; Montevecchi et al., 1999; Verheijen, 1981; Wiese et al., 2001). Both interior and exterior lighting, as long as it is visible to migrating flocks of birds under these environmental conditions, has the potential to disorient and attract; just as structures that are relatively new impediments in what for evolutionary time were unobstructed flyways have the potential to cause collisions. The two in combination can be particularly hazardous.

The physical presence of Proposed Action facilities—including the proposed LDPI, crane booms, onshore pipeline, and associated vessels—are expected to create collision hazards for birds. Occasional gas flaring from the LDPI is a potential incineration hazard as well. These hazards would be increased by light attraction at night under certain environmental conditions, and could draw additional birds in from surrounding airspace towards structures, including the LDPI, crane booms, drill rigs, vessels, and gas flare boom.

Some birds may be more prone to collisions with structures and vessels than others because of their typical flight pattern or attraction to artificial light. Bird species such as eiders that fly low over water have a greater potential to collide with offshore structures and ships, especially under conditions of poor visibility such as fog, precipitation, and darkness (e.g., Erickson et al., 2001). Strong headwinds can also increase collision risk by influencing migrating birds to fly lower (Richardson, 2000). Certain species, including common raven and raptor species, can also be attracted to stationary heavy equipment or vehicle storage areas for perching or nest sites. Many of these birds are predators on passerine and waterbird species (see “Increased predator abundance,” below).

Numerous avian species and species groups occurring in the marine and/or terrestrial Proposed Action Area are at particular risk of in-flight collisions. These include long-tailed ducks and eiders that migrate in large numbers along the coast and have histories of platform strikes, and other waterfowl species with similar habits of flying fast and low above the water are (Bruinzeel, van Belle, and Davids, 2009; Merkel, 2010; USDOJ, BOEM, 2015). Many passerines, shorebird species, and seabird species also appear to be attracted to vessels and offshore oil facilities, often due to light attraction at night (Black, 2005; Montevecchi, 2006; Montevecchi et al., 1999; Ronconi, Allard, and Taylor, 2015; Wiese et al., 2001). The year-round resident common raven and the locally common glaucous gull are among at-risk species with a history oil and gas facility collisions. Passerines, which are typically nocturnal migrants, have demonstrated high relative rates of light attraction and strikes in Alaskan waters and elsewhere (USDOJ, BOEM, 2015e; Shell Gulf of Mexico Inc., 2012, 2015; Bruinzeel, van Belle, and Davids, 2009).

Offshore, many species of birds would collide with any portion of the LDPI, especially vertically walled tanks and edifices, crane booms, drill rigs, and gas flare booms. Birds would collide with some Proposed Action- associated vessels, particularly larger, well-lit vessels that may remain offshore in marine waters for extended periods (e.g., assist tug). Reports of annual bird mortality rates at oil and gas facilities from collisions, nocturnal circulations, and incineration vary based on avian group, location (especially in relation to migratory pathways), and survey methodology (Ronconi et al., 2015). Some information on waterfowl collisions during fall migration has been collected from Northstar and Endicott SDI. A minimum average of 5 common and king eiders and 4 long-tailed duck strikes were reported over four partial fall migration seasons at Northstar (Day, Prichard, and Rose,

2005). Aside from an unidentified swan and goose, these 3 were the only waterfowl species recorded in strikes at BPXA North Slope oil field facilities (including Northstar), between 2010 and 2014 (Bishop and Streever, 2016 ; Streever and Bishop, 2014, 2013). At least 16 common and king eiders were reported together at Endicott SDI, between Northstar and the Proposed Action site, in October of 2001 (USFWS, unpublished data). Long-tailed duck and raven have also been reported downed at Endicott SDI (Streever and Bishop, 2014).

Systematically-collected bird collision survey data is available for off-shore oil and gas exploratory drilling units and associated vessel support in the neighboring Chukchi Sea. Many of the same species at risk of collision in the Beaufort Sea are also at risk in the Chukchi Sea, as the facilities themselves are similar (from the perspective of migrating bird flocks) in vertical elevation profile and relative light output. BOEM estimates an average rate of 28 reported strikes/platform/year and 7 strikes/support vessel/year from data collected over two recent open-water exploration drilling seasons in the Chukchi Sea at sites ranging out as far as approximately 60 miles from shore and 150 ft in water depth (USDOJ, BOEM, 2015; Shell Gulf of Mexico Inc., 2015, 2012). Strikes included approximately 30 species of passerines, seabirds, shorebirds, sea ducks, and a short-eared owl. These species are known or assumed to migrate or occur over the offshore Proposed Action Area as well, and based on these similarities and adjacencies with gravel islands, platforms, and support vessels, are expected to be among future collisions resulting from the Proposed Action.

Besides individual strikes, strike events of flocks (i.e., multiple individuals of one or more of many species), are also expected to occur. Several such events were reported in the two years of Chukchi Sea drilling, often involving two or three but up to 10 long-tailed ducks, 11 king eiders, and 12 passerines each. For the Proposed Action, these are expected minimum rates, because while some birds found aboard platforms from strikes actually recover, many more are believed to strike and fall unnoticed in to the sea (Ronconi, Allard, and Taylor, 2015). For species with large stable populations these losses, although chronic, would not have long-lasting population effects, and therefore have no more than minor levels of effect.

Over the life of the Proposed Action, as the environmental baseline changes with a changing climate, environmental circumstances could align with migration timing for a species with a relatively low or declining population and a large circulation or flock collision or collisions may be possible. Rusty blackbird, a sharply declining neotropical migrant, for example, was recorded among the offshore collisions in the Chukchi Sea in both 2012 and 2015. With the relatively inshore location of the Proposed Project and no prior evidence of strike events of this order in 15 years of data collection at similar gravel islands, however, strike impacts to even vulnerable species are not expected to be long-lasting or widespread (e.g., a loss on the order of 100 or more breeding-age rusty blackbirds or buff-breasted sandpipers, particularly more than once).

Onshore Pipeline and Equipment

Birds in flight, particularly waterfowl during migration, are at risk of collision with terrestrial facilities, e.g., the onshore pipeline, and large stored heavy equipment such as cranes or drill rigging. Both spring and fall migration of most species of arctic-nesting sea ducks involves overland routes (Peterson and Savard, 2015). Day et al., 2005, found that eiders in September flew at a mean altitude of 6m, and as low as 1m, and long-tailed ducks flew at a mean altitude of 2m. They found that in the Point Barrow and Prudhoe Bay areas, as elsewhere, collisions of migrating waterfowl, especially eiders, with wires and other infrastructure are common, particularly so during periods of heavy fog (USFWS, unpublished data, as reported in Miller et. al., 2016 ; Stout and Cornwell, 1976; Drewitt and Langston, 2008; MacKinnon and Kennedy, 2011). Because the pipeline would not be lit, and therefore attract additional birds in to face collision hazards, fewer annual collisions with the pipeline should occur than with the lighted LDPI and vessels. As with marine infrastructure collisions, the

potential of collisions with the onshore pipeline and any large stored heavy equipment is expected to be greatest during periods of fog and low visibility during migration.

Non-listed species carcasses (possible strikes) at BPXA operated onshore Beaufort Sea coastal area oil field facilities between 2010 and 2014 include king eider, common eider, a ptarmigan, glaucous gull, rough-legged hawk, raven, American robin, Lapland longspur, snow bunting, and dark-eyed junco (Bishop and Streever, 2016; Streever and Bishop, 2014, 2013). These species are therefore among those considered at risk of collision with onshore Proposed Action facilities. Strike numbers would not be comparable to or include those potentially caused by light attraction, and would be expected to remain in single or double digits or less per year, below population level effects.

Gas Releases

Gas flaring produces extremely bright ambient light at night, and can attract a variety of bird species including long-tailed ducks, glaucous gulls, and passerine species (Day et al., 2015; Wallis, 1981; Wiese, et. al., 2001). Gas flare events have had extreme consequences for birds, especially passerines, as with the September 14-15, 2013, New Brunswick, Canada Canaport LNG gas flare that killed 7,500 songbirds during migration (CBC News, 2015). Some species become entrapped in nocturnal circulations around artificial lights, and may eventually die from collision, exhaustion, or overexposure to heat or incineration by flares (Ellis et al., 2013; Hope-Jones, 1980; Montevecchi, 2006; Ronconi, Allard, and Taylor, 2015; Russell, 2005; USDO, BOEM, 2015a).

The Proposed Action would include a flare system for burning off excess natural gas that may, over its 25-year life, be expected to flare off excess natural gas at such a rate and time that an intense bright light is created. This light may occur on a night during the aviation migration period, impacting birds. Although the flare is planned “not to exceed 4.0 MMscf/day” (Hilcorp, 2015, Section 9.4.3), unplanned gas flaring incidents do occur. Furthermore, although there may be daylight during most nights in the Arctic migration seasons, low visibility nights do occur when there is enough differential in light intensity between the ambient sky and a gas flare event to attract birds. A gas-flaring event at Northstar Island on a September night during fall migration was clearly shown by radar to attract large numbers of night-migrating birds, in spite of a repelling effect noted for some species for the anti-collision light system. Besides being attracted to the gas flare, bird flocks exhibited erratic flight behaviors, circling Northstar Island repeatedly. Long-tailed ducks and, to a lesser extent, glaucous gulls, were the primary species affected, and 22 flocks of long-tailed ducks appeared to be attracted and disoriented, with four flocks almost hitting island buildings before making extreme changes in both flight direction and altitude to avoid imminent collision (Day et al., 2015). Such flare induced events, if repeated in future years with changing environmental baselines, could cause long-lasting impacts to certain vulnerable species.

Listed Species

Migrating spectacled and Steller’s eiders, which typically fly at low altitudes (average = 20 feet) along the coast, and have high flight speeds (average = 50 mph) and low maneuverability (Day et al., 2005) appear to be particularly susceptible to collision-caused mortality. The collisions, often as flocks, of similar species e.g., common eider and king eider, and long-tailed duck, with offshore oil infrastructure and vessels elsewhere in northern waters are well-documented (Merkel, 2010; USDO, BOEM, 2015e; Bruinzeel, van Belle, and Davids, 2009) . Spectacled and Steller’s eiders have also been reported to collide with powerlines and other infrastructure on the ACP. One strike of a spectacled eider was reported on a vessel associated with the Chukchi Sea oil and gas exploration activities in 2015, several king eider and long-tailed ducks, including flocks, have struck Northstar Island, oil and gas facilities on the ACP, and Chukchi Sea exploration platforms (Shell, 2012, 2015). Strike reports are considered minimum measures of mortality as some birds are believed to strike and fall in to the sea or be scavenged unnoticed. The only difference in susceptibility to collisions is likely to be that king eider and long-tailed duck are much more abundant locally than either spectacled or,

especially, Steller's eider. Given the similarities in behavior it is possible that collisions involving flocks of listed spectacled eiders could occur, and given their relatively low population, this could result long-lasting and therefore minor to moderate levels of impact.

USFWS reports, regarding the susceptibility of spectacled eiders to collisions with non-lighted onshore facilities (i.e., the onshore gas pipeline and large equipment) extending in to the average elevation of central Beaufort Sea coast eider migratory flight routes (USFWS, 2013b):

Eiders migrating east during spring and west during summer/fall would be at risk of colliding with [onshore] structures. These structures include the light poles, buildings, drill rig, communication tower, overhead powerlines, and guyed power poles. However, we expect most eiders to remain offshore during spring migration because they are thought to follow open-water leads in pack ice during their spring migration to breeding grounds (Woodby and Divoky, 1982; Johnson and Richardson, 1982; Oppel et al., 2009; M. Sexson, USGS, pers. comm.). During post-breeding migration in summer and fall, we anticipate that male eiders would have the greatest collision risk in the action area. However, we anticipate spectacled eider collision risk with [onshore] structures from mid-May through late July would be greatly reduced by the visibility of structures during 24 hours of daylight in the Action area. When females and juveniles migrate during late summer/fall, decreasing daylight and frequent foggy weather conditions could increase collision risk. Longer nights increase the duration that eiders are vulnerable to collisions with unseen structures, and may compound susceptibility to attraction and disorientation from Action lighting. However, we anticipate sea ducks, including spectacled eiders, would be more likely to migrate over open water in the Beaufort Sea (Petersen et al. 1999, TERA, 2002), thereby avoiding inland ... structures....

Overall, we anticipate risk of spectacled eider mortality from collisions with Action infrastructure would be low [however]... an unknown level of collision risk remains, and this risk will persist over the estimated 30-year Action life.

... We acknowledge the proposed [onshore structures] constitute a long-term, if not permanent, collision risk to migratory birds in the Action area, including listed spectacled eiders. ... we speculate... that 5 or fewer spectacled eiders would collide with wires over the life of the Action. Given that the North Slope-breeding population of spectacled eiders is estimated to be 11,254 (8,338–14,167, 95% CI), and authorized take equates to 1 adult bird every six years, this impact would be so minor that population level effects from [onshore] collisions are not expected. (USFWS, 2013b)

The onshore pipeline planned as part of the current Proposed Action is, at 2.4 km (1.5 mi), shorter, and should be more noticeable to birds during good visibility conditions than the narrow, 3.6 km (2.2 mi) power line in the referenced project above. The onshore pipeline is, however, oriented approximately perpendicular to coastal migratory pathway of spectacled eiders and is, at 2.13 m (7 ft), within their observed average flight height above the tundra. The USFWS also partly based the spectacled eider risk of collision for the above-referenced onshore power line project on mitigations (lighting, design features) applied to that Proposed Action. The likelihood of onshore collisions would therefore be low but not negligible.

Based on the anticipated risk and the observed history of eider collisions offshore, added to the smaller onshore risk as described for the Miluveach River project (USFWS, 2013b), the combined level of collision impacts on listed spectacled eiders is expected to be at relatively low numbers but chronic and potentially long-lasting, and therefore minor to moderate.

Conclusion

The presence of the proposed LDPI and other facilities would present on-going hazards to individuals, but are not expected to have population-level effects, and therefore have a minor level of effect on most non-listed bird species. Once the proposed LDPI is built in the marine environment it would remain an obstruction to birds as long as it supported any vertically-rising, tall and/or lighted structures. The greatest hazard would be during the construction and decommissioning years when drill rigs are present, but as long as the LDPI remains lighted in the intervening years, the risk level would remain almost as high. Based on best available information from local and other relevant sources, a minimum of tens to hundreds of flying birds would collide annually with the LDPI and associated vessels. Many of these would be the result of night time light attraction. Flock collision events of multiple individuals, especially passerines and sea ducks would occur regularly. Irregular gas flare events, should they occur during certain low visibility conditions during peak migration periods, have the potential of causing flock collision events. All collisions are assumed to cause direct mortality. A few additional collisions, possibly in the singles and low tens per several species annually, could occur at onshore facilities or equipment. Species with stable populations would be able to withstand these levels of mortalities with no long-lasting impacts.

It is also possible there could be relatively chronic direct mortality for years that is relatively large proportional to declining or otherwise vulnerable populations. Certain species that migrate through the Beaufort Sea coastal areas with higher collision risks, and/or are known to be facing population declines or be limited in number (e.g., listed spectacled eider), could face more long-lasting impacts from light attraction and strikes.

In summary, while strike hazards of non-listed birds may be chronic, the actual impacts on non-listed bird populations from the physical presence of platforms (and associated vessel traffic), including lights and gas flaring, are expected to range from negligible to minor, because of their generally short-term and localized effects, depending on species. For listed spectacled eiders, these effects could be considered minor to moderate, due to the species' low population and thus the more potentially long-term but less than severe impact.

Mitigation

Appendix C describes mitigation measures derived from lease stipulations, design features and BMPs to which the operator is assumed to commit, and requirements and BMPs that other agencies typically require. BOEM's conclusion regarding impacts assumes implementation of, and compliance with, the mitigation measures described in sections C-1 through C-3.

Appendix C (section C-4) also contains additional potential mitigation measures, recommended in recent peer-reviewed literature and developed by subject matter experts. Adherence to these additional mitigation measures would be expected to further reduce the number of bird strikes, and monitoring would allow for adaptive management (such as revised lighting operations during certain weather patterns or seasons) that would be expected to also reduce bird strikes.

Because lights and physical presence of facilities, at some level, are an integral part and unavoidable impact of the Proposed Action, mitigation may not achieve an overall negligible level of impacts for all species, remaining minor for some birds. The number of individual collisions, however, would be reduced. Mitigation measures are described below.

Lease Stipulation:

- Stipulation No. 7 of LS 202: Lessees are required to implement lighting requirements that minimize the likelihood that spectacled or Steller's eiders would strike exploration or delineation structures. Modification of lighting protocols would be undertaken if new

information on bird avoidance measures becomes available. Lessees must also include a plan for recording and reporting bird strikes.

Best Management Practices:

- A lighting plan will be developed and implemented to minimize the potential for bird strikes.

Additional Potential Mitigation Measures:

- The lighting plan would include details on design, installation, and day-to-day operation of lighting on the LDPI and large vessels (e.g., assist tug and similar length or larger which may be offshore over-night or longer). Plan will be developed in cooperation with the USCG, BOEM, USFWS, and FAA, and will include a contractor/staff education component to increase efficacy of Lighting Plan operations and ensure minimization of potential for bird strikes.
- The LDPI would be designed such that all exterior lights are reduced and down-shielded (as safety and Action Plan operations allow). The U.S. Fish and Wildlife Service has recently published recommended guidelines for reducing bird collisions with buildings and building glass, and the FAA has, and while these are not specific to oil and gas facilities, the lighting design and operations recommendations (e.g., avoid unnecessary lighting; install motion sensors on all lights; ensure exterior lighting is “fully shielded” so that light is prevented from being directed outward, except as necessary for safety, and skyward; minimize light operation during bird migration periods; etc.) have general applicability (USFWS, 2016). Black-out curtains should be used to reduce attraction to interior lights.
- Use shorter wavelength lights for proposed LDPI exterior lighting. Recent research suggests that birds are less attracted to shorter wavelength light and that installing green and blue artificial lights at structures as an additional mitigation strategy will decrease the number of mortalities among nocturnally migrating birds (Marquenie et al., 2014; Poot et al., 2008). In the North Sea studies indicated that different colored lights cause different responses. White lights caused attraction and red caused disorientation, while green and blue caused a weak response. White lights were replaced with lights that appeared green, and this resulted in 2 to 10 times fewer birds circling the offshore platforms. (Verheijen, 1985; Montevecchi, 2006; Gauthreaux and Belser, 2006).
- Design and implement a strobe-based light-repellant system similar to Northstar. Such a system apparently has had some success in minimizing collisions of some species (Day et al., 2005; Greer et al., 2010).
- Reduce the attractiveness of the LDPI to migrating birds in general by painting buildings light tan, rather than white or very dark colors (Day et al., 2015).
- Lower and, whenever possible, remove all crane booms when not in use (Day, Prichard, and Rose, 2005). Do not store unused cranes or other large heavy equipment on-site.
- Develop and implement a Gas Flare Plan. The potential impacts of gas flares will be reduced by employing the following measures:
 - Ensure that the height of the end of the flaring boom is higher than the mean flight altitude of low-flying at-risk species, such as has been suggested to be beneficial in the case of the flaring boom at Northstar Island (Day et. al, 2015), The gas flare boom(s) will be at least 66 m (215 ft) high.
 - Include operations planning and education to minimize unnecessary gas flaring during low visibility nights in the height of spring and fall passerine migration season (April 20–May 30 and July 20–September 20).
- Remove the onshore portion of the pipeline after Proposed Action is complete.

- Develop and implement a Monitoring Plan that, at minimum, provides for daily (or first light) surveys of the LDPI for the presence of birds, alive or dead. Basic monitoring and mitigation protocols are commonly recognized as appropriate strategies for tracking and reducing collision mortalities at artificial structures, including oil and gas platforms. One potential component of a mitigation strategy is monitoring in the form of comprehensive tracking, following pre-determined and scientifically approved protocols, of attractions, collisions, and ultimate fate of grounded birds, to obtain improved and more comprehensive assessments of the impacts associated with platform and associated vessel attraction (Wiese, et al., 2001; Hatch Associates Limited and Griffiths Muecke Associates, 2000; Baillie et al., 2005; Ellis et al., 2013). Monitoring also can result in site or condition-specific data that can allow for adaptive management in lighting operations and other potential mitigation strategies. Records shall be kept according to protocols developed in cooperation with BOEM and the USFWS, and reports will be annually submitted to BOEM and USFWS. The Monitoring Plan would include an Adaptive Management component, and complement the Gas Flare and Lighting Plans.

Increased Predator Abundance

The physical presence of new facilities associated with the Proposed Action are expected to increase the number of potential nesting and perching sites for avian nest predators and increase availability of anthropogenic food and nesting/denning (e.g., for foxes) resources for predators. These factors can lead to locally increased abundance of certain Arctic fauna that prey on eggs and chicks. Some of what are sometimes referred to as the “subsidized” predators include common raven, foxes, and gulls. Some level of nest predation is part of the natural tundra ecology of the ACP. Nest predation has been observed to be the most common cause of nest failure in general (Liebezeit et al., 2009). An artificial, or subsidized, increase in predator abundance, however, may lead to locally decreased productivity of some avian species near Proposed Action activities (Liebezeit et al., 2009).

Activities associated with the Proposed Action that would likely lead to increased predator abundance include construction of year-round facilities, long-term storage of heavy equipment such as cranes, and increased human presence (and associated increase of food and trash). Fauna that feed on the eggs and young of birds in the Proposed Action Area and have been shown to benefit from proximity to human development on the ACP are arctic fox, red fox, common raven and glaucous gull (Liebezeit et al., 2009, Liebezeit and Zack, 2008 and 2010; Bishop and Streever, 2016; Streever and Bishop, 2014, 2013). Bears also are nest predators on the ACP and can quickly learn to exploit human food resources (4.3.4.6 and 4.3.5.3). Jaegers are common nest predators, but they are a “non-subsidized predator” (Liebezeit et al., 2009) and their abundance is not demonstrated to be related to human development.

Permanent structures that would be potential nest and perching sites include cranes, the onshore pipeline, support pads, and LDPI. Temporary structures that would provide nesting and perching sites would include drill rigs during the initial and decommissioning Action years. No new gravel roads or permanent onshore buildings or other structures are planned, which would help to minimize fox denning and the perching and nesting of avian predators on land. Glaucous gull will be absent in winter, but the common raven is likely to occur regularly near the Proposed Action in the winter. Overwintering survival of ravens could be positively affected through access to waste heat from buildings, cover, and potential increased access to food. Increases in the number of nesting ravens in the vicinity of the LDPI could lead to decreased productivity of other tundra-nesting birds through increased nest depredation.

ESA-Listed Species:

Productivity of spectacled eiders nesting near any of the Proposed Action facilities could be reduced through artificial increases in the abundance of common ravens or foxes attracted to the facility.

Ravens are highly efficient egg predators (Day, 1998), and have predated on Steller's eider nests near Utqiagvik (Quakenbush et al., 2004). Studies of Steller's eiders near Utqiagvik suggest a relationship between predation rates and breeding success (Quakenbush et al., 1995; Obritschkewitsch et al., 2001; Rojek, 2008; Safine, 2011) and a similar relationship for spectacled eider may be expected. Therefore, as the number of structures and anthropogenic attractants associated with the Proposed Action increase, of listed eider reproductive success may decline.

Because Steller's eiders are unlikely to nest in the Proposed Action Area, they would not be affected by any artificial increase in predator abundance that might occur.

Conclusion

Because of the physical presence of new infrastructure and increased human presence, an increase in nest predators, specifically ravens, Arctic and red foxes, and glaucous gulls is expected to accompany new infrastructure and increased human presence. Permanent (i.e., life-of-the-Proposed Action) structures including the LDPI and support pads and pipelines would provide long-term habitat enhancements for nest predators. Temporary presence of cranes and drill rigs would provide additional temporary perch, and possibly nest, sites. Unmanaged predator levels may influence local population levels. Passerine nestling survival has been sharply reduced by predation within 5 km (3.1 mi) of oil and gas infrastructure on the ACP. Given that predation levels are unlikely to be reduced to pre-construction levels, and therefore may be localized but long-lasting, the Proposed Action would have a minor to moderate level of impact on local populations of nesting shorebirds, waterfowl, loons, and passerines.

Mitigation

Appendix C describes mitigation measures derived from lease stipulations, design features and BMPs to which the operator is assumed to commit, and requirements and BMPs that other agencies typically require (sections C-1 through C-3). Implementing these BMPs would reduce or slow the rate of, increasing numbers of subsidized avian predators and increased predation on tundra-nesting birds. BOEM's conclusion regarding impacts assumes implementation of, and compliance with, the mitigation measures described in Appendix C (sections C-1 through C-3).

Appendix C also contains additional potential mitigation measures, developed by subject matter experts (section C-4). Implementing the additional potential mitigation measures successfully would keep increased predation impacts on birds, including listed species, from the Proposed Project Action from exceeding minor levels. Mitigation measures, as relevant to increased predation, are described below.

Best Management Practices:

- Towers and other structures on the LDPI will be designed to reduce opportunities for predatory bird (e.g., raptor, common raven) nesting.
- Strict food waste control (e.g., animal-proof dumpsters) will be employed during construction and operations to avoid attracting predators.

Additional Potential Mitigation Measures:

- Work with BOEM and USFWS staff to develop a Wildlife Interaction Plan that at minimum includes the following:
 - Contractor/employee education on: problems associated with feeding wildlife and prohibitions against feeding or encouraging wildlife; reporting all wildlife encounters; and training on waste management and use of animal-proof dumpsters
 - Monitoring for detection of nest building by predatory birds on towers or other structures, and fox denning on or near any of the Proposed Action facilities

- Discouragement of nest building and denning activities.
- A procedure for reporting all evidence of predator attractions to the facilities, including nesting or denning; anthropogenic feeding, food caching, or stealing; persistent perching; etc., for the purpose of adaptive management.
- Removal of (i.e., to include egg treatment or other methods as appropriate for prevention of successful nesting and re-nesting) any found nests or dens as appropriate under all applicable legal requirements including State and Federal laws and permits.
- All potential necessary permits for nest and den removal or other wildlife interactions, as discussed/approved/permitted in advance as necessary with appropriate State of Alaska and federal regulators prior to initiating construction.

Oil Spills

Oil spills have a high potential to affect birds. The magnitude and extent of impacts is a function of the time of year the spill occurs, the volume and product type, the environmental conditions at time of spill, the species and/or habitats and habitat quality exposed, and results—beneficial and/or negative—from any clean-up activities. Timing (i.e., if peak periods in bird density overlap temporally with the spill), location (high- versus low-density areas), and environmental conditions (wind conditions, wave action) may have a greater overall effect on avian mortality than the spill size and fluid type (Byrd, Reynolds, and Flint, 2009; Castège et al., 2007; Fraser, Russell, and Von Zharen, 2006; Wilhelm et al., 2007). Presence of sea ice can affect oil spills and oil spill response in a number of ways such as trapping oil for various periods of time and otherwise impacting extent of oiling, rate of oil migration, dispersion, and weathering, and in turn largely affecting response strategies and timeline (Arctic Council, EPPR, 2015).

Certain species of birds may be more susceptible to contact with spilled oil than others: seabirds and sea ducks are initially most vulnerable to offshore oil spills because they spend the majority of their time in marine waters and often aggregate in dense flocks. Diving birds and underwater swimmers are susceptible to spilled oil because of their relatively long exposure time within the water and at the sea surface (Camphuysen, 2007). Birds in shoreline and wetland habitats may be susceptible to direct oiling if, for example, a spill were to reach the beach intertidal zone where shorebirds and other species forage, or inshore wetland habitats where waterfowl, shorebirds, and other species nest and raise young. The exposure to marine and coastal birds could range from acute (birds may be covered by lethal amounts of oil) to chronic (birds are exposed to smaller amounts of oil over a longer period of time). Effects of chronic exposure can range from lethal to sub-lethal.

Common routes of exposure to oil include covering skin or feathers, inhalation of vapors, and ingesting oil or contaminated prey. Chronic exposure can lead to reproductive effects and reduced food sources and fitness. Oil spills have the greatest potential for affecting large numbers of birds in part due to toxicity to individuals and their prey and the difficulties involved in cleaning up spills in remote areas, and with the wide variety of possible ice conditions.

Direct contact with oil can irritate or inflame sensitive tissues (e.g., skin, eyes) and foul plumage, which is the primary cause of stress and mortality in oiled birds (Balseiro et al., 2005; Burger and Fry, 1993). Oil causes marked loss of insulation, waterproofing, and buoyancy in the plumage, causing hypothermia, exhaustion, starvation, or drowning deaths (Balseiro et al., 2005; Wiese et al., 2001). Even small volumes of oil (i.e., oil sheens) are a concern for diving birds because of the potential to compromise thermoregulatory capabilities (Fraser, Russell, and Von Zharen, 2006; Jenssen, 1994; Wiese and Ryan, 2003). O'Hara and Morandin (2010) documented measurable oil transfer to feathers with small quantities of oil absorption. Even a light coating of hydrocarbons can negatively affect feather microstructure, potentially compromising buoyancy, insulation, and flight characteristics.

Oil ingested and inhaled during feeding, grooming, and preening can lead to tissue and organ damage, interfere with food detection, predator avoidance, homing of migratory species, disease resistance, growth rates, reproduction, and respiration (Balseiro et al., 2005). Ingested oil causes short- and long-term reproductive failure in birds, including delayed maturation of ovaries, altered hormone levels, thinning of eggshells, reduced egg productivity, reduced survival of embryos and chicks, reduced chick growth, and abandonment of nests by adults (Burger and Fry, 1993; Golet et al., 2002; Piatt and Andersen, 1996). Additionally, lightly oiled birds could bring oil contamination or contaminated food to a nest while heavily oiled birds would be unable to return to the nest, resulting in abandonment and starvation of the young. Impacts of lost reproduction from mortality of breeding-age adults must also be accounted for (Deepwater Horizon NRDA Trustees, 2016). For purposes of this analysis, all birds contacted by oil are assumed to die.

Prey items and other food resources used by birds may also be reduced in quantity (e.g., fish or invertebrate prey may experience mortality as a result of a spill, or there may be effects to primary producers that carry up through the food web (Golet et al., 2002). Habitat fouling that reduces habitat quality can also lead to displacement of affected birds to secondary locations (Day et al., 1997; Esler et al., 2002; Golet et al., 2002; Lance et al., 2001; Wiens et al., 1996). Chapman (1981, 1984) conducted a study of the impact of the 1979 Ixtoc exploration well oil spill on shorebirds, and found that oil on the beach caused birds to shift their habitat selection to less productive areas. Displacement of bird species from a portion of preferred feeding grounds can result in additional energetic requirements and increased foraging time for parents feeding chicks and for migrating birds, potentially affecting productivity (Golet et al., 2002) or making them unable to complete their migration.

Details of impacts to birds as a result of spills associated with the Proposed Action are described below.

Small Oil Spills (<1,000 bbl)

The majority of small accidental spills would be <10 bbl, so those that do enter the water column would quickly dissipate, and would be unlikely to affect habitat or individual birds. Small spills ≥ 10 bbl but <200 bbl would be similarly relatively easy to contain and may affect small areas of habitat and few individuals.

Should a fuel spill occur during refueling and escape containment, a small number of birds in the immediate vicinity of the vessel could be affected, depending on current and wind patterns. Few birds, however, are likely to be in the area during refueling and in the unlikely occurrence of a fuel spill, a limited number of individual bird mortalities could occur.

Small spills would be expected to result in short-term impacts to small areas. For isolated small spills, negligible to minor impacts are expected to birds. Population-level effects would not occur for small accidental spills. Widespread annual or chronic disturbances or habitat effects are not anticipated to accumulate across one year, and localized effects are not anticipated to persist for more than one year.

Large Oil Spill ($\geq 1,000$ bbl)

As with small spills, the magnitude and severity of impacts would depend on the spill location and size, type of product spilled, and environmental conditions and presence of birds.

A large crude oil spill may be difficult to contain and could result in lethal and sublethal effects on relatively large numbers of birds, depending on the season and location. The Beaufort Sea and ACP bird community is complex and includes many species, a number of which occur in great abundance and a variety of life stages and habitat usages that differ with location and time of year. There are varying degrees of vulnerability to exposure to an oil spill, depending on season, location, and duration of spill. Impacts could include oiling of plumage, ingestion of oil from preening, oiling of

foraging habitats, and displacement to secondary locations. Landbirds, shorebirds, seabirds, or waterfowl, including listed spectacled eiders, could be impacted depending on if the spill occurred on land, in nearshore or coastal waters or in the presence of birds offshore.

Vulnerability may vary slightly for different age classes of certain species, such as juvenile versus adult phalaropes (Taylor et al, 2010). Certain exposures are of particular concern for birds in the Beaufort Sea Proposed Action Area. For example, concentrations of birds at certain times of year put large numbers of birds at risk from a single accidental event, as with the waves of hundreds and thousands of shorebirds that move through the local river deltas and coastal mudflats foraging as they stage for fall migration. Reproductive impacts are also of significance given the short summer period at high northern latitudes and the high energetic investment in egg laying.

Because the proposed LDPI is relatively nearshore (i.e., approximately 5 mi, and well within the outer barrier islands), the season (e.g., late spring, fall) of a large spill is likely to have a greater effect on birds than the point of origin (i.e., whether a spill originates at the LDPI or offshore pipeline), or spill volume. Once breeding birds begin arriving in spring, abundances grow sharply within weeks. The earliest birds (e.g., snow bunting, tundra swan) begin arriving on the tundra in April, and thousands of birds, including greater white-fronted goose, black brant, phalaropes, long-tailed duck, king eider, and Lapland longspur may be present in coastal waters and onshore tundra of the Proposed Action Area by mid to late-May (Ward et. al., 2015; Cotter and Andres, 2000).

Populations of different species will variously grow and shrink over the spring, summer, and fall as they breed, molt, stage, and then migrate. Birds will remain present in the area and vulnerable to spills in substantial numbers, until most migrants depart from the Proposed Action Area and the Arctic by freeze-up (though a few seabirds use distant areas of open water even in winter). Numerous non-listed species that could be directly contacted by a large spill occurring in the marine environment in either spring, summer or fall months (i.e., May–October) include those listed in the preceding paragraph, plus king and common eiders; surf, white-winged, and black scoters; long-tailed ducks; red-breasted and common mergansers; red-necked and red phalarope; jaegers; black guillemot; black-legged kittiwake; glaucous and Sabine’s gulls, Arctic tern; Pacific, red-throated, and yellow-billed loons; and short-tailed shearwater. The largest concentrations or abundances of species in local marine waters typically include breeding and post-breeding long-tailed ducks, king and common eiders, post-breeding rafts of scoters, glaucous gulls and phalaropes (Stehn and Platte, 2002), and these species would likely be those that would experience the highest numbers of direct mortality via contact with a large spill.

If a large spill reaches coastal waters without containment, it is also likely to impact tundra swans, geese (e.g., lesser snow geese, brant), and dabbling ducks such as northern pintail and American wigeon that are commonly found along Beaufort Sea barrier islands and mainland shores. Should a spill reach coastal mudflats, saltmarshes or river delta habitat, large numbers of staging shorebirds, including sandpiper species like pectoral, semipalmated, and buff-breasted, and brood-rearing geese and other waterfowl could also be impacted. BOEM conducted an Oil Spill Risk Analysis (OSRA) for a large spill, detailed below, that lists areas estimated to be contacted and the percent chance of contact to these areas.

A large spill that originated from the onshore pipeline and occurred on terrestrial habitat during the spring or summer would not spread as far in surface habitat as an uncontained marine spill, but could potentially impact brooding lesser snow geese and brant, pectoral and semipalmated sandpipers, and Lapland longspur. It may also affect lower density but still common breeders like loons.

Birds that are not directly oiled could be affected by impacts to nearshore and intertidal invertebrate or fish food resources, which would be expected to incur moderate to major impacts (4.3.1 and 4.3.2). Most of these birds would be additional numbers of the same species, but would also include a few scavengers and predators such as ravens and raptors who attempt to feed on contaminated bird

carcasses or other food sources. Contamination of food sources is assumed to cause direct mortality. Benthic habitats of marine invertebrate prey items of sea ducks may experience relatively moderate to major effects following a large oil spill. Reduction of food sources could also reduce survival or reproductive success of birds foraging or nesting in the impact area. Lowered food intake may slow the completion of growth in young birds, the replacement of female energy reserves used during nesting, and energy storage for migration of all individuals.

Impacts to most locally breeding marine and coastal bird populations from a large spill of up to 5,100 bbl would be somewhat limited and localized because most of these species have widely dispersed breeding distributions. As to other birds, using the area at different life history stages, contamination of one or two local marine or shoreline staging, molting, resting, foraging, or other habitat areas would have more widespread impacts, because of the migratory nature of birds. The impacts would be considered less than severe, however, for many populations, with some important exceptions, because most populations are widely dispersed in similar habitat with similar prey organisms widely distributed in the region. Impacts could be more serious, however, if the few local high density breeding populations are affected, bird populations are already in decline, or an affected foraging site is important to a significant proportion of a population (e.g., Beaufort Sea coastal river delta habitat complex for staging shorebirds). If a spill reaches shoreline areas such as river deltas and/or saltmarsh, habitat effects could persist for several years, affecting additional birds. Contamination of nearshore marine waters when large numbers of staging king eiders or molting long-tailed ducks are present would be expected to potentially kill thousands of birds, which could be considered a major impact, as could impacts to colonial nesting common eider or certain shorebird populations. A large spill impacting subtidal and intertidal habitats when large numbers of any one or several species of birds are present feeding, staging or molting, would result in lethal and sublethal effects that could be widespread due to the birds' migratory nature, and severe.

Oil Spill Risk Analysis

Bird habitat resources in the Beaufort Sea and the surrounding region are represented in the OSRA model by Environmental Resource Areas (ERA)s, Land Segments (LS)s, and Grouped Land Segments (GLS)s as listed in Appendix A, Table A.1-9 and A.1-10. A summary of the highest percent chance that a large oil spill would contact bird resources within 1, 3 and 30 days during summer and winter is provided in Table 4.3.3-2.

Table 4.3.3-2. Bird Resource Areas with Highest Percent Chances of Contact by a Large Oil Spill¹

OSRA Feature Type	Highest Percent Chance Contact	Summer 1 day	Summer 3 days	Summer 30 days	Winter 1 day	Winter 3 days	Winter 30 days
Environmental Resource Area (ERA)	1-5%	78	8,72,73,96	2,5,8,65,68,69,73	78	9,72,78	8,9,68,69,71,72,73,78,96
ERA	6-19%		9,78	9,71,72,78,96	77	77	
ERA	20-<50%	77					77
ERA	≥50%		77	77			
Grouped Land Segment (GLS)	1-5%			171,182			170
GLS	6-19%			170			

Notes: ¹ Highest percent chance from any launch area at LDPI (LI) or pipeline area (PL) during summer or winter. Note that only ERAs, and GLSs with percent chances of contact ≥1 are shown.

Sources: Appendix A (Tables A.2-1 through A.2-11). Maps of ERAs, LSs, and GLSs are provided in Appendix A, Maps A-2a-1 through A-4c.

Should a large spill occur in either summer or winter, the Sagavanirktok River Delta and Foggy Island Bay is the ERA (No.77 in Table 4.3.3-2 and Appendix A) with by far the greatest vulnerability (i.e., highest percent chance of contact from a large spill, should one occur at a location at the LDPI or offshore pipeline). No other bird resource area ever experiences a greater than 14% chance (experienced by No. 72 according to the OSRA: Gwyder Bay, West Dock, Cottle and Return Islands

30 days after a summer launch, see Table A.2-4) of large oil spill contact at any time. The Sagavanirktok River Delta and Foggy Island Bay ERA experiences up to a 43% chance of contact within a day, should a large spill occur, in the summer, up to a 60% chance within 3 days, leveling out at a 68% chance within 90 days in the summer. "Summer" for the OSRA is defined as July 1–September 30, and therefore includes the majority of the peak period of shorebird migration staging on the Sagavanirktok River Delta (Kendall et al., 2011; Taylor et al., 2010). Species at risk of impacts from a large oil spill at that time would include, but not be limited to, dunlin, American golden-plover, black-bellied plover, long-billed dowitcher, pectoral sandpiper, ruddy turnstone, semipalmated plover, stilt sandpiper. As the percent chance of contact rises slightly to areas along the Beaufort Sea coast to the west and barrier islands out to the north, northwest, and slightly east, vulnerability to contact may increase for some species such as Baird's and buff-breasted sandpipers and sanderling (Taylor et al., 2010).

The chance that a large spill would extend west of Point Barrow is limited. There is only up to a 2% chance that contact with the eastern boundary of GLS No. 124 (the Chukchi Sea Nearshore important bird area, or IBA), where it extends east of Point Barrow parallel with Barrow Canyon (Table A.2-4 and Map A-2f) could occur within 90 days, should a large spill occur in summer. Even after 360 days, no further west progression is estimated to occur with a >1% chance. Large spills are not estimated to travel eastward in summer or winter far beyond Stockton Islands or Mikkelson Bay with >1% chance.

Spill Preparedness and Response Activities

Spill clean-up operations can also impact birds. Birds present in or near oil affected habitats may be disturbed or displaced during spill cleanup operations (Andres, 1997; Harwell and Gentile, 2006; Jenssen, 1994). Mechanical recovery, in situ burning, or other spill response activities that take place in nearshore, intertidal, or coastal environments may displace birds from important habitats in the immediate or adjacent area, which could result in reduced reproductive success or survival, depending on the nature of those habitats (e.g., nesting, molting, staging). Impacts from oil spills and cleanup operations would be influenced by time of year. None of the conditional or combined probabilities factor in the effectiveness of oil-spill-response activities to large spills, which may range from highly effective under ideal conditions to less effective during unfavorable or broken-ice conditions.

In marine waters, birds are likely to move away from mechanical recovery and in situ burning operations, similar to moving away from other vessels, and in off-shore waters this is likely to have negligible effects. It is possible that an exception to this may occur in heavy ice conditions if birds were sheltering in an open-water lead of limited area where response activities were occurring, although impacts to bird populations from such response efforts would still be expected to be short-term and localized. Spill drills conducted by the government (government initiated unannounced exercises, or GIUE) would be infrequent and localized and are expected to contribute negligible impacts to birds.

Spill cleanup in coastal areas or on barrier islands may cause disturbance effects if it occurs while waterbirds are nesting, brood-rearing, molting, or staging for migration, or juveniles are occupying coastal habitats. Predators may take some eggs or young while adults are displaced off their nests, and birds disturbed often during this activity may have lowered reproductive success or survival. Camouflaged nests in coastal habitats could be inadvertently crushed by cleanup workers. Few high density nesting areas occur in the Proposed Action Area, but a few locally important breeding populations such as common eider (increasingly susceptible to rising sea levels and storms) may be disproportionately susceptible to nest disturbance or destruction. The duration of cleanup activities may preclude birds from using an area for an entire season. Displacement or nest destruction could disrupt a year's productivity, although some breeding birds have been shown to recover quickly in subsequent seasons (Andres, 1993). Mechanical and physical means of oil spill response are expected to contribute minor to moderate impacts to invertebrates and fish (Sections 4.3.1 and 4.3.2). Some of

these prey populations may be locally important bird food resources for a few bird species but may take a few years to completely recover.

In summary, oil spill response activities that include mechanical recovery and other physical presence and in situ burning, and occur in the nearshore, intertidal, or coastal environments, would be expected to have minor impacts, and slightly increase the moderate and major impacts expected from an oil spill. The highest impacts (i.e., a major level of impact for large spill and spill response activity combined) would be expected to occur to those birds such as common eider that may survive initial spill impacts but have nesting efforts impacted in a subsequent clean-up season. Such impacts could be long-lasting for Central Beaufort Sea populations that may be heavily impacted in successive breeding seasons.

ESA-Listed Species

Spectacled eiders commonly forage off the Sagavanirktok River Delta and in Foggy Bay. Spectacled eiders nest on the Proposed Action Area tundra in very low densities. A large spill from the LDPI or the offshore pipeline would have the highest probability of contacting nearshore and offshore areas of Foggy Island Bay and the Sagavanirktok River Delta, where spectacled eiders may be staging in open waters in spring following migration, or foraging throughout the area post-breeding prior to fall migration. Oil could contact these eiders from early June to September. Stehn and Platte (2002) found that a very low number and percentage of the total ACP spectacled eider population would be exposed to a large spill originating in this area. While the modelling, spill trajectories, and exact spill volumes differ from the current OSRA, a low level of impact on spectacled eider is still expected. This is because the earlier finding was based primarily on the low abundance of the species on the central Beaufort Sea coast, and the species' generally widespread distribution, which would prevent a large percentage of the population from being contacted by the spill. These factors remain true for the species.

One oil spill not exceeding 5,100 bbl could cause a few deaths among nesting, brood-rearing, or staging spectacled eiders. Depending on location, benthic resources may incur moderate or major impacts (with Boulder Patch resources among the latter) (4.3.1). Reduction of prey populations from a spill could have a negative effect on the foraging success of breeding or staging spectacled eiders, especially in spring when there is limited open water. Spectacled eiders do not occur in high densities in the vicinity of the Proposed Action Area but numbers up to the low tens could be directly impacted by a large spill. Spill-cleanup activities may disturb brood-rearing or staging eiders occupying coastal habitats, resulting in decreased survival. Because eiders tend to be somewhat dispersed with limited flock size and, because of the area in which oil from a large spill is most likely to stay somewhat confined, impacts over two years' clean-up season may impact tens of eiders or more. Impacts of this size from a large spill and spill clean-up efforts on spectacled eider could be considered widespread, and therefore moderate, particularly if Canadian breeders will be affected while staging in the area.

With limited abundance and low chance of contact to areas used by threatened Steller's eider, this species is expected to incur negligible impacts from small and large oil spills associated with the Proposed Action.

Conclusion: Oil Spills

While spills can occur on land, spills in the marine environment have the greatest potential to affect large numbers of birds, including listed birds, because of their ability to spread and persist in aquatic (including shoreline) environments. Exposure of listed spectacled eiders and other marine and coastal birds is expected to result in the general effects summarized below. This analysis assumes that all birds contacted by oil would not survive and that secondary effects may cause impaired physiological function and production of fewer young.

If a large spill were to occur, it would have the highest percent chance of contacting nearshore and offshore areas of Foggy Island Bay and the Sagavanirktok River Delta, where, depending on spill timing, waterfowl and other aquatic birds may be molting, staging before migration, or pausing during migration. The number of birds that could be lost depends considerably on the timing. Birds are absent from the marine environment in winter, and largely from the terrestrial environment as well. A spill in July or August, however, could impact hundreds or thousands of long-tailed ducks and king eiders, hundreds of glaucous gulls, common eiders, and scoters, and a number of loons and other waterbirds.

Perhaps at greatest risk in terms of numbers of birds directly contacted would be several thousand shorebirds comprised of several species on the Sagavanirktok River Delta or other coastal mudflats during peak fall migration staging, and the rapid turnover of migrants during this period suggests that many more could be exposed. This could result in population-level, or major, effects to one or two species. Some of the several hundred brood-rearing, molting, or staging brant and snow geese could contact oil in coastal habitats. A large onshore pipeline spill in summer, however, would be unlikely to affect more than a few nests of any one species, because there are no known breeding colonies or particularly high density nesting areas in the onshore Proposed Action Area and onshore spills have a relatively lower chance of spreading. For most bird species, the relatively small losses likely to result from a spill may be difficult to separate from the natural variation in population numbers, but their populations are not expected to require lengthy recovery periods. If the reduction or contamination of food sources persists long after the spill has dispersed or been cleaned up, impacts to local populations of birds also could persist.

If a large oil spill contacted the listed population of spectacled eider or affected its benthic food source, it would be expected to have widespread, and therefore moderate impacts, depending on number of individuals impacted, how far their breeding range spanned, or temporal and areal extent of impact to food resources, due to the population's limited population size.

Based on the large number of birds that occur in the area during the summer months and the likelihood of important bird habitats being contacted, thousands of birds could be impacted as a result of the large oil spill assumed under the Proposed Action, resulting in a moderate to potentially major level of impact to some non-listed species, and a moderate level of impact to listed spectacled eider. The level of impact from spills could be increased temporarily by spill clean-up efforts, but would still remain moderate for spectacled eiders and moderate to major for non-listed species.

Overall Summary

The greatest level of direct impact from routine operations associated with the Proposed Action are expected to come from increased predator levels; disturbance from traffic; and the collision hazards associated with the physical presence of new facilities, including the proposed LDPI, onshore pipeline, and associated vessels. Moderate levels of impact would be expected from increases in predator abundance, because the increases would be long-term, and the effects on nesting populations, while originally somewhat localized, would also be on-going and long-term.

The bright artificial lighting of the LDPI (i.e., ambient and occasional gas flaring) and some vessels (e.g., assist tug) would cause attractions, disorientations, and indirect effects via exhaustion and increased levels of collisions when certain environmental conditions are present during migration. Certain declining population or limited-population species, including buff-breasted sandpiper are among those of the many species at risk of collision. The long-term presence (i.e., life of the Proposed Action) of these facilities and the assist tug means that these collision hazards would be on-going, although are not expected to cause impacts substantial enough, relative to most species' abundances, to be considered more than minor. Collision hazards associated with the Proposed Action present as high as a long-lasting and moderate level of impact for listed spectacled eider, however, due to the

vulnerability of this species' low population coupled with the vulnerability of eiders to collision hazards.

Minor levels of impact are expected from most traffic disturbances. Aircraft traffic, given that low-level flights are only infrequently part of the Proposed Action, may also have a minor level of disturbance impact except for current direct routing that could take them across sensitive areas like nesting colonies. Such routing is expected to mean a moderate level of impact without mitigation. Birds generally move away from localized sources of disturbance. Other sources of disturbance are not anticipated to occur in areas uniquely important to birds (e.g., vessel disturbance of barrier-island nesters).

The impacts of terrestrial habitat alteration are expected to range up to minor. The permanent loss of habitat and displacement from habitats would persist across seasons. However, gravel extraction and pipeline construction activities are not anticipated to occur in areas uniquely important to birds, including listed species. Acreage of habitat loss and fragmentation is small relative to amount of available habitat. Marine habitat effects are expected to be negligible to minor as turbidity would be short-term, and benthic prey would recover in most areas from sedimentation, and the amount of foraging habitat affected is negligible relative to that available.

Conclusion

Effects from the physical presence of vessels, aircraft, vehicle traffic, or drilling facilities, including mortality from birds encountering vessels and structures, and small spills, are localized and most would not persist from season to season. Habitat alteration impacts would be localized and minor. Decreased levels of productivity from higher predator abundance associated with increased human presence and infrastructure presence could result in a more widespread and long-lasting, and therefore moderate level of effect for a few vulnerable species. Added together, the activities of the Proposed Action would range from minor for most avian species to long-lasting and widespread, therefore moderate, for some vulnerable (declining and limited populations) and listed spectacled eiders.

Government initiated unannounced exercises (spill drills) would be infrequent and localized and are expected to contribute negligible impacts to birds. Impacts to birds as a result of NPDES-permitted discharges are expected to be negligible, with any potential impacts being intermittent, localized, and short-term in nature.

Alaska-breeding Steller's eiders breed almost exclusively on the ACP, but nesting is concentrated in tundra wetlands near Utqiagvik, Alaska. The probability of Alaska breeding Steller's eiders occurring in the Proposed Action Area is so low as to be discountable. Thus, the Proposed Action is likely to have a negligible level of effect on Steller's eider.

Appendix C describes mitigation measures derived from lease stipulations, design features and BMPs the operator committed to, and requirements and BMPs that other agencies typically require (sections C-1 to C-3). BOEM's conclusion above of overall impacts to birds assumes implementation of, and compliance with, the mitigation measures described in sections C-1 through C-3.

The effects of the Proposed Action on birds may be modified by application of potential mitigation measures, as discussed above and described in Appendix C (section C-4).

4.3.3.2. Alternative 2 – No Action

Under this Alternative, the Proposed Action would not be approved and the actions described in the 2015 Liberty DPP would not take place. Impacts from the Proposed Action on birds, including listed species, from traffic or equipment operations disturbances, habitat alterations, collisions, increased predator abundance, oil spills or spill response associated with the development of the 2015 Liberty DPP would not occur. Consequently, selection of Alternative 2 would result in no impact to birds, including listed species.

4.3.3.3. Alternative 3 – Alternate Location for proposed LDPI

Alternative 3A: Relocate the proposed LDPI approximately one mile to the east to reduce sedimentation impacts on the Boulder Patch during construction/installation period.

This alternative would require (relative to the Proposed Action and impacts to birds) longer drilling time, a small amount more gravel mined, a negligible increase in seabed footprint, longer ice road, and more vehicle travel time, including potentially summer travel. Taken together, these aspects would be expected to increase effects to birds, primarily through disturbances and potentially increased number of small spills associated with lengthened drilling and travel time. These additional disturbance and small spill impacts would be localized and temporary, and therefore the increase would be expected to be relatively small. Nesting and brooding listed spectacled eider would be among those tundra-nesting birds affected. Spectacled eider local nesting density is relatively low, however, so increase in impacts should be minimal. In summary, the combined impact of routine activities associated with Alternative 3A on listed and non-listed birds would be moderate, although slightly increased above that of the Proposed Action. The moderate level of impact is primarily due to increased predator abundance that remains as described for the Proposed Action. While the discharge location would change (See Section 2.2.4.1), the overall impacts to birds as a result of NPDES-permitted discharges under Alternative 3A would be the same as the Proposed Action, which is negligible.

Alternative 3B: Relocate proposed LDPI approximately 1.5 miles to the southwest (closer to shore) to reduce sedimentation impacts on the Boulder Patch during construction/installation period.

This alternative substantially increases the drilling time (between 2-3x longer), and requires a larger drill rig, less gravel, and a slightly smaller seabed footprint. A slight increase in the effects to birds, including both listed and non-listed species, may be expected, primarily because of a temporary increase in collision risk from the larger drill rig and increased length of drill rig presence. Unless the increased drilling time results in the drill rig being physically present as a collision hazard for a season or more, including months of low visibility during migration, that it would be under normal operations planned for the Proposed Action, the increase may be negligible. This Alternative is expected to result in a somewhat lowered level of effect on Boulder Patch organisms, which can be prey sources for marine birds. These differing levels for lower trophic resources are not substantial, however, especially given the relative alternative availability of benthic forage habitat for birds. The level of impact for routine activities associated with Alternative 3B, overall, is expected to be similar to that of the Proposed Action, i.e., moderate. While the discharge location and permitting jurisdiction would change (See Section 2.2.4.1), the overall impacts to birds as a result of NPDES-permitted discharges under Alternative 3B would be the same as the Proposed Action, which is negligible.

4.3.3.4. Alternative 4 - Alternate Processing Locations

For both options of Alternative 4, the small differences in habitat alteration (i.e., less gravel mined and used for the LDPI) as compared to the Proposed Action would result in a negligible difference in impacts to birds. Other differences, however, have more significance and are explained below. Impacts to birds as a result of NPDES-permitted discharges under Alternatives 4A and 4B are the same as those for the Proposed Action, which is negligible.

Alternative 4A: Relocate Oil and Gas Processing to Endicott

This alternative would potentially cause less vessel and air traffic disturbance, because less vessel and air traffic may be needed between Endicott and the proposed LDPI, although the difference in traffic is not clear and the differences in disturbance, both temporary (i.e., during construction) and long-term, may be slight. More vehicle travel and usage of gravel roads in all seasons and for the life of the

Proposed Action may also be expected, which could increase vehicle traffic effects on both listed and non-listed species. Overall, routine activities associated with Alternative 4A may have a similar impact level to that of the Proposed Action, i.e., moderate.

Alternative 4B: Relocate Oil and Gas Processing to a New Onshore Facility

This alternative would be expected to have increased levels of impact on birds, because one of the greatest expected sources of impact, a large new lighted facility that is an attraction and collision hazard in an otherwise dark landscape where tens of thousands birds migrate, would be doubled with the addition of another new processing facility (plus the new LDPI). The additional few acres of terrestrial habitat loss and disturbance for the new onshore facility would affect numerous species of breeding birds, but the numbers of breeding territories lost would be negligible relative to overall population numbers. Permanent fragmentation of coastal habitat, while fairly localized, may occur however, and this may become more pronounced over the life of the Proposed Action as coastal erosion is expected to occur (see Section 3.1.6). Increased chronic disturbance and long-lasting effects of predator abundance would also be expected from increased onshore human presence and the presence of a new onshore pad and facilities. Collectively, the potential impacts of routine activities associated with Alternative 4B would be numerous, substantial, and long-lasting. While none of the avian populations at risk of impact are currently critically imperiled, it is possible that over the life of the Proposed Action a changing environmental baseline would result in further declines to already declining vulnerable populations (e.g., listed spectacled eiders, non-listed shorebirds). While the impacts would likely remain less than severe, because the avian populations are not expected to depend entirely on the Proposed Action Area for any life phase, the expected moderate level of impact would be distinctly greater, however, than that of the Proposed Action.

4.3.3.5. Alternative 5 - Alternate Gravel Sources

Alternative 5A: East Kadleroshilik River Mine Site #2

This site would require a 40% longer roundtrip gravel haul by truck, including a Kadleroshilik River crossing. Thousands of gravel truck hauls are required for the construction of the pads and LDPI, and most occur in the winter or spring when flightless birds are not present. Nonetheless, many may still occur after some birds have arrived in the spring, and the increased trip length also means increased areas for small spills to potentially occur, and, potentially, more small spills. The site is located about 0.5 mi from a previously identified Kadleroshilik River buff-breasted sandpiper lek, an important breeding feature and a bird of limited population size. This species' leks, however, are likely to be highly transitory in location (R. Lanctot, pers. comm., 2016), are not closely adjacent to nests, and the Alternative 5A mine site is primarily different habitat types than the previous lek site on the river's gravel bars. Increased impacts to birds and their habitats may be expected, primarily from the increased trip lengths, but routine activities associated with Alternative 5A would be expected to remain within moderate levels.

Alternative 5B: East Kadleroshilik River Mine Site #3

This site would require a 50% longer roundtrip gravel haul by truck, including a Kadleroshilik River crossing. Thousands of gravel truck hauls are required for pad and LDPI construction, and most would occur in the winter or spring when flightless birds are not present. Nonetheless, many may still occur after some birds have arrived in the spring, and the increased trip length also means increased areas for small spills to potentially occur, and, potentially, more small spills. These disturbance impacts would be limited to one year, however, and therefore routine activities associated with Alternative 5B would be expected to remain within moderate levels. As with the Proposed Action, Alternative 5B may have a major level of impact when oil spill hazards are considered.

Alternative 5C: Duck Island Mine Site

At 42 miles from the proposed LDPI, this alternative would require a very substantial increase in roundtrip gravel haul trip distances over the 10-mile distance of the Proposed Action's gravel mine site. Because of the distance, the time period of vehicle disturbances may be doubled, to four seasons. The increased distance and time means more habitat in which displacement effects and small spills could occur, and more birds that could incur disturbance effects to their foraging, nesting, and breeding. Although less localized than the areas of potential disturbance associated with the other Action Alternatives, these increased gravel haul disturbance impacts would be limited to four years, and therefore considered relatively short-term. Routine activities associated with Alternative 5C would be expected to remain within moderate levels.

4.3.4. Marine Mammals

Underwater Noise

The following general information about impacts to marine mammals from underwater noise is provided for context and to inform the project-specific impact analysis.

Marine mammals use sound, sight, olfaction (smell), and somatic (orientation of the body) senses to interact with their environment. Anthropogenic (human made) sound can affect marine mammals in a number of ways including:

- Behavior disruption
- Sound masking
- Hearing loss
- Physiological stress or injury
- Ecosystem changes

Marine mammal ability to detect and generate sound may vary greatly between species based on differences in sound characteristics such as frequency, bandwidth, energy, directionality, and temporal patterns. Furthermore, oceans are naturally noisy, with a variety of sounds which marine mammals must be able to perceive and sort with precision. The frequency bands and source levels of industry-related sounds and the hearing frequencies of Arctic marine mammal groups are depicted in Figure 4.3.4-1.

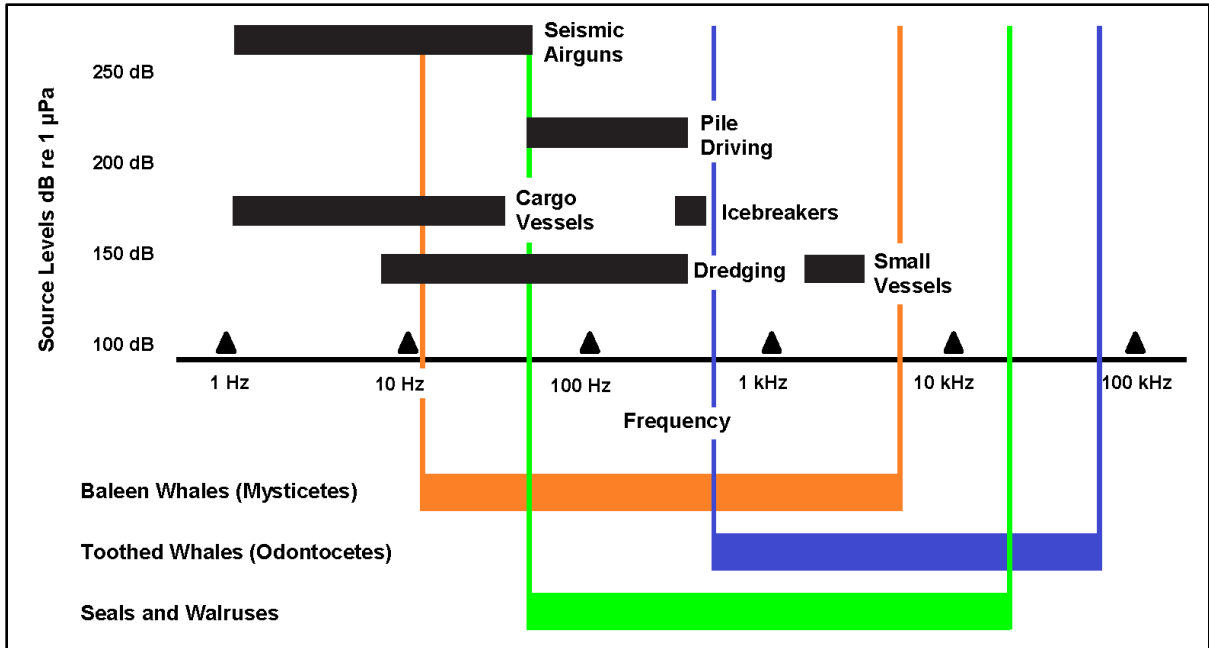

Figure 4.3.4-1. Frequency Bands and Source Levels for Common Arctic Offshore Activities. *Source: Moore et al., 2012; Greene, 1995.*

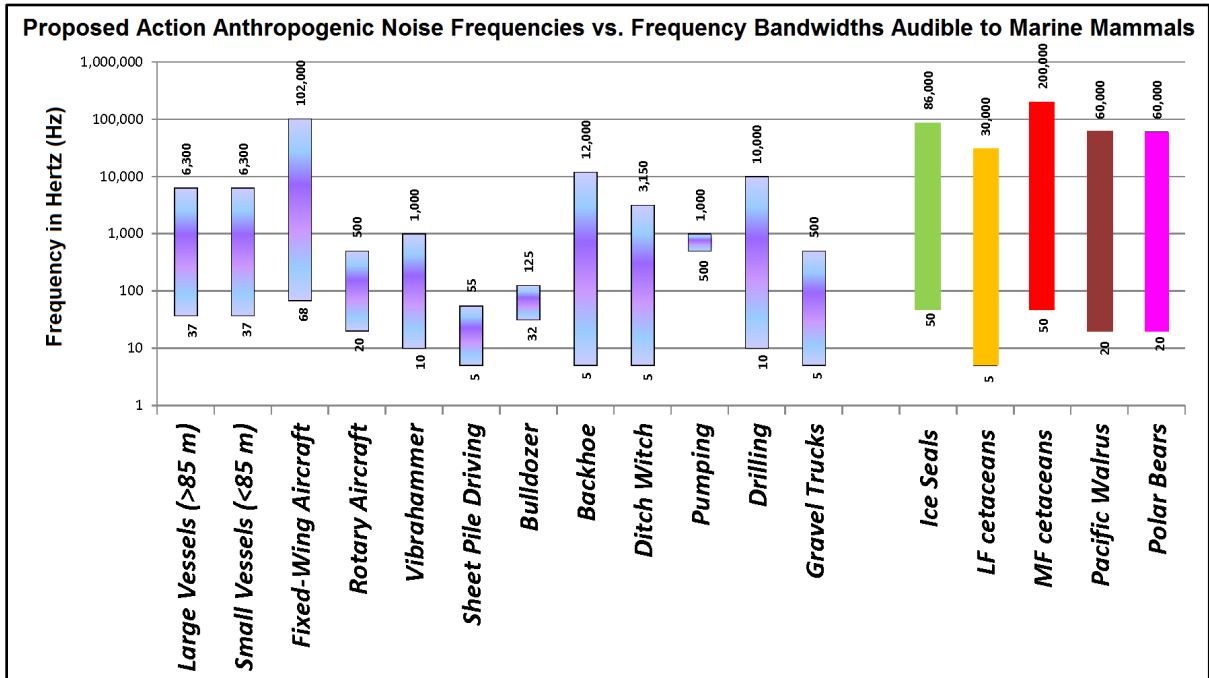

Figure 4.3.4-2. Comparing Marine Mammal Hearing to Proposed Action Noises. *Sources: Hilcorp, 2015; Ciminello et al., 2012; Greene et al., 2008; Blackwell and Green, 2004; and Blackwell and Green, 2004; Green and Moore, 1995; NMFS, 2016.*

Figure 4.3.4-2 indicates, for example, that species such as the Pacific walrus (brown bar, second from right) have little auditory overlap between the sound frequencies they hear and the sound frequencies produced by sheet pile driving or bulldozers. Understanding such relationships between marine mammals and anthropogenic sound is crucial when analyzing the potential of noise to affect any specific species of marine mammal.

The data in Figure 4.3.4-2 are analyzed in Moore et al. (2012), taking data from Greene (1995), and show the frequency range considered by the U.S. Navy to be audible to seals occurring between 75 Hz–75 kHz, whereas the Navy applies a 100 Hz–50 kHz frequency range to Pacific walrus and polar bears (Finneran and Jenkins, 2012).

Table 4.3.4-1 summarizes the known boxcar, or upper and lower hearing ranges, of several marine mammal species.

Table 4.3.4-1. Marine Mammal Boxcar Frequency Range.

Species Group	Lower Limit (Hz)	Upper Limit (Hz)
LF Cetaceans (Bowhead and Gray Whales)	7	35,000
MF Cetaceans (Beluga Whales)	150	160,000
Walrus, Polar Bears (in water)	60	39,000
Bearded, Ringed, and Spotted Seals (in water)	50	86,000

Note: Comparison was made using the Navy Acoustic Effects Model.

Source: NMFS, 2016a

In order to more effectively analyze the impacts of noise on the various marine mammals, the actual hearing capabilities of each species group must be considered. The low-frequency hearing group of cetaceans that includes the mysticetes whales has a hearing range between 7 Hz – 35 kHz (NMFS 2016a) (Table 4.3.4 1). Mid-frequency cetaceans, which includes beluga whales, hear sound in the 150 Hz – 160 kHz range; the frequency range audible to seals occurs between 50 Hz – 86 kHz. The different marine mammal species would be affected to differing degrees by the noise associated with the Proposed Action.

Tables 4.3.4-2 and 4.3.4-3 illustrate how NMFS (2016a) modified the Finneran (2015 and 2016) analysis of continuous and impulse noise that can lead to either permanent or temporary threshold shifts (see definitions below the Table) in hearing. NMFS (2016) uses of Sound Exposure Levels (SEL) over a 24 hour period, as the preferred assessment tool for injury to marine mammals from non-impulsive noise (Table 4.3.4-2).

Table 4.3.4-2. Non-Impulsive Noise Thresholds and Criteria for Beaufort Sea Marine Mammals.

Group	Species	PTS Onset	TTS Onset
LF Cetaceans	Bowhead, Gray,	199 dB SEL (Type II weighted);	179 dB SEL (Type II weighted)
MF Cetaceans	Beluga Whales	198 dB SEL (Type II weighted);	178 dB SEL (Type II weighted)
Phocidae (in water)	Bearded, Spotted, and Ringed Seals	201 dB SEL (Type I weighted);	181 dB SEL (Type 1 weighted);
Odobenidae (in water)	Pacific Walrus	219 dB SEL (Type I weighted)	199 dB SEL (Type I weighted)
Ursidae (in water)	Polar Bear	219 dB SEL (Type I weighted)	199 dB SEL (Type I weighted)

Note: Type I weighting is a baseline, while type II weighting modifies Type I to account for new data showing increased susceptibility to noise at higher frequencies.

Sources: Ciminello et al., 2012; NMFS, 2016a.

Acoustic exposures can result in three main forms of noise-induced losses in hearing sensitivity:

- **Permanent Threshold Shifts (PTS).** PTS is caused by physical damage to the sound receptors (hair cells) in the ear. Such damage produces permanent partial to total deafness within a range of audible noise frequencies.
- **Temporary Threshold Shifts (TTS).** TTS has been studied by determining the impact on sound receptors (hair cell damage). Because hair cell damage does not occur in a TTS, hearing losses are temporary with recovery periods that can last minutes, days, or weeks. Kujawa and Liberman (2009) reported noise-induced degeneration of the cochlear nerve that was a delayed result of TTS producing acoustic exposures. Those exposures produced TTS states for the subject animals that occurred in the absence of hair cell damage, but was irreversible. They concluded the reversibility of noise induced threshold shifts, or TTS, can disguise progressive neuropathology that would have long-term consequences on an animal's ability to process

acoustic information. If this phenomenon occurs in a wide range of species, TTS may have more permanent effects on an animal's hearing sensitivity than earlier studies suggest.

- **Compound Threshold Shift (CTS).** CTS occurs when some loss in hearing sensitivity is permanent and some is temporary. For example, there might be a permanent loss of hearing sensitivity at some frequencies and a temporary loss at other frequencies or a loss of hearing sensitivity followed by partial recovery.

Table 4.3.4-3. Impulse Noise Criteria and Thresholds for Marine Mammals.

Group	Species	Onset PTS	Onset TTS
LF Cetaceans	Bowhead, Gray Whales	183 dB SEL (Type II weighted) or 219 dB Peak SPL	168 dB SEL (Type II weighted) or 213 dB Peak SPL
MF Cetaceans	Beluga	185 dB SEL (Type II weighted) or 230 dB Peak SPL	170 dB SEL (Type II weighted) or 224 dB peak SPL
Phocidae (in water)	Bearded, Spotted, Ringed Seals	185 dB SEL (Type I weighted) or 218 dB Peak SPL	170 dB SEL (Type I weighted) or 212 dB Peak SPL
Obodenidae Water	Pacific Walruses	203dB SEL (Type I weighted) or 232 dB Peak SPL	188 dB SEL (Type I weighted) or 226 dB Peak SPL
Ursidae Water	Polar Bears	203 dB SEL (Type I weighted) or 232 dB Peak SPL	188 dB SEL (Type I weighted) or 226 dB Peak SPL

Notes: 1: = $91.4M^{1/3}(1+[DRM/10.081])^{1/2}$ Pa-sec, where M = mass of animals in kg and DRM = depth of receiver (animal) in meters.
 2: = $39.1M^{1/3}(1+[DRM/10.081])^{1/2}$ Pa-sec, where M=mass of animals in kg and DRM = depth of receiver (animal) in meters.
 3: RMS refers to 90% of the energy under the envelope (where "envelope" refers to the boundaries delineated by the noise threshold), per NMFS OPR.
 4: Ciminello et al. (2012) identifies 190 dB as the Level A threshold for Pacific walruses; however, in its Marine Mammal Protection Act (MMPA) documents (e.g., Biological Opinion for Polar Bears and Conference Opinion for Pacific Walrus on the Chukchi Sea Incidental Take Regulations (USDOL, USFWS, 2013a)) the USFWS identifies 180 dB as the Level B harassment threshold for walruses.

Sources: Ciminello et al., 2012; NMFS, 2016a.

PTS and TTS noise effects on marine mammals are measured using Sound Exposure Level (SEL_{24}), which requires the accumulation of energy from every ping/pulse within each of four (low-, mid-, high-, and very high-) frequency bands (Ciminello et al., 2012), and impulse noise effects on marine mammals may also use the Peak Sound Pressure Level (SPL_{Peak}) metric (NMFS, 2013b; 2016a). SPL_{Peak} refers to the sound produced by a single noise source at one point in time as measured at the peak of the sound wave, whereas SEL_{24} refers to the aggregate noise from a noise source over a 24 hour period.

Though PTS and TTS may be assessed using the SEL_{24} metric, and non-impulsive noise may also be assessed using the Peak Sound Pressure Level (SPL_{Peak}) or NMFS has historically used SPL to determine harassment as defined under the MMPA.

NMFS no longer uses the 190 and 180 dB root mean square (SPL_{RMS}) to determine Level A harassment threshold for non-impulsive or impulse sound levels (Table 4.3.4-4). Such noise levels may extend 10s, 100s, or 1,000s of meters from a noise source before attenuating out, and are produced by several types of activities, many unrelated to the oil and gas industry

The 160 and 120 dB SPL_{RMS} noise levels continue to be the impacts assessment threshold for the onset of Level B harassment with respect to impulsive and non-pulsed noises respectively (Table 4.3.4-4). These noises may begin at the source, such as with drilling, construction, and pile-driving, and may propagate and attenuate out for several miles depending upon the activity and source levels (NMFS, 2013b, p. 197-198; 2016a). The threshold used for Level B harassment for continuous noise is 120 dB (NMFS, 2013b, p. 197-198; 2016a), and the threshold for Level B harassment for impulse noises is 160 dB SPL_{RMS} (NMFS 2016a; SLR, 2017). The USFWS continues to use the older seal and whale Level A and Level B harassment thresholds for polar bears and walrus, respectively (Table 4.3.4-4), with the exception of Level B threshold for non-impulsive noise, for which the agency has

not yet defined criteria for polar bears and walrus (pers comm with Christopher Putnam, USFWS, February 2016).

Acoustic Harassment Criteria

Table 4.3.4-4. NOAA Fisheries Current In-Water Acoustic Thresholds.

Criterion	Criterion Definition	Threshold
Level A	PTS (injury) conservatively based on TTS	190 dB _{rms} Polar Bears 180 dB _{rms} Pacific Walrus
Level B	Behavioral disruption for impulsive noise (e.g., impact pile driving)	160 dB _{rms} All Marine Mammals
Level B	Behavioral disruption for non-pulse noise (e.g., vibratory pile driving, drilling)	120* dB _{rms} ¹ All Marine Mammals

Notes: Thresholds exclude tactical sonar and explosives. All decibels referenced to 1 micro Pascal (re: 1µPa). All thresholds are based off root mean square (rms) levels.

*The 120 dB threshold may be slightly adjusted if background noise levels are at or above this level.

¹ At present, the USFWS has focused on thresholds for impulsive noise and has not evaluated polar bear and whale Level B thresholds for continuous noise (pers comm with Christopher Putnam, USFWS, February 2016).

Sources: NOAA Fisheries, West Coast Region Interim Sound Threshold Guidance (NMFS, 2016b); USDOl, USFWS, 2013a; NMFS, 2016a.

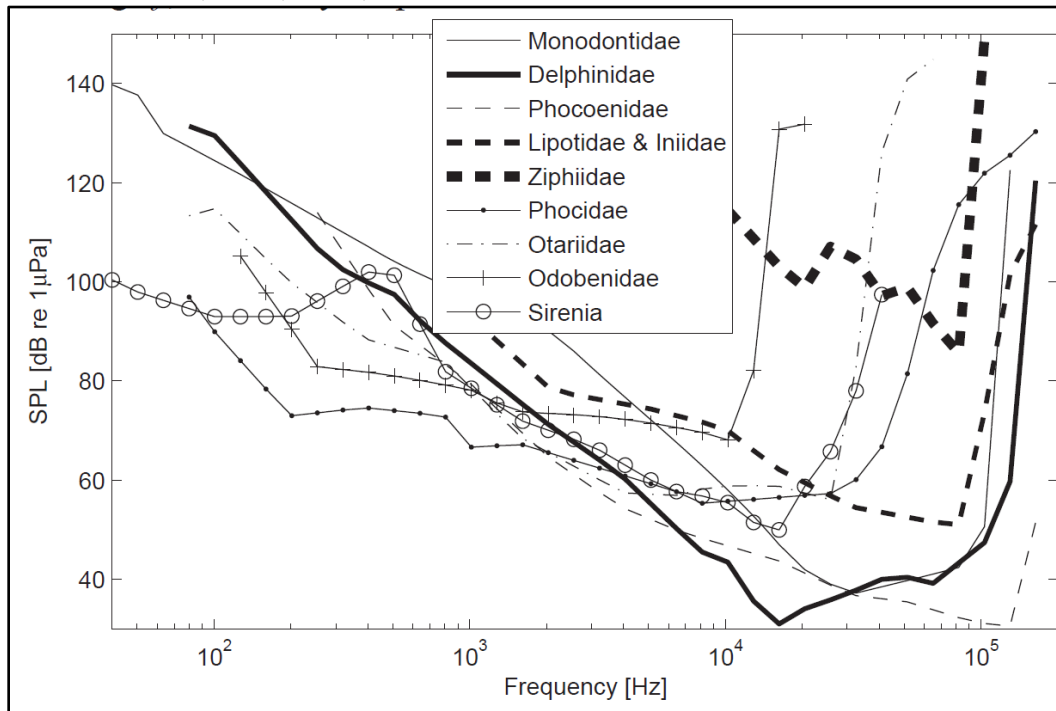

Figure 4.3.4-3. Generalized Underwater Audiograms of Marine Mammals. Figure shows the minimum thresholds over all species belonging to the same family. (JASCO Applied Sciences, 2011)

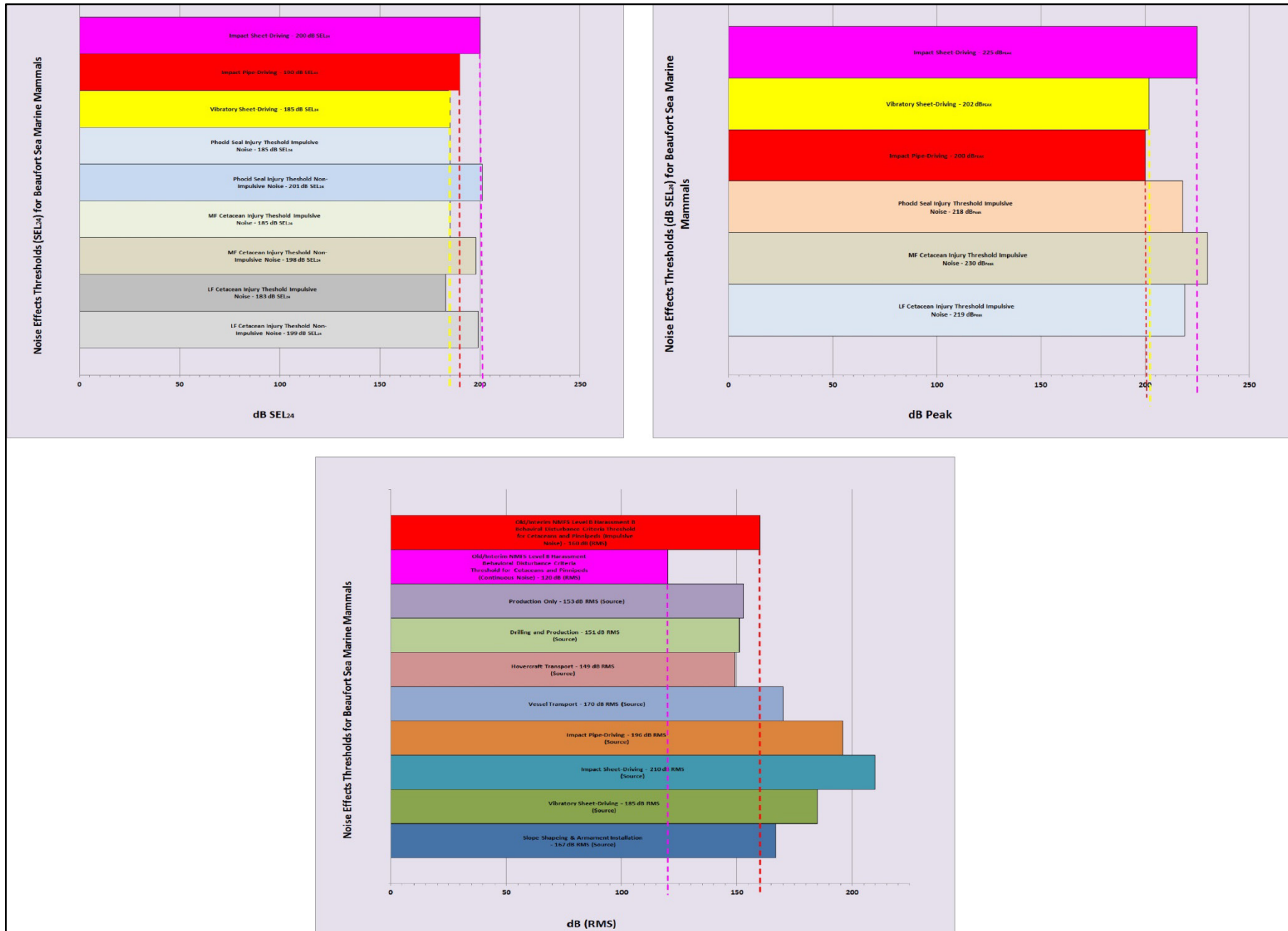

Figure 4.3.4-4. NMFS Level A and B Harassment Thresholds and Modeled Threshold Shifts. NMFS Level A and Level B harassment criteria thresholds and the modeled permanent and temporary threshold shifts (PTS/TTS) thresholds from continuous and impulse noises. For comparison, the loudest noise associated with the Proposed Action is sheet pile-driving using a vibrohammer (red dashed line) is presented along with bulldozer activity (blue dashed line), and the loudest level of ambient marine background noise (magenta dashed line). Sources: NMFS, 2016b; Finneran and Jenkins, 2012; Ciminello et al., 2012; Shepard et al., 2001; NMFS, 2016a.

Figure 4.3.4-4 compares the NMFS Level A and Level B harassment threshold criteria with the modeled PTS and TTS thresholds for marine mammals that could reasonably be expected to occur in Stefansson Sound, Alaska. It also displays an abbreviated assortment of noises (i.e., background noise, bulldozer and vibrahammer sheet-pile driving) that could occur from industry activities. Figure 4.3.4-4 also illustrates the low potential for project-related noises to elicit a TTS or PTS on any marine mammal species in the vicinity of the Proposed Action.

NMFS (2013b) and Table 4.3.4-5 below show distances from industrial continuous noise sources to median background noise levels of approximately 120 dB re 1 μ Pa, using the strongest 1/3 octave band, the noise level generally used to represent “harassment” of marine mammals under the Marine Mammal Protection Act.

Table 4.3.4-5. Distance from Development Noise to 120 dB.

Low-Frequency Noise Source	Distance to Median Background Levels Behavioral Threshold in Open Water
LDPI Drilling & Production	0.085 km / 0.05 mi
Gravel Trucks	3.26 km/2.03 mi
Vibratory Sheet Pile Driving	17.5km / 10.9 mi
Impact Sheet Pile Driving	2.25 km/1.4 mi
Impact Pipe Driving	0.4 km/0.25 mi
Dredging	25 km / 15.53 mi
Support Vessel (barge)	2.2 km / 1.37 mi
Support Vessel (tug)	1.02 km / 0.63 mi
Support Vessel (crew)	0.32 km / 0.2 mi
Hovercraft	0.095 km / 0.06 mi
General Slope Shaping, Armament Installation	1.26 km / 0.78 mi
Bulldozer	1.16 km/0.72 mi/
Augering	1.7 km/1.06 mi
Pumping	1.83km/1.14 mi
Backhoe	3.28 km/2.04 mi
Ditch Witch	7.29 km/4.53 mi

Note: Distance From Low-frequency Noise Sources to 120 dB re 1 μ Pa (ambient) Noise Levels Data.

Source: NMFS, 2013b.

The values reported in Greene (1998) are consistent with measurements collected during acoustic monitoring of a seismic survey near the Liberty Development in the summer of 2008, which yielded ambient sound levels at frequencies from 10 to 450 Hz with 5th and 95th percentile levels of 70 and 100 dB re 1 μ Pa, respectively (Aerts et al., 2008). These results are consistent with similar sound measurements in the vicinity of Northstar Island, between 2001 and 2003 (Blackwell and Greene 2006).

Shallow-water environments act as waveguides that support long-range modal sound propagation, except at low frequencies where the sound wavelength is greater than water depth. These low frequency sounds are strongly attenuated in the seafloor. The proposed Liberty Development and Production Island (LDPI) is located in shallow water, approximately 19 feet deep, which inhibits long-range propagation of sound energy below a mode-cutoff frequency of approximately 160 Hz (Urick, 1983, p. 175; Katlai et al., 2009). This cutoff frequency increases in shallower water. Consequently, much of the produced low-frequency noise below 160 Hz would attenuate in the shallow water and seabed. Since water depths at Northstar (40 feet) are deeper than at Liberty (19 feet), low-frequency sound propagates farther at Northstar. Therefore, sound propagation ranges

measured at Northstar are very conservative estimates of the expected sound footprint at the Liberty Site.

Geohazard surveys

Sonar noise occurs at higher frequencies that lie beyond the hearing capabilities of some marine mammals. For example, pinnipeds generally hear noises in the 75 Hz–75 kHz range; some sonar, such as sidescan sonar, occur in the 100-1600 kHz range, which is beyond the hearing range of pinnipeds.

- **Sidescan Sonar**

Side scan sonar is a sideward-looking, narrow-beam instrument that emits a sound pulse and “listens” for its return. The side scan sonar can be a two channel or multichannel system with single frequency monotonic or multiple frequency Compressed High Intensity Radar Pulse (CHIRP) sonar acoustic signals. The frequency of individual side scan sonars can range from 100 to 1600 kHz with source levels between 194 and 249 dB re 1 μ Pa at 1 m (rms). Pulse lengths would vary according to the specific system: monotonic systems range between 0.125 and 200 milliseconds (ms) and CHIRP systems range between 400 and 20,000 ms (HydroSurveys, 2008; Dorst, 2010). Noises in the frequency range used by sonar should be inaudible to many marine mammals with low-frequency hearing, but audible to marine mammals that hear in the mid-frequency to high-frequency sound spectrum, such as harbor porpoises and killer whales. Effects of sonar noise on marine mammals in the Proposed Action Area could involve negligible levels of effect, behavioral effects, or physiological effects, depending on the species.

- **Echosounder**

Echosounders measure the time it takes for sound to travel from a transducer to the seafloor and back to a receiver. The travel time is converted to a depth value by multiplying it by the sound velocity of the water column. Single beam echosounders measure the distance of a vertical beam below the transducer. The frequency of individual single beam echosounders can range from 3.5 to 1,000 kHz with source levels between 192 to 205 dB re 1 μ Pa at 1 m (rms) (Koomans, 2009). Multibeam echosounders emit sound to both sides of the transducer with frequencies between 180 and 500 kHz and source levels between 216 and 242 dB re 1 μ Pa at 1 m (rms) (Hammerstad, 2005; HydroSurveys, 2010). Multi-beam and single-beam echosounder noise should be audible to marine mammals that hear in low-, mid-, and high-frequency sound spectrums. Depending upon the species, there could be no effects, avoidance behavior, or physiological effects.

- **High Resolution Profilers**

High-resolution seismic reflection profilers, including subbottom profilers, boomers, and bubblepulsers, consist of an electromechanical transducer that sends a sound pulse down to the seafloor. Sparkers discharge an electrical pulse in seawater to generate an acoustic pulse. The energy reflects back from the shallow geological layers to a receiver on the subbottom profiler or a small single channel streamer. Such systems range in frequency from 0.2 to 200 kHz, with source levels between 200 and 250 dB re 1 μ Pa at 1 m (rms) (Laban et al., 2009; Greene and Moore, 1995). High resolution profiler noise should be audible to marine mammals that hear in low-, mid-, and high-frequency sound spectrums and may have no effects, cause avoidance behavior or physiological effects, with the effects varying by species.

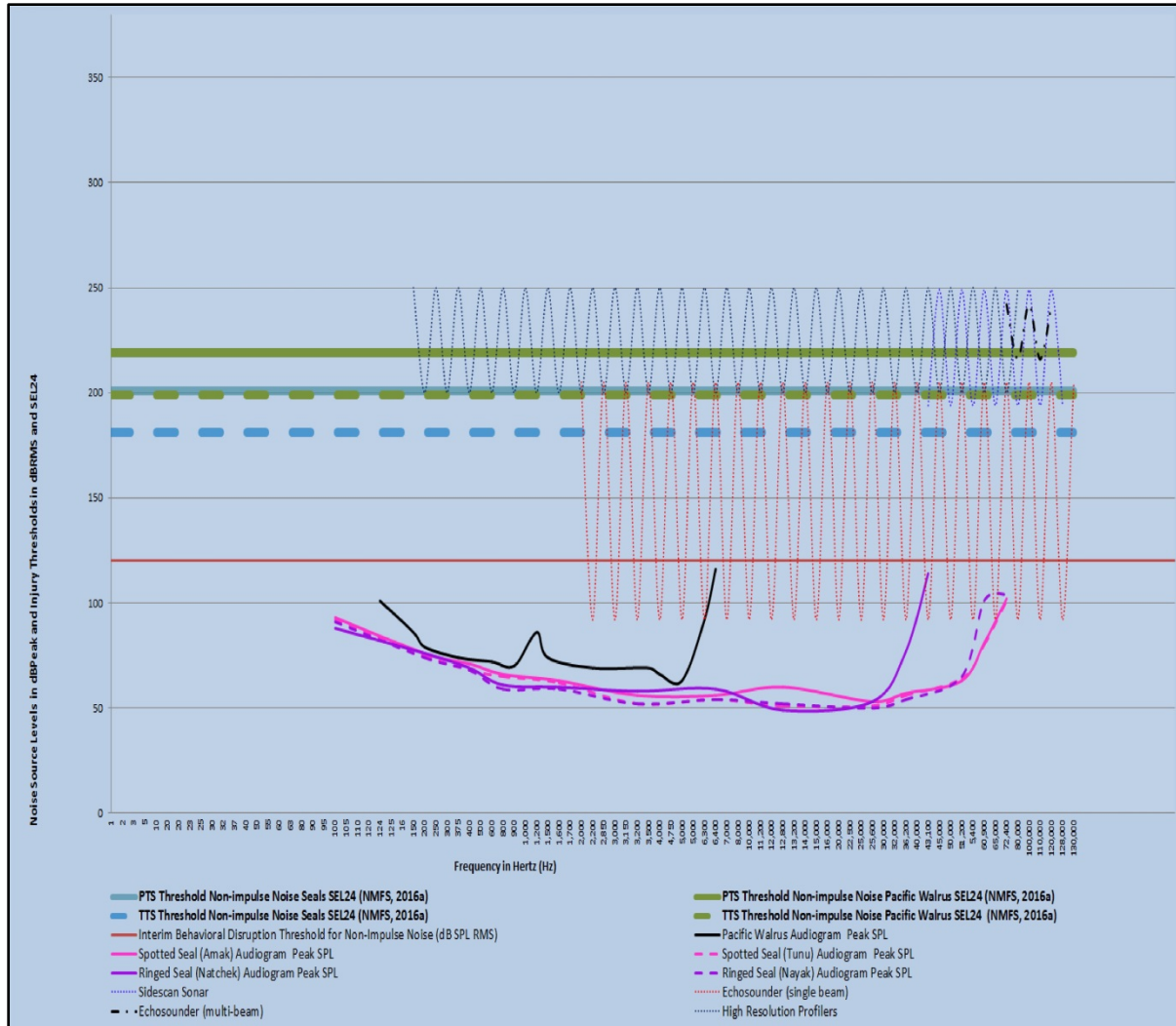

Figure 4.3.4-5. Relationship between geohazard survey noises, ringed and spotted seal and Pacific walrus audiogram and injury and behavioral disturbance thresholds. *Depicts the relationship between geohazard survey noises (dBPeak), ringed and spotted seal audiograms, and a Pacific walrus audiogram (dBPeak) (Sills Southall and Reichmuth ,2014, 2015; Kastelein et al., 2002), and their injury and behavioral disturbance thresholds (Level A and B Harassment) for pinnipeds in SEL24 and dBRMS (NMFS, 2016a).*

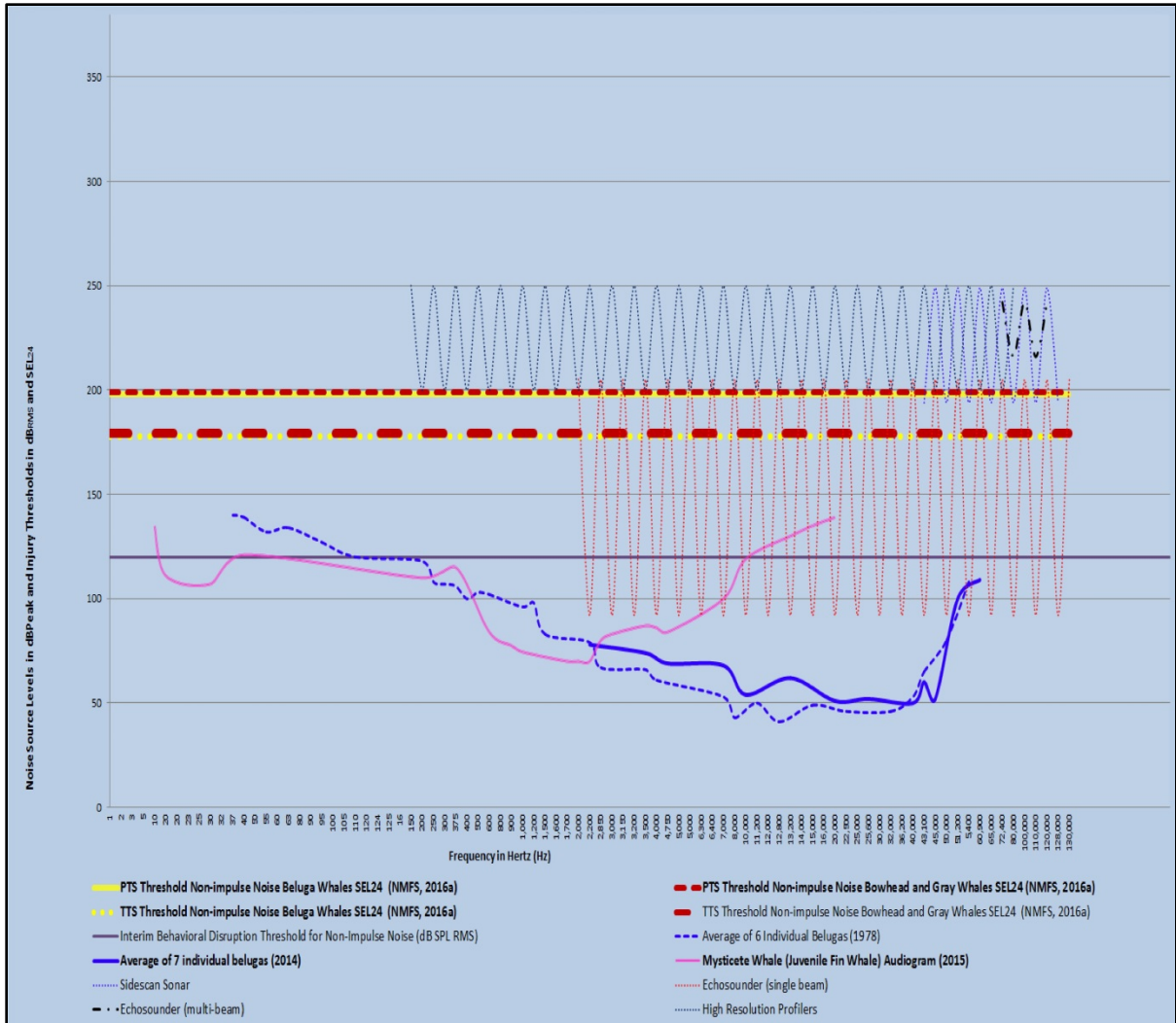

Figure 4.3.4-6. Relationship between geohazard survey noise, beluga audiograms, modeled mysticete audiogram and the NMFS injury and behavioral disturbance thresholds *Depicts the relationship between geohazard survey noises (dB_{RMS}), averaged beluga whale audiograms (dB_{RMS}) (Castellote et al., 2014; Johnson McManus and Skaar, 1989; Aubrey Thomas and Kastelein, 1988; Nedwell et al., 2004), modeled mysticete audiogram (Cranford, 2013; Cranford, 2015; Cranford and Krysl, 2015) and the NMFS injury and behavioral disturbance thresholds (Level A and B Harassment) in dB_{RMS} and SEL_{24} (NMFS, 2016a). Most survey noises occurred above the continuous noise behavioral threshold of $120\text{ }dB_{RMS}$.*

Figure 4.3.4-6 shows the dB_{RMS} to sound frequency relationship between the audible bandwidth recognized by beluga whales and a juvenile fin whale, and those of geohazard survey equipment as well. Much of the noise would be produced at levels audible to whales; with axes based on logarithmic frequency and decibel values. The modeled juvenile fin whale audiogram is used in the figure as an approximation of bowhead and gray whale audiograms that remain unavailable. Shared morphological, biological, and ecological characteristics among mysticete whales allow such substitutions to be made until such a time when audiograms for the other baleen whales become available.

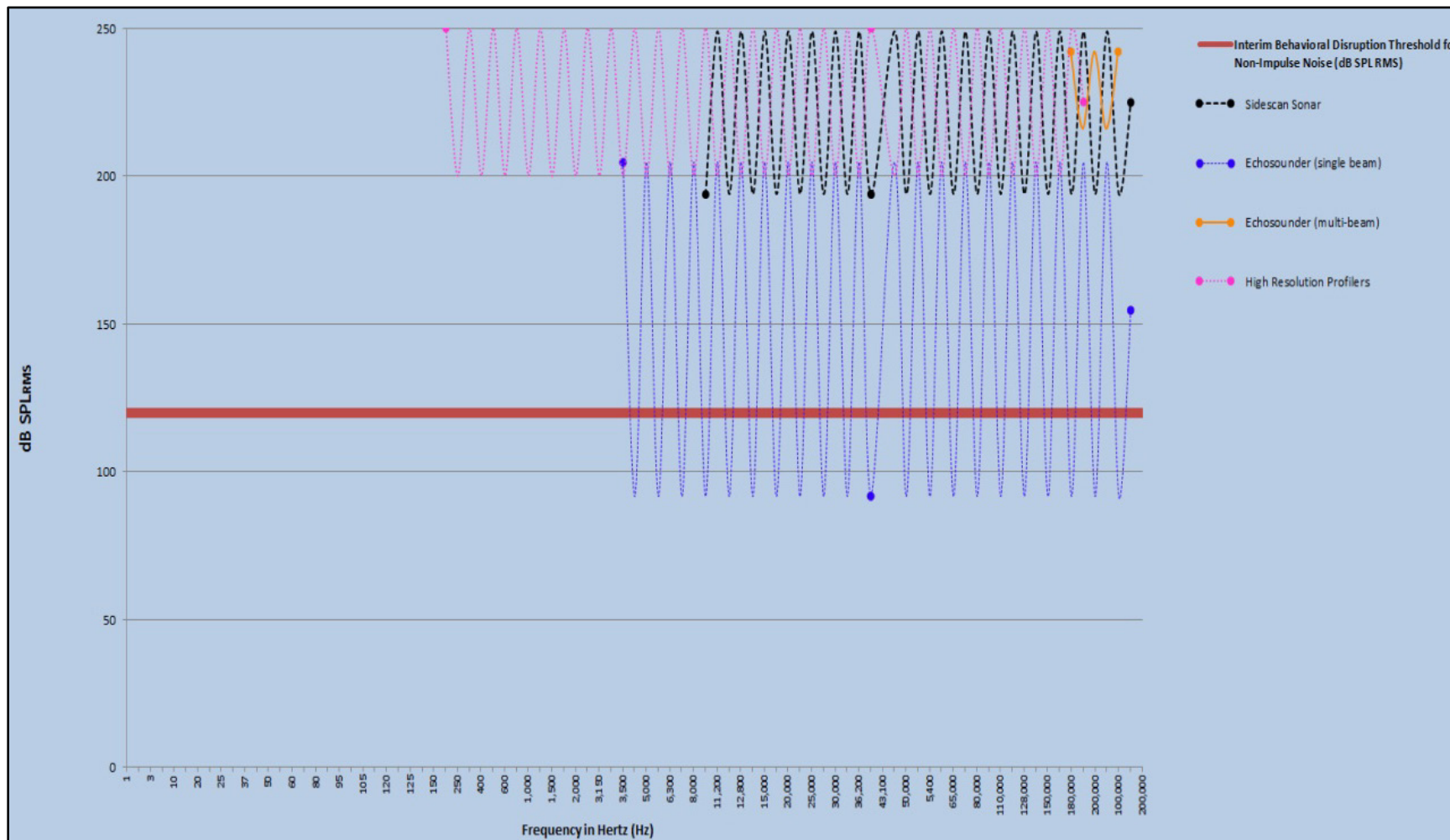

Figure 4.3.4-7. Geohazard Survey Noise and the Interim Behavioral Threshold (Level B Harassment) for Marine Mammals. *Figure portrays the relationship between geohazard survey noise and the interim behavioral threshold (Level B Harassment) for marine mammals in dB_{RMS} (NMFS, 2016a; SLR, 2017). Most survey noises would occur above the behavioral threshold of 120 dB_{RMS}.*

Figure 4.3.4-7 shows the dB_{RMS} to sound frequency relationship between the audible bandwidth recognized by beluga whales and those of geohazard survey equipment. Most noise was produced at levels audible to belugas; with axes based on logarithmic frequency and decibel values (dB_{RMS} converted to dB_{Peak}) readings.

Transportation: Vessels

Many variables contribute to whether marine mammals are likely to be disturbed by vessels, including visual presence of the vessel(s), the number of vessels in an area, the distance from a vessel, vessel speed and direction, vessel noise, vessel type or size. Other important factors include: habituation, threat association, and activity of the marine mammal.

Vessel operations would occur in the vicinity of the Liberty Proposed Action Area during the open-water season, and occasionally (2-5 trips annually during construction/1 trip every 5 years during operations) vessels may need to travel from Dutch Harbor, Alaska to offload materials at West Dock or Endicott. Such vessels operate from July to November, and introduce potential effects such as visual presence, exhaust emissions, traffic frequency, and vessel speed. Marine mammal species, mostly seals and a few belugas, may be exposed to vessels when seasonal distribution and habitat selection overlaps in time and space with proposed vessel activities in Foggy Island Bay, AK. Though a project associated vessel may occasionally travel from Dutch Harbor, Alaska to the Beaufort Sea, the mitigations described in Appendix C (C-3) would lower the potential effects discountable levels of effect (see NMFS 2013, where NMFS determined the effects of vessel traffic on marine mammals outside of the Proposed Action Area are “discountable” and did not warrant further scrutiny).

In recent years, NMFS has found vessel traffic between Dutch Harbor, Alaska and BOEM-permitted activities in the Arctic had such minimal effects on marine mammals that those effects were discountable (NMFS, 2015). With the reduced speed limit (<10 knots) HAK has committed to when traversing the North Pacific Right Whale Critical Habitat Area in the southern Bering Sea, those effects would remain so small as to be discountable as per the ESA. Since the effects of such traffic are so small as to be discountable and lacking significance, they do not warrant further discussion or analysis in this document.

Vessel Noise

Vessels associated with the Proposed Action would operate primarily during open-water and early winter periods.

Blackwell and Greene (2006) indicated that vessels were the major source of underwater noise associated with production activities at Northstar. In 2008, vessel noise at the proposed LDPI site decayed to levels of 120 dB re 1 μ Pa rms SPL within ranges less than 0.2 miles from vessels, and 100 dB re 1 μ Pa rms SPL at ranges less than 0.6 miles from vessels (Aerts et al., 2008).

Barges, a hovercraft, and other vessels would be used to transport equipment, personnel, and supplies to the LDPI during the open-water season (Hilcorp, 2015). Vessel presence and noise has the potential to disturb and temporarily displace whales from transit routes (see Section 4.3.4.1 Underwater Noise). Vessel traffic in support of the proposed LDPI construction would occur shoreward of the barrier islands, inshore of the bowhead and beluga whale migration corridor (USDOC, NMFS, 2012b) and is anticipated to reach median background levels within 0.2 mi (0.32 km) (Table 4.3.4-5).

During the open-water season, barges, a hovercraft, and other vessels would be used to transport equipment, personnel, and supplies to the LDPI (Hilcorp, 2015). Bowhead, gray, and beluga whales often tolerate the approach of slow-moving vessels within several hundred meters, especially when the vessel is not directed toward the whale and when there are no sudden changes in direction or engine speed (Heide-Jorgensen et al., 2003; Richardson et al., 1995; Wartzok et al., 1989). In

comparison, pinnipeds typically show responses to vessels such as increased alertness, diving, moving from the vessel's path by a few hundred meters, or by ignoring the vessel.

Because vessels are a predominant sound source in the U.S. Beaufort Sea (USDOC, NMFS, 2012b) and associated with existing artificial gravel island operations (e.g., Northstar, Blackwell and Greene, 2006), sound from barge-and-tug traffic could affect whales. Larger vessels produce stronger and lower frequency sounds than do smaller vessels, with dominant tones at approximately 50 Hz (Richardson et al., 1995). Tugs pulling empty barges can produce source levels of 145 to 170 dB re 1 μ Pa-m (Richardson et al., 1995, Table 6.3) and maximum sound levels from tugs at Northstar were detected 21.5 km away (Rodrigues and Ireland, 2009). While the sound source levels for barge-and-tug traffic could exceed Level B harassment thresholds, measurements taken during a seismic survey of Foggy Island Bay show that, for a vessel with a sound source level of 200 dB re 1 μ Pa-m, received sound levels reached the Level B harassment threshold for continuous noise (120 dB re 1 μ Pa, Table 4.3.4-4, Figure 4.3.4-4) 176 m from the source vessel (Aerts et al., 2008). Because vessel sounds would attenuate rapidly, particularly in shallow water, the likelihood of exposure to marine mammals is reduced.

On days with average levels of background noise at Northstar, sounds from tug boats were detectable 18.6 mi (30 km) from Northstar (Blackwell et al., 2009) (Blackwell and Greene, 2006). For clarity, detectable sound levels are not equivalent to noise levels meeting or exceeding NMFS acoustic harassment thresholds.

Small Vessels

Small vessels (<85 meters (m)) typically produce noise in frequency ranges from 37 to 6300 Hz, and 152 to 170 dB re 1 μ Pa noise levels, while small ships generally produce noise levels between 170-180 dB re 1 μ Pa in a similar frequency range (Richardson, 1995). Broadband source levels (at 1 m) for most small ships are in the 170-180 dB re 1 μ Pa range, excluding infrasonic components (Greene and Moore, 1995). The actual noise produced could vary greatly due to vessel size, engine size, engine type, hull structure, number and placement of propellers, and vessel speed.

Broadband underwater sounds from the supply ship Robert Lemeur in the Beaufort Sea were 130 dB at a distance of 0.56 km (Greene, 1987), and were 11 dB higher when bow thrusters were operating than when they were not (Greene, 1985, 1987). The Robert Lemeur has nozzles around the thruster propellers. Broadband sound levels from ships lacking nozzles or cowled propellers may be ≥ 10 dB higher than those from ships with the nozzles (Greene, 1987). Typical responses of marine mammals to small vessel noise are behavioral reactions, or no visible reaction, depending upon circumstances. Small vessel types used to hunt or harass marine mammals elicit greater responses than vessel types that don't engage in such activities (Richardson, 1995). Decibel levels produced by small vessels are usually insufficient to produce a TTS or PTS.

Large Vessels

Large vessels (≥ 85 m) are characterized by powerful engines with large, slow-turning propellers that produce low frequency sounds with high sound levels (Richardson, 1995). Radiated noise is mostly a function of vessel size, engine size, speed, load, and mode of operation. Usually large vessels are louder than smaller vessels with most of the noise levels produced at the lowest generated frequencies. In order for higher decibel levels to affect a marine mammal, the produced noise levels must occur within the audible frequency range for that particular species. Noises at 2 Hz and below lie below the audible range for most marine mammals and should have negligible levels of effect on marine mammals near the noise; however, other noises above 5 Hz would probably be heard by some marine mammals. Such noise could produce avoidance reactions. Such vessels are not expected to be part of the Proposed Action.

Vessel Presence

Reactions to vessel noise may occur long distances from any actual vessel, while reactions not induced by sound could occur much closer to vessels. A number of variables determine whether a marine mammal is likely to be disturbed by vessels, including the ambient noise level, wind direction, the number of vessels, distance between a vessel and a marine mammal, vessel speed and direction, vessel noise, vessel type or size, habituation, threat association, and activity of the marine mammal.

Table 4.3.4-6. Extent of noise above interim behavioral thresholds for transportation activities.

Activity	Radius of Noise above Behavioral Threshold (Ice Covered)	Minimum Radius of Noise above Behavioral Threshold (Open Water)	Median Radius of Noise above Behavioral Threshold (Open Water)	Maximum Radius of Noise above Behavioral Threshold (Open Water)	Radius of Noise above Behavioral Threshold (Airborne)
Vessel Traffic, barge (2 hrs/day)	n/a	1500 m	1850 m	2200 m	<15 m
Vessel Traffic, Tugboat (2 hrs/day)	n/a	760 m	880 m	1020 m	<15 m
Vessel Traffic, Crew Transport (4 hrs/day)	n/a	200 m	260 m	320 m	<15 m
Hovercraft Traffic	n/a	~10 m	70 m	95 m	15 m
Helicopter Traffic	n/a	n/a	n/a	n/a	67 m

Small Vessels

Schevill (1968) found that motorboats that had been modified to run more quietly (partially silenced) had greater success than un-silenced boats at moving among cetaceans without producing reactions. Richardson (1995) cited studies from Salter (1979) and Fay (1981) in which walrus showed no detectable response to motorboats unless approached too closely, despite the noise from operating outboard engines. Walrus respond to the odor of the exhaust and other smells from the vessels and may be approached more closely from downwind, but will flush rapidly when approached upwind.

Polar bear reactions to vessels are variable, depending upon the bear and the situation. They may react to small vessels by fleeing or approaching. Females with cubs are more likely to be wary and avoid vessels. All polar bears are less likely to flee while engaged in eating or resting at a carcass. Most vessels would be in open water and are unlikely to encounter polar bears. Only vessels operating near barrier islands, in sea ice, or near the ice edge are likely to have interactions with polar bears, which generally show tolerance to vessels.

The responses of mysticetes are mixed. They show a great deal of tolerance to vessels that are stationary or distant, and strong avoidance of moving vessels. The responses of odontocete whales differed from that of mysticetes in that many toothed whales do not avoid vessels if they do not recognize vessels as threats, and often approach vessels. However, some species, such as belugas, may display strong avoidance reactions to vessels, particularly if they belong to a hunted population (Richardson, 1995).

Vessel Strikes. Small vessels would be used for support operations and equipment/personnel transport. These vessels are <85 m (279 ft) long and can quickly respond to marine mammal presence in relatively short distances, avoiding collisions. Some marine mammals may also be injured by propeller strikes, and such injuries most often occur in close quarters and during quick turns and backing.

Large Vessels

Richardson (1995) observed that pinnipeds in Alaska easily habituate to the presence of large vessels unless approached to within approximately 200 m (656 ft). Resting walrus are acutely sensitive to

smells and may be closely approached by large vessels if they are downwind, but will flush if the vessel is upwind at a much greater distance.

Polar bears and large mysticete whales tolerate large vessels unless those vessels directly approach them (Richardson, 1995), in which case they often attempt to escape. Mysticete whales have long lifespans; bowheads in the western Arctic were commercially hunted until the 1960s and may associate large vessels with whaling. In comparison, odontocetes such as killer whales regularly approach vessels of all size classes, and some dolphin and porpoise species seem to enjoy “riding” in the bow waves of passing vessels. Beluga reactions to vessels are mixed and may vary with location. Some belugas in the Gulf of St. Lawrence seasonally habituate to boats, while others in Arctic Canada show strong escape reactions from vessels and icebreaking (Richardson, 1995). Polacheck and Thorpe (1990) noted harbor porpoises tended to swim away from approaching vessels, while Evans et al. (1994) found varying harbor porpoises responses according to vessel size and behavior.

Vessel Strikes. Large vessels employed for oil and gas exploration activities range from 85 m (279 ft) to ≥ 110 m (≥ 361 ft) in length. Vessel speeds range up to 16.5 knots when transiting. Laist et al. (2001) noted that 89% of all whale collisions in which a vessel killed or severely injured a whale occurred with vessels moving at 14 knots or greater. No collisions occurred at speeds of less than 10 knots. Collision records first appear late in the 1800s when the fastest vessels began attaining speeds of 14 knots, and then increased sharply in the 1950s-1970s when the average speed of most merchant ships began to exceed about 15 knots. Large vessels in the Arctic region typically operate at less than 10 knots between locations.

Large vessels cannot perform abrupt turns and cannot slow down quickly over short distances in reaction to marine mammal presence. Effects on large whales are dependent upon the interaction of visual presence; timing, duration, and frequency of trips to work locations; routing, and seasonal and concurrent numbers of large vessels operating in a region; and spatial/temporal overlap with the seasonal distribution, including critical life function habitats (breeding, calving, nursing, feeding, migrating, resting areas etc.) of large whales.

Transportation: Aircraft

Aircraft Noise.

According to Greene (1995), when the angle between the aircraft and the water surface exceeds 13 degrees from a noise receiver, much of the incident sound is reflected and does not penetrate into the water. Strong underwater sounds remain detectable so long as the aircraft is within a 26-degree cone from the noise receiver. This means that an aircraft usually can be heard in the air well before and after the brief period that it passes overhead and is heard underwater.

Under the Proposed Action, aircraft would transit between the proposed LDPI and Deadhorse and/or the Endicott SDI. Aircraft activity could have acoustic and non-acoustic effects on marine mammals. Low passes by aircraft over a cetacean, including a bowhead, gray, or beluga whale, can result in short-term behavioral responses such as diving, direction changes, or swimming away (Luksenburg and Parsons, 2009; Richardson et al., 1995), or could incite panic among pinnipeds (Rugh, Shelden, and Withrow, 1997).

Helicopters

Most helicopter use in support of OCS activities is for ferrying personnel and equipment to OCS operations, and involves turbine helicopters. For noise mitigation purposes, helicopter flights are kept at a 1,500 foot altitude Above Ground Level (AGL) or Above Sea Level (ASL) unless safety requirements necessitate lower altitudes (NMFS, 2013b). According to Greene and Moore (1995: pp.102-110), helicopters are capable of producing tones mostly in the 68 to 102 Hz range, at noise levels up to 151 dB re 1 μ Pa-m at the source. Additionally, they radiate more sound forward than

backwards, which means noise levels would be audible at greater distances ahead of the aircraft than to its rear. Helicopter sounds measured underwater at depths of 3 and 18 m (9.8 and 59 ft) showed that sound consisted mainly of main-rotor tones ahead of the aircraft and tail-rotor sounds behind the aircraft; more sound pressure was received at 3 m (9.8 ft) than at 18 m (59 ft); and peak sound levels received underwater diminished with increasing aircraft altitude. Sound levels received underwater at 3 m (9.8 ft) from a Bell 212 flying overhead at 150 m (492 ft) ranged from 117-120 dB re 1 μ Pa in the 10- 500-Hz band. Underwater sound levels at 18 m (59 ft) from a Bell 212 flying overhead at 150 m (492 ft) ranged from 112-116 dB re 1 μ Pa in the 10-500-Hz band.

Helicopter noise is generally audible for tens of seconds as a helicopter is approaching or departing an area. Individual marine mammal responses appear to vary depending on flight altitude and received sound levels. Humpback whales in large groups showed little or no response, but some adult-only groups exhibited avoidance (Herman, 1980), while species such as ringed and spotted seals and walrus have exhibited noticeable flight reactions to helicopters (Born et al., 1999; Richardson, 1995; Burns and Harbo, 1972; Faye, 1982).

Fixed-Wing Aircraft

Fixed wing operations typically assess marine mammal habitat use, distribution, and movement; they also monitor behavior before, during, and after seismic surveys and drilling operations occur. Monitoring surveys are typically conducted with aircraft flying above 1,500 ft AGL unless safety becomes an issue. Greene and Moore (1995:102-105) explained fixed wing aircraft typically used in offshore activities were capable of producing tones mostly in the 68 to 102 Hz range and at noise levels up to 162 dB re 1 μ Pa-m at the source. Though the noise levels of aircraft are insufficient to create physiological effects among marine mammals, it could produce behavioral responses that include avoidance, increased dive time, etc.

Aircraft Presence

Aircraft traffic in support of OCS activities includes helicopter flights for personnel transport and fixed-wing aircraft engaged in monitoring activities.

Flight Paths

Aircraft flying below 500 ft (152 m) have a much greater likelihood of startling or affecting marine mammals. Similarly, aircraft flying over groups of marine mammals are much more likely to elicit startle responses than those that fly over individuals. Hauled out spotted seals have been known to respond to low-flying approaching helicopters from distances up to 0.25 mi (400 m) or greater, and walrus have been known to startle and flee from aircraft approaching below 1,000 ft (305 m) (Richardson, 1995). Pinnipeds on ice or on land are likely to show greater responses to aircraft traffic than those in the water. Most cetacean species have exhibited responses to low-flying aircraft by diving deeper, or for longer times. With species such as bowhead whales, much of the responsiveness of individuals to passing aircraft is a function of aircraft and animal activities, noise production, and time of year.

Flight Frequency

Pinnipeds could be expected to partially habituate to frequent aircraft flights, although at some level of flight frequency seals could begin to respond more frequently or strongly to the disturbance (Richardson, 1995). It is likely cetaceans would exhibit behavioral responses similar to those of pinnipeds. Consequently, marine mammals should habituate to increased flight frequency unless the frequency of flights passes some threshold resulting in higher levels of responsiveness to aircraft flights. Flights during winter and early spring should mostly affect polar bears and ringed and bearded seals. Those flights occurring in the late spring and open-water season have the potential to impact all species of marine mammals found in and around the Proposed Action Area.

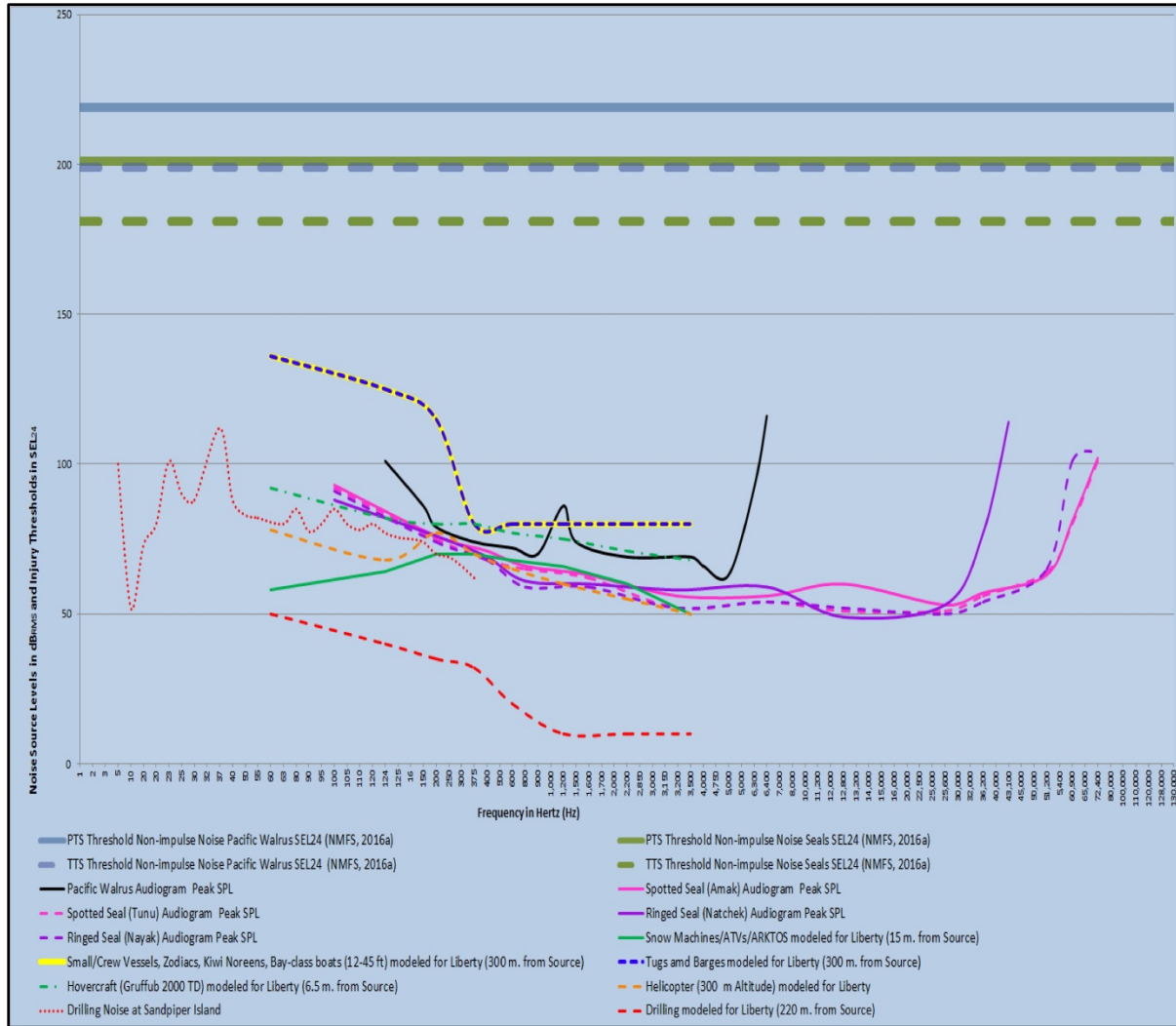

Figure 4.3.4-8. Vessel, Snow Mobile, Hovercraft, Helicopter, and Drilling Noises vs. ringed, spotted seal, and Pacific walrus audiograms, and NMFS Noise Injury (Level A Harassment) Thresholds (NMFS, 2016a). Sources: Sills Southall and Reichmuth, 2014, 2015; Kastelein et al., 2002; SLR, 2017; NMFS, 2016a.

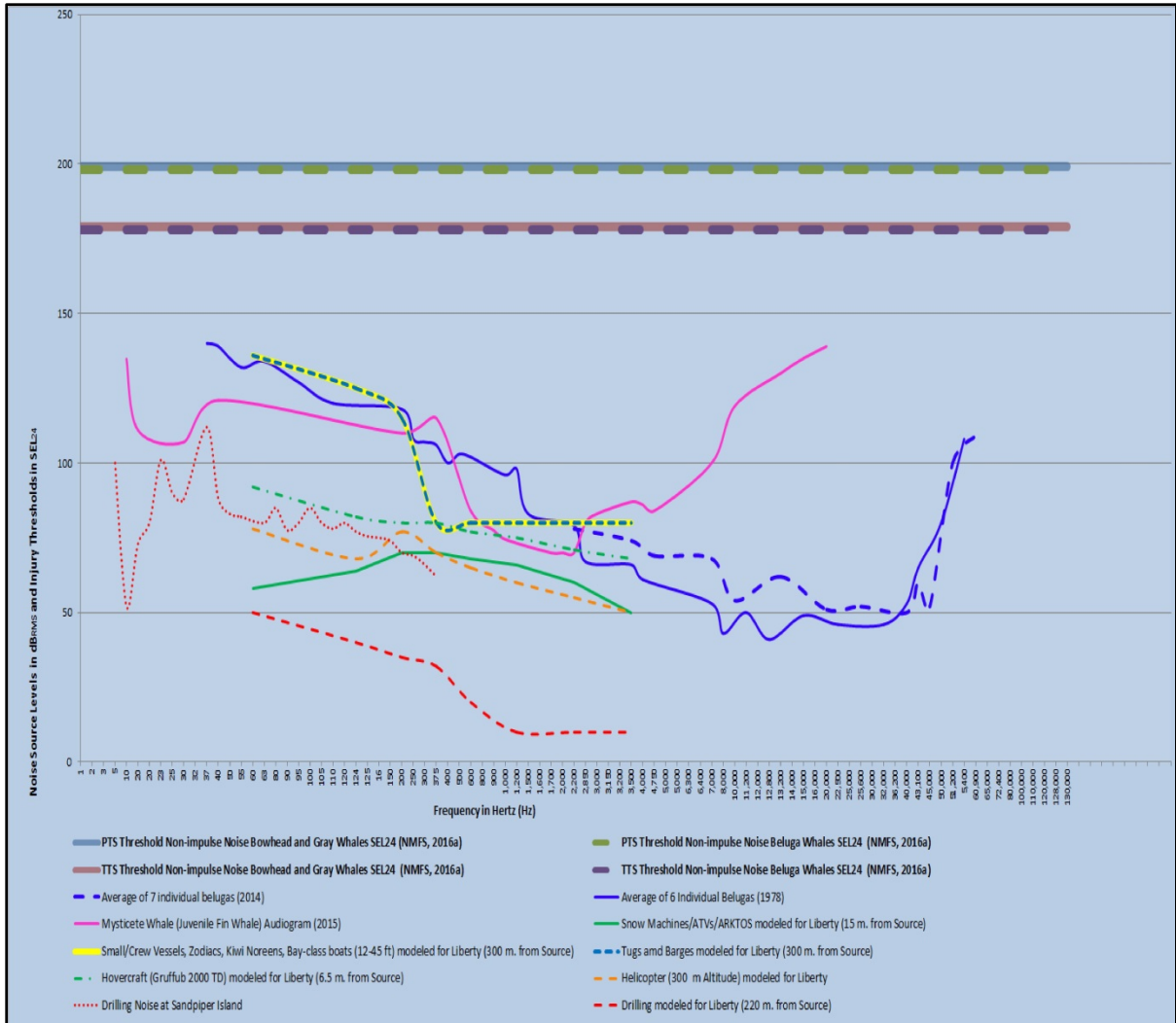

Figure 4.3.4-9. Helicopter, Drilling, Hovercraft, Snow Machine, and Vessel Noises vs. Beluga Whale Audiograms and NMFS Injury Thresholds from noise (Level A Harassment). *Audiograms of beluga whales compared to the sounds emitted by proposed helicopter, drilling, and vessel noises; and the NMFS harassment criteria thresholds (Miles et al. 1986; Greene and Moore, 1995; Awbrey, Thomas and Kastelein, 1988; Castellote et al., 2014; Nedwell et al., 2004 ; White et al., 1978 ; Johnson, McManus, and Skaar, 1989).*

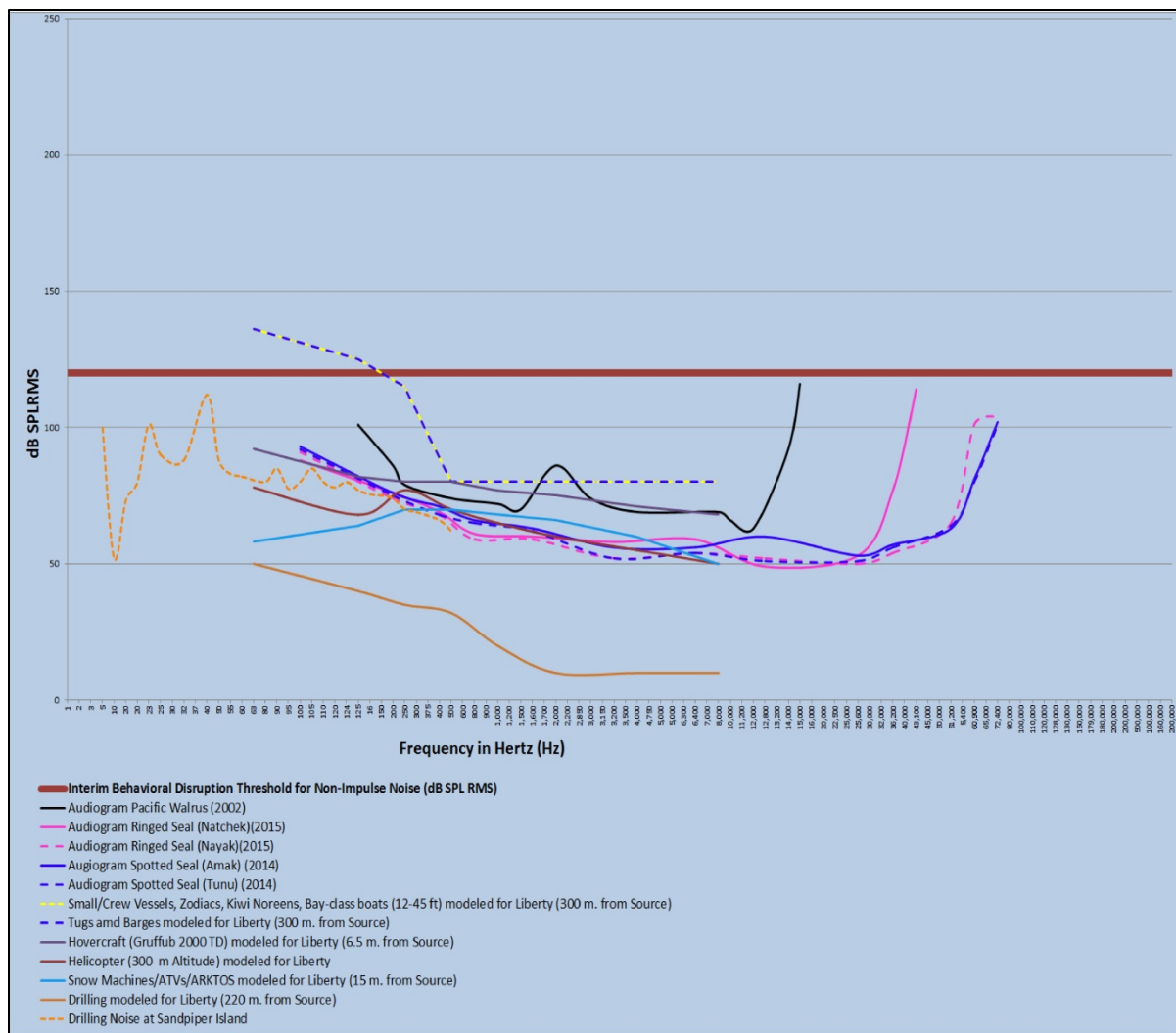

Figure 4.3.4-10. Comparing vessel, helicopter, hovercraft, snow machine, and drilling noises to the NMFS interim behavioral thresholds (Level B Harassment). Figure illustrates the relationship of vessel, helicopter, hovercraft, snow machine, and drilling noises to the NMFS interim behavioral thresholds (Level B Harassment) with respect to sound frequencies and noise intensity on the dB_{RMS} scale.

Figures 4.3.4-7 and 4.3.4-8 show noise production from drilling, helicopter operations, and vessel noises. Large vessels are unlikely to be used in the Proposed Action because the 19 ft depths at the LDPI would prohibit many large ships from entering the area near the LDPI. Most vessel traffic would consist of small size class vessels taking people and supplies to and from the LDPI. Noise production estimates were graphed using the loudest potential noise levels, helicopters and small vessels, while the noise production of large vessels and drilling were made using actual data, or close approximations thereof. Generally, Figures 4.3.4-6, 4.3.4-7, 4.3.4-8, 4.3.4-9, and 4.3.4-10 overestimate the actual noise production by a large margin. As can be seen in Figures 4.3.4-7 and 4.3.4-8, drilling noise from the Sandpiper Island, near the LDPI, mostly peaked between 20 and 530 Hz, and noise from barge sized vessels peaked at around 5 Hz before rapidly dropping off.

Wastewater Discharges

During the drilling and operation/production phases of the Proposed Action, no discharge of wastes, or camp wastewater are planned. Such materials would be injected into a waste disposal well, unless that well is temporarily non-operational. Occasionally unforeseen events could occur that might

necessitate discharging wastewater; however, such discharges would be in accordance with NPDES permits or collected and disposed of at an appropriately permitted onshore facility. Consequently, wastewater discharges under normal operation conditions should not affect marine mammals since the wastes would be sent into the injection well, removed to an onshore facility, or in the rare instance released into the environment in a manner compliant with NPDES permits. Discharges from vessels would be in compliance with USCG requirements and should not affect any marine mammals.

Sedimentation from proposed LDPI Construction, Pipeline Trenching, and discharge of drilling muds and cuttings

The winter placement of gravel fill for the LDPI and pipeline installation would increase suspended sediment concentrations in the marine waters in the immediate vicinity of the construction sites and create a turbidity plume extending into nearby areas. During the open-water construction season, as compared to winter construction, decreased Total Suspended Solids (TSS) concentrations are expected, attributable to the release of fine-grained material during gravel grading operations and winnowing by waves and currents. The deposition of fill materials and excavation of the pipeline route would occur during winter when ringed seals and the occasional polar bear would be the only marine mammal species found in the vicinity of the Liberty Project. Turbidity generally doesn't directly affect marine mammals except through effects to their prey species.

Any cuttings or drilling muds would be stored onsite until disposed of in waste disposal wells or delivered to an appropriate onshore facility for disposal. For these reasons sedimentation from drilling should not affect the marine environment. Sedimentation from the construction of the LDPI and the pipelines would result in a short-term release of sediments into the water which would be dispersed across a broad area. The effects to marine mammals from such sedimentation events would generally be negligible considering the potentially small amount of prey species habitat that would become compromised, and the tendency of benthic and pelagic species to reoccupy areas after sedimentation events.

Accidental Oil Spills

Accidental events could include small (<1,000 bbl) and large (\geq 1,000 bbl) spills stemming from the LDPI or the pipeline. Accidental discharge of oil can occur during development, production or decommissioning. Small and large oil spills are considered accidental events, and the Clean Water Act and Oil Pollution Act include regulatory and liability provisions designed to reduce damage to natural resources from oil spills. Oil spills are further discussed in Section 4.1.1-1.

Small oil spills

Small refined oil spills (<1,000 bbl) could occur during development, in conjunction with construction activities, and drilling. Section 4.1.1 and Tables 4.1.1-1 and 4.1.1-2 describe the assumptions concerning small oil spills. Small refined spills could occur at any time, and Tables A.1-7 and A.1-8 show that small refined oil spills would evaporate and disperse within 3 days or less during summer. Because small refined oil spills dissipate rapidly, and would be rapidly cleaned up, they should have negligible effects on marine mammals.

Large Oil Spills

Large oil spills (\geq 1,000 bbl) are unauthorized events. Spill prevention and response plans, including in-place equipment, personnel and infrastructure, are required for all operations (30 CFR 254). Marine mammal species could be affected depending on the location, timing, duration, sea and climatic conditions, and response to spill events. Oil spill events occurring during the late summer could overwinter and result in contact with polynyas the following spring though weathering could decrease the volatility and toxicity of the spilled oil if the oil became frozen into sea ice.

Potential physiological effects that could lead to reduced marine mammal fitness include:

- Irritation, inflammation, or necrosis of skin; chemical burns of skin, eyes, mucous membranes; inhalation of toxic fumes with potential short- and long-term respiratory effects (e.g., inflammation, pulmonary emphysema, infection), potentially leading to mortality.
- Partial or extensive coating of pelts with oil for polar bears would reduce insulation and could result in hypothermia and ingestion of oil during grooming; either could result in mortalities.
- Ingestion of oil (and dispersants) directly or via contaminated prey, leading to inflammation, ulcers, bleeding, damage to liver, kidney, and brain tissues, potentially leading to mortality. Disturbance from beach cleanup crews, vessels and aircraft during spill response and cleanup.
- Oil coating baleen in mysticetes whales which could adversely affect baleen functionality in sieving food from seawater.

Complications of the above may lead to reduced fitness, injury and mortalities (NRC 2003; Geraci 1990). Determining mortality rates for marine mammals, particularly for cetaceans, during an oil spill can be difficult. For example, not all animals found dead necessarily died from exposure to oil. Gray whales found after the 1969 Santa Barbara spill were initially thought to have died from the spill, but that conclusion was reversed after examination of the whales found no linkage to the spill. Similarly, the dead, stranded gray whales observed after the *Exxon Valdez* Oil Spill could not be linked to the spill, and the increased observations of strandings were attributed, at least in part, to the increased search effort associated with the spill (NRC 2003). Also during the *Exxon Valdez* Oil Spill, pods of killer whales were observed swimming through the spilled oil (Matkin et al. 2008). Many carcasses sink after death and cannot be recovered, making effects determinations for such events problematic. In addition to short term mortalities, sub-lethal impacts may affect individual fitness, reproduction, prey availability and behavior (Wursig 1990).

Materials transportation carries the risk of accidental or illegal releases of toxic substances, which, due to their immediate and potentially long-term effects on individual animals, populations, food webs, and the environment, could impact marine mammals (Arctic Council, 2009). There is a lack of accident response resources in the Arctic as well as a lack of effective techniques for containing or cleaning up spilled oil under ice or in broken ice. There are also challenges of associated with conducting a rapid, effective spill response in a region where weather is often severe, daylight may be limited, and may happen in remote locations (AMAP, 2007).

Oil-Spill Response and Cleanup

Cleanup activities following an oil spill could involve multiple marine vessels operating in the spill area for extended periods of time. As explained in the discussion of impacts associated with vessel traffic, cetaceans and pinnipeds may react to the approach of vessels with avoidance behavior, and the potential for vessel collisions with marine mammals could increase. Vessels would typically be responding to surface oil, whales, walrus and ice seals may be displaced from oiled areas, reducing the potential for contact. In oiled feeding areas, whales, walrus and ice seals would have a reduced potential for fouling baleen or ingesting oiled prey as long as the vessels were present. If a spill occurred in an area near the ice edge or where pack ice was present, polar bears could also be impacted. Also, polar bears could become oiled along shorelines, when swimming, or when hunting around the ice edges.

After a large oil spill, helicopter and fixed-wing aircraft overflights would typically be used to track the spill and to monitor distributions of marine wildlife. This monitoring helps guide response, and efforts are made to prevent oil from contacting important animal concentrations or concentration areas. As explained in the discussion of impacts associated with aircraft traffic, the impacts to marine mammals from aircraft encounters are transient and animals will typically resume normal activities within minutes.

Oil-spill-cleanup activities could increase disturbance effects on whales, polar bears or pinnipeds, causing temporary disruption and, possibly, displacement. In the event of a large oil spill contacting and extensively oiling coastal or ice-covered habitats, the presence of response staff, equipment, and aircraft involved in the cleanup could (depending on the time of the spill and the cleanup) potentially displace whales, walrus, polar bears and ice seals. If extensive cleanup operations occur in the spring, it could cause increased stress and reduced pup/calf survival of ringed seals/walrus. Oil-spill-cleanup activity could exacerbate and increase disturbance effects on prey species, cause localized displacement of prey species, and alter or reduce availability. The displacement of marine mammals away from oil-contaminated areas by cleanup activities, however, could reduce the likelihood of direct contact with oil. Alaska Clean Seas (2016) and HAK have existing strategies for hazing polar bears away from contaminated areas, with prior authorizations from the USFWS to intentionally harass polar bears as necessary.

On-Ice Spill/Under-ice Rupture

Stefansson Sound and the Beaufort Sea are covered with several feet (about 2 m (6 ft) of shorefast ice during winter and early spring. An on-ice spill could occur; however, the proposed Liberty site occurs in an area of continuous shore-fast ice which would prevent spilled oil or gas from entering the Beaufort Sea from a spill at the proposed LDPI. Cleanup actions would include collecting all oil or gas from the spill, and processing the spilled products or contaminated materials at appropriate facilities.

Small pipeline ruptures under shorefast ice would be similar in some respects to naturally occurring oil and gas seeps found throughout the world's oceans, and would most likely have negligible levels of effect on marine mammals.

Large oil spills occurring under sea ice could force a shutdown of that pipeline until the situation is remedied. Depending on the location of the spill, materials could be flushed out into Stefansson Sound, or could rise to the bottom of the shorefast ice. During spring, some of this oil would likely be transported through the ice to the top of the affected shorefast ice area via capillaries, or reach the water's surface when broken ice develops. Some of that oil could be cleaned up using conventional methods until shorefast ice degrades and no longer safely permits cleanup activities. If left untreated, the oil remaining in the ice would subsequently break up with the ice and gradually disperse in chunks of ice into the Beaufort Sea. Occurrence of such oiled sea ice would most likely be dispersed over a broad area and the ensuing effects would be similar to those of small spills.

Spills occurring under ice or in the brief period when broken ice is present, would be cleaned and removed using techniques developed by Alaska Clean Seas (2016), and HAK.

Construction

During construction of the Northstar Project in 2000, the underwater noise field was dominated by noises from Northstar Island below 500 Hz, and rising about 45 dB above the ambient noise levels; however at about 1 km from the project, the dominance of man-made noise only occurred at frequencies below 100 Hz, and at 2 km only energy in the 23 Hz tonal and those noises below 7 Hz were detected above the ambient noise levels (Shepard et al., 2001).

Ice Road Construction and Heavy Equipment Operations

During the winter and spring seasons, the nearshore waters of Foggy Island Bay are covered in natural ice sheets up to 6 feet thick. Winter ice roads would be constructed using Arctic Best Management Practices (BMP), to allow trucks to move construction materials to the Liberty Site, and to access eastern developments. Ringed seals and polar bears are the only species that would occur in the vicinity of ice roads since the other marine mammal that overwinters in the Beaufort Sea, the bearded seal, use lead systems and polynyas during winter. The noise from ice road use could disturb

some ringed seals in their dens, which potentially could lead to adverse behavioral reactions between adult and neonate ringed seals.

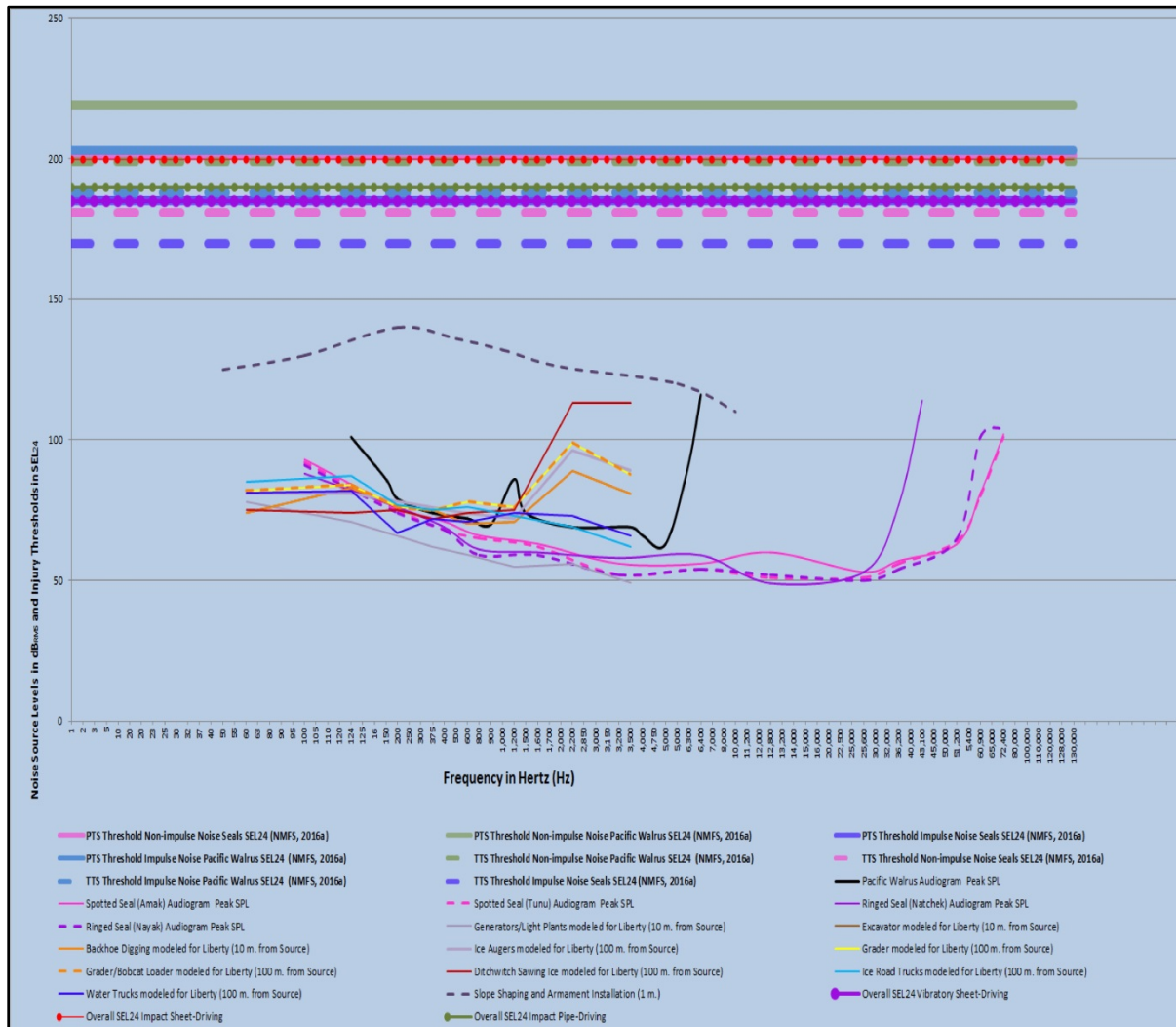

Figure 4.3.4-11. Ice road and LDPI Construction Noise and Pinniped Audiograms, Audiograms compared to the sounds emitted by proposed construction equipment on ice road and proposed LDPI construction. Includes NMFS and USFWS harassment criteria thresholds. Sources: Sills et al. 2014 ; Sills et al. 2015 ; Kastelein et al. 2002 ; Greene et al. 2008 ; USFWS.

During construction of the ice roads leading to the Northstar project, several bulldozers and rollagons were in use simultaneously at any given time. The noise levels from these various types of heavy equipment were later analyzed, and Greene et al. (2008) determined ice road construction was one of quieter activities occurring during the construction of the Northstar Project (Table 4.2.5-1). The conclusion of Greene et al. (2008) found ice road construction was collectively (bulldozers, trucks, Ditch Witches, augers, pumps, etc.) the least noisy activity that occurred with the Northstar Project during winter.

Table 4.3.4-7. Northstar Project Ice road and Island Construction Heavy Equipment Noise.

Sound Source	Broadband SPL at 100 m (dB re 1 µPa)	Frequency Bandwidth of produced noise ≥100 (dB re 1 µPa)
Bulldozer	114.2	31.5 Hz–125 Hz
Augering	103.3	None
Pumping	108.1	500 Hz–1 kHz

Sound Source	Broadband SPL at 100 m (dB re 1 µPa)	Frequency Bandwidth of produced noise ≥100 (dB re 1 µPa)
Ditch Witch	122	<5 Hz - 3.15 kHz
Trucks	123.2	<5 Hz–500 Hz
Backhoe	124.8	<5 Hz–1.2 kHz
Vibrahammer, sheet-driving	142.9	23 Hz–25 Hz
Sheet Pile-driving	148	5 Hz–55 Hz
*Background Noise	78–110	20 Hz–5 kHz

Note: * Highly variable due to changing environmental variables.
 Sources: Greene et al., 2008; ; Blackwell, Lawson, and Williams 2004.

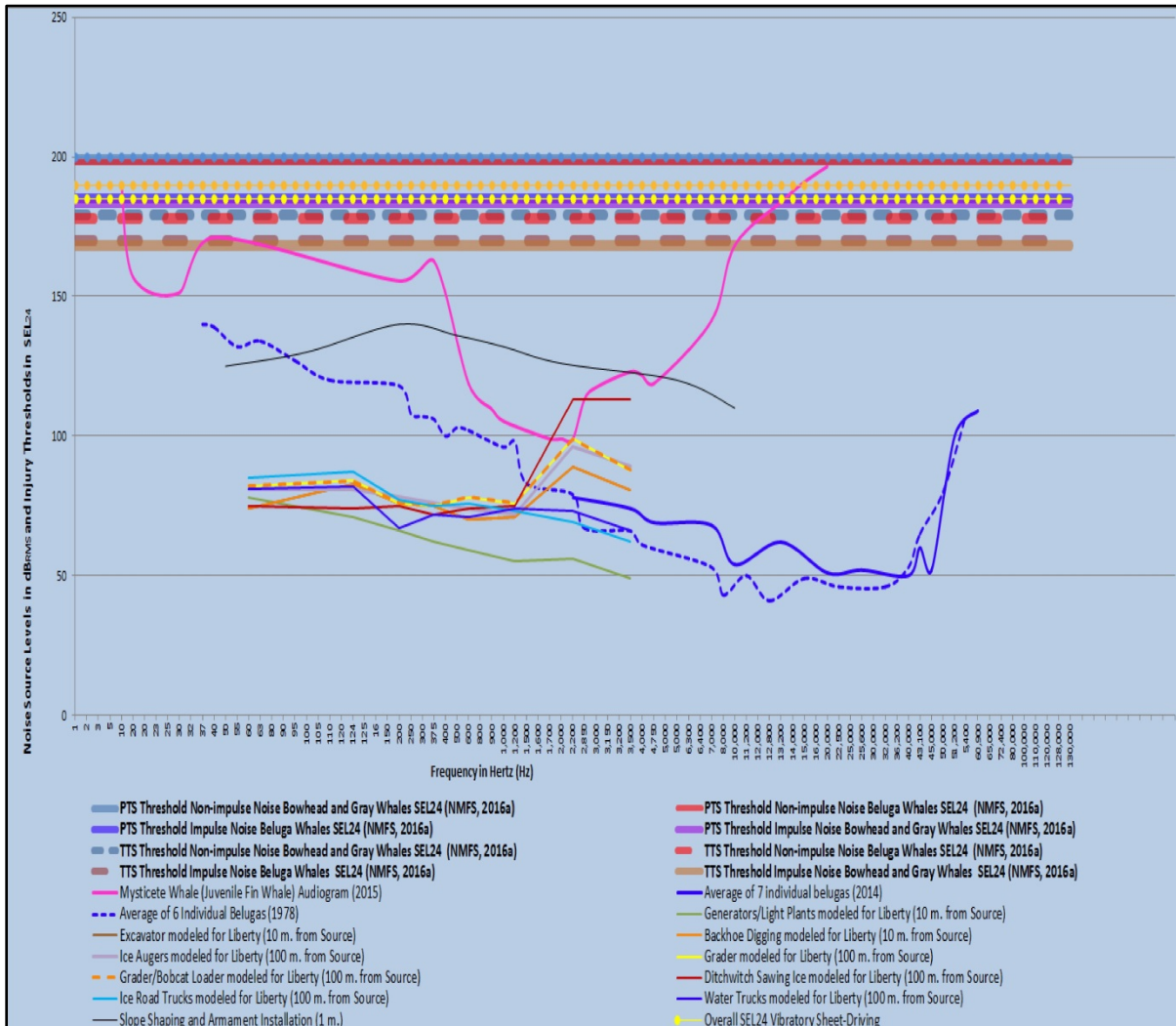

Figure 4.3.4-12. Ice road and LDPI Construction Noise and Beluga Whale Audiograms Audiograms of beluga whales compared to the sounds emitted by proposed construction equipment on ice road and proposed LDPI construction. Includes NMFS harassment criteria thresholds. Sources: Awbrey, Thomas and Kastelein, 1988; Castellote et al, 2014; Greene et al. 2008; Johnson, McManus, and Skaar, 1989; Nedwell et al. 2004 ; White, et al. 1978.

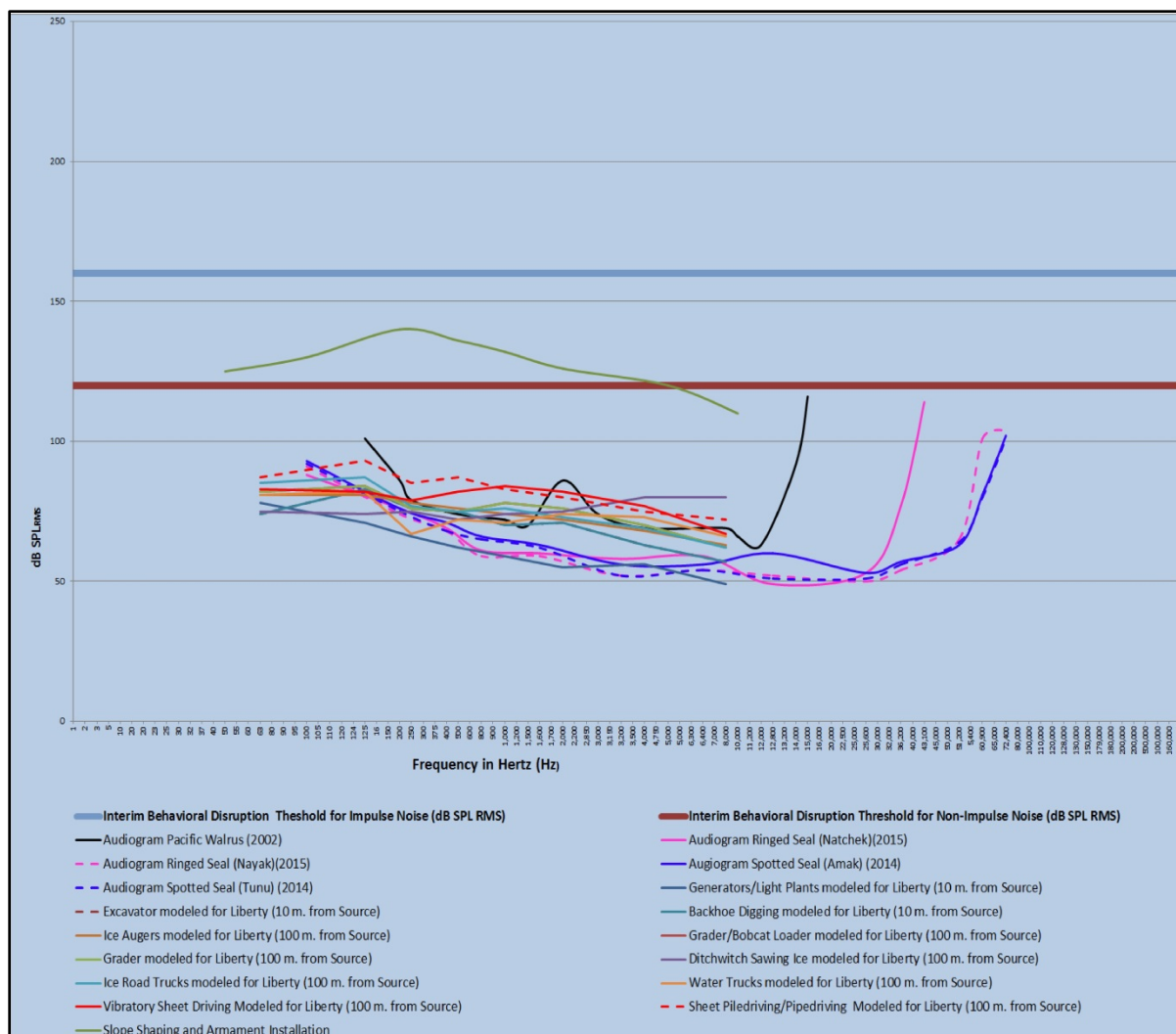

Figure 4.3.4-13. Ice road and LDPI Construction Noise Behavioral Response Thresholds (Level B Harassment) for impulse and continuous noise. Sources: SLR, 2017; NMFS-2016a. Illustrates the relationship of noises from construction activities and the NMFS interim behavioral thresholds (Level B Harassment) with respect to sound frequencies and noise intensity on the dB_{RMS} scale.

Vehicles

The use of vehicles would have little potential to affect marine mammals in the Beaufort Sea through much of the year. Vehicles would typically be used during winter months when there is a thick layer of shorefast ice that would permit the development of ice roads to and from the project site. At times when the ice is unstable, which includes spring, summer, and fall, the use of vehicles would end and there would be no potential for adverse effects on marine mammals. Consequently, marine mammals that occur in the vicinity of the Liberty Project during winter are the only marine mammal species that could be affected by vehicle use. Greene et al. (2008) measured noises from gravel trucks at around 123.2 dB re 1 μ Pa using hydrophones (Table 4.3.4-6); however SLR (2017) modeled the noise from vehicle use and found they were much less for the Proposed Action (Figure 4.3.4-9).

Proposed LDPI Construction

The Liberty Drilling and Production Island (LDPI) is an artificial island proposed to be constructed in 19 feet of water in Foggy Island Bay in the Beaufort Sea. The proposed LDPI includes placement of approximately 926,559 cubic yards (cy) of gravel, secured with sheet piling, and armored with linked

concrete mats. The surface of the proposed LDPI is designed to be 15 feet above sea level with a working surface of approximately 9.3 acres and a design seabed footprint of approximately 24 acres.

Noises (strongest 1/3 octaves) produced during construction of the Northstar project in 2000 were mostly under 300 Hz (Greene et al. 2008)

Vibratory and Impact Sheet Pile, and Pipe Driving

Vibrahammers were initially used to drive sheet pilings during the construction of the Northstar facility in 2000 (Shepard et al., 2001). A Vibrahammer is a heavy device attached to a standing sheet pile which vibrates vertically, driving the sheet into the ground. These vibrations are believed to mostly travel through soft substrate into the lower areas in the water column (Shepard et al., 2001), with greater transmission loss in shallow water. Noise transmission frequencies occurred at 24-25 Hz at the Northstar Project, and <50 Hz at two islands in Prudhoe Bay (Greene, Blackwell, and McLennan 2008; Shepard et al., 2001). The noise levels from vibratory sheet piling extended up to around 143 dB re 1 μ Pa at 100 m from the noise source (Greene, Blackwell, and McLennan 2008).

After sheet pilings were planted to a certain depth using vibration, impact pile driving was used to further set the piles deeper into substrate. The noises produced by the impact pile driving mostly occurred at frequencies below 55 Hz and at noise levels up to 148 dB re 1 μ Pa at 100 m from the island (Greene, Blackwell, and McLennan 2008, Blackwell, Lawson, and Williams 2004).

At the Northstar Project, the collective broadband sounds from pile driving diminished into the range of median background noise levels at distances of 1-5 km from the noise source. Of those noises, about 35% attenuated out within 1 km from the source, while 55% of the noise dropped to within natural noise levels within 2 km of Northstar, and 90% of the man made noises attenuated within 4 km of the island (Greene, Blackwell, and McLennan, 2008; Blackwell, Lawson, and Williams, 2004).

SLR (2017) modeled the noise production from vibratory sheet piling, impact pile-driving, and pipe driving (Figures 4.3.4-11 thru 4.3.4-13). Only the noise from vibratory sheet piling and impact pile-driving/pipe-driving had the potential to create injury (Level A Harassment) among any marine mammals and those noise levels never exceeded any PTS thresholds.

Table 4.3.4-8. Theoretical distances from impact pipe-driving and pile driving at the Proposed LDPI to onset of Permanent Threshold Shifts among marine mammal.

Marine Mammal Functional Hearing Group	PTS Threshold for Impact Sheet Pile-Driving	PTS Threshold for Impact Pipe-Driving
Low Frequency Cetaceans – bowhead and gray whales	770 – 1,220 m	870 m
Mid Frequency Cetaceans – beluga whales	25 – 37 m	27 m
Phocid Seals – bearded, ringed, and spotted seals	210 – 330 m	240 m

Source: SLR (2014).

Other Construction Noises (dredging, pipeline installation, etc.).

Richardson (1995) noted that dredges, which can be used to create artificial islands, to deepen channels, and for general offshore construction activities, can be major sources of underwater noise in some nearshore regions. Greene and Moore (1995) also found that dredges can be strong sources of continuous noise in nearshore regions, and that the noise they produce is strongest at low frequencies.

This continuous noise may be audible for distances ≥ 25 km in nearshore areas. In past surveys, the interactions of beluga whales, bowhead whales, and dredge noise was observed; some slight aversion was observed in some bowhead whale responses, while belugas showed greater reactions to large ships. Moreover, other bowhead whales did not modify their behavior in areas where actual dredging occurred, which indicates that some level of habituation to dredge noise may develop among cetaceans. Bryant et al. (1984, as cited in Richardson, 1995) found wintering gray whales avoided a lagoon in Baja California for several years when dredging activities were occurring. Decibel levels up to 30 dB above ambient noise levels were detected by Richardson, Würsig, and Greene (1990) during a related study in the Beaufort Sea, and henceforth the assumption that dredging produces low-frequency noise and decibel levels approximately 30 dB above the ambient noise levels in the Proposed Action Area. Dredging noises are strongest at lower frequencies and are not typically detectable within 20-25 km of the source due to the rapid attenuation of low frequencies in water.

Richardson (1995) summarized information relating to island construction noises, concluding that marine mammals generally do not avoid equipment operating on small islands, and under some conditions certain species may even become curious and investigate such activities.

SLR (2017) analyzed the noises produced by island construction activities, and found those noises occurred below the behavioral effects thresholds (Level B Harassment) for all marine mammal species.). Based on existing audiogram data, most construction noises occurred at or below the hearing thresholds of spotted and ringed seals, Pacific walruses (Figure 4.3.4-11), and beluga whales (Figure 4.3.4-13). For these reasons, construction noises, other than vibratory sheetpile driving, and impact pile-driving/pipe-driving are unlikely to have adverse effects on marine mammals.

Construction/Decommissioning Activity

Construction and decommissioning activities should have limited effects on marine mammals in the Proposed Action Area. The primary source of disturbance from construction activities would be the noise produced by pile driving, trenching, proposed LDPI construction, ice road construction, and laying in pipelines.

Proposed LDPI construction would produce a long-term seafloor footprint that would result in the loss of some benthic foraging habitat; however if left in place upon decommissioning, might provide additional solid substrate for colonization by Boulder Patch organisms. If the proposed LDPI were removed upon decommissioning, the area would eventually be re-colonized by benthic invertebrates and fishes. The period of time it would take for colonization of the proposed LDPI's base by kelp might extend into decades, while it is anticipated a benthic re-colonization event of the seabed where after the proposed LDPI's removal would mostly occur in a matter of 5-10 years. In the absence of boats, underwater sounds from Northstar Island during construction, drilling, and production reached background values 2–4 km (1.2–2.5 mi) away in quiet conditions (Blackwell and Greene, 2006).

Drilling

Underwater sound associated with drilling from natural barrier islands or an artificial island built mainly of gravel is generally weak and inaudible at ranges beyond a few kilometers (Richardson et al., 1995). Almost all energy in the sounds emitted by drilling activities is at low frequencies, predominantly below 250Hz, with another peak centered around 1,000 Hz (USDOC, NMFS, 2012a). Such frequency ranges are sometimes used by cetaceans, including beluga, bowhead and gray whales, pinnipeds, and polar bears (Tables 4.3.4-1, and 4.3.4-2; Figures 4.3.4-2, 4.3.4-7, and 4.3.4-8). Drilling noises from the Northstar Island were recorded by Blackwell et al. (2004) in 2001 and 2002. Those noises occurred in the 10 Hz–10 kHz broadband spectrum, mainly in the 700 Hz–1.4 kHz bandwidth and at maximum levels of 124 dB re 1 μ Pa at 1 km, and attenuated to background levels within 9.4 km from the source (Blackwell et al. 2004), possibly due to the shallow depths which hinder sound propagation. It has been suggested that drilling noise at the purposed proposed LDPI during periods

of normal ambient conditions would attenuate to below-audible ranges approximately 2 km from the source (Richardson et al., 1995) though it might be detectable up to 10 km from the source during unusually calm periods (Greene and Moore, 1995).

Closer to the Liberty site lies Tern Island Shoal, the remnants of a man-made drilling island, where drilling occurred in February 1997. Direct measurements of under ice noise disclosed acoustic transmission loss at ranges between 0.2 and 2+ km and frequencies below 150 Hz, transmission loss was about 35 log (Range) plus an additional linear absorption term (Greene 1997). Greene (1997) noted that the strongest components of drilling noise occurred at frequencies below 170 Hz; however even in close proximity of 200 m from the drillsite, the highest detectable drilling sound occurred at 400 Hz. This was a high rate of attenuation, as expected for waters only 6 to 7 meters deep, depths similar to those at the Liberty Project. Attenuation rates could not be measured at higher frequencies, but were expected to be high. Consequently, noise from drilling operations on Tern Island generally was undetectable beyond 2 km, and below the low ambient noise levels in that area (Greene 1997).

More recently SLR (2017) modeled noise for drilling at the Proposed LDPI (Figures 4.3.4-5 thru 4.3.4-7) and found the drilling noise should occur below the minimum detectable levels for beluga whales, seals, and Pacific walruses based on audiogram data. At no time did drilling noise approach or exceed any behavioral (Figure 4.3.4-7), or injury (Figure 4.3.4-5 and 4.3.4-6) thresholds (NMFS-2016a).

Habitat alterations are expected through the removal of LDPI armoring and gradual erosion of the LDPI base. The subsea pipeline would be flushed of all contaminants, ends cut and sealed, and abandoned in place

Drilling operations introduce the potential for a large spill to occur. Impacts of large spills to whales are presented in Oil Spills – Large.

Species Specific Effects

The species-specific effects analyses for marine mammals address the impacts of the Proposed Action on the biology and/or ecology of marine mammals only. Due to differing scales of effect, and metrics they are not interchangeable with effects analyses for other resources in this document.

4.3.4.1. Whales

The primary impact producing factors associated with the proposed action would be noise from pile-driving, vessels, and aircraft, as well as the presence of aircraft and vessels. These factors were discussed in depth earlier in this section, under the subheading Impact producing factors.

4.3.4.1.1. The Proposed Action

Beluga Whales

Ice Road Construction and Use

Ice road construction and use would have no effect on beluga whales because they are absent from the Proposed Action Area during winter and spring when ice roads would be constructed and used.

Mine Site Development

Mine site development would have no effect on beluga whales because they are absent from the Proposed Action Area during winter and because mine activities would occur onshore.

Proposed LDPI Construction

Most proposed LDPI construction would not impact belugas because it would occur during winter and spring when beluga whales are absent from the Proposed Action Area (Section 3.2.4.1).

Installation of the proposed LDPI's slope protection would occur between May and August during the first summer of the Proposed Action and has the potential to impact belugas should they be in the vicinity of the proposed activities. These factors are discussed in depth in Section 4.3.4, proposed LDPI Construction. Aspects specific to beluga whales are analyzed here.

Sheet and Pile-driving

Belugas occur seasonally in the Beaufort Sea (Section 3.2.4.1). They have been sighted in the Proposed Action Area (Aerts et al., 2008) and occasionally occur near Northstar Island and Endicott (Aerts et al., 2008; Streever and Bishop, 2013). However, most beluga whales occur in deep water along the continental shelf break, and therefore would be spatially removed (Clarke et al., 2015a) from project-related effects, which would be contained within waters shoreward of the barrier islands.

Several audiogram studies completed on belugas (e.g., Awbrey, Thomas and Kastelein, 1988; Castellote et al., 2014; Johnson, McManus, and Skaar, 1989; White et al., 1978) indicate their functional hearing range overlaps with the frequencies and levels of sounds produced by island construction (Table 4.3.4-5, Figures 4.3.4-8 and 4.3.4-10). While sound source levels from impact pile-driving/pipe-driving could exceed Level A harassment thresholds (Table 4.3.4-1, Figure 4.3.4-12) portions of the frequencies produced would be too low to be detectable by belugas (Figure 4-3-4-12). Studies at Northstar, which is farther offshore/closer to the migratory path of belugas than the proposed LDPI, found impact pile driving during the open-water season did not produce received levels of 223 dB re 1 μ Pa SPL at any location in the water (Blackwell et al., 2004). Furthermore, belugas should leave and avoid areas where peak or cumulative sound levels are great enough to cause injury. Therefore vibratory sheet-driving noise levels should not reach PTS Thresholds (Table 4.3.4-1, Figure 4.3.4-12). In addition, pile-driving noise would attenuate rapidly in the shallow environment of Foggy Island Bay, reaching median background levels within a few kilometers. Those few beluga whales present to be exposed to noise up to 148 dB_{RMS} in the 5-55 Hz range, from impact and/or vibratory sheet pile-driving during proposed LDPI construction, would likely respond by avoiding the area. Because beluga whales primarily use mid- to high-frequency sounds to communicate and locate prey, masking by pile-driving is not anticipated (Gales, 1982) and could only occur over a limited portion of the frequency range audible to beluga whales.

In the Canadian Beaufort Sea, beluga whales were seen within several feet of an artificial island. During the island's construction, belugas were displaced from the immediate vicinity of the island but not from the general area (Fraker, 1977).

SLR (2017) found the distance to the interim behavioral thresholds (Level B Harassment) for vibratory sheet driving and impact pile-driving were 290 m and 90 m under ice respectively, and up to 17.5 km (within the barrier islands) and 2.25 km in open water respectively. Of these, only impact pile-driving/pipe-driving in open water have the potential for creating a PTS (SLR, 2017). The distances from the Proposed LDPI to interim behavioral thresholds from impact pipe-driving were 11 m under ice, and up to 400 m in open water. For injury thresholds (Level A Harassment) the distances from the Proposed LDPI and the NMFS acoustic thresholds for PTS are listed in Table 4.3.4-8.

Due to the low likelihood PTS effects from vibratory sheet-driving and impact pile-driving on belugas out to 3 km, the low numbers of beluga whales that have been observed in Foggy Island Bay, and the lack of potential population-level effects, vibratory sheet-driving should have a negligible level of effects on beluga whales. With the implementation of mitigations from Appendix C (C-3 Exclusion Zones / Monitoring), those effects would be lessened, but not below a negligible level of effects.

Vessel Traffic

Beluga whales are generally responsive to vessels, altering call types, frequencies, and rates and moving rapidly away from ships (e.g., Finley et al., 1990; Lesage et al., 1999). The level of response of belugas to vessels is thought to be partly a function of habituation (USDOC, NMFS, 2012b).

Sound levels produced by small and large vessels can exceed the Level B threshold for belugas (Table 4.3.4-1, and 4.3.4-7; Figures 4.3.4-4 and 4.3.4-8). However, studies suggest that TTS and PTS thresholds for belugas may be much higher. Finneran et al. (2005) noted only 18 percent of exposures to a sound exposure level of 195 dB re $1\mu\text{Pa}^2$ resulted in measurable TTS in beluga whales, and exposure of belugas to 208 dB failed to induce PTS (Finneran et al., 2002). While studies at Northstar indicate that sound source levels from hovercraft may also exceed Level B harassment thresholds (131-133 dB re $1\mu\text{Pa}$ @ 65 m) (Blackwell and Greene, 2005; Blackwell et al., 2009), the noise produced by this mode of transport is substantially less than standard support vessels, and less likely to impact belugas (Table 4.3.4-7). SLR (2017) modelled the vessel and hovercraft noises associated with the Proposed Action (Figure 4.3.4-9 and Table 4.3.4-7), and found the noises could exceed the interim behavioral threshold for beluga whales out to 2.2 km for vessels and 95 m for hovercraft. Vessel noises initially exceeded the TTS threshold (Figure 4.3.4-9); however, vessel noise quickly dropped below the TTS threshold in the frequency spectrum and attenuated to the interim behavioral noise threshold within 2.2 km, where they remained. Furthermore only a fraction of the noise produced is capable of producing any sort of injury to beluga whales (TTS), and none of the noise occurs at noise levels breaching the PTS injury threshold (Figure 4.3.4-9). Figure 4.3.4-10 shows the noise produced by vessel traffic could cross the interim behavioral response threshold (Level B Harassment) at the lower end of the noise spectrum audible to beluga whales and could be audible out to 1.5 – 2.2 km (SLR, 2017).

Individual belugas that encounter vessel traffic associated with proposed LDPI construction would likely respond by avoiding the area; physical impacts are not anticipated, particularly because vessel noise is continuous and belugas would detect and avoid areas where sound exposure levels exceed tolerable limits.

Appendix C describes mitigation measures derived from lease stipulations, design features and BMPs the operator committed to, and requirements and BMPs that other agencies typically require (sections C-1 to C-3). BOEM's conclusions regarding impacts assume implementation of, and compliance with, the mitigation measures described in sections C-1 through C-3. Particularly relevant measures include those required by NMFS (see section C-3) that mitigate the effects of vessel traffic.

Vessel strikes are discussed further in Section 4.3.4., and are not expected during the Proposed Action because of slow vessel transit speeds, the low likelihood of whales occurring within the Proposed Action Area, and the ability of whales to maneuver out of the path of slow-moving vessels. For these reasons the effects of vessel traffic on beluga whales is expected to be negligible.

Aircraft Traffic

While the frequency ranges of aircraft overlap with the ranges audible to beluga whales (Figure 4.3.4-8), the transmission of in-air sound through the aquatic environment is brief and much of it deflected by the water's surface (Section 4.3.4, Underwater Noise). Furthermore, most tones produced by aircraft are below the Level B harassment threshold (Table 4.3.4-1, Figures 4.3.4-4 and 4.3.4-8); decibels at the sound source may exceed this threshold but cetaceans would not typically be in close enough proximity to aircraft as to be exposed to these levels. More likely, any behavioral response to aircraft traffic would be due to presence.

Aircraft traffic associated with the Proposed Action would be inshore of the barrier islands, far from the continental shelf break habitat where most belugas occur during the open-water season (Section 3.2.4.1). Belugas have occasionally been recorded near the Proposed Action Area and nearby existing

oil and gas infrastructure (Aerts et al., 2008; Streever and Bishop, 2013) and individuals could be disturbed or displaced by project-related air traffic.

Most belugas do not display much discernible response to occasional, single passes by low-flying helicopters ferrying people and equipment to offshore operations at altitudes above 150 m (500 ft.) (Richardson and Malme, 1993). Paternaude et al. (2002) recorded reactions of bowhead and beluga whales to a Bell 212 helicopter and Twin Otter fixed-wing aircraft during four spring seasons (1989-1991 and 1994) in the western Beaufort Sea. Responses were more common to the helicopter than to the fixed-wing aircraft and included immediate dives, changes in heading, changes in behavioral state, and apparent displacement of belugas (Paternaude et al., 2002). Similar reactions were observed by the authors from the fixed-wing aircraft: The authors noted that responses were seen more often when the helicopter was below 492 ft. (150 m) altitude and at a lateral distance of less than 820 ft. (250 m) and when the Twin Otter was below 597 ft. (182 m) altitude and at a lateral distance of less than 820 ft. (250 m).

SLR (2017) modeled helicopter noise production (Figures 4.3.4-9 and 4.3.4-10) show helicopter noises associated with the proposed action would not pass any behavioral (Level B Harassment) or injury (Level A Harassment) thresholds established by NMFS (2016a). The beluga whale audiograms depicted in Figure 4.3.4-9 show helicopter noises should remain undetectable or barely detectable to beluga whales submerged in the water using the dB_{PEAK} metric.

Appendix C describes mitigation measures derived from lease stipulations, design features and BMPs the operator committed to, and requirements and BMPs that other agencies typically require (sections C-1 to C-3). BOEM's conclusions regarding impacts assume implementation of, and compliance with, the mitigation measures described in sections C-1 through C-3. Particularly relevant measures include those required by NMFS (see section C-3) that mitigate the effects of aircraft. For these reasons the effects of aircraft operations on belugas should be negligible since so few belugas have ever been observed in the vicinity of the proposed LDPI, and because of the overall lack of observed effects of aircraft operations on them.

Habitat Alteration

The LDPI footprint would compromise approximately 24 acres of seafloor that could serve as potential foraging habitat for beluga whales. However, most beluga whales remain near the ice front and the continental shelf break during summer (Clarke et al., 2015a), north of the Proposed LDPI.

Overall the permanent removal of this habitat would have a negligible level of effects beluga whales since the affected area would be a barely measurable fraction of potential beluga whale habitat.

Pipeline Installation

Beluga whales would not be directly impacted by pipeline installation because they are absent from the Proposed Action Area during winter and spring when the pipeline would be installed. Furthermore, the seafloor acreage affected by pipeline installation constitutes only a minute portion of the foraging habitat available to belugas and is in shallow water, far inshore of the primary areas where belugas feed. Therefore, pipeline installation would have a negligible level of effects on beluga whales.

Facilities Construction

The majority of facilities construction would occur during winter months, when beluga whales are absent from the Proposed Action Area (Section 3.2.4.1). Facilities construction during the open-water season could impact belugas with the presence of aircraft and marine traffic. The effects of aircraft and vessel operations were discussed in proposed LDPI Construction, and any aspects specific to facilities construction that have not previously been addressed are discussed below.

In addition to aircraft, crew boat, and ground traffic, facilities construction would be supported by barge and tug traffic (Hilcorp, 2015). Barge traffic could affect belugas if they occurred within the transit corridor between West Dock, Endicott SDI, and the proposed LDPI. Late season barge traffic, could disturb some belugas during the fall migration, but only if those whales were inside the barrier islands.

Whales react most noticeably to erratically moving vessels with varying engine speeds and gear changes and to vessels in active pursuit (USDOC, NMFS, 2012a). Barges and tug boats execute quick changes in course or speed slowly, and normally travel at slower speeds than smaller support boats to compensate for steering differences. Because of the inability of barges and tugboats to perform sudden heading changes, belugas are less likely to overtly respond to them.

Generally whales are likely to avoid being within 1-4 km of barges, though a few whales might not react until a vessel <1 km away (USDOI, MMS, 2002). As previously described, such effects should involve a few whales, who would respond with small deflections around or away from the vessel. In a recent Biological Opinion for a seismic survey in Foggy Island Bay, NMFS estimated number of marine mammal exposures to vessel noise ≥ 120 dB to be zero (USDOC, NMFS, 2014). Marine mammal monitoring by industry during the last few years detected 19 belugas in the area in 2014 (July-August), and 5 belugas in 2015 (9-19 July) near the Proposed LDPI site (Smultea et al. 2014, Cate et al. 2015), and passive acoustics detected belugas using the area on 5 different days in 2015 (6 July – 22 Sept) (Frouin-Mouy, Zeddies, and Austin 2016).

Given the small number of whales that could be exposed and the types of reactions belugas have with vessel traffic, no population-level effects to beluga whales should occur. For these reasons, facilities construction should have a negligible level of effects on beluga whales. Additionally, by implementing mitigations from Appendix C (C-3), the effects of large and small vessel traffic, air traffic, and construction noises on belugas would be even further reduced.

Drilling Operations

Noise from drilling operations could impact beluga whales, displacing them from the area around the Proposed LDPI. Many of these impacts were previously discussed (e.g., Proposed LDPI Construction, Facilities Construction), so only those aspects specific to drilling that have not previously been addressed are discussed below.

Responses of beluga whales to drilling operations are described in Richardson et al. (1995) and summarized here. In the Mackenzie Estuary during summer, belugas have been seen regularly within 328 to 492 ft. (100 to 150 m) of artificial islands (Fraker 1977a, b; Fraker and Fraker, 1979).

In spring, migrating belugas showed no overt reactions to recorded drilling noise (<350 Hz) until within 656 to 1,312 ft. (200 to 400 m) of the source, even though the sounds were measurable up to 3.1 mi away (5 km; Richardson et al., 1991). During another drilling noise playback study, overt reactions by belugas within 164 to 984 ft. (50 to 300 m) involved increased swimming speed or reversal of direction of travel (Stewart et al., 1983). Figure 4.3.4-9 compares the audiograms of captive beluga whales with the sound signature from drilling operations at Sandpiper Island, and the modeled drilling noise from the Proposed LDPI (SLR, 2017). The comparison indicates drilling operations from Sandpiper Island, and those modeled for the Proposed LDPI, were below the harassment criteria thresholds established by NMFS (2016a) (Figures 4.3.4-4, 4.3.4-9, and 4.3.4-10; Table 4.3.4-4). Whereas the Proposed LDPI is in shallow water approximately 6 meters deep, Sandpiper Island was in 15 meters of water, an environment that would have allowed greater noise propagation, which is consistent with the differences between the two sound signatures in Figure 4.3.4-9.

The short reaction distances are probably partly a consequence of the hearing sensitivity of belugas at low frequencies (Richardson et al., 1995). Belugas are the cetacean species most likely to experience

impacts from drilling noise because small numbers have been observed inside the barrier islands in Foggy Island Bay (Section 3.2.4.1). However, in general, very few belugas are expected to approach the Proposed Action Area.

As with Northstar (USDOC, NMFS, 2012b), the low source levels and rapid attenuation of drilling sounds from artificial islands in shallow water makes the noise inaudible to beluga whales (Figure 4.3.4-9), which makes masking an impossibility.

The overall level of effects of drilling operations and noise on beluga whales would be negligible; however with the Exclusion Zones / Monitoring mitigation described in Appendix C, beluga whales would be protected from residual or chronic effects from drilling noise, lowering the overall level of effects slightly but not below a negligible level of effects.

Transportation

Construction and drilling operations would occur concurrently for several years (Table 2-4). The number of vessel trips would increase during this period, which would result in greater potential for disturbance and displacement of whales out to distances of 2.2 km (Table 4.3.4-7). Once construction is complete, the number of marine vehicle trips would decrease; a reflection of the reduced need for vessel support during drilling operations (Table 2-4). This reduction would decrease potential effects of vessel traffic on whales. Impacts from marine traffic are discussed further in Proposed LDPI Construction and Facilities Construction.

Air traffic would occur at a greater frequency during drilling than during construction (2 trips per day during drilling vs. 1-2 trips per day during construction) (Table 2.1.5-2). During the 2 year period when drilling and construction activities may overlap, up to 4 trips per day could occur (Table 2.1.5-2). Correspondingly, the potential for disturbance or displacement of belugas from aircraft overflights once drilling operations commence would be comparable or higher than during the pre-drilling construction period.

Noise associated with support vessels is expected during drilling and would likely have a negligible physiological level of effects on beluga whales within 0.2 mi (0.32 km) of vessels (Table 4.3.4-5), but could elicit behavioral effects out to 2.2 km (Table 4.3.4-7). Effects from small vessels could include displacement/avoidance, and limited masking, but only if a beluga were to enter an area ensounded above 120 dB re 1 μ Pa, and in the necessary frequency range (Figures 4.3.4-1, 4.3.4-2, 4.3.4-4, 4.3.4-9, and 4.3.4-10; Tables 4.3.4-1, 4.3.4-2, 4.3.4-4, 4.3.4-5, and 4.3.4-7). Beluga whales have exhibited greater responses to a moving sound source (e.g., airgun activity on a moving vessel) than to a stationary sound source (NMFS, 2015). Scheifele et al. (2005) observed shipping noises caused belugas to vocalize louder in the Saint Lawrence Estuary. The acoustic behavior of that beluga population was also studied in the presence of ferry and small boat noise by Lesage et al. (1999), who observed more persistent vocal responses among whales exposed to the ferry noise than small boat noise. Lesage et al. (1999) found the reduction in calling rate may reduce communication efficiency, which is critical to a gregarious species; however, the gregarious nature of belugas necessitates maintaining short distances between group members, which alleviates some of the masking issues. The conclusion of Lesage et al. (1999) found a noise source would have to be very close to limit communication within a group of beluga whale. For these reasons, and the small number of beluga whale observations in Foggy Island Bay, the level of effects of vessel traffic from the Proposed Action on beluga whales should be negligible. By implementing mitigations measures from Appendix C, such as posting PSOs onboard vessels, reducing vessel speed, and avoiding marine mammals, the level of effects to beluga whales would be further reduced.

Production Operations

Production-related activities focus on the operation and maintenance of facilities and equipment. Operations would continue to be supported by resupply via ice roads and, to a lesser extent, summer

barges (at an estimated 10 trips per year). Aerial surveillance would be conducted of the pipeline corridor (Hilcorp, 2015, Sections 5.2.3 and 7.10) and vessel-based surveys would be performed to inspect for any damage to the island and offshore pipeline (Hilcorp, 2015, Section 6.2).

With one exception (vessel-based surveys, discussed later in this section), the types of potential impacts to beluga whales from production operations would be the same as those from drilling operations; however, the likelihood of occurrence would be relatively less, since fewer personnel would be needed once construction and drilling are complete. A reduction in personnel would result in relatively fewer aircraft and vessel trips for crew transport and resupply (Hilcorp, 2015, Tables 5-3, 5-4, and 5-5).

During the open water season, vessels were the main contributors to the underwater sound field at Northstar (Blackwell and Greene, 2006). It is likely that these would also be the primary sound source during production operations at the proposed LDPI. Other sounds would include noise from generators (Figure 4.3.4-12), process operations (e.g., flaring, seawater treatment, oil processing, gas injection), and proposed LDPI lighting, all of which are continuous noise that contribute to overall operational sounds at artificial gravel islands (USDOC, NMFS, 2012a). In a recent Biological Opinion the NMFS concluded production operations at Northstar would not produce incidents of TTS or PTS among cetaceans (USDOC, NMFS, 2012a). Potential impacts on belugas from Production Operations at the Proposed LDPI should be less than those of Northstar since beluga whale observations near the Proposed LDPI is in an area generally unused by cetaceans (Section 3.2.4.1).

Personnel from production platforms in Cook Inlet, Alaska, reported belugas within 30 ft. (9 m) of some drilling platforms, and the noises did not seem to disturb those belugas (Gales, 1982; McCarty, 1982). Beluga whales are regularly observed near the Port of Anchorage and the extensive dredging/maintenance activities that operate there (USDOC, NMFS, 2003). In that area, flare booms might attract belugas, possibly because the flares attract salmon. Similar changes to predator-prey relationships would be unlikely under the Proposed Action since the beluga stock mostly feeds in deeper waters near the shelf break, and typically only a few individuals occasionally enter nearshore waters (USDOC, NMFS, 2012b). In a 2012 environmental assessment for ongoing production operations at Northstar, the NMFS determined routine production activities would have minimal impact on belugas (USDOC, NMFS, 2012b), and it is expected the impacts from production operations at the Proposed LDPI would have even fewer effects.

Effects of sonar noise on belugas could involve behavioral (Figure 4.3.4-7) or physiological effects (Figure 4.3.4-6); however, side-scan sonar produces high frequency noise (Section 4.3.4) that attenuate rapidly and are unlikely to be detected by most belugas because it consists of highly focused, directed streams of noise, and because most belugas reside in waters over the continental shelf break during the open water season (Section 3.2.4.1). During passive acoustic monitoring of a 2015 open-water season geohazard survey in Foggy Island Bay belugas were detected in the area on a few days only, and were not detected throughout most of that season (Frouin-Mouy, Zeddies, and Austin, 2016). Consequently, it is possible, though unlikely; a few belugas could be disturbed and displaced by geohazard survey noise. Due to the low numbers of beluga whales in the area impacts to the any beluga whale stock would be negligible, as would the overall level of effects on beluga whales would be negligible. By implementing the mitigations described in Appendix C, such as Exclusion Zones / Monitoring, those effects would be even further reduced.

Decommissioning

Decommissioning would have no effect on beluga whales because they are absent from the Proposed Action Area during winter and spring when decommissioning would occur.

Bowhead Whales

Ice Road Construction and Use

Ice road construction and use would have no effect on bowhead whales because they are absent from the Proposed Action Area during winter and spring when ice roads would be constructed and used.

Mine Site Development

Mine site development would have no effect on bowhead whales because they are absent from the Proposed Action Area during winter and because mine activities would occur onshore.

Proposed LDPI Construction

Most proposed LDPI construction would have negligible levels of effect on bowhead whales because it would occur during winter and spring when bowheads are absent from the Proposed Action Area (Section 3.2.4.1). However, installation of slope protection around the LDPI would occur between May and August during the first summer of the Proposed Action, and this has the potential to impact bowhead whales should they occur in the vicinity. Aspects specific to bowhead whales are analyzed here. Slope shaping and armament installation would create potential zones of behavioral disturbance between 880 and 1260 m from the source, and zones of PTS risk < 10 m from the noise source (SLR 2017).

Sheet/Pile/and Pipe-driving

The specific auditory sensitivity of bowhead whales and other baleen whales have not been directly measured due to difficulties in maintaining mysticete whales in captivity, lack of trained test subjects, etc.; however, relevant anatomical and behavioral evidence indicates they are specialized for low frequency hearing, with some directional hearing ability (Section 4.3.4, Table 4.2.4-1; Ketten, 2000; Richardson et al., 1995). The assumed functional hearing range of bowheads includes the frequencies and decibel levels of sounds produced by pile-driving (Figure 4.3.4-2, Table 4.3.4-5).

The beginning of the slope armor installation would overlap temporally with the bowhead whale spring migrations into the Canadian Beaufort Sea (in mid-May through mid-June, Section 3.2.4.1); however, the spring migration occurs over the continental shelf break, well offshore of the Proposed Action Area. In a recent Biological Opinion for maintenance construction at Northstar, the NMFS determined noise from construction and operational activities (including pile-driving) would not likely be detectable far enough offshore to be heard by spring-migrating whales; if any noises were audible to the whales at that distance, they would be weak and unlikely to elicit behavioral reactions (USDOC, NMFS, 2012a).

Bowhead whales do not typically start their westward fall migration until late August when the LDPI slope protection installation would be complete. It is possible that a few bowhead whales leaving early on their westward fall migration could be impacted by the noise associated with this activity; the fall migration occurs closer to shore than does the spring migration, especially in years of low sea-ice (Section 3.2.4.1). Bowhead whales generally do not migrate inside of the barrier islands; however, individuals have been occasionally observed shoreward of the islands and at lagoon entrances (Section 3.2.4.1). Most sound from proposed LDPI construction activities would be unlikely to affect the few whales that could occur in lagoon entrances or inside the barrier islands due to the shallow-water environment, and lower decibel levels (Figure 4.3.4-12 and 4.3.4-13). Additionally, construction would mostly occur during winter when whales are absent from the Beaufort Sea such that most noises from construction activities could not surpass the interim behavioral disturbance thresholds (Figure 4.3.4-13) or injury thresholds (Figure 4.3.4-12). And finally, the barrier islands would prevent much construction noise from being transmitted seaward of the Proposed Action Area because sound propagates poorly through land (Richardson et al., 1995; USDO, MMS, 2002; SLR, 2017).

During the construction of artificial islands and other oil-industry facilities in the Canadian Beaufort Sea in late summers of 1980–1984, bowhead whales were at times observed as close as 0.5 mi (0.8 km) from the construction sites (Richardson et al., 1985, 1990). During these periods, bowheads generally tolerated playbacks of low-frequency construction and dredging noise at received broadband levels up to about 115 dB re 1 μ Pa (Richardson et al., 1990). At received levels higher than about 115 dB, some avoidance reactions were observed. Bowheads reacted in only a limited and localized way (if at all) to construction of Seal Island, the precursor of Northstar (Hickie and Davis, 1983). Greene et al. (2008) noted noises from sheet pile driving radiated 3 km (1.6 mi) before reaching 120 dB levels (Table 4.3.4-5).

SLR (2017) found the distance to the interim behavioral thresholds (Level B Harassment) for vibratory sheetpile driving and impact pile-driving were 290 m and 90 m under ice respectively, and up to 17.5 km (within the barrier islands) and 2.25 km in open water respectively. Of these, only impact pile-driving/pipe-driving in open water have the potential for creating a PTS (SLR, 2017), though the most likely effects would be a TTS from such activities (Figures 4.3.4-12 and 4.3.4-13). The distances from the Proposed LDPI to interim behavioral thresholds from impact pipe-driving were 11 m under ice, and up to 400 m in open water. For injury thresholds (Level A Harassment) the distances from the Proposed LDPI and the NMFS acoustic thresholds for PTS are listed in Table 4.3.4-8.

For these reasons the level of effects of pile-driving on bowhead whales would be negligible because of the recurring lack of bowheads observed in Foggy Island Bay, the sound propagation characteristics of sheet and pile driving in the Beaufort Sea and the demonstrated behavioral responses of bowhead whales to such activities. With the mitigations described in Appendix C (C-4.3.1 Exclusion Zones / Monitoring), the impact of those effects would be lessened, but not below a negligible level of effects.

Vessel Traffic

Bowhead whales react most noticeably to erratically moving vessels with varying engine speeds and gear changes and to vessels in active pursuit (USDOC, NMFS, 2012b). Avoidance reactions by bowheads sometimes begin as subtle alterations in whale activity, speed and heading as far as 2.5 mi (4 km) from the vessel. Consequently, the closest point of approach is farther from the vessel than if the cetacean had not altered course. Bowheads sometimes begin to swim actively away from approaching vessels when they come within 1.2–2.5 mi (2–4 km). If the vessel approaches to within several hundred meters, the response becomes more noticeable, and whales sometimes change direction to swim perpendicularly away from the vessel path (Richardson and Malme, 1993; Richardson et al., 1985, 1995).

As with belugas, sound levels produced by small and large vessels can exceed bowhead whale Level B and Level A harassment thresholds, respectively (Table 4.3.4-1, Figure 4.3.4-4). Vessel noise is concentrated at low-frequencies (Section 4.3.4, Table 4.3.4-1) and therefore would be more impactful to bowhead whales than to belugas because bowhead hearing sensitivity is thought to be greatest at lower frequencies. Vessel noise could result in physical injury if a bowhead whale were exposed to sound source levels because they exceed TTS onset thresholds for low-frequency cetaceans (Table 4.2.4-2). However, such a scenario is implausible because bowheads would detect and avoid areas where continuous sound exposure levels exceed tolerable limits. Vessel noise and presence more likely would elicit behavioral responses as described below.

Individual bowheads that are sensitive to vessel noise or presence could flee from vessels supporting proposed LDPI construction; they would usually stop within minutes after the vessel passed, but could remain scattered for a longer period (Koski and Johnson, 1987; Richardson and Malme, 1993). Multiple studies have reported that after disturbance and displacement by vessels, bowheads may return to a disturbed area within several days (e.g., Koski and Johnson, 1987; Thomson and

Richardson, 1987); however, the impacts of repeated disturbance from vessels on bowhead whale habitat use are less well known (USDOC, NMFS, 2012). More likely some whales could exhibit subtle changes in their surfacing and blow cycles, while others appear to be unaffected. Bowheads actively engaged in social interactions or mating may be less responsive to vessels (USDOI, MMS, 2002). Acoustic studies at Northstar indicate that in late summer and early autumn 2001, a small number of bowhead whales in the southern portion of the fall migration corridor were affected by industrial noise output by facility activities, which was predominantly vessel noise (USDOC, NMFS, 2012a). Although it is not entirely clear whether the whales responded merely by changing calling rates, by deflection, or both, a behavioral response to the anthropogenic noise at Northstar occurred.

In general, bowhead whales appear to avoid structures, such as offshore gravel islands, if support vessels are around the structure (USDOI, MMS, 2002). Migrating bowhead whales whose paths are deflected offshore by no more than a few kilometers would not, in most cases, incur biologically significant effects. A deflection by (at most) a few kilometers is well within the range of normal variability in the offshore distances of migrating bowhead whales (USDOC, NMFS, 2012a).

Vessel strikes are discussed in Section 4.3.4., and are not expected during the Proposed Action because of slow vessel transit speeds (see Appendix C), the low likelihood of whales occurring within the Proposed Action Area, and the ability of whales to avoid slow-moving vessels.

For these reasons the effects of vessel traffic on bowhead whales is expected to remain negligible. Implementation of the mitigations described in Appendix C would further reduce those effects.

Aircraft Traffic

While the frequency ranges of aircraft overlap with the ranges audible to bowheads (Figure 4.3.4-1, 4.3.4-2; Table 4.3.4-1), the transmission of in-air sound through the aquatic environment is brief and much of it deflected by the water's surface (Section 4.3.4). Furthermore, most tones produced by aircraft are below the Level B harassment threshold (Table 4.3.4-1 and Figure 4.3.4-4); decibels at the sound source may exceed this threshold but cetaceans would not typically be in close enough proximity to aircraft as to be exposed to these levels. More likely, any behavioral response to aircraft traffic would be due to presence.

There is little likelihood of project-related air traffic over bowhead whales since flight corridors would be between the shore and the proposed LDPI. Bowhead whales migrate west in waters north of Foggy Island Bay; however, individuals have been occasionally been recorded at lagoon entrances and shoreward of barrier islands in the Beaufort Sea (Section 3.2.4.1) and a few could be exposed to project-related aircraft traffic.

Individual bowhead whales affected by aircraft traffic are expected to exhibit brief, behavioral responses. In Paternaude et al.'s (2002) study, when bowhead whales did display discernible reactions to aircraft, reactions included abrupt dives, breaching, and short surfacing periods. Helicopters were more likely to elicit responses than fixed-wing aircraft (Paternaude et al., 2002). In a recent Biological Opinion for activities at Northstar, the NMFS determined that even if several bowhead whales did react to a single aircraft overflight, the whales' reaction would be brief and of no long-term consequence to the population (USDOC, NMFS, 2012a). For this reason the effects of aircraft operations on bowhead whales should be negligible. Furthermore, Appendix C describes mitigation measures derived from lease stipulations, design features and BMPs the operator committed to, and requirements and BMPs that other agencies typically require (sections C-1 to C-3). BOEM's conclusions regarding impacts assume implementation of, and compliance with, the mitigation measures described in sections C-1 through C-3. Particularly relevant measures include those required by NMFS (see section C-3) that mitigate the effects of aircraft traffic. By implementing a mitigation requiring a minimum altitude of 1,000 ft., as described in C-3, any effects to bowhead whales would be even further reduced.

Habitat Alteration

The LDPI footprint would compromise approximately 24 acres of seafloor that could serve as potential foraging habitat for gray whales, and to a lesser extent bowhead whales. However, the abundance of boulders and rocks on the seafloor, and the shallow depths near the LDPI likely limits the actual value of the area as a benthic foraging area for large mysticete whales. The rocky substrate would make cratering the sea floor problematic for large whales and the shallow depths would limit the body orientation options available for feeding whales. To feed on benthos in such an area vertically-oriented feeding would be impossible, so any whale attempting to feed on the sea floor would be limited to making horizontal gouges into the rocky substrate, which would likely reduce feeding efficiency.

Overall the permanent removal of this habitat would have negligible levels of effect on bowhead whales since the affected area would be a small fraction of the marine habitat, and most would remain unvisited, and unused by bowhead whales.

Pipeline Installation

Bowhead whales would not be directly impacted by pipeline installation since they are absent from the Proposed Action Area during winter and spring when the pipeline would be installed. Furthermore, the seafloor acreage affected by pipeline installation constitutes a small fraction of the foraging habitat available to them, and is in waters shallower than bowheads like to frequent. Therefore, pipeline installation would have a negligible level of effects on bowhead whales.

Facilities Construction

The majority of facilities construction would occur during winter months, when bowhead whales are absent from the Proposed Action Area (Section 3.2.4.1). Facilities construction could impact bowheads with the presence of aircraft and marine traffic during the open-water season. Such impacts were discussed previously in proposed LDPI Construction; aspects specific to facilities construction that have not previously been addressed are discussed below.

In addition to aircraft, crew boat, and ground traffic, facilities construction would be supported by barge and tug traffic (Hilcorp, 2015). Barge traffic could affect bowhead whales if they occurred within the transit corridor between West Dock, Endicott SDI, and the proposed LDPI, and barge traffic after 25 August could disturb some bowheads during the fall migration.

Whales react most noticeably to erratically moving vessels with varying engine speeds and gear changes and to vessels in active pursuit (USDOC, NMFS, 2012a). Barges and tug boats execute quick changes in course or speed slowly, and normally travel at slower speeds than smaller support boats to compensate for steering differences. Because of the inability of barges and tugboats to perform sudden heading changes, belugas are less likely to overtly respond to them.

Generally bowhead whales are likely to avoid being within 1-4 km of barges, though a few might not react until a vessel is less than <1 km away (USDOI, MMS, 2002). As previously described, such effects are expected to involve few whales that would react with small deflections from the vessel, and no population-level effects to beluga whales could occur. Likewise, noise from barges and tug boats should not produce any TTSs or PTSs (Figure 4.3.4-4) among bowhead whales (Onset TTS: 213 dB Peak SPL/PTS 219 dB Peak SPL; Table 4.3.4-3), due to the avoidance distances bowheads show to larger vessels.

Another issue to consider is the lack of observations of bowhead whales in Foggy Island Bay, especially near the proposed LDPI, by airborne and vessel surveys (Clarke et al., 2015a; Cate et al. 2015, Smultea et al. 2014), and a passive acoustics survey that detected no bowhead whale presence in the area (Frouin-Mouy, Zeddies, and Austin 2016).

For these reasons facilities construction should have a negligible level of effects on bowhead whales. By implementing mitigations from Appendix C such as, speed limits, and the use of PSOs to detect and avoid marine mammals, the effects of Facilities Construction on bowhead whales would be lessened, but not below a negligible level of effects. In a recent Biological Opinion for a seismic survey in Foggy Island Bay, NMFS concluded that the estimated number of marine mammal exposures to vessel noise ≥ 120 dB would be zero (USDOC, NMFS, 2014).

Drilling Operations

Drilling operations could impact bowhead whales via disturbance and displacement from anthropogenic noise and from the presence of aerial and marine traffic. Many of these impacts were previously discussed (e.g., proposed LDPI Construction, Facilities Construction), so only those aspects specific to drilling that have not previously been addressed are discussed below.

Playback, modeling, and simulation studies have shown bowhead whales begin showing behavioral responses to low-frequency industrial sounds when received levels exceed 115-120 dB re 1 μ Pa (Richardson et al., 1990, 1995; Ellison et al. 2016). The overall received level of drilling sound from Northstar Island generally diminished to 115 dB within 1 km (0.62 mi; Blackwell et al., 2004). For this reason any reactions by bowhead whales to drilling at the proposed LDPI should be highly localized and involve few whales (USDOC, NMFS, 2012a). As previously stated under the Impact Producing Factors heading, there is overlap between the frequency bands occupied by drilling noise and the audibility range for mysticete whales (LF Cetaceans) (Figure 4.3.4-2; Table 4.3.4-1); however, the drilling noise would not be sufficient to produce a TTS or PTS among bowhead whales (Table 4.3.4-2; Figure 4.3.4-4), nor should any incidents of level A Harassment occur (Table 4.3.4-4; Figure 4.3.4-4). Some incidents of Level B Harassment might occur out to a distance of 6 km (4 mi.) or less from the proposed LDPI (Table 4.3.4-5); however the shallow depths in the area, along with the consistent lack of bowhead observations from aerial (Figure 3.2.4-8, 3.2.4-10, and 3.2.4-11), and vessel-based platforms, and passive acoustics monitoring suggests bowhead whales avoid Foggy Island Bay, Alaska (Clarke et al., 2015a; Cate et al. 2015 et al. 2015, Smultea et al. 2014, Frouin-Mouy, Zeddies, and Austin 2016). Consequently no bowhead whales should be affected by drilling at the proposed LDPI; however due to their ESA-protected status, we should assume a few bowhead whales could experience Level B Harassment in any given year, especially after considering a single bowhead sighting at Tern Island, as reported by Nuiqsuit Whalers (Fig 3.3.3-3).

Bowhead whales migrate to and from the Eastern Beaufort Sea in the spring and fall, using a migration corridor well to the north of the proposed LDPI (Figure 3.2.4-7, and 3.2.4-9), so it is unlikely drilling noise would have any noticeable effect on migrating bowheads. During the 2005 fall bowhead migration past Northstar bowhead whales did migrate a little farther north than usual, but subsequent analyses revealed the modification in their migration route was due to environmental conditions, not noise from Northstar, though they reduced their vocalizations until passing west of the island, and a fraction of whales slightly shifted their travel routes to the north in years when noise levels from Northstar were above ambient (Blackwell et al. 2006; Blackwell et al. 2008; Richardson et al. 2012). Because of the proposed LDPI location, water depth, and distance of proposed LDPI from the bowhead whale fall migration route, the effects of noise on bowheads are expected to be less than that determined for the Northstar development project.

The overall level of effects of drilling operations and noise on bowhead whales would be negligible; however with the C-4.3.1. Exclusion Zones / Monitoring mitigation described in Appendix C, bowhead whales would be protected from residual or chronic effects from drilling noise, lowering the overall level of effects slightly but not below a negligible level of effects.

Transportation

Construction and drilling operations would occur concurrently for several years (Table 2-4). The number of vessel trips would increase during this period, which would result in greater potential for disturbance and displacement of whales. Once construction is complete the number of marine vehicle trips would decrease; a reflection of the reduced need for vessel support during drilling operations (Table 2-4). This reduction would result in decreased potential effects of vessel traffic on whales. Impacts from marine traffic are discussed further in proposed LDPI Construction and Facilities Construction.

Aircraft traffic would support Proposed Action activities during drilling at a greater frequency than during construction activities (2 trips per day during drilling vs. 1-2 trips per day during construction) (Table 2.1.5-2), and the effects of air traffic were described earlier. When drilling and constructions overlap, up to 4 trips per day during the two years when construction and drilling activities overlap (Table 2.1.5-2). Correspondingly, the potential for disturbance or displacement of whales from aircraft overflights once drilling operations commence would be comparable or higher than during the pre-drilling construction period. As detailed in proposed LDPI Construction, impacts from aircraft noise and presence would be short-term and produce at most behavioral responses.

Vessel traffic during construction of the Proposed LDPI would occur during the open-water season; however, marine mammal monitoring reflects a dearth of bowhead whale sightings in Foggy Island Bay (Figure 3.2.4-8; 3.2.4-9; 3.2.4-10). Large vessels would not be used to move personnel and materials to the Proposed LDPI, due to shallow water depths, boulder patch, and grounding risks closer to shore. Most small vessels (<85 m) produce noise at around 175 dB re 1 μ Pa (Figs 4.3.4-7, and 4.3.4-8), which is below the TTS (224 dB re 1 μ Pa)/PTS (230 dB re 1 μ Pa) thresholds for mysticete whales (Table 4.3.4-2, and 4.3.4-4; Figure 4.3.4-9), with a noise radius exceeding the behavioral threshold for the low-frequency cetacean functional hearing group out to about 200 to 2200 m from the vessel (Tables 4.3.4-5 and 4.3.4-7). In the unlikely event of bowhead whales encountering a vessel associated with the proposed action, the most likely effects to the whale would be the detection and avoidance of the vessel. The ensuing level of effects on bowhead whales would be negligible since no injurious or population-level effects would occur.

Reducing vessel speeds below 10 knots would be an additional mitigation that would further lessen chances of vessel strikes to bowhead whales by providing vessels and whales more reaction time to avoid strikes; while lessening the potential impact force and trauma severity to whales if a strike were to occur. This measure has been used successfully to protect north Atlantic right whales, a species anatomically and mechanistically similar to bowheads (Vanderlaan and Taggart, 2007; 79 FR 34245, June 16, 2014; Silber and Bettridge, 2012). By implementing the mitigations described in Appendix C, such as posting PSOs onboard vessels, avoiding marine mammals, and reducing vessel speed, the resulting impacts would be reduced, but not below a negligible level of effects on bowhead whales.

Production Operations

Production-related activities focus on the operation and maintenance of facilities and equipment. Operations would continue to be supported by resupply via ice roads and, to a lesser extent, summer barges (at an estimated 10 trips per year). Aerial surveillance would be conducted of the pipeline corridor (Hilcorp, 2015, Sections 5.2.3 and 7.10) and vessel-based surveys would be performed to inspect for any damage to the island and offshore pipeline (Hilcorp, 2015, Section 6.2).

With one exception (vessel-based surveys, discussed later in this section), the types of potential impacts to beluga, bowhead, and gray whales from production operations would be the same as those from drilling operations; however, the likelihood of occurrence would be relatively less since fewer personnel would be needed after construction and drilling are completed. A reduction in

personnel would result correspondingly fewer aircraft and vessel trips for crew transport and resupply (Hilcorp, 2015, Tables 5-3, 5-4, and 5-5).

During production, Hilcorp would use aerial surveys of the pipeline coupled with vessel-based bathymetric and side-scan sonar surveys of the LDPI and offshore pipeline to monitor for damage to infrastructure (Hilcorp, 2015, Section 7.2.4, Table 7-5). The vessel-based surveys, conducted during the open-water season, would involve using a remote operated vehicle, multi-beam bathymetry, a single-beam echo sounder, and/or sidescan sonar to inform the operator of strudel scour evidence and trends (Section 2.4.7.1, Hilcorp, 2015, Section 6.2).

Monitoring studies conducted since 2000 at Northstar are indicative of the types of impacts to bowhead whales from production at artificial islands in the U.S. Beaufort Sea (e.g., Blackwell and Greene, 2006; Blackwell et al., 2009). These reports indicate that effects from production operations on whales traveling near the southern (proximal) edge of the bowhead whale migration corridor would likely be subtle. Possible deflections during the fall migration are not likely to be injurious to individual animals or their population. While many feeding areas are dynamic and may change location from year to year, Native hunters have reported the Kaktovik area as a traditional feeding area for bowhead whales. Monitoring the bowhead whale migration, as they pass the Northstar oil production facility in the Beaufort Sea, has not found evidence of any such shifts to the migration corridor, although localized displacement has been observed (USDOC, NMFS, 2012a). Even were they to occur, it is unlikely these impacts would prevent the survival and recovery of this species, as production operations would not be expected to affect more than a very small portion of the migration corridor through the Alaskan Beaufort Sea.

While the frequencies produced by side-scan sonar are outside of the range of audibility of bowhead whales, it is possible that individual bowheads could be disturbed by vessel noise and traffic associated with the biennial geohazard surveys (see proposed LDPI Construction for a detailed description of vessel impacts to bowhead whales). However, bowheads have continued to travel to the eastern Beaufort Sea each summer despite seismic exploration in their summer and autumn range for many years (Richardson et al., 1985) and their population has grown substantially during this time. Furthermore, acoustic monitoring during a geohazard survey in Foggy Island Bay found that the sound produced by survey vessels and sub-bottom profilers did not substantially alter the soundscape at ranges greater than 500 m from the sound sources (Frouin-Mouy, Zeddies, and Austin, 2016). In any event, the proposed surveys would occur in summer (July through late August) when most bowhead whales are commonly feeding in the Mackenzie River Delta, Canada (USDOC, NMFS, 2015). Therefore it is expected that vessel-based surveys would have a negligible level of effects on bowhead whales. By incorporating the mitigations described in Appendix C (C-4.1.3.; C-4.3.1.), those effects would be lessened, but not below a negligible level of effects.

Decommissioning

Decommissioning would have negligible effect on bowhead whales because they are absent from the Proposed Action Area during winter and spring when decommissioning would occur.

Gray Whales

Ice Road Construction and Use

Ice road construction and use would have negligible levels of effect on gray whales since they are absent from the Proposed Action Area during winter and spring when ice roads would be constructed and used.

Mine Site Development

Mine site development would have negligible levels of effect on gray whales because they are absent from the Proposed Action Area during winter and because mine activities would occur onshore.

Proposed LDPI Construction

Most proposed LDPI construction would not impact gray whales because it would occur during winter and spring months when these species are absent from the Proposed Action Area (Section 3.2.4.1). Installation of the proposed LDPI's slope protection would occur between May and August during the first summer of the Proposed Action and has the potential to impact whales should they occur in the vicinity. The primary impact producing factors associated with slope protection would be noise from pile-driving, vessels, and aircraft, as well as the presence of aircraft and vessels. These factors are discussed in depth in Section 4.3.4 Underwater Noise. Only factors specific to gray whales are analyzed here.

Sheet/Pile/and Pipe-driving

As with bowhead whales, the auditory sensitivity of gray whales has not been directly measured but anatomical characteristics of gray and other baleen whales indicates they are adapted for low frequency hearing (Section 4.3.4, Table 4.3.4-1; Ketten, 2000; Richardson et al., 1995); a range that encompasses the frequencies and decibel levels of sounds produced by pile-driving (Figure 4.3.4-2, Table 4.3.4-5). A typical migrating gray whale tolerates steady, low-frequency industrial sounds at received levels up to about 120 dB re 1 μ Pa (Malme et al., 1984), or higher-level sounds if the sound source is offset to the side of the migration route (Tyack and Clark, 1998).

Gray whales are uncommon to scarce in the Beaufort Sea during the open-water season (Figs 3.2.4-12, and 3.2.4-13), and have not been documented in the Proposed Action Area, though they periodically occur in the Western Beaufort Sea and a few records exist showing them in the eastern U.S. Beaufort Sea (Section 3.2.4.1). Individual gray whales, if present in the Proposed Action Area, could be exposed to noise from pile-driving during proposed LDPI construction, but only during the open water season. It is possible that impact and vibratory pile driving may mask some calls produced by gray whales but the short-term duration of pile-driving events, the rapid attenuation of sound in the shallow marine environment and the limited area affected would make the likelihood of masking (U.S. Navy, 2014; SLR, 2017). Most likely no gray whales would occur near Foggy Island Bay, much less in the vicinity of the Proposed LDPI, and they usually avoid areas where sound exposure levels reach intolerable levels (USDOC, NMFS, 2012b).

For the onset of behavioral effects SLR (2017) calculated vibratory sheet pile-driving, impact sheet pile-driving, and impact pipe-driving would have their maximum behavioral disturbance threshold radii at 12,000/1,700/and 300 m respectively. SLR (2017) likewise found the maximum distance from impact sheet pile-driving to the onset of a PTS was less than 10 meters from the source with respect to SPL_{PEAK} , and at up to 1,940 m using the SEL metric. As with impact sheet pile-driving, the maximum distance to the PTS onset threshold for vibratory sheet pile-driving and impact pipe-driving were 50 and 870 meters respectively. With impact sheet pile-driving during the open water season a theoretical potential for a PTS to occur exists, but only if a gray whale remained within 770-1,220 meters from the noise source throughout an entire work day. Likewise a gray whale would have to remain within 870 meters of pipe-driving for a full work day in order for a PTS to occur.

Because of the lack of gray whale sightings in Foggy Island Bay and the area around the Proposed LDPI, and the set of criteria necessary for pile or pipe driving to have injurious effects on mysticete whales, pile and pipe-driving associated with the Proposed LDPI should have a negligible level of effects on gray whales. By implementing the mitigations described in Appendix C (C-4.3.1. Exclusion Zones / Monitoring), those effects would be lowered, but not below a negligible level of effects.

Vessels

Reactions of gray whales to vessel presence and noise are summarized in Richardson et al. (1995) and Malme et al. (1989); however, most records focus on the relative movements of whales and ships and

little to no specific information regarding vessel noise impacts is available (Moore and Clarke, 2002). At summer feeding grounds in Russia, whales fled from large vessels approaching within 350-550 m but exhibited no discernible response when the vessels were farther away (Bogoslovskaya et al., 1981 in Moore and Clarke, 2002). Migrating gray whales would change course to avoid vessels at 200-300 m (Wyrick, 1954). Smaller vessels may or may not elicit responses, including avoidance, abandonment of localized habitat areas (Bryant et al., 1984; Jones and Swartz, 1984) or conversely, attraction (Dahlheim et al., 1984). Figure 4.3.4-10 shows the vessel noise levels modeled by SLR (2017) would exceed the 120 dBRMS noise threshold for behavioral disturbances in frequencies mostly below 150 Hz (NMFS, 2016a)

The potential impacts of vessel noise to gray whales are similar to those described for bowhead whales since both bowhead and gray whales have low-frequency hearing (Table 4.2.4-1). Because they often occur closer to shore than bowhead whales, gray whales could be exposure to vessel noise during proposed LDPI construction; however, they are scarce in the Beaufort Sea, and have never been documented in the Proposed Action Area, so the relative likelihood of one or more gray whales being affected by vessel traffic during proposed LDPI construction should be low.

For these reasons the overall level of effects of vessel traffic on gray whales should be negligible. By implementing mitigations described in Appendix C (C-4.1.3. Vessels In Vicinity Of Whales), those impacts would be lessened, but not below a negligible level of effects.

Aircraft Traffic

While the frequency ranges of aircraft overlap with the ranges audible to gray whales (Figure 4.3.4-1, 4.3.4-2, 4.3.4-10; Table 4.3.4-1), the transmission of in-air sound through the aquatic environment is brief and much of it deflected by the water's surface (Section 4.3.4; SRC 2017). Furthermore the noises produced by aircraft are below the Level B harassment threshold (Table 4.3.4-1 and Figure 4.3.4-10); decibels at the sound source may exceed this threshold but cetaceans would not typically be in close enough proximity to aircraft as to be exposed to these levels. More likely, any behavioral response to aircraft traffic would be due to presence.

Gray whales are scarce in the Beaufort Sea during the open-water season, none have been recorded in the Proposed Action Area, though they typically occur more often in the Western Beaufort Sea (Section 3.2.4.1, Clarke et al. 2015). Individual gray whales, if they were present in the Proposed Action Area, could be exposed to aircraft traffic, albeit with little actual effect to the whales.

Reported gray whale reactions to aircraft are varied and seem related to ongoing whale behavior and aircraft type and altitude. Migrating whales changed their swimming course and sometimes slowed down in response to underwater playbacks of a Bell 212 helicopter (estimated altitude = 100 m), but proceeded to migrate past the transducer (Malme et al., 1984). Migrating gray whales did not react overtly to a Bell 212 helicopter at >425 m altitude, occasionally reacted when the helicopter was at 305-365 m, and usually reacted when it was below 250 m (Southwest Research Associates, 1988). Reactions noted in that study included abrupt turns or dives or both. Green et al. (1992 in Richardson et al., 1995) observed that migrating gray whales rarely exhibited noticeable reactions to a straight-line overflight by a Twin Otter at 197 ft. (60 m) altitude. As with bowhead whales, the effects of aircraft operations on gray whales would most likely be negligible; however implementation of the mitigation requiring a 1,000 ft. minimum altitude (Appendix C: C-4.2. Aircraft Traffic in vicinity of whales or seals) would further reduce the potential for impacts, though those effects would remain within negligible levels.

Habitat Alteration

The LDPI footprint would compromise approximately 24 acres of seafloor that could serve as potential foraging habitat for gray whales. However, the abundance of boulders and rocks on the seafloor, and the shallow depths near the LDPI likely limits the actual value of the area as a benthic

foraging area for large mysticetes. The rocky substrate would make cratering the sea floor problematic for large whales and the shallow depths would limit the body orientation options available for feeding whales. To feed on benthos in such an area vertically-oriented feeding would be difficult if not impossible, so any whale attempting to feed on the sea floor would be limited to making horizontal gouges into the rocky substrate, which would reduce feeding efficiency, and possibly injure whales.

Overall the permanent removal of this habitat would have negligible levels of effect on gray whales since the affected area would be a small fraction of marine habitat, and most likely would not be used by gray whales.

Pipeline Installation

Gray whales would not be directly impacted by pipeline installation because they are absent from the Proposed Action Area during winter and spring when the pipeline would be installed. Furthermore, as with proposed LDPI Construction, the seafloor acreage affected by pipeline installation consists of a tiny fraction of gray whale foraging habitat, and much of it is in water depths too shallow for gray whales to crater the sea floor or otherwise feed. For these reasons pipeline installation would have negligible levels of effect on gray whales.

Facilities Construction

The majority of facilities construction would occur during winter months, when gray whales are absent from the Proposed Action Area (Section 3.2.4.1). Facilities construction could impact them with the presence of aircraft and marine traffic during the open-water season. Such impacts were discussed previously in proposed LDPI Construction; aspects specific to facilities construction that have not previously been addressed are discussed below.

In addition to aircraft, crew boat, and ground traffic, facilities construction would be supported by barge and tug traffic (Hilcorp, 2015). Barge traffic could affect gray whales using an area within the transit corridor between West Dock, Endicott SDI, and the proposed LDPI, and barge traffic.

Gray whales react most noticeably to erratically moving vessels with varying engine speeds and gear changes and to vessels in active pursuit (USDOC, NMFS, 2012a). Barges and tug boats cannot execute quick changes in course or speed slowly, and normally travel at slower speeds than smaller support boats to compensate for steering differences. Because of the inability of barges and tugboats to perform sudden heading changes, gray whales are less likely to overtly respond to them.

As with bowhead whales, gray whales are likely to avoid being within 1-4 km of barges, though a few might not react until a vessel is less than <1 km away (USDOI, MMS, 2002). As previously described, such effects are expected to involve a few whales that would react with small deflections from vessels, and no population-level effects to gray whales could occur. Likewise, noise from barges and tug boats should not produce any TTSs or PTSs (Figures 4.3.4-10) among gray whales due to the avoidance distances gray whales afford to larger vessels.

Another issue to consider is the lack of observations of gray whales in Foggy Island Bay, especially near the proposed LDPI, by airborne and vessel surveys (Clarke et al. 2015a), and marine mammal monitoring by industry in recent years which detected no gray whales in the vicinity of the proposed LDPI (Smultea et al. 2014, Cate et al. 2015). Likewise passive acoustic monitoring detected no gray whales in the area (Frouin-Mouy, Zeddies, and Austin 2016).

For these reasons the effects of large vessel traffic on gray whales should be negligible. By implementing mitigations from Appendix C (C-4.1.3 Vessels In Vicinity Of Whales), such as speed limits, the use of PSOs to detect and avoid marine mammals, and avoidance protocols, etc. the effects of large vessel traffic on gray whales would be lessened, but not below a negligible level of effects.

Drilling Operations

Drilling operations could impact gray whales via disturbance and displacement from anthropogenic noise and from the presence of aerial and marine traffic. Many of these impacts were previously discussed (e.g., Proposed LDPI Construction, Facilities Construction), so only those aspects specific to drilling that have not previously been addressed are discussed below. Figure 4.3.4-10 shows the low levels of drilling noise previously measured at the now defunct Sandpiper drilling Island and the modeled drilling noises at the Proposed LDPI, in Foggy Island Bay, Alaska. Both sound signatures were well below the 120 dB_{RMS} Behavioral Disturbance threshold outlined by NMFS (2016a).

As with bowhead whales, playback studies suggest gray whales begin displaying overt behavioral responses to low-frequency industrial sounds when received levels exceed 110–120 dB re 1 μPa (Malme et al., 1984; Richardson et al., 1990, 1995a, 1995b). Due to anatomical and behavioral characteristics, drilling noise would affect gray whales in a manner consistent with what was described for bowhead whales. Gray whales are uncommon to scarce in different parts of the Beaufort Sea and like bowheads, none have been observed in the vicinity of the Proposed LDPI by aerial or vessel monitoring, or by passive acoustics (Clarke et al., 2015; Cate et al., 2015; Smultea et al., 2014; Frouin-Mouy, Zeddies, and Austin, 2016). For these reasons few, if any, gray whales should be affected by drilling at the Proposed LDPI, nor could population-level effects to the gray whale stock occur. For these reasons the overall level of effects of drilling operations and noise on gray whales would be negligible; however with the C-4.3.1. Exclusion Zones / Monitoring mitigation described in Appendix C, gray whales would be protected from residual or chronic effects from drilling noise, lowering the overall level of effects slightly but not below a negligible level of effects.

Transportation

Construction and drilling operations would occur concurrently for several years (Table 2-4). The number of vessel trips would increase during this period, which would result in greater potential for disturbance and displacement of whales. Once construction is complete the number of marine vehicle trips would decrease; a reflection of the reduced need for vessel support during drilling operations (Table 2-4). This reduction would result in decreased potential effects of vessel traffic on whales. Impacts from marine traffic are discussed further in proposed LDPI Construction and Facilities Construction.

Aircraft traffic would support Proposed Action activities during drilling at a greater frequency than during construction activities (2 trips per day during drilling vs. 1-2 trips per day during construction) (Table 2.1.5-2), and the effects of air traffic were described earlier. When drilling and constructions overlap, up to 4 trips per day during the two years when construction and drilling activities overlap (Table 2.1.5-2). Correspondingly, the potential for disturbance or displacement of whales from aircraft overflights once drilling operations commence would be comparable or higher than during the pre-drilling construction period. As detailed in proposed LDPI Construction, impacts from aircraft noise and presence would be short-term and produce at most behavioral responses.

Between 1999 and 2003, the California stranding network reported only four serious injuries or mortalities of gray whales caused by vessel strikes, and only one reported in Alaska (Allen and Angliss, 2013). Besides the low risk of vessel strikes, gray whales should be affected by vessel traffic and vessel noise in a manner similar to bowhead whales. Since gray whales are likely to avoid vessel traffic, and no collisions with vessels have been reported in the Arctic to date, and because of the scarcity of gray whales in the Beaufort Sea the potential for vessels associated with the proposed LDPI to affect gray whales is limited. Because of gray whale scarcity in Foggy Island Bay, and because those individuals would be familiar with vessels and likely avoid them, vessel operations would have a negligible level of effects this species. Implementation of Appendix C mitigations (C-4.1.3.; C-4.3.1.) would lower the potential level of effects to gray whales; however, the level of effects would still remain negligible.

Production Operations

Production-related activities focus on the operation and maintenance of facilities and equipment. Operations would continue to be supported by resupply via ice roads and, to a lesser extent, summer barges (at an estimated 10 trips per year). Aerial surveillance would be conducted of the pipeline corridor (Hilcorp, 2015, Sections 5.2.3 and 7.10) and vessel-based surveys would be performed to inspect for any damage to the island and offshore pipeline (Hilcorp, 2015, Section 6.2).

With one exception (vessel-based surveys, discussed later in this section), the types of potential impacts to beluga, bowhead, and gray whales from production operations would be the same as those from drilling operations; however, the likelihood of occurrence would be relatively less. Fewer personnel would be needed once construction and drilling are complete. A reduction in personnel would result in relatively fewer aircraft and vessel trips for crew transport and resupply (Hilcorp, 2015, Tables 5-3, 5-4, and 5-5).

During production, Hilcorp would use aerial surveys of the pipeline coupled with vessel-based bathymetric and side-scan sonar surveys of the LDPI and offshore pipeline to monitor for damage to infrastructure (Hilcorp, 2015, Section 7.2.4, Table 7-5). The vessel-based surveys, conducted during the open-water season, would involve using a remote operated vehicle, multi-beam bathymetry, a single-beam echo sounder, and/or sidescan sonar to inform the operator of strudel scour evidence and trends (Section 2.4.7.1, Hilcorp, 2015, Section 6.2).

There are no data on the reactions of gray whales to production activities similar to those that would occur under the Proposed Action (USDOC, NMFS, 2012b). Oil production platforms of a very different type have been in place off California for many years. Gray whales regularly migrate through that area (Brownell, 1971), but no detailed data on distances of closest approach or possible noise disturbance have been published. Oil industry personnel have reported seeing whales near platforms, and that the animals approach more closely during low-noise periods (Gales, 1982; McCarty, 1982). Playbacks of recorded production platform noise indicate that gray whales react if received levels exceed approximately 123 dB re 1 μ Pa—similar to the levels of drilling noise that elicit avoidance (Malme et al., 1984). A typical migrating gray whale tolerates steady, low-frequency industrial sounds at received levels up to about 120 dB re 1 μ Pa (Malme et al., 1984), and may tolerate higher-level sounds if the sound source is offset to the side of the migration path (Tyack and Clark, 1998). Also, gray whales tolerate repeated low-frequency seismic pulses at received levels up to about 163-170 dB re 1 μ Pa, and any noise above those levels commonly elicits avoidance. Since the reaction thresholds to both steady and pulsed sounds are slightly greater than for bowheads, one can assume reaction distances for gray whales would be less than those for bowheads (USDOC, NMFS, 2012b).

Despite seismic exploration, offshore drilling, naval operations, and tremendous amounts of shipping along the west coast of North America, gray whales continue migrating along their established routes (Appendix A in Malme et al., 1984). Concurrently the gray whale population has grown substantially once they became protected from commercial whaling, suggesting the level of effects from proposed surveys to both individuals and the greater population should remain negligible (USDOC, NMFS, 2015). Likewise, the construction and operation of drilling islands in the Beaufort Sea has had no identifiable adverse effects to gray whales. By implementing the mitigations in Appendix C (C-4.1.3.; C-4.3.1.), the effects of Production Operations could be lessened, but not below a negligible level of effects.

Decommissioning

Decommissioning would have negligible effect on beluga, bowhead, and gray whales because they are absent from the Proposed Action Area during winter and spring when decommissioning would occur.

Additional Proposed Mitigation

Vessels were found to be the predominant noise source during drilling and production operations at Northstar (Blackwell et al., 2004; USDOC, NMFS, 2012b). Investigations by BPXA found hovercraft use for Northstar transport resulted in a decreased number of elevated vessel noise ("vessel spikes") events (Blackwell and Greene, 2005; USDOC, NMFS, 2012b). Hovercraft produce less underwater sound than vessels, consequently the use of hovercraft in lieu of boats, when/if possible, would reduce the sound footprint of the Proposed Action (as depicted in Figure 4.3.4-9).

In studies of marine mammals responses to aircraft noise and presences, animals have consistently been more sensitive to helicopters than to fixed-wing aircraft (e.g., Greene et al., 1993 in Richardson et al., 1995; Paternaude et al., 2002; Southwest Research Associates, 1988 in Richardson et al., 1995). Helicopter produce louder noise than fixed-wing aircraft, so the use of fixed-wing aircraft in lieu of helicopters, when feasible, would reduce potential for disturbance to marine mammals from Proposed Action aircraft traffic (as depicted in Figure 4.3.4-9).

Oil Spills

Beluga, bowhead and, to a lesser extent, gray whales can occur in the vicinity of the Proposed Action Area during the open-water season (Section 3.2.4.1) and could potentially be affected by summer oil spills or winter spills after oil freezes into sea ice and releases into the water as the ice melts. Bowhead whales may be vulnerable particularly to oil-spill effects due to their use of ice edges and migration through leads where spilled oil may accumulate (Engelhardt, 1987). The bowhead whale spring migration across the Alaska Beaufort Sea occurs progressively farther offshore than the fall migration. Consequently bowhead whales would be less likely to contact spills in spring than in fall since they would be farther from the proposed LDPI or its pipeline. Beluga whales concentrate along the continental shelf break which, like the bowhead spring migration, is far offshore of the Proposed Action Area, reducing the potential that belugas would contact spilled oil. As nearshore foragers, gray whales tend to occur closer to coastlines; this would put them at compatibly great potential for contact with oil spills. However, gray whales occur only occasionally in the Beaufort Sea and are sparsely distributed, reducing the likelihood that a spill from the Proposed Action would contact individuals of this species.

Individual whales could encounter the spilled oil and experience direct effects through exposure, and possibly secondary effects through the ingestion of contaminated prey depending on the time of year the spill occurs. However, oil does not adhere to cetacean skin in the same way it does to the pelage of other marine mammals (Engelhardt, 1983; St Aubin, 1992). Consumption of contaminated prey and the reduction or mortality of local forage fish populations could create periods whereby prey would not be available for an undetermined time period. For example, the fish and invertebrate populations preyed on by beluga whales within the Action Area (i.e. shrimp, cephalopods, Arctic and saffron cod) are vulnerable to oil contamination (Sections 4.3.1 and 4.3.2).

A review of the environmental effects of the *Deepwater Horizon* spill (Beyer et al., 2016) demonstrated that the oil was toxic to a wide range of organisms, including marine mammals, causing a wide array of adverse effects such as reduced growth, disease, impaired reproduction, impaired physiological health, and mortality. For example, it is thought that exposure to oil from the *Deepwater Horizon* spill was a combined stress factor that reduced the health condition of bottlenose dolphins, making them more susceptible to pathogens and to cold-water stunning (Schwacke et al., 2014; Venn-Watson et al., 2015). Further detailed information on the physiological impacts of oil contact to marine mammals is presented in Section 4.3.4 Accidental Oil Spills.

Small

Small spills (<1,000 bbl) of refined oil could occur during construction, drilling, production, and decommissioning. Small spills of crude oil could occur during drilling and production.

Details are further discussed in Section 4.1.1.2, Small Oil Spills (<1,000 bbl), and in Appendix A. The majority of small spills would be contained on the proposed LDPI or landfast ice (during winter), and refined spills that reach the open water would evaporate and disperse within hours to a few days. For example, a 200 bbl refined oil spill during summer evaporates and disperses within 3 days. A 3 bbl refined oil spill during summer evaporates and disperses within 24 hours.

In the event that a small spill occurred, individual whales or their prey could come into contact with oil. If contact between oil and whales is made, the ensuing effects would most likely be sublethal, although mortalities among individual whales would be possible depending upon the spill size, severity, weathering processes, and the duration of exposure. However, because of the low number of whales in the area where small spills may occur and dissipate it is unlikely mortality would occur. Prey contamination from small spills would be localized and temporary because small refined offshore oil spills are expected to dissipate rapidly. Due to their small size, localized and temporary effects, and rapid weathering it is expected that small spills would have negligible effects to beluga, bowhead and gray whales.

Large

A large spill ($\geq 1,000$ bbl) could occur during drilling or production; however, the OSRA estimates that there is a 99.33% chance of no large spills occurring during the Proposed Action (Appendix A). Because large spills are of important concern, BOEM assumes a large spill could occur and conducts a large oil spill analysis for the development and production activities (Section 4.0 Accidental Oil Spills and Gas Release Estimation).

In the unlikely event of such an oil spill, the effects would be determined by the volume, trajectory, constituents, weathering, number of individuals contacted, and timing of the spill as well as the residence time of the oil in the environment (Helm et al., 2015). Prolonged exposure of large numbers of feeding whales concentrated in high prey density could be exposed to prolonged oil contact and experience moderate effects, including mortality of some individuals and impaired physiological function and reproductive capacity, ulcerations, etc. This scenario is considered very unlikely; however, if it should occur, could result in long-term adverse population-level effects, except among gray whales which are uncommon to scarce in the Beaufort Sea.

Oil-Spill Analysis

Detailed background on BOEM's OSRA process is provided in Appendix A. The OSRA model estimates the conditional and combined probabilities of a large spill contacting a geographic area (i.e., environmental resource area (ERA), land segment (LS), grouped land segment (GLS)) important to one or several species or species groups during a discrete amount of time. A list of whale ERAs can be found in Appendix A, Table A.1-3.

ERAs (no LSs or GLSs were identified for whales) analyzed in this section are those for which the conditional probability of large spill contact was found to be $\geq 5\%$ at any point within 360-days of a spill occurring. The conditional probabilities of those ERAs for which contact was $< 5\%$ can be found in Appendix A). The ERAs discussed in this section are:

- **ERA 25 (AK BFT Bowhead FM 4).** Part of the bowhead whale fall migration route through the Beaufort Sea, vulnerable to large spills from September through October; and
- **ERA 26 (AK BFT Bowhead FM 5).** Part of the bowhead whale fall migration route through the Beaufort Sea, vulnerable to large spills from September through October (Appendix A, Table A.1-3).

Maps showing the location of whale ERAs are presented in Appendix A.

Conditional Probabilities

The OSRA model calculates conditional probabilities (expressed as a percent chance) of a spill contacting identified whale ERAs. Conditional probabilities are based on the assumption that a large spill has occurred (for further explanation, see Appendix A). For a map of the hypothetical spill sources (proposed LDPI and pipeline) used for the oil-spill-trajectory analysis, see Appendix A, Map A-6.

Summer Spills. A large spill during summer (July 1 through September 30) could impact whales, particularly bowhead whales because they migrate westward through the Beaufort Sea in September and October and their fall migration occurs closer to shore than their spring migration (Section 3.2.4.1). The conditional probabilities of a summer large spill from the proposed LDPI or the pipeline contacting a whale ERA are presented in Table 4. 2.4-8. Bowhead whales are less likely to be directly impacted by a large spill that occurs late in the summer (e.g., late-September) because most whales would have migrated through ERAs 25 and 26 before the probability of contact to those ERAs is greater than zero (i.e., 30-days after the spill began, or late-October).

Table 4.3.4-9. Summer Conditional Probabilities of Large Spill Contacting a Whale ERA.

ERA	Source	1-day	3-day	10-day	30-day	90-day	360-day
25	LDPI	<0.5	1%	4%	5%	5%	5%
26	LDPI	<0.5	<0.5%	3%	5%	6%	6%

Winter Spills. A large spill during winter (October 1 through June 30) could impact whales if they were to encounter the spills during the latter half of the fall migration through the Beaufort Sea (Section 3.2.4.1). A large spill in during or after freeze up in winter would be difficult to clean up, and oil could become entrained in the ice, melting out in spring and contacting lead systems and marine waters where whales are seasonally present. However, the OSRA model found that the conditional probabilities of a large winter spill from the proposed LDPI or pipeline occurring contacting a whale ERA never rose above 1% (Appendix A, Table A.2-42). Thus, regardless of when in winter a large spill might occur, the potential for impacts to beluga, bowhead, and gray whale are exceedingly small.

Combined Probabilities

Combined probabilities differ from conditional probabilities in that there is no assumption that a large spill has occurred. Instead, combined probabilities reflect the chance of one or more large spills occurring over the life of the Proposed Action, and of any portion of that spill contacting any portion of a particular ERA. Combined probabilities do not factor in any cleanup efforts. For more background information, see Appendix A, Section A-2.

The OSRA model found the combined probabilities of a large spill occurring and contacting a whale ERA within 360 days to be <1%, regardless of whether the spill occurred during winter or summer months.

Oil Spill Response

The conditional or combined probabilities do not consider the effectiveness of spill response activities to mitigate large spills which could range from highly effective under ideal conditions to largely ineffective depending upon the specific circumstance. An oil-spill response plan would be required prior to drilling and production activities. Oil spill response can cause disturbance, and the use of dispersants could harm marine mammals or their prey.

Depending on the location of the spill, oil-spill response could take some time to begin. Oil spill response equipment is cached in Deadhorse and in Utqiagvik, about 150 mi (241 km) west of Deadhorse. Oil spill response personnel would be expected to work with NMFS on the management

of whales and seals in the event of a spill and to work with USFWS on walrus and polar bear management activities.

During oil spill response activities, oiled fish carcasses would be collected when feasible, which could lessen the risk of belugas ingesting oiled prey items. In some circumstances, oiled fish floating in broken ice and in open leads would be very difficult to locate and recover. Removal of all types of oiled carcasses (birds, seals, fish, and other mammals) is an important primary oil spill response activity. This removes a source of secondary poisoning to scavengers and predators.

Hazing may be very effective in the case of small spills or in relatively discrete areas. Most marine mammals would be likely to avoid the high level of activity associated with cleanup activities.

In general, cleanup activities could result in short or long-term displacement of whales and their prey from preferred habitats and increased human interactions and disturbance. Conversely, cleanup activities would likely decrease the likelihood that marine mammals may come into contact with oil by displacing them from oiled areas. These activities and their potential impacts to beluga, bowhead, and gray whales would not reach population-affecting levels; therefore oil spill response would have minor effects on beluga, bowhead, and gray whales.

Conclusion

The level of effects from the Proposed Action on all cetaceans would be negligible, and only from activities occurring during the open-water season. No routine activities associated with the Proposed Action would result in injury to cetaceans. Unplanned, accidental occurrences such as vessel strikes and oil spills could have negligible to moderate impacts depending upon the circumstances of an incident. By incorporating all of the mitigations described in Appendix C, the effects for all proposed activities would be kept at a negligible level of effects, regardless of variations in activity throughout the life of the Proposed Action.

4.3.4.1.2. Alternative 2 (No Action)

Under this Alternative, the Proposed Action would not be approved and the actions described would not take place. The status of the beluga, bowhead, and gray whales stocks in the U.S. Beaufort Sea would continue with current population trends. Alternative 2 would result in no additional impacts to beluga, bowhead and gray whales (Table 4.2.4-9).

4.3.4.1.3. Alternative 3 – proposed LDPI Relocation

Alternative 3 would relocate the proposed LDPI to one of two locations. Alternative 3A would place the proposed LDPI approximately 1 mi east of the Proposed Action site; Alternative 3B would place the proposed LDPI approximately 1.5 mi southwest of the Proposed Action site (Section 2.2.4). The ways in which aspects of the project would be affected in some cases differ between Alternative 3A and Alternative 3B; therefore each sub-alternative is discussed separately in comparison with the Proposed Action.

Alternative 3A: Relocate LDPI Approximately One Mile to the East

The increased water depth at Alternative 3A proposed island site (from 19 to 21 ft) would not increase the likelihood of project impacts to whales as it is too shallow to be useable habitat for these species. Alternative 3A would require 0.6 more acres of the seabed being used compared to the Proposed Action. However, this is negligible and irrelevant as the depth renders this habitat unusable for whales. Although winter construction of the proposed LDPI and associated pipeline would take longer than under the Proposed Action the potential impacts to whales would not change as these activities would occur in the winter when whales are absent from the area. However, the Alternative A3 site would require an increase from approximately 45 days to 70-80 days of drilling time in years 3-5, which could occur when whales are present in the vicinity of the Proposed Action Area. This

would increase the amount of time whales could be exposed to drilling noise. In addition, drilling at the Alternative 3A location would require a larger rig with more hydraulic horsepower, increasing from the proposed 2,100 hp drill rig to a 3,000 hp rig with an increased torque capability, and increased hookload capacity. This would increase the sound levels to which whales could be exposed.

Alternative 3B: Relocate LDPI Approximately 1.5 Miles to the Southwest

Alternative 3B site would relocate the proposed LDPI closer to shore compared to the Proposed Action. This could decrease impacts (possible boat strikes, vessel noise) from vessel traffic from the shore to the proposed LDPI. However, due to the shallow depth of the water it is unlikely that whales would occur between the shore and the site of Alternative 3B or the proposed site so there may not be a measurable impact reduction. The decrease in depth of water from the proposed site to the Alternative 3B site (from 19 to 17 ft) would have negligible levels of effect on the potential impact of the project on whales as it is not a useable depth for cetaceans. Alternative 3B requires 2.4 less inches of the seabed being used compared to the Proposed Action. This is negligible and irrelevant as the depth renders this habitat unusable for whales. Construction of the Alternative 3B LDPI site and associated pipeline would take less time than the Proposed Action; however, this would have no benefit to whales over the Proposed Action as this activity would occur in the winter when they are absent from the area. However, the Alternative 3B site would require an increase from approximately 45 days to 120 days of drilling time in years 3-5 which could occur when whales were present in the Action Area. This would increase the amount of time whales are exposed to drilling noise (for impacts from drilling noise to whales see analysis in the Proposed Action as well as discussion in IPFs for marine mammals). In addition, moving the proposed LDPI to Alternative 3B would require a larger rig with more hydraulic horsepower, increasing from the proposed 2,100 hp drill rig to a 3,000 hp rig with an increased torque capability, and increased hookload capacity. This would also increase the noise to which whales could be exposed.

Conclusion

The only clear difference in impacts for whales between the Proposed Action and Alternative 3 is that Alternative 3 would expose whales to longer periods of drilling noise; up to 35 days longer for the Alternative 3A site and 75 days longer for the Alternative 3B site. However, these impacts would still be negligible for the following reasons. Based on studies examining the impact from drilling at the Northstar Island it was found the higher-frequency peak, which was distinct enough to be used as a drilling "signature", was clearly detectable 5 km (3.1 mi) from the drill rig, but had fallen to background values by 9.4 km (5.8 mi). Few whales occur within 10km of the Liberty site (proposed and Alternatives 3A and 3B). Beyond that distance, measured levels were dominated by natural (or at least non-Northstar) sound or vibration. In addition, Northstar is constructed outside of the barrier islands whereas the sites (Proposed, Alternatives 3A and 3B) for the Liberty development are within the barrier islands. A location inside of the barrier islands would in all likelihood dampen sounds from drilling, decreasing the distance drilling sounds are detectable, and lessening impacts on whales outside of the barrier islands (where almost all sightings occur; Section 3.2.4.1) from drilling noise. Therefore the noise from drilling at Liberty would likely not propagate as far as that from Northstar. Based on distributions of beluga, bowhead, and gray whales in the Action Area (Section 3.2.4.1) it is likely very few beluga, bowhead or gray whales would be exposed to drilling noise so an increase in drilling time is a negligible impact. Therefore, impacts to beluga, bowhead and gray whales would be the same for Alternative 3 compared to the Proposed Action because these cetaceans would be impacted by the same impact producing factors and the same level of impact regardless of where the proposed LDPI is located in Foggy Island Bay (Table 4. 2.4-9).

4.3.4.1.4. Alternative 4 – Onshore Processing

Alternative 4 would relocate the processing facilities from the proposed LDPI to an onshore location (Section 2.2.5). Two options exist for onshore processing: use of an existing facility and construction

and use of a new facility. The ways in which aspects of the project would be affected differ between Alternative 4A and Alternative 4B, therefore each option is discussed separately in comparison with the Proposed Action.

Production operations not associated with process facilities operations would remain approximately the same for Alternative 4 as the Proposed Action. However, there are some differences which are discussed below in terms of impacts to cetaceans.

This alternative would not change the number of wells or length of time for drilling compared to the Proposed Action so impacts would whales from drilling would remain the same as the Proposed Action. However, without processing facilities on the proposed LDPI to separate and condition the reservoir gas for living quarters and drilling operations power generation, either diesel would need to be barged to the proposed LDPI or natural gas would need to be provided to the proposed LDPI via a pipeline - possibly from the shore based processing facility. If the barging diesel option is chosen this would increase vessel traffic between West Dock and Foggy Island Bay (Figure 2.1.1-2) where more cetaceans may be encountered which could impact whales with possible injury or mortality from boat strikes, and impacts from vessel noise and presence. If the pipeline option is chosen this would have no increased impact on whales because pipeline construction and installation would not overlap temporally with cetaceans.

Under Alternative 4 the size of the proposed LDPI would be smaller with processing facilities not located on site. As a result there could be less construction noise and activity. However, since construction is planned to occur February-March when whales are absent from the area there would no advantage to whales under Alternative 4. However, the amount of driven sheet pile wall installed around the proposed LDPI for slope protection would be less and impacts from pile driving would be reduced. This would lessen impacts to whales because this activity is scheduled to occur May-August when whales may be present. For further discussion on the impacts of pile driving on whales see analysis of the Proposed Action for proposed LDPI Construction.

Under Alternative 4 there is little to no substantial reduction in ice road construction compared to the Proposed Action. In addition, this activity is scheduled to occur December-April when whales are not typically present.

With processing facilities onshore, it is likely that a larger, more complex pipeline bundle would be needed to potentially supply natural gas and water to the proposed LDPI. Processed natural gas would be needed for gas lift operations and gas injection to support resource conservation efforts (produce more oil and leave less oil behind) with gas lift production operations and reservoir pressure maintenance though gas injection efforts. However, beluga, bowhead and gray whales would not be affected by onshore and offshore pipeline construction and installation because they are typically absent from the Proposed Action Area in January-May (Section 3.2.4.1) when these activities would occur.

The construction of a new processing facility onshore vs. offshore would have no impact to whales because all activities associated with the construction of a new facility would occur during the winter months when whales are not typically present in the area.

Under Alternative 4 there would be a marked reduction in equipment on the proposed LDPI compared to the Proposed Action which would reduce noise in the marine environment. However, under Alternative 4 it is likely that pumps would be needed to support pushing the multi-phase reservoir fluids from the proposed LDPI to a shore based processing facility via the flow-line so this would somewhat negate the noise reduction. Since impacts to whales from equipment on the proposed LDPI from the Proposed Action are already negligible, there would no benefit under Alternative 4 for this IPF.

Under Alternative 4 processing facility support personnel would be located onshore and not be located on the proposed LDPI which would reduce the total number of people located offshore. This would also reduce associated employee support facilities and needs required on the proposed LDPI. With processing facilities onshore, maintenance and personnel would also be relocated. As a result, the human footprint, maintenance work, and supply logistics (transportation) associated with the processing facilities would be removed from the proposed LDPI and directed to the onshore processing facility. This would lessen impacts to whales from noise and disturbance associated with human activity. It would also reduce the impact from transporting the processing employees between the mainland and the proposed LDPI. Since these impacts are already negligible for whales under the Proposed Action, the reduction in personnel on the proposed LDPI for Alternative 4 is not necessarily an advantage over Alternative. The reduction in employee support facilities offshore under Alternative 4 may mean less construction but this activity would occur in the winter when whales are typically absent.

Finally, during decommissioning, there would be less material to remove (sheet pile, process modules, and other reduced infrastructure assets) from the proposed LDPI if Alternative 4 is selected. This could reduce impacts to whales from noise and disturbance although this reduction would be not alter the overall level of impact from that determined for decommissioning activities in the Proposed Action.

The primary benefit to beluga, bowhead, and gray whales of onshore processing provided by Alternative 4 is that it would move potential impacts associated with construction of the processing plant and actual processing (noise, physical presence, and some spills associated with processing activities) farther away from the marine environment. There would be a reduction in noise and activity if processing was conducted onshore because there would be less construction (i.e., less pile driving, less barge trips) on the offshore proposed LDPI. In addition, if processing were onshore the offshore proposed LDPI would be smaller enabling a smaller footprint in the marine environment. However, there would still be sources of noise even with a processing facility onshore; i.e. pumps to push the multiphase hydrocarbons to onshore processing. In addition, there would still be noise from construction, drilling, and production activities from the offshore proposed LDPI.

In conclusion, impacts to beluga, bowhead and gray whales would be slightly less (i.e. less pile driving, less construction, less vessel trips) for Alternative 4 compared to the Proposed Action because noise occurrence would be reduced (although not necessary to lower levels). However impacts would still occur due to noise from construction and development of the proposed LDPI, drilling and production noise and noise from pumps associated with the multiphase flow needed for onshore processing. These impacts would still be considered negligible for activities associated with development and production, and accidental spills. Therefore, for whales, Alternative 4 has the same impact level as the Proposed Action (Table 4. 2.4-9).

4.3.4.1.5. Alternative 5 – Alternate Gravel Source

Alternative 5 would relocate the gravel mine to one of three locations (Section 2.2.6). This would affect the number and placement of ice roads and the footprint and levels activity at the mine site but would not alter the types or durations of activities during the open-water season. Therefore the types and level of impacts to beluga, bowhead, and gray whales from Alternative 5 would not differ from those described for the Proposed Action (Table 4.2.4-9).

Table 4.3.4-10. Alternatives 2-5 Gravel Mine Location and Impacts to Whales Compared to the Proposed Action.

Alternative	Disturbance or Displacement*	Habitat Loss or Alteration*	Overall Comparative Level of Impacts
2: No Action	less (none)	less (none)	less (none)
3A: proposed LDPI Relocation East	greater	same	same
3B: proposed LDPI Relocation Southwest	greater	same	same

Alternative	Disturbance or Displacement*	Habitat Loss or Alteration*	Overall Comparative Level of Impacts
4A: Onshore Processing at Existing Facility	less	less	same
4B: Onshore Processing at New Facility	less	less	same
5A: East Kad River Mine Site #2	same	same	same
5B: East Kad River Mine Site #3	same	same	same
5C: Duck Island Mine Site	same	same	same

Note: * Columns two and three display comparative impact levels by type of impact.

4.3.4.2. Pacific Walrus

4.3.4.2.1. The Proposed Action

Ice Road Construction and Use

Ice road construction and use would have negligible effect on Pacific walruses because they are absent from the Proposed Action Area during winter and spring (Section 3.2.4.3) when ice roads would be constructed and used.

Mine Site Development

Mine site development would have negligible effect on Pacific walruses because they are absent from the Proposed Action Area during winter (Section 3.2.4.3) and because they do not occur inland of the coastline.

LDPI Construction

Most proposed LDPI construction activities would not impact Pacific walruses because they would occur during winter and spring months when walruses are absent from the Proposed Action Area (Section 3.2.4.3). Installation of the proposed LDPI's slope protection would occur during the open-water season and has the potential to impact individual walruses should they occur in the vicinity. The primary impact producing factors associated with slope protection would be noise from pile-driving, and the noise and presence of aircraft and vessels. Sheet/Pile/and Pipe-driving

Kastelein et al. (2002) produced an underwater audiogram of a Pacific walrus and found the best range of hearing was 1 - 12 kHz (10 dB re 1 μ Pa from maximum sensitivity, which was 67 dB at 12 kHz). Sound measurements were modeled for impact and vibratory sheet and pipe-driving (SLR 2017; Section 4.3.4) and only impact sheet and pipe-driving have the potential to produce a TTS amongst marine mammals; however at no time did the modeled noise exceed the TTS Threshold of walruses (Figure 4.3.4-11) Figure 4.3.4-11 does show the frequencies produced by sheet pile exceed Behavioral Response (Level B Harassment) Threshold established by NMFS (2016a). For these reasons, if walruses occurred near the proposed LDPI while pile driving were occurring, they merely be exposed to sounds capable of eliciting behavioral responses, and insufficient to produce injuries.

Aircraft and vessel use would occur during proposed LDPI construction (Hilcorp, 2015), and the associated visual presence and sounds could temporarily disturb walruses to at least 15 to 67 meters (SLR 2017). Pacific walruses are highly mobile and likely to avoid moving vessels by diving or swimming away (Fay et al., 1984). Vessels associated with the Proposed Action would transit between either West Dock or Endicott SDI and the proposed LDPI. Vessels in the vicinity of the Proposed Action Area have a remote possibility of encountering an individual or small group (≤ 3) of walruses.

Aircraft travel between the proposed LDPI and Deadhorse and/or the Endicott SDI could disturb walruses, which are known to respond to in-air sound, particularly aircraft, (Brueggeman, 1990; Fay et al., 1984). SLR (2017) modeled the noise levels emanating from the helicopter listed in the Proposed Action and found the produced noise levels were below the audible threshold for walrus based on the audiogram created by Kastelien (2002).

Walrus have occasionally hauled out on Northstar Island and the Endicott Causeway and have been recorded in the waters around the Endicott and West Dock causeways (Streever and Bishop, 2014; USDOJ, USFWS, 2011). Repeated disturbance from vessel or aircraft traffic could cause individual walrus using habitat near Endicott or West Dock to abandon the area, which might have energetic costs and potentially separate calves from their mothers (Garlich-Miller et al., 2011), leading to calf fatalities. However, the area of potential disturbance would be extremely small in comparison to the available marine waters of the Beaufort Sea. In most cases, impacts to individual walrus from aerial and marine traffic would be limited to temporary displacement from the area of activity. Furthermore, the area sees frequent vessel and air traffic such that any walrus using these areas are likely habituated to anthropogenic activities.

Individuals or small groups of walrus, if present in the Proposed Action Area, could be exposed to underwater sound produced by crew transport vessels (12 trips per day during the open-water season) (Hilcorp, 2015, Table 5-3). Small vessels produce low-frequency sounds within the frequency range of walrus hearing (Figures 4.3.4-2, 4.3.4-7, and 4.3.4-10); however these sounds are expected to decay to 120 dB re 1 μ Pa within 15 m (SLR 2017). Any effects from vessel noise are likely to result in behavioral responses (e.g., swimming away from the sound source) and not injury.

The LDPI footprint would permanently remove approximately 24 acres of seafloor that could serve as potential foraging habitat for walrus. The permanent removal of this habitat would not impact walrus since benthic biomass in the nearshore Beaufort Sea is comparatively lower than in the Chukchi Sea, and because of the boulder patch which would provide poor foraging habitat for walrus. Furthermore, the seafloor acreage removed by construction of the proposed LDPI would be such a small fraction of the habitat available to walrus, that the population or any individuals would not be affected.

The completed proposed LDPI could provide a small amount of terrestrial habitat upon which walrus could haul out. Although they are uncommon in the Eastern U.S. Beaufort Sea, individual and small groups (2-3) walrus have been recorded hauled out on Northstar Island (USDOJ, USFWS, 2011).

The duration of potential for impacts from proposed LDPI construction would be less than one year and most potential impacts would be no more than short-term behavioral responses. Effects would be limited to a few individuals which could be minor in the case of impact sheet pile and pipe-driving, but negligible on the Pacific walrus population.

Pipeline Installation

Pacific walrus would not be directly impacted by pipeline installation because they are absent from the Proposed Action Area during winter and spring (Section 3.2.4.3) when the pipeline would be installed. Furthermore, as with proposed LDPI Construction, the seafloor acreage affected by pipeline installation is not quality walrus foraging habitat and constitutes only a minute portion of the foraging habitat available to walrus. Therefore, pipeline installation would have negligible effect on the Pacific walrus population.

Facilities Construction

The majority of facilities construction would occur during winter months, when walrus are not present in the Proposed Action Area (Section 3.2.4.3). Facilities construction could impact Pacific walrus via disturbance and displacement from the presence of foot, aerial, and marine traffic during the open-water season. These impacts have been discussed previously in proposed LDPI Construction; aspects specific to facilities construction that have not previously been addressed are discussed below.

Aerial and marine traffic to support facilities construction would continue at the same frequency and with the same potential impacts as described in proposed LDPI Construction. In addition to aircraft, crew boat, and ground traffic, facilities construction would be supported by barge and tug traffic (Hilcorp, 2015). The foot traffic occurring at the proposed LDPI during the open-water season would mostly occur inside of the berm on the island, and would not affect walrus.

Potential for impacts to Pacific walrus from facilities construction would occur intermittently over a 3-year and most potential impacts would be no more than short-term behavioral responses. Impacts would be limited to a few individuals and would have negligible effects on the Pacific walrus population.

Drilling Operations

The drilling noise produced at the Proposed LDPI would be below the minimum hearing threshold for Pacific Walrus at 200 meters from the island (SLR 2017, Figure 4.3.4-10) and so should have no effect on them. Actual drilling noise 450 m from the now defunct Sandpiper Island near the Proposed LDPI site were collected in 1985, and similarly below the hearing threshold for Pacific walrus (Figure 4.3.4-10; Miles Malme and Richardson 1987; Miles et al. 1986) at the island. . Drilling operations could impact Pacific walrus via disturbance and displacement from anthropogenic noise and from the presence of aerial and marine traffic. Many of these impacts have been discussed in previous sections (e.g., Proposed LDPI Construction, Facilities Construction); aspects specific to drilling operations that have not previously been addressed are discussed below.

Sound source levels that could be produced by drilling should not exceed the Marine Mammal Protection Act (MMPA) Level B harassment thresholds (Figures 4.3.4-4 and 4.3.4-10) identified for Pacific walrus by USFWS (Section 4.3.4) and could not reach Level A harassment thresholds for non-impulsive noise (SLR 2017). Drilling operations introduce the potential for a large spill to occur. Impacts of large spills to Pacific walrus are presented in Oil Spills – Large.

Construction and drilling operations would occur concurrently for several years (Table 2-4). The number of vessel trips would increase during this period, which would result in greater potential for disturbance and displacement of individual walrus. Once construction is complete the number of marine vehicle trips would decrease; a reflection of the reduced need for vessel support during drilling operations (Table 2-4). This reduction would result in decreased potential effects of vessel traffic on walrus. Impacts from marine traffic are discussed further in proposed LDPI Construction and Facilities Construction.

Aircraft traffic would continue to support project activities during drilling but at a greater frequency than during construction activities (2 trips per day during drilling vs. 1-2 trips per day during construction) (Table 2-5). When drilling and constructions overlap, up to 4 trips per day during the two years when construction and drilling activities overlap (Table 2.1.5-2; Figure 2-1). Correspondingly, the potential for disturbance or displacement of Pacific walrus from aircraft overflights once drilling operations commence would be comparable or higher than during the pre-drilling construction period. As detailed in proposed LDPI Construction, impacts from aircraft noise and presence would be short-term and produce at most behavioral responses.

Potential for behavioral effects to Pacific walrus from drilling operations would be present during the open-water seasons over a 2-year period, would amount to short-term behavioral responses (avoidance). Effectss would be limited to a few individuals and would be negligible.

Production Operations

Production-related activities focus on the operation and maintenance of facilities and equipment. Operations would continue to be supported by resupply via ice roads and, to a lesser extent, summer barges (at an estimated 10 trips per year). Aerial surveillance would be conducted of the pipeline

corridor (Hilcorp, 2015, Sections 5.2.3 and 7.10) and vessel-based surveys would be performed to inspect for any damage to the island and offshore pipeline (Hilcorp, 2015, Section 6.2).

With one exception (vessel-based surveys, discussed later in this section), the types of potential impacts to Pacific walrus from production operations would be the same or less than those from drilling operations; however, the likelihood of occurrence would be relatively less since fewer personnel would be necessary after construction and drilling are complete. A reduction in personnel would result in fewer aircraft, vessel, and hovercraft trips for crew transport and resupply (Hilcorp, 2015, Tables 5-3, 5-4, and 5-5).

During production, Hilcorp would use aerial surveys of the pipeline with coupled with vessel-based bathymetric and side-scan sonar surveys of the island and offshore pipeline to monitor for damage to infrastructure (Hilcorp, 2015, Section 7.2.4, Table 7-5). The vessel-based surveys, conducted during the open-water season, would involve using a remote operated vehicle, multi-beam bathymetry, a single-beam echo sounder, and/or sidescan sonar to inform the operator of strudel scour evidence and trends (Section 4.3.4 Geohazard Surveys; Hilcorp, 2015, Section 6.2). The relationship between Pacific walrus hearing and the use of echosounders, side-scan sonars, multi-beam echosounders, high resolution profilers are presented in Figure 4.3.4-7.

Details on the noise impacts of these types of vessel-based surveys to marine mammals are discussed in Section 4.3.4. Noises in the frequency range produced by sidescan sonar are within the upper hearing range of Pacific walrus (Table 4.3.4-1; Figure 4.3.4-7). While the presence of the bathymetry vessel and potential presence of a Remotely Operated Vehicle (ROV) could disturb and temporarily displace individual Pacific walrus, such equipment can have high source levels, the noise is tightly focused, and should not affect Pacific walrus.

The potential for impacts to Pacific walrus from production operation would be continuous each open-water season over a 22-year period. As stated previously, walrus that frequent this area are likely habituated to anthropogenic activities since active coastal oil and gas facilities occur to the east and west of the LDPI. Most potential impacts would be no more than short-term behavioral responses. Impacts would be limited to a few individuals and would have negligible effects on the Pacific walrus population.

Decommissioning

Decommissioning would have negligible effect on Pacific walrus because they are absent from the Proposed Action Area during winter and spring when decommissioning would occur.

Oil Spills

Individual Pacific walrus can occasionally occur in the Action Area during the open-water season and could be impacted by spills during that time. Walrus that come into contact with crude or refined oil could experience acute and long-lasting effects, including irritation to eyes, mouth, and mucus membranes, irritation and damage to respiratory organs from inhalation, and kidney and liver damage from ingestion of contaminated prey. Further detailed information on the physiological impacts of oil contact to marine mammals is presented in Section 4.3.4.

Small

Small spills (<1,000 bbl) of refined oil could occur during construction, drilling, production, and decommissioning. Small spills of crude oil could occur during drilling and production (Section 4.1).

In the event that a small spill occurred, individual Pacific walrus or their prey could come into contact with oil. However, a small spill is unlikely to contact Pacific walrus, even if it entered water bodies or wetlands, because walrus are extralimital in this area and occur only occasionally east of Harrison Bay and are sparsely distributed (Section 3.2.4.3). Additionally, most small spills assumed

to occur during the Proposed Action would be 2-3 bbl (with an average of 0-9 bbl spilled annually) and a 3-bbl refined oil spill evaporates and disperses within 24 hours during summer months (Section 4.1).

Summary. Small spills resulting from the Proposed Action would have negligible effects on Pacific walrus and their population, since walrus seasonally occur in the central and eastern U.S. Beaufort Sea during the open-water season. Considering this and their scarcity in the Beaufort Sea, even in the absence of containment and clean-up, small spills would evaporate and disperse quickly before walrus could contact the spilled materials. Existing spill responses (Alaska Clean Seas, 2016) would make the chance of a Pacific walrus contacting a small spill from the proposed LDPI so remote as to be discountable.

Large

A large spill ($\geq 1,000$ bbl) could occur during drilling or production; however, the OSRA estimates that there is a 99.33% chance of no large spills occurring during the Proposed Action (Appendix A). Because large spills are of important concern, BOEM assumes a large spill could occur and conducts a large oil spill analysis for the development and production activities (Section 4.1).

Detailed background on BOEM's OSRA process is provided in Appendix A. The OSRA model estimates the conditional and combined probabilities of a large spill contacting a geographic area (i.e., environmental resource area (ERA), land segment (LS), grouped land segment (GLS)) important to one or several species or species groups during a discrete amount of time. A list of Pacific walrus ERAs, LSs, and GLSs can be found in Appendix A, Table A.1-5.

For all walrus ERAs, LSs, and GLSs, the OSRA model found the conditional probability of large spill contact within 360 days to be $<1\%$, regardless of whether the spill occurred from the proposed LDPI or the pipeline or during winter or summer months. Because the conditional probability is $<1\%$, the combined probability of a large spill contacting a walrus ERA, LS, or GLS is also $<1\%$.

Summary. A large spill resulting from the Proposed Action is unlikely to contact individual Pacific walrus because they occur only occasionally in the U.S. Beaufort Sea. If an individual walrus contacted or ingested crude oil it could experience acute and chronic physiological impacts, up to and including mortality. However, the adverse impact to a single or few individual walrus would have negligible effects on the Pacific walrus population.

Oil Spill Response

Oil spill response activities would involve the use of vessels, aircraft, and other equipment, the presence and sounds of which can disturb and displace Pacific walrus as described for similar activities in previous sections (e.g., proposed LDPI Construction, Facilities Construction) and for oil spill response effects to other pinnipeds in the Proposed Action Area (Section 4.3.4.4). Because Pacific walrus are unlikely to occur in the vicinity of the Proposed Action Area, oil spill response activities would have negligible effects on the Pacific walrus population.

Summary

The effects from Proposed Action activities would result in an overall negligible level of impacts to Pacific walrus.

Additional Proposed Mitigation

As with many other species of marine mammals (Section 4.3.4), Pacific walrus generally are more sensitive to helicopters than to fixed-wing aircraft (78 FR 1942, January 9, 2013). The use of fixed-wing aircraft in lieu of helicopters when possible, as described in Section 4.3.4.1, would decrease the potential for disturbance to walrus as a result of the Proposed Action. Likewise the use of hovercraft, as recommended in Section 4.2.4.1, would decrease the maximum sound level generated by marine

support traffic. This would decrease the extent of the area ensounded by Proposed Action drilling and production operations, decrease the potential for noise exposure to any walrus near the proposed LDPI (see Figure 4.3.4-9), and thus reduce potential noise impacts to walrus.

4.3.4.2.2. Alternative 2 – No Action

Under Alternative 2, the No Action Alternative, the proposed development and production activities would not be approved and there would be no effect to Pacific walrus. The Pacific walrus population would continue with current population trends (Table 4.2.4-11).

4.3.4.2.3. Alternative 3 – proposed LDPI Relocation

Alternative 3 would relocate the proposed LDPI either approximately 1 mi east or 1.5 mi southwest of the site proposed under the Proposed Action. This would slightly alter the length of time required to deposit the gravel for the proposed LDPI's foundation (Section 2.1.3) but would not affect the general timing or duration of pile-driving activity. Therefore the types and level of impacts to Pacific walrus from Alternative 3 would not differ from those described for the Proposed Action (Table 4.2.4-11).

4.3.4.2.4. Alternative 4 – Onshore Processing

Alternative 4 would relocate the processing facilities from the proposed LDPI to either the existing Endicott SDI or to a new facility located near the Badami tie-in (Section 2.2.5). Both of these options would reduce potential for disturbance and displacement of walrus because proposed LDPI construction (and associated noise production) would be of shorter duration, and less vessel traffic would be needed to support facilities installation, and drilling and production operations. Pacific walrus could be disturbed or displaced from a localized area if construction of a dock were required to provide emergency support the onshore processing facility. However walrus are uncommon and sparsely distributed in the Proposed Action Area and impacts to one or a few individuals from dock construction activities and use would not alter the overall level of impacts to the Pacific walrus population anticipated under the Proposed Action (Table 4.2.4-11).

4.3.4.2.5. Alternative 5 – Alternate Gravel Source

Alternative 5 would relocate the gravel mine to one of three locations (Section 2.2.6). This would affect the number and placement of ice roads and the footprint and levels activity at the mine site but would not alter the types or durations of activities during the open-water season. Therefore the types and level of impacts to Pacific walrus from Alternative 5 would not differ from those described for the Proposed Action (Table 4.2.4-11).

Table 4.3.4-11. Alternatives 2-5 Gravel Mine Location and Impacts to Pacific Walrus Compared to the Proposed Action.

Alternative	Disturbance or Displacement*	Habitat Loss or Alteration*	Overall Comparative Level of Impacts
2: No Action	less (none)	less (none)	less (none)
3A: proposed LDPI Relocation East	same	same	same
3B: proposed LDPI Relocation Southwest	same	same	same
4A: Onshore Processing at Existing Facility	less	less	same
4B: Onshore Processing at New Facility	less	less	same
5A: East Kad River Mine Site #2	same	same	same
5B: East Kad River Mine Site #3	same	same	same
5C: Duck Island Mine Site	same	same	same

Note: *columns two and three display comparative impact levels by type of impact.

4.3.4.3. Bearded Seals

4.3.4.3.1. The Proposed Action

Ice Road Construction

Bearded seals would not be affected by ice roads, because they mostly migrate to the Bering Sea during winter. The segment of the bearded seal DPS that overwinters in the Beaufort Sea almost exclusively uses lead systems and polynyas during winter when ice roads would be constructed. Since the Beaufort lead systems occur many miles north of the LDPI and proposed ice road routes, and no known polynya systems occur near the Liberty prospect, bearded seals should not occur in the Proposed Action Area when ice roads are being constructed or are in use. Due to the lack of bearded seal presence in the Proposed Action Area during winter, ice road construction and use would have negligible levels of effect on bearded seals.

Gravel Mining

As discussed in the Ice Road Construction section, bearded seals are not present in the Proposed Action Area in the winter. Chapter 2 describes the proposed gravel mining activities that would occur in the winter, along with ice road construction. The proposed mine site and the alternate mine sites are located inland and far away from any potential bearded seals or their habitat and so no bearded seals should be affected by mining activities. Consequently, gravel mining would have negligible levels of effect on bearded seals.

LDPI Construction

The LDPI would be constructed during winter and early parts of spring when shorefast ice extends from the Beaufort coastline to a point many miles north of the proposed LDPI site. The extensive and continuous shorefast ice would restrict bearded seals to living in the Beaufort Sea lead systems that occur where the shorefast ice meets the offshore pack ice.

Sheet/Pile/and Pipe-driving

Impact pile-driving and vibratory sheetpile-driving would be used to install proposed LDPI components during the open-water season of construction Year 1 (2015 Liberty EIA). Blackwell, Lawson and Williams (2004) found seals around the Northstar Island were most likely habituated to industrial sounds such as pipe-driving, helicopter use, etc. Figure 4.3.4-11 and the report by SLR (2017) show impact sheet pipe/pile-driving and vibratory sheet driving as the loudest activities scheduled in the Proposed Action. Impact pipe/pile-driving could produce an injury among pinnipeds, with PTS thresholds extending out to 330 m and 240 m for impact sheet pile-driving and impact pipe-driving respectively but only if an individual were to remain within the ensonified zone for an entire work day (SLR 2017).

Some phases of proposed LDPI construction would require the use of helicopters and vessels to move people and materials to and from the proposed LDPI. Figure 4.3.4-8 shows the noise characteristics of aircraft and vessel noises, and compares them to audiograms of ringed and spotted seals. No audiograms have been completed for bearded seals to date; however ringed and spotted seals share enough biological similarities to bearded seals such that they can be used as a proxy for analyzing the noise effects on bearded seals. Aircraft and vessels produce enough noise to create Level B harassment to bearded seals. Large vessel such as barges (≥ 85 m long) produce enough noise as to produce Level A harassment at the lowest frequencies; however such massive vessels cannot enter the shallow waters (19 ft) around the proposed LDPI, and would not be used. Consequently, much of the heavier and larger materials would need to be transported to the proposed LDIP via ice road and possibly with much smaller barges, rather than by large barges. For this reason any vessels used to support construction activities would need to have a draft shallow enough to navigate between the

proposed LDPI and staging areas along the Beaufort Sea coast, most likely Endicott and Prudhoe Bay, Alaska. Such vessels would have to be smaller and quieter, and so would produce lower decibel levels. Any effects from aircraft and vessels would be transient, only lasting for a brief period, and the SELs could not create a PTS or TTS (Table 4.3.4-2), though behavioral thresholds (Level B Harassment) could be surpassed (Figure 4.3.4-10).

Because continuous expanses of shorefast ice, without accessible lead systems, are unusable habitat for bearded seals, proposed LDPI construction activities other than vibratory and impact pipe/pile-driving would have a negligible level of effects on bearded seals. By implementing mitigation strategies described in Appendix C (C-4.2., C-4.3.1.), such as using PSOs to detect, identify, and alter operations in response to seal presence, and by maintaining 1,000 ft (457 m) minimum flight altitudes while avoiding concentrations of pinnipeds the level of effects could be minimized to negligible.

Pipeline Installation

Construction of the proposed pipeline between the LDPI and the Badami pipeline would mostly occur during winter of Year 3 as described in Section 2.1. Bearded seals would be in the Bering Sea, Chukchi Sea, or in the Beaufort lead systems well to the north of the Proposed Action. Since bearded seals are not in the Proposed Action Area during the winter due to the lack of leads or polynyas, pipeline installation would have a negligible level of effects on bearded seals. By incorporating the relevant mitigations described in Appendix C (C-4.3.1.), these effects could be lessened, but not below a negligible level of effects.

Facilities Construction

Facilities construction would occur on the LDPI over several seasons, Figure 2-1 indicates the times when activities would be occurring. Cranes and other heavy equipment would be used during the facilities construction as would power tools and equipment, and generators. Equipment would be supplied via the ice road between Endicott SDI and the proposed LDPI. As noted in the Ice Road Construction section, bearded seals would not be present in the Proposed Action Area during the winter construction. Shallow draft vessels discussed in the proposed LDPI Construction section would be regularly used, the effects of these vessels could be mitigated with the usage of onboard PSOs, as discussed earlier. Though the work site could be noisy at times, this work would occur behind the LDPI seawall which would act as a noise barrier, making the construction noises inaudible to bearded seals. For these reasons the noise production from facility construction would be similar to but less noisy than the noises that occur during proposed LDPI construction. These noises include the use of heavy equipment, plus aircraft and vessel noises, which are found on Figures 4.3.4-7 and 4.3.4-9. Ringed and spotted seals share enough biological similarities to bearded seals that they can be used as a proxy for effects on bearded seals. Moulton et al. (2005) observed ringed seal densities surrounding the Northstar Island during construction and found ringed seal concentrations around the Northstar Island were similar to those found elsewhere in the Beaufort Sea. Therefore, bearded seals are reasoned to also have similar densities around the proposed LDPI during construction, as observed in the Beaufort Sea area. For these reasons facilities construction is expected to have a negligible level of effects on bearded seals. By incorporating the relevant mitigations described in Appendix C (C-4.2., C-4.3.1.), these effects could be lessened, but not below a negligible level of effects.

Drilling Operations

Year-round drilling at the proposed LDPI would occur for up to 10 years post-construction; however, bearded seals would not be present when winter drilling occurred at the LDPI. During the remainder of the year they would be present in the Proposed Action Area. In the 1980's drilling noises were recorded at Sandpiper Island, another artificial island near the LDPI, using a bottom-mounted hydrophone located 0.45 km (0.28 mi) from the Sandpiper Island. Results from that study (Miles et

al., 1986) found the loudest noises occurred between 20 and 50 Hz, and reached their maximum decibel source level of 145 at the 40 Hz frequency (Miles et al., 1986). Table 4.2.4-1 shows bearded seals hear frequencies between 50 Hz and 80 kHz, indicating the frequency band of 20-50 Hz from drilling exceeds the minimum hearing threshold for seals, generally covering around 0.033% of the bandwidth audible to bearded seals ($30 \text{ [drilling bandwidth with higher decibel levels]} \div 79950 \text{ [total audible spectrum]} = 0.00037\% \text{ [percent of audible bandwidth that could be affected]} = \frac{1}{2665} \text{ [proportion of audible bandwidth that could be affected]}$). No notable industry-related acoustic components were observed above 200 Hz on the hydrophone, or two sonobouys deployed through the ice at 3.7 km (2 nmi), and 9.3 km (5 nmi). At a distance greater than 3.7 km (2 mi) lower level tonals at 90, 100, and 120 Hz disappear, and at 9.3 km (5 mi) no manmade drilling noises were detectable (Miles et al., 1986). Consequently, all but the loudest drilling noises, within a 30 Hz spectrum should fade into background noise levels within 2nmi of the LDPI and within 5 nmi all of the drilling noises should have faded to ambient noise levels or lower. Likewise the loudest drilling noise at the Northstar Project decreased to 124 dB re: 1 μ Pa 1 km east of the source (Blackwell, Green and Richardson, 2004), even though the Northstar Project is situated in waters deeper than those at the proposed LDPI.

Since drilling noises fall under the continuous noise category for the NMFS harassment criteria, the threshold for Level B harassment from drilling would be 120 dB, and 190 dB for Level A harassment. Source levels of 145 dB fall well below the Level A harassment threshold; however, for a distance out to a few tens of meters from the proposed LDPI, the Level B harassment threshold of 120 dB could be exceeded. These numbers are supported by similar and subsequent investigations at the Northstar Project (Blackwell, Greene, and Richardson, 2004).

Table 4.2.4-2 shows the modeled PTS and TTS thresholds for phocid seals such as bearded seals to be 235 dB and 229 dB SPL. Considering the maximum source level from drilling at the proposed LDPI should be in the vicinity of 145 dB, as it was at Sandpiper Island which also located in shallow water, there should be no potential for drilling to produce a TTS or PTS among bearded seals.

Because of the lack of effects from winter drilling on bearded seals, the small area of potential adverse effects that could lead to behavioral responses (Level B harassment), and the improbability of any Level A harassments or incidents where drilling elicits a TTS/PTS among bearded seals, the level of effects from drilling would be negligible, mostly consisting of slight behavioral changes around the proposed LDPI. By incorporating the relevant mitigations described in Appendix C (C-4.2., C-4.3.1.), these effects could be lessened, but not below a negligible level of effects.

Production Operations

Blackwell, Greene, and Richardson (2004) noted drilling produced the highest broadband SPL (124 dB re: 1 μ PA) 1 km east of the Northstar Project. They further estimated broadband values from operations alone reached a minimum 3 or 4 km from the artificial island (Northstar), and in all cases the noise from operations was less than drilling noises. Because the noise produced during operations is lower than drilling noises, the effects would be similar to those of drilling, only to a lesser degree. Moulton et al. (2005) monitored seal densities and Northstar Island construction noise, and found the concentrations of seals around the Northstar Island were mostly similar to what was found in areas farther away from the Northstar Island in 1997-2002. BOEM assumes that similarly, concentrations of bearded seals would be similar in the proposed LDPI during operations as are found in the Beaufort Sea. For this reason drilling operations would have a negligible level of effects on bearded seals. By incorporating the relevant mitigations described in Appendix C (C-4.2., C-4.3.1.), these effects could be lessened, but not below a negligible level of effects.

Decommissioning

The noises and other disturbances produced during decommissioning would involve the use of vessels and heavy equipment, making them similar to the noises produced during construction of the proposed LDPI. However, decommissioning could likely be accomplished within a smaller time period than construction, making the effects more transient. Furthermore, by the time decommissioning is initiated, many seals in the area would have likely habituated to the noise and activity associated with the proposed LDPI. For these reasons decommissioning should have a negligible level of effects on bearded seals.

Oil Spills

Contact with crude oil could injure bearded seals (NRC, 2003), and the more volatile compounds in an oil slick, particularly aromatic volatiles, usually have the greatest toxicity. In situ, cold-water measurements (Payne et al., 1984) have demonstrated that individual compounds in a slick decrease significantly in concentration in hours to tens of days. Many studies have been conducted on ringed seals to analyze the impacts of hydrocarbons on fitness and mortality; BOEM has reviewed these studies and, as discussed earlier, uses ringed seals as a biological proxy for bearded seals due to their numerous biological similarities. Investigations into the effects of crude oil ingestion and exposure on ringed seals (Geraci and Smith, 1976a) indicate the risk of seals accidentally ingesting large amounts of oil by way of contaminated food items is low. Moreover, only small, transient effects were identified during necropsies of ringed seals fed potent fractions of carbon tetrachloride. Immersion studies by Smith and Geraci (1976) found ringed seals can develop mild liver damage, kidney lesions, and eye damage from immersion in crude oil, etc. which was also confirmed by Frost and Lowry (1994). Furthermore, the eye damage was severe, suggesting permanent eye damage might occur with prolonged exposure to crude oil. Unlike the animals in the immersion study, seals in the open water would have ice as a resting/escape platform as well as water depth and distance for escape routes from an oil spill, which they should be able to detect and avoid (St.Aubin, 1990).

Though the study conducted by Geraci and Smith (1976b) resulted in 100% mortality in captive ringed seals, the self-correction of many of the effects from crude oil contact have been documented among ice seals, particularly by purging their bodies of hydrocarbons through renal and biliary pathways, providing the duration of exposure isn't too great (Engelhardt, Geraci, and Smith, 1977; Engelhardt, 1982, 1983, 1985; Smith and Geraci, 1975; Geraci and Smith, 1976a, 1976 b; St. Aubin, 1990). However, Spraker et al. (1994) observed lesions in the thalamus of harbor seal brains after they were oiled, possibly explaining motor and behavioral anomalies (Engelhardt 1983). Lowry, Frost, and Pitcher (1994) also observed reproductive complications in harbor seals having been exposed to oil during the *Exxon Valdez* Oil Spill.

Overall, the severity of injury correlates with the duration of exposure and quantities of crude oil contacted. Older seals and those in weaker physical condition show greater sensitivity to immersion in crude oil.

Small Spills

Small spills in the winter would be unlikely to affect bearded seals due to their absence from the shorefast ice areas surrounding the proposed LDPI. A small spill during the remainder of the year could have some adverse effects on bearded seals; however, the relatively small size of the spill should prevent any prolonged exposures from occurring, while limiting the extent of the areas that could be contacted, and limiting the amount of hydrocarbons that an individual seal could contact. Furthermore, the size of a small spill would also limit the potential extent of contamination to the benthic organisms bearded seals mostly prey upon. For these reasons a small spill should have a negligible level of effects on Beaufort Sea bearded seals and the Beringian DPS of bearded seals.

Large Spills

In the event of a large crude oil spill, or a gas release, some bearded seals could be affected. Due to sea floor topography, bearded seals forage between the continental shelf break and coastal areas. Ice formation and gouging in shallower waters along the Beaufort Sea coastline prevents the presence of benthic invertebrates in many areas. For this reason bearded seals mainly use deeper waters where they can feed on benthos at depths where ice normally cannot reach the bottom. There are no documented concentration areas for bearded seals have ever been identified in the Beaufort Sea, so no ERAs have been developed for them. A proportionately small fraction of the bearded seal population is believed to overwinter in the Beaufort Sea lead systems where they mostly haul out for resting, molting, and pupping on ice floes and pack ice, many miles to the north of the proposed LDPI.

Large spills contacting lead or polynya systems could result in some bearded seal mortalities, especially if young seal pups are present (St. Aubin, 1990). Such an occurrence would produce minor to moderate effects among bearded seals trapped in an oiled lead system, though they could haul out on ice, and only patches of the lead system would be oiled. Since bearded seals are less common in the Beaufort Sea than the Chukchi Sea, the potential for contact within lead systems is less. Furthermore, large spills contacting leads and polynyas would also require time to travel from the LA or PL to a lead or polynya, weathering and dispersing along the way, possibly lowering the volume of oil that would eventually contact leads. With the passage of time, much of the oil could gel or emulsify in low temperatures, making spill patches easier to observe and avoid by bearded seals if gelled, or it could become frozen in ice if emulsified.

ERAs (46, 48, and 62) have been identified as particularly important habitat to bearded seals for the OSRA spill analysis. Contact probabilities that have a probability of contact value of less than 5% have a greater than 95% of not being contacted, and are not reasonably foreseeable events and will not be analyzed. The Annual Conditional Probabilities found in Appendix A, Tables A.2-1 thru A.2-6 do not show ERA's 46, 48, or 62 being contacted by a large spill from the proposed LDPI (LI), or the proposed pipeline (PL). Likewise no contacts >5% are reflected in Tables A.2-19 thru A.2-24, and A.2-34 thru A.2-42 for the Summer or Winter Conditional Probabilities. No Land Segments (LS) or Grouped Land Segments (GLS) were identified as important to bearded seals.

The lack of contact with ERAs important to bearded seals, location of the proposed LDPI in shallow water, presence of ubiquitous shorefast ice surrounding the proposed LDPI, relatively small presence of bearded seals in the Beaufort Sea compared to the Chukchi Sea, and the assumption that bearded seals can identify and avoid spilled oil indicates large spills would have a moderate level of effects on bearded seals, due to the loss of a few individuals during the open-water season or when large amounts of broken ice is present. During the winter months, a large spill from the proposed LDPI should have negligible levels of effect on bearded seals, since the spilled materials would remain on top of a solid sheet of sea ice. A large spill from PL would also be unlikely to affect bearded seals considering the limited ability to spread into any of the Beaufort Lead Systems (ERA's 30-37) where the probability of a winter spill contacting the leads would be $\leq 1\%$ and not foreseeable.

For these reasons a large spill from either the proposed LDPI (LI) (5,100 bbl) or pipeline (PL) (1,700 or 5,000 bbl) could have negligible effects on bearded seals during winter when the proposed LDPI and pipeline are surrounded by shorefast ice. During periods of open water or broken ice, potential mortalities of a few bearded seals could occur, and the assumed large spill sizes would most likely not result in mortalities. For this reason a large spill would likely have a minor level of effect on bearded seals; however, a prompt oil spill response and successful spill cleanup could lessen those effects to a negligible level of effects.

Oil Spill Response

In the event of a large oil spill, the presence of humans, boats, and aircraft operating in the area involved in cleanup activities is expected to cause displacement of some bearded seals from the oiled areas and temporarily add the stressors of vessel traffic, and human activity to affected bearded seals. These effects would occur during cleanup operations (1 or perhaps 2 seasons) but is not expected to significantly affect individual bearded seals or the Beringian DPS of bearded seals. Because of the temporary harassment of bearded seals from areas that might be contacted with oil, the level of effects from oil spill response would be minor.

4.3.4.3.2. Alternative 2 (No Action)

The No Action alternative would not affect bearded seals. The Beringian bearded seal DPS would continue with current population trends.

4.3.4.3.3. Alternative 3 (Alternate Locations for the proposed LDPI)

The effects and levels of effect from Alternative 3 would be the same as was described for the Proposed Action.

4.3.4.3.4. Alternative 4 (Alternate Processing Locations)

The effects and levels of effect from Alternative 4 would be the same as was described for the Proposed Action.

4.3.4.3.5. Alternative 5 (Alternate Gravel Sources)

The effects and levels of effect from Alternative 5 would be the same as was described for the Proposed Action.

Summary

The overall effects of the Proposed Action on bearded seals would be negligible. Only a large spill during the open-water season could potentially cause harm to some bearded seals; however the effects of a large, open-water spill on bearded seals would be limited by the assumed spill size, trajectory, constituents, weathering, residence time in the environment, and by the spill response. Under no circumstances could population-level effects in the bearded seal stock result from any individual, or from the combined activities in the Proposed Action, and most likely no mortalities would occur from a large oil or diesel spill. For these reasons the Proposed Action should have a negligible level of overall effects on bearded seals.

The effects of climate change on bearded seals under the Proposed Action, for the lifespan of the proposed action, would not differ from what was described in Section 3.2.4.1. Likewise the expected changes to the environment from climate change over the next 30 years should not substantially alter the effects of the Proposed Action or their impacts on bearded seals.

4.3.4.4. Ringed Seal

4.3.4.4.1. The Proposed Action

Ice Road Construction

Ice road construction for the Northstar Project, a similar gravel production island in the Beaufort Sea, affected the behavior of a few seals and their use of lairs within 0.64 kilometers (0.4 mi) of the ice roads but had little effect on ringed seal distribution and abundance (Richardson and Williams, 1999, 2000, and 2001; Williams et al., 2006). Consequently, a small number of adult ringed seals and pups would likely be affected or displaced by ice roads where the roads pass over shorefast ice between the

proposed Endicott SDI support location, the proposed mine site and the LDPI (Maps 5-1 and 5-2); however, those sections of ice road crossing grounded shorefast ice would not affect any ringed seals.

For those sections of ice road over fast ice areas supporting ringed seals, the number of seals displaced from their lairs would be low, probably 1-2 seals per kilometer of ice road, and only for sections of ice road on floating fast ice (<5 miles from the Kadleroshilik River, and <7.5 miles from the Endicott SDI; Section 2.1.1) in years 1 thru 5.

This displacement would not affect the ringed seal population or greatly affect their distribution in Foggy Island Bay, though some lairs and denning sites could be destroyed early in the season during ice road construction, if ice roads traversed lair habitat. The effects would occur periodically over the 25-year life of the Proposed Action, but only when ice roads are constructed and used.

Consequently, the use of ice roads would have a minor level of effect on ringed seals due to elicitation of avoidance responses by ringed seals, and the potential for the destruction of subnival lairs as ice roads are built. If trained dogs, controlled with shock collars are used to locate, and help avoid, ringed seal dens, the level of effects from the Proposed Action would be reduced to negligible.

Mine Site Development

The effects of mine site development on ringed seals would be consistent with what was described for bearded seals.

LDPI Construction

Ringed seals use the shorefast ice areas surrounding the proposed LDPI. For this reason, they could be affected, particularly by construction noise, and gravel placement. The noises produced from proposed LDPI construction are similar to what was depicted in Figure 4.3.4-9.

Sheet/Pile/and Pipe-driving

Of all the noises associated with proposed LDPI construction, vibratory sheet piling was considered the loudest at over 140 dB at source; however none of the noises are sufficient to produce any injuries to ringed seals, and Blackwell, Lawson, and Williams (2004) found that some ringed seals approached to within 46 m from pipe-driving operations during the construction of the Northstar Island. Moreover, none of the seals observed during construction of the Northstar Island exhibited strong reactions to activities other than helicopter operations which elicited escape reactions in 92% of seals observed concurrently with helicopter activity, similar reactions by ringed seals would be expected in the Proposed Action Area during construction activities.

For these reasons, expected MMPA Level B harassments to a few ringed seals would occur in the vicinity of the proposed LDPI, though no MMPA Level A harassments should occur. The high degree of habituation that Blackwell, Lawson, and Williams (2004) observed would probably apply to the proposed LDPI site considering the proximity to Endicott and the history of other manmade islands and anthropogenic activity in the area.

Creation of the proposed LDPI would have the greatest effect on ringed seals, since it would change several acres of underwater habitat that ringed seals have used; however, the proposed LDPI itself could provide haulout opportunities for seals at times when sea ice is clear of the bay, such as in late summer. Likewise, as described for the proposed LDPI construction analysis for bearded seals, vessels and helicopters could be used to transport personnel and materials to and from the proposed LDPI. The level of effects from either could be minor for ringed seals, and so proposed LDPI construction would have a minor level of effects on ringed seals. By incorporating the relevant mitigations described in Appendix C (C-4.2., C-4.3.1.), these effects could be lessened, but not below a negligible level of effects. However the effects from habitat changes would remain minor, keeping the overall level of effects minor.

Pipeline Installation

Ringed seals could occur along the pipeline route between the proposed LDPI and the pipeline tie-in with the Badami pipelines. The pipeline would be trenched into the sea floor, mostly during winter which would require the use of a Ditch Witch to cut through the shorefast ice and a dredge or excavator to trench into the sea floor. The Ditch Witch produces a noise up to 122 dB at frequencies of 5 Hz–3.15 kHz (Table 4.3.4-5 and Figure 4.3.4-9), which could not cause physical injury to ringed seals. The 122 dB sound level barely exceeds the 120 dB limit for Level B harassment (behavioral) from continuous noises and never approaches the Level A harassment threshold. About 1.49% of the noise produced by a Ditch Witch could overlap the spectrum of noises audible to seals; however, the decibel levels produced by an operating Ditch Witch are not constant, and the 122 dB value represents the highest recorded noise in any frequency band emanating for such equipment. Consequently, only a small band of noise, much smaller than the 1.49% would cross the 120 dB Level B harassment threshold.

The proposed LDPI would begin in about 19 ft of water, and end at the coast, progressing through waters that become shallower closer to the coast. Once waters reach 9–10 ft in depth, the open-water space is too narrow to preclude ringed seal use; at shallower sea depths, once landfast ice occurs, this area is useless to ringed seals which require open water for movement and foraging. Consequently, only the water depths between the proposed LDPI and the 10 ft bathymetric line provide habitat where ringed seals could potentially be affected, or around the first 15,000 ft of the proposed pipeline (2015 Liberty EIA, Figure 4.1.6-4). The remaining 15,000 ft of pipeline would be laid through ice frozen into the seabed. If a high-end density of 1 ringed seal per km² is assumed (as discussed in Chapter 3, Ringed Seals) for winter, no more than 5-10 ringed seals could or should be affected by trenching in a subsea pipeline in any winter. Furthermore, the open water left behind the trenching activities might provide beneficial places for ringed seals to bask, forage, or create new dens or breathing holes.

For these reasons the installation of the proposed pipeline would have a minor level of effects on ringed seals; however, moving heavy equipment across the fast ice could crush or collapse some ringed seal dens, trapping or crushing seals in their dens, while destroying the dens. Such effects raise the level of effects to minor level of effects to ringed seals, after considering the population size estimates. The moderate level of effects could be reduced to negligible if trained dogs, under shock-collar control to avoid disturbing seals, are used to identify ringed seal dens, and if the operator avoids those dens (Appendix C: C-4.1.1.(2), C-4.1.1.(3)).

Facilities Construction

The effects of proposed LDPI construction on ringed seals would be consistent with what was described for bearded seals.

Drilling Operations

The effects of drilling on ringed seals would be similar to what was described for bearded seals with the exception that ringed seals are year-round residents of Foggy Island Bay and the area around the proposed LDPI. For this reason ringed seals could be affected at any time during operations; however, there is no potential for Level A harassment, or inducing a PTS or TTS among ringed seals. Some Level B harassment exists; however during winter many ringed seals would be insulated in their dens at times such that the snow pack and ice would dampen the noise levels inside the dens (Blackwell, Lawson, and Williams, 2004). For these reasons and those contained in the noise analysis previously explained for bearded seals, drilling operations should have a negligible level of effects on ringed seals.

Production Operations

The effects of production operations on ringed seals would be consistent with what was described for bearded seals.

Decommissioning

The effects of Decommissioning on ringed seals would be consistent with what was described for bearded seals.

Oil Spills

The effects of oil spills on ringed seals would be similar to what was described for bearded seals. Ringed seals are more common in the Beaufort Sea than are bearded seals, especially in winter. Though the effects to individuals would be consistent with those described for bearded seals, ringed seals are more likely to be contacted by spilled oil due to their greater numbers, and year-round presence in the Beaufort Sea, particularly in Foggy Island Bay.

Small Spills

A small spill from the proposed LDPI should have negligible levels of effect on ringed seals during winter, since the spill would spread out onto the solid sheet of sea ice and could be cleaned up. A small spill during the open-water season or into broken ice could be more problematic, though a small spill would have a great deal of difficulty escaping beyond the interior of the proposed LDPI, considering the proposed LDPI's design features such as berms and the seawall. The most likely venue for a small spill to contact ringed seals would be through a pipeline rupture, which could create a loss of pressure inside of the pipeline, effectively stopping the spill. Only a pipeline rupture along the first 2.84 mi (4.57 km) has the potential to contact ringed seals, since the remainder of the pipeline would lie under solid ice. Because of the small size (<1,000 bbl) of small spills, the ability of ringed seals to detect and avoid spills, and the limited set of conditions where a spill could actually contact ringed seals, and the limited duration of contact that would occur with a small spill, the level of effects from a small spill to ringed seals would be negligible.

Large Spills

In the unlikely event of a large crude oil spill, or a gas release, some ringed seals could be affected. No documented concentration areas for ringed seals have ever been identified in the Beaufort Sea, so no ERAs have been developed for them. Though most ringed seals are believed to vacate the Beaufort Sea during winter, to overwinter in the Chukchi and Bering Seas, some continue to use the Beaufort Sea, particularly areas of extensive shorefast ice where they can create breathing holes, and dens, while feeding under the ice.

Large winter spills from LI would likely spread across a solid sheet of sea ice and so would not likely affect many ringed seals, even if some oil contacted water through breathing holes or dens. Such a spill could be cleaned up and removed from the area efficiently; however, a winter spill from PL could contact more ringed seals and eventually coat the underside of the sea ice over a wide area, flowing upwards through breathing holes, fractures, and capillaries to permeate the ice pack.

Large spills contacting lead or polynya systems could result in some ringed seal mortalities, especially if young seal pups are present (St. Aubin, 1990). Such an occurrence would produce minor to moderate effects among ringed seals living around an oiled lead system, though they could haul out on ice, and only patches of the lead system would likely be contacted. Ringed seals prefer to overwinter in shorefast ice, particularly around lead systems and polynyas, so those areas may support higher concentrations of ringed seals than areas of solid, ubiquitous shorefast ice.

Large spills contacting leads (ERAs 30-37) and polynyas would require time to travel from PL to a lead or polynya, weathering and dispersing along the way, or getting incorporated into the sea ice, all

of which would probably lower the potential volume of oil that eventually contact leads. With the passage of time, much of the oil could gel or emulsify in low temperatures, making spill patches easier to observe and avoid by ringed seals, or became frozen in ice.

No ERAs were specifically created for ringed seals due to their ubiquitous presence in the Beaufort Sea and because no peer-reviewed scientific literature exists indicating their concentrations are consistently greater in some locales than others. The Beaufort Sea Spring Lead System (ERAs 20 thru 37) could provide higher quality ringed seal habitat in the OSRA. Contact probabilities are all less than <5%, and so have a >95% probability of not being contacted, and so are not reasonably foreseeable events and will not be discussed further. Consequently, the effects of a large spill from LI or PL on ringed seals during the open-water season or in broken ice would likely be moderate considering the likelihood of some ringed seal mortalities. In contrast a winter spill from LI (5,100 bbl) would be unlikely to result in any ringed seal mortalities, though a winter spill from PL (1,700 or 5,000 bbl) would likely produce a few mortalities. The loss of hydrostatic pressure from a pipeline rupture would limit the volume of a potential spill, which in turn would limit the dispersion, duration, and extent of the spilled materials. For these reasons, the overall level of effects on individual ringed seals from a large oil spill would be moderate; however the level of effect on the population would remain negligible. A prompt and efficient oil spill response would reduce those levels of effects to negligible or minor if the spill response were to capture the majority of the spilled materials.

Oil Spill Response

The effects of oil spill response would be the same as was described for bearded seals.

Summary

The overall effects of the Proposed Action on ringed seals would be negligible. Only a large, under-ice spill from a pipeline (1,700 or 5,000 bbl) could potentially cause harm to ringed seals, but would be limited by the assumed spill size, trajectory, constituents, weathering, residence time in the environment, and by the spill response. Under no circumstances could population-level effects in the ringed seal stock result from any mortalities associated with a pipeline rupture/leak, or from the combined activities or the Proposed Action, and most likely few if any mortalities would occur from a large oil or diesel spill from the LDPI (5,100 bbl). For these reasons the Proposed Action should have a negligible level of overall effects on the ringed seal population, and a moderate effect on a few individual seals.

The effects of climate change on ringed seals under the Proposed Action, for the lifespan of the proposed action, would not differ from what was described in Section 3.2.4.1. Likewise the expected changes to the environment from climate change over the next 30 years should not substantially alter the effects of the Proposed Action or their impacts on ringed seals.

4.3.4.4.2. Alternative 2 – No Action

The No Action alternative would not affect ringed seals. The Western Arctic ringed seal stock would continue with current population trends.

4.3.4.4.3. Alternative 3 (Alternate Locations for proposed LDPI)

The effects and levels of effect from Alternative 3 would be the same as was described for the Proposed Action.

4.3.4.4.4. Alternative 4 (Onshore Processing Locations)

The effects and levels of effect from Alternative 4 would be the same as was described for the Proposed Action.

4.3.4.4.5. Alternative 5 (Alternate Gravel Sources)

The effects and levels of effect from Alternative 5 would be the same as was described for the Proposed Action.

4.3.4.5. Spotted Seal

4.3.4.5.1. The Proposed Action

Ice Road Construction

Spotted seals do not use the Beaufort Sea when ice road construction would be occurring, or when ice roads would be in use. For this reason the construction of ice roads would have negligible levels of effect on spotted seals.

LDPI Construction

Spotted seals do not use the Beaufort Sea when much of the LDPI construction activities would occur. Some activity would occur during summer after the island is built, however those activities would occur on the island and behind the perimeter berm of the island, and mostly would not affect spotted seals. For this reason the construction of the LDPI should have negligible effects on spotted seals. After construction the LDPI presence would likely have a positive effect on spotted seals by providing a quality haulout location for seals to rest between bouts of foraging.

Sheet/Pile/and Pipe-driving

Pipeline Installation

Spotted seals occur throughout Foggy Island Bay during summer and haul out on gravel bars in the Sagavanirktok River. The pipeline would be trenched into the sea floor, mostly during winter which would require the use of a Ditch Witch to cut through the shorefast ice and some sort of dredge or excavator to trench into the sea floor. The Ditch Witch produces a noise up to 122 dB at frequencies of 5 Hz–3.15 kHz (Table 4.3.4-5 and Figure 4.3.4-2), which could not cause physical injury to spotted seals. The 122 dB sound level exceeds the 120 dB limit for Level B harassment from continuous noises but never approaches the Level A harassment threshold. About 1.49% of the noise produced by a Ditch Witch could overlap the spectrum of audible noises for seals; however, the decibel levels produced by an operating Ditch Witch are not constant, and the 122 dB value represents the highest recorded noise in any frequency band emanating for such equipment. Consequently only a very tiny band of noise, much smaller than the 1.49% would cross the 120 dB Level B harassment threshold. At any rate spotted seals do not use the Beaufort Sea during winter so should not be present when the LDPI pipeline is being constructed.

For these reasons the installation of the proposed pipeline would have negligible levels of effect on spotted seals.

Facilities Construction

Facilities construction should have limited effects on spotted seals which only use the Beaufort Sea during summer. During winter construction activities would have negligible levels of effect on spotted seals, and during summer spotted seals may observe some activities, but for brief periods of time with interludes between construction events. For these reasons facility construction should have negligible effects on spotted seals.

Drilling Operations

The effects of drilling on spotted seals would be similar to what was described for bearded seals; however, such effects would only occur during the summer when spotted seals are present in the Beaufort Sea, and there is no potential for Level A harassment, inducing a PTS or TTS among ringed

seals. Some Level B harassment exists; however considering the physiological similarities between spotted seals and harbor seals, spotted seals may habituate to non-injurious noises such as drilling from the proposed LDPI. Based on this available information drilling operations should have a negligible level of effects on spotted seals.

Production Operations

Production operations should have negligible levels of effect on spotted seals.

Decommissioning

Oil Spills

The effects of oil spills on spotted seals would be similar to what was described for ringed and bearded seals in open-water conditions. Spotted seals are believed to be less common than bearded or ringed seals across the expanse of the Beaufort Sea; however, 2014 marine mammal monitoring (BPXA, 2014) observed more spotted seals in Foggy Island Bay near the proposed LDPI, than all other marine mammal species combined. Though the effects to individuals would be consistent with those described for ringed and bearded seals, spotted seals may avoid some areas of spilled oil by venturing up freshwater rivers, or hauling out of the water onto land.

Small Spills

A small spill from the proposed LDPI should have negligible levels of effect on spotted seals during winter, since they do not use the Beaufort Sea during winter. A small spill during the open-water season or into broken ice could be more problematic, though a small spill would have a great deal of difficulty escaping beyond the interior of the proposed LDPI, considering the perimeter berm surrounding the proposed LDPI. The most likely venue for a small spill to contact ringed seals would be through a pipeline rupture which could create a loss of pressure inside of the pipeline, effectively stopping the flow of oil through the pipeline and limiting the spill volume. Because of the small spill size (<1,000 bbl), the ability of phocid seals to detect and avoid spills, and the limited set of conditions where a spill could actually contact spotted seals, and the limited duration of contact that associated with a small spill, the level of effects from a small spill to spotted seals would be negligible.

Large Spills

In the unlikely event of a large crude oil spill, or a gas release, some spotted seals could be affected, but only during summer when they are present in the Beaufort Sea. ERAs 1 (Kasegaluk Lagoon Area), 46 (Wrangel Island 12 nmi buffer 2), 48 (Chukchi Lead System), 62 (Herald Shoal Polyna 2), 64 (Peard Bay Area/Franklin Spit Area), 65 (Smith Bay: Spotted Seal Haulout), 68 (Harrison Bay), and 69 (Harrison Bay/Colville Delta have been identified as important resource areas for spotted seals in the Beaufort and Chukchi Seas. GLSs 148 (Kolyuchin Bay), 169 (Smith Bay Spotted Seal Haulout, and 173 (Harrison Bay Spotted Seal Haulout were also identified as important to spotted seals).

Between 5% and 6% of modeled spill trajectories contacted ERA 68 from a LI summer spill between 30 and 360 days, and there was a 5% contact probability of a LI spill contacting ERA 69 after 90 days. No ERAs had contact probabilities $\geq 5\%$ by winter spills, nor by annual spills. Likewise no GLSs had contact probabilities $\geq 5\%$.

Oil Spill Response

The effects of oil spill response would be the same as was described for bearded seals.

Summary

The overall effects of the Proposed Action on spotted seals would be negligible. Only a large spill could potentially cause harm to spotted seals, but those effects would be limited by the assumed spill

size, trajectory, constituents, weathering, residence time in the environment, and by the spill response. Under no circumstances could population-level effects in the spotted seal stock result from mortalities associated with a large spill, or from the combined activities or the Proposed Action. For these reasons the Proposed Action should have a negligible level of overall effects on spotted seals.

The effects of climate change on spotted seals under the Proposed Action, for the lifespan of the proposed action, would not differ from what was described in Section 3.2.4.1. Likewise the expected changes to the environment from climate change over the next 30 years should not substantially alter the effects of the Proposed Action or their impacts on spotted seals.

4.3.4.5.2. Alternative 2 – No Action

The No Action alternative would not affect spotted seals. The Alaska spotted seal stock would continue with current population trends.

4.3.4.5.3. Alternative 3 (Alternate Locations for proposed LDPI)

The effects and levels of effect from Alternative 3 would be the same as was described for the Proposed Action.

4.3.4.5.4. Alternative 4 (Onshore Processing Locations)

The effects and levels of effect from Alternative 4 would be the same as was described for the Proposed Action.

4.3.4.5.5. Alternative 5 (Alternate Gravel Sources)

The effects and levels of effect from Alternative 5 would be the same as was described for the Proposed Action.

4.3.4.6. Polar Bears

4.3.4.6.1. The Proposed Action

Ice Road Construction and Use

Polar bears occur at low densities on the mainland coast, barrier islands, and sea ice of the Proposed Action Area during winter and spring months when ice road activities would occur. Pregnant female polar bears may occupy dens in the area from November through April, although some bears may not enter dens until late November or early December (Amstrup and Gardner, 1994). Both suitable maternal den habitat and historical den sites are present in the Proposed Action Area (Figure 3.2.4-15).

Disturbance and Displacement.

Ice road construction and use produces noise, vehicle traffic, and human presence that can disturb or displace polar bears from the immediate area (USDOJ, USFWS, 2011). Alternately, non-denning bears can be drawn to ice road activities due to presence of attractants such as food waste, or out of curiosity (see further discussion in Human-Bear Interactions, below) (USDOJ, USFWS, 2011; USDOJ, USFWS, 2015cjp). The type and extent of disturbance and displacement impacts can vary depending on the polar bear's life history status (e.g., pregnant/post-partum vs. not pregnant). For this reason, disturbance and displacement impacts to bears in maternity dens are discussed separately from impacts to non-denning bears.

Denning Polar Bears. Polar bears generally are not very sensitive to noise or other anthropogenic disturbances (Amstrup, 1993; Richardson et al., 1995); however, females and offspring in maternity dens may be more sensitive to noise and vehicle presence than non-denning bears (Amstrup and Gardner, 1994). Behavioral responses of denning females and of family groups are variable; denning

females may be tolerant of nearby ground traffic in winter and spring (Amstrup, 1993; USDOJ, USFWS, 2011; USDOJ, 2012). In addition, snow cover is an effective insulator, preventing the attenuation of noise into dens (MacGillivray et al., 2003).

The commencement date of ice road construction is dependent upon ice conditions (e.g., thickness), but would likely begin in mid to late December, after most bears have entered maternal dens and shortly before they would give birth (Harington, 1968; Ramsay and Dunbrack, 1986). Disturbance from ice road construction and use could cause den abandonment for females in the immediate area. Pregnant bears could be displaced from dens in the early part of the denning season (early winter), and to a lesser extent pregnant individuals or those with newborn cubs could be displaced later in the season (Amstrup, 1993; Derocher and Stirling, 1992; Linnell et al., 2000; Ramsay and Dunbrack, 1986). Pregnant females or post-partum female that abandon dens in mid-winter are at increased risk of mortality from starvation and exposure because female bears in maternal dens fast until emergence in the spring and pregnancy and lactation increase the energetic cost of survival during what is already a period of energy deficit. Early emergence of cubs, even in spring, can have adverse consequences because cub survival is correlated with their weight at the time they exit the maternity den (Blix and Lentfer, 1979; Derocher and Stirling 1992).

Ice roads for the Proposed Action would continue to be used and maintained through mid-April each year (possibly as late as May for offshore sections). Female polar bears and cubs exit dens in March through April (Amstrup and Gardner, 1994; Bishop and Streever, 2016).

After emerging, family units can spend several days in the vicinity of the den before permanently abandoning it (USGS data cited in USDOJ, USFWS, 2006). During this time females and cubs may be particularly susceptible to disturbance (USDOJ, USFWS, 2012).

The potential impacts of disturbance and displacement to females and cubs could be greater than for non-denning bears. The energetic consequences of moving away from disturbance may be more pronounced in energy-depleted mothers and energy-limited offspring. Disturbance and displacement can also result in the separation of family units (USDOJ, USFWS, 2011). Both of these impacts could in turn affect the health and survival of females and offspring. However, with the exception of cub mortality from separation, reactions of family units to anthropogenic activities are generally brief and temporary, and not of long-term consequence to individuals (USDOJ, USFWS, 2011).

Non-Denning Polar Bears. Polar bears that are not occupying maternity dens are active throughout the winter and may occur in the Proposed Action Area as they use the coastline and sea ice for foraging, resting, and traveling. Non-denning bears appear to be less sensitive to industrial noise and activities than denning females (Richardson et al., 1995; Smith et al., 2007).

If a non-denning bear was disturbed by ice road construction and use, whether through auditory or visual stimuli, the animal could react by moving away from the area of activity. Bears could be deflected away from transit corridors and access to important habitat (e.g., foraging areas) or, alternately, towards areas of Proposed Action activity (see further discussion in Habitat Loss and Alteration and Human-Bear Interactions, below). However, this disturbance and displacement would be temporary and localized (USDOJ, USFWS, 2011; USDOJ, USFWS, 2012).

Habitat Loss and Alteration.

Ice road construction and use can seasonally alter limited areas of potential polar bear critical habitat both on-shore and offshore; however, these impacts are temporary and affect only a small portion of habitat available to polar bears (USDOJ, USFWS, 2012). Under the Proposed Action, ice road footprints would temporarily alter terrestrial and barrier island denning, and sea ice designated critical habitat; the acreage made unavailable would vary among years but would be greatest during the first two years of the Proposed Action.

Polar bears may alter their travel route to avoid contact with human activities or because intentional hazing deflects them away from the area (USDOJ, USFWS, 2011; USDOJ, USFWS, 2012); however, such effects would be localized and would not prevent bears from accessing areas altogether. Furthermore, polar bears are commonly documented crossing roads and navigating the oil fields at Prudhoe Bay and other developed portions of the onshore and nearshore Beaufort Sea coastline without apparent difficulty; therefore oil and gas infrastructure is not considered to act as a significant barrier to polar bear movements (USDOJ, USFWS, 2011; USDOJ, USFWS, 2012).

Ice roads are likely to affect females once they exit maternity dens with cubs-of-the-year because they can produce a disturbance and displacement response caused by auditory or visual stimulus. After den emergence, females will move to sea ice foraging habitat to replenish depleted energy stores. Ice road presence and traffic could possibly lead to early den abandonment by the mother, putting the cubs at risk because they may not be able to survive the sea ice environment away from the “protective” environment of the den site.

Ice road construction and use could affect polar bears indirectly through prey impacts. Ice roads may displace ringed seals from pupping lairs or haulouts, and seals could abandon breathing holes near ice roads. However, disturbances would likely only temporarily affect a few ice seals and affect only a small proportion of potential foraging habitat; and thus would not impact bears’ overall ability to successfully obtain and consume prey (USDOJ, USFWS, 2011).

Human-Bear Interactions.

Anytime human activities overlap with habitat used by polar bears there is potential for human-polar bear interactions. An increase in human-bear interactions can occur if bears are deflected away from coastal travel corridors and towards developed areas. The presence of attractants (e.g., food waste) associated with construction activities and traffic can also increase human-bear interactions (Streever and Bishop, 2013; Streever and Bishop, 2014; USDOJ, USFWS, 2015cjp). In addition, ice roads can increase ease of access to areas where attractants and human activity are present (USDOJ, USFWS, 2011).

Most polar bears observed by the oil and gas industry in the U.S. Beaufort Sea exhibit no discernible change in behavior in response to anthropogenic activities (USDOJ, USFWS, 2011). Polar bears are curious and while some individuals may avoid or retreat from human activities, others may approach to investigate. Bears that enter areas of industry activity may be actively deterred (or hazed/harassment) so that they vacate the site. Hazed bears could experience temporary disturbance and stress from some deterrence activities (e.g., from acoustical devices, moving vehicles, spotlights) and may walk, run or swim away. For healthy bears, any stress they experience from this activity would likely be short term; bears that have walked or swam long distances may experience longer periods of stress and may have to rest elsewhere prior to resuming normal activities such as feeding. Bears that are deterred using more aggressive methods (e.g., projectiles such as bean bags and rubber bullets), would likely experience stress and short-term pain (USDOJ, USFWS, 2011).

Other Sources of Injury or Mortality.

Physical injury or mortality of polar bears as a consequence of ice road activities is extremely unlikely due to the alert and highly mobile nature of the species.

Vehicle-Bear Collisions. Traffic on ice roads poses a collision risk to polar bears; however, no such incidental collisions of polar bears and terrestrial vehicles have been documented on the North Slope (USDOJ, USFWS, 2012). In general, bears that have not been previously food-conditioned to human presence would be expected to avoid close interactions with moving vehicles given their mobility and the noise of the vehicles. Additionally, given that the majority of ice road traffic supporting the proposed action is comprised of slow-moving construction vehicles, bears transiting ice roads would have sufficient time to move out of the way of any oncoming traffic (Hilcorp, 2015, Table 5-6).

Contaminant Exposure. Ice road-related operations would require the use of substances that can be both attractive and toxic to wildlife. Polar bears could be exposed to these toxins if they are not properly stored or if small spills occur and are not fully contained and cleaned-up. No known illnesses or mortalities of polar bears have been definitively linked to chemical exposure from North Slope oil and gas activities; however, Amstrup et al. (1989) investigated the remains of a polar bear that appeared to have ingested ethylene glycol (antifreeze) and rhodamine B (two compounds used to mark roads and runways during winter months) shortly before its death. A similar incident involving an adult female and yearling was investigated by USFWS in 2012 (Streever and Bishop, 2013). Because standard chemical storage and disposal procedures are typically implemented during North Slope oil and gas operations, it is unlikely that a polar bear would come into contact with harmful substances. Small refined oil spills could occur during ice road construction and use. Potential impacts to polar bears from small spills are addressed in Oil Spills-Small.

Conclusion

Potential for impacts to polar bears and polar bear critical habitat from most ice road construction and use during the Proposed Action would be seasonal and would not persist longer than the first two years (the period when multiple roads would be needed to support proposed LDPI construction and pipeline installation). Long-term seasonal disturbance, displacement, habitat loss alteration, and increased potential for human-bear interactions could occur along the annual ice road system connecting the proposed LDPI to the Endicott SDI because this road would be present each winter and spring throughout the five-year life of the development project (USFWS, 2011). Because these impacts would be long-term and could result in adverse minor impacts to local population levels individual animals, ice road construction and use would have moderate minor effects to polar bears. This level of effect would be reduced to minor negligible with the implementation of mitigation measures described in Appendix C, particularly pre-activity maternal den surveys. This, coupled with reactive mitigation measures designed to minimize anthropogenic impacts to recently discovered dens in the area, , which would greatly reduce the potential for impacts to pregnant females and denning family units.

Mine Site Development

As with ice road construction and maintenance activities, the spatial and temporal extent of the mine site development overlaps with winter and spring polar bear critical habitat and both denning females with new-born young and non-denning polar bears may be found in the area. Likewise, mine site activities have the potential to disturb and displace individuals, alter or remove polar bear critical habitat, increase the likelihood of human-bear interactions, and contribute to injury or mortality of individual polar bears. These impacts have been discussed in Ice Road Construction and Use, above; only aspects specific to development of the proposed mine site that have not previously been are addressed are discussed further.

Disturbance and Displacement

Construction of the mine site would involve multiple blasting events to remove substrate and this could cause denning and non-denning polar bears to avoid or vacate the area. For transient bears this displacement would be brief and would not result in long-term effects to bear health. Females with recently-birthed young could abandon nearby maternal dens; early den abandonment can have adverse consequences on the health, growth, and survival of both mothers and offspring. Such impacts can be short-term and acute as well as have long-term, chronic effects to individuals. Blasting would occur for a brief period during one season.

The temporal and geographical extent of potential exposure to polar bears would be extremely limited.

Habitat Loss and Alteration.

Mine site development for the Proposed Action would result in both short-term and long-term impacts to potential polar bear critical habitat. Excavation would permanently remove approximately 21 acres of land, some of it critical habitat (terrestrial denning) because the proposed mine site remediation would convert the excavated footprint to artificial aquatic habitat (Hilcorp, 2015). It is possible that remediation could produce topographical features around the perimeter of the site that are conducive to maternal denning; however the likelihood and extent to which this could occur is not presently known.

In addition to the 28-acre ice pad surrounding the mine site, construction and emergency response offices would be stationed on a 45-acre grounded pond south of the Badami seasonal ice road (Hilcorp, 2015, Figure 10-2,). These offices would be accessed via an approximately 0.4-acre ice road spur off of the Badami ice road. These facilities would make some critical habitat unavailable for use for one winter but no long-term alterations or loss of habitat would result from these temporary facilities.

Conclusion

Potential for impacts to polar bears from mine site development activities would be seasonal and would not persist longer than a 6-month period during Year 2. Critical habitat (terrestrial denning habitat) loss could occur at the excavation site because of proposed remediation plans to convert the area to aquatic habitat; however the amount of habitat removed would comprise a very small portion of the habitat available to polar bears. Furthermore, USFWS does not consider denning habitat to be limiting the population size of the SBS polar bear stock (C. Perham, pers. comm. in USDOJ, USFWS, 2008). The blasting events would be the one activity which could affect polar bears the most. While such impacts can be short-term and acute as well as have long-term, chronic effects to individuals, any individuals at maternal den sites within the vicinity could be impacted by the blasting. The blasting effects and because activities themselves would occur over a relatively short time period and long-term impacts would be limited to localized critical habitat alteration, mine site development would have moderate effects to polar bears. While implementation of mitigation measures described in Appendix C would not reduce the impact level to negligible, they would lessen the potential for disturbance, displacement, and human-polar bears interactions during mine site activities.

LDPI Construction

LDPI construction would have the greatest potential to impact polar bears during winter and spring months because bears are more likely to occur in the Proposed Action Area during that time (Section 3.2.4.4). Polar bears are occasionally reported by industry during the open-water season (e.g., Bisson et al., 2013); bears encountered in the water or on land during proposed LDPI construction could also be affected by proposed LDPI construction activities.

LDPI construction could disturb and displace transient individuals and family units, alter polar bear critical habitat, increase the likelihood of human-bear interactions, and contribute to injury or mortality of individual polar bears. These impacts have been discussed in Ice Road Construction and Use, above; aspects specific to construction of the proposed LDPI that have not previously been addressed in the sections that follow.

Disturbance and Displacement.

In addition to noise and presence of ground traffic and construction vehicles, construction of the proposed LDPI would require the support of helicopters, hovercraft and vessels. The noise and presence of aircraft and vessels can disturb and temporarily displace polar bears, although responses can vary greatly among individuals (Richardson et al., 1995).

Underwater construction sounds would have minimal effect to on-ice polar bears because bears are unlikely to hear underwater sound above ice (USDOJ, USFWS, 2012). Swimming bears would also be minimally affected by underwater sounds (e.g., sheetpile-driving) because sound in open water would be attenuated; additionally, polar bears generally do not dive much below the surface and they normally swim with their heads above the surface, where noises produced underwater are weak (Greene and Richardson, 1988; Richardson et al., 1995).

Aircraft. Under the Proposed Action, aircraft to support construction would transit between the proposed LDPI and Deadhorse and/or the Endicott SDI, with 1-2 helicopter trips occurring per day (Table 2.1.5-2). Polar bears are known to run from sources of noise and the sight of aircraft, especially helicopters (Amstrup, 1993; Bishop and Streever, 2016; Richardson et al., 1995; Streever and Bishop 2014). The effects of fleeing from aircraft are likely to be minimal if the event is temporary, the animal is otherwise non stressed, and the flight occurs in low ambient temperatures. However, with increased temperatures, a short run may be enough to overheat a polar bear, and a bear already experiencing stress that swims a long distance could require rest for a long period prior to reinitiating essential life functions such as feeding. Persistent aircraft travel could displace polar bears from localized areas in the flight path (USDOJ, USFWS, 2012). Additionally, small cubs could become separated from their mothers (USDOJ, USFWS, 2012). Denning bears may also abandon or depart their dens early in response to repeated noise produced by extensive aircraft overflights (Amstrup, 1993; USDOJ, USFWS, 2011).

Vessels. If an encounter between a vessel and a swimming bear were to occur, it would most likely result in only a minor disturbance (e.g., the bear may change its direction or temporarily swim faster) as the vessel passes the swimming bear (USDOJ, USFWS, 2012). Although it has not been thoroughly documented, persistent disturbance from vessels operating within one lateral mile (1.6 km) of barrier islands could prevent use of localized areas of barrier island critical habitat (USDOJ, USFWS, 2012). However, vessel traffic to support the proposed LDPI construction would only occur between West Dock and the LDPI or Endicott SDI and the LDPI and, therefore, is not expected to prevent use of the remaining habitat.

Habitat Loss and Alteration.

Construction of the proposed LDPI would turn approximately 24 acres of marine sea ice critical habitat into a man-made island. Anthropogenic activity associated with the island would limit its ability to be used for any reason by polar bears. In the past, polar bears have used man-made islands on the North Slope for denning and resting areas. In 2011, a polar bear denned in the terraced gravel bags that armor some of the offshore islands. She selected her location during a lull in island construction in the fall when no activity was occurring and she emerged after activity had started again. Due to the mitigation measures and the voluntary abandonment of the island by construction personnel she successfully abandoned the island with her offspring. In addition, bears constantly use the man-made offshore islands as resting sites and are sometimes dispersed by safety personnel after they are discovered. Depending on the tolerance level of individual polar bears to human activities, bears may use structures as resting areas (USDOJ, USFWS, 2012). Multiple bears have used Oooguruk, Northstar, and the West Dock and Endicott causeways for resting and traveling (Bishop and Streever, 2016; USDOJ, USFWS, 2012).

Human-Bear Interactions.

Facilities to support 100 construction and drilling personnel would be installed on the proposed LDPI (Hilcorp, 2015). The increase in personnel would increase the likelihood of human-bear interactions, as described in Ice Road Construction and Use. However, the proposed LDPI was engineered to minimize access by polar bears (Hilcorp, 2015); therefore the increase in potential encounters is less than if the same support facilities and personnel were stationed onshore.

Conclusion

The duration of potential for impacts from proposed LDPI construction would be less than one year and most potential impacts would be no more than short-term behavioral responses. Long-term sea ice critical habitat alteration would occur at the LDPI; however, the amount of habitat altered would comprise a very small portion of the sea ice habitat available to polar bears. Because activities themselves would occur over a relatively short time period and long-term impacts would be limited to localized critical habitat alteration that could marginally increase potential for human-bear interactions, LDPI construction would have minor effects to polar bears and a negligible effect on polar bear populations. While implementation of mitigation measures described in Appendix C would not reduce the impact level to negligible, they would lessen the potential for disturbance, displacement, and human-polar bears interactions from proposed LDPI construction. Impacts on individual bears could occur, but impacts at the population level are not expected to rise above minor.

Pipeline Installation

Pipeline installation could disturb and displace denning and transient individuals and family units, alter polar bear critical habitat, increase the likelihood of human-bear interactions, and contribute to injury or mortality of individual polar bears. These impacts have been discussed in previous sections; aspects specific to pipeline installation that have not previously been addressed in the sections that follow.

Habitat Loss and Alteration.

Construction of the offshore portion of the pipeline would temporarily alter some polar bear critical habitat from use. These impacts have been discussed in previous sections; aspects specific to pipeline installation that have not previously been addressed in the sections that follow.

Habitat Loss and Alteration.

Construction of the offshore portion of the pipeline would temporarily remove some polar bear habitat. Ringed seals could be disturbed and displaced from the immediate area, potentially altering their distribution and availability to polar bears. These impacts would be localized and temporary, persisting for only one winter and spring.

Staging areas and support facilities would make some potential denning habitat unavailable during construction of the onshore portion of the pipeline as with the offshore portion of the pipeline, this impact would not persist longer than one winter and spring. Pre-construction den detection surveys could take place to identify any maternal den sites in the footprint of proposed staging areas, support facilities, and shore-crossing. These mitigation measures would need to be approved by the USFWS.

Installation of Vertical Support Members (VSMs) and a new gravel pad for pigging facilities at the Badami tie-in would permanently remove approximately 0.6 acres of potential denning habitat. However, the edges of the gravel pad could create suitable denning habitat if sufficient drifting snow accumulates. The onshore pipeline would be elevated a minimum of 7 ft (2.1 m) to prevent it from hindering wildlife movements, including polar bears.

Construction of the approximately 300 ft (91.4 m) long pipeline shore-crossing would temporarily alter critical habitat along to coast, an important transit area for non-denning polar bears. The unavailability of this area would be short-term, lasting no longer than one winter and spring (Hilcorp, 2015). Construction of the shoreline crossing may have long-lasting impacts to polar bear denning habitat, however. Coastal bluffs at the interface between mainland and marine habitat are areas of relatively greater denning use (Durner et al. 2004; Durner et al. 2006). Installation of a thaw stable gravel plug near the waterline as well as backfill could modify topographical features at this interface. Gravel placement could create habitat conducive to denning and/or decrease or remove the physical characteristics key to suitable denning habitat (USDOJ, USFWS, 2012).

The approximately 10 ft (3.1 m) tall thermal siphons installed along the length of the shore crossing could be perceived as an obstacle to transiting bears if they are especially sensitive to the presence of human structures. More likely, however, polar bears would have no difficulty in navigating the siphons; bears regularly move through areas of much more pervasive infrastructure (USDOI, USFWS, 2012).

Human-Bear Interactions.

An additional temporary camp housing unit up to 125 workers may be installed onshore during the 3Q Year 2 to support pipeline and facilities installation (Hilcorp, 2015). The increase in personnel as well as the additional camp (a potential source of attractants) would increase the likelihood of human-bear interactions, as described in Ice Road Construction and Use.

Conclusion

Potential for most impacts to polar bears from pipeline installation would be less than one year would result in no more than short-term behavioral responses. Long-term critical habitat alteration would occur at the gravel tie-in pad, the shoreline crossing and VSM locations; however, the amount of critical habitat altered would comprise a very small portion of the terrestrial denning critical habitat available to polar bears. Because activities themselves would occur over a relatively short time period and long-term impacts would be limited to localized critical habitat alteration, pipeline installation would have minor effects to polar bears.

While implementation of mitigation measures described in Appendix C would not reduce the impact level to negligible, they would lessen the potential for disturbance, displacement, and human-polar bears interactions during pipeline installation activities.

Facilities Construction

Facilities construction activities could impact polar bears in the manners described in Ice Road Construction and Use and proposed LDPI Construction, including disturbance and displacement of denning and non-denning bears, increased likelihood of human-bear interactions, and contribution to injury or mortality of individual polar bears. These impacts have been discussed in previous sections; aspects specific to facilities construction that have not previously been addressed are discussed in the sections that follow. No impact to habitat beyond that already described in previous sections is anticipated.

Disturbance and Displacement.

In addition to aircraft, crew boat, and ground traffic, facilities construction would be supported by barge and tug traffic. Vessel traffic would transit in-between offshore and nearshore barrier island habitat (Figure 2.1.1-2). Exact routes would be dependent on weather and safety conditions, however, barges passing within 1 mi (1.6 km) of barrier islands could disturb and displace polar bears from barrier island critical habitat (USDOI, USFWS, 2012).

During the open-water season polar bears, including family units, are periodically observed at the Endicott SDI (Bishop and Streever, 2016; Streever and Bishop, 2013; Streever and Bishop, 2014). Facilities construction activities at Endicott could disturb polar bears resting or traveling the SDI, and the chance of human-bear interactions would be increased. However, bears using the Endicott SDI are likely habituated to or at least tolerant of the level of human activity that occurs there, otherwise they would avoid the area.

Summary.

Potential for impacts to polar bears from facilities construction would occur intermittently over a 3-year period, with the greatest potential during the second autumn of the Proposed Action, when the majority of facilities to support personnel and construction would be installed. Temporary disturbance

and localized displacement could occur, and as could human-bear interactions. Because activities themselves would occur over a relatively short time period and no long-term impacts (such as critical habitat loss) are anticipated, facilities construction would have minor effects to polar bears. While implementation of mitigation measures described in Appendix C would not eliminate impacts, they would lessen the potential for disturbance, displacement, and human-polar bears interactions during construction activities.

Drilling Operations

Drilling would commence in the second winter (1Q Year 3) and continue for two years (through 1Q Year 5). Operations would be supported by resupply via ice roads and, to a lesser extent, summer barges (at an estimated 20 trips per year).

Drilling operations could impact polar bears via disturbance, increased potential for human-bear interactions, and contribution to injury or mortality of individual polar bears. These impacts have been discussed in previous sections; aspects specific to drilling operations that have not previously been addressed in the sections that follow.

Drilling operations introduce the potential for a large spill to occur. Impacts of large spills to polar bears are presented in Oil Spills – Large.

Disturbance and Displacement.

Polar bears near routine industrial activities may habituate to these stimuli and show less vigilance than bears not exposed to such stimuli (USDOJ, USFWS, 2012). For example, in 2011, a female bear dened throughout the winter on an active industrial island and only became known to the company when she naturally emerged from her den site approximately 50 meters from human activity. She eventually abandoned her den naturally with her offspring (USDOJ, USFWS, 2012). Habituation to stimulus such as noise is generally considered to be positive because polar bears may experience less stress from industrial activity; however, it may also increase the risk of human-bear encounters.

Underwater drilling noise during the open-water season would be unlikely to affect polar bears because they do not dive much below the surface and typically swim with their heads out of the water (Richardson et al., 1995). Underwater drilling noise produced during periods of sea ice coverage would have minimal effect on polar bears because ice would prevent noise attenuation (USDOJ, USFWS, 2012).

Construction and drilling operations would occur concurrently for several years (Figure 2-1). The number of vessel and surface vehicle trips would increase during this period, which would result in greater potential for disturbance and displacement of polar bears on land or ice or in dens. Impacts from marine and surface traffic are discussed further in proposed LDPI Construction and Facilities Construction, and Ice Road Construction and Use, respectively.

Aircraft traffic would continue to support project activities during drilling but at a greater frequency than during construction activities (2 trips per day during drilling vs. 1-2 trips per day during construction) (Table 2.1.5-2). Correspondingly, the potential for disturbance or displacement of polar bears from aircraft overflights during drilling operations would be comparable or higher than during construction. As detailed in proposed LDPI Construction, impacts from aircraft noise and presence would be short-term and produce at most behavioral responses.

Summary

Potential for impacts to polar bears from drilling operations would be continuous over a 2-year period, temporary disturbance and localized displacement could occur, and as could human-bear interactions. Because no long-term impacts, such as critical habitat loss, are anticipated, production operations would have minor effects to polar bears. While implementation of mitigation measures

described in Appendix C would not eliminate impacts, they would lessen the potential for disturbance, displacement, and human-polar bears interactions during production.

Production Operations

Production would commence after the completion of the first three wells. It is anticipated that first oil would be produced in during the third winter (1Q Year 4). Construction and drilling activities would be ongoing during that time. By 1Q Year 5 drilling would likely be complete and only production-related activities would continue.

Production-related activities focus on the operation and maintenance of facilities and equipment (Section 2.1.5). Operations would continue to be supported by resupply via ice roads and, to a lesser extent, summer barges (at an estimated 10 trips per year). Aerial helicopter surveillance would be conducted of the offshore and onshore pipeline corridor on a weekly or other periodic basis. A bathymetry vessel would survey the offshore pipeline annually during the open-water season.

The types of potential impacts to polar bears from production operations would be the same as those from drilling operations; however, the likelihood of occurrence would be relatively less. Fewer personnel would be needed once construction and drilling are complete. A reduction in personnel would result in relatively fewer aerial, vessel, and ground vehicle trips for crew transport and resupply (Hilcorp, 2015, Tables 5-3, 5-4, and 5-5), and generation of fewer attractants (e.g., food waste).

Summary

The potential for impacts to polar bears from production operation would be continuous over a 22-year period. Temporary disturbance and localized displacement could occur, and as could human-bear interactions. Because no long-term impacts (such as habitat loss) are anticipated, production operations would have negligible effects to polar bears. While implementation of mitigation measures described in Appendix C would not eliminate impacts, they would lessen the potential for disturbance, displacement, and human-polar bears interactions during production.

Decommissioning

Decommissioning would occur over an 18-month period; the removal of facilities and abandonment of wells would likely require two winter seasons. Under the Proposed Action it is anticipated that all installed surface facilities associated with the Proposed Action would be removed, including proposed LDPI slope protection, the onshore pipeline and VSMS. The subsea pipeline would be flushed of all contaminants, ends cut and sealed, and abandoned in place. The proposed LDPI likely would be left in place to allow waves and currents to reshape the proposed LDPI naturally.

Decommissioning could impact polar bears via disturbance and displacement, increased potential for human-bear interactions, and contribution to injury or mortality of individual polar bears. The likelihood and duration of these impacts would be comparable to those described in previous sections (e.g., impacts from removal of on-proposed LDPI modular facilities would be similar to impacts from module installation).

The abandoned LDPI and gravel pads (as they erode or if they are not removed) could provide polar bears with additional barrier island and denning habitat. For example, the Staging Pad, an isolated, abandoned gravel pad isolated approximately seven km (4.3 mi) northeast of the Milne Point Central Processing Facility, is the most consistent location of polar bear denning on the North Slope; eight maternal dens have occurred on this man-made pad in the last nine years. Bears have also successfully denned on a decommissioned exploration gravel pad on Cross Island and on the runway ramp at the Bullen Point LRRS (USDOI, USFWS, 2012).

Summary

The duration of potential for impacts from decommissioning would persist for no more than approximately 18 months. Most potential impacts would be no more than short-term behavioral responses. Abandonment of the proposed LDPI and gravel pad sites could provide polar bears with additional potential habitat (if not removed). Because activities themselves would occur over a relatively short time period and long-term impacts would be limited to localized habitat alteration, decommissioning would have minor effects to polar bears. While implementation of mitigation measures described in Appendix C would not reduce the impact level to negligible, they would lessen the potential for disturbance, displacement, and human-polar bears interactions during decommissioning activities.

Oil Spills

Polar bears can occur in the Action Area year-round and therefore have the potential to be affected by oil spills during any season. An oil spill in the fall or spring during the formation or break-up of sea ice would be a greater risk to polar bears than spills occurring at other times of year because of difficulties associated with clean up during these periods, and the presence of bears in the prime feeding areas over the continental shelf (Amstrup, Durner, and McDonald, 2000; Amstrup et al., 2006; Helm et al., 2015; USDO, USFWS, 2015cjp). During the autumn freeze-up and spring break-up periods, any oil spilled in the marine environment would likely concentrate and accumulate in open leads and polynyas, areas of high activity for both polar bears and seals (Helm et al., 2015; Neff, 1990). The potential impacts of a spill would be greatest where polar bears are relatively aggregated, such as Barter and Cross Islands during the fall open-water period (Amstrup, Durner, and McDonald, 2000; Amstrup et al., 2006; Helm et al., 2015; USDO, USFWS, 2015cjp).

Polar bears that come into contact with crude or refined oil could experience acute and long-lasting effects, including irritation to eyes, mouth, and mucus membranes, irritation and damage to respiratory organs from inhalation, and kidney and liver damage from ingestion of contaminated prey (Ortisland et al., 1981). Contact with and ingestion of petroleum by polar bears can also cause hair loss, anemia, anorexia, increased metabolic rate, elevated skin temperatures, and stress response (Derocher and Stirling, 1991, St. Aubin, 1990).

Polar bears scavenge animal carcasses; it is unclear whether polar bears would avoid contaminated carcasses. In addition, polar bears are known to be attracted to petroleum products and can be expected to actively investigate oil spills; they also are known to consume foods fouled with petroleum products (Derocher and Stirling, 1991; St. Aubin, 1990). Oiled polar bears would likely ingest oil during grooming efforts and would be susceptible to hypothermia. Heavily oiled bears would not survive unless capture and cleaning efforts were successful (Ortisland et al., 1981). Further detailed information on the physiological impacts of oil contact to marine mammals is presented in Section 4.3.4, Accidental Oil Spills.

Small

Small spills (<1,000 bbl) of refined oil could occur during construction, drilling, production, and decommissioning. Small spills of crude oil could occur during drilling and production.

In the event that a small spill occurred, individual polar bears or their prey could come into contact with oil. However, a small spill is unlikely to contact polar bears, even if it entered water bodies or wetlands, because polar bears are sparsely distributed (USDO, USFWS, 2012). Additionally, most small spills assumed to occur during the Proposed Action would be 2-3 bbl (with an average of 0-9 bbl spilled annually) and a 3-bbl refined oil spill evaporates and disperses within 24 hours during summer months (Appendix A).

If an individual polar bear contacted or ingested oil it could experience acute and chronic physiological impacts, up to and including mortality. The OSRA analyses in Appendix A shows a small winter spill could not contact any lead or polynya systems making it unlikely any polar bears could come into contact with oil spilled under the ice. Furthermore, it is unlikely polar bears would contact small spills, and even if such an event were to occur, any adverse effects to a single or few individuals could not cause population-level effects. For these reasons small spills would have negligible effects on polar bears. Those impacts would be further reduced by spill response such as containment by booms or absorbent pads that may help prevent small spills from reaching the water, or by burning off the spilled materials (Alaska Clean Seas 2016).

Large

A large spill ($\geq 1,000$ bbl) could occur during drilling or production; however, the OSRA estimates that there is a 99.33% chance of no large spills occurring during the Proposed Action (Appendix A). Because large spills are of important concern, BOEM assumes a large spill could occur and conducts a large oil spill analysis for the development and production activities (Section 4.1.1.1).

In the unlikely event of such an oil spill, the extent of impact would be influenced greatly by the volume, trajectory, and timing of the spill as well as the period that oil remains in the environment (Amstrup, Durner, and McDonald, 2000; Amstrup et al., 2006; Helm et al., 2015). Polar bears present in the vicinity of an oil spill might or might not be contacted by the oil due to personal preferences, avoidance or attraction behavior, ice conditions, or weather patterns, and questionable whether polar bears avoid or are attracted to oil (Geraci and St. Aubin, 1990). If a large oil spill occurred in the vicinity of an aggregation of polar bears, any the substantial loss of individual bears would represent a major impact to the local population (Amstrup, Durner, and McDonald, 2000; Amstrup et al., 2006; Helm et al., 2015; USDO, MMS, 2002).

Oil-Spill Analysis

Detailed background on BOEM's OSRA process is provided in Appendix A. The OSRA model estimates the conditional and combined probabilities of a large spill contacting a geographic area (i.e., environmental resource area (ERA), land segment (LS), grouped land segment (GLS)) important to one or several species or species groups during a discrete amount of time. A list of polar bear ERAs and GLSs can be found in Appendix A, Table A.1-5. Oil-spill impacts to ice seals, such as ringed seals, could impact polar bears by limiting prey available to them, or by causing mortality from secondary contamination. Impacts to ice seals are presented in Sections 4.3.4.3 through 4.3.4.5.

ERAs and GLSs (no LSs were identified for polar bears) analyzed in this section are those for which the conditional probability of large spill contact was found to be $\geq 5\%$ at any point within 360-days of a spill occurring. The conditional probabilities of those ERAs and GLSs for which contact was $< 5\%$ can be found in Appendix A). The ERAs and GLSs discussed in this section are:

- ERA 92 – Thetis, Jones, Cottle and Return Islands, important polar bear barrier island critical habitat and maternal denning habitat; vulnerable to large spills year-round;
- GLS 176 – Land Segments 98 through 129, important summer coastline critical habitat for polar bears; vulnerable to large spills from June through August;
- GLS 178 – Land Segments 104 through 129, important fall coastline critical habitat for polar bears; vulnerable to large spills from September through November; and
- GLS 179 – Foggy Island Bay, important polar bear coastline critical habitat and maternal den habitat; vulnerable to spills year-round (Appendix A, Table A.1-5).

Maps of these polygons are presented in Appendix A.

Conditional Probabilities

The OSRA model calculates conditional probabilities (expressed as a percent chance) of a spill contacting identified polar bear habitats (ERA polygons, LSs, or GLSs). Conditional probabilities are based on the assumption that a large spill has occurred (for further explanation, see Appendix A). For a map of the hypothetical spill sources (proposed LDPI and pipeline) used for the oil-spill-trajectory analysis, see Appendix A, Map A-6.

Summer Spills. A large spill during summer (July 1 through September 30) could impact polar bears coming ashore due to sea-ice retreat or in preparation for denning later in the fall/winter season. The areas in the Beaufort Sea that would be particularly important include barrier islands where bears may den as well as rest after long swims to shore from the pack ice edge, and the main coastline, an important travel corridor to access terrestrial denning critical habitat and winter sea ice foraging areas (Derocher et al., 2013; Fischbach et al., 2007; USDOL, USFWS, 2015cjp). The conditional probabilities of a summer large spill from the proposed LDPI or the pipeline contacting a polar bear ERA or GLS are presented in Table 4.3.4-9A.

Winter Spills. A large spill during winter (October 1 through June 30) could impact polar bears on nearshore or offshore ice or at polynyas and open lead systems. A large spill in winter would be difficult to clean up, and oil could become entrained in the ice, melting out in spring and contacting lead systems and coastal areas. In winter, polar bears range throughout the ice-covered waters of the Beaufort Sea (Section 3.2.4.4). They may be found near polynyas and open leads where they prey on seals. In spring, new family units emerge from dens and could come into contact with oil that has melted out of the ice. The conditional probabilities of a winter large spill from the proposed LDPI or the pipeline contacting a polar bear ERA or GLS are presented in Table 4.3.4-9B.

Table 4.3.4-12. Summer Conditional Probabilities of a Large Spill Contacting a Polar Bear ERA or GLS.

Resource Area	Source	1 day	3 days	10 days	30 days	90 days	360 days
ERA 92	LI	<0.5	2%	8%	10%	11%	11%
ERA 92	PL	<0.5	1%	3%	<0.5	5%	5%
GLS 176	LDPI	12%	28%	40%	43%	43%	43%
GLS 176	Pipeline	27%	40%	46%	48%	48%	48%
GLS 178	LDPI	12%	25%	30%	30%	30%	30%
GLS 178	Pipeline	26%	34%	37%	37%	37%	37%
GLS 179	LDPI	24%	48%	57%	58%	58%	58%
GLS 179	Pipeline	53%	72%	77%	78%	78%	78%

Notes: Summer = July 1-September 30. ERA = Environmental Resource Area. GLS = Grouped Land Segment.

Table 4.3.4-13. Winter Conditional Probabilities of a Large Spill Contacting a Polar Bear ERA or GLS.

Resource Area	Source	1 day	3 days	10 days	30 days	90 days	360 days
ERA 92	LI	<0.5%	2%	7%	10%	10%	10%
ERA 92	PL	<0.5	<0.5	<0.5	<0.5	<0.5	<0.5
GLS 176	LDPI	4%	10%	14%	16%	17%	17%
GLS 176	Pipeline	5%	13%	16%	17%	18%	18%
GLS 178	LDPI	4%	9%	13%	14%	14%	14%
GLS 178	Pipeline	11%	16%	18%	18%	19%	19%
GLS 179	LDPI	21%	46%	55%	57%	57%	57%
GLS 179	Pipeline	51%	69%	76%	77%	77%	77%

Notes: Winter = October 1 through June 30. ERA = Environmental Resource Area. GLS = Grouped Land Segment.

Combined Probabilities

Combined probabilities differ from conditional probabilities in that there is no assumption that a large spill has occurred. Instead, combined probabilities reflect the chance of one or more large spills

occurring over the life of the Proposed Action, and of any portion of that spill contacting any portion of a particular ERA. Combined probabilities do not factor in any cleanup efforts. For more background information, see Appendix A, Section A-1.6.1.

The OSRA model found the combined probabilities of a large spill occurring and contacting a polar bear ERA or GLS within 360 days to be <1%, regardless of whether the spill occurred during winter or summer months.

Polar Bear Habitat

BOEM considered large offshore habitat areas in addition to the ERAs and GLSs input into the OSRA trajectory model for polar bears shown in Appendix A, Table A.1-5. Some of this habitat considered was polar bear critical habitat (particularly the sea ice critical habitat unit). Information gathered through study of tagged polar bears in the southern Beaufort Sea and the Chukchi Sea was integral to developing a robust analytical approach, and therefore is presented here as necessary background.

Southern Beaufort Sea. In 2013, BOEM received a final report for a BOEM-funded study led by Dr. Andrew Derocher of the University of Alberta (Derocher et al., 2013). The results of the study included habitat analyses based upon 65 collared female and sub-adult polar bears. The polar bears were collared in the eastern portion of the southern Beaufort Sea. Movement data from these polar bears were used to delineate important polar bear habitat in the southern Beaufort Sea. Dr. Derocher and his team identified areas used by polar bears in spring, winter, fall and summer during 2007-2010 (Derocher et al., 2013; Figure 13). BOEM used the minimum convex polygon (95%) and seasonal and annual kernel home ranges (75% for all polar bears) monitored by GPS satellite telemetry (Derocher et al., 2013; Figure 13) to determine the polygons used for polar bear habitat by season (Figure 4.3.4-13).

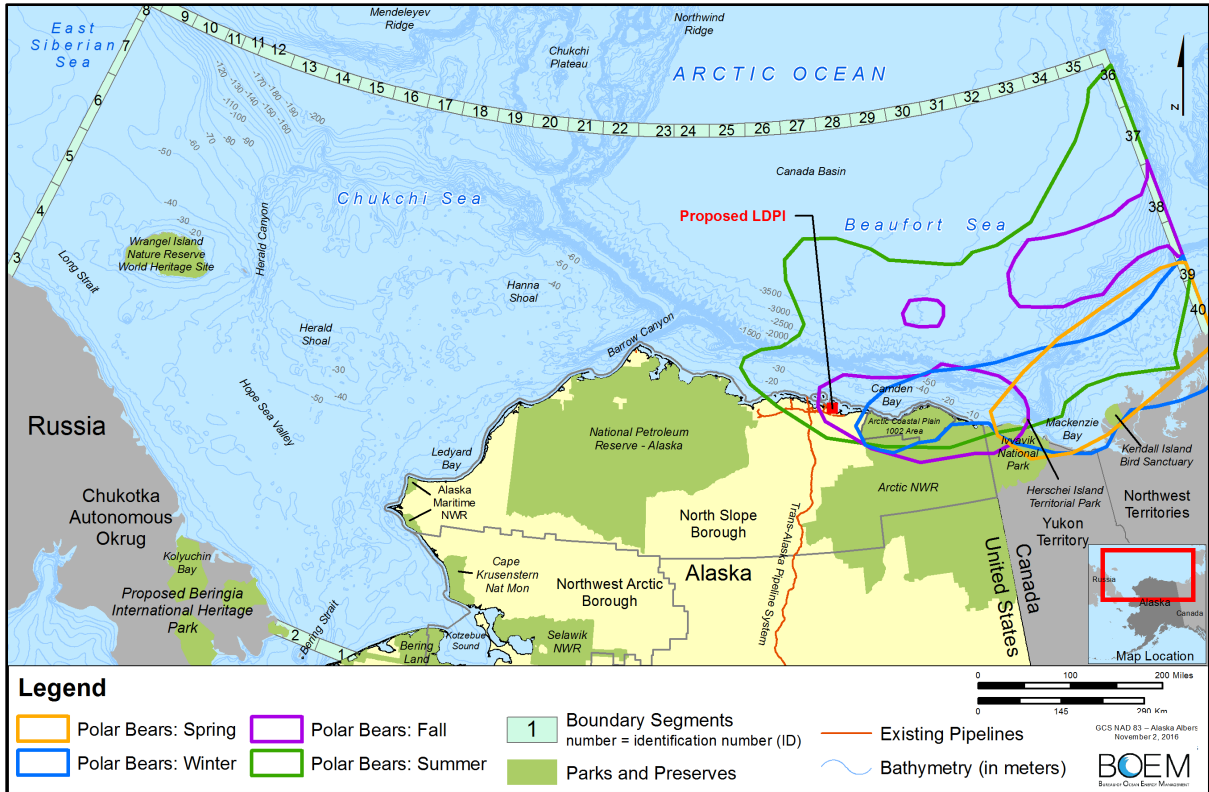

Figure 4.3.4-14. Beaufort Sea Polar Bear Habitat by Season. Illustration based on actual collared female and sub-adult polar bears from the southern Beaufort Sea population. Source: Derocher et al., 2013; Figure 13.

Each seasonal habitat area was analyzed as a polygon in the OSRA model. Due to the large size of the habitat polygons, a gridded overlay methodology was used to assess whether any portion of each polygon would be contacted by a large spill starting from any of the launch points. These are conditional probabilities; the estimate is based on assuming that a large spill has occurred. This chance of contact has not been weighted by the chance of one or more large spills occurring. In the analysis, a large spill originating between July 1 and September 31 is identified as a summer spill, while a large spill originating between October 1 and June 30 is identified as a winter spill. Tables 4.3.4-10 through 4.3.4-13 show the percent chance of contact by season and are further analyzed below.

Table 4.3.4-14. Polar Bear Habitat¹ Grid Cells and Chance of Contact during Summer.

Spill Source	Season	Days	<0.5% of Grid Cells Contacted	Total Grid Cells Contacted	Percent Chance of Contact to Habitat	Percent Chance of ≥2 Habitat Cells Contacted	>99.5% of Grid Cells Contacted
LI	Summer	3	1891	31	1-58%	1-13%	1
LI	Summer	30	1720	202	1-62%	1-13%	1
LI	Summer	360	1661	261	1-63%	1-13%	1
LI	Winter	3	1899	23	1-68%	1-5%	1
LI	Winter	30	1736	186	1-71%	1-15%	1
LI	Winter	360	1644	278	1-71%	1-15%	1
PL	Summer	3	1900	22	1-62%	1-5%	<0.5
PL	Summer	30	1773	149	1-64%	1-9%	<0.5
PL	Summer	360	1713	209	1-64%	1-9%	<0.5

Spill Source	Season	Days	<0.5% of Grid Cells Contacted	Total Grid Cells Contacted	Percent Chance of Contact to Habitat	Percent Chance of ≥2 Habitat Cells Contacted	>99.5% of Grid Cells Contacted
PL	Winter	3	1903	19	1-65%	1-5%	<0.5
PL	Winter	30	1778	144	1-66%	1-6%	<0.5
PL	Winter	360	1716	206	1-66%	1-6%	<0.5

Notes: Table indicates the number of grid cells within the polar bear habitat1 by season and the percent chance of contact from launch points within 3, 30 or 360 days.
 SBS= Southern Beaufort Sea stock of polar bear. BOEM used the minimum convex polygon (95%) and seasonal and annual kernel home ranges (75% for all polar bears) monitored by GPS satellite telemetry from Derocher et al. (2013).

Table 4.3.4-15. Polar Bear Habitat¹ Grid Cells and Chance of Contact during Fall.

Spill Source	Season	Days	<0.5% of Grid Cells Contacted	Total Grid Cells Contacted	Percent Chance of Contact to Habitat	Percent Chance of ≥2 Habitat Cells Contacted	>99.5% of Grid Cells Contacted
LI	Summer	3	543	23	1-58%	1-13%	1
LI	Summer	30	476	90	1-62%	1-13%	1
LI	Summer	360	467	99	1-63%	1-13%	1
LI	Winter	3	548	18	1-68%	1-2%	1
LI	Winter	30	494	72	1-71%	1-15%	1
LI	Winter	360	478	88	1-71%	1-15%	1
PL	Summer	3	547	19	1-62%	1-5%	<0.5
PL	Summer	30	493	73	1-64%	1-9%	<0.5
PL	Summer	360	481	85	1-64%	1-9%	<0.5
PL	Winter	3	551	15	1-65%	1-5%	<0.5
PL	Winter	30	504	62	1-66%	1-6%	<0.5
PL	Winter	360	496	70	1-66%	1-6%	<0.5

Notes: Table indicates the number of grid cells within the polar bear habitat1 by season and the percent chance of contact from launch points within 3, 30 or 360 days.
 SBS= Southern Beaufort Sea stock of polar bear. BOEM used the minimum convex polygon (95%) and seasonal and annual kernel home ranges (75% for all polar bears) monitored by GPS satellite telemetry from Derocher et al. (2013).

Table 4.3.4-16. Polar Bear Habitat¹ Grid Cells and Chance of Contact during Winter.

Spill Source	Season	Days	<0.5% of Grid Cells Contacted	Total Grid Cells Contacted	Percent Chance of Contact to Habitat	Percent Chance of ≥2 Habitat Cells Contacted	>99.5% of Grid Cells Contacted
LI	Summer	3	586	<0.5		<0.5%	<0.5
LI	Summer	30	549	37	1-3%	1-3%	<0.5
LI	Summer	360	541	45	1-3%	1-3%	<0.5
LI	Winter	3	586	<0.5	<0.5	<0.5%	<0.5
LI	Winter	30	567	19	1-2%	1-2%	<0.5
LI	Winter	360	551	35	1-2%	1-2%	<0.5
PL	Summer	3	586	<0.5		<0.5%	<0.5
PL	Summer	30	563	23	1-3%	1-2%	<0.5
PL	Summer	360	554	32	1-3%	1-2%	<0.5
PL	Winter	3	586	<0.5	<0.5	<0.5%	<0.5
PL	Winter	30	573	13	1-2%	1-2%	<0.5
PL	Winter	360	568	18	1-2%	1-2%	<0.5

Notes: Table indicates the number of grid cells within the polar bear habitat1 by season and the percent chance of contact from launch points within 3, 30 or 360 days.
 SBS= Southern Beaufort Sea stock of polar bear. BOEM used the minimum convex polygon (95%) and seasonal and annual kernel home ranges (75% for all polar bears) monitored by GPS satellite telemetry from Derocher et al. (2013).

Table 4.3.4-17. Polar Bear Habitat¹ Grid Cells and Chance of Contact during Spring.**<0.5 % Chance of Contact for all sources, seasons and days to any grid cell**

Notes: Table indicates the number of grid cells within the polar bear habitat¹ by season and the percent chance of contact from launch points within 3, 30 or 360 days.

SBS= Southern Beaufort Sea stock of polar bear. BOEM used the minimum convex polygon (95%) and seasonal and annual kernel home ranges (75% for all polar bears) monitored by GPS satellite telemetry from Derocher et al. (2013).

Summer Habitat. Polar bears are widely distributed during summer months; this is reflected in the large number of cells (n=1922) comprising the summer habitat. Because the summer habitat is a much larger than that identified by Derocher et al. (2013) for the other three seasons, there are more opportunities (i.e., cells) for a spill to contact any portion of that habitat. The likelihood of a spill contacting polar bear summer habitat would be greatest if a large spill occurred from the proposed LDPI during winter (up to a 71% chance of contacting 1 cell within 30 or 360 days). For each location and season, the chance of a large spill contacting more than one individual cell never exceeds 15%.

A spill from the proposed LDPI during winter has a chance of contacting a slightly larger amount of polar bear habitat than during summer (up to 278 versus 261 cells), although a spill occurring during winter would disperse more slowly than a summertime spill (e.g., contacting 19 to 23 cells in 3 days vs. 22 to 31 cells in 3 days). In general, a spill from the proposed subsea pipeline would have slightly less potential impact to polar bear summer habitat than a spill from the proposed LDPI.

Fall Habitat. The likelihood of a large spill contacting polar bear fall habitat would be greatest if a large spill occurred from the proposed LDPI during winter (up to a 71% chance of contacting 1 cell within 360 days). For each location and season, the chance of a large spill contacting more than one individual cell never exceeds 15%. While a large spill during winter from the proposed LDPI would be the most likely of locations and seasons to contact fall habitat, a spill during summer has the potential to contact the largest amount of polar bear fall habitat (up to 99 cells), because oil disperses more quickly during the warmer temperatures and open-waters characteristic of summer months. In general, a large spill from the proposed subsea pipeline would have slightly less potential to impact polar bear fall habitat than a spill from the proposed LDPI.

Winter Habitat. The likelihood of a large spill contacting polar bear winter habitat would be essentially the same regardless of the spill's timing or source. For each location and season, the chance of a large spill contacting one or more cells never exceeds 3%.

Spring Habitat. For all locations and seasons, the chance that a large spill would contact of polar bear spring habitat is <0.5%.

Chukchi and Bering Seas. Similarly, the USFWS used polar bear movement data from female polar bears collared in the southeastern Chukchi Sea and in Kotzebue Sound to delineate important polar bear habitat in winter and spring. These polygons represent all of the areas that had a >75% chance of use during two or more years of the study (Figure 4.3.4-14). These seasonal areas were analyzed as polygons in the OSRA model. Due to the large size of the winter and summer polygons, a gridded overlay methodology was used to assess whether any portion of each polygon was contacted by a large spill from the proposed LDPI or pipeline. Table 4.3.4-14 shows the percent chance of contact and is further analyzed below.

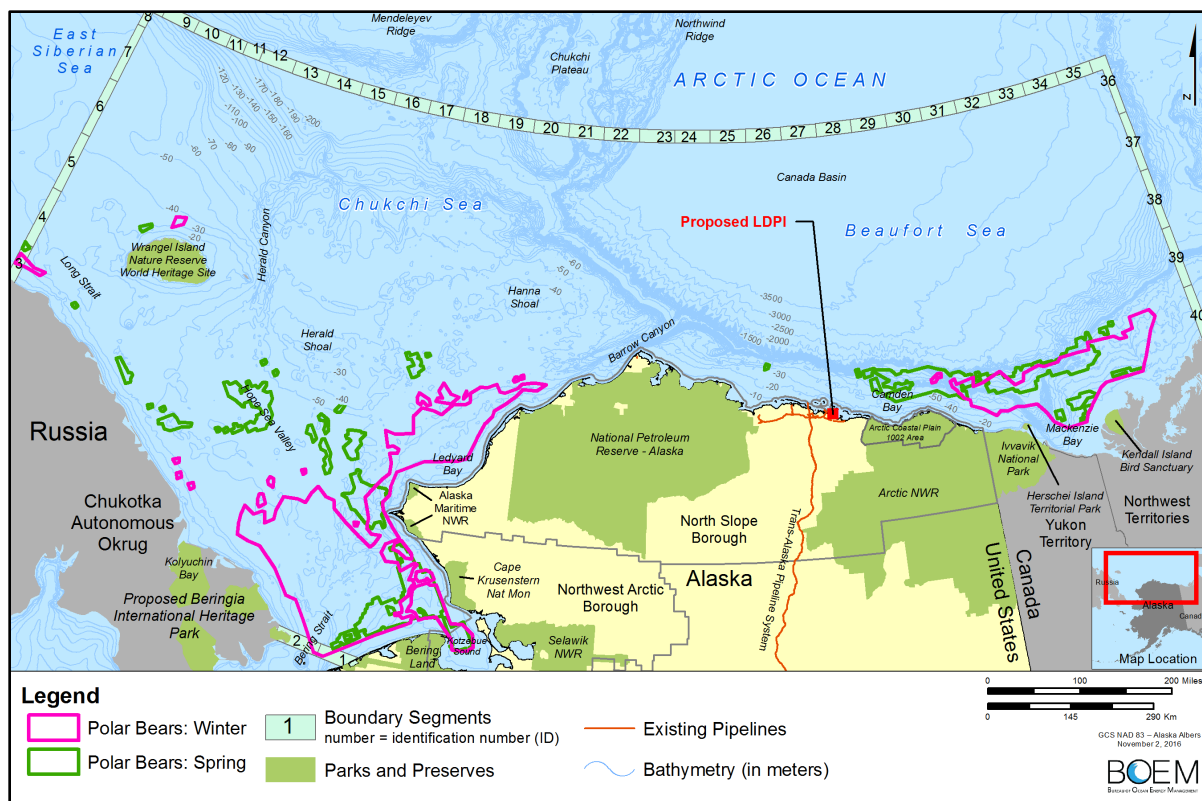

Figure 4.3.4-15. Chukchi and Bering Sea Polar Bear Habitat by Season. Based on actual collared female polar bears from the Chukchi /Bering Sea population. Source: USFWS, 2013 a, b in USDOJ, BOEM, 2015.

Table 4.3.4-18. USFWS Polar Bear Spring Habitat¹ Grid Cells and Chance of Oil Contact. (537 Cells).

Spill Source	Season	Days	<0.5% of Grid Cells Contacted	Total Grid Cells Contacted	Percent Chance of Contact to Habitat	Percent Chance of ≥2 Habitat Cells Contacted	>99.5% of Grid Cells Contacted
LI	Summer	3	537	<0.5	<0.5%	<0.5	<0.5
LI	Summer	30	505	32	1-2%	1-2%	<0.5
LI	Summer	360	494	43	1-3%	1-2%	<0.5
LI	Winter	3	537	<0.5	<0.5%	<0.5	<0.5
LI	Winter	30	513	24	1-2%	1-2%	<0.5
LI	Winter	360	490	47	1-2%	1-2%	<0.5
PL	Summer	3	537	<0.5	<0.5%	<0.5	<0.5
PL	Summer	30	523	14	1-2%	1%	<0.5
PL	Summer	360	505	32	1-2%	1%	<0.5
PL	Winter	3	537	<0.5	<0.5	<0.5	<0.5
PL	Winter	30	524	13	1-2%	1%	<0.5
PL	Winter	360	514	23	1-2%	1-2%	<0.5

Notes: Table indicates the number of grid cells within the polar bear habitat by season and the percent chance of contact from launch points within 3, 30 or 360 days. Chukchi and Bering Sea spring and winter polar bear habitat. USFWS et al. (2013a, b) in USDOJ, BOEM, 2015.

Table 4.3.4-19. USFWS Polar Bear Winter Habitat¹ Grid Cells and Chance of Oil Contact.

Spill Source	Season	Days	<0.5% of Grid Cells Contacted	Total Grid Cells Contacted	Percent Chance of Contact to Habitat	Percent Chance of ≥2 Habitat Cells Contacted	>99.5% of Grid Cells Contacted
LI	Summer	3	915	<0.5	<0.5%	<0.5	<0.5
LI	Summer	30	915	<0.5	<0.5%	<0.5	<0.5
LI	Summer	360	915	<0.5	<0.5%	<0.5	<0.5

Spill Source	Season	Days	<0.5% of Grid Cells Contacted	Total Grid Cells Contacted	Percent Chance of Contact to Habitat	Percent Chance of ≥ 2 Habitat Cells Contacted	>99.5% of Grid Cells Contacted
LI	Winter	3	915	<0.5	<0.5%	<0.5	<0.5
LI	Winter	30	915	<0.5	<0.5%	<0.5	<0.5
LI	Winter	360	912	3	1%	1%	<0.5
PL	Summer	3	915	<0.5	<0.5%	<0.5	<0.5
PL	Summer	30	915	<0.5	<0.5%	<0.5	<0.5
PL	Summer	360	915	<0.5	<0.5%	<0.5	<0.5
PL	Winter	3	915	<0.5	<0.5%	<0.5	<0.5
PL	Winter	30	915	<0.5	<0.5%	<0.5	<0.5
PL	Winter	360	915	<0.5	<0.5%	<0.5	<0.5

Notes: Table indicates the number of grid cells within the polar bear habitat by season and the percent chance of contact from launch points within 3, 30 or 360 days.

Chukchi and Bering Sea spring and winter polar bear habitat. USFWS et al. (2013a, b) in USDOI, BOEM, 2015.

Because both spring and winter polar bear habitat are not in immediate proximity to the proposed LDPI or pipeline and are outside of the barrier islands, which would contain some of the spill, the chance of a large spill from either of these source points contacting the habitats within 360 days is $\leq 2\%$ (Tables 4.3.4-14 and 4.3.4-15). A large spill during winter or summer is less likely to contact winter habitat than spring because winter habitat is farther from Foggy Island Bay (Figure 4.3.4-12). A winter spill is less likely to contact polar bear habitat than a summer spill because ice-cover would inhibit oil movement and dispersion.

Oil Spill Response

The conditional or combined probabilities do not consider the effectiveness of spill response activities to mitigate large spills which could range from highly effective under ideal conditions to largely ineffective depending upon the specific circumstance. An oil-spill response plan would be required prior to exploration or development and production activities. Oil spill response can cause disturbance, and the use of dispersants could harm marine mammals or their prey.

Oil spill response commencement time could vary depending on the location of the spill. Oil spill response equipment is cached in Deadhorse and in Utqiagvik, about 150 mi (241 km) west of Deadhorse. Oil spill response personnel would be expected to work with USFWS on walrus and polar bear management activities in the event of a spill and to work with NMFS on the management of other marine mammals present in the area.

During oil spill response activities, oiled carcasses would be collected when feasible, which could lessen the risk of polar bears ingesting oiled prey items. In some circumstances, oiled seals or seal carcasses floating in broken ice and in open leads would be very difficult to locate and recover. Removal of all types of oiled carcasses (birds, seals, fish, and other mammals) is an important primary oil spill response activity. This removes a source of secondary poisoning to scavengers and predators.

Hazing may be very effective in the case of small spills or in relatively discrete areas. Most marine mammals would be likely to avoid the high level of activity associated with cleanup activities. Polar bears may be curious and may approach personnel who are on shore or in vessel. Wildlife response activities could involve hazing bears away from an area; or capturing and transporting an oiled bear for cleaning and treatment though it is unlikely that an oiled bear would survive.

In general, cleanup activities could result in short or long-term displacement of polar bears and their prey from preferred habitats and increased human interactions and disturbance. Conversely, cleanup activities would likely decrease the likelihood that marine mammals may come into contact with oil by displacing them from oiled areas. These would not produce population-level impacts but could

affect polar bears in the immediate vicinity; therefore oil spill response would have minor impacts to polar bears.

Conclusion

The assessment of effects to polar bears from the Proposed Action includes the mitigation measures for marine mammals included in Appendix C (Sections C-1 to C-3), which reduce the likelihood of disturbance, displacement, and physical harm of polar bears by requiring minimum approach distances, pre-activity maternal den surveys, and a site-specific human-polar bear interaction plan. Implementation of these mitigation measures, in particular pre-activity den detection surveys, would reduce the level of impacts from the Proposed Action to minor.

Additional Proposed Mitigation

Periodically polar bear maternal dens go undetected during pre-activity den surveys and are discovered during activities (e.g., ice road use, drilling operations). Typically, mitigation requires that, upon discovery of the den, all activity within a 1-mile radius cease and USFWS be contacted to assess and provide guidance to the operator. Conducting activity cessation drills, where reasonably feasible, would increase workers' ability to swiftly and properly execute den discovery protocols. Such mitigation (specifically conducting drills to practice polar bear den ice road closure protocols) was recommended by USFWS during ESA Section 7 consultation for ExxonMobil's Point Thomson Project, which lies east of the Proposed Action on the U.S. Beaufort Sea coast (USDOJ, USFWS, 2012).

4.3.4.6.2. Alternative 2 – No Action

Under Alternative 2, the No Action Alternative, the proposed development and production activities would not be approved, and there would be negligible levels of effect to polar bears (Table 4.3.4-16).

4.3.4.6.3. Alternative 3 –proposed LDPI Relocation

Alternative 3 would relocate the proposed LDPI to one of two locations. Alternative 3A would place the proposed LDPI approximately 1 mi east of the Proposed Action site; Alternative 3B would place the proposed LDPI approximately 1.5 mi southwest of the Proposed Action site (Section 2.2.4). The ways in which aspects of the Proposed Action would be affected in some cases differ between Alternative 3A and Alternative 3B; therefore each option is discussed separately in comparison with the Proposed Action.

Alternative 3A: Relocate LDPI Approximately One Mile to the East

Under Alternative 3A, the proposed LDPI would be relocated approximately 1 mi east of the Proposed Action site. As a result, most ice road routes would differ from those anticipated under the Proposed Action. In addition, lengths would differ: The ice road from the mine site to the proposed LDPI location would be shorter, the ice roads from the proposed LDPI to the Badami tie-in, and from the proposed LDPI to Endicott SDI would be longer. Because the Alternative 3A site is in deeper water, a larger quantity of gravel and 7-10 days of additional construction days would be needed, resulting in a greater amount of ice road traffic during proposed LDPI construction, and a greater amount of activity at the mine site. The mine site footprint may be larger (unless deeper extraction from the existing footprint would meet gravel needs). Because the construction period would be extended, it is possible that proposed LDPI slope protection installation activities could extend farther into fall.

Since the Badami tie-in point would not change, the pipeline route would be longer and approximately 1 mi closer to the Kadleroshilik River Delta, an area of higher density potential denning critical habitat (Figure 3.2.4-15). The additional length of the pipeline would necessitate 8% more time to complete installation.

Because the Alternative 3A site is in deeper water and farther from the reservoir, the length of the wells would increase and additional time (approximately 70-80 days vs. 45 days) would be required to complete the wells. This would increase the length of time during which a large personnel population would be present on the LDPI.

During production operations there could be an increased need for aerial pipeline surveys and summer ancillary activities because the pipeline route would traverse the 100% overflow probability boundary (increasing the potential for strudel scours effects to the pipeline).

Decommissioning activities would be the same but could extend over a longer period of time because of the longer pipeline and potentially larger mine footprint.

Overall, Alternative 3A would have a comparably greater potential for disturbance and temporary displacement of polar bears from ice road and aircraft traffic and greater potential for human-bear interactions during the relatively longer construction and drilling periods and decommissioning activities. Long-term impacts to habitat could be greater if the gravel mine footprint is increased. In addition, the proximity of the pipeline to the Kadleroshilik River Delta likely would increase potential adverse effects to denning bears and the suitability of potential denning critical habitat at that location (Table 4.3.4-16).

While there increased potential for impacts to polar bears from Alternative 3A, impacts would not rise to the threshold of producing population-level impacts. Therefore the level of impacts from Alternative 3A would not differ from that described for the Proposed Action.

Alternative 3B: Relocate LDPI Approximately 1.5 Miles to the Southwest

Under Alternative 3B, the proposed LDPI would be relocated approximately 1.5 mi southwest of the Proposed Action site. As with Alternative 3A, most ice road routes and lengths would differ from those anticipated under the Proposed Action: The ice road from the mine site to the proposed LDPI location and the ice roads from the proposed LDPI to the Badami tie-in would have different trajectories; the ice road from the proposed LDPI to Endicott SDI the ice road for pipeline installation would both be shorter. Because the Alternative 3B site is in shallower water, a small quantity of gravel and 4-6 fewer days of construction days would be needed, resulting in a less ice road traffic during proposed LDPI construction, and a less activity at the mine site. The mine site footprint may be smaller and/or shallower.

Since the Badami tie-in point would not change, the pipeline route would be shorter and the pipeline would take 10-14 fewer days to install.

Because of the increased distance from the reservoir, the length of the wells would increase and additional time (approximately 120 days vs. 45 days) would be required to complete the wells. This would increase the length of time during which a large personnel population would be present on the proposed LDPI.

Decommissioning activities would be the same but could occur over a shorter period of time because of the shorter pipeline and potentially smaller mine footprint.

Overall, Alternative 3B would have comparably less potential for disturbance and displacement of polar bears from ice road and aircraft traffic. There would be less potential for human-polar bear interactions during ice road construction, mine site development, proposed LDPI construction and pipeline installation but greater potential for such interactions during the longer drilling operations phase. Because the footprint of the ice roads, mine site, and pipeline is smaller, less critical habitat would be altered (Table 4.3.4-16).

Conclusion

While there is slightly decreased potential for impacts to polar bears from Alternative 3B, impacts to individuals could still be long-lasting and wide-spread throughout the local stock's range. Therefore the level of impacts from Alternative 3A would remain the same as that described for the Proposed Action.

4.3.4.6.4. Alternative 4 – Alternate Processing Locations

Alternative 4 would relocate the processing facilities from the proposed LDPI to an onshore location (Section 2.2.5). Two options exist for onshore processing: use of an existing facility and construction and use of a new facility. The ways in which aspects of the Proposed Action would be affected differ between Alternative 4A and Alternative 4B, therefore each option is discussed separately in comparison with the Proposed Action.

Alternative 4A: Relocate Oil and Gas Processing to Endicott

Under Alternative 4A, processing would be relocated to Endicott. Because processing equipment would no longer be on the LDPI, the proposed LDPI surface footprint would be reduced to 5.4 acres and construction of the smaller proposed LDPI would take 18-20 fewer days. The mine site footprint would be smaller, and duration of mine site development shorter, because less gravel would be needed.

The pipeline would route from the proposed LDPI to Endicott; no onshore pipeline activities would occur beyond installation, monitoring, and maintenance at the connection to the Endicott SDI. The pipeline itself would be 2.8 mi longer, for a total length of 8.4 mi. The 3-phase flowline would be 14 inches in diameter instead of 12 inches and would require 50% more construction materials. As a result, pipeline installation would take 40-50 additional days, and would have a larger footprint.

Activities associated with facilities installation (e.g., marine vessel traffic) would be reduced because fewer modules would be needed on the island. Human presence during production would be concentrated at Endicott, a site of existing anthropogenic activity; fewer personnel would be needed on the proposed LDPI during production operations. As a result, fewer crew transfers would be required, and less waste would be generated at the LDPI.

Decommissioning would require less time and activity because this alternative would reduce the amount of infrastructure to be removed.

Overall, Alternative 4A would have comparatively less potential for disturbance and displacement of polar bears during mine site development, proposed LDPI construction, facilities installation, production operations, and decommissioning because less new infrastructure would need to be installed. Potential for disturbance and displacement from pipeline installation would be greater because of the longer amount of time needed to place the flowline; however, the additional time constitutes a very small fraction of the life of the Proposed Action. The potential for human-polar bear interactions would be less during all phases of the Proposed Action except pipeline installation, since the installation timeline would be extended. The loss or alteration of polar bear critical habitat from Alternative 4A would be less than under the Proposed Action because the footprint of the mine site and proposed LDPI would be smaller and existing facilities (which are not considered polar bear critical habitat) would be used (Table 4.3.5-16).

Because the potential effects of Alternative 4A are less than the Proposed Action and because Alternative 4A involves very little long-term impact to undeveloped polar bear terrestrial habitat, which is increasingly important in light of trends in sea ice loss, the overall level of impacts from Alternative 4A would be minor.

Alternative 4B: Relocate Oil and Gas Processing to a New Onshore Facility

Under Alternative 4B, a new onshore processing facility would be constructed near the proposed Badami pipeline tie-in. Construction would include a new gravel production pad on which processing equipment and support facilities (e.g., personnel housing) would be located, and either an all-season gravel road or boat dock to allow facilities access during shoulder seasons and ice-free months. The onshore facilities would require additional personnel during all phases of the Proposed Action. While the new pad would require gravel, the reduction in proposed LDPI surface footprint would result in an overall decrease in the amount of gravel needed for the Proposed Action. As a result, the mine site footprint would be smaller, and duration of mine site development shorter. In addition, proposed LDPI construction would decrease by 15-20 days.

The pipeline route would follow that proposed for the Proposed Action; however, the larger diameter of the flowline would result in a larger footprint and an additional 10-15 days for installation.

Facilities installation activities at the proposed LDPI would decrease because less equipment would be needed offshore. However, throughout facilities construction and production operations, a greater amount of traffic and anthropogenic activity would occur onshore.

Decommissioning activities would be dependent on whether the onshore infrastructure could be used for other oil and gas projects or if all surface structures would be removed. If onshore infrastructure were to remain, decommissioning would focus on the proposed LDPI and pipeline and would require less time and activity because less infrastructure would need to be removed. If all surface structures were to be removed, the time needed to complete decommissioning would be extended to allow for removal of structures both on and offshore.

Overall, Alternative 4B would have comparatively greater potential for impacts to polar bears because of the installation and continuous use of onshore facilities in an area of polar bear critical habitat. While the proposed LDPI and gravel mine footprints would be smaller, the onshore gravel pad and supporting gravel roads and/or boat dock would result in the long-term loss of increasingly important terrestrial habitat, including suitable denning critical habitat. Potential for disturbance and displacement of polar bears, and the likelihood of human-polar bear interactions, would be greater because a larger proportion of activities would occur onshore and human presence would be continuous (Table 4.3.4-16).

While there increased potential for impacts to polar bears from Alternative 4B, impacts would not rise to the threshold of producing population-level impacts. Therefore the overall level of impacts from Alternative 4B would not differ from that described for the Proposed Action.

4.3.4.6.5. Alternative 5 – Alternate Gravel Sources

Alternative 5 would relocate the gravel mine to one of three locations (Section 2.2.6), each of which would differ in potential impacts to polar bears. The types and potential for impacts during pipeline installation, facilities construction, drilling and production operations, and decommissioning are not expected to differ between the Proposed Action and Alternative 5, with the exception of an extended proposed LDPI construction window if the Duck Island Mine site is used.

Alternative 5A: East Kadleroshilik River Mine Site #2

This site lies approximately 2 mi inland from the coast and 7 mi from the proposed LDPI, placing it farther from the polar bear shoreline transit corridor than the Proposed Action mine site. Placement further from the shore could slightly reduce potential disturbance, displacement, and human-bear interactions compared to the Proposed Action. Longer ice roads, and possible different ice road routes, would be required to transport gravel during proposed LDPI construction and likely to support pipeline installation. Temporary critical habitat loss from mine site support facilities would occur but would not persist any longer than under the Proposed Action.

Overall, East Kadleroshilik River mine site #2 would have comparably greater potential for disturbance and displacement of polar bears during the ice road construction and use because of the longer roads. Long-term impacts to critical habitat from the mine site itself could be slightly lessened because it is farther from the high-traffic polar bear transit area; however the need for longer ice roads would temporarily alter a greater amount of potential habitat. The potential for human-polar bear interactions is not expected to differ notably from the Proposed Action (Table 4.3.4-16).

While there increased potential for impacts to polar bears from use of East Kadleroshilik River mine site #2, impacts would not rise to the threshold of producing population-level impacts. Therefore the level of impacts from this option would not differ from that described for the Proposed Action.

Alternative 5B: East Kadleroshilik River Mine Site #3

This site lies 15 mi from the proposed LDPI. This mine site would be at greater risk for erosion and would be closer to the polar bear shoreline transit corridor than the Proposed Action mine site. Longer ice roads, and possible different ice road routes, would be required to transport gravel during proposed LDPI construction and likely to support pipeline installation. Temporary habitat loss from mine site support facilities would occur but would not persist any longer than under the Proposed Action.

Overall, East Kadleroshilik River mine site #3 could have comparably greater potential for disturbance and displacement of polar bears during the ice road construction and use because of the longer roads and proximity to polar bear denning critical habitat. Additionally, potential impacts to polar bears traveling along the shoreline would be increased due to the site's proximity to the coast. Impacts to habitat could be increased. The potential for human-polar bear interactions is not expected to differ notably from the Proposed Action (Table 4.3.4-16).

While there is increased potential for impacts to polar bears from use of East Kadleroshilik River mine site #3, impacts would not rise to the threshold of producing population-level impacts. Therefore the level of impacts from this option would not differ from that described for the Proposed Action.

Alternative 5C: Duck Island Mine Site

The Duck Island mine site is a flooded but not yet remediated site that is a 42-mi round-trip from the proposed LDPI. It is located near the industrial areas of Deadhorse and the North Slope Eastern Operating Area. Gravel would be transported on an established road system to the established LDPI ice road network.

Because of the distance between the mine site and the LDPI, proposed LDPI construction likely would be extended over two years. No polar bear critical habitat would be lost or altered from mine site or support facilities because its location is outside of polar bear critical habitat designation.

Overall, the Duck Island site could have comparably less potential for disturbance and displacement of polar bears and human-polar bear interactions during the ice road construction and use because of the distance from the coast and its proximity to the industrial areas of Deadhorse and the North Slope Eastern operating Area. Likewise, potential for disturbance and displacement of polar bears and human-polar bear interactions during mine site development would be extended over two years. Impact to critical habitat would be less because gravel would be transported over an established road system and no habitat loss would be expected.

The potential for impacts to polar bears from use of the Duck Island mine site would be decreased from those described for the Proposed Action and impacts would not rise to the threshold of producing population-level impacts.

Table 4.3.4-20. Alternatives 2-5 Gravel Mine Location and Impacts to Polar Bears Compared to The Proposed Action.

Alternative	Disturbance or Displacement	Habitat Loss or Alteration	Human-Polar Bear Interactions	Comparative Level of Impacts
2: No Action	less (none)	less (none)	less (none)	less (none)
3A: Proposed LDPI Relocation East	greater	greater	greater	same
3B: Proposed LDPI Relocation Southwest	less	less	less to more (phase-dependent)	same
4A: Onshore Processing at Existing Facility	less	less	less	less
4B: Onshore Processing at New Facility	greater	greater	greater	same
5A: East Kad River Mine Site #2	greater	greater	same	same
5B: East Kad River Mine Site #3	greater	same	same	same
5C: Duck Island Mine Site	less	less	less	less

4.3.4.7. Overall Conclusions for Marine Mammals

The Proposed Action has many similarities to other previous projects in the Beaufort Sea, such as Endicott, Northstar, Oooguruk, and Nikiachuk. To date such projects have not produced any documented changes in marine mammal populations or regional distributions, nor have they produced any chronic behavioral responses. Due to advances in technology, planning, and work experience in the Arctic, and due to the location of the Proposed Action, the overall effects from the proposed action should be less than that of the Northstar Project, and slightly greater than the Oooguruk or Nikiachuk Projects.

4.3.5. Terrestrial Mammals

Caribou, muskoxen, brown bear, and Arctic fox, and Arctic ground squirrel are the terrestrial mammals most likely to be affected by the Liberty Development. The following analyses consider potential impacts to each of the key mammal species described, and provides an overall conclusion for terrestrial mammals as a group.

Typical oil and gas development impacts related to habitat, disturbance, mortality, and productivity of terrestrial mammals are described in the Point Thomson Final EIS (USACE, 2012a, Section 5.10); the 2007 Liberty DPP EA (USDOJ, MMS, 2007a; BPXA, 2007, Sections 3.1.9; 3.2.6; and 3.3.9); and the 2002 Liberty DPP FEIS (USDOJ, MMS, 2002, Section III.A.1 and III.A.2.d).

Impacts to terrestrial mammals and their dens, burrows, foraging, insect-relief areas, and resting habitats could come from:

- Aircraft Operations
- Vehicle Operations (including heavy equipment)
- Gravel Mining
- Onshore Ice Roads
- Wildlife-Personnel Interactions
- Habitat Alteration
- Pipeline Construction
- Oil Spills

Aircraft Operations

Aircraft traffic in support of OCS activities includes helicopter flights for personnel transport and fixed-wing aircraft engaged in monitoring activities. Up to two helicopter trips per day could occur during some stages of the Proposed Action (Hilcorp, 2015, Appendix A).

Aircraft flying under 1,000 ft AGL have been known to frighten caribou and muskoxen, forcing herds and individuals to scatter, separating cows from calves, and possibly causing individuals to injure themselves. While grizzly bears do not aggregate, they too have been known to panic when approached by low-flying aircraft. In these instances a grizzly tends to seek out the nearest cover, such as willows, so that it may hide until the perceived threat passes. Fleeing female grizzlies could become separated from their cubs. As with caribou and muskoxen, such a separation from their parent could result in offspring mortalities.

Helicopters

Most helicopter use in support of OCS activities is for ferrying personnel and equipment to OCS operations. Helicopter flights are typically kept at a minimum altitude of 1,500 feet Above Ground Level (AGL) to mitigate impacts to marine mammals unless safety requirements necessitate lower altitudes (NMFS, 2013).

Helicopters could access the proposed LDPI year-round. Helicopter traffic would occur between Deadhorse or Prudhoe Bay and the proposed LDPI (Hilcorp, 2015, Appendix A).

Estimated traffic levels could include up to two helicopter round-trips per day during construction, drilling and operations (Hilcorp, 2015, Appendix A). Disturbances from aircraft operations may lead to flight reactions, decreased foraging, and abandonment of offspring. Such effects could ultimately result in increased energetic costs among affected animals, decreased energy intake, and potential injuries or mortalities.

Most air traffic from Deadhorse to the proposed LDPI would pass over the middle of the Sagavanirktok River Delta. The potential for disturbance to animals using the delta would be present during all seasons, but would be greatest during spring and summer because more terrestrial mammals are present or active in the Proposed Action Area at that time of year.

The Augusta Westland 139 is the helicopter model expected to be used for the Proposed Action (2015 Liberty DPP). According to Greene and Moore (1995:102-110), helicopters are capable of producing tones mostly in the 68 to 102 Hz range at noise levels up to 151 dB re 1 μ Pa-meter (m) at the source. Additionally, they radiate more sound forward than backwards, which means noise levels would be audible at greater distances ahead of the aircraft than to its rear.

Helicopter noise is generally audible for tens of seconds as a helicopter is approaching or departing an area. Generally, terrestrial mammal responses vary depending on aircraft flight altitude and received sound levels, and range from no reaction from habituated animals to violent, injurious escape responses.

Fixed-Wing Aircraft.

The purpose of fixed wing operations associated with the Proposed Action would likely be to assess marine mammal habitat use, distribution, and movement. Fixed wing aircraft may also be used to monitor behavior before, during, and after seismic surveys and drilling operations occur. Monitoring surveys are typically conducted with aircraft flying above 1,500 ft AGL unless safety becomes an issue. Greene and Moore (1995:102-105) explained fixed wing aircraft typically used in offshore activities were capable of producing tones mostly in the 68 to 102 Hz range and at noise levels up to 162 dB re 1 μ Pa-m at the source. The DHC-6 Twin Otter slated for use in the Proposed Action has source levels of up to 150 dB re 1 μ Pa (CDPST, 2000). Though the noise levels of aircraft are insufficient to create physiological effects among terrestrial mammals, behavioral responses that include avoidance, flight responses, etc. are possible.

Vehicle Operations

Vehicular activity in the Proposed Action Area would create temporary disturbances along existing and potential transportation corridors. Potential summer construction activity at the Endicott Secondary Drilling Island (SDI) would create an increased level of traffic along the Endicott Road during gravel hauling (Hilcorp, 2015, Appendix A). Construction of ice roads across tundra habitats would likely result in some small mammal mortality, especially if ice roads are constructed across burrows with hibernating Arctic ground squirrels. Darkness limits human vision during the winter construction seasons, and vehicle collisions with terrestrial mammals may occur. The most likely cause of Proposed Action-related mortality to terrestrial mammals would be vehicle collisions on gravel and ice roads (Hilcorp, 2015, Appendix A).

Caribou, muskoxen, grizzly bears, and most furbearers are sensitive to the use of vehicles in their surroundings. As with aircraft, vehicles have the tendency to frighten some terrestrial mammals into a panic (Stokowski and LaPoint, 2000). Once panicked, some individuals may injure themselves trying to escape, or become separated from offspring or a herd. An individual animal may or may not show signs of sub-lethal effects of vehicular disturbance that result in an overall decrease in individual animal's fitness.

Heavy Equipment

During construction of the ice roads leading to the Northstar project several bulldozers and rollagons were used simultaneously. The noise levels from these various types of heavy equipment were later analyzed, and Greene et al. (2008) determined ice road construction was one of the quieter activities occurring during the construction of the Northstar Project (Table 4.3.6-1). Greene et al. (2008) found ice road construction (bulldozers, trucks, Ditch Witches, augers, pumps, etc.) was collectively the least noisy activity that occurred with the Northstar Project during winter.

Table 4.3.5-1. Northstar Project Heavy Equipment Noise.

Sound Source	Broadband SPL at 100 m (dB re 20 µPa)	Frequency Bandwidth of produced noise ≥100 dB re 20 µPa
Bulldozer	114.2	31.5 Hz–125 Hz
Augering	103.3	None
Pumping	108.1	500 Hz–1 kHz
Ditch Witch	122	<5 Hz - 3.15 kHz
Trucks	123.2	<5 Hz–500 Hz
Backhoe	124.8	<5 Hz–1.2 kHz
Vibrahammer, sheet-driving	142.9	23 Hz–25 Hz
Sheet Pile-driving	132	5 Hz–55 Hz
*Background Noise	78–110	20 Hz–5 kHz

Note: * Highly variable due to changing environmental variables.

Source: Greene et al., 2008; Blackwell, Lawson, and Williams, 2004.

Gravel Mining

The proposed gravel mining would occur during winter. Harding (1976) found 78% of the grizzly bear den sites in his study in the Canadian Northwest Territory were situated in steep stream or lake banks, and 13% were located in slumped lake or channel banks, sites that are typically used to mine gravel. Most of the dens were located under clumps of alder or willow. McLoughlin, Cluff, and Messier (2002) found grizzlies in the central Arctic excavated dens under dwarf birch more than any other plant species. Their conclusions agree with those of previous studies (Harding 1976) in that the preferred substrate for grizzly dens is sandy soils with clay/silt/cobble content, and a slope of about 25%. They went on to suggest that gravel could be too loose for structurally sound dens.

In the unlikely case where a grizzly bear has dened in a gravel site, mining activities during the October thru April timeframe could have the potential to awaken, drive away, or cause mortality to grizzlies.

Onshore Ice Roads

During the winter and spring seasons, the nearshore waters of Foggy Island Bay are covered in natural ice sheets up to 6 feet thick. In association with this offshore ice, onshore ice roads would be constructed and used by vehicles and heavy equipment. Onshore ice roads would be constructed using Arctic best management practices (BMPs), to allow trucks to move construction materials to the proposed LDPI Site, and to access eastern developments.

Construction of ice roads across tundra habitats may result in some small mammal mortality, especially if ice roads are constructed across burrows with hibernating Arctic ground squirrels. Because darkness limits human vision during the winter construction seasons, increased vehicle collisions with terrestrial mammals may occur during this time of year. The most likely cause of Proposed Action-related mortalities to terrestrial mammals would be vehicle collisions on gravel and ice roads (Hilcorp, 2015, Appendix A).

Wildlife-Human Interactions

Causes of animal aggression toward humans are often related to food-conditioning of bears and foxes. Also, many foxes on the North Slope are carriers of the rabies virus. These circumstances can create increases in aggressive behavior toward humans. Interactions that might occur between humans and animals include unintentional harassment or disturbance of parturient (preparing to give birth) females, and isolation of young animals from their mothers. A few animals could be killed because they behave aggressively towards humans, or because they display defensive responses to the actions or presence of humans.

Because some animals can become a threat to human safety, they may be killed to defend human life. For instance, five red foxes and an ermine were killed because of aggression towards people between 2010 and 2012 (Streever and Cargill Bishop 2013). While such incidents are uncommon, a few can be expected during outdoor work in all phases of the Proposed Action (Hilcorp, 2015, Appendix A).

Habitat Alteration

The most important impacts relating to terrestrial mammal habitat alteration would occur in the onshore pipeline corridor. Such changes could block migrations and movements of some species, disrupt habitat uses during critical life stages, and remove potential foraging opportunities in affected areas.

Proposed Action construction and operations would likely result in moderate short-term disturbance, minor to moderate long-term loss of about 24 acres of tundra habitat, and potential minor alteration of 5 acres of habitat (Hilcorp, 2015, Appendix A).

Pipeline Construction

The onshore pipeline landing would be trenched from the shoreline inland for about 300 feet before transitioning to an aboveground pipeline constructed at least 7 feet above the ground surface (Hilcorp, 2015, Appendix A) except where the pipeline cross the Badami ice road. The pipeline landing trench would require long-term annual onsite monitoring for erosion that would create disturbance to terrestrial mammals.

Accidental Oil Spills

In the event of an oil spill, some terrestrial mammals may be exposed to oil along the coastline. If such an event occurred, an animal's fur could become oiled, compromising its insulative value, potentially decreasing the animal's health or ability to thermoregulate. Other potential effects could occur through prolonged inhalation of oil slick fumes, leading to the development of lesions on the lining of the lungs or eye irritation. Terrestrial mammals could also ingest contaminated food items which could lead to kidney or liver damage.

Oil Spills are described and defined in Section 4.1.1.2.

Potential physiological effects that could reduce terrestrial mammal fitness include:

- Irritation, inflammation, or necrosis of skin
- Chemical burns of skin, eyes, mucous membranes
- Inhalation of toxic fumes with potential short- and long-term respiratory effects (e.g., inflammation, emphysema, infection, pneumonia)
- Partial or extensive coating of pelts with oil which could reduce insulation and result in hypothermia and/or ingestion of oil during grooming; either could result in mortalities
- Ingestion of oil (and dispersants) directly, or via contaminated food, leading to inflammation, ulcers, bleeding, damage to liver, kidney, and brain tissues
- Absorption of oil or dispersants through the skin, damaging the liver and kidneys, causing anemia, suppressing the immune system, inducing reproductive failure, and in extreme cases killing an animal
- Extended travel and search time to locate alternative insect relief areas
- Increased foraging and travel time to obtain remaining resources leading to increased energetic costs
- Relocation of home ranges or increased competition at grazing areas due to direct mortality of food resources.
- Increased travel to unfamiliar areas to obtain forage that may be of lower quality, or has lower nutritive content.
- Decreases in diet diversity due to lower food availability, eventually leading to reduced overall health, with greatest impacts potentially occurring at times when energetic requirements are greatest
- Disturbance from beach cleanup crews, vessels and aircraft during spill response

Complications of the above could quickly lead to reduced fitness, injury and mortalities. In addition to immediate effects, mortalities and chronic sub-lethal effects could affect individual fitness, reproduction, prey availability and behavior, and lifespan of some individuals.

While caribou and muskoxen might accidentally consume oil by grazing on oiled plants, grizzlies and furbearers may ingest it by scavenging on an oiled carcass or by predating oiled animals. The potential effects to terrestrial mammals from ingesting crude oil could be lethal, based on studies where cattle were exposed to oil (Osweiler, 2016).

The severity of harm caused to terrestrial mammals by oil spills varies according to a number of factors, such as:

- **The amount of exposure of each animal to oil.** The greater the area an oil spill covers, the more difficult it becomes for animals to avoid the oil particles, and the greater the magnitude of exposure. Furthermore, as the time period over which oil is present increases, so too does the likelihood of exposure to the spill for individual animals.
- **The contact pathway for each animal exposed to oil.** The oil exposure pathway (ingestion, absorption, or inhalation) can influence the rate, and severity of the effects. Animals with varied diets could have fairly limited contact with oil via ingestion, since their diets are more flexible. Conversely animals such as muskoxen tend to show a good deal of habitat fidelity, and may readily not readily relocate to avoid contaminated foraging areas.
- **The physical state and health of individual animals.** The age and overall health of an animal would be a determining factor on the degree of harm caused from oil spill exposure. Individuals

with lower fitness could be impacted more than robust individuals in prime condition. Consequently, the young, old, injured, or diseased would most likely manifest adverse responses to spilled oil before young and healthy adults would (Ober, 2016).

The conditional and combined probabilities represent the probability of some portion of a large spill, released from LI (LDPI) or PL (LDPI to Badami pipeline), contacting ERAs, GLSs, or LSs. Only those ERAs or GLSs identified as having special importance for terrestrial mammals will be analyzed, and only those ERAs or GLSs having contact probabilities $\geq 5\%$ will be described in detail.

The use of $\geq 5\%$ as the delineation for subsequent analyses is based on the 95% confidence interval that is typically used in the sciences, and represents what would be deemed reasonably foreseeable. For the purpose of the species specific spill analyses, a probability value of $\leq 5\%$ indicates there is a $\geq 95\%$ probability the ERA or GLS would not be contacted by spill materials, while a probability value $\geq 5\%$ indicates there is a $< 95\%$ probability of no contact.

Oil slicks originating at the proposed LDPI or from a pipeline rupture should have limited effects on terrestrial mammals under most conditions. If a large spill were to wash ashore up to several thousand caribou could come in contact with the oil if they were aggregated into large herds such as when seeking insect relief areas along the coast. During fall, winter, and much of spring the likelihood of such large numbers of caribou would decrease to disappear entirely. In contrast, very few muskoxen, Arctic foxes, or grizzly bears should be oiled under such conditions because of low population densities, distribution across a large geographic area, or life cycle characteristics. Foxes and grizzly bears could be attracted to feed on caribou or marine mammal carcasses that succumb to the adverse effects of oil exposure.

Oil-Spill Response and Cleanup and Spill Drills

Summer cleanup tactics would involve placement of booms, transportation across and along shorelines, and removal of oil that could result in displacement of terrestrial mammals away from contaminated tundra and shorelines, reducing the likelihood of exposure. An oil spill could affect terrestrial mammals on tundra and at shorelines from scavenging carcasses washed ashore. Oiled carcasses could be scavenged by foxes and grizzly bears.

Ingestion of oil can result in lethal and sub-lethal effects to Arctic fox, such as changes in the liver and brain, bone marrow depletion, gastrointestinal tract ulcers, inflammation of lungs and nasal passages, and kidney failure (USDOJ, MMS, 1999).

Deflection boom and skimmers would be placed along the mainland shoreline, and vessel-based reconnaissance and skimming would continue during the following open-water season if oil were present. These activities may result in a few terrestrial mammals being displaced from the cleanup area, which would reduce their risk of exposure to spilled oil. Collectively, these measures would minimize the likelihood of oil reaching the shoreline, and minimal impacts to terrestrial mammals would be expected. A direct consequence of spill response activities may be displacement of terrestrial mammals from oiled areas until the cleanup process is complete. Activities that could affect terrestrial mammals include air traffic, vessels operating in nearshore areas, and the presence of people working to remove spilled oil. Vessel and aircraft traffic associated with an oil-spill response and cleanup may startle caribou, muskoxen, bears, or wolves.

It is likely some bears and other scavenging mammal species could be disturbed while feeding on carcasses, potentially creating bear-human conflicts. Cleanup activities such as beach cleaning may be performed with a high degree of success using newer technologies (Painter, 2011), particularly if substrate is silty or sandy or if there is a layer of permafrost near the substrate surface. However, other activities such as spill cleanup under ice or in areas of broken ice may be more problematic (NRC, 2014; PAME, 2014).

On-Ice Spill/Under-ice Rupture

During winter, an on-ice spill could occur; however, the proposed Liberty site occurs in an area of continuous shorefast ice which would prevent spilled oil or gas from entering the Beaufort Sea. Cleanup actions would include collecting all oil or gas from the spill, and processing spilled products or contaminated materials at appropriate facilities.

Small pipeline ruptures under shorefast ice could be difficult to detect, since there wouldn't be a loss in pipeline pressure sufficient to stop the pipeline. The spilled materials would be similar in some respects to naturally occurring oil and gas seeps found throughout the world's oceans, and would most likely have little to negligible levels of effect on marine mammals.

Large oil spills occurring under sea ice could create a loss of the static pressure within the ruptured pipeline, forcing a shutdown of that pipeline until the situation is remedied. Depending on the location of the spill materials could be flushed out into Stefansson Sound, or could rise to the bottom of the shorefast ice. During spring some of this oil would likely be transported through the ice to the top of the affected shorefast ice area via capillaries in ice. Some of that oil could be cleaned up using conventional methods until shorefast ice degrades and no longer safely permits cleanup activities. The oil remaining in the ice would subsequently break up with the ice and gradually disperse in chunks of ice into the Beaufort Sea. Occurrence of such oiled sea ice would most likely be dispersed over a broad area and the ensuing effects would be similar to those of small spills.

4.3.5.1. Species Specific Effects

4.3.5.1.1. Caribou

4.3.5.1.2. The Proposed Action

Aircraft Operations

Caribou often respond to aircraft noise with heightened alertness, nervousness, and flight responses. Under such circumstances, mothers could become separated from their young, individual animals could injure themselves, and energetic losses and other physiological changes could occur. Caribou are most sensitive to disturbance and displacement from preferred habitats early during the calving period. Helicopter over flights could but are unlikely to cross over traditional caribou calving concentrations between the Sagavanirktok and Canning rivers. No caribou are expected to use the Sagavanirktok River Delta area near the Endicott Road during calving as most calving locations occur east of this area. Cows and calves may move closer to the coast and the delta during post-calving in late June.

Caribou have been shown to exhibit panic or violent flight reactions to aircraft flying at elevations of 60 m (162 ft) or less, and strong escape responses (animals trotting or running from aircraft) to aircraft flying at 150-300 m (500-1,000 ft) (Calef, DeBock, and Lortie, 1976). These documented reactions of caribou were from aircraft that circled and repeatedly flew over caribou groups. Some of the aircraft traffic associated with exploration is likely to pass overhead of caribou once during any flight to or from the platforms; and the disturbance reactions of caribou are expected to have negligible levels of effect on caribou herd distribution and abundance.

Aircraft flying below 1,000 AGL could elicit flight/escape reactions from caribou that could lead to injuries, separation of parturient females from their offspring, and possibly lead to the abandonment of areas by some caribou. Some injuries or isolated mortalities from aircraft operations could occur, particularly among young caribou or weaker individuals, unmitigated aircraft use would have a moderate level of effects on caribou under most circumstances. If Proposed Action aircraft, helicopters especially, were to make low-altitude approaches to large aggregations of calving caribou in May and early June, large numbers of caribou calves could be separated from their dams and die

from starvation, predation, exposure, etc. Such incidents should be viewed as having a major level of effects on caribou because of the large number of mortalities that could occur.

Implementation of mitigation measures described in Appendix C such as maintaining minimum altitudes of 1,000 ft AGL, and avoiding flights over calving grounds between 1 May and 15 June, would reduce the actual and potential impacts from aircraft operations to a negligible level of effects.

Vehicle Operations

Increased summer traffic may lead to an increase in disturbance to caribou moving through the Sagavanirktok River Delta, and traffic increases to more than 15 vehicles or more per hour could result in delays or deflection of caribou groups crossing the Endicott Road (USACE, 2012a).

Construction of the pipeline tie-in pad and installation of the vertical structural members (VSMs) and aboveground portion of the pipeline would create onshore winter traffic. These activities could potentially cause short-term noise disturbance and displacement, or collisions with small numbers of caribou overwintering in the area.

No caribou are expected to use the Sagavanirktok River Delta area near the Endicott Road during calving (USACE, 2012a, Section 5.10), as most calving locations occur farther east. Cows and calves may move closer to the coast and the delta during post-calving in late June.

Caribou mortalities from vehicles occur sporadically in the North Slope oilfields (Streever et al. 2007; Streever and Cargill Bishop, 2013); suggesting vehicle-caribou collisions would be one of the most likely causes of mortalities among caribou stemming from the Proposed Action. For this reason there would be some mortalities associated with vehicle traffic along permanent roads, and perhaps some mortalities along ice roads, which raises the potential level of effects to moderate.

Vehicular movement may evoke an unconditioned response to perceived predation risk (Frid and Dill, 2002). Therefore, minimizing traffic, especially within calving areas during the calving period, would reduce the potential for negative impacts on caribou. To maximize efficacy, calving period-specific mitigation measures in established oil fields might be terminated or extended, based on the timing of spring snowmelt (Haskell et al., 2006).

No year-round roads are described in the Proposed Action, only ice roads; however ice roads would last into early June and some vehicle traffic would use existing roads. Consequently, vehicle traffic on onshore ice and permanent roads could affect caribou and their newborn calves in May and early June. Those effects would likely produce reactions among caribou out to a distance of up to 600 m during the insect relief periods (Murphy and Curatolo, 1987). Restricting the use of vehicles to the area immediately around camps and avoiding calving caribou or caribou aggregations by 600 m (0.37 mi) (Horejsi 1981) from mid-May to mid-June, and from mid-July to late-August would reduce impacts to negligible levels of effect.

Heavy Equipment

The noise and activity associated with heavy equipment operations could cause caribou to avoid using habitat in the vicinity of roads, pipelines, and gravel mines being constructed. The avoidance behavior should last only as long as the heavy equipment remains in operation; however, some heavy equipment can damage tundra vegetation such that several years can pass before the damaged areas recover to an ecological state usable by caribou. Such damage to the vegetation would be restricted to relatively small areas and would most likely not affect the presence or absence of caribou. Consequently, the temporary and non-lethal effects from heavy equipment on caribou would constitute a negligible level of effects.

Gravel Mining

The construction of pipelines and other onshore facilities on the North Slope necessitates the use of very large quantities (several million tons) of gravel. With the construction of roads and gravel pads for facility-building sites, small areas of tundra vegetation are excavated at the mine site, allowing industry to access the gravel resources. The proposed gravel site occurs in calving areas (15 May–15 June) and insect relief (July–August) areas used by Central Arctic Herd (CAH) caribou.

Most caribou migrate south of the Proposed Action Area during winter when gravel would be mined, but small bands could persist in the area during winter mining activities. Such disturbances would likely persist for the duration of gravel mining activity.

The most likely response from caribou to active gravel mining would be avoidance by around 2.4 km while gravel extraction occurs (Boulanger et al. 2012). Caribou would be unlikely to be adversely affected when no gravel extraction occurs. The temporary, and non-lethal, non-injurious impacts of gravel mining on caribou would collectively amount to a negligible level of effects.

Onshore Ice Roads

Research suggests caribou in the U.S. Arctic generally avoid areas within 4 km of oil-field roads after road construction is completed (Cameron et al., 1992; Joly, Nellemann, and Vistness, 2006). However, some have suggested avoidance is not guaranteed, and caribou may habituate to infrastructure and human activity (Haskell et al., 2006).

Lawhead et al. (2004) reported few calves were observed within 1.2 miles of roads during spring caribou calving, and densities were reduced up to 2.4 miles from those same roads. Cameron et al. (2002) evaluated changes in the distribution of calving CAH caribou at the Kuparuk-Milne Point area. Before construction of a road system to Milne Point, caribou were found in a single, more or less continuous concentration, roughly centered where the road was later built. After construction of the road, caribou calved in areas to the east and west of the road. Ground observations of caribou within the Kuparuk area between 1978-1990 noted caribou increasingly avoided zones of intense activity, especially when calving (Smith, Cameron, and Reed, 1994).

Use of ice roads would cease in April, providing caribou time to adjust, and lessening the potential to affect calving caribou. Further, as ice roads melt and tundra begins growing, post-partum female caribou would remain unaffected by the melted ice road and would likely feed enough to enter fall in reasonable or good condition. A distribution shift in calving and lactating females may increase the competition for food resources between parturient caribou, which may lead to slight decreases in overall fitness. During winter, smaller bands of CAH caribou may persist in the area and could be affected by ice roads in small ways such as using ice roads as easy travel routes, but any population level effects would be unlikely. Consequently, the presence of ice roads should have a negligible level of effects on CAH caribou.

Wildlife-Human Interactions

Caribou are inquisitive and do not typically avoid buildings or facilities unless activity is occurring at a camp or work site. They frequently use the Trans-Alaska Pipeline as shade on sunny days, travel in areas where the pipeline is elevated, and travel along roads, so it is reasonable to assume some caribou would position themselves around buildings for protection from inclement weather, or for shade. Human activity associated with construction has the greatest potential to affect terrestrial mammals.

The CAH calves in the onshore portions of the pipeline, gravel pit, and ice roads routes, and some females and/or calves could be disturbed by workers at job sites. Potential effects from human activity would be greatest during spring when caribou are calving and from mid-June to mid-August when caribou may be seeking insect relief near the coast. Caribou disturbed at those times could

experience some non-critical energetic losses if excluded from coastal insect relief areas where the gravel pit, roads, or pipeline routes coincide with caribou presence. For this reason, interactions between personnel and wildlife would have a minor level of effects on caribou. If a wildlife avoidance plan is incorporated to curtail the presence of personnel in the vicinity of caribou during the calving season and at insect relief areas during periods of insect harassment, the level of effects could be mitigated to negligible.

Habitat Alteration

The construction of pipelines and other onshore facilities on the North Slope necessitates the use of very large quantities (several million tons) of gravel. With the construction of roads and gravel pads for facility-building sites, small areas of tundra vegetation are excavated at the gravel-quarry sites. However, the several square kilometers of caribou tundra-grazing habitat destroyed by onshore development represent a relatively small portion of available habitat to caribou and muskox populations. The construction of gravel mounds and pads may provide caribou with additional insect-relief habitat, particularly when there is little or no road traffic present. Conversely, the construction of pipelines could provide vectors by which invasive species and new diseases could be introduced to the area (Kutz et al., 2004; Urban, 2006), though establishment of invasive plant species in harsh environments can be difficult (Zefferman et al. 2015).

Cronin, Whitlaw, and Ballard (2000) recognized oil development may affect caribou in some manner, while maintaining that impacts have not resulted in negative population-level effects, particularly with the CAH which has grown during a period of oil-field development at rates comparable to those in undeveloped areas (Ballard, Cronin, and Whitlaw, 2000).

Understanding gross processes of habituation by caribou may aid in land management decisions and development of effective mitigation measures for industry and wildlife management agencies (Haskell et al., 2006). Haskell et al. (2006) argued that caribou habituation to oilfields recurs annually and is positively correlated with the timing of spring snowmelt.

Some residents on the North Slope believe caribou migration movements have changed since the construction of the Trans-Alaska Pipeline (Jonas Ningeok, as cited in Kruse et al., 1983a). Some residents from Kaktovik noticed caribou overwintering on the North Slope have become scarce since the development of the oil fields (Rexford, 1982). Recent studies (Roby, 1978; Cameron, Whitten, and Smith, 1981, 1983; Cameron et al., 1992; Pollard and Ballard, 1993; Joly, Nellemann, and Vistness, 2006) indicate significant seasonal avoidance of habitat near (within 4 km [2.4 mi]) some existing Prudhoe Bay area facilities by cows and calves during calving and early post-calving periods (May through June). For example, abundance of calving caribou in the Milne Point area declined significantly with progressive development (Noel, Parker, and Cronin, 2004; Joly, Nellemann, and Vistness, 2006). In the Milne Point area, Joly, Nellemann, and Vistness (2006) found there has been a gradual abandonment of developed areas of the oilfield during calving and a drop in abundance of calving caribou by at least 72% within the oil field, despite the fact that the CAH herd size has increased 4- to 5-fold during the same period (1978-2000). Since 1987, there has been a southward shift of the calving ground away from the oil-field study area. This has been attributed to the development of roads and pads in the calving grounds, which placed 92% of the study area within 4 km of the developments. The remaining undisturbed fragments were too small for continued use for concentrated calving (Joly, Nellemann, and Vistness, 2006). Proportionately, in relation to the increased herd size, the decline is much larger (Joly, Nellemann, and Vistness, 2006).

Caribou successfully cross under pipelines that are elevated a minimum of 7 ft above the tundra, a requirement for onshore pipelines in the National Petroleum Reserve-Alaska (NPR-A), and pipelines without adjacent roads and vehicle traffic are unlikely to affect caribou movements (Lawhead et al., 2006). Pipelines that impair caribou movement between insect-relief habitat and inland foraging areas could reduce food intake and slow rates of cow and calf weight gain (Smith, 1996). Caribou

reproductive success correlates with nutritional status (Cameron et al. 2002), so it is reasonable to assume adverse impacts to CAH reproduction would occur if caribou movements occurred during the July-August insect-relief season.

The physical presence of a pipeline alone would probably have minimal effects on the behavior, movement, or distribution of caribou (BLM, 2013). Even during winter, pipelines elevated at least 7 feet above ground may have adequate clearance between any snowdrifts and the pipe to allow caribou passage (Carruthers and Jakimchuk 1987). For these reasons, and because of the short length of onshore pipeline involved, a negligible level of effects from pipeline construction on caribou would occur under the Proposed Action.

These facts suggest caribou can habituate and adapt to oil-field infrastructure, and major impacts to caribou herds on the North Slope as a result of the Proposed Action are not likely. Consequently, the potential amount of habitat alteration would have negligible effects on CAH caribou.

Pipeline Construction

In the Kuparuk oil field, west of the LDPI, all pipelines are elevated a minimum of 5 feet above ground, and mosquito-harassed caribou pass through the field to and from insect-relief habitat. Smith et al. (1994) monitored caribou movement in relation to roads and increasing development in the Kuparuk Area from 1978 to 1990. They found groups of mosquito-harassed caribou were deterred from crossing roads with higher levels of vehicular traffic. Over the 12 year study, a change in access to the oil field area by insect-harassed caribou occurred. During the early years of construction, large insect-harassed groups of caribou approached the road from the middle section. By the end of the study, most large groups were observed at the extremes of the road transect, suggesting caribou might have been avoiding the core areas of industrial activity.

Construction of the pipeline tie-in pad and installation of the VSMs and aboveground portion of the pipeline would create onshore winter traffic. These activities could potentially cause short-term noise disturbance and displacement, or collisions with small numbers of caribou and muskoxen wintering on the Arctic Coastal Plain (ACP).

Oil Spills

Small Spills

In the event of a small spill (<1,000 bbls) some caribou in calving or insect relief areas could be directly exposed to the spill. Spills originating offshore would most likely contact caribou along beaches, shallow waters, and possibly in some of the coastal vegetated areas if windy conditions sprayed oil from wave tops into the air in nearshore areas. Onshore small spills from a rupture in the pipeline would most probably contaminate a much smaller area and be much less likely to impact caribou.

The effects of a small spill on caribou would also be determined by the coincidence of a spill and lifecycle timing for caribou. For example, a winter spill from an onshore pipeline would most likely have negligible levels of effect on any caribou since most of the CAH winters in and to the south of the Brooks Range, far from the proposed pipeline, and because winter conditions would permit cleanup crews to physically quickly remove the oil with relative ease. In comparison, a small spill from a ruptured nearshore pipeline near an insect relief area, could have adverse consequences if caribou entered the hydrocarbon-contaminated shallows and beaches while seeking relief from biting insects. In the most severe situation, a relatively small number of animals (perhaps a few hundred to a thousand) could potentially be directly exposed to the spill, and fewer still would have adverse physical reactions from hydrocarbon intake or external exposure.

The assumed size (<1,000 bbls) of a small spill would limit the number of animals that could be affected, particularly since an offshore small spill would be patchy and dispersed before it contacted

the shallows or beaches. An onshore spill within a restricted geographical area could more quickly and easily be cleaned and remediated than an offshore spill due to less lag time for spill response. Consequently, the level of effects from a small spill on caribou would be minor; however, with a spill response those same effects should be reduced to a negligible level of effects.

Large Spills

GLSs 156 (WAH (Western Arctic Caribou Herd) Insect Relief), 167 (TCH (Teshekpuk Lake Caribou Herd) Insect Relief/Calving), 174 (CAH (Central Arctic Caribou Herd) Insect Relief/Calving), 183 (PCH (Porcupine Caribou Herd) Insect Relief), and 184 (PCH Calving) were identified as important caribou habitat; however only GLS 174 and 167 had any contact probabilities $\geq 5\%$. All others had contact probabilities $< 5\%$ and so will not be analyzed further. GLS 177 also has some instances where the probabilities of contact from a spill would be $\geq 5\%$. Table 4.3.6-2 shows conditional probabilities of contact from a large spill in summer and winter, and the Annual probability of contact. A summer spill (1 Oct–30 June) has probabilities of 12-47% of contacting GLS 174 based on the number of days spill constituents are permitted to persist in the environment and whether the spill originated at the LDPI (LI) or the offshore portion of the proposed pipeline (PL). Likewise winter probabilities for contacting GLS 174 were 6-24% (Appendix A, Table A.2-9), and Annual Probabilities ranged from 7-30% (Appendix A, Table A.2-3).

Table 4.3.5-2. Conditional Probabilities of a Large LDPI or Pipeline Spill Contacting a Given ERA.

ID	GLS Name	1 day LI	1 day PL	3 days LI	3 days PL	10 days LI	10 days PL	30 days LI	30 days PL	90 days LI	90 days PL	360 days LI	360 days PL
174	CAH Insect Relief/Calving (Summer)	12	27	28	40	40	46	42	47	42	47	42	47
174	CAH Insect Relief/Calving (Winter)	6	13	14	19	20	22	22	24	22	24	22	24
174	CAH Insect Relief/Calving (Annual)	7	16	17	24	25	28	27	30	27	30	27	30
167	TCH Insect Relief/Calving (Summer)	<0.5	<0.5	<0.5	<0.5	<0.5	<0.5	4	2	5	3	5	3

The OSRA model also showed probabilities of contacting GLS 167 as $< 5\%$ until 90 days when the probability for a spill originating at the LDPI (LI) increased to 5%.

For this analysis, we assume that a large onshore pipeline spill could occur and oil less than 5 acres of vegetation along the pipeline landfall to the Badami tie in. Caribou should not be attracted to spills on the tundra, and such a spill has a limited ability to directly affect caribou though caribou could contact or ingest contaminated vegetation.

Oiled adult caribou would be unlikely to suffer from compromised insulation during summer, though they could absorb oil through the skin or inhale toxic hydrocarbons. Unlike adult caribou, caribou calves could suffer or die if the insulative abilities of their fur became compromised.

Caribou shed their fur in the late spring. Oiling events prior to their annual fur shedding would have a much smaller effect on such individuals; however, caribou whose fur became oiled after the spring fur shedding could not shed their oiled hair until the following summer. In the interim those individuals would periodically groom themselves, breed, calve, and nurse caribou calves. Such individuals would feel the effects of topical contamination and losses in insulation to a greater degree than those who were able to shed their fur along with any remaining hydrocarbons.

Toxicity studies of crude oil ingestion in cattle (Rowe, Dollahite, and Camp, 1973) showed the possibility of anorexia (significant weight loss) and aspiration pneumonia leading to death. Caribou oiled by contact with a spill in lakes, ponds, rivers, or coastal waters might then die by inhaling toxic hydrocarbons or absorbing them through the skin if exposed to large quantities of hydrocarbon. The potential mortalities associated with large spills, particularly those originating in the offshore environment indicate large spills could have a moderate level of effects on caribou. If an appropriate

oil spill response was implemented those effects could be mitigated and reduced to negligible levels of effects.

Spill Response

Caribou have been observed using sea ice as a salt lick, and it is possible that they may ingest oil from contaminated sea ice during spring (USDOJ, MMS, 1983; Rexford, 1996; ExxonMobil, 2002).

In the event of a large oil spill contacting and extensively oiling coastal habitats with herds or bands of caribou during the insect season, the presence of humans, boats, and aircraft operating in the area involved in cleanup activities is expected to cause displacement of some caribou in the oiled areas and contribute temporarily to seasonal stress on some caribou. This effect is expected to occur during cleanup operations (perhaps 1 or 2 seasons) but is not expected to significantly affect the caribou herd movements or the foraging activities of the populations.

Analysis of effects

4.3.5.1.3. Alternative 2 (No Action)

The No Action alternative would not impact caribou. Local caribou populations would continue with current population trends (Section 3.2.5).

4.3.5.1.4. Alternative 3 (Alternate Locations for proposed LDPI)

The effects and levels of effect from Alternative 3 would be the same as described for the Proposed Action because the level of onshore activity and aircraft traffic would be anticipated to be the same despite moving the offshore gravel island.

4.3.5.1.5. Alternative 4 (Onshore Processing Locations)

In this alternative, oil and gas processing would be relocated from the proposed LDPI to an onshore processing facility either at 1) Endicott (an existing facility) or 2) a new onshore facility.

Alternative 4A (Relocating to Endicott as a processing location) would have negligible effects on caribou because Endicott is an existing facility with ongoing activity and traffic patterns already in place.

Relocation to build a new processing facility at an onshore location would require additional construction onshore that would create additional habitat losses and disturbances, plus introduce the year-round presence of people as an added disturbance type and risk to caribou. Such disturbances could have serious adverse effects on caribou calving and insect relief by discouraging caribou presence in the area around the facility. Furthermore, if year-round access to the facility is necessary, there could be an increased risk to caribou from vehicle collisions. Because the onshore areas south of the proposed LDPI are considered calving grounds for the CAH, there could be long-term adverse effects to those elements of the CAH that normally select coastal areas for calving. The level of effects from habitat loss would be moderate, and it is unlikely that mitigation measures addressing habitat loss would be implemented.

The potential for a year-round access road to transport personnel to and from the work site would create an ongoing disturbance that could not be mitigated, leading to a moderate level of effects. The additional year-round vehicle traffic needed for an onshore processing facility would also have an added adverse effect on calving caribou, rendering portions of the calving grounds less suitable or unsuitable for calving. For this reason vehicle traffic under Alternative 4b would have a moderate level of effect on CAH caribou.

4.3.5.1.6. Alternative 5 (Alternate Gravel Sources)

The effects and levels of effect from Alternative 5 on Caribou would be the same as was described for the Proposed Action because the alternate mine sites would be located in similar habitat as the proposed mine sites, and roughly the same size and construction schedule.

4.3.5.2. Muskox

4.3.5.2.1. The Proposed Action

Aircraft Operations

Muskoxen cows and calves appear to be more responsive to helicopter traffic than males and groups without calves, and muskoxen in general are more sensitive to overflights by helicopter than by fixed-wing aircraft (Miller and Gunn, 1979; Reynolds, 1986). A cow disturbed during the calving season may abandon her calf, if the calf is a day or two old (Lent, 1970). However, muskoxen may habituate to helicopter flights above 500 ft (180 m), at least for a time (Miller and Gunn, 1980).

Helicopter support traffic seemed to have a cumulative effect on muskoxen responses to seismic activities (Jingfors and Lassen, 1984). In some areas muskoxen reacted to helicopters flown at 325 and 1,300 ft (100 and 400 m) with response durations lasting from 2-12 minutes (Miller and Gunn, 1984).

The use of helicopters would potentially have a moderate level of effects on muskoxen, because of the strong startle response muskoxen have to approaching aircraft at low altitudes. Requiring mitigation measures such as minimum altitudes of 1,500 ft, and prohibiting onshore helicopter flights near muskox calving areas, or groups would greatly lessen the potential for startle responses, injuries, and separations of parturient muskoxen from their calves. With such mitigations the level of effects of helicopter use would be reduced to negligible.

Vehicle Operations

Unlike caribou, muskoxen are mostly sedentary creatures that concentrate of their feeding activity in riparian areas, making them less likely to use roads or encounter vehicles.

Muskoxen occur in much lower numbers than caribou, and are widely distributed. Though muskoxen occur in the Prudhoe Bay Oilfield, the probability of vehicle-muskox collisions remains low, though some avoidance behaviors could occur.

For these reasons the potential level of effects of vehicle operations on muskox would be minor, since no mortalities or population-level effects are expected. Requiring mitigation measures such as restricting the use of vehicles to the area immediately around work areas and camps, and avoiding muskox by 600 m (0.37 mi) would reduce the impacts to a negligible level of effect.

Heavy Equipment

The use of heavy equipment would likely cause muskoxen to avoid feeding, sleeping, or calving in the vicinity of such activity. Their avoidance of heavy equipment operations should be similar to what was described above. For these reasons the level of effects to muskox from heavy equipment operations would be negligible.

Gravel Mining

Muskoxen use riparian habitats on the North Slope, such as where the gravel-mining site would be located. There is a great deal of similar habitat throughout the local area such that the amount of habitat changed via gravel mining would have no measureable effects on muskox. Likewise the activities associated with gravel mining would only serve to exclude muskoxen from a miniscule portion of their potential habitat in the area. After the gravel mine is abandoned there may be a

permanent pond at the mine site, however such a habitat change should have no measureable long-term effects on muskox. For these reasons the level of effects from gravel mining on muskoxen would be negligible and require no special mitigations.

Onshore Ice Roads

The use of onshore ice roads from the Endicott road to the gravel mine and from the gravel mine to the proposed LDPI would require an ice road be constructed through about 8.5 acres of land, ponds, and streams. There should be no long-term effects of the ice roads on muskox habitat use since the roads would melt away every spring. Since muskoxen generally do not browse during winter, relying on fat reserves instead, there would be limited effects from onshore ice roads on muskox foraging opportunities. Other than the issues of traffic, gravel mining, and heavy equipment operations which have already been addressed, the level of effects on muskoxen from ice road presence would be negligible.

Wildlife-Human Interactions

Muskoxen are large, powerful animals that are endowed with sharp horns, thickened skulls to prevent head injuries during the rut, a great deal of speed, and males often exhibit a volatile temperament. If Proposed Action personnel were to approach muskoxen too closely the animals could react defensively and injure or kill humans. Work in remote areas of Alaska typically necessitates bear guards, who are trained and equipped with firearms to prevent injuries or deaths to workers from aggressive or defensive bears. In a situation where a muskox attacked a worker there is a strong possibility the armed guard(s) would be forced to shoot the animal, rather than let it injure or kill a human being. The level of effects in such cases would be moderate, since it would result in the death of the animals; however, with a wildlife avoidance plan that includes keeping a safe distance from muskoxen, level of effects would mitigate impacts to negligible.

Habitat Alteration

Potential effects of oil-development activities include direct habitat loss from gravel mining, facility and pipeline construction, and indirect habitat loss through reduced access caused by physical or behavioral barriers created by roads, pipelines, and facilities (Clough et al., 1987, as cited by Winters and Shideler, 1990; Garner and Reynolds, 1986).

During summer, muskoxen form relatively small groups and travel more widely than during winter when groups tend to be larger and more sedentary (Lenart 2011b), and so could be constantly exposed to oil exploration and development. Since they tend to remain in the same general area year-round (Jingfors, 1982), receiving constant exposure to roads, pipelines, etc., they may be more likely to habituate to various activities. The total onshore habitat area disturbed in the Proposed Action would amount to 130 acres for the pipeline, 45 acres for the Construction and Emergency Response Offices - Grounded Pond, 31 acres for the Pipeline Crew Staging – Grounded Pond, and 21 acres for the gravel mine, for a total of 227 acres of habitat disturbance (Hilcorp, 2015). Because of the restricted size of potential disturbed habitat, and the short length of onshore pipeline, the level of effects from habitat disturbance on muskoxen would be negligible.

Pipeline Construction

Muskoxen have been exposed to the TAPS, and pipelines throughout the Prudhoe Bay, Kuparuk, Alpine, and Badami oil fields for decades, but remain in those areas year round (Jingfors, 1982). Unless disturbed by people, muskoxen may feed near aboveground sections of pipelines (DeathMagneticgil, 2011). In fact, muskoxen have expanded westward from the Arctic National Wildlife Refuge to use the Sagavanirktok River valley in spite of the road systems and pipelines that were present and continue to be built (Reynolds, Wilson, and Klein, 2002). Construction of the pipeline tie-in pad and installation of the VSMs and aboveground portion of the pipeline would create

onshore winter traffic. These activities could potentially cause short-term noise disturbance and displacement, or collisions with small numbers of caribou and muskoxen wintering on the ACP. However, pipeline construction is expected to have a negligible level of effect on muskoxen.

Oil Spills

Small Spills

Small spills occurring in the offshore could only affect muskox in the water or along the coastline. The effects would be similar to what was described for caribou; however the low population density of muskoxen would make the likelihood of muskoxen contacting spilled materials from a pipeline rupture very remote. Spill response activities would further reduce the likelihood for contact, such that the level of effects from a small spill on muskoxen would be negligible.

Large Spills

GLSs 185 (Yukon Muskox Wintering), and 177 (Beaufort Muskox) were identified as important Muskox habitat; however, GLS 185 has contact probabilities <5% and will not be analyzed further. Instead a general OSRA analysis shows Land (ERA 0) could be contacted, potentially exposing some muskoxen to spilled materials. GLS 177 also has some instances where the probabilities of contact from a spill would be $\geq 5\%$. Table 4.3.6-3 shows conditional probabilities of contact from a large spill in summer and winter, and the annual probability of contact. A summer spill (1 Oct–30 June) has probabilities <5% of contacting GLS 177; however some winter probabilities (30, 90, and 360 days) are $\geq 5\%$ for large spills originating at the LDPI (LI), and are shown in Table 4.3.6-3.

Table 4.3.5-3. Conditional Probabilities of a Large LDPI or Pipeline Spill Contacting a Muskox ERA.

ID	Environmental Resource Area Name	1 day LI*	1 day PL*	3 days LI	3 days PL	10 days LI	10 days PL	30 days LI	30 days PL	90 days LI	90 days PL	360 days LI	360 days PL
0	Land (1 July–30 Sep)	25	53	54	74	74	85	85	91	88	93	88	93
0	Land (1 Oct–30 Jun)	22	51	51	72	72	84	84	90	88	93	88	93
0	Land (1 Jan–31 Dec)	22	51	52	72	72	84	84	90	88	93	88	93
177	Beaufort Muskox Habitat (Winter)	<0.5	<0.5	1	0	4	1	5	2	5	2	5	2

Note: LI = Liberty Development and Production Island. PL = pipeline.

The information contained in Table 4.3.6-3 indicates that should a large spill occur at the proposed LDPI, there is a 22-88% probability of the spill contacting a coastal area within 360 days of release, and a 51-93% probability of such a spill originating from the offshore portion of the proposed pipeline contacting land.

Large spills occurring in the offshore environment from the proposed LDPI or the submerged sections of the pipeline could affect muskoxen in a manner consistent with that described for caribou above. Unlike caribou the potential exists to only affect a few muskoxen due to their sparse distribution across the North Slope and their tendency to remain in a general area for extended periods of time. Furthermore, muskoxen do not seek areas of insect relief. Instead, they rely on their thick long fur to protect them from insects. Large spills from an onshore pipeline rupture would be unlikely to affect muskoxen, though the spill response may serve to keep muskoxen away from spilled materials. Overall, a large spill would have a minor level of effect on muskoxen; however implementation of an oil spill response plan would reduce the impacts to a negligible level of effects.

Oil Spill Response

In the event of a large oil spill contacting and extensively oiling coastal habitats with herds or bands of muskoxen, the presence of humans, boats, and aircraft operating in the area involved in cleanup activities is expected to cause displacement of some muskox in the oiled areas and contribute temporarily to seasonal stress. This effect is expected to occur during cleanup operations (perhaps 1

or 2 seasons) but is not expected to significantly impact any muskox movements, or foraging activities.

For the most part, the effect of onshore oil spills would be very local and would contaminate tundra in the immediate vicinity of the pipeline; such spills would not be expected to significantly contaminate or alter muskoxen range or habitat use within most of the proposed pipeline corridor.

The effects of climate change on muskox under the Proposed Action, for the lifespan of the proposed action, would not differ from what was described in Section 3.2.5. Likewise the expected changes to the environment from climate change over the next 30 years should not substantially alter the effects of the Proposed Action or their impacts on muskox.

4.3.5.2.2. Alternative 2 (No Action)

The No Action alternative would not impact muskoxen. Local muskox populations would continue with current population trends (Section 3.2.5).

4.3.5.2.3. Alternative 3 (Alternate Locations for proposed LDPI)

The effects and levels of effect from Alternative 3 would be the same as described for the Proposed Action because the level of onshore activity and aircraft traffic would be anticipated to be the same despite moving the offshore gravel island.

4.3.5.2.4. Alternative 4 (Onshore Processing Locations)

In this alternative, oil and gas processing would be relocated from the gravel island to an onshore processing facility either at 1) Endicott (an existing facility) or 2) a new onshore facility

Relocating to the Endicott as a processing location would have negligible effects on muskoxen because Endicott is an existing facility with traffic patterns already in place.

Relocation to build a new processing facility at an onshore location would require additional construction onshore that would create additional habitat losses and disturbances, plus introduce the year-round presence of people as an added disturbance type and risk to muskox. Such disturbances could have serious adverse effects on calving and foraging by discouraging muskox presence in the area around the facility. Furthermore, if year-round access to the facility is necessary, there could be an increased risk to muskox from vehicle collisions. The onshore areas south of the LDPI have some muskox habitat, and there could be long-term adverse effects to muskox that feed or calve in coastal areas, particularly riparian areas. The level of effects from habitat loss would be moderate and unlikely to be mitigated.

Any year-round access road to transport personnel to and from the work site would create an ongoing disturbance that could not be mitigated, leading to a moderate level of effects. The additional year-round vehicle traffic needed for an onshore processing facility would also have an added adverse effect on muskox, which do leave riparian areas during spring, summer and fall to feed in coastal areas. For this reason vehicle traffic under Alternative 4 would have a minor level of effect on muskox.

4.3.5.2.5. Alternative 5 (Alternate Gravel Sources)

The effects and levels of effect from Alternative 5 would be the same on muskoxen as was described for the Proposed Action because the alternate mine sites would be located in similar habitat as the proposed mine sites, and roughly the same size and construction schedule.

4.3.5.3. Grizzly Bear

4.3.5.3.1. The Proposed Action

Aircraft Operations

Harding and Nagy (1980) noted 88% of bear responses to helicopters involved running and hiding. Though grizzly bears are widely distributed across the North Slope of Alaska, the low productivity of the local plant communities requires individual bears maintain large home ranges to support them. Consequently, few grizzlies would be encountered by any one flight, and multiple flights over the same land area would potentially affect the same set of bears. In such instances a female grizzly could become separated from her cubs, which could lead to injury or mortality of cubs, or injury to the mother as they try to escape the perceived threat of a helicopter. For this reason helicopter use would potentially have a moderate level of effects on grizzly bears; however if a $\geq 1,500$ ft AGL altitude requirement is implemented as a mitigation strategy, those effects could be reduced to a negligible level of effects.

Vehicle Operations

Vehicle use on ice roads during winter should not affect grizzly bears which would be engaged in hibernation. The home range sizes for individual grizzly bears on the North Slope of Alaska limits the numbers of bears potentially affected; and because of the short growing season, by mid-October most female grizzlies are in dens where they remain until early June. Likewise around 80% of the males have denned up by November first, though they sometimes leave their dens a little earlier than the female bears (Shideler and Woodford, 2015). For these reasons vehicle operations would have a negligible level of effects on grizzly bears.

Heavy Equipment

Onshore heavy equipment operations would occur concurrently with ice road construction and operations between December and April, at a time when grizzly bears would be hibernating. Consequently, the use of heavy equipment in the onshore environment would have a negligible level of effects on grizzly bears.

Gravel Mining

Grizzly bears use earthen dens along riverbanks and elevated dry areas similar to where gravel extraction would occur. This mining activity could destroy some dens, potentially injuring or killing animals in their dens. Bears would also be susceptible to being disturbed from their dens during winter and early spring when they should be hibernating. The low population density of grizzlies in the area precludes any population-level events from occurring due to gravel mining; however some bears might be crushed or frightened from the area during gravel mining operations. This risk of a low number of grizzly mortalities indicates gravel mining would have a moderate level of effects on grizzlies. If the proponent were to discourage bears from denning in or near the mine site, and avoid existing dens, the level of effects would be reduced to minor.

Onshore Ice Roads

Onshore ice roads would be constructed in December and in use from December to the end of April, to facilitate installation of the onshore segments of LDPI pipeline and tie it in with the existing pipeline infrastructure. This time frame occurs within the October/November - late April denning period for grizzly bears. Consequently, few grizzly bears should be immediately disturbed by ice road construction, maintenance, or use. The ice road could cross or pass by active grizzly bear dens, which could lead to grizzlies being disturbed from their dens in winter, or cause collisions between vehicles/heavy equipment and bears, or bear-human conflicts. Some bears could be driven from their dens in winter, with no alternate locations for hibernation, which could create the potential for bear

mortality due to vehicle/heavy equipment collisions or bear-human conflicts. Thus, the expected level of effects would be moderate. Potential mitigation measures would require the project proponent to survey the onshore segment of the ice road route and make route alterations to avoid bear dens, limit the traveling speed of vehicles/equipment to 25 mph, and establish grizzly bear-human avoidance protocols to ensure bears aren't attracted to work areas or people. If these measures are adopted the level of effects from onshore ice road construction and use would be negligible.

Wildlife-Human Interactions

Some bears are likely to habituate to human noise and presence, leading to increased encounters. Grizzlies typically respond to ground-based human activities more strongly than to aircraft, especially when encounters occur in open areas such as the Arctic Slope (McLellan and Shackleton, 1988). Harding and Nagy (1980) noted grizzly bears in Canada habituating to camps and human activity, with few actually entering camps. Most bears were frightened off by groups of people or vehicles, however a few individuals who continually entered camps had to be captured and relocated to other areas. The establishment of permanent settlements (oil fields, mines, etc.) usually leads to human-bear encounters on a regular basis and to conflict, particularly when bears learn to associate humans with food (Schallenberger, 1980; Harding and Nagy, 1980; Miller and Chihuly, 1987; McLellan, 1990).

The presence of food acts as a strong attractant for bears, especially in areas and times when natural high quality foods are scarce. Bears are very adaptable and quickly learn to exploit human food resources, so they could easily be attracted to work areas by food left in vehicles, or around work areas or camps. Furthermore, sometimes their inquisitive nature can induce bears to visit camps or work areas for curiosity's sake. However, individual bears vary in the degree of habituation-tolerance to human presence, and some will continue to avoid areas where humans are present (Olson and Gilbert, 1994). The attraction of grizzly bears to garbage and/or food odors at field camps and other facilities has led to the loss of bears in the past (Schallenberger, 1980). Once bears become conditioned to the availability of human sources of food, measures to reduce this availability by improved garbage handling are not always effective (McCarthy and Seavoy, 1994). Bears will make an extra effort to get to the food sources that they are conditioned to having. Cubs of female bears conditioned to anthropogenic food source and habituated to human presence have a higher survival rates as cubs but have a high mortality rate after they are weaned (Shideler and Hechtel, 2000). These young-habituated bears are more vulnerable to human-bear encounters near settlements; people often will not accept the risk of bear attacks, and these encounters often lead to the loss of bears (Archibald, Ellis, and Hamilton, 1987).

Visits to camps and work areas could result in bear attacks on people or damaged equipment or vehicles, and any bears that attack humans would most likely be hunted down and exterminated. Due to the risk of being killed in defense of life wildlife-human interactions could have a moderate level of effects on grizzly bears; however, if mitigations such as a grizzly bear interaction plan that minimizes the potential of bear-human interactions were developed and implemented, the level of effects would be reduced to negligible.

Habitat Alteration

Potential effects of oil-development activities include direct habitat loss from gravel mining, facility and pipeline construction, and indirect habitat loss (227 acres) through reduced access caused by physical or behavioral barriers created by roads, pipelines, and facilities (Clough et al., 1987, as cited by Winters and Shideler, 1990; Garner and Reynolds, 1986). Due to the restricted size of potential disturbed habitat, and the short length of onshore pipeline, the level of effects from habitat disturbance on grizzly bears would be negligible.

Pipeline Construction

Pipelines would be constructed during winter when bears hibernate, and would either be buried or elevated above the tundra. Unlike caribou or muskoxen, grizzly bears are not known to be adversely impacted by the presence of pipelines so the level of effects to grizzly bears from pipeline construction and presence would be negligible.

Oil Spills

Because grizzly bears hibernate they could only be affected by oil spills between late April and early November. Only a large spill from the proposed LDPI or pipeline that occurred during this time period has the potential to impact grizzly bears, and only at key locations.

Small Spills

Small petroleum spills should have no noticeable effects on grizzly bears. Small spills from the LDPI would have little chance of contacting places where grizzly bear presence would be an issue, due to the small size of the spill and the location of the LDPI. While small offshore and onshore pipeline spills could be contacted by grizzlies under a limited set of conditions (May-October timeframe, in the area when a spill occurred, etc.) the most likely scenario for a small spill would unfold with no grizzly bears anywhere near the spill site (onshore pipeline) or contaminated shorelines (offshore pipeline). For this reason the level of effects from a small pipeline spill would be negligible. If a spill response is implemented, that level of effects would be lower, but remain negligible.

Large Spill

GLSs 160 (Ledyard Brown Bears), and 163 (Kasegaluk Brown Bears) were identified as important grizzly bear habitat; however, both have contact probabilities <5% so they will not be analyzed further. Instead a general OSRA analysis shows Land (ERA 0) could be contacted, potentially exposing some grizzly bears to spilled materials. Table 4.3.6-4 shows conditional probabilities of contact from a large spill in summer and winter. A winter spill (1 Oct–30 June) could contact bears if the materials persist in the environment or if the spill occurred before/after hibernation.

Table 4.3.5-4. Conditional Probabilities of a Large Spill Contacting a Grizzly Bear Habitat or ERA.

ID	Environmental Resource Area Name	1	1	3	3	10	10	30	30	90	90	360	360
		day	day	days	days	days	days	days	days	days	days	days	days
		LI	PL	LI	PL	LI	PL	LI	PL	LI	PL	LI	PL
0	Land (1 July–30 Sep)	25	53	54	74	74	85	85	91	88	93	88	93
0	Land (1 Oct–30 Jun)	22	51	51	72	72	84	84	90	88	93	88	93
0	Land (1 Jan–31 Dec)	22	51	52	72	72	84	84	90	88	93	88	93

The information contained in Table 4.3.6-4 indicates that should a large spill occur at the proposed LDPI, there is a 22-88% probability that it would contact a coastal area within 360 days of release, and a 51-93% probability of a spill originating from the proposed pipeline contacting land.

A large spill from onshore segments of the proposed pipeline is unlikely to adversely impact grizzly bears, since the spill would contaminate a comparatively small area of habitat where the soil is underlain with permafrost that prevents oil from infiltrating deeply into the soil. The small area contaminated by a large onshore spill would only occur within the home range of a single bear and it is unlikely the bear would be drawn to such an area. For this reason the level of effects to grizzly bears from a large onshore spill would be negligible.

A large offshore spill originating from pipeline or the LDPI has the potential to contact sections of coastline where some grizzly bears may scavenge for food; however, it is unlikely more than one or two bears would visit a contaminated coastal area at any given time, since grizzlies are so thinly distributed across the Arctic Coastal Plain (ACP) of Alaska. Any bear that did contact oil could

inhale, or possibly ingest oil from feeding on contaminated beach castings or carrion, or from grooming a pelt that was covered in oil. The quantity of oil ingested/contacted, and the individual health of a bear, would determine how severe the effects on a grizzly bear would be, such that some bears exposed to oil might remain unimpacted, while others could die. If bears fed on contaminated prey, such as dead caribou that were oiled, the worst effects of a spill on grizzly bears could be manifested.

Assuming the most extreme result of contact did occur, a small number of bears might die after being exposed to oil, which meets the criteria for a moderate level of effects. If a spill response plan were in place and implemented, and if any contaminated food items were removed, the level of effect on grizzly bears would be reduced to negligible.

Oil Spill Response

Cleaning up a large oil spill also would disturb some grizzly bears. The presence of large numbers of humans, boats, and several aircraft operating to clean up the area probably would displace some grizzly bears. An oil spill could also result in the loss of small numbers of grizzly bears through ingestion of contaminated prey or carrion, or from grooming contaminated fur.

For the most part, the effect of onshore oil spills would be very local and would contaminate tundra in the immediate vicinity of the pipeline; these spills would not be expected to significantly contaminate or alter grizzly bear range within the pipeline corridors.

The effects of climate change on grizzly bears under the Proposed Action, for the lifespan of the proposed action, would not differ from what was described in Section 3.2.5. Likewise the expected changes to the environment from climate change over the next 30 years should not substantially alter the effects of the Proposed Action or their impacts on grizzly bears.

4.3.5.3.2. Alternative 2 (No Action)

The No Action alternative would not impact grizzly bears. Local grizzly populations would continue with current population trends (Section 3.2.5).

4.3.5.3.3. Alternative 3 (Alternate Locations for proposed LDPI)

The impacts and levels of effect from Alternative 3 would be the same for grizzly bears as described for the Proposed Action because the level of onshore activity and aircraft traffic is anticipated to be similar despite moving the offshore gravel island.

4.3.5.3.4. Alternative 4 (Onshore Processing Locations)

In this alternative, oil and gas processing would be relocated from the proposed LDPI to an onshore processing facility either at 1) Endicott (an existing facility) or 2) a new onshore facility.

Relocating to the Endicott as a processing location would have negligible effects on grizzly bears because Endicott is an existing facility with ongoing activity and traffic patterns already in place.

Relocation to build a new processing facility at an onshore location would require additional construction onshore that would create additional habitat losses and disturbances, plus introduce the year-round presence of people as an added disturbance type and risk of human grizzly encounters. Though most effects to grizzlies from Alternative 4 would not change greatly, the risk of encounters between bears and people would increase greatly, since personnel and operations would be occurring year-round. Under these conditions some grizzlies might have to be killed in defense of life which would have a moderate level of effects on grizzly bears; however, if bear avoidance measures are implemented, as is done elsewhere in the Prudhoe Bay oilfield, those effects would likely be mitigated to minor or negligible.

4.3.5.3.5. Alternative 5 (Alternate Gravel Sources)

The impacts and levels of effect from Alternative 5 on grizzly bears would be the same as described for the Proposed Action because the alternate mine sites would be located in similar habitat as the proposed mine sites, and roughly the same size and construction schedule.

4.3.5.4. Arctic Fox

4.3.5.4.1. The Proposed Action

Aircraft Operations

No known adverse effects of aircraft operations on Arctic foxes have been documented. In other parts of Alaska, such as Shemya Island, Arctic foxes regularly approach aircraft on runways and appear unimpacted by aircraft take-offs or landings. Low altitude helicopter flights might frighten or disturb some Arctic foxes; however such events would likely be rare, and Arctic foxes are both resourceful and resilient. Consequently, any effects from aircraft operations on Arctic foxes would be brief, and would not compromise their ability to survive. For these reasons the level of effects of aircraft operations on Arctic foxes should be negligible.

Vehicle Operations

Vehicles could potentially strike and kill foxes and rodents (Hilcorp, 2015, Appendix A). Though some individual foxes could die, no population-level effects would occur and due to the high fecundity of Arctic foxes, any losses in the local population should recuperate within one or two years. Because of the potential for mortalities, the level of effects from vehicle operations on Arctic foxes would be moderate; however, if speed limits of around 25 mph, and avoidance protocols are implemented under the Proposed Action, the level of effects should be reduced to negligible.

Heavy Equipment

Arctic foxes should be briefly impacted by the presence and operations of heavy equipment at the proposed LDPI, on ice roads, or along the pipeline corridor. Heavy equipment normally moves at a slower pace than an Arctic fox. Consequently, no Arctic foxes should be injured by heavy equipment operation under the Proposed Action. For this reason the use of heavy equipment should have a negligible level of effects on Arctic foxes.

Gravel Mining

Arctic foxes drawn into mining areas could be killed or injured by vehicles, heavy equipment crushing den sites, falling rocks/gravel, or by consuming toxic substances such as antifreeze. For these reasons the level of effects from gravel mining on Arctic foxes would be moderate; however development and implementation of an interaction plan that prohibits feeding foxes or otherwise attracting them would reduce the level of effects to negligible.

Ice Roads

Arctic foxes show no avoidance of roads or ice roads as they wander throughout the Prudhoe Bay Oilfield. It is reasonable to assume some would periodically wander onto ice roads in both onshore and offshore areas. There is potential for vehicles to hit and kill Arctic foxes on ice roads, making the level of effects of ice road construction and use moderate. Potential mitigation measures would require speeds of 25 mph and avoidance protocols for drivers and workers on the ice roads, which mitigate effects to a negligible level.

Wildlife-Human Interactions

Arctic foxes are primarily scavengers during winter, and feed mostly on birds, eggs, rodents, and carrion during summer. They have also been known to kill and consume ringed seal pups.

Furthermore, they are widely known to openly approach people, seeking scraps of food. This has the potential to increase the overwintering survival rates of Arctic foxes in the area of the Proposed Action, both onshore, and during winter at the proposed LDPI site, if they can access food at those areas. Potentially such added food resources, and the increased survival rates, could lead to artificially elevated numbers of Arctic foxes in the area, which would have a corresponding increase in predation on their prey species (Burgess and Banyas, 1993; Burgess et al. 1993).

Habitat Alteration

Arctic foxes could benefit from onshore facilities and pipeline development. Crawlspace under buildings, culverts, and pipes provide sometimes foxes with shelter for resting and, in some cases, artificial dens (Eberhardt et al., 1982; Burgess and Banyas, 1993). Oil development has not harmed the fox population around Prudhoe Bay, Alaska (Eberhardt et al., 1982). Arctic fox numbers and productivity are higher in the Prudhoe Bay area compared to adjacent undeveloped areas (Burgess et al., 1993).

Pipeline Construction

Pipeline construction could have some adverse effects on Arctic foxes if fox dens were to be disturbed or damaged. In such incidents, fox kits could be crushed, or displaced from the safety of a den at an early stage in their development. If such a thing were to happen, the displaced fox kits could be more vulnerable to the elements and predation, which could lead to mortalities. Because of the potential for mortalities, the level of effects from pipeline construction would be moderate; however, if the pipeline route was surveyed before construction, the destruction of fox dens could be avoided. If such avoidance measures are implemented, the level of effects to Arctic foxes from pipeline construction would be negligible.

Oil Spills

Small Spills

Over the production life of the sale, 30 small crude oil spills (,1,00 bbl) and 40 small refined oil spills (average of 0.7 bbl) are estimated to occur (Appendix A, Table A.1-1). Some tundra vegetation in the pipeline corridor would become contaminated from these spills. If a pipeline spill occurred, it is likely that control and cleanup operations (ground vehicles, air traffic, and personnel) at the spill site would frighten Arctic foxes away from the spill area and prevent any Arctic foxes from contact with the spill. Small offshore spills would be unlikely to impact Arctic foxes, since small spills would mostly volatilize and disperse before contacting the coast. If small offshore spills were to occur during winter, much of the spill would be swept up in currents, but remain under the sea ice and unreachable to Arctic foxes. Though sea ice melts and portions of an under ice spill could eventually reach the coast after the spring and summer melt, such spill materials would be weathered, and disperse slowly in tandem with the rate of ice melt. For these reasons small spills are expected to have a negligible level of effect on Arctic foxes.

Large Spill

If a large offshore spill were to occur, areas of the coastline could become contaminated. Because Arctic foxes often scavenge along coastlines, they could be contacted by large spills during the open-water season. During winter a large offshore spill would mostly occur under ice, making it unreachable by foxes, until the spring thaw. As with small spills such a release of icebound spill materials would occur gradually, allowing dispersal and weathering to occur. If a fox became drenched with spilled materials and the insulative abilities of its fur became compromised, hypothermia and death could occur among a few individual foxes. A large onshore spill from a ruptured pipeline would be unlikely to impact Arctic foxes, since workers would be cleaning the spill

up, and the presence of cleanup activities would discourage foxes from approaching the areas where they could become contaminated.

No ERAs or GLSs identifying particularly important Arctic fox habitat have been described so a general OSRA analysis shows Land (ERA 0) the following conditional probabilities of contact from a large spill in summer and winter (Table 4.3.6-5).

Table 4.3.5-5. Chance of a Large Spill on LDPI or Pipeline Contacting an Arctic Fox Habitat or ERA.

ID	Environmental Resource Area Name	1 day LI	1 day PL	3 days LI	3 days PL	10 days LI	10 days PL	30 days LI	30 days PL	90 days LI	90 days PL	360 days LI	360 days PL
0	Land (1 July–30 Sep)	25	53	54	74	74	85	85	91	88	93	88	93
0	Land (1 Oct–30 Jun)	22	51	51	72	72	84	84	90	88	93	88	93
0	Land (1 Jan–31 Dec)	22	51	52	72	72	84	84	90	88	93	88	93

The information contained in Table 4.3.6-5 indicates that should a large spill occur at the proposed LDPI, there is a 22-88% probability that it would contact a coastal area within 360 days of release, and a 51-93% probability of a spill originating from the proposed pipeline contacting land

Because of the potential mortalities, large spills would have a moderate level of effects on Arctic foxes; however, oil spill response activities should discourage foxes from approaching the area of spill contamination. With the spill response activities, the large spill would have a negligible level of effects on Arctic foxes.

Oil Spill Response

Cleaning up a large oil spill also would disturb some Arctic foxes. The presence of humans, boats, and aircraft operating to clean up the area probably would displace some Arctic foxes. An oil spill could also result in the loss of small numbers of Arctic foxes through ingestion of contaminated prey or carrion, or from grooming contaminated fur.

For the most part, the effect of onshore oil spills would be very local and would contaminate tundra in the immediate vicinity of the pipeline; these spills would not be expected to significantly contaminate or alter Arctic fox range within the pipeline corridors.

The effects of climate change on Arctic foxes under the Proposed Action, for the lifespan of the proposed action, would not differ from what was described in Section 3.2.5. Likewise the expected changes to the environment from climate change over the next 30 years should not substantially alter the effects of the Proposed Action or their impacts on Arctic foxes.

4.3.5.4.2. Alternative 2 (No Action)

The No Action alternative would not impact Arctic foxes. Local populations of Arctic fox would continue with current population trends (Section 3.3.5).

4.3.5.4.3. Alternative 3 (Alternate Locations for proposed LDPI)

The effects and levels of effect from Alternative 3 would be the same for Arctic foxes as described for the Proposed Action because the level of onshore activity and aircraft traffic would be anticipated to be the same despite moving the offshore gravel island.

4.3.5.4.4. Alternative 4 (Onshore Processing Locations)

In this alternative, oil and gas processing would be relocated from the proposed LDPI to an onshore processing facility either at 1) Endicott (an existing facility) or 2) a new onshore facility.

Relocating to the Endicott as a processing location would have negligible effects on Arctic foxes because Endicott is an existing facility with traffic patterns already in place.

Relocation to build a new processing facility at an onshore location would require additional construction onshore that would create additional habitat losses and disturbances, plus introduce the year-round presence of people as an added disturbance type and risk to Arctic foxes. Unlike other terrestrial mammal species Arctic foxes frequently den in gravel pads, and other man-made protected areas with good drainage. Consequently, the loss in natural habitat from construction of an onshore processing facility could be more than compensated for by creating ideal denning habitat for Arctic foxes with a gravel pad. A drawback to the creation of new denning habitat is the potential to attract red foxes to the area. Red foxes regularly attack and kill Arctic foxes where their ranges overlap, however the lack of suitable denning habitat often prevents red foxes from using some areas within the species range of Arctic foxes; however, in the Prudhoe Bay Oilfield red foxes have shown up in recent decades and typically out compete, or kill Arctic foxes. For these reasons, the changes in habitat would most likely have a moderate level of adverse effects on Arctic foxes since some could likely die from red fox predation.

4.3.5.4.5. Alternative 5 (Alternate Gravel Sources)

The effects and levels of effect from Alternative 5 would be the same for Arctic foxes as described for the Proposed Action.

4.3.5.5. Overall Impact Conclusion

As described in more detail above, there are different impacts from the Proposed Action and could affect different terrestrial mammal species in different ways. For example, gravel mining would have a greater effect on grizzly bears and foxes than on other terrestrial mammals such as caribou because of den destruction. Vehicular traffic would most likely affect caribou more than it would grizzly bears and foxes because caribou adults/calves occur in large numbers in the general area and mortalities could occur. The most likely effects from the Proposed Action and action alternatives would be behavioral responses that could range from aversion to flight or aggression, depending upon the species and circumstances. With the assumed mitigation measures as described in Appendix C (see below), overall the Proposed Action would have little or no impact on terrestrial mammals, and thus would have a negligible level of effect.

Mitigation

Appendix C describes mitigation measures derived from lease stipulations, design features and BMPs the operator proposes to commit to, and requirements and BMPs that other agencies typically require (sections C-1 to C-3). BOEM's conclusions regarding impacts assume implementation of, and compliance with, the mitigation measures described in sections C-1 through C-3.

Appendix C (section C-4) also contains additional mitigation measures developed by subject matter experts. Because it is speculative whether or not they would be included in the Proposed Action, consideration of the additional potential mitigation measures is not included in BOEM's analysis of population-level impacts, but the additional measures may be expected to further reduce numbers of terrestrial mammals affected.

4.3.6. Vegetation, Wetlands, and Substrate

This section identifies and discusses impacts associated with the Proposed Action and action alternatives that could impact vegetation and wetlands. As defined by the U.S. Army Corp of Engineers (USACE) wetlands are: "*Those areas that are inundated or saturated by surface or ground water at a frequency and duration sufficient to support, and that under normal circumstances do support, a prevalence of vegetation typically adapted for life in saturated soil conditions. Wetlands generally include swamps, marshes, bogs, and similar areas.*" Wetlands considered "waters of the United States" (WOUS) are under the jurisdiction of the USACE. A complete definition of WOUS is at 40 CFR 230.3. Section 404 of the Clean Water Act requires that a Department of the Army (DA)

permit be obtained for the placement or discharge of dredged and/or fill material into waters of the U.S., including jurisdictional wetlands (33 U.S.C. 1344).

BOEM has incorporated by reference in Appendix E, the Liberty Development Wetland Delineation Report, Foggy Island Bay, Alaska, performed by ASRC Energy Services, Alaska, Inc. (AES) (2015). This wetland and WOUS delineation was performed in accordance with the USACE Wetlands Delineation Manual (Environmental Laboratory 1987) and the Regional Supplement to the USACE Wetland Delineation Manual: Alaska Region (Version 2.0) (USACE, 2007).

4.3.6.1. The Proposed Action

Aquatic Site Assessment and Substrates

Most impacts to wetlands/WOUS from the Proposed Action would occur during construction of the ice roads and pads, gravel mine site development, excavation and backfill for the construction of the offshore pipeline, construction of the landward end of the Liberty pipeline, and construction of the proposed LDPI for the offshore production facilities.

Wetlands discharge activities under USACE jurisdiction are summarized in Table 4.3.7-1. The following activities are subject to Section 404 of the Clean Water Act (CWA):

- Marine water pipeline construction (buried in a trench) in the Territorial Seas (discharge of fill below mean high tide in Beaufort Sea Navigable Waters)
- Onshore pipeline construction of 1.5 miles (2.5 km) of elevated pipeline with Vertical Support Members (VSMs) every 51 ft (15.5 meters (m)) (discharge of fill into jurisdictional wetlands)
- Construction of a 350 ft by 150 ft (106.7 m by 45.7 m) trench (approx. 1.2 acres or 0.40 ha) to accommodate thermosiphons near the pipeline landfall (discharge of fill into jurisdictional wetlands)
- Gravel pad construction (0.71 acre (0.29 ha)) at the Liberty/Badami pipeline junction (discharge of fill into jurisdictional wetlands)
- Pipeline/road crossing pad construction (0.15 acre (0.06 ha)) for a permanent ice road crossing site (discharge of fill into jurisdictional wetlands)
- Development of a 21-acre (8.50 ha) gravel mine site (discharge of fill into jurisdictional wetlands).

The following proposed activities are subject to Section 10 of the Rivers and Harbors Act or Section 404 of the Clean Water Act:

Table 4.3.6-1. Summary of Proposed Impacted Areas under USACE Jurisdiction.

Feature	Acres Covered	Discharge (cy)	Wetlands?	Authority*
LDPI	24	927,000	No	10
Offshore Pipeline	33 (60 ft x 4.5 mi)	394,000	No	404 and 10
Offshore Pipeline	8 (60 ft x 1.1 mi)	97,000	No	10
Transition Pipeline to Shore	1.4 (350 ft x 150 ft)	5,000	Yes	404
Pipeline VSM (170 total)	0.03 (3 ft diam x 170 **)	890	Yes	404
Onshore Road Crossing	0.15 (80 ft x 80 ft)	1500	Yes	404
Badami Tie-in Pad	0.71 (193 ft x 160 ft)	3500	Yes	404

Note: *10 indicates Section 10 of the Rivers and Harbor Act and 404 indicates Section 404 of the Clean Water Act. 10 applies to state waters (territorial seas) and 404 applies to OCS waters.

**VSMs are replaced every 50 ft (15 m) at 20 ft depth.

Ice Roads and Ice Pads

A complete discussion of ice road construction can be found in Section 2.1.1. The Proposed Action includes the construction of a 250 feet ice pad perimeter around the 21-acre gravel mine that would be

used to hold overburden and vegetation for the single year mining season. The ice pad would temporarily impact existing vegetation; crushed vegetation is expected to recover within two growing seasons. Damming of drainages during the spring melt or breakup could interrupt natural sediment flow, and, with a possible concentration of flow, would enhance erosive potential to wetland vegetation and subsequently destabilize substrates. Ice roads and pads may cause delayed plant development (phenology), increasing plant stress, freezing of plant tissues, changed soil chemistry, impacts to soil invertebrates, soil thaw characteristics, and small-scale changes in hydrology and depth of thaw. Yokel et al. (2007) found only minimal evidence of additive impacts from ice roads built over the same route in two subsequent years, and no statistically significant differences in depth of thaw. Guyer and Keating (2005), however, found that long-term vegetation modifications causing repeated delays in vegetation phenology may occur when consecutive-season ice roads are built annually.

Vegetation growing near ice roads could be changed by altered hydrology, with desiccated or flooded nearby habitats. Tussock tundra vegetation could be damaged by annual ice roads which could decrease the wetland's soil temperature regulation leading to thermokarst features (irregular depressions caused by warming, melting, and heaving of frozen ground) that could remove vegetation. Invasive species introduction is possible if imported Proposed Action equipment has not been thoroughly washed.

Effects of ice roads and pads on vegetation and wetlands would be of short duration, local, and limited in extent and is considered to be minor.

Gravel Mine

A complete discussion of the proposed construction of the gravel mine site is provided in Section 2.1.2. Vegetation and overburden would be removed and stockpiled on a 250 foot perimeter ice pad (discussed above) adjacent to the proposed gravel mine site. The footprint of the gravel mine site would be approximately 21 acres and the gravel mined from the site would be hauled directly to the construction sites during the first construction winter.

Excavation of the gravel mine site would remove or disturb wet sedge, moist sedge, dwarf shrub and wet graminoids. All are common in the area.

Gravel mine sites fill with water over time and require dewatering before further use. Water discharged mechanically to nearby areas generally does not have effects on vegetation/wetlands unless discharge rates are uncontrolled, which could result in vegetation loss through erosion.

A 1.5-acre pond is included in the mine site excavation area and would likely be drained. Ponds of this type have a variety of common wetland-dependent plants supporting waterfowl and other types of wildlife. The loss of a small pond due to the excavation of the gravel mine site would be long lasting but localized. The construction of the gravel mine site along with draining of the adjacent pond, results in a minor to moderate loss of local wetland function.

Onshore Gravel Pads and Related Construction

The Proposed Action would result in the discharge of approximately 10,000 cy of gravel fill material into approximately two acres of wetlands and would be a permanent impact.

The habitat most affected by onshore gravel pads and related construction would be dwarf shrub vegetated wetlands with a mix of water regimes: permanently flooded, seasonally flooded, and saturated. Approximately 1.2 acres of moist sedge, dwarf shrub and wet graminoid complex would be lost, and 0.2 acres of other WOUS would be disturbed during construction of the pipeline transition trench.

All of the wetlands north of the Badami Pipeline and the Badami Seasonal Ice Road are pristine, undisturbed, and high functioning (AES, 2015). They are not rare or unique, used for science, or

under threat from upstream sediments or toxins. However, these are high value wetlands because they control erosion, alter flood flows, and provide valuable wildlife habitat, especially for waterfowl and caribou (AES, 2015).

Accidental Oil Spills and Gas Releases

Accidental spills may include gas releases, crude oil spills from the pipeline, or diesel spills from storage tanks, construction equipment, or vehicles and may occur during any of the action alternatives. Gas releases would not impact vegetation and wetlands. The degree of oil spill impacts on vascular plants depends upon a number of abiotic and biotic factors including the type and amount of oil, the plant species and extent of oil coverage, the season of the spill, the weather conditions at the time of the spill, and soil composition. Soil organic matter content is a primary factor controlling the effects of oil spills on wetlands. Large crude oil spills generally can cause widespread impacts to coastal wetland plants, such as reduced plant photosynthesis, transpiration, shoot height, stem density, and biomass, as well as impaired growth and re-growth, and even complete mortality, especially if plant roots are smothered with crude oil.

Small Oil Spills

BOEM assumes about 70 small spills (< 1,000 bbl) would occur over the course of the Proposed Action. The majority of small spills would occur on and be contained on the LDPI or landfast ice (during winter) and not impact the vegetation and wetlands. Coastal habitats in Foggy Island Bay are not likely to be contaminated by small offshore spills, because these spills would disperse quickly during the summer open-water season when coastal vegetation-wetlands might be exposed to the spills.

Small refined oil spills in wetlands and vegetation during summer would likely be from vehicles. Small oil spills of refined products, depending on oil type and amount, may not require extensive clean-up, however, refined oils are toxic if they contact any part of a plant. Small refined oil spills are expected to have negligible to minor local and temporary impacts.

Onshore crude oil spilled from a pipeline rupture impact would vary depending upon various factors, including spill duration, spill volume, contents of spill, size of rupture, control of or lack of flow control, pipeline pressure, winds, and season. A crude oil spill in winter from a buried pipeline and confined to a relatively small area would impact less than an acre of soil. Vegetation affected by a small pipeline spill could be removed and replaced once the contaminated soil was removed and remediated. A crude oil spill under high pressure from an above ground pipeline during windy conditions could kill many acres of vegetation and wetlands during summer, especially if the mixture is under high pressure and sprays over a large area. Overall, a small crude oil spill could result in negligible to moderate impacts to small area of wetland vegetation.

Large Oil Spill

BOEM has analyzed the impacts of one unlikely but reasonably foreseeable large spill during the course of the Proposed Action (see Section 4.1.1.1 for spill assumptions). Large onshore oil spills would impact soils and vegetation, though they are easier to confine and clean up than offshore spills.

Heavy oiling of wet and moist tundra vegetation, wetlands, and other WOUS would kill some plants through fouling, smothering, asphyxiation, and poisoning at the plant roots from direct contact with the oil. Diesel fuel is more toxic than crude oil but would evaporate more quickly and be less persistent than crude oil in the vegetated wetlands and other WOUS. Effects on coastal vegetation-wetland habitat would occur if an offshore spill occurred during summer open water or during spring meltout or if an onshore spill occurred near a riverine system. During winter, bottomfast ice covers the lagoon and coastal shorelines, and snow buffers the tundra from the oil.

Various factors, including spill duration, spill volume, contents of spill, size of rupture, degree of flow control, pressure of pipeline contents, wind conditions, season, and above ground or buried pipeline would affect the adverse impacts to vegetation and wetlands from an onshore large crude oil spill. Moderately oiled wetlands of the Sagavanirktok River east to Mikkelsen Bay would take perhaps 10 years or longer to recover if the oil contaminated both plant surface and subsurface structures during the summer. A large onshore spill could oil up to 5 acres of vegetation along the pipeline landfall to the Badami tie in, causing some ecological harm. Wetland vegetation could also be affected similarly if an off-shore spill occurred and oil and pollutants washed ashore. Oiled vegetation should recover within a few years but may take more than 10 years to fully recover. Overall, a large crude oil spill could result in minor to major impacts on wetlands.

Decommissioning

Rehabilitation of Former Vegetated Wetlands

The minimum project operational life, which includes construction and decommissioning, is estimated to be 25 years. Decommissioning would occur over an 18 month period after production ends. Wetland restoration of areas that were filled during development is not likely, given the long term impacts of the fill and excavation. Restoration would occur along the non-vegetated coast at the landward end of the subsea pipeline. Removal of the gravel pads at the onshore pipeline support at the Badami pipeline tie-in along with removal of VSMs would result in thermokarsting (development of very irregular surfaces of marshy hollows and small hummocks). Restoration of wetland plant communities after gravel removal may be possible in wet tundra areas within about 10 to 30 years from initial restoration efforts but it is unlikely that moist or dry tundra habitats could be restored to conditions similar to natural communities without a greater effort than needed for rehabilitation of wet tundra, if at all. A longer duration for impact recovery would be expected from rehabilitation of wetlands plant communities in mainly moist or dry tundra habitats.

Rehabilitation of Gravel Mine Site

Restoration of the gravel mine site to pre-project conditions is not expected. The topographical difference expected between the bottom of the gravel mine site and adjacent wetlands is so large there is no expectation that a vegetated wetland could be successfully established. Once the gravel for the Proposed Action has been removed (after year 1), the overburden would be returned to the gravel mine site to be rehabilitated. The 15 acres of dwarf shrub vegetation and 4.1 acres of herbaceous vegetation in pre-construction wetlands would be decreased to relatively narrow fringe of wetland vegetation along all or part of the pond/lake shore. Depending upon the design of side-slopes, an emergent wetland fringe may be successfully established along the perimeter of the gravel pit. However, it is anticipated that the area would ultimately resemble an artificial lacustrine system.

Conclusion

Tundra habitats in the Arctic Coastal Plain (ACP) have and will continue to undergo change in response to climatic conditions. Perhaps the most important changes to vegetation in the Arctic environment as a result of climate change are expected in the form of expanding and retreating lakes and wetlands. Much of the ACP is underlain with permafrost. As the current pattern of warming continues, some regions of the Arctic would see shifts in permafrost distribution and deepening of the active layer, accompanied by changes in vegetation and wetlands. Additionally, coastal wetlands are particularly vulnerable to sea level rise associated with increasing global temperature.

The amount of wetlands/WOUS lost during the entire project would be approximately 3-5 acres filled for onshore pads, and approximately 21 acres excavated for the gravel mine. The types of wetlands that would be lost are common in the area. These impacts would be characterized as localized, but long-term. Overall, it is anticipated the impacts of Proposed Action would be result in minor impacts. Appendix C describes mitigation measures derived from lease stipulations, design features and BMPs

the operator committed to, and requirements and BMPs that other agencies typically require (sections C-1 to C-3). BOEM's impacts conclusions assume implementation of, and compliance with, the mitigation measures described in sections C-1 through C-3.

4.3.6.2. Alternative 2 (No Action)

Under this Alternative, the Proposed Action would not be approved and the actions described in the Liberty DPP would not take place. There would be no impacts to vegetation and wetlands.

4.3.6.3. Alternative 3 (Alternate locations for the proposed LDPI)

Alternative 3A: Relocate LDPI Approximately One Mile to the East

The impacts of this Alternative on vegetation and wetlands would be the same as the Proposed Action.

Alternative 3B: Relocate LDPI Approximately 1.5 Miles to the Southwest

The impacts of this Alternative on vegetation and wetlands would be the same as the Proposed Action.

4.3.6.4. Alternative 4 (Alternate Processing Locations)

Alternative 4A: Relocate Oil and Gas Processing to Endicott

The proposed LDPI in the Alternative would require less gravel than the Proposed Action and none of the proposed onshore pads would be needed. The only onshore construction activities needed would be the opening and operation of a new gravel mine site or expansion of an existing gravel mine site, presumably nearer the Endicott SDI. As a result of a smaller LDPI footprint and reduction in onshore pads, impacts to vegetation and wetlands in this Alternative would be reduced slightly from the Proposed Action but still minor.

Alternative 4B: Relocate Oil and Gas Processing to a New Onshore Facility

Additional or expanded gravel pads would be needed for construction of the onshore production facilities in this Alternative. Increased road construction and use would also result to provide access to onshore production facilities. The footprint of the gravel mine site would proportionally increase to provide for this additional construction, though the adding additional losses of vegetation and wetlands would remain less than 10-15 additional acres. Rehabilitation of wetland plant communities after gravel and replacement of wetland habitat would have similar problems as discussed for the Proposed Action. Even with these increases in disturbance, the overall proportion of vegetation and wetlands in the Proposed Action Area that would be impacted by this Alternative remains relatively small. Thus, impacts to vegetation and wetlands from this alternative would be up to moderate.

4.3.6.5. Alternative 5 (Alternate Gravel Sources)

For Alternatives 5A and 5B, vegetation and wetland mapping was performed by AES (2016) and a wetland delineation map for each alternate gravel mine site can be found in Figure 4.3.6-1 and Appendix E. Included in each map is the distribution of *Arctophila fulva*, an herbaceous plant of particular interest to conservation agencies due to its importance as waterfowl habitat. Alternative 5C, Duck Island Mine site, is currently flooded and therefore vegetation and wetland mapping was not performed.

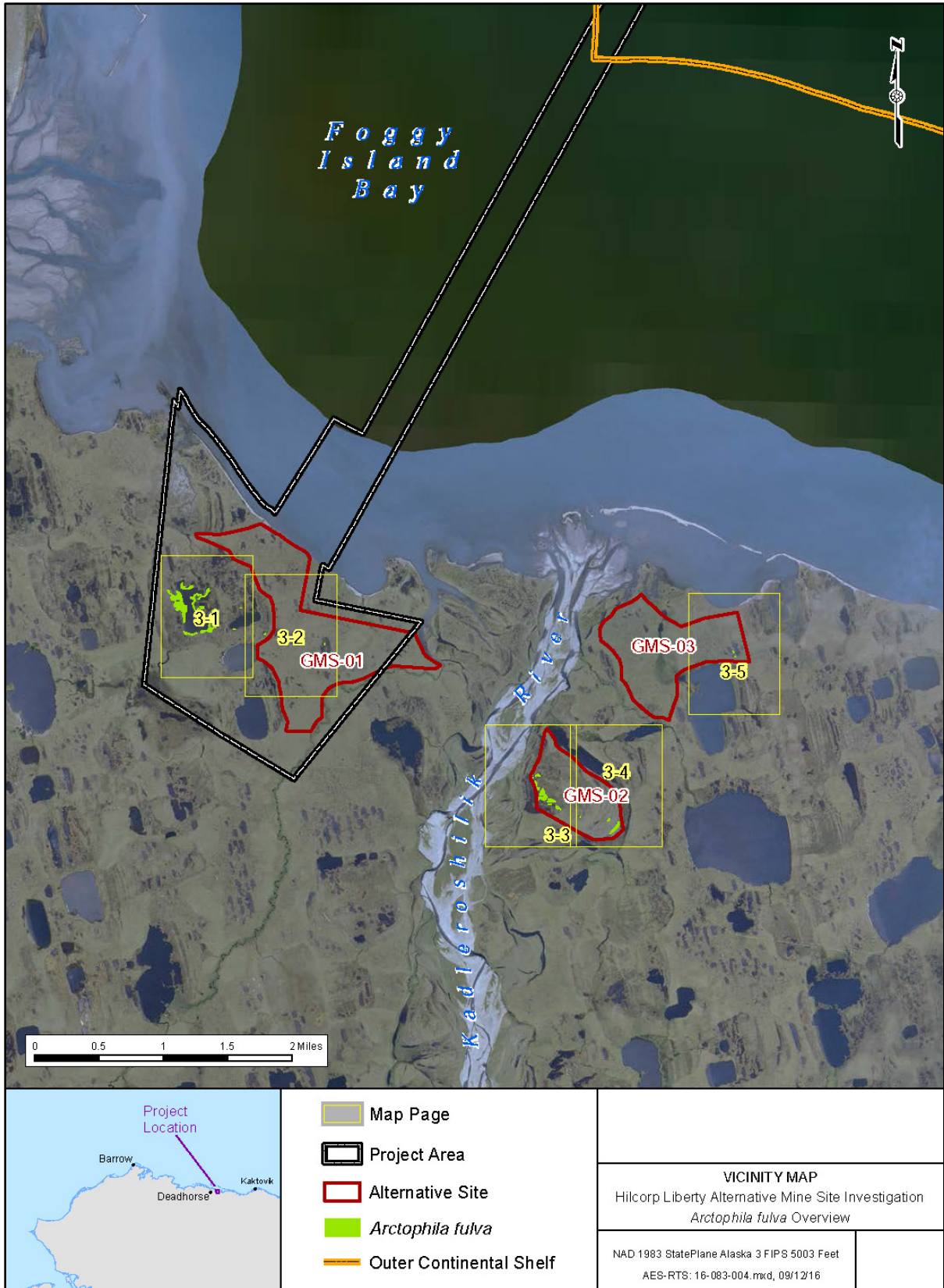

Figure 4.3.6-1. Wetlands Affected and Alternative Mine Sites (AES, 2016).

Table 4.3.7-2 presents the surveyed locations of the Proposed Action, Alternative 5A and Alternative 5B, the amount of area surveyed and the distribution of *Arctophila fulva* in each surveyed location.

Table 4.3.6-2. Comparison of Wetlands and *Arctophila fulva* within the Gravel Mine Site Alternatives.

Category of Measure	GMS-01 MS-01) Proposed Action	GMS-02 MS-02n Alternative 5A	GMS-03 MS-03n Alternative 5B
Wetlands	Lake (6.79 ac) Lower Perennial (0.10 ac) Marine (1.30 ac) PEM (565.63 ac) Pond (20.85 ac)	Lake (9.89 ac) PEM (197.40 ac) Pond (6.53 ac)	Lake (2.55 ac) PEM (350.63 ac) Pond (6.47 ac)
Total Wetlands	594.67 ac	213.82 ac	359.65 ac
<i>Arctophila fulva</i>	Sparse (0.03 ac)	Relatively abundant (5.53 ac)	Sparse (0.07 ac)

Source: AES (2016)

Alternative 5A: East Kadleroshilik River Mine Site #2

The alternate gravel mine site for this Alternative would have two areas: one in similar wetland vegetation as the proposed gravel mine site's wetlands, the other in the main river channels of the Kadleroshilik River. Additional wetlands losses beyond those expected for the Proposed Action would occur. Approximately 0.5 miles of additional ice road would be necessary for this Alternative to provide access from the gravel mine to the Badami Ice Road. Impacts to wetlands and vegetation from this Alternative are similar to those from the Proposed Action; slightly more acreage has the potential to be impacted, and *Arctophila fulva* is more abundant in the overall study site, but overall the level of impacts is expected to be minor.

Alternative 5B: East Kadleroshilik River Mine Site #3

The alternate gravel mine site for this Alternative has similar wetland vegetation as the Proposed Action. Permanent loss of wetlands would occur to construct a channel 4 to 5 times longer than what is needed to connect the proposed gravel mine site to an active flowing body of water. BOEM assumes approximately 1.5 miles of additional ice road would be added for access via the Badami Ice Road and result in additional temporary impacts by crushing more vegetation than the Proposed Action. Impacts to wetlands and vegetation from this alternative are similar to those from the Proposed Action and would be minor.

Alternative 5C: Duck Island Mine Site

This alternate gravel mine site would be an expansion of an existing gravel mine site and would require a new gravel mine area in a braided river channel of the Sagavanirktok River. This new expansion would be equal in size to the Proposed Action's gravel mine site and it is expected to impact an area with similar wetland vegetation as the Proposed Action. A lesser amount of vegetation and wetlands would be impacted in Alternative 5C compared to 5A and 5B. Overall impacts to vegetation and wetlands from this Alternative would be minor.

Conclusion

The impacts of construction of the Proposed Action include destruction of a moderate amount of vegetation in a pristine wetlands complex with other WOUS through the construction of gravel pads, excavation of the gravel mine site and construction of VSMS; and the potential for colonization by non-native, invasive species. These impacts are characterized as long-term on affected vegetation and wetlands. The impacts would be similar among the action Alternatives 3A, 3B, 5A, 5B, and 5C. The greatest vegetation and wetland impacts would result from Alternative 4B resulting in a slight increase in impacts that on vegetation and wetlands compared to the other Alternatives. Though some wetlands and vegetation would be permanently lost as a result of the Proposed Action, given the limited extent of these impacts, the amount of undisturbed wetlands and vegetation in the onshore areas surrounding the Proposed Action, and the pristine condition of these wetlands and vegetation,

overall impacts of the Action Alternatives to wetlands and vegetation are expected to be minor to moderate.

Mitigation

Appendix C describes mitigation measures derived from lease stipulations, design features and BMPs the operator committed to, and requirements and BMPs that other agencies typically require. BOEM's conclusions regarding impacts to vegetation and wetlands assumes implementation of, and compliance with, the mitigation measures described in Appendix C, sections C-1 through C-3. These measures would result in a reduction in overall vegetation and wetlands disturbed by summer tundra travel, by pad maintenance at the edge of permitted gravel fill, and erosion of vegetation and wetlands impacted by flow out of the gravel mine site. These improvements would likely reduce revegetation times for restoration and further reduce the potential for colonization by non-native, invasive species. However, the mitigation measures will not decrease long-term impacts of vegetation and wetland losses at the gravel mine site and by the construction of gravel fill pads.

4.4. Sociocultural Systems

4.4.1. Sociocultural Systems

4.4.1.1. The Proposed Action

This section describes potential effects to sociocultural systems from activities associated with the Proposed Action for Nuiqsut, Kaktovik, and Utqiagvik. Effects could be realized at both the community and borough levels; BOEM describes both here but focusses at the community level.

Sociocultural systems are analyzed with reference to three important components: social organization, cultural values, and formal institutions (Section 3.3.1.2; USDOI, BOEM, 2015). Social organization means how people are divided into social groups and networks. Cultural values reflect the norms and most desirable aspirations and behaviors of people in a society and tend to be widely shared by members of a social group. Formal institutions correspond to the structure and function of local governments, regional and village corporations, nongovernmental organizations.

Potential impacts from the Proposed Action to subsistence activities and sharing networks could compromise social organization. Disturbances to subsistence resources, activities, and harvest patterns could jeopardize important cultural values. Some of the most important cultural values in the North Slope include strong ties to the land and fish and wildlife, care for family, sharing, traditional foods, and independence from institutional and political forces outside the North Slope Borough (NSB).

Changes to the economies, regional or local governments, and/or Alaska Native corporations related to the Proposed Action could affect the structure and function of formal institutions in both adverse and beneficial ways. For example, potential conflicts could occur between and within communities if institutions and organizations develop different views about the Proposed Action. Nuiqsut, Kaktovik, and Utqiagvik are each governed by municipal, tribal, and corporate organizations. Despite close relationships and substantial overlap among the members and leaders of these organizations, it is not uncommon for them to adopt divergent positions with respect to proposed development projects. Disagreements about the Proposed Action and alternatives or how to invest tax revenue from oil and gas development could strain relationships and formal institutions in the NSB. These strains on formal institutions could cause potential failures in social organization.

Sociocultural Systems and Subsistence Practices

The existing sociocultural system can be affected in a negative manner if the primary foundation of the system—subsistence practices—becomes disrupted. Subsistence continues to be the central organizing element of Iñupiaq society, and it is primarily through damage to subsistence resources

and disruptions to subsistence activities and harvest patterns that impacts to the sociocultural system can be assessed. In Nuiqsut, Kaktovik, and Utqiagvik, damage to subsistence resources or disruptions to subsistence activities from the Proposed Action could cause a breakdown in the sociocultural system and the subsistence-cash economy (NOAA, 2016; USDOJ, BOEM, 2015; USDOJ, MMS, 2002). Subsistence harvest practices and sharing networks are a vital part of the mixed economies and cultures of the North Slope (Burnsilver et al., 2016).

Impacts to subsistence harvest patterns and other practices such as sharing subsistence foods may directly translate into impacts to sociocultural systems. Therefore, any components of the Proposed Action that could affect subsistence activities and harvest patterns as described in Section 4.4.3 are relevant to the analysis of effects on the sociocultural system. A summary of potential effects on subsistence harvest patterns is provided in Table 4.4.1-1.

The sociocultural system can be affected in either positive or negative ways if regional economic revenue occurs on a scale sufficient to create substantial local changes in demography, population, employment, prices of commodities, or community prosperity (Picou et al., 2009; Northern Economics, 2006). Potential regional economic effects that could follow from the Proposed Action as described in Section 4.4.2 also are pertinent when discussing potential impacts to sociocultural systems.

Table 4.4.1-1. Summary of Impacts to Subsistence Practices for Nuiqsut, Kaktovik, and Utqiagvik.

Community	Source of Impact ¹	Whaling	Seal hunting	Caribou Hunting	Fishing	Waterfowl Hunting
Nuiqsut	Proposed Action	Moderate to Major	Minor	Negligible	Negligible	Minor
Nuiqsut	Small Spills	Minor to Major	Minor to Moderate	Negligible	Negligible ²	Minor to Moderate
Nuiqsut	Large Spill	Major	Major	Moderate to Major	Moderate to Major	Major
Kaktovik	Proposed Action	Negligible	Minor	Negligible	Negligible	Minor
Kaktovik	Small Spills	Negligible	Minor to Moderate	Negligible	Negligible ²	Minor to Moderate
Kaktovik	Large Spill	Moderate to Major	Minor to Moderate	Minor to Moderate	Moderate	Minor to Moderate
Utqiagvik	Proposed Action	Negligible	Negligible	Negligible	Negligible	Negligible
Utqiagvik	Small Spills	Negligible	Negligible	Negligible	Negligible ²	Negligible
Utqiagvik	Large Spill	Moderate to Major	Minor to Moderate	Minor to Moderate	Negligible	Minor to Moderate

Note: ¹ The Proposed Action includes routine construction, development, production, and decommissioning; a number of small spills (i.e., <1,000 bbl) and one large spill (i.e., ≥1,000 bbl) are assumed to occur during the 25-year life of the Proposed Action.

² BOEM anticipates negligible impacts on subsistence fishing from small spills for Nuiqsut, Kaktovik, and Utqiagvik. However, for subsistence fishers and community residents, stress and negative perceptions of contaminated Arctic cisco, Arctic char, and broad whitefish could be minor to major depending on the location of small spills.

Effects to Sociocultural Systems

BOEM assumes a fundamental importance of subsistence activities to cultural, individual and community health, and well-being. Due to these foundational characteristics, impacts to subsistence activities are considered severe, and thus, major, if they would disrupt subsistence activities, make subsistence resources unavailable or undesirable for use, or only available in greatly reduced numbers for a substantial portion of a subsistence season for any community.

For example, disruptions from the Proposed Action to bowhead whaling and losses of opportunities to harvest whales and other marine resources could have severe and thus major adverse impacts to sociocultural systems in Alaska's North Slope (Pedersen et al., 2000). The Proposed Action could impact the sociocultural system for Nuiqsut, Kaktovik, and Utqiagvik through the following means:

- Loss of opportunities for subsistence harvests (Section 4.4.3)
- Economic revenue (Section 4.4.2)
- Accidental oil spills and spill response and cleanup activities

Loss of subsistence harvests

Long-term loss of subsistence harvests of bowhead whales due to deflection, interference, whaler avoidance, or summer construction at the proposed LDPI could result in severe disruptions to sharing patterns and cultural values. This could create cultural stressors and diminished nutritional status in communities. Long-term loss means for a substantial portion of a subsistence harvest season or more. This in turn could erode or damage social organization and community identity and create stress on local institutions such as health care systems, whaling crew relationships, and annual community feasts.

Activities such as sharing subsistence foods are profoundly important to the maintenance of family ties, kinship networks, and a sense of community well-being. In NSB communities, task groups associated with subsistence harvests are important in defining social roles and relationships. The individuals one cooperates with help define extended family ties, and the distribution of specific tasks reflects and reinforces the roles of family members, friends, and others in their social network. Disruption of these task groups could damage the social bonds that hold the community together. Any moderate to major disruptions of sharing networks have adverse impacts to the subsistence way of life and could trigger fear, anger, and frustration and a sense of loss and helplessness. Because of the psychological importance of subsistence in these sharing networks, perceived threats to subsistence activities are a major cause for anxieties about oil and gas development.

There are three Native allotments in the affected area used by three families and their heirs for subsistence activities. The allotment holders could experience adverse impacts if access to their allotments was prevented or restricted or if subsistence resources were diverted away from their allotments as a result of the Proposed Action. However, any potential effects at the level of the allotments would not result in adverse impacts to sociocultural systems at the borough level.

As described in Section 3.1.6, environmental variability is projected to have many and varying effects in Arctic Alaska in the foreseeable future, and some changes in baseline environmental and social conditions could become more evident. The current environmental conditions in the affected area could change during the 25-year life of the Proposed Action. For example, changes in sea ice can directly affect hunters by changing access and altering the utility of ice as a working surface for subsistence harvest activities such as whale and seal hunting (Huntington, Quakenbush, and Nelson, 2016, p. 3). Sea ice can indirectly affect hunters by altering the distribution, timing, behavior, and local abundance of marine mammals.

Such effects related to environmental variability do not occur in isolation but as a grouping of factors that combine to alter subsistence hunting behaviors and success. For example, subsistence hunters have emphasized that effects on marine mammals and people are the result of interactions among multiple factors, not of changing sea ice alone (Huntington, Quakenbush, and Nelson, 2016). It is therefore difficult to predict how specific changes in the baseline state of sea ice could affect subsistence hunting or the potential impacts of the Proposed Action in 25 years.

BOEM anticipates little to no and thus negligible changes to the potential impacts of the Proposed Action to subsistence activities and harvest patterns and sociocultural systems due to a shifting baseline in environmental conditions. This is because the social and cultural conditions also exist as a shifting baseline. For example, subsistence hunters have been able to adapt to some of these changes by improved equipment and changes in the timing of hunting; moreover, marine mammals appear to be adjusting to a longer open-water period (Huntington, Quakenbush, and Nelson, 2016). BOEM

predicts that the social-ecological system in the North Slope would adapt to shifting environmental conditions over the 25-year life of the Proposed Action.

As described in Section 4.4.3, if anticipated adverse impacts to subsistence harvest patterns were to occur, the highest potential for adverse effects to the sociocultural system would be in the community of Nuiqsut. If moderate to major impacts on Cross Island whaling from summer construction at the proposed LDPI site were realized as anticipated (Section 4.4.3), effects to Nuiqsut's sociocultural system could range from long lasting and widespread but less than severe to severe (i.e., moderate to major).

Impacts to subsistence harvest patterns for Kaktovik and Utqiagvik are anticipated to be less for routine activities associated with the Proposed Action than are anticipated for Nuiqsut. BOEM expects little to no and thus negligible impacts to the sociocultural systems for Kaktovik and Utqiagvik as a result of routine activities associated with the Proposed Action.

Economic revenue

Since 1970, the NSB has experienced substantial growth associated with revenue from oil and gas development, including growth in public services, population, employment in local government, household incomes, and subsistence productivity (Northern Economics, 2006). As discussed in Section 4.4.2, different types of revenue could occur as a result of the Proposed Action (Table 4.4.2-3). The NSB and State of Alaska (SOA) would both receive a share of revenues from property taxes assessed for onshore infrastructure associated with the Proposed Action such as the proposed onshore pipeline. The SOA would gain revenue from corporate income tax and potential royalties from TAPS tariff from OCS volumes. If moderate positive effects on the local economy from increased revenue were to materialize over the 25-year life of the Proposed Action, beneficial effects to sociocultural systems could occur in the NSB.

Subsistence harvesters recognize the benefits brought by oil development, but they also realize that not all potential benefits become realities such as direct employment of NSB residents in industry (SRB&A, 2009). Many residents of the NSB generally hold positive views of increased prosperity and productivity made possible from oil revenues. The main benefits of oil and gas development include corporation dividends, funding for the NSB, employment with the NSB, employment in activities that support industry, training sponsored by industry, use of oil company facilities, and logistical support to whaling crews or search and rescue assistance with oil company equipment (Galginaitis, 2014c; Kruse et al., 1982; SRB&A, 2009). These changes are generally viewed as net benefits of development. If revenue from the Proposed Action created more employment and cash income, NSB subsistence harvesters and their practices could benefit; in turn this could strengthen social organization, cultural values, and formal institutions.

Researchers have documented a positive relationship in North Slope communities between cash income and subsistence harvest and sharing patterns; cash and employment play an integral role within the subsistence way of life (Burnsilver et al., 2016; Kofinas et al., 2016). Households with a source of cash income tend to invest more in subsistence activities and equipment, harvest more wild foods, and provide subsistence food to more households than those without cash incomes. NSB residents have tended to allocate less time for subsistence activities as they increase employment time; yet greater income allows for fuel and equipment purchases that promote more efficient use of time spent engaged in subsistence activities, such as electronics used for navigation, radios used for communication, snowmachines, four-wheelers, and motor boats (Galginaitis, 2014c; USDOJ, BOEM, 2015).

Residents of the NSB have exhibited substantial amounts of local control and self-determination since oil and gas development at Prudhoe Bay (NSB, 1993). The NSB has been able to pioneer many innovative political and legal arrangements related to governance of natural resources. These include

co-management partnerships that direct the use of important natural resources such as bowhead whales and conflict avoidance agreements that reduce or eliminate some impacts of energy development on subsistence harvest patterns and sociocultural systems (Galginaitis, 2014c; Lefevre, 2013; Shadian, 2013).

However, many NSB residents living close to industrial infrastructure are concerned about adverse effects from both energy development and economic growth, including displacement and disruption of fish and wildlife, altered habitat with diminished wildlife stocks, contamination of subsistence food resources, changes in traditional living, emergent social problems, and cumulative adverse effects (SRB&A, 2009, 2013).

Following the experience of development at Prudhoe Bay and adjacent oil and gas fields, social research has documented NSB residents do indeed perceive negative changes in their subsistence way of life. For example, some residents report that industrial sprawl diminishes their cultural sense of solitude and identity with the land. Hunters report that Native allotments, camps, and other sites of cultural significance have been destroyed, looted, or rendered unappealing. Residents are concerned that air pollution from gas flares, small spills, and industrial accidents could contaminate fish and wildlife and impact human health (SRB&A, 2009).

Expanded operations of government, industry, and research in small communities related to oil development can increase public burden and create concern over adverse impacts to social organization and cultural values. Residents of the NSB consistently express concerns about persistent social pathologies, especially substance abuse, domestic violence, and suicide. The potential effects of these social problems on sociocultural systems are reason for concern.

The Proposed Action is expected to have a negligible effect on the population base and a negligible to moderate beneficial impact on the overall economy of the NSB (Section 4.4.2.1). Since little to no increase in population is expected to occur from the Proposed Action, BOEM expects little to no adverse effects to the sociocultural system from population growth. Moderate amounts of increased revenue in the NSB from the Proposed Action (Table 4.4.2-4) could have long lasting and widespread beneficial impacts on sociocultural systems for Nuiqsut, Kaktovik and Utqiagvik. BOEM anticipates that potential increased revenue from the Proposed Action would cause little to no adverse impacts to the sociocultural system because the additional revenue is estimated to be relatively small; the annual increase in revenues would be less than one percent (Section 4.4.2.1).

Oil spills and spill response

Small oil spills have the potential to impact sociocultural systems by affecting subsistence harvest patterns (Section 4.4.3; Table 4.4.1-1). Subsistence harvesters could purposively reduce their harvests of a particular subsistence food resource due to pervasive fears of contamination. Loss of opportunities to harvest could result from either perceived or actual contamination. This in turn affects the cultural and spiritual practice of harvesting and the social and nutritional practice of sharing. A small spill of crude or refined oil could have adverse effects on cultural values and social organization. If minor to major effects from small spills to subsistence harvest patterns were to occur, BOEM anticipates minor to major effects to the sociocultural system in Nuiqsut.

For small spills, BOEM generally anticipates little to no impacts to sociocultural systems for Kaktovik and Utqiagvik. For Kaktovik, however, small spills of crude or refined oil could have minor to moderate effects on subsistence seal hunting and waterfowl hunting (Table 4.4.1-1). If these impacts to subsistence harvests were realized due to a small spill, social organization and cultural values could be adversely affected in Kaktovik because of the importance of seals, geese, and eiders in traditional practices; impacts to the sociocultural system could be minor to moderate if hunters were present at the location of the spill when it occurred.

Effects from a large oil spill on the sociocultural systems of local communities could come from oiling of habitats and subsistence resources, spill response and cleanup activities, changes in population, employment, and income, and social and psychological stress due to fears of a potential spill tainting food resources (Palinkas et al., 1993). Effects from a large spill could disrupt ongoing sociocultural systems by disturbing the cultural and nutritional practice of subsistence harvesting and sharing for one or more seasons. This would impede sharing harvested resources with those residing in the community and those outside the community who rely on receiving subsistence foods to maintain their cultural values and identities. This is especially the case for many Iñupiat elders who no longer hunt and fish for themselves.

Effects from a large oil spill could result in a loss of or reduction in traditional whaling practices. If subsistence whaling areas are contaminated by an oil spill, or if hunters are unable to use traditional whaling areas, the sociocultural system could be severely impacted. In the unlikely event of a large oil spill, severe and thus major impacts could occur to Cross Island whaling, which would translate to major impacts to the sociocultural system in Nuiqsut.

In the unlikely event of a large spill, moderate to major impacts are expected to occur for whaling for Kaktovik and Utqiagvik crews (Table 4.4.1-1). In turn, a large spill could have moderate to major effects on the sociocultural systems of Kaktovik and Utqiagvik depending on the extent of oiling of their whaling and seal hunting areas. If any part of the bowhead migration area outside their primary whaling areas was contacted by oil in the event of a large spill, impacts to sociocultural systems could be widespread and thus would be considered moderate for Kaktovik and Utqiagvik, primarily due to perceived tainting of bowhead whales as a food source. BOEM expects severe and thus major impacts on sociocultural systems lasting more than one year for Kaktovik and Utqiagvik if their core bowhead whaling areas were directly contacted by oil in the event of a large spill. Effects in social and institutional organizations and the local economy can occur due to local employment in spill response and cleanup activities. A sudden employment increase could have adverse effects, including inflation and displacement of Alaska Native residents from subsistence harvest activities. Employment of local Iñupiat could alter subsistence practices and put stresses on day-to-day life in the communities by drawing local workers away from village service jobs (Palinkas et al., 1993). Over longer duration, a large spill and cleanup activities could cause social relations and cohesion in communities to deteriorate (Palinkas et al., 1993; USDOJ, BOEM, 2015), especially if differential or inequitable increases in local income occur from temporary employment in oil spill response and cleanup (Wooley, 1995).

However, a large spill is expected to have a negligible impact on local revenues and economy (Section 4.4.2.1). The effects on the local economy would depend on the extent to which local residents are employed in cleanup work and would most likely be negligible to minor due to the temporary nature of spill response and cleanup jobs (Section 4.4.2.1). Local population effects are likely to be negligible due to the temporary nature of the jobs, physical separation of worker housing from community residents, and low likelihood of cleanup workers permanently relocating to the NSB (Section 4.4.2.1). Because of these expected economic effects, BOEM expects spill response and cleanup to have a negligible to minor impact on sociocultural systems.

Government initiated unannounced exercises (e.g., oil spill drills), which are infrequent, of short duration, (<8 hours), and utilize existing equipment, would not alter impact conclusions for sociocultural systems.

Conclusion

Appendix C describes mitigation measures derived from lease stipulations, design features and BMPs the operator committed to, and requirements and BMPs that other agencies typically require (sections C-1 to C-3). BOEM's conclusions regarding impacts assume implementation of, and compliance with, the mitigation measures described in sections C-1 through C-3.

The primary subsistence activity that could be adversely affected by the Proposed Action is bowhead whaling conducted by crews from Nuiqsut (Table 4.4.1-1). A large spill of crude or refined oil associated with the Proposed Action could have major adverse impacts to subsistence whaling, seal hunting, and waterfowl hunting for Nuiqsut (Table 4.4.1-1). If moderate to major impacts on Cross Island whaling from summer construction at the proposed LDPI site were realized as anticipated (Section 4.4.3), effects to Nuiqsut's established system of social organization, cultural values, and formal institutions could be moderate to major. If minor to major effects from small spills to subsistence harvest patterns are realized as anticipated, BOEM anticipates minor to major effects to occur to the sociocultural system for Nuiqsut. If major impacts from a large spill occur to Cross Island whaling as anticipated, BOEM expects severe and thus major impacts to occur for the sociocultural system in Nuiqsut.

Impacts to subsistence harvest patterns for Kaktovik and Utqiagvik are anticipated to be less for routine activities and small spills associated with the Proposed Action than are anticipated for Nuiqsut. BOEM expects negligible impacts to the sociocultural systems for Kaktovik and Utqiagvik as a result of routine activities associated with the Proposed Action. For small spills, BOEM generally anticipates negligible impacts to sociocultural systems for Kaktovik and Utqiagvik. For Kaktovik, however, small spills of crude or refined oil could have minor to moderate effects on subsistence seal hunting and waterfowl hunting (Table 4.4.1-1). If these impacts to subsistence harvests were realized due to a small spill, social organization and cultural values could be adversely affected in Kaktovik because of the importance of seals, geese, and eiders in traditional practices; impacts to the sociocultural system could be minor to moderate if hunters were present at the location of the spill when it occurred.

In the event of a large spill, moderate to major impacts are expected to occur for whaling for Kaktovik and Utqiagvik crews (Table 4.4.1-1). In turn, a large spill could have moderate to major effects on the sociocultural systems of Kaktovik and Utqiagvik depending on the extent of oiling of their whaling and seal hunting areas. The chance of contact of oil from a large spill for the whaling areas of Kaktovik and Utqiagvik is less than 5% during January through December (Table 4.7.9-1 and Appendix A). If any part of the bowhead migration area outside their primary whaling areas was contacted by oil in the event of a large spill, impacts to sociocultural systems could be widespread and thus would be considered moderate for Kaktovik and Utqiagvik, primarily due to perceived tainting of bowhead whales as a food source. BOEM expects severe and thus major impacts on sociocultural systems lasting more than one year for Kaktovik and Utqiagvik if their core bowhead whaling areas are directly contacted by oil in the event of a large spill.

As described in Chapter 3, global climate change could alter current conditions in the Proposed Action Area during the 25-year life of the Proposed Action. BOEM does not anticipate, in this relatively short timeframe, climate change would alter the impacts of the Proposed Action to sociocultural systems as described in Chapter 4.

4.4.1.2. Effects of Alternative 2 on Sociocultural Systems

Under Alternative 2, potential impacts on subsistence activities and harvest patterns from disruptions to hunting and fishing and actual or perceived contamination of subsistence foods associated with the Proposed Action would not occur. There would be no impacts on subsistence harvest patterns for Nuiqsut, Kaktovik, and Utqiagvik. Therefore, there would be no adverse impacts to sociocultural systems under Alternative 2. There would be no new economic growth or tax revenue in the NSB from the Proposed Action under Alternative 2. The communities of Nuiqsut, Kaktovik, and Utqiagvik would experience no sociocultural benefits from the Proposed Action under Alternative 2.

4.4.1.3. Effects of Alternative 3 on Sociocultural Systems

In Alternative 3, the proposed LDPI would be relocated (Section 2.2.4). Alternative 3A would relocate the proposed LDPI one mile to the east into deeper water, and Alternative 3B would relocate the proposed LDPI 1.5 miles to the southwest into slightly shallower waters managed by the SOA.

For both Alternative 3A and 3B, the proposed LDPI would remain in the southern portion of Nuiqsut's bowhead whaling area. Alternatives 3A and 3B would not change the potential likelihood or severity of whaler avoidance of the Proposed Action Area or negative perceptions of tainted subsistence resources and general avoidance of industrial developments while subsistence hunting and fishing.

Alternative 3A could prolong potential impacts to the sociocultural system through loss of subsistence opportunities for Nuiqsut. Prolonged impacts could occur if construction activities were extended into the fall whaling season for Nuiqsut and into a second summer construction season and hence a second whaling season. Under 3A, effects to whaling for Nuiqsut from summer construction activities at the proposed LDPI would remain major (Section 4.4.3.1) but could be prolonged into a second whaling season, which could have severe and thus major impacts on the sociocultural system in Nuiqsut. This increase in summer construction time could also increase impacts on subsistence seal hunting from minor to moderate for Nuiqsut and Kaktovik, potentially increasing impacts to social organization and cultural identity in these villages. These impacts would be realized by disruptions to sharing practices and sharing networks and losses in opportunities to transmit traditional knowledge and practice from experienced harvesters to younger up-and-coming whalers and seal hunters.

If Alternative 3B allowed summer construction at the LDPI to cease by August 25, impacts to whaling for Nuiqsut from LDPI slope protection work could be reduced from major to moderate. If Alternative 3B allowed summer construction at the proposed LDPI to cease by July 25, impacts to whaling for Nuiqsut from LDPI slope protection work could be reduced from major to negligible. This change could also reduce potential impacts to subsistence seal hunting from minor to negligible for Nuiqsut and Kaktovik hunters. If summer construction activities at the proposed LDPI were ceased by July 25, the Proposed Action would most likely have little to no effects to sociocultural systems.

Alternative 3B would move the proposed LDPI and operations into waters managed by the SOA, which would substantially increase property taxes (Section 2.2.4). Some of the increased revenue to the SOA from Alternative 3B could benefit the NSB communities. Added revenue income to the NSB could benefit individual subsistence harvesters. Increased revenue under Alternative 3B could have a minor beneficial effect on the local economy (Section 4.4.2), which could translate to a short term and localized beneficial effect to the sociocultural system.

Conclusion for Alternative 3A: Most impacts of Alternative 3A on sociocultural systems would be the same as those for the Proposed Action (Section 4.4.1.1) with the exception of potential effects of summer construction on whaling and seal hunting. Potential effects on whaling for Nuiqsut from summer construction activities at the proposed LDPI would remain major but could be prolonged into a second whaling season, which could increase the duration and likelihood of severe impacts to the sociocultural system for Nuiqsut. Impacts to subsistence seal hunting from prolonged summer construction work (i.e., proposed LDPI slope protection) would extend potential impacts into a second seal hunting season, thereby increasing effects to seal hunting from minor to moderate, which could prolong impacts to the sociocultural system. If these impacts to subsistence were extended into a second open-water season under Alternative 3A, BOEM anticipates overall effects to the sociocultural system from losses of subsistence opportunities would be moderate to major.

Conclusion for Alternative 3B: Most impacts of Alternative 3B on sociocultural systems would be the same as those for the Proposed Action (Section 4.4.1.1) with the exception of potential effects of

summer construction on whaling and seal hunting. If summer construction at the proposed LDPI ceased by August 25, impacts to whaling for Nuiqsut from LDPI slope protection work could be reduced from major to moderate. If summer construction at the proposed LDPI ceased by July 25, impacts to whaling for Nuiqsut from LDPI slope protection activities could be reduced from major to negligible. This change could also reduce potential impacts to subsistence seal hunting from minor to negligible for Nuiqsut and Kaktovik. Reducing summer construction time at the proposed LDPI would most likely reduce impacts to sociocultural systems, especially for Nuiqsut. Alternative 3B could have negligible to moderate adverse impacts to the sociocultural system for Nuiqsut and Kaktovik.

Under Alternative 3B, if increased tax revenue was provided to the NSB as a result of moving the proposed LDPI into state-managed waters, subsistence harvesters in Nuiqsut, Kaktovik, and Utqiagvik could benefit. This would most likely have a short term and localized and thus minor beneficial effect to the sociocultural system of the North Slope.

4.4.1.4. Effects of Alternative 4 on Sociocultural Systems

Under Alternative 4, oil and gas processing would be relocated to one of two alternate facilities (Section 2.2.5). Alternative 4A would relocate oil and gas processing activities to Endicott located to the west of the Proposed Action Area. Alternative 4B would relocate oil and gas processing to a new onshore facility that would need to be built near the Badami pipeline tie-in point.

Both Alternative 4A and 4B would reduce the construction time for the proposed LDPI, perhaps by as much as 20 days. Decreasing summer construction activities at the proposed LDPI related to LDPI slope protection could reduce impacts to whaling and thus sociocultural systems.

Alternatives 4A and 4B would most likely reduce the overall noise produced at the proposed LDPI. All power for both the onshore and offshore facilities would be generated onshore, further reducing noises offshore at the proposed LDPI site. Overall, BOEM does not anticipate any added advantage or reduced impact to sociocultural systems from this reduction in offshore noise. However, substantial reduction of noise at the proposed LDPI would most likely reduce impacts to Cross Island whalers and other residents of Nuiqsut associated with their knowledge and experience of how noise in the marine environment decreases whaling success. Moving oil and gas processing to Endicott or onshore at the Badami tie-in site would most likely decrease negative perceptions of noise in the marine environment that whalers associate with deflection of the whale migration and lower success in whaling. Reducing or eliminating the pervasive fear of noise in the marine environment would most likely bolster cultural identity, local cultural values, and overall community well-being and thus could benefit sociocultural systems, especially in Nuiqsut.

Both Alternatives 4A and 4B would increase tax revenue for the SOA and the NSB. If increased tax revenue was provided to the NSB as a result of moving the processing to Endicott or building a new processing facility at the Badami pipeline tie-in site, subsistence harvesters in Nuiqsut, Kaktovik, and Utqiagvik could benefit, and the sociocultural system of the North Slope could experience short term minor and beneficial effects from increased revenue and economic growth.

Conclusions for Alternatives 4A and 4B: Most impacts of Alternatives 4A and 4B on sociocultural systems would be the same as those for the Proposed Action (Section 4.4.1.1). However, decreasing the time needed for summer construction activities at the proposed LDPI for LDPI slope protection could reduce impacts to whaling for Nuiqsut, depending on when summer construction ceased. This change could also reduce potential impacts to subsistence seal hunting for Nuiqsut and Kaktovik hunters. These potential benefits to subsistence would most likely reduce impacts to sociocultural systems. Moving oil and gas processing to Endicott or onshore near the Badami tie-in point would most likely decrease negative perceptions of noise in the marine environment and potential deflection of the whale migration farther offshore. This would most likely improve overall community well-

being by reducing stress associated with negative perceptions of noise. Increased tax revenue could result in minor beneficial effects to sociocultural systems related to economic growth. Overall, BOEM anticipates Alternatives 4A and 4B would have negligible to moderate effects to the sociocultural system for Nuiqsut and Kaktovik because of reduced loss of subsistence opportunities. BOEM anticipates minor beneficial effects to the sociocultural system for the NSB from Alternatives 4A and 4B.

4.4.1.5. Effects of Alternative 5 on Sociocultural Systems

Alternative 5 would relocate the proposed gravel mine (Section 2.2.6). There are three alternate mine sites, including two new sites, Alternatives 5A and 5B, east of the Kadleroshilik River and Alternative 5C, the existing Duck Island mine site on Endicott Road in the Sagavanirktok River Delta.

BOEM anticipates that impacts from Alternatives 5A and 5B on sociocultural systems would be essentially the same as impacts described for the Proposed Action (Section 4.4.1.1).

Alternative 5C would most likely increase construction time for the proposed LDPI, possibly into a second season. This would prolong adverse impacts to subsistence whaling for Nuiqsut and seal hunting for Nuiqsut and Kaktovik. This could prolong potential impacts to sociocultural systems for these communities.

Conclusion for Alternatives 5A and 5B: Impacts from Alternatives 5A and 5B to sociocultural systems would be the same as the Proposed Action, which are moderate to major for Nuiqsut and negligible for Kaktovik and Utqiagvik (Section 4.4.1.1).

Conclusion for Alternative 5C: Most impacts of Alternative 5C on sociocultural systems would be the same as those for the Proposed Action (Section 4.4.1.1) with the exception of potentially prolonging effects of summer construction activities on bowhead whaling and seal hunting. This would most likely have moderate to major adverse impacts to the sociocultural system in Nuiqsut. For Kaktovik, adverse effects to the sociocultural system could increase from negligible to minor from loss of subsistence opportunity.

4.4.2. Economy

4.4.2.1. The Proposed Action

The primary factors for calculating the economic effects of the Proposed Action are employment, labor income (wages), population, revenues, and oil spills. The effects analysis is relative to the baseline description of the existing economic conditions described in Section 3.3.2. All of the projections that BOEM presents in this section are approximate.

Increases in employment, labor income, and revenues are considered positive or beneficial effects. Increases in population are generally considered positive; however, there could be some adverse secondary considerations associated with large percentage population increases at the local level (e.g., inflation, strains on existing public and social infrastructure, etc.). Oil spills can have both beneficial and adverse impacts on employment, labor income, and revenues depending on the characteristics of the spill and the industries / sectors of the economy that are affected. The size of an oil spill is a key variable in determining potential economic impacts. BOEM uses three categories of spills, including small, large, and VLOS. Small spills of crude or refined oil (i.e., <1,000 bbl) are accidental events that have occurred with general routine frequency and are assumed to occur from the Proposed Action during its lifetime. Although an unlikely event, one large spill of crude or refined oil (i.e., ≥1,000 bbl) is assumed to occur during the development and production phase of the Proposed Action. The potential effects of small and large oil spills on the State of Alaska (SOA) and NSB economies are examined in this section, while the potential effects of a VLOS are examined in Section 4.7.9.3.

BOEM characterizes beneficial and adverse effects that would occur for a limited time during individual phases of the project (such as construction and development), or for a longer duration (such as the production phase or lifetime of the project) to better understand the relative magnitude and duration of the effects on the SOA and NSB economies. BOEM includes some relevant information on the positive effects of the Proposed Action at the Federal level for informational purposes even though the impact analysis focuses on the SOA and the NSB given the relative size of the Liberty project relative to the U.S. economy.

Methodology for Employment, Labor Income, and Revenues

Definitions

Section 3.3.2.1 describes baseline data and information on NSB and SOA employment and labor income (wage) data. The following definitions apply to the analysis of economic impacts: “direct employment” includes those workers with jobs directly in oil and gas exploration, development, production, and decommissioning; “indirect employment” includes those workers in industries that support the direct oil and gas activities (e.g., jobs in transportation, such as shuttling workers by air between Anchorage and the North Slope); “induced employment” is the aggregate of workers associated with providing goods and services to direct and indirect workers; and “labor income” refers to wage compensation generated by direct, indirect, and induced employment.

The direct changes in employment, income, and expenditures resulting from the Proposed Action would initiate subsequent rounds of income creation, spending, and re-spending. Third-party contractors, vendors, and manufacturers receiving payment for goods and/or services required by the Proposed Action would, in turn, be able to pay others who support their businesses. In addition, persons directly and indirectly employed as a result of the Proposed Action would generate additional jobs and income in the economy as they purchase goods and services. These indirect and induced effects are also referred to as “multiplier effects.”

Framework for Employment, Labor Income, and Revenue Analysis: MAG-PLAN Alaska Model

The following analysis incorporates results from MAG-PLAN Alaska. MAG-PLAN Alaska (Northern Economics, Inc. et al, 2012) is a 2-stage, region-specific economic impact model used by BOEM to quantify potential economic impacts (direct, indirect, and induced) of oil and gas development in the Alaska OCS planning areas. Stage 1 estimates the level and allocation of direct expenditures as well as direct manpower requirements and government revenues resulting from OCS oil and gas activities specified in an exploration and development (E&D) scenario. Stage 2 involves projecting the indirect and induced economic impacts of the OCS activities on potentially affected regions in Alaska, including the NSB. The model requires an E&D scenario for a specified modeling area or project as an input; model results are scenario-specific.

MAG-PLAN Alaska has evolved through the years in response to BOEM’s analytical needs and in response to changing economic conditions and technological trends in oil and gas development. The current version (Northern Economics et al., 2012) contains the state of knowledge on new technologies, industry costs, and manpower requirements for various offshore exploration, development, and production activities in the Beaufort Sea and Chukchi Sea Planning Areas of the Alaska OCS. The current version was modified and run with Liberty scenario-specific data, including information on proposed infrastructure, timing of activities, number of development and production wells, and production volumes. Summary of the MAG-PLAN output was provided to BOEM and is presented in the Liberty EIA (Hilcorp, 2015, Appendix A). The data presented in this section comes directly from the summary MAG-PLAN Alaska output.

Table 4.4.2-1 Estimated Employment for the Proposed Action by Project Phase provides information on the direct, indirect, and total jobs supported by the Proposed Action in the NSB and SOA. Due to

the small size of the project and resulting employment projections, BOEM chose not to round model output for presentation in tables and text. However, these estimates should be interpreted as a relative measure of jobs that would be needed to support the various project stages - not that the model has a level of precision indicated by the unrounded results.

The MAG-PLAN Alaska model output also includes estimates of potential royalty payments, lease payments, “TAPS effect,” SOA corporate income taxes, and property taxes related to onshore infrastructure that would likely be generated by the Liberty Proposed Action scenario. Oil produced from the Proposed Action would help keep flow capacity up in TAPS and reduce the pipeline tariff, a situation that would increase revenue to the SOA from royalties and production tax (the “TAPS effect”).

For purposes of this analysis, BOEM assumes a price of \$100 per barrel of oil. Historically, oil prices are volatile: \$132/bbl in June 2008; \$40/bbl in December 2008; \$125/bbl in March 2012; \$30/bbl in January 2016; and \$53/bbl in December 2016 (EIA, 2016). Despite the downturn in prices in 2015 and 2016, the U.S. Energy Information Administration in its Annual Energy Outlook 2017 projects a price of about \$95/bbl in 2030 (in 2016 dollars) and a continued increase to \$110/bbl prior to 2040 (EIA, 2017). The start of Liberty production is likely to begin around 2026 (see Table 4.4.2-1), making the \$100/bbl assumption over a period of 25 years of production reasonable.

Total oil production from the Proposed Action is anticipated to be 90 to 130 million barrels) for an estimated value of \$9 to \$13 billion (Hilcorp, 2015, Appendix A).

Employment and Labor Income

The Proposed Action would support direct jobs during project pre-development, development, production/operations, and abandonment phases. The projected number of workers needed is greatest during the 4-year development phase (construction and drilling) and fewer during the other phases (see Tables 4.4.2-1 through 4.4.2-4). BOEM uses the projected peak annual number of jobs over the life of the project and associated labor income (wages) relative to the 2015 baseline in Section 3.3.2.1 to analyze the maximum likely effects of the Proposed Action in any given year; impacts at this level would be short-term. BOEM also considers the average annual employment and labor income associated with the production phase (approximately 25 years long) in evaluating the average longer term impacts of the Proposed Action.

The nature of oil and gas employment is such that the MAG-PLAN employment estimates do not translate directly to the number of new workers needed. A portion of the estimates represent the continuation of existing jobs as previous projects are completed and workers cycle to the Liberty project, and in effect are not “new;” and a portion represent “new” part-time jobs but in effect would result in more work hours for already employed workers.

Table 4.4.2-1. Annual Average Employment (Number of Jobs)¹ by Project Phase.

Liberty Scenario Phase	NSB Direct Employment	Other Alaska Direct Employment ¹	Other U.S. Direct Employment ¹	NSB Indirect and Induced Employment ¹	Other Alaska Indirect and Induced Employment ¹	NSB Total ² Employment ¹	Other Alaska Total ² Employment ¹
Pre-Development	0	137	169	0	75	0	212
Development	26	875	665	16	1,723	41	2,599
Production	6	129	132	6	350	12	479
Abandonment	9	108	421	4	113	14	221

Note: Estimated annual average employment to support the Proposed Action by project phase.

¹Jobs include part-time, seasonal, and full-time. ²NSB and other Alaska totals are the sum of direct, indirect and induced jobs presented in this table. Totals presented may differ due to rounding.

Source: MAG-PLAN Alaska summary output.

Table 4.4.2-2. Peak/Maximum Employment by Community and Project Phase.

Liberty Scenario Phase	NSB Direct Employment	Other Alaska Direct Employment ¹	Other U.S. Direct Employment ¹	NSB Indirect and Induced Employment ¹	Other Alaska Indirect and Induced Employment ¹	NSB Total ² Employment ¹	Other Alaska Total ² Employment ¹
Pre-Development	0	314	411	0	172	0	486
Development	47	1,863	1,102	25	3,527	73	5,389
Production	6	235	253	7	882	14	1,117
Abandonment	9	108	421	4	113	14	221

Note: Estimated Employment to Support the Proposed Action by Project Phase.

¹jobs include part-time, seasonal, and full-time; ²NSB and other Alaska totals are the sum of direct, indirect and induced jobs presented in this table. Totals presented may differ due to rounding.

Source: MAG-PLAN Alaska summary output provided to BOEM. Notes:

Table 4.4.2-3. Annual Average Employment Labor Income by Community and Project Phase¹.

Liberty Scenario Phase	NSB Direct	Other Alaska Direct	Other U.S. Direct	NSB Indirect and Induced	Other Alaska Indirect and Induced	NSB Total ²	Other Alaska Total ²
Pre-Development	0	13	16	0	3	0	16
Development	1	51	53	1	118	2	169
Production	1	12	12	1	24	2	37
Abandonment	0	8	10	0	8	1	16
Total Project Lifetime	18	593	610	18	1,140	37	1,733

Notes: ¹Estimated Annual Average Labor Income (Millions of 2015\$) Associated with Employment by Community and Project Phase.

²Local and other Alaska totals are the sum of direct, indirect and induced presented in the table. Totals presented may differ due to rounding.

Labor income values were inflated from 2013\$ to 2015\$ using the U.S. Department of Labor, Bureau of Labor Statistics Consumer Price Index-urban (CPI-U) for Anchorage (USDOL, BLS, 2017a).

Source: MAG-PLAN Alaska summary output provided to BOEM. Notes:

Table 4.4.2-4. Peak/Maximum Employment Labor Income by Community and Project Phase¹.

Liberty Scenario Phase	NSB Direct	Other Alaska Direct	Other U.S. Direct	NSB Indirect and Induced	Other Alaska Indirect and Induced	NSB Total ²	Other Alaska Total ²
Pre-Development	0	20	39	0	8	0	37
Development	2	96	88	2	189	4	285
Production	1	14	14	1	60	1	74
Abandonment	0	8	10	0	8	1	16
Total Project Lifetime	18	593	610	18	1,140	37	1,733

Notes: ¹Estimated peak labor income (millions of 2015\$) associated with employment by community and project phase.

²Local and other Alaska totals are the sum of direct, indirect and induced presented in the table. Totals presented may differ due to rounding.

Labor income values were inflated from 2013\$ to 2015\$ using the U.S. Department of Labor, Bureau of Labor Statistics CPI-U for Anchorage (USDOL, BLS, 2017a).

Source: MAG-PLAN Alaska summary output provided to BOEM. Notes:

State of Alaska Employment and Labor Income

BOEM estimates that the peak annual employment effects in other Alaska (not including the NSB) associated with the Proposed Action would occur during development with 5,389 total jobs (1,863 direct jobs and 3,527 indirect and induced jobs). The associated total peak annual labor income would be approximately \$285 million in 2015 dollars. The incremental impact of the peak total annual jobs would represent less than one percent of total Alaska employment in 2015. Correspondingly, the incremental impact of the associated peak annual labor income in 2015 dollars would be less than one percent of Alaska wages in 2015. Once production begins, the average annual direct jobs in other

Alaska are projected to be about 129 over a 25-year period; average annual total employment (direct, indirect, and induced) during this production phase is projected to be approximately 479 jobs. The relatively small number of annual jobs and associated labor income associated with the Proposed Action would have little to no effect on the SOA economy, resulting in a negligible effect.

However, it is worth noting that the Proposed Action would generate approximately \$1.7 billion in labor income in the SOA and \$1.2 billion in the U.S. over the life of the Proposed Action. A negligible impact finding does not diminish this potential contribution.

NSB Employment and Labor Income

BOEM estimates that the peak annual NSB employment effects associated with the Proposed Action would occur during development with approximately 73 total jobs (47 direct jobs and 25 indirect and induced jobs) and an associated labor income of \$4 million. The incremental impact of the peak total annual jobs estimate and associated labor income would represent 2.2% and 2.6% of total NSB employment and NSB wages in 2015, respectively. However, for reasons discussed in the introduction to this section, fewer of these jobs are likely to represent new workers and the likely impact on NSB jobs and wages from the Proposed Action would be smaller. Once production begins, the average annual direct jobs in the NSB are projected to be about 6 over a 25-year period; average annual total employment (direct, indirect, and induced) during this production phase is projected to be approximately 12 jobs. Historically the oil industry employs few village residents; participation by Borough residents would likely remain comparatively low in oil industry-related jobs on the North Slope over the life of the Proposed Action.

The relatively small number of annual jobs and associated labor income over the pre-development, production, and abandonment stages of the Proposed Action would have little to no effect on the economy of the NSB. The somewhat larger (but still relatively small) number of annual jobs and associated labor income during development are also likely to have little effect on the economy of the NSB; however, more noticeable short-term positive effects could occur if more of the employment estimates for development represent new full-time jobs. Thus, the Proposed Action is expected to have a negligible to minor effect on the NSB economy over the life of the Proposed Action.

Revenues

Table 4.4.2-5 presents MAG-PLAN estimates of Federal, SOA, and NSB revenue streams likely to be generated by the Proposed Action. BOEM analyzes the potential incremental effects by comparing revenues generated from the Proposed Action relative to the current (baseline) SOA and NSB revenues described in Section 3.3.2.2.

Table 4.4.2-5. Federal, SOA, and NSB Revenues (Millions of 2015\$)¹.

Revenue Source	Total	Annual Average
Total Federal Royalties and Lease Payments Collected	1,479.7	37.9
Federal Share of Royalties and Lease Payments	1,080.2	26.6
SOA Share of Federal Royalties and Lease Payments	399.5	9.8
TAPS Effect	116.0	3.0
State Corporate Income Tax	15.4	0.4
Total Property Tax Collected	38.0	1.0
SOA Share of Property Taxes	2.9	0.1
North Slope Borough Property Taxes	35.2	1.1

Notes: ¹Estimated Federal, SOA, and NSB Revenues Generated by the Proposed Action
Modeling was based on the following assumptions: total oil production of 117 million barrels from the Proposed Action; 12.5% royalty rate; 27% for Section 8(g) SOA share of royalty; 2% for property tax (20 mills); revenue values were inflated from 2013\$ to 2015\$ using the U.S. Department of Labor, Bureau of Labor Statistics consumer price index inflation calculator (USDOL, BLS, 2017b).

Source: MAG-PLAN Alaska summary output.

State of Alaska Revenues

On average, the SOA would receive \$9.8 million annually associated with its share of royalties and lease payments. BOEM estimates that the sum of the average annual TAPS related effect, SOA corporate income taxes, and SOA property taxes (after transfer to the NSB) would be approximately \$3.5 million. The oil and gas property taxes collected would be from new onshore infrastructure (landfall infrastructure and pipelines) associated with the project. The total average annual revenue to the SOA from the Proposed Action would be approximately \$13.3 million which represents less than one percent of the \$7.6 billion in total SOA oil and gas revenues. The relatively small amount of annual SOA revenues associated with the Proposed Action would have little to no effect on the SOA economy, resulting in a negligible effect.

However, it is worth noting that the Proposed Action would generate approximately \$533 million in revenues to the SOA and \$1.1 billion to Federal government over the life of the Proposed Action. The beneficial revenue effects could help offset declining oil production in the state to some degree. A negligible impact finding does not diminish these potential contributions.

NSB Revenues

The NSB would receive approximately \$1.1 million in annual property tax revenues passed through from the SOA as a result of the Proposed Action, and approximately \$35.2 million total over the life of the project. Compared to the \$340 million in property tax revenues on the oil and gas infrastructure in the NSB in 2015, the incremental annual effect would be less than one percent. However, as noted above in Section 3.3.2.2, property tax payments by North Slope oil producers are the main source of revenue for the NSB (accounting for approximately 90% of the NSB operating budget in 2015), and these revenues directly support wages for NSB government jobs held by Borough residents.

In addition, under the SOA's Community Revenue Sharing Program, the NSB also receives revenues which would increase slightly as a result of the larger number of oil and gas workers in the NSB because of the Liberty project. These workers would be counted as permanent residents for purposes of calculating revenue sharing per capita payments to the NSB. These revenues would be provided through services and funding to NSB communities, such as education, public safety, and health and social services.

Although the incremental impact of annual NSB revenues associated with the Proposed Action would be less than one percent, these revenues directly support wages for NSB residents and indirectly support local services. The combination of these factors is likely to translate to moderate positive effects on the NSB economy.

Population

This section considers the relative impacts to the population base that could occur as a result of the direct jobs forecast in Tables 4.4.2-1 and 4.4.2-2 if workers relocate as a result of the employment. The estimates presented in Tables 4.4.2-1 and 4.4.2-2 are representative of where workers are likely to reside while employed on the project, not where the jobs will physically be located.

A portion of the other U.S. jobs would physically be located in the NSB but would be filled by long-distance commuters from other states. The percentage of workers in the Alaska oil and gas industry who are non-residents of the state rose from 30 percent in 2005 to 36 percent in 2015 (ADLWD, 2015f). However, non-resident workers would be housed in existing Liberty Development facilities away from local village communities in the area while they are working on the project. The physical separation of workers from established local communities makes it less likely that they would settle in communities of the NSB.

State of Alaska Population

Few workers are expected to permanently relocate to Alaska as a result of the Proposed Action. The estimated peak annual and long term average jobs associated with the Proposed Action are small relative to the population base. Small population increases could occur but they would likely be in larger communities that already support oil- and gas-related activities (e.g., Anchorage) and would have little or no impact. Relative to the 2015 SOA population (737,200), the maximum population increase as a result of the Proposed Action would be less than one percent. Thus, the Proposed Action is likely to have little or no impact on the population base of the SOA, resulting in a negligible effect.

NSB Population

Few workers are expected to permanently relocate to the NSB as a result of the Proposed Action. Workers would be housed in existing Liberty Development facilities away from local village communities in the area. The physical separation of workers from established local communities makes it less likely that they would settle in communities of the NSB. Thus, the Proposed Action is likely to have little or no impact on the population base of the NSB, resulting in a negligible effect.

Social Cost of Carbon (SCC)

BOEM is incorporating information from the 2017-2022 Programmatic EIS (BOEM, 2016a) by reference and summarizing relevant information here. BOEM has presented the social cost of carbon for the 2017-2022 Program in a separate technical report on greenhouse gas emissions (Wolvovsky and Anderson, 2016), and then summarized and referenced that broader analysis, as appropriate, in BOEM's Economic Analysis Methodology for the 2017–2022 OCS Oil and Gas Leasing Program (BOEM, 2016b). That document provides the context and assumptions used for BOEM's calculations and provides an appropriately broad scale for analysis for BOEM to incorporate the social benefits of reducing carbon dioxide emissions into its decision-making.

Using these previous models and assumptions, BOEM calculated the SCC for the Liberty DPP, shown below in Table 4.4.2-6. (Wolvovsky, 2016; Maisonet, Personal Communication, 05/10/2017). BOEM used the estimated recoverable oil and the anticipated production levels from Section 1.1 to calculate the SCC numbers below. For each emissions year, BOEM used four sets of SC-CO₂ values: three values based on the average SCC from three integrated assessment models, discounted at 2.5%, 3%, and 5%, as well as a fourth value corresponding to the 95th percentile of the frequency distribution of SCC estimates at the 3% discount rate. Discounting is the process used for determining the present monetary value of future social costs. These numbers were monetized and annualized, however, they do not constitute a full cost-benefit analysis.

The Economic Analysis Methodology also analyzes a No Action alternative which accounts for the CO_{2e} contributions associated with the lifecycle CO_{2e} emissions associated with replacement fuels (anticipated to be a mix of coal, oil, natural gas, and renewables), and also accounts for the estimated marginal reduction in energy demand. The market substitution concept acknowledges that if oil and gas were not produced from the Liberty prospect, other energy sources would be utilized to keep the supply of energy in line with demand. Additional detail on GHG emissions for the No Action and Proposed Action and action alternatives are provided in Section 4.2.4. The overall lifespan of the development and production activities, as well as the total amount of oil produced from the Liberty prospect would not vary significantly among action alternatives.

BOEM's overall economic analysis does not monetize most major benefits and revenue streams from its lease sales, but seeks to quantify beneficial impacts related to employment numbers and labor income. For this reason, the SCC is not a direct comparison with the benefits quantified above.

Table 4.4.2-6. Social Cost of Carbon (in billions of dollars) at Various Discount Rates.

Discount Rate	Proposed Action and Action Alternatives	No Action Alternative
5.0%	0.622	0.853
3.0%	2.548	3.513
2.5%	3.945	5.444
3.0% (95 th percentile)	7.69	10.610

Accidental Oil Spills

The NSB is a mixed cash-subsistence economy. This section discusses economic impacts from potential oil spills in terms of traditional measures of population, employment, income, and revenues. For analysis of potential impacts to subsistence-harvest patterns and sociocultural systems, please see Sections 4.4.3 and 4.4.1, respectively.

This discussion of employment, income, and revenues for oil-spill response is based on the most relevant historical experience of a spill in Alaskan waters, the Exxon Valdez Oil Spill (EVOS) of 1989. That spill was 240,000 bbl. It generated substantial employment of up to 10,000 workers doing cleanup work in relatively remote locations. Smaller numbers of cleanup workers returned in the warmer months of each year following 1989 until 1992. The EVOS also had adverse effects on jobs and income associated with commercial and recreational fishing. During the EVOS, numerous local residents quit their jobs to work on the cleanup, often at significantly higher wages. This generated additional adverse effects in the form of sudden and significant inflation in the local economy (Cohen, 1993). Similar adverse effects on the NSB as a result of a large spill would be mitigated due to the likelihood that cleanup activities, including administrative personnel and spill-cleanup workers, would likely be located in existing enclave-support facilities. This physical separation of workers from communities of permanent residents of the NSB would make it less likely that incoming non-resident cleanup workers would settle in the NSB, minimizing population impacts.

In the event of small or large oil spills, the number of workers employed for cleanup would depend on several factors. These include the procedures called for in the Oil-Spill Response Plan (OSRP), how well-prepared with equipment and training the entities responsible for cleanup are, how efficiently the cleanup is executed, and how well coordination of the cleanup is executed among numerous responsible entities.

Small spills

Small spills of crude or refined oil (i.e., <1,000 bbl) are accidental events that have occurred with general routine frequency and are assumed to occur from the Proposed Action during its lifetime. In general, small oil spills tend to be contained at the initial spill site. BOEM estimates that it would require <100 annual jobs to respond, clean up and contain the small spills that may occur over the life of the project and that no additional onshore infrastructure would be needed to support the cleanup efforts. Consequently, small oil spills would have little measurable impact on population, employment, income, and revenues and impacts to the U.S., SOA, and NSB economies would be considered negligible.

Large spill

Although an unlikely event, one large spill of crude or refined oil is assumed to occur during the development and production phase of the Proposed Action. A large oil spill between 1,000 and 5,100 barrels could generate several hundred direct and indirect jobs and thousands of dollars in personal income associated with oil-spill response and cleanup in the short term. As context, a spill size of 5,100 is approximately 2.1% of the EVOS spill size; taking 2.1% of the 10,000 workers who cleaned up the EVOS would translate to approximately 210 workers. A large spill is expected to have little adverse effects on employment and wages in other sectors of the SOA or NSB economies. The relatively small number of jobs and associated labor income associated with the cleanup efforts would

likely have little to no effect on the SOA economy. The effects on the NSB economy would depend on the extent to which Borough residents are employed in the cleanup efforts, but are likely to be negligible to minor due to the temporary nature of the jobs.

Potential positive revenue impacts would include property tax revenues accruing to NSB from any additional onshore infrastructure built to house the influx of workers and to support cleanup efforts. However, extra ships staged offshore would likely be the primary source of additional infrastructure used to support the response and cleanup efforts. Thus, a large spill is expected to have little to no impact on NSB revenues, resulting in a negligible effect on the NSB economy.

The associated SOA and NSB population effects are likely to be negligible due to the temporary nature of the jobs, physical separation of worker housing, and low likelihood of workers permanently relocating to the NSB or the rest of Alaska.

Conclusion

Table 4.4.2-7 provides summary information on the various economic measures used to support the overall impact conclusion of the Proposed Action on the SOA and NSB economies.

Table 4.4.2-7. Summary of Effects by Economic Measure.

Economic measure:	SOA Routine Activities	NSB Routine Activities	SOA Small Oil Spills	NSB Small Oil Spills	SOA Large Oil Spill	NSB Large Oil Spill
Employment / Wages	Negligible	Negligible to Minor	Negligible	Negligible	Negligible	Negligible to Minor
Revenue	Negligible	Moderate	Negligible	Negligible	Negligible	Negligible
Population	Negligible	Negligible	Negligible	Negligible	Negligible	Negligible

The Proposed Action is expected to have negligible beneficial effects on SOA employment, labor income, and revenues. The beneficial impacts on NSB employment and income are likely to range from negligible to minor, while the beneficial impacts on NSB revenues are expected to translate to moderate impacts on the NSB economy. The Proposed Action is likely to have little to no impact on the population base of the SOA or the NSB.

Overall, the Proposed Action is expected to have a negligible beneficial impact on the SOA economy and a negligible to moderate beneficial impact on the NSB economy.

As described in Chapter 3, global climate change could alter current conditions in the Proposed Action Area during the life of the Proposed Action. BOEM does not anticipate, in this relatively short timeframe, climate change would alter the impacts of the Proposed Action to the SOA and NSB economy as described in Chapter 4.

4.4.2.2. Effects of Alternative 2 on the Economy

Under Alternative 2, the economic benefits including jobs, labor income, and revenues at the NSB and SOA levels would not occur. Any beneficial or adverse impacts from employment-related population changes and oil spills would also not occur.

4.4.2.3. Effects of Alternative 3 on the Economy

Section 2.2 and the summary in Table 2.2.6-1 describe the differences in the project aspects among alternatives. Although there may be small differences in employment needed to construct and decommission the project's various supporting infrastructure (ice roads, gravel mine, LDPI, pipeline, and processing facilities) under the different alternatives, the peak annual and longer-term average employment effects are likely to be comparable to those of the Proposed Action. Thus the associated labor income and population effects are also expected to be similar to those of the Proposed Action.

Most of the revenue effects would also be similar to those of the Proposed Action, with the exception of the noted differences in property taxes collected on oil- and gas-related infrastructure.

Under Alternative 3, the proposed LDPI would be relocated (Section 2.2.4). Alternative 3A would relocate the proposed LDPI one mile to the east into deeper water, and Alternative 3B would relocate the proposed LDPI 1.5 miles to the southwest into slightly shallower waters managed by the SOA. Alternative 3B would presumably result in increased property tax revenues to the SOA as a result of moving the proposed LDPI into state-managed waters. BOEM's assumes that the SOA would not share property taxes collected on oil- and gas-related infrastructure in state waters with the NSB; however, BOEM considered the possibility of these additional revenues accruing to the NSB in developing the impact conclusion in case this assumption is incorrect.

Conclusions for Alternatives 3A and 3B

The effects of Alternative 3A and Alternative 3B on SOA and NSB employment, labor income, population, and revenues would be largely the same as those for the Proposed Action. While there may be increased property tax revenues to the SOA (and possibly the NSB) as a result of moving the proposed LDPI into state-managed waters, the incremental increase in annual revenues would be relatively small and thus would result in the same impact conclusions as the Proposed Action.

4.4.2.4. Effects of Alternative 4 on the Economy

Section 2.2 and the summary in Table 2.2.6-1 describe the differences in the project aspects among alternatives. Although there may be small differences in employment needed to construct and decommission the project's various supporting infrastructure (ice roads, gravel mine, LDPI, pipeline, and processing facilities) under the different alternatives, the peak annual and longer-term average employment effects are likely to be comparable to those of the Proposed Action. Thus the associated labor income and population effects are also expected to be similar to those of the Proposed Action. Most of the revenue effects would also be similar to those of the Proposed Action, with the exception of the noted differences in the property taxes collected on oil- and gas-related infrastructure.

Under Alternative 4, oil and gas processing would be relocated to one of two alternate facilities (Section 2.2.5). Alternative 4A would relocate oil and gas processing activities to an existing facility at Endicott located to the west of the Proposed Action Area. Alternative 4A would extend the useful life of the existing gas processing facility, and thus allow for continued property tax revenues over the life of the Proposed Action. Alternative 4B would relocate oil and gas processing to a new onshore facility that would need to be built near the Badami pipeline tie-in point. Both Alternatives 4A and 4B would increase property tax revenues for the SOA and the NSB.

Conclusions for Alternatives 4A and 4B

The effects of Alternative 4A and Alternative 4B on SOA and NSB employment, labor income, population, and revenues would be largely the same as those for the Proposed Action. While there would be increased property tax revenues to the SOA and the NSB as a result of relocating the oil and gas processing facilities, the incremental increase in annual revenues would be relatively small and thus would result in the same impact conclusions as the Proposed Action.

4.4.2.5. Effects of Alternative 5 on the Economy

Section 2.2 and the summary in Table 2.2.6-1 describe the differences in the project aspects among alternatives. Although there may be small differences in employment needed to construct and decommission the project's various supporting infrastructure (ice roads, gravel mine, LDPI, pipeline, and processing facilities) under the different alternatives, the peak annual and longer-term average employment effects are likely to be comparable to those of the Proposed Action. Thus the associated labor income and population effects are also expected to be similar to those of the Proposed Action.

Most of the revenue effects would also be similar to those of the Proposed Action, with the exception of the noted differences in property taxes collected on oil- and gas-related infrastructure.

Alternative 5 would relocate the proposed gravel mine (Section 2.2.6). There are three alternate mine sites, including two new sites east of the Kadleroshilik River (Alternatives 5A and 5B) and the existing Duck Island mine site in the Sagavanirktok River Delta (Alternative 5C). Alternative 5 would not result in additional property tax revenues over the Proposed Action.

Conclusion for Alternatives 5A, 5B, and 5C

Impacts from Alternatives 5A, 5B, and 5C on the SOA and NSB economy would essentially be the same as the impacts described for the Proposed Action.

4.4.3. Subsistence Activities and Harvest Patterns

4.4.3.1. The Proposed Action

This section reports the impacts analysis for the Proposed Action on subsistence activities and harvest patterns for Nuiqsut, Kaktovik, and Utqiagvik. As described in Chapter 3, subsistence ways of life and harvest practices are fundamental to Alaska Native communities in the North Slope Borough (NSB) and provide important food resources and the foundation of community values and cultural identities. For impacts to subsistence activities and harvest patterns, BOEM considered the fundamental importance of subsistence to Iñupiaq cultural, individual and community health, and well-being. Due to these unique characteristics of subsistence practices, impacts to subsistence activities and harvest patterns are considered severe and thus major if they would disrupt subsistence activities, make subsistence resources unavailable or undesirable for use, or only available in greatly reduced numbers for a substantial portion of a subsistence season or more.

Nuiqsut is approximately 80 miles (129 km) west of the proposed LDPI, and Kaktovik is approximately 94 miles (151 km) east of the proposed LDPI. Utqiagvik is located approximately 220 miles (354 km) west of the proposed LDPI. The Proposed Action Area overlaps with lands and waters traditionally and contemporarily used for subsistence harvests by residents of Nuiqsut and Kaktovik (Figure 3.4.3-1; Galginaitis, 2014a, 2014b; 2016; NSB, 2014; Pedersen, 1979, 1990; SRB&A, 2010). The Proposed Action Area is shown in Figure 2.2.2-1. Figure 3.1.1-1 shows a wider area surrounding the Proposed Action Area. Both are important for subsistence activities practiced by residents of Nuiqsut and, to a lesser extent, Kaktovik.

The primary subsistence activity that could be affected by the Proposed Action is bowhead whaling conducted by crews from Nuiqsut near Cross Island (Galginaitis, 2014b; Hilcorp, 2015, Appendix A). Cross Island is located approximately 18 miles northwest of the proposed LDPI. Most other contemporary subsistence harvests in the Proposed Action Area are incidental to coastal travel for other purposes and opportunistic. The Proposed Action Area has historically been used by Iñupiat harvesters from Nuiqsut and Kaktovik (Pedersen, 1979). The Proposed Action Area could become a more regularly used and important harvest area at times during the 25-year life of the Proposed Action. Local people could foreseeably travel to the Proposed Action Area to intentionally look for seals, caribou, fish, or migratory waterfowl if and when these become unavailable at more highly preferred harvest areas closer to Nuiqsut and Kaktovik.

NPDES-permitted discharges are anticipated to have no impact on subsistence activities or harvest patterns under the Proposed Action and alternatives.

As described in Chapter 3, global climate change could alter current conditions in the Proposed Action Area during the 25-year life of the Proposed Action. BOEM does not anticipate, in this relatively short timeframe, that climate change would alter the impacts of the Proposed Action to subsistence harvest patterns as described in Chapter 4.

A primary source of information for this section is Galginaitis (2014b) adopted from the 2015 Liberty EIA (Hilcorp, 2015, Appendix A). Further discussions are found in OCS EIS/EA MMS 2002-019, Final Environmental Impact Statement for Liberty Development and Production Plan (USDOJ, MMS, 2002); Final Environmental Impact Statement for Beaufort Sea Oil and Gas Development/Northstar Project (USACE, 1999); OCS Study MMS 2009-003 (SRB&A, 2010); OCS Study BOEM 2013-212 (SRB&A, 2013); and OCS Study BOEM 2013-218 (Galginaitis, 2014a, 2016).

In accordance with lease stipulations pertaining to the protection of subsistence activities, HAK has consulted with potentially affected subsistence communities, the NSB, and the AWEC during development of the Proposed Action to discuss potential conflicts between operations and subsistence activities and harvest patterns, and to identify measures to prevent unreasonable conflicts. Similar coordination is required in order for HAK to obtain an incidental take authorization under the MMPA. A list of measures that HAK would implement in order to reduce potential impacts on subsistence is provided in Appendix C (C-7). Implementation of these measures (e.g., establishment of preferred vessel routes and minimum flight altitudes) is assumed in the following effects analysis. It is acknowledged that HAK has committed to taking part in the Conflict Avoidance Agreement (CAA) with the AEWC and to abide by the CAA each year that marine operations are conducted in support of the Proposed Action. Past CAAs have included various measures (e.g., minimum flight altitudes, vessel routing, other seasonal restrictions) designed to manage interactions between subsistence activities and offshore oil and gas activities. It is possible that measures incorporated into future CAAs would serve to reduce potential impacts from the Proposed Action. However, since the CAA is renegotiated every year, it is not possible to know what specific provisions would be contained in each CAA going forward. This section therefore analyzes potential effects from the Proposed Action as it is described in the DPP, and does not assume the implementation of any additional mitigation measures that may or may not be included in future CAAs.

Overlap of the Proposed Action and Subsistence Activities

BOEM examined temporal and spatial overlap between specific subsistence hunting and fishing activities and the Proposed Action (Table 4.4.3-1). Temporal overlap (i.e., time) indicates that the timing of proposed actions overlaps with peak subsistence seasons; spatial overlap (i.e., area) indicates that a subsistence area(s) currently overlaps with the Proposed Action Area or has overlapped with the Proposed Action Area in the past.

The Proposed Action is comprised of several sub-activities scheduled to occur at set times and durations (Figure 2.1.1-1). BOEM found some temporal overlap between specific components of the Proposed Action and specific subsistence activities for Nuiqsut, Kaktovik, and Utqiagvik (Table 4.3.1-2). BOEM also found potential spatial overlap between specific components of the Proposed Action and specific subsistence activities for Nuiqsut and Kaktovik (Table 4.4.3-2).

Table 4.4.3-1. Primary Subsistence Hunting and Fishing Activities for Nuiqsut, Kaktovik, and Utqiagvik.

Community	Bowhead Whales	Seals	Caribou	Fish	Waterfowl	Overlap with Proposed Action ¹
Nuiqsut	Late August-September; launched from Cross Island 100 miles east of community; all strikes in an area along the coast extending from Northstar unit in the west to Bullen Point in the east, 30-50 miles off the coast	June-September along coast and up to 40 miles offshore between Harrison Bay and Flaxman Island; most hunts near Thetis Island	June-September on the coast and barrier islands by boat between Atigaru Point and Oliktok Point and Colville River Delta; October-February with snowmachines	Arctic cisco: September-December in Colville River Delta; Arctic char: August-September in the Colville River; Broad whitefish: June-August and October in Colville River Delta and Fish Creek	Geese: April-June in Fish Creek and Colville River Delta; Eiders: May-September up to 10 miles offshore of Colville River Delta and east to Thetis and Cross Islands	Some temporal overlap with Proposed Action; could be some spatial overlap between summer construction activities at proposed LDPI and whale scouting, seal hunting, and eider hunting
Kaktovik	Late August-September up to 50 miles off the coast in an area between Camden Bay in the west and Nuvagapak Lagoon in the east	June-September along the coast and up to 30 miles offshore; between Canning River and Pokok Lagoon	June-September on the coast and barrier islands by boat between Bullen Point (sometimes to Foggy Island) and Canada; November-April with snowmachines	Arctic cisco: July-August in coastal areas; Arctic char: July-August in inland rivers and coastal areas; Broad whitefish: July-August in coastal areas and river mouths	Geese: May-September in coastal areas and inland rivers; Eiders: May-September in coastal areas and inland rivers	Some temporal overlap with Proposed Action; could be spatial overlap between winter construction activities and caribou hunting and summer construction at proposed LDPI and caribou, seal, and waterfowl hunting
Utqiagvik	Two hunts: April-May from the ice west of Point Barrow and close to shore and September-October, 20 or more miles off the coast between Skull Cliff in the west and Smith Bay in the east	June-August, some seals taken year round; along coast and over 20 miles offshore between Skull Cliff and Point Barrow	July-September by boat along the coast and inland rivers between Icy Cape and Prudhoe bay	Arctic cisco: July-November near town or by trip to Nuiqsut; Arctic char: July-August in Kugrua River; Broad whitefish: July-October south of town in rivers feeding Dease Inlet	Geese: May-June south of town in rivers feeding Dease Inlet and offshore; Eiders: May-August offshore north and west of town	Some temporal overlap with summer island construction activities and gravel mine reclamation; no spatial overlap with Proposed Action

Note: ¹ Temporal means the timing of proposed actions overlaps with subsistence seasons; spatial means the Proposed Action Area overlaps with current or historic subsistence hunting and fishing areas.

Table 4.4.3-2. Proposed Action Temporal and Spatial Overlap with Primary Subsistence Activities.

Proposed Action	Timing	Duration	Location ¹	Overlap with subsistence ²
Ice road construction and maintenance	December-April	20 months; 4 construction seasons; years 1-5	2 onshore; 3 offshore ³	Temporal with winter caribou hunting (N and K); could be spatial with winter caribou hunting (K)
Gravel mine site development, mining, and hauling	January-April	4 months; year 1	0.5 mile south of Foggy Island Bay; west of Kadleroshilik River; between mine and LDPI	Temporal with winter caribou hunting (N and K); could be spatial with winter caribou hunting (K)
Gravel mine reclamation	May-September	5 months; year 1	0.5 mile south of Foggy Island Bay; west of Kadleroshilik River	Temporal with summer caribou hunting, fishing, and waterfowl hunting (N, K, Utqiagvik); could be spatial with summer caribou hunting and waterfowl hunting (K)
LDPI construction	February-April	3 months; year 2	LDPI	Temporal with winter caribou hunting (N and K); could be spatial with winter caribou hunting (K)

Proposed Action	Timing	Duration	Location ¹	Overlap with subsistence ²
LDPI slope protection (grading, sheet pile driving, and armament installation)	May-August	4 months; year 2	LDPI	Could be temporal with Cross Island bowhead scouting (N); could be spatial with scouting for whales (N); temporal with summer caribou hunting and fishing (N, K, and Utqiagvik); temporal with seal hunting (N, K, and Utqiagvik); could be spatial with seal hunting (N and K); temporal with waterfowl hunting (N, K, and Utqiagvik); could be spatial with eider hunting (N); could be spatial with eider and geese hunting (K)
Onshore and offshore pipeline construction and installation	January-May	5 months; year 3	Between Badami pipeline tie-in and LDPI	Temporal with winter caribou hunting (N and K); could be spatial with winter caribou hunting (K)
Facilities construction	October-April	19 months; years 2-4	LDPI	Temporal with winter caribou hunting and fishing (N and K)
Hovercraft hangar, boat dock, fuel tank construction	February-April	3 months; year 2	SDI	Temporal with winter caribou hunting (N and K)
Drilling	Year round	27 months; years 3-5	LDPI	Temporal with all subsistence activities
Production	Year round	years 4-20	LDPI	Temporal with all subsistence activities
Decommissioning	October-May	18 months over 2 winter seasons	LDPI and onshore pipeline	Temporal with all winter subsistence activities; could be spatial with winter caribou hunting (K) for onshore pipeline

Notes: ¹ LDPI = Liberty Drilling and Production Island site; SDI = Satellite Drilling Island at Endicott;

² N = Nuiqsut, K = Kaktovik

³ Two onshore ice roads and three offshore ice roads.

BOEM analyzed potential effects to specific subsistence activities in cases where those activities were found to have potential for both temporal and spatial overlap with the Proposed Action and its component activities. Subsistence activities that may overlap in both time and space with the Proposed Action include 1) bowhead whaling for Nuiqsut, 2) seal hunting for Nuiqsut and Kaktovik, 3) winter and summer caribou hunting for Kaktovik, and 4) waterfowl hunting for Nuiqsut (i.e., eiders) and Kaktovik (i.e., eiders and geese).

BOEM found no spatial overlap between the Proposed Action and areas used by residents of Utqiagvik for subsistence harvests. Utqiagvik is included in this analysis because there is concern about potential contamination of and disruptions to subsistence species that travel or migrate through or near the Proposed Action Area, including bowhead whales harvested in fall near Utqiagvik and Kaktovik and Arctic cisco harvested in the Colville River Delta. Moreover, crude and refined oil spills could potentially occur during the 25-year life of operations and could adversely affect subsistence activities and harvest patterns outside the immediate Proposed Action Area.

Effects on Subsistence Harvests

Bowhead Whaling Practices

The Proposed Action Area is near the fall migratory route of bowhead whales (Clarke et al., 2015a; Quakenbush et al., 2010). Bowhead whales are a highly important animal and subsistence resource for residents of Nuiqsut, Kaktovik, and Utqiagvik (Section 3.3.3; Galginaitis, 2014a; SRB&A, 2010; USDO, MMS, 2002).

The Nuiqsut subsistence bowhead hunt is launched from a base camp about 100 miles away from the village on Cross Island. The Proposed Action Area is located 18 statute miles to the southeast of Cross Island (Galginaitis, 2014b). BOEM focused this analysis on potential effects of the Proposed Action on Nuiqsut's bowhead whale hunt because it overlaps with the Proposed Action in time and could overlap with the Proposed Action in space, particularly if construction activities occur at the proposed LDPI during summer and early fall (i.e., August-September). If bowhead whales were to increase their use of areas coastward closer to the proposed LDPI during the 25-year life of

operations, Nuiqsut's whaling practices could potentially overlap more closely in space with the Proposed Action.

Whaling conducted by crews from Kaktovik and Utqiagvik does not spatially overlap with the Proposed Action Area. With the exception of a large oil spill, effects on bowhead whaling practices for Kaktovik and Utqiagvik are expected to be negligible during the development and production life of the Proposed Action. Communities in the NSB that have sharing relationships with Nuiqsut could experience adverse sociocultural and health effects if the overall success rate of the Cross Island bowhead whale hunt was adversely affected to the degree that Nuiqsut was not able to share bowhead whale with them for one or more seasons.

Historically, the Nuiqsut bowhead hunt occurred around the start of September through mid-October. Whaling seasons in 2001 through 2013 have begun in late August and lasted through mid-September. In 2015, the Cross Island whaling season extended over 19 days from August 25 through September 12 (Galginaitis, 2016). Nuiqsut crews go whaling immediately north of the Proposed Action Area, and in some years have scouted for whales directly in the Proposed Action Area (Galginaitis, 2014a, 2014b). All of Nuiqsut's documented whale strikes have been within an area extending from about the Northstar unit in the west to Bullen Point in the east in the vicinity of Cross Island and 30-50 miles off the coast (Figure 3.3.3-4; Galginaitis, 2009, 2014a, 2014b, 2016; SRB&A, 2010).

Construction and support activities conducted during the open-water season; regular drilling, production, and processing operations; and oil spills could contribute to potential adverse effects on whaling conducted by crews from Nuiqsut (Galginaitis, 2014b). Effects on Cross Island whaling practices would most likely only occur in August through September during the open-water season. Thus winter activities other than oil spills such as gravel mining, proposed LDPI construction, and ice road construction and maintenance are expected to have negligible impacts on subsistence whaling.

The Proposed Action could cause adverse effects to subsistence whaling activities launched from Cross Island, including 1) deflection of movements for some whales occurring inside the barrier islands farther offshore, 2) interference from support vessels, 3) avoidance of the Proposed Action Area by Nuiqsut whalers due to the presence of the proposed LDPI and production facilities and perceptions of tainted or contaminated resources, 4) whaling conflicts with summer construction activities such as sheet pile driving (i.e., LDPI slope protection), and 5) oil spills (Galginaitis, 2014b).

Deflection of Bowhead Whales

Iñupiat people on the North Slope are concerned about the potential of offshore oil and gas activities to interfere with subsistence whaling practices (Galginaitis, 2014a, 2014b, 2016; ICAS, 2012; NOAA, 2013; SRB&A, 2009, 2013). Noise in the marine environment is believed to be associated with lower whaling success (Long, 1996). Local concerns include deflection of migrating whales due to noise from seismic exploration, construction of off-shore structures, drilling, pipeline monitoring, support vessel and aircraft traffic, and other industrial activities (Burns and Bennett, 1987; EDAW AECOM, 2008; Huntington, 2013; Lefevre, 2013; NRC, 2003, p. 102; NOAA, 2013, p. 4-199; Nukapigak, 2011; SRB&A, 2009; USACE, 1999). Other local concerns are related to potential discharge of wastes, changes in ocean currents, and sedimentation due to artificial island construction. In its comments regarding BOEM's 2012-2017 OCS oil and gas program, the Iñupiat Community of the Arctic Slope (ICAS) (2012) wrote:

“We are also gravely concerned about a host of other impacts associated with offshore drilling. In the past, our whaling captains have experienced firsthand how underwater noises associated with drilling ... have interfered with the bowhead whale hunt at Cross Island. When whales are deflected from their normal migration route, our whaling captains are forced to travel great distances in dangerous conditions to obtain the food

that feeds our people. Our traditional knowledge tells us that bowhead whales are very sensitive to underwater noise ...”

Cross Island whalers report that areas near barrier islands, both seaward and coastward, can be important for migrating whales (Huntington, 2013). The area south of Narwhal Island is important for the migration of smaller whales; the whalers have observed that smaller whales avoid the deeper water north of Cross Island (Galginaitis, 2014b). Nuiqsut whalers, as a group, prefer to target smaller rather than larger whales when they are available, but some whaling captains have a reputation for taking larger whales (Galginaitis, 2014c). Subsistence whaling activities and harvest patterns could be adversely affected by noise and/or perceived disturbances that whalers associate with noise in the marine environment, especially scouting inside the barrier islands.

Nuiqsut whalers believe noise and other disturbances from the Proposed Action over the 25-year life of the operation would deflect some whales seaward, which could increase the distance whalers need to travel to find and strike whales. Anticipation of greater travel distances on the part of the whalers could cause long lasting and widespread stress. Increased travel results in increased fuel expenses and increased risk to human safety and greater potential for meat spoilage (USACE, 1999). Nuiqsut whalers do not prefer to look for whales greater than 20 miles from Cross Island because striking whales farther than that away from camp can cause harvested whales to spoil during long tows back to camp. Based on their observations, Nuiqsut whalers expect that deflected whales would be disturbed, harried, exhibit more wary or skittish behavior, and thus become more difficult to approach for a strike (Galginaitis, 2014b; Huntington, 2013). Cross Island whalers did not observe or report skittishness in bowheads during the 2015 season (Galginaitis, 2016).

Nuiqsut whalers report that the presence of the proposed LDPI may change sea current patterns (Galginaitis, 2014b). Since migrating bowhead whales commonly follow currents, the presence of the proposed LDPI is a concern for whalers and could cause long lasting and widespread stress for whaling crews and residents of Nuiqsut. This is because the proposed LDPI would most likely be viewed as a physical source of disturbance to ocean currents, which also is believed to alter movement patterns of bowhead whales.

Overall, worry and stress on the part of the whalers due to the possibility of having to scout farther out to sea for skittish whales due to deflection of whale movements are expected to be long lasting and widespread and thus moderate. These impacts would most likely affect all whaling crews from Nuiqsut during the 25-year life of the Proposed Action. This finding is specific to the behaviors of whaling crews engaged in subsistence harvest of bowhead whales; it is independent of the biological finding of negligible effects to bowhead whales from noise produced by the Proposed Action (Section 4.3.4.1.1).

Support Vessel Traffic

Subsistence whalers using Cross Island as a base camp have a great sensitivity to vessel and aircraft traffic and associated noises as disruptive factors to their hunt because of recent personal experience (Galginaitis, 2014b; NOAA, 2013, p. 4-199; NOAA, 2016, p. 4-212 and 4-213). The Cross Island whaling season is relatively short, taking place within a window of about four weeks when the whales are present, temperatures are cool, and weather and other conditions are most likely to be favorable for scouting for whales. The Cross Island whalers prefer a season length of two to three weeks (Galginaitis, 2014a). The number of scouting days available to look for whales is limited, especially if there are some days when weather or ice conditions prevent the whalers from looking for whales, which has been the case for most recent seasons since 2001 (Galginaitis, 2014a, 2016). Whalers hold strongly negative attitudes toward any unexpected or unpredictable factors that may interfere with the subsistence hunt on days suitable for scouting. Negative attitudes toward disturbances can affect scouting behaviours independent of negligible biological effects to the bowhead whale population.

Scouting is a term used by whalers that means being on the water looking for whales to strike and may be used interchangeably with whale hunting or whaling in this section.

Three or four whales generally provide enough for the needs of Nuiqsut and those communities with which they share. Their target is about 120 feet of whale, roughly four whales of 30 feet each; Nuiqsut whaling captains typically say that a 30 to 35 foot whale (or two 25-footers) meets the requirements for a Nulukataq celebration in June (Galginaitis, 2016, p. 24). For the period 2001 to 2013, Cross Island whalers were able to meet their needs for bowhead harvest in all but the 2005 and 2009 seasons. Nuiqsut only harvested one whale in 2005 and two whales in 2009 (Galginaitis, 2016, p.11). While perceived interference from commercial vessel traffic (unrelated to the petroleum industry) was only one factor in their lack of success, at the time it was the most prominent factor from the whalers' perspective regarding their lower success (Galginaitis, 2014b). Adverse ice conditions in 2005, poor visibility and weather conditions for whaling in 2005 and 2009, and mechanical problems in both years were other factors leading to lower than normal success (Galginaitis 2014a).

In the 2015 season, the Cross Island whalers did not use their full quota. Galginaitis (2016) reported that the whalers did not attribute their inability to fill their quota to interference from commercial vessel traffic or the skittishness of the whales. They did report that whales were swimming faster than expected. The whalers explained their inability to fill their quota in 2015 as a factor of poor weather conditions; difficult hunting due to ice in the water combined with fog on several days and rough seas in open water; and relatively large travel distances from Cross Island to located whales.

Perceived interference from industrial and commercial vessel traffic such as barges in their whaling area is currently one of their primary concerns regarding the success of whaling from Cross Island (Galginaitis, 2016). Whaling crews are adversely impacted from a psychological standpoint when they encounter unexpected boats or aircraft in the Cross Island area while on the water looking for whales. During the open-water season, Hilcorp proposes to use barges, hovercraft, and tug boats to transport equipment, personnel, and supplies to the proposed LDPI; barge traffic related to the Proposed Action is expected to be most frequent during Execute Year 2 to support proposed LDPI construction (Hilcorp, 2015, pp. 35, 129). Physical interference with whaling operations from industrial vessels could occur. The opportunity to strike a whale may be relatively infrequent during a given season, and anything that may interfere with a possible strike opportunity should, from the whalers' perspective, be avoided at all costs (Galginaitis, 2014b). If lower than normal success in whaling occurs during a season in which vessels are encountered, the whalers would most likely attribute the cause of poor success to the vessel encounter. Disturbance from vessel traffic to whaling could be long lasting and widespread and thus moderate. BOEM anticipates no impacts to whaling practices or any other subsistence activities and harvest patterns from discharges from support vessels under the Proposed Action or alternatives.

Whaler Avoidance

Whalers and other subsistence hunters often report that they avoid areas of industrial development while they are hunting (Galginaitis, 2014b, 2016). If Liberty is developed, the Cross Island whalers may avoid the Proposed Action Area due to the presence of the proposed LDPI. Avoidance behavior on the part of Nuiqsut whalers has been documented for the Northstar development, but it is unclear to what extent their avoidance of Northstar has affected whaling success for hunts now launched from Cross Island. Nuiqsut whalers landed a whale in the Northstar area in 1997 before it was developed. During the fall migration, bowhead whales approach Cross Island from the east, and Northstar is located to the west of Cross Island. Nuiqsut whalers generally head northeast or east and less frequently north and northwest from Cross Island when looking for whales. They normally encounter bowhead whales before the whales pass the Northstar unit. On those few occasions when whaling

boats do approach Northstar, they turn away from it at a distance of two to three miles (Galginaitis, 2014b).

Cross Island whalers currently have a strong preference to scout for whales northeast of Cross Island (Galginaitis, 2014b). When adverse ice conditions in 2005 and 2006 prevented them from looking for whales to the northeast of Cross Island, the whalers still avoided approaching closer than two to three miles from Northstar. Whalers normally do not approach closer than about six miles from Northstar when scouting. The whalers have said they moved their whaling operations farther east to Cross Island to avoid disturbances from exploration work at Northstar and other oil and gas exploration and development activities occurring west of Cross Island (Galginaitis, 2014b). Since development of Northstar, Nuiqsut whalers report that they rarely scout for whales in that area (Galginaitis, 2016, p. 28). It is probable that Nuiqsut whalers have largely been displaced from whaling in the Northstar area due to the presence of industrial development.

Cross Island whalers could avoid approaching the proposed LDPI as they now avoid the Northstar development. In all whaling seasons documented since 2001, avoiding the Proposed Action Area probably would have had a negligible adverse effect on the success of those hunts (Galginaitis, 2014b). The Proposed Action Area was only part of the whale search area during 2005 and 2006, and no whales were struck or landed near the Proposed Action Area. Whales were seen and heard in or near the Proposed Action Area during those two seasons but could not be approached close enough to make a strike. In 2005 and 2006, access to open water outside the barrier islands was restricted by ice and weather. In 2005, this was the case for the entire season except one day and for the first half of the 2006 season (Galginaitis, 2016, p. 11). In 2005, Nuiqsut only used one strike and landed one whale. In 2006, they filled the full quota of four whales; all four whales were landed seaward of the barrier islands once conditions in open water improved.

Nuiqsut whalers could stop scouting for whales in the Proposed Action Area. However, in seasons with adverse weather or ice conditions that prevent scouting northeast and east of Cross Island, the whalers may be required to look for whales coastward in or near the Proposed Action Area. The proposed LDPI is about 4.0 miles south of Narwhal Island. Cross Island whalers rarely scout for whales south of Narwhal Island. However, they have travelled through the Proposed Action Area while scouting for whales in the past, and in both 2005 and 2006 whaling took place south of Narwhal Island and north of the proposed LDPI on several days and represented a substantial portion of the whaling effort for those seasons. No whales were struck in this area, but several whale sightings were reported. If Cross Island whalers were displaced from scouting in the Proposed Action Area (i.e., near the proposed LDPI and between it and Narwhal Island) due to avoidance or other reasons related to the presence of the proposed LDPI, impacts to subsistence whaling for the community of Nuiqsut could be severe and thus major. These impacts would most likely only occur during whaling seasons in which whalers needed to scout for whales in the Proposed Action Area. For example, during adverse ice and weather conditions, the Proposed Action Area may become critically important to Cross Island whalers for scouting (Galginaitis, 2014c, 2016). To adapt to variable conditions and be able to locate and access whales, the whaling crews from Nuiqsut have a vital need for an expanded search area beyond where whales are usually expected to be found (Galginaitis, 2016, p. 24). This expanded search area would most likely include the Proposed Action Area for certain whaling seasons during the 25-year life of the Proposed Action.

The relationship between whaler avoidance of developed areas and interference from vessel traffic can be complicated by ice and weather conditions. The adverse ice and weather conditions that restricted the whalers' boating activities also affected commercial vessel traffic. In both 2005 and 2006, the whalers reported interference to their hunts by vessels transiting the area (Galginaitis, 2014b). Whaling and non-whaling vessels can become crowded inside the barrier islands during times of adverse ice and weather conditions. In years with conditions that prevent access of the whalers and other vessels to open water beyond the barrier islands, the Nuiqsut whalers could be limited to

scouting coastward of the barrier islands closer to the proposed LDPI and in the Proposed Action Area. At times during the 25-year life of the Proposed Action, the area inside the barrier islands may be the only area where whales are available to Nuiqsut whalers. If they were deterred from using it by the presence of the proposed LDPI and non-whaling vessels, their opportunities to strike whales could be severely reduced for one or more seasons depending on ice and weather conditions, resulting in major impacts to subsistence whaling for Nuiqsut. Whalers would be stressed and frustrated due to a perceived decrease in the quality of the hunt because of closer proximity to the Proposed Action. The avoidance effect would be limited to the Nuiqsut bowhead hunt and is not expected to directly affect whaling for Kaktovik and Utqiagvik.

Whalers may also choose to avoid the Proposed Action Area due to the perception that bowhead whales harvested there may be contaminated or tainted in some way because of oil spills, waste discharges, or other observed reasons related to the Proposed Action (Galginaitis, 2014b). Subsistence harvesters are highly sensitive to animals that exhibit lesions or other imperfections, and avoid taking animals they think may be tainted or sick (Galginaitis, 2014b; USDOJ, MMS, 2002). For several years after the *Exxon Valdez* oil spill, subsistence harvesters reduced their harvest of subsistence resources, and they frequently testified about avoiding tainted resources at public hearings (Fall, 1991; Fall and Field, 1996; NOAA, 2013). Negative perceptions about tainting of marine resources tend to linger in the minds of subsistence harvesters and could last for the lifetime of the Proposed Action, resulting in long lasting and widespread levels of stress and uncertainty over food safety throughout the communities of Nuiqsut and Kaktovik as was seen in communities affected by the *Exxon Valdez* and *Selendang Ayu* spills (Gill et al., 2011; Impact Assessment, Inc., 2011). Due to perceived tainting of whales, whalers might avoid the Proposed Action Area. Whaler avoidance could reduce or eliminate scouting for one or more seasons during the life of the Proposed Action. If this were the case, impacts to subsistence whaling for Nuiqsut would be severe and thus major.

LDPI Slope Protection

The Cross Island whalers would most likely prefer to avoid the immediate Proposed Action Area during construction and operations. The whalers would also prefer no construction activities and related vessel and aircraft traffic occur during the whaling season. LDPI slope protection work is proposed as part of construction of the proposed LDPI. This includes cutting a moat in the sea ice around the proposed LDPI, grading the LDPI with a crane and drag line, installing sheet piling, and installing concrete armament around the perimeter of the LDPI (Hilcorp, 2015). The slope protection activities are scheduled for four months during Execute Year 2 beginning in May and extending through August (Table 4.1.1-1; Hilcorp, 2015, p.16). Whale scouting by Nuiqsut crews now occurs in late August and early September and would be most at risk from impacts caused by slope protection work in summer, especially sheet pile driving.

Actual and perceived noise and disturbances from pile driving are expected to adversely affect whaling crews and whaling practices to a greater extent than whales. The assumed functional hearing range of bowhead whales includes the frequencies and decibel levels of sounds produced by pile-driving (Figure 4.3.4-2, Table 4.3.4-5). It is possible that a few bowhead whales leaving early on their westward fall migration could be impacted by noise from pile driving; the fall migration occurs closer to shore than does the spring migration, especially in years of low sea-ice (Section 3.2.4.1). Bowhead whales generally do not migrate inside of the barrier islands; however, individuals have been occasionally observed shoreward of the islands and at lagoon entrances (Section 3.2.4.1), and whalers sometimes scout for whales inside the barrier islands. Sound from proposed LDPI summer construction activities would be unlikely to affect most whales in lagoon entrances or inside the barrier islands due to shallow water. However, noise from sheet pile driving would interfere with whaling activities inside the barrier islands because it would disturb the whalers and cause them to worry about deflection of whales.

The whaling season for Nuiqsut would most likely start mid to late August. Noises and disturbances from slope protection work and support vessel traffic and helicopter overflights could cause severe and thus major impacts to subsistence whaling in the Cross Island area, especially if slope protection work at the proposed LDPI extends into August. The whalers predict potential effects could be deflection of bowhead whales further offshore because of noise and disturbance from summer construction activities and vessel traffic at the proposed LDPI, especially for whales occurring inside the barrier islands. See Section 4.3.4.1.1 for a discussion of potential biological impacts to bowhead whales. Subsistence whalers could completely avoid the Proposed Action Area due to summer construction activities, thereby potentially reducing whaling opportunities during construction years. See section above on whaler avoidance for more information about conditions that can limit spatial opportunities for whale scouting.

Oil spills and spill response

Residents of Nuiqsut, Kaktovik, and Utqiagvik have expressed substantial concerns over oil spills in the Beaufort Sea, especially effects to subsistence resources and industry's inability to clean up spilled oil in ice covered offshore waters (Goodyear and Clusen, 2012; SRB&A, 2009; USDO, MMS, 2002, p. III-72).

The size of an oil spill is a key variable in determining potential impacts. BOEM uses three categories of spills, including small, large, and VLOS. Small spills of crude or refined oil (i.e., <1,000 bbl) are accidental events that have occurred with general routine frequency and are assumed to occur from the Proposed Action during its lifetime. Although an unlikely event, one large spill of crude or refined oil (i.e., ≥1,000 bbl) is assumed to occur during the development and production phase of the Proposed Action. The potential effects of small and large oil spills on subsistence whaling are examined in this section. Potential effects of a VLOS on subsistence harvest patterns are examined in Section 4.7.9.2.

BOEM assumes about 70 small spills could occur during the lifetime of the Proposed Action, at any time of the year (an average of 2-3 small spills per year). Bowhead whales have been reported in the Proposed Action Area by Cross Island whalers in August and September (Galginaitis, 2007, 2008). Small spills are unlikely to affect individual bowhead whales, because small spills cover a small area and are less likely to persist in the environment (NOAA, 2016, p. 4-128; USDO, MMS, 2002). Small spills would most likely not reach the main bowhead whale migration route due to rapid dispersal and evaporation within hours to a few days. BOEM expects the number of bowhead whales potentially affected by small spills as a result of the Proposed Action to be negligible. If contact between oil and whales is made, the ensuing effects would most likely be nonlethal, although mortalities among individual whales would be possible depending upon the spill size, severity, weathering processes, and the duration of exposure. However, because of the low number of whales in the area where small spills may occur and dissipate it is unlikely mortality would occur (Section 4.3.4.1).

Small spills occurring in the open-water season during August through September would have the greatest potential to affect migrating bowhead whales and subsistence whaling for Nuiqsut and Kaktovik. If small spills contacted the shoreline of Cross Island during the whaling season, impacts to subsistence whaling could be severe and thus major because whalers would not be able or willing to haul harvested whales onto oiled beaches for processing for one or more seasons. However, a small spill in the Proposed Action Area would most likely not reach Cross Island or Kaktovik beaches due to relatively fast dispersion and evaporation.

If small spills occurred during the whaling season in the Proposed Action Area, whalers from Nuiqsut would most likely experience negative perceptions of tainting of whales. The effects to whalers and other residents of Nuiqsut from tainting or beliefs of contamination could be longer lasting than for effects of contact with small spills to individual whales. The whalers would be concerned that whales traveling through or harvested near the Proposed Action Area could be contaminated as a food

source. Stressful psychological effects caused by the perception of contamination and possible avoidance of bowhead whales due to small spills in the Proposed Action Area could be long lasting and widespread and thus moderate.

Impacts from a large spill of crude or refined oil are expected to be more substantial than potential effects of small spills. A large spill may originate at the proposed LDPI, offshore pipeline, or onshore pipeline (i.e., launch points). In Appendix A, Section A.2, BOEM presents the percent chance (i.e., probability) that a large oil spill starting at the proposed LDPI or pipeline launch points would contact subsistence use areas and other important natural resources. These probabilities are calculated on both an annual and seasonal basis. Annually, January through December, the Cross Island whaling area currently used by whalers from Nuiqsut has a 10% chance of being contacted by a large oil spill starting from the proposed LDPI and a 5% chance of being contacted by a large oil spill starting from the pipeline, 10 to 30 days after a large spill occurs. In the summer season, July 1 through September 30, the Cross Island whaling area has a 25% chance of being contacted by a large oil spill starting from the proposed LDPI and a 13% chance of being contacted by a large oil spill from the pipeline, 10 days after the spill occurs; these percent chances increase slightly to 26% and 14%, respectively, in summer 90 days after a large oil spill occurs.

The impacts from a large oil spill could be felt by communities far removed from launch points in the Proposed Action Area (Galginaitis, 2014b; USDOJ, MMS, 2002). Important subsistence species such as bowhead whales migrating through oiled waters are harvested by communities located far from the Proposed Action Area. Concerns about reduced subsistence harvests and contaminated subsistence foods due to a possible large spill would most likely be shared by all communities in the NSB that hunt bowhead whales. Such concerns would most likely be accompanied by long lasting and widespread stress and worry in bowhead whaling communities across Alaska. If the Cross Island whaling area were contacted by a large spill, these psychological effects would be severe and thus major for most residents of Nuiqsut.

Bowhead whales hunted by Nuiqsut from their basecamp on Cross Island could suffer irritation and illnesses as a result of a large oil spill. Some individual whales could directly encounter and contact oil in the Beaufort Sea if a large spill occurred and contacted bowhead habitat during the fall migration (Neff, 1990; USDOJ, MMS, 2002). It is likely that some of these whales would experience temporary and nonlethal effects. Potential harm to bowhead whales from contact with spilled oil is considered a concern due to certain anatomical characteristics of the bowhead whale such as extensive baleen that could be fouled by spilled oil, roughened areas of skin that may be sensitive to oil, extensive conjunctival sacs around the eyes that could be irritated by contact with oil, inhalation of toxic vapors while surfacing in spilled oil, and a narrow channel connecting stomach chambers that could be blocked by ingested oil; spilled oil could damage these organs in bowhead whales and the overall health of individual whales, especially along the edge of the sea ice or in ice leads where bowheads could contact spilled oil for longer durations or in higher concentrations than in open pelagic conditions (Burns and Bennett, 1987; Geraci and St. Aubin, 1990; National Research Council, 2003, p. 102; USACE, 1999). The health and nutritional well-being of individual whales could be compromised if large amounts of oil or contaminated prey were ingested while feeding. Prolonged exposure of large numbers of feeding bowhead whales concentrated in high prey density could be exposed to prolonged oil contact and experience moderate effects, including mortality of some individuals and impaired physiological function and reproductive capacity (Section 4.3.4.1.1).

As a result of actual and perceived contamination, bowhead whales could be unavailable for harvest for one or more seasons (USDOJ, MMS, 2002). Tainting concerns in communities nearest the spill event could substantially curtail traditional practices of harvesting, sharing, and processing bowheads for one or more seasons. Severe loss of opportunity to practice traditional subsistence whaling would threaten the foundations of Iñupiaq culture, identity, and social organization in the affected communities and could result in major impacts to Cross Island whaling.

There also is concern that the International Whaling Commission, which sets the quota for the subsistence harvest of bowhead whales, would reduce the harvest quota following a major oil spill as a precaution to ensure that overall population mortality did not increase (Galginaitis, 2014b; USACE, 1999; USDOJ, MMS, 2002). Depending on the size of the reduction, a lower bowhead quota could have moderate to major impacts on food security, social organization, and cultural identity for Iñupiaq whaling communities. Whaling communities distant from and unaffected by potential spill effects are likely to share bowhead whale products with impacted villages when successful.

Oil contamination of beaches used for whaling in fall or sea ice used for whaling in spring could have a major impact on whaling because even if bowhead whales were not directly contacted and contaminated, subsistence whalers would not be able or willing to bring them ashore and butcher them on contaminated beaches or sea ice (Galginaitis, 2014b). This would most likely persist for one or more seasons or until beaches were adequately cleaned and restored and could result in major impacts.

The duration of avoidance of bowhead whales by subsistence whalers would vary depending on the volume of the spill, persistence of oil in the environment, degree of impacts on resources, time necessary for spill response and recovery, and the confidence that resources were once again safe to harvest, share, and eat. All whaling communities would share concerns over the safety of bowhead food products and the health of the whale stock in the event of a large crude or refined oil spill.

If a large spill occurred in Nuiqsut's whaling territory, effects on bowhead whaling could be severe and thus major for the Cross Island whalers. This is especially the case for the open-water season during August through September.

Impacts of a large spill on subsistence bowhead whaling for Kaktovik could be moderate to major depending on the trajectory of the spill. For the summer season, July 1 through September 30, the percent chance of oil contacting Kaktovik's whaling area is only 1% from launch points on the proposed LDPI, 30 days after the spill. Ninety days after a large spill occurred, the percent chance of Kaktovik's whaling area being oiled from proposed LDPI and pipeline sources remains 1%.

For Utqiaġvik, impacts of a large spill on subsistence bowhead whaling could be moderate to major depending on the trajectory and timing of the spill. For the summer season, July 1 through September 30, the percent chance of oil contacting the eastern portion of Utqiaġvik's whaling area is 4% from launch points on the island, 90 days after the spill and 2% from launch points at the pipeline. Effects on whaling from a large spill for Utqiaġvik crews would most likely only occur during the fall season.

Spill response and cleanup activities could include mechanical recovery methods, use of dispersants, and in-situ burning of spilled materials. Increased aircraft and vessel traffic, and corresponding increases in vessel discharges and noise, would be associated with spill cleanup operations.

If clean-up operations include sections of beaches, access to butchering sites and areas could be temporarily restricted.

Subsistence harvest patterns could be adversely affected by spill response and cleanup activities that involved volunteer or paid employment of local subsistence harvesters, by diverting time, effort, and equipment away from subsistence activities such as whaling to oil spill response and cleanup. Earning cash from paid work in spill response and cleanup may allow some subsistence harvesters to purchase newer equipment and fuel needed to effectively pursue subsistence activities.

Depending on the size of the spill and whether or not it contacted onshore and offshore subsistence resources, response and cleanup duration and impacts could be short-term and localized or long lasting and widespread.

Mechanical methods used to recover spilled oil offshore could impact whaling practices and other subsistence harvest patterns. The use of chemical dispersants and in-situ burning would most likely

result in perceptions of environmental contamination and tainting of subsistence resources that could last for one harvest season or longer. Perceptions of contamination and actual contamination of resources could result in cessation of subsistence harvest of marine resources including bowhead whales.

Impacts to subsistence harvest patterns caused by spill response and cleanup activities are expected to be minor to moderate depending on the extent and location of the spill. Minor to moderate effects from spill response and cleanup are not expected to change the overall impact conclusions for a large spill.

Government initiated unannounced exercises (e.g., oil spill drills), which are infrequent, of short duration, (<8 hours), and utilize existing equipment, would not alter impact conclusions for subsistence activities and harvest patterns.

Summary of Effects for Whaling

BOEM found potential temporal and spatial overlap between subsistence whaling activities and the Proposed Action for Nuiqsut crews, particularly proposed LDPI construction activities scheduled for late spring and summer (Table 4.4.3-2).

Impacts to subsistence whaling from possible deflection of some whales seaward are expected to be moderate. Alteration of whale movements that could potentially impact whaling practices would most likely only occur inside the barrier islands in or near the Proposed Action Area.

Impacts to Cross Island whaling related to the presence of and potential disturbances from support vessel traffic are expected to be moderate.

Impacts due to whaler avoidance of the Proposed Action Area are expected to be major. It is important that the Proposed Action Area be available for scouting in case whales are not readily found where they are usually expected to be north and east of Cross Island. This is especially the case during times when ice and weather conditions prevent whalers' access to the open water seaward of the barrier islands. Whalers may avoid the Proposed Action Area if whales there become undesirable due to beliefs that whales are contaminated as a result of operations.

Effects of summer construction activities related to LDPI slope protection are expected to be major. Nuiqsut whalers may avoid the Proposed Action Area for the entire whaling season due to noise and presence of construction activities if slope protection activities occur through the end of August.

Impacts to Cross Island whaling from small spills of crude or refined oil are expected to be minor to major. Moderate impacts to subsistence whaling practices could result from negative perceptions of tainting of whales as a result of small spills. Although unlikely, major impacts could occur if a small spill contacted the shore of Cross Island during a whaling season.

Effects to subsistence whaling for Nuiqsut crews from large oil spills are expected to be major. A large spill that affects any part of the migration route of bowhead whales could injure and taint whales, which are culturally paramount to the Iñupiat people of the NSB. Even if whales were available for the spring and fall hunts, tainting concerns could leave bowheads less desirable and disrupt or stop subsistence whaling practices for one or more seasons, resulting in severe and thus major impacts to subsistence whaling practices in these communities. Depending on the extent of the oil spill and degree of response and cleanup activities, a large oil spill could adversely affect all Alaskan whaling communities.

Conclusions for Whaling

Appendix C describes mitigation measures derived from lease stipulations, design features and BMPs the operator committed to, and requirements and BMPs that other agencies typically require (sections

C-1 to C-3). BOEM's conclusions regarding impacts assume implementation and compliance with the mitigation measures described in sections C-1 through C-3.

Potential impacts to subsistence whaling for Nuiqsut are related to: possible alteration of movement patterns of some whales present inside the barrier islands; stress and worry over alteration of whale movement patterns on the part of whalers; support vessel traffic; summer construction activities such as sheet pile driving; and whaler avoidance of the Proposed Action Area. Overall, potential adverse effects to Cross Island subsistence whaling activities and harvest practices from routine activities could range from moderate to major primarily due to potential social, cultural, and psychological impacts related to whaling practices, beliefs, and traditions of the whalers regarding noise and industrial development in the marine environment. These potential impacts to the human environment are independent of potential negligible biological impacts to bowhead whales. (See Section 4.3.4.1.1 for a discussion of potential biological effects.) These potential impacts to the human environment are related to the relationship of people with that environment and the relationship of the Iñupiat people with the whale.

Effects to Cross Island subsistence whaling activities and harvest practices would primarily occur in August through September during the open-water season at times corresponding to the fall whaling season. Winter activities, other than oil spills, such as gravel mining, proposed LDPI construction in winter, pipeline construction, and ice road construction and maintenance are expected to have little to no impacts to subsistence whaling practices.

Although Kaktovik would most likely be whaling in late August and early September, their crews' core whaling area does not spatially overlap with the Proposed Action Area. BOEM expects negligible impacts to Kaktovik's whaling activities and harvest patterns from proposed LDPI construction, pipeline construction, facilities construction, drilling, production, and decommissioning. Small spills are expected to have negligible impacts on Kaktovik's whaling season. Large oil spills could have moderate to major impacts on bowhead whaling practices conducted by Kaktovik whaling crews.

BOEM found no spatial overlap between the Proposed Action and spring or fall bowhead whaling conducted by crews living in Utqiagvik. The Proposed Action is not expected to have direct effects on Utqiagvik's subsistence whaling activities and thus impacts would most likely be negligible. Small oil spills are expected to have negligible impacts on Utqiagvik's whaling seasons. A large oil spill could have moderate to major impacts on the fall bowhead whaling hunt conducted by Utqiagvik crews.

Most of the potential effects to Cross Island whaling could possibly be reduced or eliminated by implementing carefully planned mitigation measures involving close coordination between Nuiqsut whalers and industry (Appendix C; Kuukpik, 2015; NOAA, 2013, p. 4-211; SRB&A, 2013).

Kuukpik (2015) identified three types of cessation in activities related to the Proposed Action, including cessation periods for marine vessel traffic, drilling, and operating selected equipment on the LDPI during the fall bowhead whale migration. Potential adverse effects to Cross Island subsistence whaling practices from routine activities could be reduced from moderate to major to minor if the cessation periods for sheet pile driving, drilling, and marine vessel traffic during the fall bowhead whale migration were moved back to August 1st or earlier (Kuukpik, 2015, p. 29). Construction, drilling activities, and vessel traffic would be allowed to resume after the Nuiqsut bowhead whale quota of four whales is met or after the whalers officially end their whaling activities for the season.

If LDPI slope protection work is completed by July 25th, there would be little or no impacts to Nuiqsut's whaling season, thereby reducing impacts of summer construction on subsistence whaling from major to negligible. If summer construction activities for LDPI slope protection and associated vessel support traffic cease on August 25th and not continue through the end of August into

September, impacts from summer construction on Nuiqsut's subsistence whaling would most likely be reduced from major to moderate.

Communication centers could be established and subsistence advisors or representatives could be hired to reduce potential conflicts between whaling crews' scouting efforts and support vessels and aircraft traffic during August through September. An improved communications system in conjunction with stipulations minimizing industrial activities known to interfere with whaling can positively affect whaling success (Galginaitis, 2014c, p. 15). Subsistence advisors and communication centers could reduce impacts related to support vessel traffic from moderate to minor. Consultation between the operator and the communities, communication centers, and subsistence advisors would most likely reduce impacts related to whaler avoidance from major to moderate.

To further avoid and reduce potential adverse effects of the Proposed Action to subsistence whaling, Nuiqsut has requested a protection zone in their whaling territory to include the following measures (Kuukpik, 2016, p. 4):

- Establish quiet periods during the whale migration and harvest season for industry vessels and exploration activities
- Designate communication channels and practices by which whalers and industry communicate every six hours to preemptively avoid potential conflicts
- Require industry vessels to use their best efforts to avoid encountering bowhead whales or whalers
- List best practices to be employed by vessels that inadvertently approach a whale
- Establish a dispute resolution process

Seal Hunting

Hunting for bearded and ringed seals is a primary subsistence activity for residents of Nuiqsut, Kaktovik, and Utqiagvik (Section 3.3.3; Table 4.4.3-1; SRB&A, 2010). In general, NSB seal hunters prefer bearded seals to ringed seals, but both species are important for their subsistence ways of life. These two types of seals tend to be hunted in the same areas and during the same timeframe off the central Beaufort coast. Most seal hunting activity is by boat and starts in June, peaks in July, and continues through September in open water as seals follow the ice.

Overlap with the Proposed Action. BOEM found potential for both temporal and spatial overlap of seal hunting activities and the Proposed Action for Nuiqsut and Kaktovik (Table 4.4.3-2). This is the case for summer construction activities proposed to protect the LDPI slope scheduled for May through August during Execute Year 2. For Utqiagvik, there is temporal overlap between proposed LDPI slope protection work and seal hunting but no spatial overlap, therefore no adverse effects from summer construction activities are expected to occur for Utqiagvik's seal hunting practices. BOEM anticipates routine activities, development, production, and decommission for the Proposed Action would have little to negligible impacts on seal hunting practices for residents of Utqiagvik.

During 1996 through 2006, Nuiqsut hunters reported hunting seals between Harrison Bay and Flaxman Island, which broadly overlaps with the Proposed Action Area (SRB&A, 2010). The prime seal hunting area for Nuiqsut is just north of the Colville River Delta and centered on Thetis Island. For Kaktovik hunters, the core seal hunting area is Pokok Lagoon in the east to the Canning River in the west, which is 62 miles east of Foggy Island Bay and the Proposed Action Area. During 1996 through 2006, Kaktovik residents reported hunting bearded seals along the coast as far west as Prudhoe Bay, which broadly overlaps with the Proposed Action Area (SRB&A, 2010).

Although Nuiqsut and Kaktovik have hunted seals in and near the Proposed Action Area, their current core seal hunting areas are substantial distances from the Proposed Action Area. Moreover, hunters tend to look for seals farther off shore than the Proposed Action Area (Section 3.3.3; SRB&A, 2010).

During the 25-year lifetime of the Proposed Action, seal hunting in and closer to the Proposed Action Area may become more popular than it is today if and when seals become unavailable at the core hunting areas closer to Nuiqsut and Kaktovik.

LDPI slope protection

Slope protection is proposed as part of summer construction for the proposed LDPI. This includes cutting a moat in the sea ice around the proposed LDPI, grading the LDPI with a crane and drag line, and installing sheet piling and concrete armament around the proposed LDPI's perimeter (Hilcorp, 2015). The slope protection activities are scheduled for May through August during Year 2 (Figure 2-1; Hilcorp, 2015, p.16). Seal hunting seasons for Nuiqsut and Kaktovik primarily occur June through September (Table 4.4.3-1) and would be most at risk from potential impacts caused by slope protection work in summer. The 2018 seal hunting seasons for Nuiqsut and Kaktovik will most likely start in May or June. Seal hunting will continue through September. The potential effects could be disturbance of seal hunters due to construction noises, conflicts between seal hunting boats and support vessels, disturbances from helicopter overflights; and avoidance of the Proposed Action Area due to summer construction activities thereby potentially reducing seal hunting opportunities for the Execute Year 3 open-water season. However, seals would not become unavailable for one or more seasons, and hunters would have continued opportunities to go hunting for seals in areas closer to Nuiqsut and Kaktovik at the core seal hunting areas. Noises and disturbances from slope protection work and associated support vessel and aircraft traffic could result in short term and localized and thus minor impacts to subsistence seal hunting for Nuiqsut and Kaktovik. This would especially be the case if hunters need to look for seals in the Proposed Action Area in July and August 2018 if seals were not available closer to home.

Oil spills and spill response

Small spills are unlikely to affect individual seals, because small spills cover a small area and are less likely to persist in the environment (Section 4.1.1.1; USDOJ, MMS, 2002). Small spills starting at the proposed LDPI or the pipeline would most likely not reach the main ice habitat areas of bearded and ringed seals due to rapid dispersal and evaporation within hours to a few days. BOEM expects the number of seals potentially affected by small spills as a result of the Proposed Action to be negligible.

If small spills occurred during the main seal hunting season, June through September, seal hunters from Nuiqsut and Kaktovik could experience negative perceptions of tainted seals. Seal hunters would most likely be concerned that any seals traveling through the Proposed Action Area could be contaminated as a food source due to small spills. If small spills contacted the shoreline of Thetis Island during the seal hunting season, subsistence seal hunting at the island could be temporarily disrupted because hunters would be unable or unwilling to camp and hunt seals there due to the fear of contaminated resources and oiled beaches. The impacts to subsistence seal hunting would be short term and localized and thus minor and hunters would be able to pursue seals at different areas. The effects of perceptions of tainted seals would most likely be longer lasting and widespread and thus moderate. However, small spills originating in the Proposed Action Area would most likely not reach Thetis Island due to relatively fast dispersion and evaporation.

BOEM anticipates that small spills would have a negligible impact on seal hunting for Utqiagvik hunters because there is no spatial overlap between the Proposed Action Area and the core seal hunting area for Utqiagvik.

Although an unlikely event, BOEM assumes that one large spill of crude or refined oil could occur during the life of the Proposed Action. Appendix A shows the percent chance of oil contacting subsistence resource areas from a large spill starting at the proposed LDPI and the pipeline. Nuiqsut's main seal hunting area, Thetis Island north of the Colville River Delta, would have a chance of being contacted by a large spill. Thirty days after a large spill launched from the proposed LDPI, Thetis

Island has a 10% chance of being oiled both annually and for the summer season July 1 through September 30. For a large spill starting at the pipeline, Thetis Island has a 4% chance of being contacted thirty days after a large spill occurs both annually and during summer.

If a large spill reached the Thetis Island area and contacted the shoreline of the island, the impacts to subsistence seal hunting could be severe and thus major for Nuiqsut because this is their core seal hunting area. Individual seals could be killed if contacted by oil, but large-scale mortality of seals is unlikely (Geraci and St. Aubin, 1990, p. 255). The seal hunters would most likely stop hunting seals at Thetis Island for one or more seasons due to oiled beaches and actual or perceived contamination of seals and other resources. However, seals would not be completely unavailable. Hunters would be able to pursue seals farther to the west in Harrison Bay or to the east towards Flaxman Island. They could look for seals in the Cross Island area as well but most likely would not do so in late August and early September to avoid disturbing whaling crews. It is possible that a large spill physically affecting Thetis Island would also contact these alternative seal hunting areas, thereby further limiting seal hunting opportunities. Perceptions of tainting and worry about contaminated seals would most likely be long lasting and severe due to a large spill for the entirety of Nuiqsut's seal hunting territory.

Kaktovik's core seal hunting area is less likely to be contacted by a large spill originating at the Proposed Action Area. The Canning River Delta and Kaktovik's core offshore seal hunting and whaling areas only have a 1% chance of contact in the event of a large spill starting at the proposed LDPI in summer. In the event of a large spill, Kaktovik hunters would most likely avoid the western portion of their seal hunting area between Prudhoe Bay and Flaxman Island, which would limit their seal hunting opportunities closer to town in the core area; the effects of which are expected to be short term and localized and thus minor. However, a large spill could cause long lasting and widespread and thus moderate impacts related to psychological stress and perceived and actual contamination of seals as a food source for one or more hunting seasons.

For the summer season July 1 through September 30, the eastern portion of Utqiagvik's core seal hunting area has a 4% chance of being contacted by a large spill starting at the proposed LDPI and a 2% chance of contact from a large spill starting at the pipeline, 90 days after the event. The western portion of their core seal hunting area has no chance of contact from a large spill originating at the Proposed Action Area. In the event of a large spill, some Utqiagvik seal hunters may temporarily avoid the eastern part of their territory for one or more seasons, but they would continue to have seal hunting opportunities to the west and south in the Peard Bay area and farther seaward to the north off Point Barrow. Many hunters would most likely look for seals east of Point Barrow unless a large spill physically contacted that area. For seal hunting conducted by Utqiagvik hunters, BOEM expects short term and localized and thus minor impacts from a large spill. However, a large spill could cause long lasting and widespread and thus moderate impacts related to psychological stress for Utqiagvik seal hunters regarding potential contamination of seals as a food source for one or more hunting seasons.

Seal hunting practices could be adversely affected by spill response and cleanup activities that involved volunteer or paid employment of local subsistence hunters by diverting time, effort, and equipment away from seal hunting to oil spill response and cleanup for one or more seasons. Earning cash from paid work in spill response and cleanup could allow some subsistence sealers to purchase newer equipment and fuel needed to effectively pursue seals and other subsistence activities.

Depending on the size of the spill and whether or not it contacted onshore and offshore subsistence resources, response and cleanup duration and impacts could be short-term and localized or long lasting and widespread.

Mechanical methods used to recover spilled oil offshore could impact seal hunting practices at Thetis Island or other important seal hunting areas. The use of chemical dispersants and in-situ burning would most likely result in perceptions of environmental contamination and tainting of seals that could last for one harvest season or longer. Perceptions of contamination and actual contamination of

seals due to spill response and cleanup could result in cessation of seal hunting or avoidance of hunting areas for one or more seasons.

Impacts to subsistence seal hunting caused by spill response and cleanup activities are expected to be minor to moderate depending on the extent and location of the spill. Minor to moderate effects from spill response and cleanup are not expected to change the overall impact conclusions for a large spill.

Conclusions for seal hunting

Overall, LDPI slope protection work at the Proposed Action Area is expected to have minor impacts on seal hunting for Nuiqsut and Kaktovik and negligible impacts on seal hunting for Utqiagvik. Other routine activities associated with the Proposed Action are not expected to have adverse effects on seal hunting for any North Slope community.

If Hilcorp ends summer construction activities and related support vessel traffic at the proposed LDPI site July 25 instead of extending the LDPI slope protection work through August, impacts to seal hunting for Nuiqsut and Kaktovik would most likely be reduced from minor to negligible. If Hilcorp ended construction for LDPI slope protection August 25, the impacts to seal hunting would most likely not be reduced and would remain minor.

Small spills associated with the Proposed Action are expected to have minor to moderate impacts on seal hunting for Nuiqsut and Kaktovik. For Utqiagvik seal hunters, impacts from small spills at the Proposed Action Area would be negligible.

A large spill could result in major impacts to seal hunting for Nuiqsut. For Kaktovik and Utqiagvik, a large spill is expected to have minor to moderate impacts on subsistence seal hunting.

Caribou Hunting

Caribou are an important subsistence resource for the residents of Nuiqsut, Kaktovik, and Utqiagvik and provide large amounts of subsistence foods and other materials year round (Section 3.3.3; Table 4.3.5-2; Braem et al., 2011; Galginaitis, 2014b; SRB&A, 2010). For these communities, caribou hunting generally peaks in July and August and tapers off in September (SRB&A, 2010). June is also an important month for caribou hunting for Utqiagvik and Nuiqsut (Braem et al., 2011; SRB&A, 2010). In summer, caribou are generally hunted by boat, in river deltas and along the coastline or shores of barrier islands where caribou congregate for relief from insects and heat. In winter, caribou are primarily hunted inland near communities using snowmachines, but at times coastal areas have been used in winter for caribou, especially by Kaktovik hunters (Pedersen, 1990b; SRB&A, 2010).

Overlap with the Proposed Action. BOEM found temporal overlap between subsistence caribou hunting and the Proposed Action for Nuiqsut, Kaktovik, and Utqiagvik (Table 4.3.5-2). With exception of an unlikely large oil spill, BOEM did not find spatial overlap between caribou hunting activities and the Proposed Action for Nuiqsut and Utqiagvik (Braem et al., 2011; SRB&A, 2010). For routine construction, development, production, and decommissioning activities, BOEM anticipates little to no and thus negligible impacts to subsistence caribou hunting for Nuiqsut and Utqiagvik.

Kaktovik hunters harvest caribou year round, and they harvest most of their caribou in July and August; they tend not to harvest caribou in June during calving and October during rut (Pedersen, 1990b; SRB&A, 2010). The timing of winter and summer construction activities for the Proposed Action potentially overlap with both winter and summer caribou hunting. Kaktovik hunters use coastal areas in both winter and summer for caribou hunting.

BOEM found the Proposed Action Area potentially overlaps spatially with the western portions of Kaktovik's historical caribou hunting area (Table 4.3.5-2). Kaktovik residents reported hunting caribou along the coast and barrier islands as far west as Prudhoe Bay with some caribou use areas as

far west as the Ikpikpuk River and around the shores of Teshekpuk Lake (NSB, 2014; SRB&A, 2010). Caribou hunters from Kaktovik sometimes hunt in coastal areas during summer months near Flaxman Island and occasionally farther west to the Shavirovik River and Foggy Island inside the Proposed Action Area (LGL Alaska et al., 1998; NSB, 2014; SRB&A, 2010).

Hunters from Kaktovik seldom expect to use this entire area, and they prefer to avoid areas of industrial development to the west of Flaxman Island while hunting caribou. However, during the 25-year life of the Proposed Action, they could foreseeably use the western portions of their historical caribou hunting area located in the Proposed Action Area if and when caribou are not present near the community or in the core hunting area. The core caribou hunting area for Kaktovik is a smaller area along the coast between Bullen Point in the west and the US-Canada border in the east (Table 4.3.5-2; Galginaitis, 2014b; SRB&A, 2010). Bullen Point is approximately two miles east of the Proposed Action Area.

Effects on Caribou Resources

Disturbance can displace and divert caribou away from habitats or routes that would normally be used by caribou and subsistence harvesters (Section 4.3.5.1.1; Hilcorp, 2015, Appendix A; SRB&A, 2009). Construction of the gravel mine and proposed LDPI and installation of the offshore and onshore segments of the pipeline during winter should minimize potential disturbance impacts because fewer caribou are present in the Proposed Action Area in winter and fewer hunters use coastal areas in winter for caribou hunting (Section 4.4.5.1.1). Noise disturbance would be greatest during gravel mine construction with blasting only occurring during one winter. However, most caribou leave the coastal plain by late September to migrate to wintering areas in or south of the Brooks Range. The most likely response from caribou to active gravel mining would be avoidance by around 2.4 km during times of active gravel extraction. The temporary and non-injurious impacts of gravel mining negligible levels of effect on caribou (Section 4.3.5.1.1).

During winter construction, transportation would generally require for vehicles over ice roads or helicopters. Trucks would use ice roads to access Foggy Island Bay, the pipeline, gravel mine site, freshwater sources, and the proposed LDPI site. Approximately 400 trips by vehicles of various types and function are proposed during the winter construction season to haul gravel to build the proposed LDPI (Hilcorp, 2015). Construction of the tie-in gravel pad and installation of the onshore portion of the pipeline would create onshore winter traffic. These activities could potentially cause short-term and localized noise disturbance and displacement of small numbers of caribou wintering in the Proposed Action Area. Disturbance may cause flight reactions and decreased foraging for caribou, resulting in increased energy expenditures that could cause minor impacts to individual caribou but are not expected to affect overwinter survival of caribou.

The greatest potential for disturbance to caribou from the Proposed Action would be the increase in air and vehicle traffic from Deadhorse and on the Endicott Road. Low-level helicopter overflights for routine maintenance and surveillance of the pipelines may cause caribou to flee the area, especially for maternal caribou and large groups of caribou; this disturbance would cause the animals to expend extra energy (Hilcorp, 2015, Appendix A). Potential summer construction activity at the Endicott Satellite Drilling Island (SDI) would create increased traffic on the Endicott Road during gravel hauling. Increased summer traffic may lead to an increase in disturbance to caribou moving through the Sagavanirktok River Delta.

Most ground and air traffic from Deadhorse to the proposed LDPI would cross through the middle of the Sagavanirktok River Delta; the potential for disturbance to animals using the delta would be present during all seasons, but it would be greatest during spring and summer. Caribou are most sensitive to disturbance and displacement from preferred habitats early during the calving period late May and early June. Helicopter overflights could cross caribou calving concentrations between the

Sagavanirktok and Canning rivers, but Hilcorp (2015, Appendix A) expects that this would be unlikely and most calving locations would be expected to be east of this potential overflight area.

Effects on Summer Caribou Hunting

For summer caribou hunting by residents of Kaktovik, potential impacts of the Proposed Action include disturbance to or displacement of groups of caribou and hunters in coastal areas due to helicopter overflights. Helicopters would be used in support of LDPI slope protection work scheduled for May through August during Execute Year 2. Work activities for the reclamation of the gravel mine in May through September of Execute Year 1 just south of Foggy Island Bay could also disturb or displace caribou and hunters from Kaktovik. Support vessel traffic coastward of the barrier islands could conflict with boat travel by caribou hunters from Kaktovik in Foggy Island Bay.

Potential impacts to caribou hunting would most likely occur in July and August in coastal areas between Prudhoe Bay and Mikkelsen Bay and would most likely result from helicopter operations. Hovercraft would access the proposed LDPI year-round (Hilcorp, 2015). Hilcorp (2015a) proposed year-round helicopter access to the proposed LDPI with air operations limited by weather conditions and visibility. Air access to the island would be used for routine movements of personnel, equipment, supplies such as food, and pipeline surveillance and maintenance. Air traffic is proposed to take direct routes from West Dock, SDI, or Deadhorse to the proposed LDPI. During construction, Hilcorp (2015a) proposed 1 to 2 helicopter and 3 hovercraft round-trips per day, 2 helicopter and 2 hovercraft round-trips per day during drilling, and 1 to 2 helicopter and 2 hovercraft round-trips per day during production. Hilcorp has proposed to adjust routes and flight altitudes to accommodate weather, air traffic, and subsistence activities.

If during the 25-year life of the Proposed Action, caribou hunters from Kaktovik travel to Foggy Island or Prudhoe Bays by boat and encounter helicopter overflights, the impacts to the hunt could be minor or moderate depending on the number of hunters affected and to what extent they associate their success or lack thereof with the aircraft encounter. If caribou are observed but no caribou are harvested because they were driven away by a helicopter, impacts could be long lasting and widespread, especially after travelling such a great distance by boat in search of meat for the community. If the same scenario occurred with only one boat travelling through the Proposed Action Area for other purposes or if no caribou were present when the encounter occurred, the effects would most likely be short term and localized.

The likelihood of Kaktovik hunters travelling to the Proposed Action Area to purposively hunt caribou is low during the life of the Proposed Action. BOEM anticipates that Kaktovik caribou hunters would have opportunities to find and successfully harvest caribou in the core area to the east of the Proposed Action Area and would only rarely travel west of Flaxman Island or to shores of Foggy Island Bay to harvest caribou during the life of the Proposed Action. Caribou should not be unavailable as a result of the Proposed Action for one or more seasons. BOEM expects little to no effects to summer caribou hunting as a result of LDPI slope protection activities, gravel mine reclamation, and support vessel traffic. Overall, BOEM expects impacts from the Proposed Action on summer caribou hunting for Kaktovik to be negligible.

Effects on Winter Caribou Hunting

For winter caribou hunting by residents of Kaktovik, potential impacts of the Proposed Action could result from ice road construction and maintenance; gravel mining and hauling; helicopter support flights for proposed LDPI construction and offshore pipeline installation; onshore pipeline construction; and decommissioning of the onshore pipeline and gravel pads. These work activities are proposed for months between December and April when Kaktovik hunters go for caribou using snowmachines. Hunters can cover about 200 miles a day on snowmachine while hunting and tend to do most of the caribou hunting during day trips where they return to town each day (NSB, 2014;

SRB&A, 2010). Kaktovik hunters prefer to hunt close to home but will spend time and resources to travel farther when necessary.

Groups of caribou and hunters would most likely be temporarily displaced from the Proposed Action Area during these construction activities. If during the 25-year life of the Proposed Action, caribou hunters from Kaktovik travel to the Foggy Island Bay area by snowmachine and encounter helicopter overflights or trucks hauling gravel, the impacts to the hunt could be minor or moderate depending on the number of hunters affected and to what extent they associate their success or lack thereof with disturbances from winter construction activities and support vehicles or aircraft. If caribou are observed but no caribou are harvested because they were driven away from hunters by a helicopter or support vehicle, impacts could be long lasting and widespread, especially after travelling substantial distances by snowmachine in search of meat for the community.

Caribou that overwinter on the coastal plain sometimes use the coast and near shore sea ice as a salt lick. Potential impacts to subsistence hunting would be limited to coastal areas in the far western portions of Kaktovik's caribou hunting area, which would most likely only be used if caribou were not found closer to town in the core hunting area or at inland areas that are more popular for hunting caribou in the winter. BOEM does not expect that caribou would be unavailable to Kaktovik hunters for an entire winter season or more because of winter construction activities and support vehicle and helicopter traffic. Therefore BOEM expects little to no and thus negligible impacts to winter caribou hunting for Kaktovik as a result of the Proposed Action.

Oil Spills and Spill Response

Small spills occurring offshore are unlikely to affect individual caribou unless a small spill contacted shorelines and barrier islands in July and August when caribou are present for insect relief. Small spills are not expected to contact beaches or shorelines of barrier islands because they cover a small area and are less likely to persist in the environment (USDOI, MMS, 2002).

Small spills that occur onshore are not expected to affect individual caribou or groups of caribou because caribou most likely would avoid construction and development areas while work is ongoing. After construction has ceased, caribou may use elevated gravel pads to get into the wind to avoid biting insects and could potentially contact a small spill from a pipeline. Caribou hunters from Nuiqsut and Kaktovik would most likely avoid the construction and development areas during all times of year unless they had no other options to take caribou, which is unlikely. BOEM expects the number of caribou potentially affected by small spills as a result of the Proposed Action to be negligible. In the event that individual caribou were contacted by a small spill, the impacts on caribou are expected to be short term and localized and thus minor.

If small spills occurred during the main caribou hunting season, June through August, caribou hunters from Nuiqsut and Kaktovik could experience negative perceptions of tainted caribou. Hunters would most likely be concerned that caribou traveling through or using the Proposed Action Area could be contaminated as a food source due to small spills. The effects of perceptions of tainted caribou could be long lasting and widespread and thus moderate. However, the overall impacts to subsistence caribou hunting for Nuiqsut and Kaktovik from small spills would most likely be negligible as hunters would be able to pursue caribou at different areas outside the Proposed Action Area.

BOEM anticipates small spills would have a negligible impact on caribou hunting for Utqiagvik hunters because there is no spatial overlap between the Proposed Action Area and the core caribou hunting area for Utqiagvik (Braem et al., 2011; SRB&A, 2010).

Although an unlikely event, BOEM assumes that one large spill of crude or refined oil could occur during the life of the Proposed Action. Nuiqsut's main caribou hunting area, the Colville River Delta, would have a small chance of being contacted by a large spill. The Colville River Delta has a 3% chance of being contacted within 90 days after a large oil spill occurred at any point during the year

(January 1 through December 31). If a large oil spill occurred during the winter (October 1 through June 30), there is a 2% chance that Colville River Delta would be contacted within 90 days. If a large spill, originating from the proposed LDPI, were to occur in the summer (July 1 through September 30), the Colville River Delta has a 6% chance of being oiled within thirty days. For a large spill originating at the pipeline during the summer, the Colville River Delta has a 3% chance of being oiled within 30 days.

In July and August, the Colville River Delta is important for Nuiqsut caribou hunting. Although unlikely, if a large spill contacted the Colville River Delta in summer while caribou were present or if a large spill diverted caribou away from the delta in summer, the impacts to caribou hunting for Nuiqsut could be severe and thus major. A large spill in this area could severely disrupt subsistence caribou hunting or make caribou unavailable or undesirable for one or more seasons. Negative perceptions of contaminated caribou as a food source would most likely result in long lasting and widespread and thus moderate psychological stress in Nuiqsut.

There is a higher percent chance of contact from a large spill of crude or refined oil for the larger insect relief and calving area along the coast used by the Central Arctic Caribou Herd (CAH), which overlaps with portions of the caribou subsistence use areas for Nuiqsut and Kaktovik (Appendix A). The extent of this caribou use area (GLS-174) is large, extending from the Colville River Delta in the west to the Canning River Delta in the east. If a large spill originating from the proposed LDPI occurred in the summer (July through September), there is a 42% chance that oil could contact this stretch of coastline within 30 days. The chance of contact from a large spill starting from the pipeline in summer increases to 47% thirty days after a large spill. If the location and time of contact of oil spilled offshore corresponded to the time and location of caribou presence there could be moderate effects to individual caribou, especially if individuals were directly oiled. A large spill originating from the onshore pipeline could have short term and localized effects on individual caribou and caribou hunting; in the event that individual caribou were oiled, effects to caribou could be moderate but less than severe because the entire herd would not be at risk of decline from loss of habitat or large-scale mortality due to a large spill.

If contact of spilled oil corresponded in time and place with caribou hunting for Nuiqsut or Kaktovik hunting parties hunting with boats along the shoreline, there could be long lasting and widespread and thus moderate impacts to subsistence caribou hunting. Impacts to caribou hunting would most likely not be major because hunters from both Nuiqsut and Kaktovik would have alternate places to look for caribou; Nuiqsut could hunt to the west of the Colville River Delta and farther inland, and Kaktovik hunters could hunt in coastal areas east of the Canning River along the shores of Camden Bay. The effects of actual and perceived contamination of caribou in the CAH as a food source due to a large spill contacting important caribou habitat and forage would most likely be long lasting and widespread and thus moderate for hunters and other residents of Nuiqsut and Kaktovik.

Kaktovik's core caribou hunting areas farther east of the Proposed Action Area are less likely to be contacted by a large spill originating at the Proposed Action Area. The Canning River Delta and the insect relief and overlapping subsistence use area for the Porcupine Caribou Herd only have a 1% chance of contact in the event of a large spill starting at the proposed LDPI in summer thirty days after a large spill. In the event of a large spill contacting the coastline or tundra in the Proposed Action Area, Kaktovik hunters would most likely avoid the western portion of their caribou hunting area between Prudhoe Bay and Flaxman Island, which would limit their caribou hunting opportunities closer to town in the core area; the effects of which are expected to be short term and localized and thus minor.

For a large spill occurring in the summer season (July 1 through September 30), the eastern portion of Utqiagvik's caribou hunting area has a 5% chance of being contacted by a large spill starting at the proposed LDPI and a 3% chance of being contacted from a large spill starting at the pipeline within

90 days after the event. In the event of a large spill, some Utqiaġvik caribou hunters may temporarily avoid the eastern part of their territory for one or more seasons, but they would continue to have caribou hunting opportunities to the west and south along the Chukchi coast in the Peard Bay area. Many hunters would most likely look for caribou east of Utqiaġvik unless a large spill physically contacted that area. For caribou hunting conducted by Utqiaġvik hunters, BOEM expects short term and localized and thus minor impacts from a large spill. However, a large spill could cause long lasting and widespread and thus moderate impacts related to psychological stress for Utqiaġvik caribou hunters and other residents regarding potential contamination of caribou as a food source for one or more hunting seasons.

Caribou hunting practices could be adversely affected by spill response and cleanup activities that involved volunteer or paid employment of local subsistence hunters by diverting time, effort, and equipment away from caribou hunting to oil spill response and cleanup for one or more seasons. However, earning cash from paid work in spill response and cleanup could allow some caribou hunters to purchase newer equipment and fuel needed to effectively pursue caribou and other subsistence activities.

Depending on the size of the spill and whether or not it contacted onshore and offshore subsistence resources, response and cleanup duration and impacts could be short-term and localized or long lasting and widespread.

Mechanical methods used to recover spilled oil offshore would most likely not affect caribou hunting. The use of chemical dispersants and in-situ burning would most likely not affect caribou hunting but could result in perceptions of environmental contamination and tainting of caribou and other food resources that could last for one harvest season or longer. Perceptions of contamination of caribou due to spill response and cleanup most likely would not result in cessation of caribou hunting or avoidance of hunting areas for one or more seasons. In the event of coastal or tundra oiling, shoreline and tundra cleanup and restoration activities could haze caribou away from oiled areas potentially reducing chances of caribou coming into direct contact with spilled crude or refined oil.

Impacts to subsistence caribou hunting from spill response and cleanup activities are expected to be minor to moderate depending on the extent and location of the spill. Minor to moderate effects from spill response and cleanup are not expected to change the overall impact conclusions for a large spill.

Conclusions for Caribou Hunting

Overall, BOEM expects negligible impacts to subsistence caribou hunting for Nuiqsut, Kaktovik, and Utqiaġvik from routine construction, development, production, and decommissioning activities associated with the Proposed Action.

Overall, BOEM expects minor impacts to individual caribou could occur as a result of the Proposed Action. Potential minor effects to caribou could result from helicopter overflights and winter construction activities.

If industry pilots maintain altitudes above 1,500 feet and do not approach groups of caribou and caribou hunters, minor and negligible impacts to from helicopter overflights to caribou and subsistence caribou hunting and minor impacts to individual caribou would most likely be eliminated.

The overall impacts to subsistence caribou hunting for Nuiqsut and Kaktovik from small spills would most likely be negligible as hunters would be able to pursue caribou at different areas outside the Proposed Action Area. BOEM anticipates small spills would have a negligible impact on caribou hunting for Utqiaġvik hunters because there is no spatial overlap between the Proposed Action Area and the core caribou hunting area for Utqiaġvik.

For a large spill of crude or refined oil resulting from the Proposed Action, BOEM anticipates moderate to major impacts to subsistence caribou hunting for Nuiqsut and minor to moderate impacts on caribou hunting for Kaktovik and Utqiagvik.

Subsistence Fishing

Fishing is a major component of the annual subsistence rounds of Nuiqsut, Kaktovik, and Utqiagvik. The primary species of importance for these communities include Arctic cisco, Arctic char, and broad whitefish (Section 3.3.3; Table 4.3.2-1; SRB&A, 2010).

Overlap with the Proposed Action. BOEM found some temporal overlap between subsistence fishing and the Proposed Action (Table 4.3.2-2). In general, winter construction and development activities would occur at the same time Utqiagvik and Nuiqsut go fishing for Arctic cisco. Summer and fall construction and development activities would overlap in time with Kaktovik's main fishing seasons for Arctic cisco, Arctic char, and broad whitefish. Summer and fall construction and development activities would overlap in time with the Arctic char and broad whitefish seasons for Utqiagvik and Nuiqsut.

BOEM found no spatial overlap between the Proposed Action Area and subsistence fishing areas for Arctic cisco, Arctic char, and broad whitefish for Nuiqsut, Kaktovik, and Utqiagvik. The far western portion of Kaktovik's fishing area is along the coast near Flaxman Island and is about 35 miles east of the Proposed Action Area (SRB&A, 2010). Residents of Kaktovik harvest Arctic cisco, Arctic char, and broad whitefish in this area. Nuiqsut residents primarily fish for Arctic cisco in the main channels of the Colville River Delta north and west of town with the Nigliq Channel being of particular importance. Nuiqsut residents harvest Arctic cisco and most other fish species approximately 80 miles west of the Proposed Action Area. Utqiagvik's subsistence fishing areas for these species are located approximately 200 miles west of the Proposed Action Area.

For Nuiqsut, Kaktovik, and Utqiagvik, BOEM anticipates negligible impacts to subsistence fishing from routine construction, development, and production activities associated with the Proposed Action.

Potential Effects to Arctic Cisco

Human activities associated with oil and gas development in the nearshore and offshore Beaufort Sea and Colville River Delta have potential to affect Arctic cisco during critical life history stages (ARB, Inc. et al., 2007). Local and traditional knowledge and observations conclude that offshore seismic activities are thought to adversely affect the migration of juvenile Arctic ciscoes; offshore drilling activities are thought to adversely affect feeding and growth of juvenile Arctic ciscoes and subadults in nearshore areas; and river channel crossings, ice bridges, and drilling in winter are thought to adversely impact overwintering Arctic ciscoes in the Colville River Delta (ARB, Inc. et al., 2007).

Environmental factors such as salinity and wind direction appear to affect inter-annual variability in the Arctic cisco population in the Colville River to a greater extent than disturbances from industrial developments (ARB, Inc. et al., 2007). However, there is some evidence that industrial development activities in winter in the Colville River Delta negatively affected survival and catch rates of Arctic ciscoes (ARB, Inc. et al., 2007). This study found that over-wintering survival may have been reduced during the years with the most intense development activities in the Colville River Delta in particular winter construction activities. The study found no obvious effects of offshore seismic activity on total recruitment levels or catch rates for Arctic cisco. A number of residents expressed concerns about hydrocarbon pollutants in cisco; a study of fish tissues from Arctic ciscoes caught in the 2005 subsistence fishery found non-detectable levels of hydrocarbons in all samples (Moulton et al., 2006). ARB, Inc. et al. (2007) found no evidence of any effect of causeways on total recruitment, survival, or catch rates of Arctic cisco.

Winter development activities in the Colville River Delta have the potential to adversely affect Arctic cisco survival (ARB, Inc. et al., 2007). However, the winter construction and development activities planned for the Proposed Action in the Foggy island Bay area are not anticipated to affect the Colville River Delta because there is no spatial overlap between the two. The proposed LDPI is not expected to block the Arctic cisco migration in coastal waters or interfere with summer feeding for Arctic ciscoes (Section 4.3.2). BOEM expects negligible impacts from the Proposed Action to Arctic ciscoes used for subsistence purposes.

Oil spills and spill response

BOEM anticipates negligible impacts on subsistence fishing from small spills associated with the Proposed Action for Nuiqsut, Kaktovik, and Utqiagvik. Small spills would be too far away from the primary subsistence fisheries to have an adverse effect on these subsistence fisheries. Small spills would disperse and evaporate within hours to days before reaching the coastal fisheries or the mouth of the Colville River. Residents of Kaktovik and Nuiqsut would most likely become concerned about tainting of coastal fishes due to reports of small spills. For subsistence fishers and community residents, stress and negative perceptions of contaminated subsistence foods such as Arctic cisco, Arctic char, and broad whitefish could be short term and localized or long lasting and widespread depending on the location of the spill. However, BOEM does not anticipate that small spills would completely shut down any subsistence fishery for one or more seasons or render these subsistence fish inedible.

Nuiqsut's Arctic cisco subsistence fishery would be most vulnerable to a large spill of crude or refined oil during September through December. For the winter season, October 1 through June 30, the subsistence use area at the Colville River Delta has a 2% chance of being contacted by a large spill starting at the proposed LDPI within 90 days after the event. The chance of contact from a large spill originating at the pipeline in winter is 1% for the Colville River Delta 90 days after the spill. Nuiqsut's Arctic char and broad whitefish seasons would be most vulnerable during summer. The chance of contact from a large spill for the Colville River Delta is greater in summer than in winter. During July through September, there is a 6% chance of oil contacting the Colville River Delta within 30 days after a large spill starting at the proposed LDPI and a 3% chance of contact from a large spill originating at the pipeline.

In the unlikely event that a large spill contacted the Colville River Delta during the Arctic cisco fishing season from September through December, impacts to subsistence fishing could be severe and thus major. Oil on and under the ice would most likely deter residents of Nuiqsut from setting their nets under the ice for Arctic ciscoes for one or more seasons. The impacts to the community caused by perceptions of tainting and actual contamination of fish in the Colville River Delta would be major. In summer, Nuiqsut harvesters go farther up river south of town for Arctic char and do not rely on the delta as much as they do for catching Arctic ciscoes in winter. If a large spill contacted the Colville River Delta in summer, effects to subsistence fishing could be long lasting and widespread and thus moderate. The impacts would primarily be associated with actual contamination of whitefish and char as a food source and negative perceptions of tainting. Nuiqsut fishers would be able to fish upstream for Arctic char and whitefishes and would most likely not miss an entire fishing season as a result of a large spill. Arctic char and broad whitefish would be available south of the delta and close to the town of Nuiqsut.

During summer, Kaktovik fishers primarily go for Arctic ciscoes, Arctic char, and broad whitefish along the coastline from Demarcation Bay in the east to Flaxman Island in the west; they also travel inland during winter by snowmachine to harvest Arctic char in the Hulahula River (SRB&A, 2010). During July 1 through September 30, there is <0.5% percent chance of Camden Bay, Barter Island, and Demarcation Bay being contacted by a large oil spill (Appendix A). For Flaxman Island during the summer season, there is a 4% chance of contact with oil starting from a spill on the proposed

LDPI and a 2% chance of contact from a large spill originating from the pipeline within 30 days after the event. There is only a 1% chance of oil contacting the Canning River Delta within 30 days after a large spill starting from the proposed LDPI in summer.

In the unlikely event that a large oil spill contacted the coastal areas of Flaxman Island, the Canning River Delta, Camden Bay, Barter Island, or Demarcation Bay during July 1 through September 30, these subsistence fisheries could be moderately impacted for harvesters from Kaktovik. They would still be able to pursue Arctic char inland on the Hulahula and other rivers in the winter, but a large oil spill in these coastal areas would most likely close down portions of one or more summer fishing seasons, resulting in long lasting and widespread impacts to Kaktovik fishers. This area is large, so if the western part of Kaktovik's fishing grounds was contacted by a large spill, Kaktovik fishers could use the eastern portion closer to the community. These fish species would most likely be available to harvesters from Kaktovik unless the entire coast was oiled. BOEM expects that Kaktovik fishers would not completely lose one or more summer fishing seasons as a result of a large spill from the Proposed Action. BOEM anticipates moderate impacts to subsistence fishing for Kaktovik if a large spill occurs, primarily due to oiled shorelines and negative perceptions of tainting and/or actual contamination of some subsistence fish resources that are important for food and sharing.

Subsistence harvesters from Utqiagvik primarily go fishing for Arctic cisco, Arctic char, and broad whitefish during June through November. With the exceptions of the northwest part of Smith Bay and Elson Lagoon just off Point Barrow, Utqiagvik fishers tend to use inland rivers and lakes feeding Dease Inlet for these subsistence resources (SRB&A, 2010). BOEM does not anticipate that a large oil spill from the Proposed Action would affect the Meade, Inaru, and Chipp rivers that flow into Dease Inlet. For the coastal area of Point Barrow (i.e., Elson Lagoon), 90 days after a large spill event from the proposed LDPI there is only a 2% chance of oiling during July 1 through September 30; this drops to 1% for a large spill launched from the pipeline. In summer, 90 days after an event, Smith Bay has a 1% chance of being contacted from a large spill starting at the proposed LDPI. BOEM anticipates little to no effect and thus negligible impacts to subsistence fishing from a large spill for residents of Utqiagvik.

Subsistence fishing for Arctic cisco, Arctic char, and broad whitefish could be adversely affected by spill response and cleanup activities that involved volunteer or paid employment of local subsistence fishers by diverting time, effort, and equipment away from fishing to oil spill response and cleanup for one or more seasons. However, earning cash from paid work in spill response and cleanup could allow some subsistence fishers to purchase newer boats, motors, and nets and fuel needed to effectively pursue fish in these subsistence fisheries.

Depending on the size of the spill and whether or not it contacted onshore and offshore subsistence resources, response and cleanup duration and impacts could be short-term and localized or long lasting and widespread.

Mechanical methods used to recover spilled oil offshore are not expected adversely affect subsistence fishing. Mechanical recovery and physical cleanup methods used on the shorelines and in nearshore waters in summer could disrupt subsistence fishing for Kaktovik. The use of chemical dispersants and in-situ burning would most likely result in perceptions of environmental contamination and tainting of fishery resources that could last for one harvest season or longer. Perceptions of contamination and actual contamination of fish due to spill response and cleanup could result in cessation of subsistence fishing in coastal areas or river deltas for one or more season.

Impacts to subsistence fishing for Nuiqsut and Kaktovik caused by spill response and cleanup activities are expected to be minor to moderate depending on the extent and location of the spill. BOEM anticipates that spill response and cleanup activities would have negligible effects on Utqiagvik's subsistence fisheries. Negligible to moderate effects from spill response and cleanup are not expected to change the overall impact conclusions for a large spill.

Conclusions for Subsistence Fishing

For Nuiqsut, Kaktovik, and Utqiagvik, BOEM anticipates negligible impacts to subsistence fishing from routine construction, development, and production activities associated with the Proposed Action.

The winter construction and development activities planned for the Proposed Action in the Foggy Island Bay area are not anticipated to directly affect Arctic ciscoes overwintering in the Colville River Delta because there is no spatial overlap between this area and the Proposed Action Area. The proposed LDPI is not expected to block the Arctic cisco migration in coastal waters or interfere with summer feeding for Arctic ciscoes (Section 4.3.2). BOEM expects negligible impacts from the Proposed Action to Arctic ciscoes used for subsistence purposes.

BOEM anticipates negligible impacts on subsistence fishing from small spills associated with the Proposed Action for Nuiqsut, Kaktovik, and Utqiagvik. For subsistence fishers and community residents, stress and negative perceptions of contaminated subsistence foods such as Arctic cisco, Arctic char, and broad whitefish could be minor to major depending on the location of the small spill. If the small spill occurred where people fish, impacts of stress and perceived contamination could be major; if the spill is located away from where people fish, these types of effects could be minor. Actual contamination of subsistence fish resources resulting from small spills is not expected.

In the unlikely event that a large spill contacted the Colville River Delta during the Arctic cisco fishing season from September through December, impacts to subsistence fishing could be major for residents of Nuiqsut. If a large spill contacted the Colville River Delta in summer, effects to Nuiqsut's subsistence fishing are expected to be moderate. For Nuiqsut, BOEM anticipates a moderate to major impact to subsistence fishing from a large spill. BOEM anticipates moderate impacts to subsistence fishing for Kaktovik if a large spill occurs. BOEM anticipates negligible impacts to subsistence fishing from a large spill for residents of Utqiagvik.

Subsistence Waterfowl Hunting

Geese and eiders are an important food resource on the North Slope (Section 3.3.3; Table 4.3.3-1; Fuller and George, 1997; Huntington, 2009; SRB&A, 2010). Eiders specifically and waterfowl in general also hold substantial sociocultural importance for the Iñupiat people (Huntington, 2009).

Residents of Nuiqsut harvest geese April through June. The core goose hunting areas for Nuiqsut are located on Fish Creek, along the Colville River south of town, and to the north along Nigliq Channel. The core eider hunting area for Nuiqsut is an area up to ten miles offshore of the Colville River Delta and east to Thetis and Cross Islands May through September.

Kaktovik residents hunt geese close to shore and along inland rivers during May through September. Kaktovik's core hunting area for geese is located between Collinson Point to the west and Pokok Lagoon to the east, inland along major rivers, and across from Barter Island. Residents of Kaktovik hunt eiders on the coast in the same locations and at the same times as geese and as far west as the Sagavanirktok River.

Utqiagvik residents reported hunting geese as far east as Teshekpuk Lake, south of Wainwright, inland on the Meade and Chipp rivers, and substantial distances offshore west of Point Barrow. Residents of Utqiagvik generally hunt for eiders May through August. Eider hunting occurs offshore north and west of town and on the Inaru and Meade rivers.

Overlap with the Proposed Action. The proposed summer construction activities for LDPI slope protection and the proposed reclamation of the gravel mine overlap in time with waterfowl hunting activities for Nuiqsut, Kaktovik, and Utqiagvik.

There is potential spatial overlap between proposed LDPI slope protection activities proposed for May through August and eider hunting areas for Nuiqsut and eider and goose hunting areas for Kaktovik (Table 4.3.2-2; SRB&A, 2010). There also is potential for spatial overlap between Kaktovik's waterfowl hunting area and reclamation activities at the proposed gravel mine. Nuiqsut hunters sometimes go for eiders near Cross Island north of the Proposed Action Area and offshore of Foggy Island and Mikkelsen Bays. Kaktovik hunters pursue geese and eiders in the same places along the coast as far west as Prudhoe Bay, including the shorelines and nearshore waters of Foggy Island Bay. This is the far western extent of Kaktovik's waterfowl hunting area; their core waterfowl area is smaller, extending to the western edge of Camden Bay.

BOEM found no spatial overlap between the Proposed Action and subsistence goose hunting areas used by Nuiqsut hunters; BOEM anticipates negligible impacts to Nuiqsut's goose hunting season from routine construction, development, production, and decommissioning activities. BOEM found no spatial overlap between the Proposed Action and subsistence waterfowl hunting areas used by Utqiagvik hunters. For routine construction, development, production, and decommissioning activities, BOEM anticipates negligible impacts to subsistence waterfowl hunting for harvesters from Utqiagvik.

LDPI Slope Protection

LDPI slope protection activities are proposed as part of summer construction for the proposed LDPI to fortify the proposed LDPI's perimeter (Hilcorp, 2015). Slope protection activities are scheduled for May through August during Year 2 (Figure 2 -1; Hilcorp, 2015, p.16). Eider hunting season for Nuiqsut and goose and eider hunting seasons for Kaktovik primarily occur May through July (Table 4.3.3-1) and would be most at risk from potential impacts caused by slope protection work in summer. The waterfowl hunting seasons for Nuiqsut and Kaktovik could be affected by LDPI slope protection work. The potential effects could be disturbance of birds due to construction noises, disturbance or diversion of waterfowl and hunters caused by helicopter overflights, conflicts between waterfowl hunting boats and support vessels, and avoidance of the Proposed Action Area due to summer construction activities thereby potentially reducing goose and eider hunting opportunities for the Execute Year 3 open-water season. However, waterfowl would not become unavailable for one or more seasons, and hunters would have continued opportunities to go hunting for eiders and geese in areas closer to Nuiqsut and Kaktovik. Noises and disturbances from slope protection work and associated support vessel and aircraft traffic could result in short term and localized and thus minor impacts to subsistence waterfowl hunting for Nuiqsut and Kaktovik. This would especially be the case if hunters need to look for birds in the Proposed Action Area in May through August if eiders (and geese for Kaktovik) were not available closer to home.

Gravel Mine Reclamation

BOEM found potential for spatial overlap between reclamation activities at the gravel mine site and waterfowl hunting for Kaktovik. After completion of gravel mining, the mine site would be closed and rehabilitated. Rehabilitation would likely include conversion of the pit to aquatic habitat and re-contouring excavated overburden. The rehabilitation plan would likely include creation of shallow-water benches, and reseeding and/or replanting with locally adapted plants. Rehabilitation activities would likely occur during the summer (Hilcorp, 2015, Appendix A, p. 4-98).

The shoreline and coastal waters of Foggy Island Bay are part of Kaktovik's waterfowl hunting area. The proposed mine site is only one half mile inland from Foggy Island Bay, and reclamation would take five months in Execute Year 1. The Execute Year 1 waterfowl hunting seasons for Kaktovik could be affected by reclamation work at the proposed mine site. Potential effects could be disturbance of birds and hunters due to noises caused by reclamation activities, disturbance or diversion of waterfowl or hunters caused by helicopter overflights or vehicular travel on the tundra, and avoidance of the proposed mine site due to reclamation work thereby potentially reducing goose

and eider hunting opportunities for Kaktovik in Execute Year 1. However, waterfowl would not become unavailable for one or more seasons, and hunters would have continued opportunities to go hunting for eiders and geese in areas closer to Kaktovik. Noises and disturbances from reclamation work and associated support vehicle and aircraft traffic could result in short term and localized and thus minor impacts to subsistence waterfowl hunting for Kaktovik. This would especially be the case if hunters needed to look for birds in the Proposed Action Area May through September in Execute Year 1 if eiders and geese were not available closer to Kaktovik.

Oil Spills and Spill Response

Residents of Nuiqsut and Kaktovik have reported thousands of birds migrate into the Nuiqsut and Kaktovik areas during spring, and the entire Beaufort coast is important for a large variety of eiders, geese, and duck species for feeding and nesting in the warmer months (Section 3.2.3; SRB&A, 2011). Migratory waterfowl use the entire nearshore environment, including the coastline, barrier islands, and river deltas. The Proposed Action Area is located in the center of this important waterfowl habitat area. Small and large spills of crude and refined oil occurring May through September could adversely impact migratory waterfowl and subsistence bird hunting.

Small spills starting at the proposed LDPI and the far offshore portions of the pipeline are unlikely to affect individual birds, because small spills cover a small area and are less likely to persist in the environment (USDOJ, MMS, 2002). The USFWS has concluded that listed eiders would not be killed as a result of small spills from the Liberty project (USFWS, 2009, p. 28). Small spills starting from the nearshore portion of the pipeline could reach birds' shoreline habitat. Waterfowl are particularly vulnerable to oiling due to oil's effects on their feathers. If a small spill happened close to shore or at the pipeline crossing from seabed to land, a small number of birds and their nesting areas could potentially be oiled as a result of the Proposed Action. In the event that individual birds were contacted by a small spill, the impacts on birds are expected to be short term and localized and thus minor. A small number of individual birds could be oiled and become ill and/or die.

If small spills occurred during the main waterfowl hunting season, May through September, bird hunters from Nuiqsut and Kaktovik could experience negative perceptions of tainted waterfowl. Hunters would most likely be concerned that any birds traveling through the Proposed Action Area could be contaminated as a food source due to small spills. If small spills contacted the shoreline of barrier islands such as Cross Island, the shores of Foggy Island Bay, or the Sagavanirktok River Delta, during the waterfowl hunting season, subsistence bird hunting at these locations could be temporarily disrupted because hunters would be unable or unwilling to go there for fear of contaminated resources and oiled beaches. The impacts to subsistence waterfowl hunting would be short term and localized and thus minor and hunters would be able to pursue geese and eiders at different areas. The effects of perceptions of tainted birds as a food source would most likely be longer lasting and more widespread and thus moderate. However, small spills originating in the Proposed Action Area would most likely not reach important bird habitat due to relatively fast dispersion and evaporation unless a small spill originated at the shoreline from the pipeline.

BOEM anticipates that small spills would have a negligible impact on waterfowl hunting for Utqiagvik hunters because there is no spatial overlap between the Proposed Action Area and the waterfowl hunting area for Utqiagvik.

BOEM expects a large spill of crude or refined oil from the Proposed Action to have greater impacts to subsistence waterfowl hunting than small spills. Nuiqsut hunters primarily pursue geese in the western part of the Colville River Delta and along the eastern shores of Harrison Bay. This subsistence use area has a 6% chance of being contacted by a large spill originating from the proposed LDPI within 30 days after the event in July through September and a 3% chance of being oiled from a large spill starting at the pipeline. Thetis Island and up to 10 miles offshore of the Colville River Delta are used for eider hunting by Nuiqsut hunters. Within thirty days after a large

spill starting at the proposed LDPI, the Thetis Island area has a 10% chance of being oiled in summer and a 4% chance of being contacted by a large spill starting at the pipeline. The other eider hunting area for Nuiqsut is the Cross Island area offshore between Prudhoe and Mikkelsen Bays. Within thirty days after a large spill occurs, the Cross Island subsistence use area has a 26% chance of being contacted by a large spill from the proposed LDPI July through September; the chance of this important area being contacted by a large spill from the pipeline is 13%.

If any or all of these areas of coastal bird habitat were oiled by a large spill during the goose and eider seasons, Nuiqsut waterfowl hunters could experience severe and thus major impacts because this is their core waterfowl hunting area. Individual birds could be killed if contacted by oil. Waterfowl hunters from Nuiqsut would most likely stop goose hunting in the Colville River area and stop eider hunting near Thetis Island for one or more seasons due to oiled beaches and actual or perceived contamination of migratory birds. Geese may not be completely unavailable. Hunters would be able to pursue geese farther inland closer to town along the Colville River. They could look for eiders in the Cross Island area May through July, but this activity would most likely be limited to whaling crews August through September, plus Cross Island has a greater chance of being oiled July through September than Thetis Island and the Colville River Delta. Eider hunting by Nuiqsut hunters could be severely limited due to a large oil spill from the Proposed Action. Perceptions of tainting and stress and worry about contaminated birds would most likely be long lasting and severe due to a large oil spill for most of Nuiqsut's waterfowl hunting territory.

The far western portions of Kaktovik's waterfowl hunting area could be contacted by crude oil in the event of a large spill. The Sagavanirktok River Delta and Foggy Island Bay have a 68% chance of being oiled within 30 days after a large spill starting at the proposed LDPI during July through September; the chance of contact is 59% for a large spill originating at the pipeline. In the event of a large spill in the Proposed Action Area, Kaktovik hunters would most likely avoid the far western portions of their waterfowl hunting area between Prudhoe Bay and Flaxman Island, which would limit their waterfowl hunting opportunities to areas closer to town in the core hunting area for one or more seasons; the effects of which are expected to be minor to moderate depending on availability of geese and eider in the core area at the time of the spill. A large spill from the Proposed Action could cause long lasting and widespread and thus moderate impacts related to psychological stress and perceived and actual contamination of geese and eiders as a food source for one or more hunting seasons for residents of Kaktovik.

For Utqiagvik, BOEM expects short term and localized and thus minor impacts to subsistence goose and eider hunting as a result of a large spill of crude or refined oil. This is particularly the case for coastal areas east of Point Barrow such as southern Smith Bay if the shoreline or birds were oiled there. The Proposed Action Area is too great a distance from Utqiagvik's core offshore eider hunting area to be contacted by oil. Moreover, most goose hunting and some eider hunting is done inland on various rivers south of town that would not be contacted by a large oil spill (SRB&A, 2010). However, a large spill could cause long lasting and widespread and thus moderate impacts related to psychological stress and perceived contamination of geese and eiders as a food source for one or more hunting seasons for residents of Utqiagvik. Effects of perceived tainting could be less in Utqiagvik than for Nuiqsut and Kaktovik because waterfowl are observed to move from west to the east during spring migration past the Utqiagvik area (SRB&A, 2011), and oil from a spill at the Proposed Action Area would have to move from east to the west to have any potential effect at Utqiagvik.

Subsistence waterfowl hunting could be adversely affected by spill response and cleanup activities if those activities involved volunteer or paid employment of local subsistence hunters by diverting time, effort, and equipment away from bird hunting to oil spill response and cleanup for one or more seasons. However, earning cash from paid work in spill response and cleanup could allow some

subsistence hunters to purchase newer boats, motors, snowmachines, firearms, ammunition, and fuel needed to effectively pursue waterfowl.

Depending on the size of the spill and whether or not it contacted onshore and offshore important habitat for geese and eiders and other subsistence resources, response and cleanup duration and impacts could be short-term and localized or long lasting and widespread.

Mechanical methods used to recover spilled oil offshore are not expected adversely affect subsistence waterfowl hunting. Mechanical recovery and physical cleanup methods used on the shorelines and in nearshore waters in summer could disrupt waterfowl and subsistence hunting by boats for Nuiqsut and Kaktovik. The use of chemical dispersants and in-situ burning would most likely result in perceptions of environmental contamination and tainting of waterfowl and their critical habitat areas that could last for one harvest season or longer. Perceptions of contamination and actual contamination of birds used for food due to spill response and cleanup could result in cessation of subsistence waterfowl hunting in oiled coastal areas such as shorelines of barrier islands or river deltas for one or more seasons.

Impacts to subsistence waterfowl hunting for Nuiqsut and Kaktovik caused by spill response and cleanup activities are expected to be minor to moderate depending on the extent and location of the spill. BOEM anticipates that spill response and cleanup activities would have negligible effects on Utqiagvik's waterfowl hunting activities. Negligible to moderate effects from spill response and cleanup are not expected to change the overall impact conclusions for a large spill.

Conclusions for Waterfowl Hunting

BOEM anticipates negligible impacts to Nuiqsut's goose hunting season from routine construction, development, production, and decommissioning activities and negligible impacts to subsistence waterfowl hunting for harvesters from Utqiagvik.

Noises and disturbances from LDPI slope protection work and associated support vessel and aircraft traffic scheduled for May through August could result in minor impacts to subsistence waterfowl hunting for Nuiqsut and Kaktovik.

Noises and disturbances from reclamation work at the proposed gravel mine and associated support vehicle and aircraft traffic could result in minor impacts to subsistence waterfowl hunting for Kaktovik. BOEM anticipates that minor impacts to waterfowl hunting from LDPI slope protection and mine reclamation activities could be reduced to negligible or completely eliminated. This would require communication and monitoring on the part of both industry and subsistence harvesters (Appendix C). Industry should work with waterfowl hunters from Nuiqsut and Kaktovik to establish a communication center and hire local subsistence advisors. Other specific measures include 1) plan ahead to time and locate construction and reclamation activities to minimize exposure of waterfowl and hunters to noise and vessel and vehicle traffic, learn from local hunters areas and times that are most sensitive for waterfowl and subsistence hunting activities (SRB&A, 2009); 2) set minimum altitudes for industrial helicopter overflights, for example 1500 feet; and 3) put in place a real-time monitoring and response communication system so harvesters out on the land and water can speak directly with dispatchers, alert harvesters to planned construction activities, and enable harvesters and industrial pilots to speak directly to learn and exchange ideas to minimize impacts from helicopter overflights.

For small spills of crude or refined oil, BOEM anticipates minor to moderate impacts to subsistence waterfowl hunting for Nuiqsut and Kaktovik. BOEM anticipates that small spills would have a negligible impact on waterfowl hunting for Utqiagvik hunters because there is no spatial overlap between the Proposed Action Area and the waterfowl hunting area for Utqiagvik.

For a large oil spill, BOEM expects major impacts to subsistence waterfowl hunting for Nuiqsut and minor to moderate impacts to subsistence waterfowl hunting for Kaktovik and Utqiagvik.

4.4.3.2. Effects of Alternative 2 on Subsistence Harvest Patterns

Under Alternative 2, potential impacts would not occur to subsistence activities and harvest patterns from disruptions to hunting and fishing due to noise, physical presence, diversion of animal and fish migrations, and actual or perceived contamination associated with the Proposed Action. There would be no impacts on subsistence harvest patterns for Nuiqsut, Kaktovik, and Utqiagvik.

4.4.3.3. Effects of Alternative 3 on Subsistence Harvest Patterns

In Alternative 3, the proposed LDPI would be relocated to one of two locations (Section 2.2.3). Alternative 3A would relocate the proposed LDPI one mile to the east into slightly deeper water, and Alternative 3B would relocate the proposed LDPI 1.5 miles to the southwest into slightly shallower water and closer to the shoreline of Foggy Island Bay.

For both Alternative 3A and 3B, the proposed LDPI would remain in the southern portion of Nuiqsut's whaling area. Moving the proposed LDPI closer to shore into shallower water would most likely reduce the likelihood of the proposed LDPI interfering with movement patterns of bowhead whales inside the barrier islands and Cross Island whaling activities, but the decreases in this case would be negligible since most whaling activities and whale sightings have been farther to the north and east of the proposed LDPI site. Moving the proposed LDPI farther to the east into deeper water could increase the likelihood of interference with whaling practices and bowhead movement patterns, but these increases in likelihood would be negligible for the same reasons.

Alternatives 3A and 3B would not change the potential likelihood or severity of whaler avoidance of the Proposed Action Area or negative perceptions of tainted subsistence resources and general avoidance of industrial developments while subsistence hunting and fishing.

Both options under Alternative 3 would increase drilling time, size and power of the drill rig, fuel consumption, risk, and technical difficulty. These changes would most likely increase the amount of overall noise produced at the proposed LDPI site. However, the increased drilling noise under Alternatives 3A and 3B is not expected to change the likelihood or severity of potential impacts to subsistence harvest patterns.

Alternative 3A would increase construction time and materials which could extend potential impacts from LDPI slope protection activities into late summer and early fall. This change could increase potential impacts to subsistence harvest patterns especially if construction activities were extended into the fall whaling season for Nuiqsut and/or into a second summer construction season and hence a second whaling season. Under 3A, effects to whaling for Nuiqsut from summer construction activities at the proposed LDPI would remain major but could be prolonged into a second whaling season. This increase in summer construction time could also increase impacts on subsistence seal hunting from minor to moderate for Nuiqsut and Kaktovik.

Alternative 3B would decrease construction time and materials, which could reduce potential impacts to subsistence harvest patterns. Under 3B, effects to whaling for Nuiqsut from summer construction activities at the proposed LDPI could be reduced. If Alternative 3B allowed summer construction at the proposed LDPI to cease by August 25, impacts to whaling for Nuiqsut from LDPI slope protection work could be reduced from major to moderate. If 3B allowed summer construction at the proposed LDPI site to cease by July 25, impacts to whaling for Nuiqsut from LDPI slope protection work could be reduced from major to negligible. This change could also reduce potential impacts to subsistence seal hunting from minor to negligible for Nuiqsut and Kaktovik hunters.

Alternative 3B would move the proposed LDPI and operations into waters managed by the SOA. If the proposed LDPI were moved 1.5 miles to the south into state waters, the property taxes would

increase (Section 2.2.4). Some of the increased revenue to the state from Alternative 3B could benefit the NSB. Added revenue income to the NSB could benefit communities and individual subsistence harvesters. Increased revenue could cause short term minor and beneficial impacts to the sociocultural systems in the NSB (Section 4.4.1.3).

Alternative 3A would most likely increase the length of the annual ice road from the SDI to the proposed LDPI and summer travel between SDI and the proposed LDPI. A slightly longer ice road on sea ice is not expected to change the likelihood or severity of impacts to subsistence harvest patterns. More travel time during the summer via vessels and helicopters could increase impacts to subsistence harvest patterns; in particular, increased helicopter over flights could add to the severity of impacts on summer caribou hunting for Kaktovik. However, BOEM does not expect this change to increase the likelihood of impacts on subsistence caribou hunting in summer for Kaktovik because the Proposed Action Area is located in the far western portion of Kaktovik's historic caribou hunting territory; during the 25-year life of the Proposed Action, hunters from Kaktovik would most likely only rarely use the coastal areas of western Foggy Island Bay for caribou harvest. Overall, impacts to summer caribou hunting would not differ substantially from impacts associated with the Proposed Action.

Conclusion for Alternative 3A

Most impacts of Alternative 3A on subsistence activities and harvest patterns would be the same as those for the Proposed Action (Section 4.3.3.1) with the exception of potential effects of summer construction on whaling and seal hunting. Potential effects on whaling for Nuiqsut from summer construction activities at the proposed LDPI would remain major but could be prolonged into a second whaling season, which could increase the duration and likelihood of impacts to subsistence whaling. Impacts to subsistence seal hunting from LDPI slope protection work could increase from minor to moderate, especially if seal hunters from Nuiqsut and Kaktovik could not find seals closer to home and needed to look for seals closer to the proposed LDPI. Overall, BOEM expects Alternative 3A to have moderate to major adverse effects to subsistence whale and seal hunting for Nuiqsut and Kaktovik.

Conclusion for Alternative 3B

Most impacts of Alternative 3B on subsistence activities and harvest patterns would be the same as those for the Proposed Action (Section 4.4.3.1) with the exception of potential effects of summer construction on whaling and seal hunting. If Alternative 3B allowed summer construction at the proposed LDPI to cease by August 25, impacts to whaling for Nuiqsut from LDPI slope protection work could be reduced. If 3B allowed summer construction at the proposed LDPI site to cease by July 25, impacts to whaling for Nuiqsut from LDPI slope protection activities could be further reduced. This change could also reduce potential impacts to subsistence seal hunting for Nuiqsut and Kaktovik hunters. BOEM anticipates negligible to moderate adverse effects to subsistence whale and seal hunting for Nuiqsut and Kaktovik from Alternative 3B. If increased tax revenue was provided to the NSB as a result of moving the proposed LDPI into state waters, subsistence harvesters in Nuiqsut, Kaktovik, and Utqiagvik could benefit through minor beneficial impacts to the sociocultural system (Sections 4.4.1.1 and 4.4.1.3).

4.4.3.4. Effects of Alternative 4 on Subsistence Harvest Patterns

Under Alternative 4, oil and gas processing would not occur on the proposed LDPI and would be relocated to one of two alternate facilities (Section 2.2.5).

Both Alternative 4A and 4B would reduce the construction time for the offshore proposed LDPI, perhaps by as much as 20 days, which could reduce potential effects to subsistence harvest patterns. Decreasing summer construction activities at the proposed LDPI site related to LDPI slope protection could reduce impacts to whaling for Nuiqsut from major to moderate or negligible depending on

when summer construction would cease. This change could also reduce potential impacts to subsistence seal hunting from minor to negligible for Nuiqsut and Kaktovik hunters.

For both Alternative 4A and 4B, the proposed LDPI would remain in the southern portion of Nuiqsut's whaling area. Alternative 4 would not change the potential likelihood or severity of whaler avoidance of the Proposed Action Area or negative perceptions of tainted subsistence resources and general avoidance of industrial developments while subsistence hunting and fishing.

Both Alternative 4A and 4B would increase construction time for the offshore pipeline in winter months. Alternative 4B would increase onshore construction activities in winter at the Badami pipeline tie-in point and would most likely increase the likelihood and severity of potential impacts to caribou if the processing facility was built and operated there. However, BOEM does not anticipate that these longer construction times in winter for the pipeline or the new processing facility would increase the likelihood or severity of potential impacts on subsistence activities or harvest patterns, including caribou hunting by subsistence harvesters from Kaktovik.

Over the 25-year life of proposed operations, Alternatives 4A and 4B would most likely reduce the overall noise produced at the proposed LDPI because all noise directly associated with processing would be substantially farther from the proposed LDPI site. All power for both the onshore and offshore facilities would be generated onshore, further reducing noises offshore at the proposed LDPI site. The added pumps at the proposed LDPI location would produce some noise during seawater injection and movement of unprocessed product to the onshore processing facility. Overall, BOEM does not anticipate any added advantage or reduced impact to marine mammals such as bowhead whales from this reduction in offshore noise. However, substantial reduction of noise at the offshore proposed LDPI site would most likely reduce impacts to Cross Island whalers and other residents of Nuiqsut associated with their knowledge and experience of how noise decreases whaling success. Moving oil and gas processing to Endicott or onshore near Badami would most likely decrease negative perceptions of noise in the marine environment.

Conclusions for Alternatives 4A and 4B

Most impacts of Alternative 4A on subsistence activities and harvest patterns would be the same as those for the Proposed Action (Section 4.4.3.1) with the exception of potential effects of summer construction on whaling and seal hunting. Decreasing the time needed for summer construction activities for LDPI slope protection work could reduce impacts to whaling from summer construction for Nuiqsut (Section 4.4.3.1). This change could also reduce potential impacts to subsistence seal hunting for Nuiqsut and Kaktovik hunters. Moreover, moving oil and gas processing to Endicott or onshore near Badami would most likely decrease negative perceptions of noise in the marine environment that Cross Island whalers know can cause deflection of the whale migration farther offshore, increased difficulty in hunting, skittishness in whale behavior, and lower success in whaling. Overall, BOEM expects negligible to moderate adverse effects to subsistence whale and seal hunting for Nuiqsut and Kaktovik from Alternative 4.

4.4.3.5. Effects of Alternative 5 on Subsistence Harvest Patterns

Alternative 5 would relocate the gravel mine from the proposed mine site west of the Kadleroshilik River to a new or existing gravel mine site (Section 2.2.6). There are three alternate mine sites, including two new sites, Alternatives 5A and 5B, east of the Kadleroshilik River and Alternative 5C, the existing Duck Island mine site on Endicott Road in the Sagavanirktok River Delta.

BOEM anticipates that impacts from Alternatives 5A and 5B on subsistence activities and harvest patterns would be essentially the same as impacts described for the Proposed Action (Section 4.4.3.1).

Alternative 5C would most likely increase construction time for the proposed LDPI, possibly into a second season. This could increase impacts and disturbances to small numbers of caribou

overwintering on the coastal plain. However, BOEM does not anticipate that this longer construction time in winter for hauling gravel and building the proposed LDPI would increase the likelihood or severity of potential impacts on subsistence activities or harvest patterns, including caribou hunting by subsistence harvesters from Kaktovik.

If Alternative 5C extended summer construction activities at the proposed LDPI site related to LDPI slope protection, impacts to subsistence whaling for Nuiqsut and seal hunting for Nuiqsut and Kaktovik could be increased; impacts to Nuiqsut's whaling season would remain major but could be prolonged into a second season and impacts to subsistence seal hunting could increase from minor to moderate, especially if seal hunters from Nuiqsut and Kaktovik could not find seals closer to their villages and needed to hunt in the Foggy Island Bay area during the two summer construction seasons needed for Alternative 5C. The likelihood that subsistence harvesters from Nuiqsut and Kaktovik would need to use the Foggy Island Bay area for seals during this timeframe is low.

Conclusion for Alternatives 5A and 5B

Impacts from Alternatives 5A and 5B on subsistence activities and harvest patterns would be essentially the same as impacts described for the Proposed Action (Section 4.3.3.1).

Conclusion for Alternative 5C

Most impacts of Alternative 5C on subsistence activities and harvest patterns would be the same as those for the Proposed Action (Section 4.4.3.1) with the exception of potential effects of summer construction activities on whaling and seal hunting. Potential effects on whaling for Nuiqsut from summer construction activities at the LDPI would remain major but could be prolonged into a second whaling season. Impacts to subsistence seal hunting from LDPI slope protection work could increase from minor to moderate, especially if seal hunters from Nuiqsut and Kaktovik could not find seals closer to home. Overall, BOEM anticipates moderate to major adverse effects to subsistence whale and seal hunting activities for Nuiqsut and Kaktovik from Alternative 5C.

4.4.4. Community Health

Overview

The main community health conclusions of the Arctic Monitoring and Assessment Program oil and gas assessment (AMAP, 2009, p. 16-17) indicate that there are unlikely to be any major impacts from contaminants exposure from exploration and extraction activities on human populations in the Arctic unless there are major oil spills.

Social impacts from arctic oil and gas development are foreseeable, however. Social impacts are consequences of private or public actions or programs that result in changes in people's ways of life, cultures, communities, economies, political systems, environments, health and wellbeing, or aspirations for the future (CGG, 2006). Social impacts of oil and gas activities associated with increased disposable income, an influx of workers from outside the arctic communities, more community revenue, and changes in social and cultural integrity may occur and could affect community health outcomes (AMAP, 2009, p. 17). Social effects are expected to be both positive (e.g., better health and educational services) and negative (e.g., dietary, social, and cultural disruptions).

To analyze the effects of the Proposed Action and alternatives on community health, BOEM used a subsistence harvest lens and applied a broad definition of community health (Section 3.3.4). The analysis is focused on potential disruptions to sociocultural systems, subsistence activities, subsistence harvest patterns, and other determinants of community health. This analysis primarily focusses on Nuiqsut because it is located closest to the Proposed Action Area (Figure 3.3.3-1; Appendix D) and has the greatest potential to experience changes to subsistence harvest patterns (Table 4.4.1-1; HHIC, 2015).

Community Health and Subsistence

In the NSB, healthy people and community well-being are inseparable from a subsistence way of life and depend on having intact and functional sociocultural systems (Section 3.3.4.4). Participation in traditional subsistence activities provides nutritious foods, physical activity, and social interactions across generations and is a vital part of maintaining cultural integrity and individual and community health and well-being (Gadamas, 2013; Haley and Magdanz, 2008; McAninch, 2012, p. 90; Smith et al., 2009; USARC, 2015). Availability of and access to traditional foods and other local subsistence resources are critical determinants of physical and social health and cultural well-being in Nuiqsut and other communities in the NSB.

Perceived and actual threats to subsistence activities and harvest patterns are a primary source of ongoing concern and stress in North Slope communities (Kruse, 2010). If subsistence harvest patterns and sociocultural systems are disrupted by the Proposed Action, local diets and community organization could be compromised, and adverse impacts to community health could result (USDOJ, BOEM, 2015, p. 421). Harvest loss, if sustained, could result in disruptions to food sharing patterns, which could create cultural stress and diminish general health, nutritional health, and well-being for some rural residents of the NSB; in turn, these effects could adversely impact rates of social problems, mental health disorders, and suicide (McGrath-Hanna et al., 2003). Ultimately, sustained loss of subsistence harvests could erode or damage cultural values and create stress on local institutions such as local whalers' associations and healthcare providers.

Community Health and Climate Change

As described in Chapter 3, global climate change could alter current conditions in the Proposed Action Area during the 25-year life of the Proposed Action. Further disruptions to subsistence harvest patterns from global environmental and climatic changes could foreseeably have adverse effects on community health in the NSB (ANTHC, 2014). Beneficial effects of climate change may occur as well. Effects of global climate change to community health are anticipated to continue well into the future beyond the 25-year life of the Proposed Action. Adverse effects would most likely be related to losses of opportunities to practice subsistence hunting, fishing, and sharing. For example, factors associated with climate change may alter communities' abilities to harvest resources due to less reliable ice conditions and more severe weather events. Beneficial effects would most likely be related to increased or improved access to current or new subsistence resources such as improved ability to travel and navigate rivers in search of terrestrial mammals and freshwater fishes (Huntington, Quakenbush, and Nelson, 2016). The capacity of vulnerable individuals and communities to adapt could have substantial bearing on community health and wellbeing (Curtis et al., 2005; Gadamas, 2013). However, during the next 25 years, BOEM does not expect the effects of the Proposed Action on subsistence harvest patterns to change from those described in Chapter 4 due to potential changes related to global climate change. Overall, BOEM does not anticipate, in this relatively short timeframe, that climate change would alter the impacts of the Proposed Action to community health as described in Chapter 4. Climate change is further discussed in Chapter 5 in the context of cumulative effects on community health and sociocultural systems.

4.4.4.1. Effects of the Proposed Action on Community Health

Potential health effects of oil and gas development are a matter of growing concern for the Iñupiat people of Alaska's North Slope (Gore, 2009, p. 35; HHIC, 2015; BLM, 2014, p. 462; Wernham, 2007, p. 501). During public scoping for this Draft EIS, BOEM heard examples of community health concerns related to the Proposed Action, including:

- Effects of a large offshore oil spill on biological resources, human health, and cultural well-being of communities that depend on subsistence resources, especially migratory marine mammals and ocean fishes; for more discussion see EDAW AECOM (2008).

- Concerns over food security, food purity, environmental contaminants, and related community health outcomes.
- Concern that conditions related to encroaching industrial developments pose unreasonable risks to community health; for example, cumulative effects of air pollution from gas well flares, small fuel/oil spills, and industrial accidents may result in contamination of wildlife and other food and water resources and health risks to people such as increased respiratory problems and psychological stresses; for more discussion see Ahtuanguaruak (2015), BLM (2014, Section 4.4.6), and SRB&A (2009).

The Proposed Action could impact community health by the following means:

- Disruptions to subsistence activities and harvest patterns, which in turn can adversely affect food security, nutritional status, and cultural well-being
- Emissions of air pollutants
- Decreased water quality
- Increases in employment, income, and economic revenue could impact health in both positive and negative ways.
- Oil spills and spill response and cleanup activities

Subsistence, Food Security, and Nutrition

More than one in three household heads in the NSB reported difficulty in getting the food needed to eat healthy nutritious meals, and more than one in four Iñupiat household heads reported that, at times last year, household members did not have enough to eat (McAninch, 2012, p. 6). Kaktovik reported 40% of households to be food insecure (Kofinas et al., 2016, p. 214).

Residents of the NSB derive substantial health benefits from harvesting and eating traditional foods (Section 3.3.4.3; Bersamin et al., 2007; McAninch, 2012; Reynolds et al., 2006; Smith et al., 2009). Adverse effects on subsistence harvests discussed in Section 4.3.1 could result in increased food insecurity and nutritional deficiencies (DHSS, 2011, p. 61), which could increase the risk of chronic illnesses related to diet and nutrition such as diabetes, high blood pressure, and cardiovascular diseases. These chronic illnesses are referred to as metabolic disorders, and the risk of developing these health problems increases with decreasing intake of subsistence foods (Curtis et al., 2005; McAninch, 2012; McGrath-Hanna et al., 2003; Reynolds et al., 2006; USDO, MMS, 2007, p. IV-240; Wernham, 2007). The combination of diet (e.g., lean protein sources, low sugar levels, healthy fatty acids) and active lifestyle (i.e., physical exercise) associated with subsistence hunting, fishing, and gathering is the most important protective factor against developing metabolic disorders. Adverse metabolic health effects could accrue as a result of the Proposed Action if subsistence resources became unavailable or undesirable for use as foods or subsistence areas were avoided.

As analyzed in Section 4.4.1.1, if adverse moderate to major impacts to subsistence harvest patterns resulted from the Proposed Action or alternatives, the highest potential for changes to community health related to food insecurity and nutrition would most likely be in the community of Nuiqsut. The Proposed Action could adversely affect community health if it adversely affects the health and viability of populations of species important for subsistence harvest or disrupts availability of and/or access to important subsistence resources such as bowhead whales, seals, and waterfowl (Kuukpiik Corporation, 2015).

Potential moderate to major disruptions to the bowhead whale migration route and bowhead whaling conducted near Cross Island by Iñupiaq whalers from Nuiqsut (Table 4.4.3-1) could adversely impact community health. In turn, impacts from loss of subsistence bowhead harvests on community health could be long lasting and widespread and thus moderate. If adverse impacts to subsistence harvest were minor, contemporary harvest patterns and sharing networks would be able to compensate, and

there would likely be little to no adverse impacts to community health related to loss of subsistence harvest opportunities (Appendix D).

Cultural Well-Being

Sociocultural values can have a positive influence on community health. A loss of sociocultural values can occur with a loss of eating and sharing traditional subsistence foods. Eating and sharing traditional subsistence foods has been reported to be a substantial contributor to cultural identity, tradition, and social cohesion in Inuit communities; to eat and enjoy traditional food is perceived as a marker of identity similar to speaking the Inuit language (Curtis et al., 2005). Social cohesion, interconnectedness, and stability in cultural and social institutions make up the core of community health and well-being in Inuit communities, and research has shown connections between cultural continuity and mental health in the Arctic (Curtis et al., 2005).

The process of cultural change, especially if dramatic and rapid, can cause stressors such as loss of traditional food resources and practices, unemployment, loss of cultural practices, psychological stress, and out migration. These experiences may overwhelm individuals in a community with feelings of loss of control, leading to depression, anxiety, substance abuse, and suicide (Curtis, et al., 2005). While social problems may be related to long-term economic and structural changes in Inupiat culture, historic patterns of social problems (e.g., traumatic death rates associated with alcohol abuse) on the North Slope during periods of oil development such as 1970-1977 do not suggest that oil and gas development itself caused or accelerated social disorganization on the North Slope (Kruse et al., 1982, p 103).

The Proposed Action is not expected to dramatically or rapidly change the Inupiaq culture of the North Slope or substantially reduce cultural well-being in Nuiqsut, Kaktovik, or Utqiagvik. Some of these adverse impacts to cultural well-being and community health could occur, however, if the Proposed Action caused a substantial loss of subsistence harvests or large influxes of outside oil and gas workers into communities (DHSS, 2011; USDO, MMS, 2007c, p. IV-241). Potential moderate to major disruptions to the bowhead whale migration route and bowhead whaling conducted near Cross Island by Inupiaq whalers from Nuiqsut (Table 4.4.1-1) could adversely impact cultural well-being and community health. Impacts from loss of subsistence bowhead harvests on community health could be long lasting and widespread and thus moderate.

Air Pollutant Emissions

Community members from Nuiqsut have expressed concerns about adverse health impacts due to air pollution emitted from oil and gas developments near their community (Ahtuanguak, 2015; SRB&A, 2009; BLM, 2014, p. 462-463).

Airborne emissions from the Proposed Action include the USEPA's criteria pollutants (Section 4.2.2., Air Quality). The criteria pollutants have been associated with a variety of adverse health effects (BLM, 2014, p. 463; USEPA, 2017; USDO, MMS, 2007, p. IV-242; Wernham, 2007). The most common and major health effects include causing and exacerbating respiratory illnesses such as asthma, cardiac arrhythmias, coronary artery disease, and excess mortality among vulnerable groups of people. Particulate matter is associated with increased respiratory symptoms, including irritation of the airways, coughing or difficulty breathing, chronic bronchitis, and decreased lung function (EPA, 2016).

Air pollution would result from emissions of criteria pollutants from diesel engines associated with routine vessel traffic, construction activities, and operation of equipment in support of the Proposed Action. Support vessels, helicopters, and drilling rigs would emit air pollutants, mainly from combustion of diesel fuel. Well venting and flaring during development would result in combustion products and particulate matter. Construction vessels, trucks, cranes, and other hauling and lifting equipment used to construct ice roads, the proposed LDPI, and the pipeline would emit air pollutants.

Emissions of these criteria pollutants from the Proposed Action would increase concentrations to some extent in various locations within the NSB. However, emissions from vessels, helicopters, and onshore vehicles associated with the Proposed Action are expected to have a negligible impact on the air quality in Nuiqsut and other onshore locations (Section 4.2.2.1). Measurable impacts from stationary sources at the nearest air quality monitoring stations from routine activities are expected to be minor; impacts of accidental oil spills on air quality would most likely be minor; and the overall air quality analysis indicates negligible to minor impacts from the Proposed Action (Section 4.2.2.1).

Accordingly, BOEM anticipates impacts to community health due to air pollution emissions to be short-term and localized and thus minor. Emissions of air pollutants from the Proposed Action are not expected to result in losses of subsistence harvest opportunities or disruptions to sociocultural systems.

Water Quality

A reduction in water quality as a result of the Proposed Action could adversely impact community health if discharges or oils spills occur in waters used for subsistence hunting and fishing activities.

Overall, it is expected that the Proposed Action would have minor to moderate impacts on marine water quality because there is no planned discharge of drilling wastes into the marine environment (Section 4.2.2, Water Quality; Hilcorp, 2015, Appendix A). Hilcorp (2015, Appendix A) anticipates negligible to minor impacts to freshwater quality. Increased turbidity caused during construction of the LDPI and offshore pipeline would most likely have the greatest effect on water quality; however, these increases would be short term, primarily occurring during the first winter and following summer construction seasons (Hilcorp, 2015, Appendix A).

NPDES-permitted discharges are anticipated to have negligible to no impacts on community health.

BOEM anticipates little to no and thus negligible impact on community health related to water quality. The Proposed Action is not expected to impact drinking water supplies in the NSB. BOEM expects no loss of subsistence harvest opportunities or disruptions to sociocultural systems due to minor to moderate increases in turbidity.

Employment, Income, and Economic Growth

Potential effects to the economy could occur if the Proposed Action alters employment or income characteristics of the area, increases tax revenue, changes the population demographics of the area, changes the workforce, or otherwise affects the employment and economic opportunities for residents of Nuiqsut or other communities on the North Slope (Section 4.3.2).

Increased oil and gas development and production from the Proposed Action could contribute benefits to the local economy and could affect community health via greater personal income and improved local infrastructure, educational systems, law enforcement, and healthcare services (Kruse et al., 1982; USDOJ, BOEM, 2015, Section 4.3.13.1.1). More disposable income could allow residents to purchase better gear and hunting and fishing equipment and increase their hunting effectiveness (Kruse et al., 1982). On the other hand, more time spent working for wages could take time away from subsistence activities. Better infrastructure and more jobs could lead to increased population.

Employment and economic development are generally viewed as positive in terms of effects to sociocultural problems and social pathologies (USDOJ, MMS, 2007c, p. IV-241). To the extent that the Proposed Action results in increased regional or local village income, this could result in beneficial effects to community health. Increased income for individuals or families could improve health in Nuiqsut through increased standard of living, reductions in stress, and increased opportunities for personal growth and social relationships (BLM, 2014, p. 462). Income and employment also could strengthen community and cultural ties and improve diet and nutrition through better funded subsistence activities and more affordable and healthier store-bought foods.

However, if local economic changes result in actual or perceived inequalities in a community, tensions and social stresses could develop (USDOJ, MMS, 2007c, p. IV-241). During public scoping in Nuiqsut, BOEM learned of increased infighting over economic benefits of oil and gas development (Section 3.3.5.4). Income disparity could increase if some residents benefited or were more adversely impacted than others from these economic changes; disparities in occupational status and income have been linked to adverse impacts on general health, psychological health, and well-being (Wilkinson and Marmot, 2003). In the past, the NSB has done a reasonably good job of distributing high paying jobs funded through oil tax revenues to a large portion of the population with the effect of preventing large disparities in income (Kruse et al., 1982). Other potential adverse impacts of economic growth are related to increased prevalence of social problems such as substance abuse, domestic violence, and accidental and intentional injuries (BLM, 2014, Section 4.4.6) and negative perceptions about the availability of fish and game and erosion of Iñupiaq cultural values and practices (Kruse, et al., 1982).

Revenue to the NSB and village corporations could allow for continued and improved funding of existing healthcare and social programs in communities such as Nuiqsut; new jobs in the oil and gas sector could be created, but it is anticipated that too few new jobs in this sector would directly go to Iñupiaq workers to create any local health benefits (BLM, 2014, p. 462). BOEM expects negligible to minor beneficial effects from employment and earnings and moderate beneficial effects from tax revenue generated by the Proposed Action (Section 4.4.2). Short-term and localized increases in local employment could occur, primarily in Nuiqsut. Subsequent increases in population from the Proposed Action are anticipated to be negligible, and healthcare delivery systems are not expected to be adversely impacted.

During the 25-year life of the Proposed Action, overall beneficial impacts to community health in the NSB from employment, income, and revenue would most likely be negligible to moderate, depending on how many local jobs are created in the NSB government. Adverse impacts to community health related to income and economic growth would most likely be short-term and localized and thus minor.

Oil Spills and Spill Response

Small spills have the potential to adversely impact sociocultural systems, and thus community health, by disrupting subsistence harvest patterns (Section 4.4.1). Effects to community health from small accidental spills occurring during routine construction, development, production, and decommissioning operations are expected to be short-term and localized and thus minor.

Although unlikely, BOEM assumes that a large spill could occur over the 25-year life of the Proposed Action. A large spill during development and production activities could adversely impact community health depending on the type and amount of oil spilled, location, and season. In the event of a large oil spill, subsistence resources and harvest patterns would most likely be affected due to contact with crude oil or refined products and could result in long lasting and widespread to severe impacts to community health for Nuiqsut. These impacts to community health would primarily be realized through major disruptions to subsistence practices and loss of harvest opportunities (also Section 4.4.1.1 Loss of Subsistence Harvests). Moderate to major impacts to community health would include compromised nutrition and general decreases in community and cultural well-being due to a lack of traditional foods and inability to engage in traditional practices such as sharing food with elders.

A large oil spill could affect NSB communities due to toxic contamination or perceived contamination of air, water, soils, and subsistence harvest resources such as fish or marine mammals. In turn, perceived and/or actual contamination could increase community stressors such as avoidance of subsistence harvests and decreased sharing and consumption of traditional foods. Moreover, impacts of a large oil spill to subsistence harvest of bowhead whales could be major for Nuiqsut and moderate to major for Kaktovik and Utqiagvik (Table 4.4.1-1; Section 4.4.3). Potential impacts to

bowhead whaling from a large spill of crude or refined oil could translate to severe impacts to community health in the NSB, especially for Nuiqsut where major impacts to whaling could occur in the event of a large spill (Section 4.4.3).

Spill response and cleanup workers from both inside and outside communities could experience potential health hazards from toxic oil byproducts, dispersants, detergents, and degreasers. Drowning, cold exposure, and falls also pose hazards to oil spill response workers. Changes in air quality could occur as a result of spills of crude or refined oil. Adverse health consequences of a large oil spill to community members could be experienced from exposure to vapors, particulate matter from controlled burns of spilled oil, VOC, PAHs, and heavy metals. However, impacts to air quality from accidental small oil spills would most likely be short term and localized and thus minor due to the limited geographical and temporal extent of the spill impact area (Section 4.1.2.1). Impacts on air quality due to a large spill also are likely to be minor; air quality impacts immediately following a large spill would most likely be short-term (Section 4.1.2.1), and BOEM does not expect adverse impacts to community health to occur from air pollutants released during a large oil spill.

Impacts to community members could occur when they work on spill response and cleanup alongside outside workers who may be unfamiliar with Iñupiaq culture, and who may bring illnesses and social conflicts to villages. Large oil spills can have long lasting and widespread adverse but reversible physical and mental impacts for community members living in the affected area (Eykelbosh, 2014). Researchers working on health impacts in Alaskan communities impacted by the *Exxon Valdez* oil spill in 1989 found community members showed changes in indicators of post-traumatic stress, including greater degrees of stress in the forms of recurrent, unprovoked, negative thoughts about the spill and avoidance behaviors such as suppression of thoughts and behaviors related to the spill (Picou et al., 1992). Researchers found these intrusive stresses declined somewhat over time but remained elevated compared to the control community 18 months after the spill; avoidance behaviors remained constant over time, indicating persistent, long-term psychological harm to individuals (Eykelbosh, 2014, p. 19). The trauma associated with oil spills, whether due to income loss, disruption of culturally important activities, or the stress of long-term uncertainty, can lead to depression, generalized anxiety disorder, and post-traumatic stress (Eykelbosh, 2014, p. 34).

Spill response and cleanup activities could include mechanical recovery methods, use of dispersants, and in-situ burning of spilled oil. Increased aircraft and vessel traffic, and corresponding increases in vessel discharges and noise, would also be associated with spill response and cleanup operations. Depending on the size of the spill and whether or not it contacted onshore resources response and cleanup time and extent of cleanup activities could be short-term and localized or long lasting and widespread.

If spill response and clean-up operations included sections of beach and shorelines of barrier islands, access to areas used for subsistence fishing, waterfowl hunting, caribou hunting, and butchering of whales could be disrupted by spill response and cleanup activities or restricted by regulators due to conservation and species recovery issues. Disruptions to subsistence harvest practices due to spill response and cleanup could be long lasting and widespread for Nuiqsut. Loss of subsistence opportunities from response and cleanup could cause moderate impacts to community health.

Offshore mechanical recovery methods are not expected to impact community health because this method of spill cleanup is not expected to affect subsistence harvest patterns, social organization, local institutions, cultural well-being, or cultural values. The use of chemical dispersants and in-situ burning would most likely result in perceptions of environmental contamination and tainting of subsistence resources that could last for one or more seasons. Perceptions of contamination and actual contamination of marine resources from cleanup activities could result in avoidance of subsistence harvest of marine resources. Avoidance of subsistence harvests due to the use of chemical dispersants

and in-situ burning could cause long-lasting and widespread adverse impacts to community health and well-being.

Effects to community organization and capacity to provide healthcare services can occur due to local employment in spill response and cleanup activities. A sudden increase in employment in spill response and cleanup work could have long lasting and widespread effects, including displacement of Alaska Native residents from their normal subsistence harvests, processing, and distribution activities. Increased employment of local residents could place stresses on community infrastructures such as hospitals and health clinics by drawing away local workers from community service jobs or increased medical visits from outside cleanup workers. These changes could increase healthcare demands, crime and injury rates, and social conflicts between local residents and outsiders. The deterioration of social relationships, anxiety, stress, and depression may result from long-term and widespread spill response and cleanup operations, making routine stress-coping strategies ineffective at the local level and contributing to compromised community health (Palinkas et al., 1993; USDOJ, BOEM, 2015).

Overall, impacts to community health from spill response and cleanup activities are expected to be minor to moderate depending on the extent and location of the spill and to what extent subsistence harvest patterns, local institutions, and community resilience and health (Eykelbosh, 2014; USDOJ, BOEM, 2015).

Conclusion

Appendix C describes mitigation measures derived from lease stipulations, design features and BMPs the operator committed to, and requirements and BMPs that other agencies typically require (sections C-1 to C-3). BOEM's conclusions regarding impacts assume implementation of, and compliance with, the mitigation measures described in sections C-1 through C-3.

Availability of and access to subsistence foods and other local subsistence resources are critical determinants of community health and cultural well-being in the NSB. Potential impacts to community health from loss of subsistence bowhead harvests and other harvest opportunities could be moderate. Impacts of air pollution and emissions from routine construction, development, and production on community health are expected to be minor. BOEM anticipates negligible impacts on community health related to water quality. Beneficial impacts to community health from revenue and economic growth are expected to be negligible to moderate. Adverse impacts to community health related to economic growth would most likely be minor. Overall, impacts on community health as a result of the Proposed Action are anticipated to be negligible to moderate.

Effects to community health from small accidental spills occurring during the life of the Proposed Action are expected to be minor. For a large oil spill, impacts to community health for Nuiqsut could be major. Impacts to community health for Kaktovik and Utqiagvik from a large oil spill are expected to be moderate to major, depending on the size and location of a spill and whether or not impacts disrupt subsistence harvest activities for one or more seasons, alter local healthcare services, disrupt traditional sharing networks, and/or threaten cultural values and identities.

Impacts to community health from spill response and cleanup activities are expected to be minor to moderate depending on method of oil recovery and removal, extent and location of the spill, and extent of disruption to subsistence harvest patterns, social organization, local institutions, and community healthcare services. Minor to moderate effects from spill response and cleanup are not expected to change the overall impact conclusions for a large spill.

Government initiated unannounced exercises (e.g., oil spill drills), which are infrequent, of short duration, (<8 hours), and utilize existing equipment, would not alter impact conclusion for community health.

4.4.4.2. Effects of Alternative 2 on Community Health

Under Alternative 2, the no action alternative, potential impacts on subsistence activities, harvest patterns, and sociocultural systems would not occur for Nuiqsut, Kaktovik, or Utqiagvik. There would be no increases in food insecurity or adverse effects to cultural well-being from the Proposed Action under Alternative 2. Under the no action alternative, there would be no changes to employment, income, or tax revenue, and no small or large oil spills would occur. Therefore, there would be no adverse or beneficial impacts to community health under Alternative 2.

4.4.4.3. Effects of Alternative 3 on Community Health

In Alternative 3, the proposed LDPI would be relocated (Section 2.2.4). Alternative 3A would relocate the proposed LDPI one mile to the east into slightly deeper water, and Alternative 3B would relocate the proposed LDPI 1.5 miles to the southwest into slightly shallower waters managed by the SOA.

Alternative 3A: Relocate the LDPI approximately one mile to the east.

Alternative 3A could prolong potential impacts to community health especially if construction activities were extended into the fall whaling season for Nuiqsut and/or into a second summer construction season and hence the beginning of a second whaling season. Under 3A, effects to whaling for Nuiqsut from summer construction activities at the proposed LDPI would remain major (Section 4.3.3.3) but would be prolonged into a second whaling season, which could have severe and thus major impacts on community health through potential longer-term food insecurity, decreases in nutritional health, and compromised cultural well-being in Nuiqsut. This increase in summer construction time could also increase impacts on subsistence seal hunting from minor to moderate for Nuiqsut and Kaktovik, potentially causing long lasting and widespread, but less than severe, and thus moderate impacts to social organization and cultural identity in these villages, which could in turn increase adverse effects to community health. Adverse effects to community health from loss of bowhead whale harvests could increase from moderate to major under Alternative 3A.

Alternative 3A would increase emissions of harmful air pollutants due to longer construction time (Section 4.2.3). Impacts of Alternative 3A on air quality would increase from minor to moderate for routine activities associated with the Proposed Action (Section 4.2.2.3). However, BOEM does not expect impacts to community health related to emissions of air pollutants to increase under Alternative 3A. Nuiqsut, Kaktovik, Barrow, and Prudhoe Bay are not expected to be exposed to increased air pollutants because they are located outside the area where moderate air quality impacts are expected to occur under Alternative 3A.

Alternative 3B: Relocate LDPI 1.5 miles to the Southwest (Closer to Shore).

If Alternative 3B allowed summer construction at the proposed LDPI to cease by August 25, impacts to whaling for Nuiqsut from LDPI slope protection work could be reduced from major to moderate. If Alternative 3B allowed summer construction at the proposed LDPI to cease by July 25, impacts to whaling for Nuiqsut from LDPI slope protection work could be reduced from major to negligible. This change could also reduce potential impacts to subsistence seal hunting from minor to negligible for Nuiqsut and Kaktovik hunters. Ceasing summer construction work at the proposed LDPI by July 25 would most likely reduce impacts to community health and sociocultural systems, especially for Nuiqsut. Due to potentially less impacts to subsistence harvests, Alternative 3B could decrease adverse impacts to community health related to loss of subsistence harvests from moderate to minor.

Alternative 3B would increase impacts to air quality due to a smaller area for dispersion and substantially increased emissions of pollutants (Section 4.2.3.3). However, BOEM does not expect impacts to community health related to emissions of air pollutants to increase under Alternative 3B. Nuiqsut, Kaktovik, Barrow, and Prudhoe Bay are not expected to be exposed to increased air

pollutants because they are located outside the area where major air quality impacts are expected to occur under Alternative 3B.

Alternative 3B would move the proposed gravel island and operations into waters managed by the SOA, which would increase property taxes (Section 2.2.4). Some of the increased revenue to the SOA from Alternative 3B could benefit the communities of the NSB. Added revenue income to the NSB could benefit Nuiqsut and other communities through improved healthcare and education and increased employment opportunities for residents of the NSB. Increased revenue could cause short term minor and beneficial effects to community health and sociocultural systems for Nuiqsut and other communities in the NSB.

Conclusion for Alternative 3A

Most impacts of Alternative 3A on community health would be the same as those for the Proposed Action (Section 4.4.4.1) with the exceptions of potential effects of loss of subsistence bowhead harvests and seal hunting opportunities. Under Alternative 3A, BOEM anticipates that impacts to community health would be moderate to major.

Impacts to community health as a result of NPDES-permitted discharges under Alternative 3A would be the same as for the Proposed Action, which are negligible to none.

Conclusion for Alternative 3B

Some impacts of Alternative 3B on community health would be the same as those for the Proposed Action (Section 4.4.4.1). BOEM expects some effects to community health to change under Alternative 3B. There could be a reduction in impacts to subsistence whaling due to decreased construction time. Overall, BOEM expects negligible to moderate adverse impacts to community health for Nuiqsut and Kaktovik under Alternative 3B due to a decrease in adverse impacts to subsistence activities. BOEM anticipates minor beneficial effects to community health in the NSB due to increased revenue.

Impacts to community health as a result of NPDES-permitted discharges under Alternative 3B would be the same as for the Proposed Action, which are negligible to none.

4.4.4.4. Effects of Alternative 4 on Community Health

Under Alternative 4, oil and gas processing would be relocated to one of two alternate facilities (Section 2.2.5). Alternative 4A would relocate oil and gas processing activities to Endicott. Alternative 4B would relocate oil and gas processing to a new onshore facility near the Badami pipeline tie-in.

Both Alternative 4A and 4B would reduce the construction time for the proposed LDPI, perhaps by as much as 20 days. Decreasing summer construction activities at the LDPI related to LDPI slope protection could substantially reduce impacts to subsistence harvest patterns and sociocultural systems, thereby potentially reducing adverse impacts to community health related to food insecurity and compromised nutritional health and cultural well-being.

Alternatives 4A and 4B would most likely reduce the overall noise produced at the proposed LDPI. Overall, BOEM does not anticipate any direct added advantage or reduced impact to community health from this reduction in offshore noise. However, substantial reduction of noise at the offshore LDPI would most likely reduce whalers anxieties over noise associated with their knowledge and experience of how noise decreases bowhead whaling success. Alternatives 4A and 4B would most likely decrease negative perceptions of noise in the marine environment. Reducing or eliminating the pervasive fear of noise in the marine environment could lower community stress, strengthen cultural identity and values, and improve overall community well-being and thus could benefit community health, especially in Nuiqsut.

Both Alternatives 4A and 4B would increase tax revenue for the SOA and the NSB. BOEM expects minor beneficial impacts to community health under Alternative 4 due to increased revenue and economic growth.

Conclusion for Alternatives 4A and 4B

The overall adverse effect on community health under Alternatives 4A and 4B is expected to be less than that for the Proposed Action due to lower impacts to subsistence harvests and less psychological stress on whalers and whaling crews. BOEM anticipates that Alternative 4 would have a minor adverse effect on community health due to reduced impacts to subsistence whaling. Under Alternative 4, there would be a minor beneficial effect on community health from increased tax revenue.

Impacts to community health as a result of NPDES-permitted discharges under Alternatives 4A and 4B would be the same as for the Proposed Action, which are negligible to none.

4.4.4.5. Effects of Alternative 5 on Community Health

Alternative 5 would relocate the proposed gravel mine (Section 2.2.6). There are three alternate mine sites, including two new sites, Alternatives 5A and 5B, east of the Kadleroshilik River and Alternative 5C, the existing Duck Island mine site in the Sagavanirktok River Delta.

BOEM anticipates that overall adverse impacts from Alternatives 5A and 5B on community health would not change from those described under the Proposed Action, which are minor to moderate (Section 4.4.4.1).

Alternative 5C would most likely increase construction time for the LDPI, possibly into a second season. This could prolong impacts to subsistence whaling for Nuiqsut and increase adverse effects to seal hunting for Nuiqsut and Kaktovik, which could in turn increase adverse impacts to community health.

Conclusion for Alternatives 5A and 5B: Adverse impacts from Alternatives 5A and 5B on community health would be minor to moderate.

Conclusion for Alternative 5C: Most impacts of Alternative 5C on sociocultural systems would be the same as those for the Proposed Action (Section 4.4.4.1) with the exception of potentially increased effects of summer construction activities at the LDPI on bowhead whaling and seal hunting. This would most likely increase adverse impacts to community health related to loss of subsistence harvests opportunities from moderate to major, especially in Nuiqsut. BOEM expects overall effects to community health to be moderate to major under Alternative 5C.

4.4.5. Environmental Justice

Overview

Oil development and production can have environmental and social consequences that are disproportionate across populations (O'Rourke and Connolly, 2003). Iñupiat people living on the North Slope have the potential to be affected by the Proposed Action and alternatives due primarily to their reliance on local natural resources for health, nutrition, social organization, cultural identity, and well-being.

This section describes potential disproportionately high and adverse effects from activities associated with the Proposed Action and alternatives for three environmental justice (EJ) communities: Nuiqsut, Kaktovik, and Utqiagvik. These are considered EJ communities on the basis of their proportional minority membership as compared to the SOA as a whole (i.e., Alaska Native peoples, specifically Iñupiat) (Section 3.3.5.3; CEQ, 1997).

4.4.5.1. Effects of The Proposed Action on Environmental Justice Communities

Subsistence continues to be the central organizing element of Iñupiaq society, and it is primarily through damage to subsistence resources and disruptions to subsistence activities and harvest patterns that environmental justice concerns can be assessed for Iñupiaq communities located on the North Slope. The Proposed Action has potential to affect subsistence harvest patterns in the central Beaufort Sea and coastal areas (Table 4.4.1-1; EDAW AECOM, 2008; Galginaitis, 2014b; USDO, MMS, 2002, p. 10). Any major disruptions to local subsistence practices (Section 4.3.3), sociocultural systems (Section 4.3.1), or community health (Section 4.3.4) from the Proposed Action could cause disproportionately high and adverse impacts to these EJ communities.

As described in Chapter 3, global climate change could alter current conditions in the Proposed Action Area during the 25-year life of the Proposed Action. BOEM anticipates little to no and thus negligible changes to the potential impacts of the Proposed Action to subsistence activities and harvest patterns and sociocultural systems due to observed environmental variability and a shifting baseline in environmental conditions (Section 4.4.1.1). This is because the social and cultural conditions exist as a shifting baseline. For example, subsistence hunters have been able to adapt to some of these changes by improved equipment and changes in the timing of hunting; moreover, marine mammals appear to be adjusting to a longer open-water period (Huntington, Quakenbush, and Nelson, 2016). BOEM predicts that the social-ecological system in the North Slope would adapt to shifting environmental conditions over the 25-year life of the Proposed Action. BOEM does not anticipate, in this relatively short timeframe, that climate change would alter the impacts of the Proposed Action to EJ communities.

The Proposed Action could cause disproportionately high and adverse impacts to EJ communities through a number of means, including:

- Major impacts to subsistence harvest patterns
- Major impacts to sociocultural systems
- Major impacts to community health

As analyzed in Section 4.3.3, if anticipated impacts to subsistence harvest patterns were to occur, the highest potential for changes to the sociocultural system and community health would be in the community of Nuiqsut with likely impacts to the sociocultural system reaching Kaktovik and possibly Utqiagvik, especially in the event of a large oil spill.

The primary subsistence activity that could be adversely affected by the Proposed Action is bowhead whaling conducted by crews from Nuiqsut near Cross Island (Table 4.4.1-1). If major impacts occurred from the Proposed Action, such as from summer construction at the LDPI or whaler avoidance (Section 4.3.3.1), BOEM expects disproportionately high and adverse impacts to occur for Nuiqsut. If major effects occur from small spills to subsistence harvest patterns, BOEM anticipates disproportionately high and adverse impacts for Nuiqsut. If major impacts from a large spill occur to Cross Island whaling, BOEM expects disproportionately high and adverse impacts for Nuiqsut.

The Proposed Action and small and large oil spills could have some major effects on the sociocultural system in Nuiqsut (Section 4.3.1). If these major effects to social organization, cultural values, and local institutions occur, BOEM anticipates disproportionately high and adverse impacts to the Nuiqsut.

In the event of a large spill, moderate to major impacts are expected to occur for whaling for Kaktovik and Utqiagvik crews (Table 4.4.1-1). BOEM expects severe and thus major impacts on sociocultural systems lasting more than one year for Kaktovik and Utqiagvik if their bowhead whaling areas are contacted by oil from a large spill. If these major impacts occur to sociocultural

systems, BOEM anticipates that a large spill could have disproportionately high and adverse impacts in Kaktovik and Utqiagvik.

BOEM anticipates major impacts to community health to occur as a result of a large oil spill for Nuiqsut and moderate to major effects to community health for Kaktovik and Utqiagvik (Section 4.4.4.1). If these major impacts occur to community health, BOEM anticipates that a large spill could have disproportionately high and adverse effects on EJ communities.

BOEM will continue to work closely with residents and leaders in Nuiqsut, Kaktovik, and Utqiagvik and Hilcorp Alaska, LLC to develop measures to address EJ concerns from the Proposed Action (Appendix C).

4.4.5.2. Effects of Alternative 2 on Environmental Justice Communities

Under Alternative 2, potential impacts on subsistence harvest patterns from disruptions to hunting and fishing and actual or perceived contamination of subsistence foods associated with the Proposed Action would not occur. There would be no impacts on sociocultural systems or community health for Nuiqsut, Kaktovik, and Utqiagvik. Therefore, there would be no disproportionately high and adverse impacts to EJ communities under Alternative 2.

4.4.5.3. Effects of Alternative 3 on Environmental Justice Communities

In Alternative 3, the proposed LDPI would be relocated (Section 2.2.4). Alternative 3A would relocate the proposed LDPI one mile to the east into deeper water, and Alternative 3B would relocate the proposed LDPI 1.5 miles to the southwest into shallower waters managed by the SOA.

Alternative 3A: Relocate LDPI Approximately One Mile to the East

Under Alternative 3A, BOEM anticipates that some major adverse impacts could occur to subsistence harvest patterns, sociocultural systems, and community health for Nuiqsut. Under Alternative 3A, BOEM expects disproportionately high and adverse environmental and health effects to occur in Nuiqsut if these major impacts occur to subsistence harvest patterns, sociocultural systems, and community health.

Alternative 3B: Relocate LDPI Approximately 1.5 miles to the Southwest

Under Alternative 3B, BOEM does not expect disproportionately high and adverse effects on EJ communities because reducing summer construction time at the proposed LDPI would most likely reduce impacts to sociocultural systems and community health, especially for Nuiqsut. Alternative 3B is not expected to have major adverse effects on sociocultural systems or community health for EJ communities.

4.4.5.4. Effects of Alternative 4 on Environmental Justice Communities

Under Alternative 4, oil and gas processing would be relocated to one of two alternate facilities (Section 2.2.5). Alternative 4A would relocate oil and gas processing activities to Endicott. Alternative 4B would relocate oil and gas processing to a new onshore facility near the Badami pipeline tie-in. Both 4A and 4B would reduce offshore construction times.

Under Alternatives 4A and 4B, BOEM anticipates that impacts to subsistence whaling for Nuiqsut would decrease. Decreasing summer construction activities at the proposed LDPI site related to slope protection could reduce impacts to whaling for Nuiqsut from major to moderate or negligible, depending on when summer construction at the LDPI ceased (Section 4.3.3.4). Under Alternatives 4A and 4B there would most likely be no major (i.e., high and adverse) impacts to subsistence whaling, therefore BOEM does not expect disproportionately high and adverse effects for EJ communities under Alternative 4.

4.4.5.5. Effects of Alternative 5 on Environmental Justice Communities

Alternative 5 would relocate the proposed gravel mine (Section 2.2.6). There are three alternate mine sites. Impacts from Alternatives 5A and 5B on EJ communities would be the same as impacts described for the Proposed Action (Section 4.4.5.1). Under Alternative 5C, BOEM anticipates some major impacts could occur to subsistence (Section 4.4.3.5) and sociocultural systems (Section 4.4.1.5) for Nuiqsut due to prolonged summer construction. Therefore, BOEM expects disproportionately high and adverse impacts for Nuiqsut. Overall, BOEM expects disproportionately high and adverse impacts for EJ communities under Alternative 5.

4.4.6. Archaeological Resources

Any offshore activity that disturbs the seafloor of the Beaufort Sea has the potential to affect archaeological and historic resources. Areas having high-density ice gouging are assumed to be of low potential for historic and prehistoric archaeological sites.

Although multiple lines of evidence indicate that this region had been occupied for approximately 10,000 years prior to the end of the Pleistocene, to date no archaeological sites have been discovered in the sub-seabed of what had been Beringia, the Land Bridge that linked the eastern coastline of Russia with the western coastline of Alaska (Hoffecker et al., 2014).

The National Historic Preservation Act of 1966 as amended (NHPA) and attendant Federal regulations that promulgate the NHPA, specifically 36 CFR 800, require that Federal agencies make reasonable and good faith efforts to identify historic properties within the area of potential from federally permitted, licensed, or funded onshore and offshore operations. Compliance with NHPA leads to:

- Identification of archaeological and historic resources
- Determination of eligibility for placement on the NHRP
- Assessment of adverse effects
- Resolution of adverse effects

NHPA requires that both direct and indirect effects to historic properties be considered. An example of a direct impact would be drilling through a buried archaeological site. An example of an indirect effect would be vandalism.

All of the activities described herein would require Federal approval and thus compliance with the NHPA and its implementing regulations. Identification of historic and prehistoric archaeological sites, the area of potential effect, mitigation, and monitoring measures would be accomplished in accordance with the NHPA and in consultation with the SHPO.

The discovery of an archaeological site within the area of potential affect from development would initiate the NHPA Sec. 106 process. First, the significance of the site would be assessed to determine eligibility for placement on the NRHP in consultation with consulting parties. In this case, consulting parties, as defined by 36 CFR 800 could include the Federal agency official, the Advisory Council on Historic Preservation, the State Historic Preservation Officer, federally recognized tribe, ANCSA regional corporation, ANCSA village corporation, local governments, and applicant. It is reasonable to assume that any archaeological site found buried below the seafloor of the Beaufort Sea would be considered eligible for placement on the NRHP because it could be associated with Beringian occupation.

The next step would include determination of effect of the Proposed Action. If the action were determined to be an adverse effect, mitigation methods would be developed. One outcome might be a realignment of planned activities to avoid the area of potential effect on the historic property; another might include excavation and analysis in accordance with NHPA.

As described in the previous chapter, multiple Geological and Geophysical (G&G) and acoustic remote sensing surveys conducted in the offshore resulted in multiple archaeological reviews, and on land, pedestrian and archaeological surveys were performed. No new archaeological sites were discovered within the footprint of the Proposed Action and the other action alternatives. However, there are previously identified archaeological and historical resources along the shoreline were pinpointed with Global Positioning Units (GPS).

4.4.6.1. The Proposed Action

The DPP includes the following ground disturbing activities:

- Development of Gravel mine site
- Construction of Liberty Development Production Island (LDPI)
- Installation of a 16-inch diameter pipeline both on- and offshore
- Dredged Material Disposal

All but one of the activities proposed under the Proposed Action have received archaeological surveys both on- and offshore as described in Chapter 3 (Figure 3.3.6-1). Archaeological survey techniques included multiple survey methodologies ranging from acoustic remote sensing and archaeological analysis of G&G cores in the marine environment to standard archaeological survey techniques, both pedestrian and air-born, of the lands proposed for development. Infrastructure surveyed included the proposed gravel mine sites, the LDPI sites, and the marine pipeline corridor. No surface or subsurface archaeological or historic sites were discovered, and BOEM anticipates that unless a post-review discovery is made, no historic properties would be affected by the proposed activities.

Proposed activities on the LDPI would not require additional archaeological review, since the LDPI would be manmade for this proposed development.

Construction of ice roads associated with the Proposed Action would not involve ground disturbance, and have no potential to cause effects to archaeological or historic resources.

HAK proposes to transport excess dredge spoils from the pipeline trenching activities to Prudhoe Bay for disposal in the nearshore area on the ice in the scour zone. The scour zone has natural high turbidity due to annual sediment removal by sea ice. Disposal of dredge materials would have negligible effects.

Facilities for small marine vessels would be located either at West Dock, Prudhoe Bay, or at the Endicott Satellite Drilling Island (SDI), a pre-existing manmade island created for the purposes of the Endicott field oil and gas development. None of these locations would have more than a negligible effect on archaeological or historic properties, since they would have no effect.

The area that has not received an archeological survey is the terrestrial pipeline, extending approximately 1.5 miles from the coast to tie-in with the Badami Oil Pipeline tie-in point. The pipeline would be elevated on Vertical Support Members (VSMs) with thermosiphons inserted to prevent melting of the permafrost. The proposed route was archaeologically surveyed in 2013 using a helicopter fly-over, limiting pedestrian surveys to higher potential ground, specifically elevated gravel pingos (Higgs, 2013). However, much of the vegetation along the proposed pipeline route is dry, rather than wet tundra tussock. The operator has agreed to have a pedestrian archaeological survey performed along the terrestrial pipeline route during the 2017 field season. If an archaeological or historic site is found, it is likely that it would be avoided or mitigated in conformance with 36 CFR 800. This survey would likely result in negligible to minor effects because parties would engage in consultation to reach resolution of effects if an archaeological or historic property is found that appears to eligible for the NRHP.

These proposed activities have the potential to cause effects ranging from negligible to major on prehistoric archaeological or historic resources, depending on the level of disturbance and the archaeological resource disturbed. The level of effect would depend on location and type of site, the type, magnitude, and duration of disturbance of the proposed action, and the season of the year. Effects would become more acute if the prehistoric archaeological or historic resources were found to be Historic Properties eligible for listing on the NHRP.

Accidental Oil Spills

An offshore oil spill of any magnitude is not anticipated to have a direct effect on any identified archaeological or historical site. An oil spill would not affect marine cultural resources because there are no reported shipwrecks in the area, and acoustic remote sensing did not discover archaeological or historic resources on the seafloor.

However, oil spills of any size could result in impacts to numerous archaeological and historic resources from response activities. These impacts could range from negligible to major. Cleanup crews might be needed in a number of locations. The greatest threat to archaeological and historic resources during an oil spill would result from the larger number of response crews being employed. Following the Exxon Valdez Oil Spill, most impacts to archaeological and historic resources that occurred during spill response were the result of vandalism or physical damage from spill response activities (Bittner, 1996; Reger et. al., 2000). Furthermore, timely monitoring of affected sites might not be possible, given the number of resources to be considered and personnel limitations (Reger et al., 2000).

The level of effect on the archaeology would depend not only on the magnitude of the spill and direct impacts to a resource, but the time of the year. If the spill were to occur when the ground was frozen or covered by snow, these factors would lessen potential impacts to archaeological sites. Thus, the effect of an oil spill could range from negligible through major, depending upon if historic properties were to be adversely impacted by the oil response.

Conclusion

Appendix C describes mitigation measures derived from lease stipulations, design features and BMPs to which the operator has committed, and requirements of Cooperating Agencies. Identification and protection of archaeological resources are components of lease stipulations required by BOEM and the State of Alaska (SOA). These mitigation measures have been assumed to be a part of the Proposed Action. The overall impacts of the Proposed Action to archaeological resources would be negligible unless an historic property or other as yet undiscovered site were to be inadvertently damaged during normal project activities or inadvertently damaged or vandalized during oil spill cleanup. Impacts to archaeological resources would then be major.

Mitigation Measures

Conveying the importance of avoiding Environmentally Sensitive Areas (ESA) (as recorded on an employee's GPS) could be part of new employee training, reinforced by discussing during safety meetings, or continuing employee development. This action would afford sites protection if all workers understood that they could not enter an ESA. These would be optimal actions to protect archaeological and historic resources through avoidance. This process could also be used in the event of a discovery, in consultation with the SHPO and consulting parties as per 36 CFR 800. With regard to previously identified sites along the coast, and if an as-yet undiscovered site is found, an additional mitigation measure would be to place a 100-foot buffer around documented sites, and enter them as ESAs in workers' GPS units. This action would afford sites protection if all workers understood that they could not enter an ESA. Conveying the importance of ESA avoidance could be part of new employee training, reinforced by discussing during safety meetings, or continuing employee

development. These would be optimal actions to protect archaeological and historic resources through avoidance.

4.4.6.2. Alternative 2 (No Action)

Under this alternative, the Proposed Action would not take place, nor would any action described in the Liberty DPP. Effects on archaeological and historic resources would be negligible.

4.4.6.3. Alternative 3 (Alternate LDPI Locations)

Alternative 3A: Relocate LDPI Approximately One Mile to the East

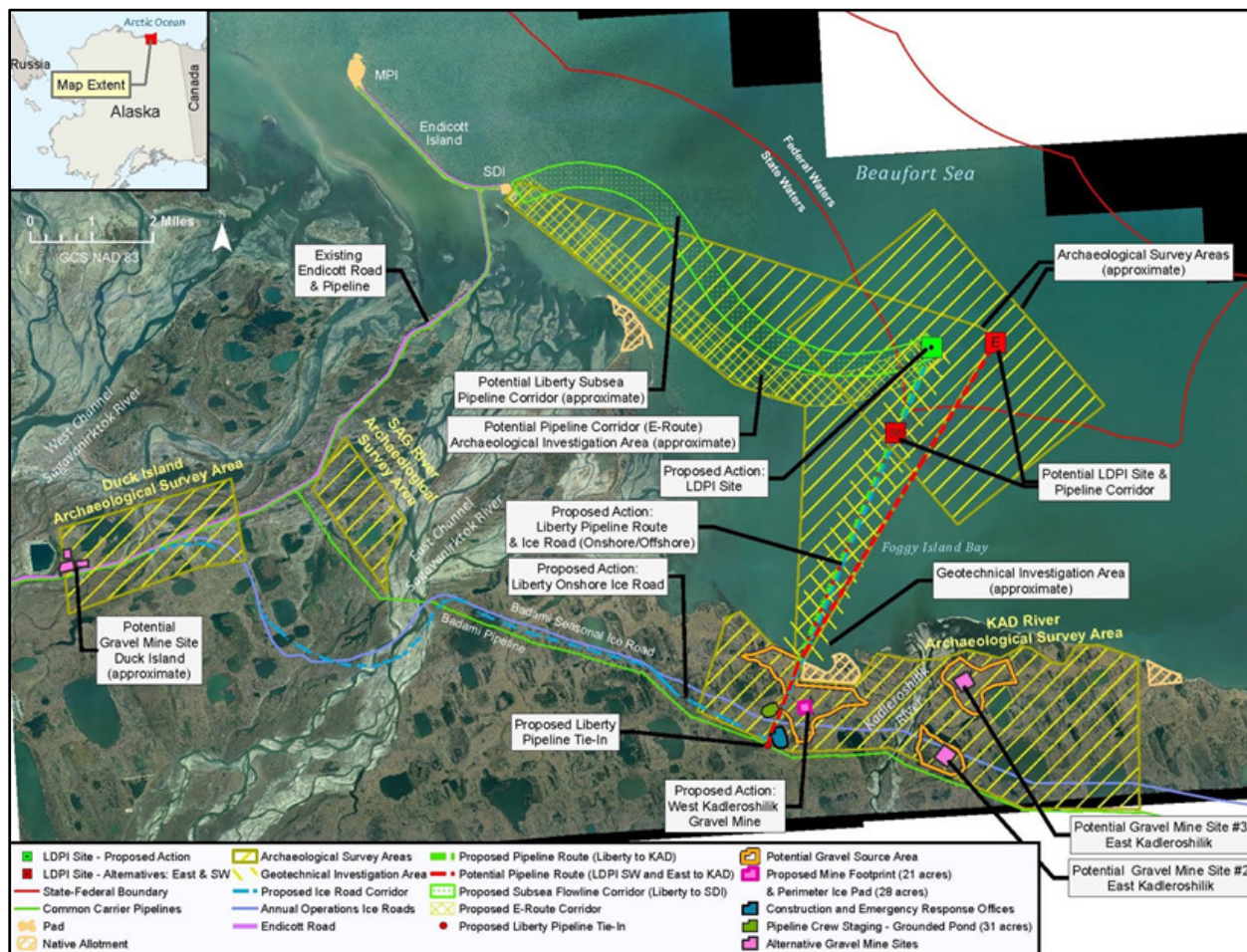

Figure 4.4.6-1. Proposed DPP Significant Archaeological Surveys.

Alternative 3A would relocate the LDPI to a site approximately one mile to the east (Figure 2.2.4-1). The potential marine pipeline corridor would be east of the pipeline corridor in the Proposed Action. The LDPI is in an area that has received remote acoustic sensing and archaeological analysis, and no surface or subsurface archaeological or historical sites being identified. However, neither the LDPI nor the proposed pipeline corridor has received a G&G survey that involved penetration of the seabed through coring, and thus there has been no archaeological or paleo-ecological analysis. It cannot be stated with as great of certainty that no historic properties would be affected as can be asserted for the Proposed Action. All potential actions would remain the same on land as described in the Proposed Action, and the recommendations would remain the same. Selection of Alternative 3A would include additional archaeological surveys, and Section 106 consultation under the NHPA. Effects could range

from negligible to major, depending upon if an archaeological site is discovered on- or offshore, and if the discovery is adversely impacted by ground disturbance.

As with the Proposed Action, the area that has not received a thorough archeological survey is the terrestrial pipeline, extending approximately 1.5 miles from the coast to tie-in with the Badami Oil Pipeline tie-in point. The operator has agreed to have a pedestrian archaeological survey performed along the terrestrial pipeline route during the 2017 field season. If an archaeological or historic site is found, it is likely that it would be avoided or mitigated in conformance with 36 CFR 800. It is difficult to assess effects because it is not known if there are sites along the pipeline corridor crossing land, and effects are considered to range from negligible to major, depending upon if an archaeological site is discovered, and if the discovery is adversely impacted by ground disturbance.

Conclusion

The overall impacts of Alternative 3A to archaeological resources would be negligible unless an historic property or other as yet undiscovered site were to be inadvertently damaged during normal project activities or inadvertently damaged or vandalized during oil spill cleanup. Impacts to archaeological resources would then be major. Similar to the Proposed Action, if an as-yet undiscovered sites are found or to protect known sites in the vicinity of the project, an additional mitigation measure would be it to protect the site by a 100-foot buffer zone to ensure they remain unaffected by field operations (Rogers, 2014). It is further recommended that the sites be programmed into all employees' GPS units as "Environmentally Sensitive Zones" to ensure that the sites are avoided throughout the life of the LDP. Doing so would likely result in negligible effects.

Alternative 3B: Relocate LDPI Approximately 1.5 Miles to the Southwest

Alternative 3B places the LDPI approximately 1.5 miles closer to shore into SOA waters and would be 1.5 miles from the proposed LDPI (Figure 2.2.4-2). The LDPI would likely require additional G&G coring to ensure stability, and would also be subjected to archaeological and paleo-ecological analysis of the new borings. The potential pipeline corridor is the same as the proposed pipeline corridor. All potential actions would remain the same on land as described in the Proposed Action, and the recommendations would remain the same. Selection of Alternative 3A would include additional archaeological surveys, and Sec. 106 consultation under the NHPA. Effects could range from negligible to major, depending upon if an archaeological site is discovered, and if the discovery is adversely impacted by ground disturbance.

The terrestrial pipeline would extend approximately 1.5 miles from the coast to tie-in with the Badami Oil Pipeline tie-in point. The pipeline would be elevated on VSMs and may use freeze-back technology to stabilize support members. The proposed route was archaeologically in 2013 but the archaeologists did so in a helicopter fly-over, limiting pedestrian surveys to higher potential ground, specifically elevated gravel pingos (Higgs, 2013). However, much of the vegetation along the proposed pipeline route is dry, rather than wet tundra tussock. The operator has agreed to have a pedestrian archaeological survey performed along the terrestrial pipeline route during the 2017 field season. If an archaeological or historic site is found, it is likely that it would be avoided or mitigated in conformance with 36 CFR 800. It is difficult to assess effects because it is not known if there are sites along the pipeline corridor crossing land, and effects are considered to range from negligible to major, depending upon if an archaeological site is discovered, and if the discovery is adversely impacted by ground disturbance.

Another area of concern is that there are known archaeological and/ or historic sites in the vicinity. None of these would be directly affected by any of the alternatives described herein. It has been recommended that the sites be protected by a 100-foot buffer zone to ensure they remain unaffected by field operations (Rogers, 2014). It is further recommended that the sites be programmed into all

employees' GPS units as "Environmentally Sensitive Zones" to ensure that the sites are avoided throughout the life of the LDP. Doing so would likely result in negligible effects.

Construction of ice roads associated with the Liberty project would not involve ground disturbance, and have no potential to cause effects to archaeological or historic resources.

Conclusion

Appendix C describes mitigation measures derived from lease stipulations, design features and BMPs to which the operator has committed, and requirements of Cooperating Agencies. Identification and protection of archaeological resources are components lease stipulations required by BOEM and the SOA. These mitigation measures have been assumed to be a part of the Alternative 3B. Alternative 3B would necessarily include archaeological surveys and analyses in conjunction with G&G coring and acoustic remote sensing surveys of the potential island. The overall impacts of Alternative 3B to archaeological resources would be negligible unless an historic property or other as yet undiscovered site were to be inadvertently damaged during normal project activities or inadvertently damaged or vandalized during oil spill cleanup. Impacts to archaeological resources would then be major.

4.4.6.4. Alternative 4 (Alternate Processing Locations)

Alternative 4A: Relocate Oil and Gas Processing to Endicott SDI

Alternative 4A would construct the proposed LDPI but processing would take place on the Endicott SDI. An alternative pipeline corridor would extend from the LDPI west to the SDI. Oil would be pumped through the existing Endicott Pipeline. The alternative pipeline corridor has received multiple surveys (Figure 2.2.5-1). It would be the only newly introduced component in Alternative 4A.

Alternative 4A would not require any further archaeological surveys. Effects would be negligible with little or no impact to archaeological and historical resources. The overall impacts of the Alternative 4A to archaeological resources would be negligible unless an historic property or other as yet undiscovered site were to be inadvertently damaged during normal project activities or inadvertently damaged or vandalized during oil spill cleanup. Impacts to archaeological resources would then be major.

Alternative 4B: Relocate Oil and Gas Processing to a New Onshore Facility

Alternative 4B would include all elements of the Proposed Action with the exception that a new onshore oil and gas processing facility would be constructed approximately 1.5 miles inland from the coast near the Badami Sales Oil Pipeline tie-in point. The facility would include production modules, custody transfer metering, sale oil pumps, and oil storage tanks, gas processing equipment for the LDP, a water treatment equipment, power generation, and a seawater treatment plant. The proposed site lies within the area surveyed for the Kadleroshilik River Mine site in 2013. The survey was a blend of low altitude, low speed airborne transects supplemented by pedestrian surveys of elevated pingos. No sites were found in the vicinity of what would now be the Badami Sales Oil Pipeline tie-in point (Higgs, 2013). A pedestrian archaeological survey would likely be necessary of the potential oil and gas processing facility if Alternative 4B is selected. Effects could range from negligible to major, depending upon if an archaeological site is discovered within the oil and gas processing footprint, and if the discovery is adversely impacted by ground disturbance.

Conclusion

The overall impacts of Alternative 4B to archaeological resources would be negligible unless an historic property or other as yet undiscovered site were to be inadvertently damaged during normal project activities or inadvertently damaged or vandalized during oil spill cleanup. Impacts to archaeological resources would then be major.

4.4.6.5. Alternative 5 (Alternate Gravel Sources)

Alternatives 5A, 5B, and 5C consider each of three different proposed gravel mine site locations. These alternative gravel mine sites received an archaeological survey that was comprised of low altitude, low speed airborne transects supplemented with pedestrian surveys of elevations. No archaeological or historic sites were discovered. The proposed action, would extract gravel from a site within the West Kadleroshilik River mine site. Alternative 5A is the East Kadleroshilik River mine site No. 2, which lies within the large Kadleroshilik River mine site that was surveyed archaeologically in 2013. No archaeological or historic sites were discovered (Higgs, 2013). Alternative 5B is the East Kadleroshilik River mine site No. 3. Alternative 5C, the Duck Island mine site in the Sagavanirktok River Delta, received an archaeological survey in 2013. No archaeological or historic sites were discovered (Higgs, 2013). As previously described, there are known archaeological and historic sites along the coast. As long as these areas avoided, the use of any of the Alternative 5 gravel sources would be viable. Effects on archaeological and historical resources would be negligible.

Conclusion

The overall impacts of the Alternatives 5A, 5B, and 5C to archaeological resources would be negligible unless an historic property or other as yet undiscovered site were to be inadvertently damaged during normal project activities or inadvertently damaged or vandalized during oil spill cleanup. Impacts to archaeological resources would then be major.

4.5. Very Large Oil Spill Scenario

4.5.1. Background

The potential environmental effects of a low-probability, high impact event—a hypothetical Very Large Oil Spill (VLOS) in the Proposed Action Area from the proposed Liberty development and production island (proposed LDPI)—are analyzed below. This VLOS analysis comprises three parts or sections:

- Section 4.5 (VLOS Scenario) describes a hypothetical VLOS scenario by providing background information and explaining the specific parameters that characterize the hypothetical VLOS.
- Section 4.6 is a summary of recovery and cleanup actions following a hypothetical VLOS.
- Section 4.7 analyzes potential environmental impacts that could occur in the very unlikely event of such a hypothetical VLOS in the Beaufort Sea.

4.5.2. OCS Well Control Incidents

A VLOS is not estimated to occur during the life of the development project and would be considered well outside the normal range of probability, despite the inherent hazards of oil development related activities. BOEM (2012, Section 4.3.3) provides a detailed discussion of the OCS well control incidents and risk factors that could contribute to a long duration loss of well control. General risk factors include geologic formation and hazards; water depth, geographic location; well design and integrity; loss of well control prevention and intervention; scale and expansion; human error; containment capability; response capability; oil types and weathering/fate; and specific regional geographic considerations, including oceanography and meteorology.

A VLOS is a subset of large spills (large spills are defined in Section 4.1.1.2), which is sometimes also called catastrophic. For the 2017-2022 Five-Year Program Final PEIS (USDOI, BOEM, 2016), BOEM defined a reasonable range of potentially catastrophic OCS spill sizes by applying extreme value statistics to historical OCS spill data (Ji et al., 2014). Extreme value statistical methods and

complementary methods (Bercha Group, 2014) were used to quantify the potential frequency of different size spills following loss of well control.

BSEE defines a loss of well control in the context of its incident reporting requirements (30 CFR 250.187 and 250.188), as uncontrolled flow of formation or other fluids underground (underground blowout) or at the surface (surface blowout) during all types of operational phases (exploration, development, and/or production operations) (USDOJ, BOEM, 2016, Figure and Table 3.3-1). In combining the estimated per well spill frequency (2.46×10^{-5} spills per well) for spills greater than or equal to the VLOS volume (the VLOS volume is assumed in this analysis to be 4,610,000 bbl (4.6 MMbbl) and is explained in greater detail below) with the estimated total number of potential wells that penetrate the reservoir, 14 (6 injector and 8 producer wells (Hilcorp, 2015a, Section 2.2 (page 7))), no very large spills are estimated to occur over the life of the development project. The per well frequency of spills caused by a loss of well control incident equal to or exceeding the VLOS volume of 4,610,000 bbl is derived using the equation from 2017-2022 Five-Year Program Final PEIS (USDOJ, BOEM, 2016). In applying the per well spill frequency resulting from a loss of well control event (USDOJ, BOEM, 2016) to estimate the likelihood of a hypothetical VLOS specifically from the Liberty Development project, it is important to note that the OCS spill database used to derive the per well spill frequency includes spills from exploratory wells, whereas the wells drilled at Liberty are developmental wells. The frequency of a loss of well control event (a potential precursor to a spill) was higher for exploration wells in the US GOM OCS than that of development wells from 1980-2011 in the same region (Bercha Group, 2014); therefore, the application of the per well spill frequency (USDOJ, BOEM, 2016) may overstate the likelihood of a hypothetical VLOS.

The hypothetical VLOS volume of 4.6 MMbbl referenced above is based on Hilcorp's estimate of a worst case discharge (WCD) volume which was independently verified by BOEM (see the following discussion and DPP Section 14.3 for additional information).

As a supplement to the above hypothetical VLOS occurrence estimation, BOEM includes a separate metric for estimating the likelihood of a spill greater than 150,000 bbl (distinguished from a hypothetical VLOS) which is based on developmental wells and does not include exploration well spill data. Bercha Group, Inc., modified the historic loss of well control frequency (that lead to spills greater than or equal to 150,000 bbl) for OCS development wells by accounting for Arctic conditions; the loss of well control frequency is estimated to be 4.4×10^{-6} spills per well (Bercha Group, 2016). In combining this per well spill frequency with the number of potential wells drilled into the reservoir (14 wells), no spills over 150,000 bbl are estimated to occur as a result of the project.

Taking into account the low chance that a development well (production or injector well) would experience a loss of well control (see above estimates) which then escalates into a long duration blowout, coupled with the observed low incidence rates for accidental discharges in the course of actual drilling operations, BOEM estimates a very small, but not impossibly small, chance for the occurrence of a VLOS event. But this consideration of probability is not, nor should it be, integrated into the VLOS model. The hypothetical VLOS discharge quantity is "conditioned" upon the assumption that all of the necessary chain of events required to create the VLOS actually occur (appropriate geology, operational failures, escaping confinement measures, the spill reaching the environment, etc.). The hypothetical VLOS discharge quantity is, therefore, not "risky" or reduced by the very low frequency for the occurrence of the event.

4.5.3. Hypothetical VLOS Scenario

As part of the Development and Production Plan (DPP), the operator has submitted an estimation of a WCD volume. The WCD estimation is required by 30 CFR Part 550.213(g) to accompany an Exploration Plan or a Development and Production Plan and provide a basis for an Oil Spill Response Plan in accordance with 30 CFR Part 254.47. The WCD volume information submitted by the

operator and independently verified by BOEM provides the basis for the volume used in the VLOS scenario.

The VLOS scenario is predicated on an unlikely event—a loss of well control during developmental drilling that leads to a VLOS. BOEM bases the VLOS volume estimate on Hilcorp's estimated worst case discharge from a loss of well control incident during developmental drilling (See DPP Section 14.3). Hilcorp estimates that, in this worst case scenario, 4.6 MMbbl could spill over the course of 90 days (Hilcorp, 2015, Table 14-3) assuming that the hypothetical loss of well control was stopped by a relief well rather than other proposed well control methods which have shorter estimated times to stop the spill. In addition to the 90 day oil spill volume, Hilcorp estimated a first day oil spill volume of 91,219 bbl and a first day gas spill volume as 84,538,512 scf (Hilcorp, 2015, Table 14-3). The (American Petroleum Institute (API) gravity of the oil discharged from the well is estimated to be 27° API (Hilcorp, 2015, Appendix I). As stated, the duration of the hypothetical spill resulting from a blowout depends on the time required for successful intervention and response. The spill's duration of 90 days is the total estimated time it could take to mobilize a second rig, drill the relief well, and then kill the blowout. Hilcorp estimates that it could take between 10 to 30 days to mobilize a relief rig and then an additional 30 to 60 days to drill a relief well and kill the blowout. A technique proposed by Hilcorp as a response to controlling a blowout but not considered in this hypothetical VLOS scenario is well capping (discussed in Section 4.6.2). Hilcorp states that well capping could regain well control in a total of 10 to 20 days versus this VLOS scenario, which has a duration of 90 days to control the blowout through relief well drilling. Further, Hilcorp's estimated WCD volume and this hypothetical VLOS scenario do not take into account the proposed blowout response technique of well ignition, which could reduce the amount of oil spilled. For example, Hilcorp estimates that 90% of oil can be combusted by well ignition (See Hilcorp DPP section 14.3.1.1 and 14.3.2.1). For additional information on Hilcorp's blowout prevention and well control procedures, see DPP Appendix H, DPP Section 8, and DPP Section 14.1. The intervention methods not included in this hypothetical VLOS scenario (i.e., well capping and well ignition) are discussed generally below in section 4.6.2

Hilcorp's WCD estimate is developed based on assumptions summarized in DPP Section 14.3. The volume of worst case discharge is the daily production volume summed over 90 days from an uncontrolled blowout of the highest capacity well that could be drilled into the reservoir. Some of the WCD assumptions that Hilcorp uses are that the blowout preventer systems fail, the wellbore is absent of drilling mud, and the open hole does not collapse. BOEM Office of Resource Evaluation (ORE) completed an independent verification of Hilcorp's worst case discharge model. ORE's verification included constructing a geologic model for the Liberty reservoir using commercially-available reservoir simulation software (MERLIN) which when combined with tubing flow curves generated by the interdependent wellbore nodal analysis software (AVALON) estimates the flow of fluids from the reservoir into the well and released at the wellhead.

Hilcorp references the Alaska Clean Seas Technical Manual for the modeling of an uncontrolled surface blowout (Alaska Clean Seas, 2015; Hilcorp, 2015). The blowout from the well causes an oil plume from the wellhead in the direction of the prevailing winds (Hilcorp, 2015). The gas flow rate, plume height, and size of the oil droplets can affect the fallout distribution of oil (Alaska Clean Seas, 2015). Other parameters that can affect the behavior of oil and gas after the initial blowout are turbulence in the atmosphere and oil particle settling velocity (S.L. Ross, 2000). Larger droplets of oil would tend to land closer to the blowout source, while smaller droplets of oil would tend to fall farther downwind from the source (S.L. Ross and D.F. Dickins and Associates, 1998). Literature also provides estimates for the percentage of oil from a hypothetical spill that falls within a specified distance from the blowout source (Belore et al., 1998). Further, some of the oil from the blowout plume could evaporate or become suspended in the atmosphere depending on the size of the droplets (S.L. Ross and D.F. Dickins and Associates, 1998). For a surface blowout at Endicott Island, an

existing offshore island development in Alaska, BPXA assumed drops of oil less than a specified threshold size would be held aloft by atmospheric turbulence (BPXA, 2012).

Sections 4.5.2.1 through 4.5.2.3 describe the behavior of hypothetical oil spills after the initial blowout during three scenarios: open water, winter, and break-up and freeze-up.

4.5.3.1. Hypothetical VLOS Scenario for Open Water or Summer

An open-water or summer spill¹ would begin between approximately July 15 and October 1, based on the operator's proposed periods of reservoir drilling when a blowout could occur and associated seasonal restrictions when a blowout would not likely occur as reservoir drilling restrictions exist (see the 2015 Liberty DPP, Section 8.1 for seasonal drilling restrictions).

The oil from a hypothetical blowout would land on the open water (a similar assumption was made for a hypothetical Liberty surface blowout² analysis conducted by S.L. Ross Environmental Research Ltd. (See S.L. Ross, 2000)). Oil from a blowout could also fall on the proposed LDPI, and a percentage of this oil could drain into the open water (USDOJ, MMS, 2002). Movement of the oil that falls on the LDPI can potentially be affected by the LDPI grading plan which redirects flow of minor spills to sumps, where separators are located (See Hilcorp, 2015, Section 11.10). A sheet pile wall on the LDPI could provide a degree of containment based on a similar design used in another offshore Alaskan facility, Endicott Satellite Drilling Island (See BPXA, 2012; Table 1-17 in Response Action Plan). Oil that reaches the open water can be affected by wind, currents, and weathering processes (S.L. Ross and D.F. Dickins and Associates, 1998); specific weathering processes are discussed below in Section 4.5.4. Both tidal currents and longshore currents may affect the movement of oil (S.L. Ross and D.F. Dickins and Associates, 1998). The direction and velocity of the currents can influence the size of a slick (S.L. Ross, 2000).

During the open-water period, there could be intermittent ice floes (see 2016 Liberty Draft EIS Section 3.1.2.4 Sea Ice), and if oil was present in the water before the ice floes moved into the area of the spill, oil would flow around the ice and accumulate at the water surface (Lee et al., 2015). S.L. Ross predicted that oil from a blowout at Liberty could also fall on transitioning ice floes and would evaporate as opposed to spreading or emulsifying on the ice's surface (S.L. Ross, 2000).

4.5.3.2. Hypothetical Winter VLOS Scenario

A winter spill would begin between November 15 and June 1 based on the operator's proposed periods of reservoir drilling and associated seasonal drilling restrictions (see Hilcorp, 2015, Section 8.1). Another source of a spill during winter is a late season summer blowout. A late season summer blowout could begin around October 1st and last 90 days until a relief well is drilled, which could be during winter.

For a winter blowout, Hilcorp discusses how spill modeling has shown that the majority of oil would settle within 2 miles of the blowout, an area covered by landfast ice in mid-winter (Hilcorp, 2015; Alaska Clean Seas, 2015). Further, the oil from a blowout would have a high viscosity, rapidly spread, and gel (Hilcorp, 2015; S.L. Ross, 2000). A surface blowout during winter where a percentage of oil falls to the ground near the source can coat the surfaces of snow (Nelson and Allen, 1982; Belore et al, 1998; Buist et al., 2013). Some of the oil from the blowout that landed on the proposed LDPI could drain onto frozen ice (USDOJ, MMS, 2002). The roughness of the ice surface, wind speed, and volume of snow present are all parameters that can affect the areal extent of oil spilled onto ice (S.L. Ross and D.F. Dickins and Associates, 1998). A snow/oil mulch can form if oil is

¹ Another source of a spill during open water is a late season winter blowout. A late season winter blowout could begin around June 1st and flow for 90 days until a relief well is drilled during summer.

² The surface blowout size that SL Ross analyzed was 5,500 barrels of oil per day.

spilled during snowfall or if snow blows onto an oil pool (McMinn and Golden, 1973). If oil is spilled on snow covered [land fast] ice, it can move below the snow to the ice layer (Lee et al., 2011). If oil spills under ice in late winter, due to the slowed growth rate of new ice at this time, it would most likely not become encapsulated within the ice (TRB and NRC, 2014). An oil spill during mid-winter may be contained on the stable ice cover (Buist et al., 2013); therefore, it may be possible for the spill to be cleaned up using proposed recovery methods (See Section 4.6) and thus not contact any resources.

4.5.3.3. Hypothetical VLOS Scenario for Break-Up and Freeze-up

While a loss of well control incident during developmental drilling leading to a blowout and a hypothetical VLOS is not estimated to occur in the shoulder seasons (freeze-up or break-up) due to restrictions on reservoir drilling by the operator, the spill resulting from an open water or winter blowout may persist into the freeze-up or break-up periods.

The behavior of oil in sea ice can vary depending on the concentration of ice present. For example, if spilled oil is present in 30% or greater concentration of ice, the oil can drift with the ice (Lee et al., 2011). The behavior of oil in sea ice concentrations less than 30% can be similar to that of oil in open-water conditions (Venkatesh et al., 1990; Brandvik et al., 2006). In ice concentrations greater than 50%, oil may be restricted to spreading between ice floes, if present (S.L. Ross and D.F. Dickins and Associates, 1998). With respect to oil's potential contact with icy shorelines, it is generally dependent on the time at which it spills. For example, if oil comes in contact with a shoreline before ice formation, it can remain trapped there until the melting season, whereas, if the oil arrives after ice formation, it can be kept off of the shoreline (Fingas, 2015).

If spilled oil is present when new ice is forming during freeze-up, it can become encapsulated within the ice structure and remain trapped until spring (Lee et al., 2011), or it can remain on top of the ice as the ice forms (Lee et al., 2015). The weather conditions during freeze-up can affect the fate and behavior of oil. For example, winds during storms can break up ice that had initially entrained the oil and displace it until the next freezing cycle (the next freezing cycle typically occurring within hours or days) when it can then get re-encapsulated (S.L. Ross and D.F. Dickins and Associates, 1998). The migration of oil through brine channels and the melting of the ice sheet are two common ways in which encapsulated oil can become released during spring (Lee et al., 2011). During spring, encapsulated oil can migrate up through brine channels and form pools on the surface of the ice (Lee et al., 2011). Trapped brine within the sea ice can create vertical channels for oil to migrate through when temperatures rise (Dickins and Buist, 1999). When oil reaches the surface of the ice after it has migrated up through brine channels, it can be absorbed by the overlying snow (if present) before increasing the absorption of solar radiation on the ice to form oil melt pools (NORCOR, 1975). The pour point³ of Liberty crude oil (37°F) can affect the speed at which migration of the oil through brine channels takes place (S.L. Ross, 2000). The level of solar radiation can also affect the rate at which oil migrates up through brine channels, as demonstrated by observations of oil interactions with fast ice in Cape Parry in the Beaufort Sea (NORCOR, 1975). The migration may also be inhibited by the gelling tendency of the oil and in effect, remain encapsulated until the ice has melted down to its depth to expose it (S.L. Ross, 2000).

During spring breakup, rivers discharge freshwater on top of sea ice and landfast ice breaks off of the shore and melts (See BOEM 2016 Liberty Draft EIS Section 3.1.2.4). The overflowing of rivers would act to redistribute oil that was spilled on ice (Hearon et al., 2009). In another scenario, if oil is spilled into broken ice during spring-breakup, it can coat the ice surfaces or become contained within ice floes (S.L. Ross and D.F. Dickins and Associates, 1998).

³ The pour point is the temperature in which a fluid becomes semi solid and can no longer flow (Lee et al., 2015).

Based on laboratory tests and spill observations, waves could move oil present in water to ice surfaces (Fingas and Hollebhone, 2003). In leads⁴, oil that was initially on the surface of the water could move to the surface of adjacent ice or underneath it, depending on the lead closure rate (MacNeil and Goodman, 1987; Lee et al., 2011); however, analysis of lead pumping (i.e., the redistribution of oil from water to the ice) in the Beaufort Sea has shown that it is rare for oil to get on top of the ice, rather it would likely end up underneath the ice (Fingas, 2015). If oil were to get underneath the ice, it could form reservoirs and subsequently become separated from the ice surface by under-ice currents, if currents were of sufficient velocity (Lee et al., 2011). The surface roughness of the ice can determine the holding capacity of oil; for example, the higher the surface roughness, the more oil that could be contained within cavities (Drozdowski et al., 2011). The under-ice storage capacity of oil underneath landfast ice can vary depending on the time during winter; for example, later season ice can have greater storage capacities than earlier, smoother season ice (Kovacs et al., 1981; Barnes et al., 1979; Dickins and Buist, 1999).

4.5.4. Fate and Behavior of an Oil Spill

The general weathering processes and behavior of oil in Arctic ice-free waters may include spreading, fragmentation into smaller sized slicks, evaporation, dispersion, emulsification, oxidation, sedimentation, biodegradation, and dissolution (Lee et al., 2011). In cold water or when ice is present, the weathering of oil can be slower or non-influential (TRB and NRC, 2014). During freeze up, specific weathering processes that can affect oil are evaporation, dissolution, emulsification, and dispersion (TRB and NRC, 2014). The fate and behavior of oil spilled under ice may include spreading, evaporation, dispersion, emulsification or biodegradation and these processes can be slower or non-influential (Lee et al., 2015).

Horizontal transport takes place via spreading, advection, dispersion, and entrainment while vertical transport takes place via dispersion, entrainment, Langmuir circulation, sinking, overwashing, partitioning, and sedimentation (USDOJ, MMS, 2007b, Appendix A, Figure A.1-1 and Figure A-2). The persistence of an oil slick is influenced by the effectiveness of oil-spill response efforts and affects the resources needed for oil recovery (Davis et al., 2004). The persistence of an oil slick may also affect the severity of environmental impacts as a result of the spilled oil.

Key weathering processes that may be relevant to the persistence of an oil spill in an Arctic marine environment are discussed below and are shown in Figures 4.5.4-1 and 4.5.4-2.

Spreading. Spreading refers to how oil is affected by a variety of physical properties (including viscosity, buoyancy, and surface tension) as well as how it moves. Oil may coalesce into a denser area known as a slick, and a thinner area known as a sheen that is concentrated along the outer portions of the slick (Lee et al., 2015; Drozdowski et al., 2011). The air and water temperature, wind, and wave state can affect how oil spreads (Lee et al., 2015). Due to the interfacial tension⁵ of Liberty crude, sheens are predicted to form on the water when oil is spilled even after considerable weathering (S.L. Ross, 2000). The presence of ice can limit the spreading of oil and concentrate slicks. The spreading of oil in ice depends on the amount and type of ice coverage. The oil film thickness can increase with higher ice coverage (Brandvik et al., 2006). Additional information on the spreading of oil in winter, summer, and freeze-up/break-up are discussed above in section 4.5, above.

Evaporation. Generally, evaporation causes the loss of the lighter components of the oil, and this process can affect its bulk properties (TRB and NRC, 2014). Evaporation of oil on ice during winter is slower compared to oil spilled in open water (Lee et al., 2011). The evaporation rate of oil is affected by the slick thickness, wind speed, and air temperature (Lee et al., 2011). The evaporation of

⁴ Leads are vessel navigable passages through sea ice (Fingas, 2015)

⁵ Interfacial tension or the forces between the oil-water and oil- air interfaces (SL Ross, 1998).

oil is affected by the surface area in contact with air (S.L. Ross, 2000) and can be inhibited by colder air temperatures (TRB and NRC, 2014). The presence and degree of compaction of snow (if present) can affect the evaporation rate for oil; in field experiments, evaporation was higher when no snow was present, slower in un-compacted snow, and slowest in the densest compacted snow (Belore and Buist, 1988).

At freezing temperatures, the evaporation of Liberty oil (a waxy crude oil) can be affected by the formation of skin around the surface of the slick during weathering. This skin can hinder lighter components within the oil from escaping the slick to the air (S.L. Ross, 2000). Experiments indicate this may occur when the oil has lost 20% of its volume by evaporation (S.L. Ross, 2000).

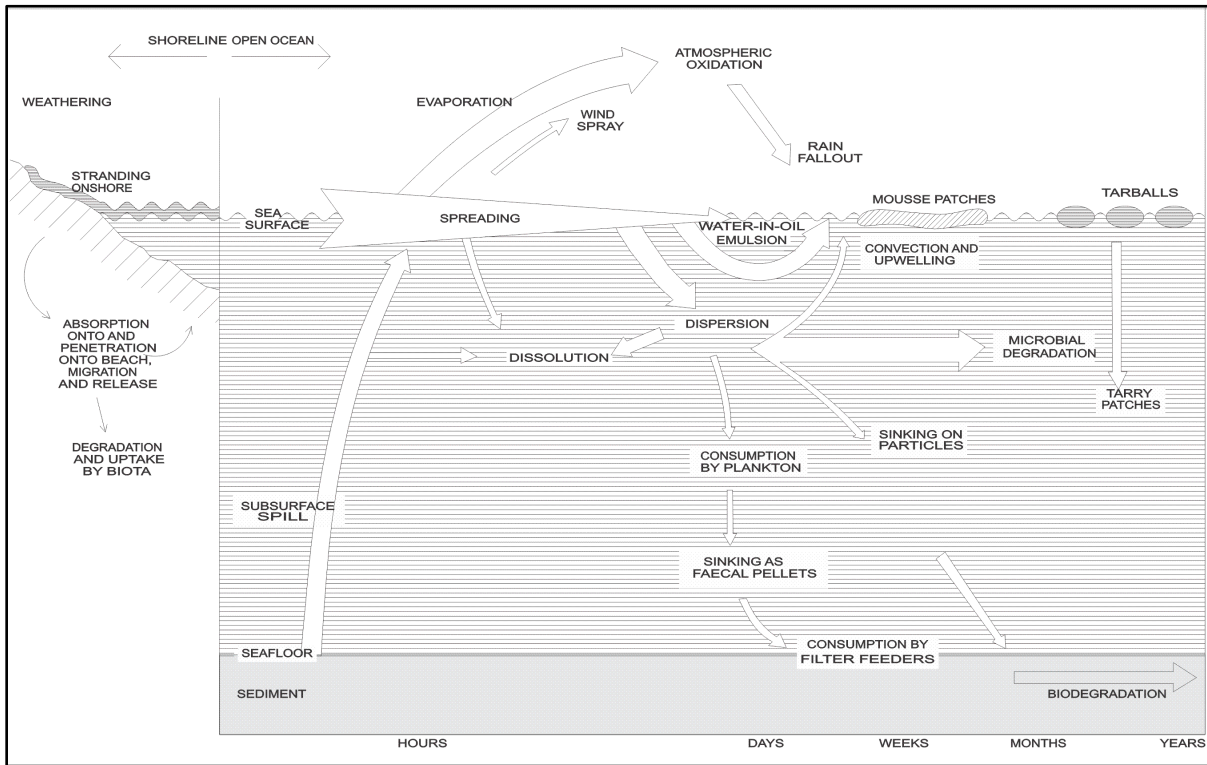

Figure 4.5.4-1. Oil Spill Weathering Processes and Behavior in an Arctic Open Water Environment (Modified from A. Allen, 1980).

Emulsification. Emulsification occurs when small droplets of one liquid, such as water, are suspended in another liquid, such as oil (Fingas, 2015; ITOPI, 2014). The cause of water-in-oil emulsion formation is thought to be sea energy (Fingas, 2015), or wave action (S.L. Ross, 2000). The viscosity⁶ of the oil at ambient temperatures, the availability and amount of mixing energy, and the asphaltene content can influence when an emulsion can form (MAR et al., 2008). Emulsification can increase the bulk volume of the spilled oil through the increased intake of water (S.L. Ross, 1998; Fingas, 2015; Lee et al., 2011). Three types of emulsions that generally form are unstable, mesostable, and stable emulsions (Fingas, 2015). Liberty oil is predicted to form stable emulsions (S.L. Ross, 2000). Both fresh and weathered Liberty crude oil formed stable emulsions in laboratory experiments conducted at 1° C (S.L. Ross, 1998). Stable emulsions are associated with higher viscosity, longer stabilization times, and the formation of mats (Fingas, 2015; S.L. Ross, 2000). The amount of ice present near the oil can affect the extent to which the crude emulsifies; higher ice

⁶ The viscosity of the oil slick can affect the amount of small droplets entering it; higher viscosity oil can prevent water from entering the slick (Fingas, 2015). Whether an emulsion forms after water has entered the oil slick is dependent among other factors such as the amount of asphaltenes and resins present (Fingas, 2015).

concentrations can dampen wave activity limiting the emulsifying process (S.L. Ross, 2000). In laboratory weathering experiments of an Endicott crude oil sample, considered an analogue for Liberty crude oil (S.L. Ross, 2000), it was shown that emulsion formation took place in the presence of varying ice concentrations with high wave energy (MAR et al., 2008). Spills of Liberty crude oil directly onto fast ice are predicted not to emulsify (S.L. Ross, 2000).

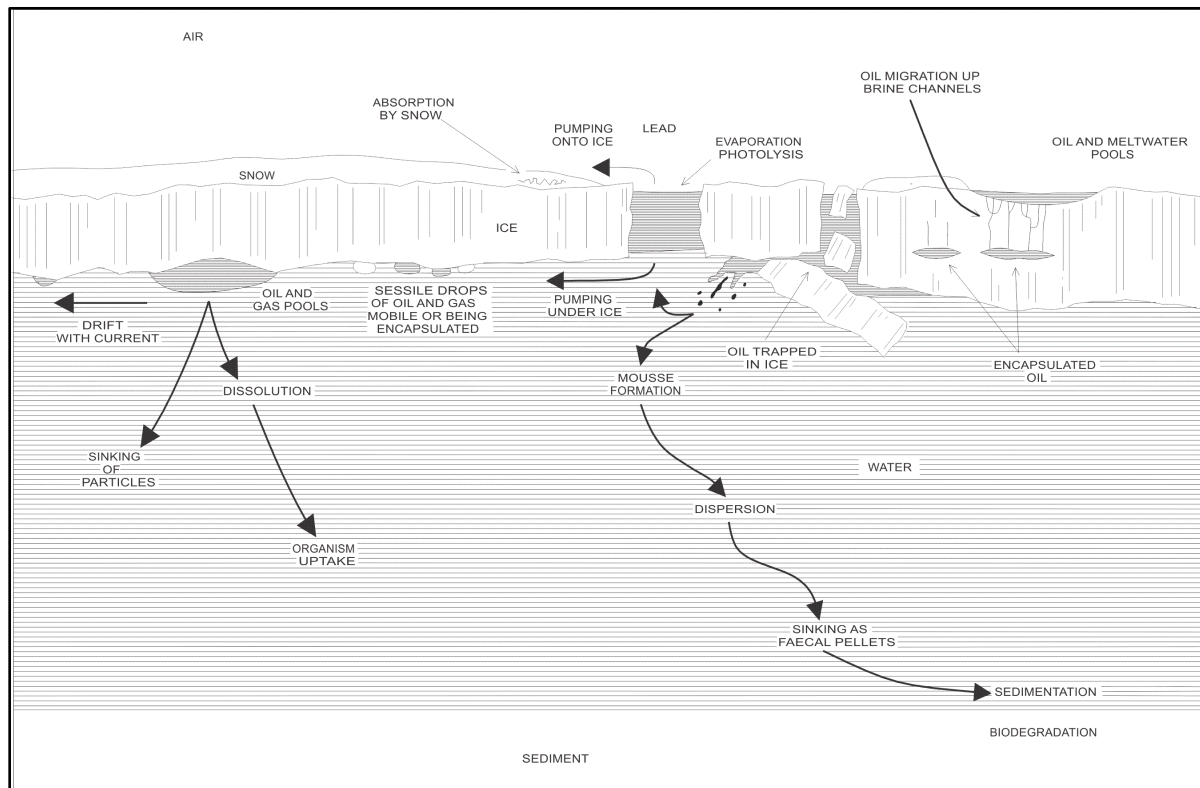

Figure 4.5.4-2. Oil Spill Weathering Processes and Behavior in an Ice-present Arctic Environment
(Modified from A. Allen 1980).

Natural Dispersion. Natural dispersion refers to the process by which waves or turbulence in the water moves oil from the slick into the water column (Lee et al., 2015; Fingas, 2015). Waves can break the oil into droplets of differing sizes which are dispersed into the shallower part of the water column (ITOPF, 2014). The rate of dispersion can depend on the sea state as well as the specific spilled oil properties (Lunel, 1995; Fingas, 2015). Dispersion of oil into the water column can make oil that was originally in the slick available for other weathering processes like dissolution or biodegradation (Brakstad et al., 2015; Prince, 2015; Lee et al., 2015). Spills on winter ice are assumed not to disperse based on predicted characteristics of Liberty crude oil (S.L. Ross, 2000).

Dissolution. Dissolution is the process by which water soluble compounds of the oil such as aromatics preferentially dissolve into the water (Faksness and Brandvik, 2008a; Fingas, 2015). Field experiments have been performed demonstrating the dissolution of oil through sea ice (Lee et al., 2011); the temperature of the air can affect the porosity of the ice and thus the rate of dissolution (Faksness and Brandvik, 2008b). Colder air temperatures promote more solid ice [as opposed to warmer temperatures causing higher porosity in ice], slowing the rate at which the water soluble compounds of the oil drop out of the ice (Faksness and Brandvik, 2008(a); Faksness and Brandvik 2008b; Lee et al., 2011).

Photooxidation. Photooxidation is the weathering process by which ultraviolet light (Lee et al., 2015) can create new products, such as resins, from the carbon and oxygen present in oil (Fingas, 2015).

Biodegradation. Biodegradation is the process by which microorganisms consume oil as a food source. Biodegradation rates are dependent on the type of hydrocarbon; aromatics and asphaltenes are biodegraded slower than saturates (Fingas, 2015).

Sedimentation. The sedimentation of oil can occur in the nearshore environment where sediment content is higher. Oil can interact with or attach to sediments in the water column and, as a result, become sequestered on the sea floor (Lee et al., 2011 and Fingas, 2015).

4.5.5. Hypothetical VLOS Conditional Probabilities and Trajectory Modeling

As summarized earlier in Chapter 4 (and described in detail in Appendix A), BOEM has conducted OSRA modeling to estimate the percent chance of a large spill contacting a particular resource within a particular time period and season from the Proposed Action Area. A particular resource may be described by ERAs, LSs, or GLSSs as shown in Tables A.1-A.11. BOEM uses the conditional probabilities from the large spill analysis to estimate the percentage of trajectories from a VLOS contacting biological, social, and economic resources of concern in and adjacent to the proposed action area. No special OSRA run was conducted to estimate the percentage of trajectories contacting resources from a blowout resulting in a VLOS.

Conditional probabilities resulting from the OSRA refer to the condition (assumption) that a VLOS has occurred. There are some differences between this VLOS analysis and BOEM's earlier analysis of a large oil spill in Section 4.1.1.2 of this Draft EIS. A long duration hypothetical VLOS would consist of a spill occurring continuously for up to 90 days (Hilcorp, 2015, Section 14.3). In this case, there would be multiple trajectories over time with each trajectory launched regularly as the well continued to flow. The multiple trajectories representing a hypothetical VLOS change how the conditional probabilities from the large spill analysis are interpreted. In this case, each trajectory models how some fraction of the hypothetical VLOS could spread to a specific resource or location. The conditional probabilities would represent how many trajectories come to that location, described as percent trajectories (number of trajectories contacting a location/total number of trajectories launched). A higher percentage of trajectories contacting a given location could mean more oil reaching the location depending on weathering and environmental factors. The terminology used hereafter is "percentage of trajectories contacting."

The operator proposed confining reservoir drilling to the estimated dates of July 15th through October 1st (open water time period designation by Hilcorp) and November 15th through June 1st (frozen ice time period designation by Hilcorp) Section 3.1.2.4 describes break-up beginning in late May and lasting through June or early July.; therefore, it is assumed the hypothetical VLOS begins in the open-water or frozen ice periods as opposed to beginning in either the freeze-up period or break-up period when the operator isn't conducting reservoir drilling. However, while the VLOS doesn't begin in the freeze-up or break-up periods, it could still flow during these periods (e.g., late season open water or winter blowout that lasts during the shoulder seasons). For this reason, BOEM assumes that conditional probabilities for the summer, winter, or annual time periods are applicable for the VLOS analysis. Further, as the operator states that it could take 90 days to drill a relief well, BOEM conservatively assumes that the time period in which to analyze contacts to resources is at least 90 days but can also be up to 360 days. The percentage of trajectories contacting resources within 90 and 360 days from a blowout leading to a VLOS (at Liberty Island) occurring annually, in summer, or in winter are provided in Tables A.2-5, A.2-6, A.2-11, A.2-12, A.2-17, A. 2-18, A.2-23, A.2-24, A.2-29, A. 2-30, A.2-35, A.2-36, A.2-41, A.2-42, A.2-47, A.2-48, A.2-53, and A.2-54. Within these tables, the trajectories contacting resources from Liberty Island (LI) are applicable because the blowout is assumed to occur from a well on the island.

The combined probabilities which are discussed earlier in Section 4 for the large spill analysis are not relevant to this VLOS analysis.

4.5.6. Gas Release

The quality and quantity of components in natural gas vary widely by the field, reservoir, or location from which the natural gas is produced. Natural gas is primarily made up of methane (CH₄) and ethane (C₂H₆) which make up 85-90% of the volume of the mixture. BOEM makes general assumptions about a hypothetical gas release as a result of the VLOS in the proposed action. The oil in the hypothetical VLOS scenario is assumed to have a gas-oil ratio (GOR) of ~927 scf/bbl, which BOEM estimated by dividing the first day gas volume of 84,538,512 scf by the first day oil volume of 91,219 bbl. Hilcorp (2015, Section 14.3) provides first day discharge volumes. For the hypothetical gas release volume to analyze, BOEM uses the estimated cumulative gas discharge volume over the VLOS duration of 90 days as the hypothetical gas release volume to analyze. The cumulative gas discharge over the 90-day spill period is estimated by multiplying the assumed GOR of 927 scf/bbl by the VLOS volume of 4.61 Mbbbl yielding 4.27 Bcf (billion cubic feet) of gas. This estimate uses a simplifying assumption that the GOR remains constant over the 90 day VLOS spill period.

4.6. Recovery and Cleanup

In the event of a large spill or hypothetical VLOS, response equipment and personnel would be mobilized from locations around the Prudhoe Bay industrial complex, followed by assets being pulled in from locations around Alaska and then other U.S. caches. Personnel would be berthed in available housing at the man-camps and hotels located across the North Slope, temporary man-camps that can be flown or barged in, and possibly airplane hangars at the Deadhorse airport. Camps at Badami and Point Thompson could also be used to house and accommodate workers in the event of a large spill and cleanup operation.

A spill occurring during the open-water season from late June through early November would result in the greatest level of activity. A hundred or more small and medium sized vessels (12 to 55 ft) would be employed to respond to the spill due to the shallow water depths near and around the LDPI. The use of an OSRV (Oil-spill response vessel) or ORSB (Oil-spill response barge) would be required to collect oil that spilled into the open ocean, and to serve as on-water storage for recovered fluids. The OSRB will have an associated tug and high-volume skimmers to recover oil (Hilcorp, 2015). Nearshore skimming vessels would use a boom that directs the oil to a skimmer which is then pumped into mini-barges (Hilcorp, 2015; Alaska Clean Seas, 2015, Tactic R-17). The OSRB, skimming vessels, and mini barges offload collected oil at Endicott SDI or proposed LDPI.

During the summer months, operations would run around the clock given the long periods of daylight. Responders would utilize several miles of various types and sizes of containment boom to control the spread of the oil on the water surface and to exclude or divert oil from contacting sensitive areas. Several hundred additional personnel would be required to conduct oil spill containment and recovery operations, and to support the responders with maintenance and camp services. A boom, deployed at the Endicott Causeway bridges (approximately 7.3 miles west-northwest from the proposed LDPI location), is used to collect oil in the Harbour buster collection point where these fluids are then pumped into a mini-barge or shoreside storage (Hilcorp, 2015; ACS tactic R-33). Shoreline and onshore recovery techniques include the use of workboats and airboats which deploy boom and anchors in Foggy Island Bay. Skimmers can then pump oil into temporary tanks (Hilcorp, 2015; Alaska Clean Seas, 2015, Tactic R-16).

During summer, in situ burning (ISB) could be employed as a response strategy in which oil at the sea surface is intentionally ignited. The operations can be monitored by air or ground. Oil is collected by boom that is either anchored to shore or towed on the water by tow boats. Once the oil is collected, it is ignited. An igniter boat and hand-held igniter with diesel and road flare are used to burn the oil. The amount of residue after a burn would depend on the environmental conditions and effectiveness of the burn (Hilcorp, 2015). The residue is characterized as being taffy-like and viscous and will

either be buoyant, negatively buoyant, or neutral (Hilcorp, 2015). The residue is collected into booms or nets, and then strainers, hand tools, skimmers or sorbents are used for picking up the material (Hilcorp, 2015).

On-water response efforts would continue until formation of ice prevented ready access to the oil. Unless the well was still flowing, response efforts would most likely be suspended until stable solid ice formed in the area. During the shoulder seasons, equipment including hovercraft, amphibious Haagland personnel/small equipment carriers, airboats, an amphibious Ditch Witch trencher, and amphibious backhoes would be used (Hilcorp, 2015). During freeze-up, skimmers would be deployed from bridges at Endicott causeway or from workboats. Skimmers could collect oil in pockets from broken ice (Hilcorp, 2015). During that transition period when vessels and skimmers become ineffective, ISB would be used to reduce the volume of oil in the environment. The oil on the ocean surface and on the shoreline would be encapsulated by the growing ice sheet. The use of tracking equipment such as buoys and ice beacons would be used to track the oil in ice during the winter to facilitate recovery once the ice begins to rot and melt. Response efforts would resume in the late spring as the ice sheet begins to melt and the oil begins to surface through brine channels in the ice sheet and collects in melt pools on the surface of the ice. Response tactics would initially involve ISB of the oil on the melt pools and then resume use of mechanical systems once broken ice conditions allow vessel access. ISB operations may involve helicopter use to assist in the burning of oil in melt pools or oil pockets. During overflow of the rivers, airboats would deploy boom in a u-configuration and conduct ISB operations (Hilcorp, 2015).

In the event of a winter blowout, response methods would be similar to those employed on shore. Instead of using boats and skimmers to mount a response, responders would utilize front-end loaders, bulldozers, vacuum trucks, dump trucks, and front-end mounted ice trimmers to collect and remove the oil-contaminated snow and ice. To facilitate response, ice roads would have to be constructed to adequately support the equipment and maintain safe operating conditions. Another response method includes the use of direct suction in which a vacuum truck with a hose and skimmer head can collect oil from pooled areas such as natural depressions or constructed trenches (Alaska Clean Seas, 2015, ACS technique R-6). Backhoes, amphibious backhoes, and dump trucks are used to mine the ice when trimming of the ice can't be performed. (Hilcorp, 2015). An ice miner can grind oiled ice into a pile which a front-end loader can haul to a dump truck (Alaska Clean Seas, 2015, ACS Tactic R-29). In addition to heavy equipment, response operations would also include the use of snow blowers, shovels, and snow machines/ATVs with sleds to collect and remove the oil. Further, a snow fence can be installed downwind to prevent oiled snow from spreading (Alaska Clean Seas, 2015, ACS Tactic C-19). Manual recovery of lightly oiled snow may involve the use of shovels and brooms. The oiled snow is swept or shoveled into trash cans which are then hauled off by snow machine, loader, or dump truck (Alaska Clean Seas, 2015, ACS Tactic R-2). A high-density polyethylene curtain fabric (plywood or metal can substitute) known as a containment curtain is deployed into an excavated trench in the ice and is used to prevent spreading of oil underneath the ice (Hilcorp, 2015). ISB would also be utilized to remove oil from the ice surface. Propane weed burners are used to ignite smaller oiled areas while hand-held igniters are used on larger oiled areas. Firebreaks are constructed by creating snow berms with front-end loaders or tracked dozers (Hilcorp, 2015) and plowing is used to concentrate oil into piles which can then be ignited and burned (ACS Technique B-5). Trenches in ice can be used to direct oil on the ice surface to a collection point. Through-ice slots can direct oil underneath the ice to a collection point (Alaska Clean Seas, 2015, ACS tactic C-11). ISB can be used at these collection points. Residue from ISB operations are collected and transported to Endicott SDI or North Slope pads (Hilcorp, 2015). A temporary waste staging area would be used to collect waste material from the recovery operations, which saves time otherwise needed for the spill response vehicles to access North Slope roads (Hilcorp, 2015). The waste material would eventually end up at disposal sites.

An oil release to solid ice conditions is easier to respond to because the oil's dispersal in the environment is drastically limited by the snow and ice as compared to a spill on water. Response operations would be determined by the stability of the ice sheet. Prior to significant response efforts ice thickness would need to be measured to determine what and/or if any response equipment and personnel can access the area. As the ice thickness grows, heavier pieces of equipment can be used to recover oil. In an early winter response, initial efforts may be limited to ISB until the ice is capable of supporting responders and equipment. Response operations can continue around the clock with the use of artificial light but the duration of work can be limited by the winter weather conditions. Wind and frigid temperatures negatively affect both equipment and personnel. Winds can reduce visibility to zero by creating blizzard conditions shutting down operations. At -35°F, hydraulic systems become severely impacted and with wind chills between -25°F and -40°F workers take more breaks, reducing the amount of time that response activity occurs. At -40°F all but emergency work stops.

For a large spill it would require in excess of 150 pieces of large equipment such as front-end loaders, dozers, dump trucks, ice trimmers, vacuum trucks, and rolligons to support on-ice recovery. In addition, there would be 50 or more snow machines/ATVs, and snow blowers employed to collect smaller and more remote patches of contaminated oil, snow, and ice. Large scale on-ice operations would occur starting in late December and would continue until ice conditions became unsafe due to melting in mid-June. During the transition period from solid ice to broken ice conditions, ISB would occur using a helicopter and helitorch. Any further response operations would revert to vessel-based systems once the ice sheet fractured creating broken ice conditions. Further, the response tactics can vary depending on the spilled oil's location (on ice, under ice, or within ice), oil's condition, and thickness of the ice (Dickins and Buist, 1999)

The conclusion of the response phase to an incident is based on the ability to continue to recover oil from the environment. When there is no remaining recoverable product, the Federal On Scene Coordinator (FOOSC) will end response operations and efforts will shift to remediation of impacted areas.

4.6.1. Scenario Phases and Impact Producing Factors

This section specifically identifies the manners in which the hypothetical VLOS event described above could impact the environment. The intent of this section is to facilitate thorough yet focused impacts analysis in Section 4.7.

The events constituting the VLOS scenario are first categorized into three distinct phases. These phases, which range from the initial blowout event to long-term recovery, are presented chronologically. Within each phase are one or more components that may cause impacts to the environment. These components are termed "Impact Producing Factors," or IPFs, and will be used in Section 4.7 to guide the environmental impacts analysis. The specific IPFs listed here are intended to inform, rather than limit, the discussion of potential impacts.

Well Control Incident, Offshore Spill and Onshore Contact (Phase 1)

Phase 1 of the hypothetical VLOS scenario comprises the blowout and its immediate consequences. Potential IPFs associated with Phase 1 include the following:

- **Explosion.** Gas released during a blowout could accidentally ignite, causing an explosion or be released into the atmosphere.
- **Fire.** A blowout could result in a fire that will burn until the fire is extinguished or the well is capped.
- **Psychological/Social Distress.** News and images of event could cause various forms of distress.

- **Contact with Oil.** Offshore resources (including resources at surface, water column, and sea floor) could be contacted with spilled oil. Onshore resources could come into direct contact with spilled oil.
- **Contamination.** Pollution stemming from an oil spill may contaminate environmental resources, habitat, and/or food sources.
- **Loss of Access.** The presence of oil could prevent or disrupt access to and use of affected areas.

Spill Response and Cleanup (Phase 2)

Phase 2 of the scenario encompasses spill response and cleanup efforts in offshore Federal and State waters as well as onshore Federal, State of Alaska (SOA), trust, and private lands along the coastline. Potential IPFs associated with Phase 2 include the following and are categorized by season. See Section 4.6 Recovery and Cleanup for further description of responses during all seasons.

Summer Response

- **Vessels.** Vessels could be used in support of spill response and cleanup activities.
- **Skimmers.** Boats equipped to skim oil from the surface.
- **Booming.** Responders could deploy booms—long rolls of oil absorbent materials that float on the surface and corral oil.
- **In-situ burning.** Remedial efforts may include burning of spilled oil. Operations could be monitored by air.

Winter Response

- **Vehicles and Equipment.** Bulldozers, dump trucks, and snow machines could be used on ice roads, frozen ice, or snow for supporting spill response and mechanical recovery.
- **In-situ burning.** Remedial efforts may include burning of spilled oil.

Shoulder Season Response

- **Vessels.** Airboats and workboats could be used in support of spill response and cleanup activities.
- **Vehicles and Equipment.** Hovercraft, trenchers, and all-terrain vehicles could be used in support of spill response and cleanup activities.
- **In-situ burning.** Remedial efforts may include burning of spilled oil. A helicopter could be used to support ISB operations.
- **Skimmers.** Boats equipped to skim oil from the surface.
- **Booming.** Responders could deploy booms—long rolls of oil absorbent materials that float on the surface and corral oil.

All Seasons

- **Animal Rescue.** Animals may be hazed or captured and sent to rehabilitation centers.
- **Drilling of Relief Well.** A drilling rig (either present on LDPI or transported to location in open-water or the frozen ice season) would drill a relief well to control the blowout. The drilling rig cannot be transported during freeze-up or break-up conditions.

Post-Spill, Long-Term Recovery (Phase 3)

Phase 3 of the scenario focuses on the long-term. The exact length of time considered during this Phase would vary by resource. Potential IPFs associated with Phase 3 include the following:

- **Unavailability of environmental resources.** Environmental resources and food sources may become unavailable or more difficult to access or use.
- **Contamination.** Pollution stemming from an oil spill may contaminate environmental resources, habitat, and/or food sources.
- **Perception of contamination.** The perception that resources are contaminated may alter human use and subsistence patterns.
- **Co-opting of human resources.** Funds, manpower, equipment, and other resources required to study long-term impacts and facilitate recovery would curtail availability for other purposes.
- **Psychological/Social Distress.** Distress stemming from a VLOS could continue into the long-term.

4.6.2. Opportunities for Prevention, Intervention, and Response

For the purposes of analysis the discharge is assumed to cease within 90 days of the initial event. The use of 90 days corresponds to the longest time period estimated by the operator for a second drilling rig to arrive on site and complete a relief well. This is a conservative estimate as it does not take into consideration the variety of other methods that would likely be employed to halt the spill within this period such as well intervention, wellhead ignition, and well capping. Some other methods are discussed below and include the estimated time each would take to regain well control.

Potential intervention and response methods are analyzed below as a joint response because their concerted application could substantially decrease the duration, volume, and environmental effects of a spill. These methods are not mutually exclusive; several techniques may be employed if necessary as proposed in the DPP. It may also be possible to apply multiple techniques simultaneously. Again, some of these intervention and response methods could be employed prior to drilling a relief well, and are not factored into the estimated spill duration (of 90 days) as described in the hypothetical VLOS scenario above. The availability and effectiveness of these techniques may vary depending on the nature of the blowout, as well as seasonal considerations. Before discussing loss of well control intervention and response techniques, some of the prevention methods and protocols are discussed that could prevent a kick or blowout that would have otherwise led to a spill.

The primary well control planning and operational protocols Hilcorp will have in place include: selecting the well location to avoid overpressured zones, pore pressure/fracture gradient knowledge, casing design, pressure control equipment and operational monitoring (Hilcorp, 2015). For a detailed description, see Hilcorp (2015, Appendix H).

A primary barrier or tool to preventing a blowout is the column of drilling fluid present in the well during drilling (Wild Well Control, 2010; DNV, 2010). The drilling fluid, with a greater hydrostatic pressure than the pore pressure or formation pressure, keeps the formation fluids from entering the wellbore (DNV, 2010; API, 1987; API, 2010). If formation fluids flow into the wellbore, due to insufficient mud weight as an example, a kick can occur (DNV, 2010; Burgess et al., 1990). Kicks can also occur when drill string is pulled from the hole (tripping). In this case, the drilling mud level drops and thus reduces the hydrostatic pressure if not compensated for by increasing the fluid density before the tripping operation (Burgess et al., 1990; Wild Well Control, 2016a). Further, lost circulation to abnormally low pressured zones or fractured formations can be a precursor to a kick (Burgess et al., 1990). After a kick occurs, if the formation fluid that initially flowed into the wellbore then proceeds to flow to the surface (i.e. the kick is uncontrolled or unrecognized), the kick now becomes a blowout (DNV, 2010; API 1987; Wild Well Control, 2016a).

Secondary barriers to preventing a blowout include the use of blowout preventer equipment (BOP), kill choke lines, wellhead seals, and casing and cement (DNV, 2010), some of which are discussed below.

Natural bridging or plugging could also occur in which a loss of pressure within the wellbore (in the event of a blowout) causes the surrounding formation to cave in, thereby bridging over or plugging the well. While natural bridging or plugging could render certain forms of operator-initiated well control infeasible, it could also impede or block the release of hydrocarbons from the reservoir from reaching the surface. The majority of Gulf OCS blowouts from 1960-1996 were controlled by bridging (either passive or active) (Skalle et al., 1999).

Well Intervention. If a kick or blowout occurred, the original drilling rig would initiate well control procedures. The procedures would vary given the specific situation, but could include:

- **BOP Use.** The use of blowout preventer equipment (both ram and annular types) (Hilcorp, 2015). The rams can seal the wellbore (DNV, 2010) and are distinguished by function including shearing blind rams (which can cut the drill pipe) and blind rams (which can seal an empty wellbore without pipe in the hole) (IADC, 2015). The annular type preventer can prevent movement of the pipe by closing in on the annulus where drilling fluid is moving towards surface, and it can seal the open hole and close in on a variety of sizes of pipe (Rigzone, 2016; Wild Well Control, 2016b).
- **Kill Weight Fluids.** Pumping kill weight fluids into the well to control pressures, once the BOP is closed (Hilcorp, 2015). Hilcorp proposes using the “wait and weight” method, driller’s method, and bullhead to regain well control (Hilcorp, 2015). The wait and weight method uses one circulation to circulate out an influx using mud with an appropriately weighted density (Roy et al., 2007; Burgess et al., 1990). The driller’s method uses two circulations to circulate an influx or kick out of the well (Roy et al., 2007). In the first circulation, the drilling mud (with the original mud weight) circulates the influx out through the annulus while the second circulation is employed if the first circulation was not successful in balancing the pore pressure (Roy et al., 2007; Burgess et al., 1990). The second circulation uses a heavier kill mud than the first circulation and circulates mud from the surface through the drill pipe and out the annulus (Roy et al., 2007; Burgess et al., 1990). The bullheading method involves the use of mud or kill fluid to displace the influx back into the reservoir (API, 2010; Wild Well Control, 2016c)
- **Replace/Repair.** Replacing or repairing any failed equipment to remedy mechanical failures that may have contributed to the loss of well control (such as repairing the existing BOP (Exxon Mobil, 2003))

These techniques cure loss-of-well-control events the vast majority of the time without any oil being spilled.

Well Ignition. Hilcorp proposes the use of well ignition which could combust an estimated 90% of the oil (Hilcorp, 2015). Well ignition reduces the volume and environmental impact of the spill (Conroy et al., 2016; ExxonMobil, 2003). Well ignition works by transferring sufficient energy from a flame to oil droplets within the blowout plume so that the oil (and the methane gas vapor cloud (Hilcorp, 2015)) evaporates and burns (Conroy et al., 2016). The volume, type, and temperature of the oil can affect the amount of energy required to burn it (Conroy et al., 2016). How that energy is transferred from the flame to the oil is influenced by the flame temperature and stability, soot production, water in the oil, blowout flow conditions, oil droplet size distribution, and gas oil ratio (Conroy et al., 2016). Burn efficiency which is determined by dividing the volume of oil burned and evaporated by the total oil spilled (Conroy et al., 2016), can affect the spill volume and environmental impacts because the oil that is not burned can settle on the surrounding area (Conroy et al., 2016). Estimated spill volumes with 85%, 90%, and 95% burn efficiencies for a hypothetical blowout at Liberty are presented by Conroy et al. (2016). For a previous oil and gas development project that had a similar response strategy, ExxonMobil considered the surface intervention of well control that is supplemented by well ignition as the best available technology in its Oil Discharge Prevention and Contingency Plan for the Point Thomson project (ExxonMobil, 2003).

Well Capping is another well control technique that could be used. While the original BOP is used during drilling to prevent a blowout, a capping stack is brought in if the original BOP has failed (Madrid and Matson, 2014). The capping stack includes a separate BOP ram (Madrid and Matson, 2014) and a connector module that connects the capping stack to the wellbore (Wijk, 2014). Capping is the installation of pressure control (or diverter) equipment, known as a capping stack, on the well to regain control of the blowout through post capping kill operations. Post capping kill operations can include direct shut in (BOP or choke shut in blind rams on the BOP are closed or fluid is diverted through a choke and shut in (Abel, 1995), bullheading, or a bullhead top kill operation in which kill mud and cement can be pumped through the capping stack (Wijk, 2014) when the well is on shut-in or diversion (Abel, 1995)., and/or using the volumetric method. The volumetric method bleeds mud from the system to allow for gas expansion (Abel, 1995). The capping stack can shut in and hold pressure on the blowout well using chokes/valves, and it can also provide for further wellbore intervention (Chen et al., 2013). The soft shut in method refers to the chokes progressively limiting the flow (Madrid and Matson, 2014). The capping stack valves can also close and prevent the flow of oil (Chen et al., 2013). Hilcorp states that the most likely method to stop the blowout after failure of the BOP is well capping and is also a primary mechanism for controlling on-land losses of well control (Hilcorp, 2015). Hilcorp estimates the time to attain well control through the use of well capping is 10 to 20 days based on case studies (Hilcorp, 2015, Section 14). Hilcorp considers the use of well capping and relief well drilling the best available and safest technology (BAST) (Hilcorp, 2015). Before capping could take place, the blow out well rig would be moved off the wellhead to allow access for installation of the capping stack. If the rig moving system is disabled, then bull dozer, block and tackle and/or crane would be used (Hilcorp, 2015).

Relief Well. A relief well is drilled after surface intervention methods have failed (Harvey, 2014). After a relief rig has drilled a relief well down to the appropriate subsurface location to intercept the wellbore of the blowout well, kill fluid is then pumped from the relief well to the blowout well to regain well control (Flores et al., 2014; Wild Well Control, 2010). Typical planning guidelines for drilling a relief well include: 1) identifying a surface location that avoids shallow hazards and faults and considers locations of neighboring well bores; 2) analyzing the relief well drilling feasibility by reviewing the well design and kill modeling (kill modeling may include the estimation of hole size needed at target well intercept point, pump rates, and mud volumes (Wild Well Control, 2010)); and 3) determining the well trajectory that could track the blow-out well bore and intercept it at the casing shoe above reservoir depth (Halliburton, 2014).

To drill the relief well, the operator proposes using either a company-owned rig or a contract rig. The company-owned rig would be onsite and pre-positioned at the specified relief well surface location on the LDPI while the contracted rig would be mobilized to the LDPI (Hilcorp, 2015, Appendix H). After broken into modules, the relief rig under contract could be mobilized by barge in open water or on ice road during the winter. If either of these forms of transport aren't available (i.e., if the ice is not thick enough for travel or if the ice concentration is too high during breakup), then the rig would be staged at the closest location to the start of the transport route until conditions are feasible for mobilizing. The total mobilization time for the relief rig is estimated to be 10 to 30 days (Hilcorp, 2015).

As previously mentioned, the availability and/or effectiveness of certain response and intervention techniques can depend on the type of the blowout and time. Three major distinctions with respect to the specific discharge point of a blowout factor into decisions about responses. Possible discharge paths include: 1) at the LDPI surface (and the rig is not destroyed) through leak paths on the BOP or wellhead; 2) below the LDPI/seafloor, outside the wellbore; 3) at the LDPI surface (and the rig is destroyed). Opportunities for operational intervention and response vary in each of these circumstances.

Seasonal Drilling Restriction Mitigation Measure

As discussed in Chapter 2, BOEM received several comments which proposed seasonal restrictions on drilling into hydrocarbon zones as a means to reduce the likelihood of a large or very large oil spill contacting the Beaufort Sea and adjacent coastal areas during broken ice or open water conditions.

BOEM considered the following in developing a seasonal drilling restriction:

- Historical applications of seasonal drilling restrictions in State of Alaska offshore waters
- Estimated maximum oil spill volumes from Beaufort Sea gravel islands
- Reservoirs accessed from Beaufort Sea gravel islands
- Ice conditions in Foggy Island Bay
- The frequency of well control events during analogous drilling activities
- The recoverability of oil in ice

BOEM found that the State of Alaska has imposed, or the operator as chosen to adopt, seasonal drilling restrictions on Northstar Island, Oooguruk Island and Spy Island (Nikaichuq) in the Beaufort Sea.

To determine a reasonable reservoir drilling season, BOEM analyzed fall and spring ice conditions of Foggy Island Bay using mooring data and considered information provided in the Liberty EIA. HAK informed BOEM that confining reservoir drilling to late October through June 1st would only increase the drilling timeline by 3-5 months; this is within the scope of the 5 year construction and drilling schedule already presented in the DPP and analyzed in this DEIS, and was not determined to be a burdensome operational increase by BOEM or HAK.

Using information from three reports - *Loss of Well Control Occurrence and Size Estimators* (Holand et al, 2015), *Oil Spill Occurrence Rates for Alaska North Slope Crude and Refined Oil Spills* (Robertson et al, 2013) and *Oil Spills in the U.S. Arctic Marine Environment* (NRC, 2014) – BOEM determined that uncontrolled surface blowouts that cause “major” pollution are unlikely; oil spills (no matter the source from the facility and associated infrastructure) are typically small (<10 bbl); and oil spills are more easily contained and recovered in ice conditions (also discussed in Section 4.5).

From this analysis, BOEM determined that a reasonable proposed mitigation measure would:

- Confine reservoir drilling to those times when both (1) at least 18” of ice exists in all areas within 500’ of the LDPI, and (2) such ice has not been appreciably weakened by spring overflooding. The period of time during which reservoir drilling would be allowed typically starts approximately October 21st and ends approximately June 1.
- Define “reservoir drilling” as any drilling (whether for development, workovers, or completion) targeting the Kekituk Zone 2 formation which occurs either beyond the last casing interval above the reservoir or within 500 ft of the reservoir; and
- Allow for non-reservoir drilling and all other operations year-round (subject to the temporary annual suspension proposed in HAK’s DPP to avoid interference with subsistence hunting).

4.7. Effects of a Very Large Oil Spill (VLOS)

4.7.1. Effects of a VLOS on Water Quality

This section assesses the potential water quality effects in the proposed action area from a VLOS from the LDPI. The volume of the VLOS assumed in this analysis is 4,610,000 bbl. Section 4.5 describes the hypothetical VLOS scenario. Section 4.5.3 describes the fate and behavior of the spill. Section 4.6 summarizes oil-spill recovery and clean-up. Section 4.6.2 discusses opportunities for prevention, intervention, and response for a VLOS from the Proposed Action.

Hydrocarbon concentrations in water have been measured in various major oil spills around the world. Four months into the Ixtoc release (Gulf of Mexico, 1979–1980 at approximately 50 m (164 ft) water depth), liquid hydrocarbons in the spill plume measured >10 ppm within 8 km (5 mi) of the release, 0.02 ppm at 24 km (15 mi) from the release, and <0.005 ppm at 40 km (25 mi) from the release (Boehm et al., 1982). Dispersant, Corexit 9527, had been applied to surface waters via aerial application to disperse oil in the region of the Ixtoc spill. Similarly, relative decreases were found for specific toxic compounds such as benzene and toluene (NRC, 1985).

At the Ekofisk Bravo release in the North Sea (1977, surface spill) concentrations of volatile liquid hydrocarbons (present mostly as an oil-in-water emulsion) ranged up to 0.35 ppm within 19 km (12 mi) of the site, starting 1.5 days into the 7.5 day release (Grahl-Nielsen, 1978). Lesser amounts of oil (<0.02 ppm) were detectable in some samples at 56 km (35 mi) from the site, but not at 89 km (55 mi).

In restricted waters during flat calm, a test spill during the Baffin Island Oil-spill Project resulted in maximum hydrocarbon concentrations in the water column of 1–3 ppm (Green, Humphrey, and Fowler, 1982). These concentrations were reached within 2 hours of the spill and persisted through 24 hours. No oil was detected deeper than 3 m (9.8 ft), and the most oil and highest concentrations were in the top 1 m (Mackay and Wells, 1983).

The *Deepwater Horizon* (DWH) Oil Spill was a seafloor release in deep water in the Gulf of Mexico. Several subsurface studies were conducted in the months following the DWH Oil Spill (e.g., Camilli et al., 2010; Joye et al., 2011; Yvon-Lewis, Hu, and Kessler, 2011; Kessler et al., 2011; Valentine et al., 2010; Hazen et al., 2010; Kujawinski et al., 2011). These studies focused on the distribution, extent, concentration, composition, and degradation of the DWH Oil Spill oil at depth and over time.

The conditions in the waters at the DWH Oil Spill site differ markedly from the conditions present at the Proposed Action Area. The DWH Oil Spill release occurred in at a depth of 1,500 m (4,921 ft); the proposed action is to drill from the surface of a gravel island in 5.8 m (19 ft) of water. Oil from the hypothetical VLOS would enter the marine environment from the sea surface. This depth difference is important given how gas and liquids behave differently at various pressures, with more gas staying in solution at greater depths. A greater depth may also present a greater likelihood that distinct density layers and currents that could entrain and transport hydrocarbons. Differences between the Gulf of Mexico and the Beaufort Sea in seasonality, weather and wind patterns, sea ice, and surface water temperatures also make extrapolations from the *Deepwater Horizon* Oil Spill release and a hypothetical release in the Beaufort Sea problematic.

Water temperatures in the shallow Beaufort Sea are similar to the temperatures in the deepwater Gulf of Mexico, suggesting the Beaufort Sea could support similar levels of hydrocarbon (including methane) degradation. Both methane and petroleum hydrocarbon degraders are present and active in the ice, water, and sediment in the Arctic Ocean in general (Gerdes et al., 2005; Damm et al., 2007; Atlas, Horowitz, and Busdosh, 1978; Braddock, Gannon, and Rasley, 2004

The following subsections describe the types of effects that could occur during each Phase of the VLOS scenario.

4.7.1.1. Phase 1 (Well Control Incident, Offshore Spill, and Onshore Contact)

Well Control Incident

The initial release event could impact water quality via the release of natural gas. When natural gas (primarily methane) is released into the water, it rises through the water column as a function of pressure and temperature. The quality of the water would be altered temporarily as some of the natural gas enters the water as a water-soluble fraction. Upon reaching the surface the gaseous

methane would react with air, forming water and carbon dioxide (CO₂), which would then disperse into the atmosphere. The near-surface water quality would have higher concentrations of CO₂ than is natural and could therefore affect processes and reactions in the microlayer at the water-air interface, such as egg and larvae respiration (GESAMP, 1995).

Offshore Spill

The general weathering processes and behavior of oil in Arctic ice-free waters may include spreading, fragmentation into smaller-sized slicks, evaporation, dispersion, emulsification, oxidation, sedimentation, biodegradation, and dissolution (Lee et al., 2011). In cold water or when ice is present, the weathering of oil can be slower or non-influential (TRB and NRC, 2014). During freeze up, specific weathering processes that can affect oil are evaporation, dissolution, emulsification, and dispersion (TRB and NRC, 2014). The fate and behavior of oil spilled under ice may include spreading, evaporation, dispersion, emulsification or biodegradation and these processes can be slower or non-influential (Lee et al., 2015).

Horizontal transport takes place via spreading, advection, dispersion, and entrainment while vertical transport takes place via dispersion, entrainment, Langmuir circulation, sinking, overwashing, partitioning, and sedimentation (USDOI, MMS, 2007b, Appendix A, Figure A.1-1 Fate of Oils Spills in the Ocean during Arctic Summer, and Figure A-2. Fate of Oil Spills in the Ocean during Arctic Winter). The persistence of an oil slick is influenced by the effectiveness of oil-spill response efforts and affects the resources needed for oil recovery (Davis et al., 2004). The persistence of an oil slick may also affect the severity of environmental impacts as a result of the spilled oil.

Key weathering processes that may be relevant to the persistence of an oil spill in an Arctic marine environment are discussed in Section 4.5.3.

Oil moves through the water in horizontal and vertical directions. This movement of oil occurs through several processes including spreading, dispersion, advection (tides, current, Langmuir circulation), entrainment, deposition to seafloor sediments, re-suspension from seafloor, uptake and excretion by biota, and stranding on shorelines. Waves and winds can mix oil droplets on the surface into subsurface waters. The various mechanisms by which oil moves in seawater are also influenced by the type and degree of sea ice present and the location of the spilled oil (on the water, under the ice, encapsulated in the ice or on top of the ice).

The more volatile compounds in an oil slick, particularly aromatic volatiles, are usually the most toxic components of an oil spill. In-situ, cold-water measurements (Paine and Levin, 1981; Payne et al., 1984) have demonstrated that concentrations of individual components in an oil slick decrease substantially over a period of hours to tens of days.

The highest dissolution rates of aromatics from a slick occur in the first few hours of a spill and accumulate in the underlying water (Paine and Levin, 1981). By the time dissolved oil reaches depths of 10 m (33 ft) in the water column, it becomes diluted and may spread horizontally over about 10,000 m (6.2 mi). The slick would become patchy, with the total area—containing widely separated patches of oil—stretching orders of magnitude larger than the actual amount of surface area covered by oil.

A small portion of the oil from a surface spill would be deposited in the sediments in the immediate vicinity of the spill or along the pathway of the slick. The observed range in deposition of oil in bottom sediments following offshore spills is 0.1-8% of the slick mass (Jarvela, Thorsteinson, and Pelto, 1984). Generally, the higher percentage of deposition occurs in spills nearshore where surf, tidal cycles, and other inshore processes can mix oil into the bottom (Manen and Pelto, 1984).

An offshore spill could create tarballs. Slow photo-oxidation and biological degradation would slowly decrease the residual amount of oil. During the slow process of sinking, sunken tarballs would be

widely dispersed in the sediments, resulting in widespread distribution but relatively lower concentrations in any one area of sediment.

Decomposition and weathering processes for oil are much slower in cold waters than in temperate regions. Prudhoe Bay crude remained toxic to zooplankton in freshwater ponds for 7 years after an experimental spill, demonstrating persistence of toxic-oil fractions or their weathered and decomposition products (Barsdate et al., 1980). In marine waters, advection and dispersion would reduce the effect of release of toxic oil fractions or their toxic degradation products, including products resulting from photo-oxidation. Isolated waters of embayments, shallow waters under thick ice, or a fresh spill in rapidly freezing ice, however, would not be exposed to this advection and dispersion.

An oil spill that occurs in broken-ice or under pack ice during the deep Arctic winter would freeze into the ice, move with the ice and melt out of the ice the following summer. Spills in first-year ice would melt out in late spring or early summer. Spills in multiyear ice would melt out later in the summer or in subsequent summers. Spills released from the ice would be relatively unweathered and would have the characteristics of fresh oil. Before the oil was released from the ice, the contaminated ice could drift for hundreds of kilometers.

Onshore Contact

Oil that contacts the shoreline can be mixed into the nearshore and beach sediments then remobilized and dispersed, causing persistent elevation of hydrocarbon concentrations in nearshore waters. Impacted habitats could include estuaries, embayments, river deltas and other shoreline environments. Phase 2 (Spill Response and Cleanup).

4.7.1.2. Phase 2 (Spill Response and Cleanup)

Dispersants

Dispersants are a combination of surfactants and solvents that work to break surface oil into smaller droplets which then disperse on the surface and into the water column. Many factors affect the behavior, efficacy, and toxicity of a particular dispersant, including water temperature, surface salinity, wave and wind energy, light regime, water depth, type of oil, concentration of dispersant, how the dispersant is applied (constant or intermittent spikes), and exposure time to organisms. Dispersants are used to degrade an oil spill more quickly through increasing surface area and to curtail oil slicks from reaching shorelines (Word, Pinza, and Gardiner, 2008).

As oil breaks into smaller droplets it can distribute vertically in the water column. If oil droplets adhere to sediment, the oil can be transported to the seafloor and interstitial water in the sediment. In shallow nearshore waters, wind, wave and current action would more likely mix the dispersant-oil mixture into the water column and down to the seafloor environment. The water toxicity effects of dispersant application in the event of a VLOS would be similar to the effects outlined above under Phase 1. Chemically dispersed oil is thought to be more toxic to water column organisms than physically dispersed oil, but the difference is not clear-cut, and generally the toxicity is within the same order of magnitude (NRC, 2005). Recent papers also show that some dispersants can inhibit or leave unaffected biodegradation of oil in the water column, while others noted accelerated biodegradation (Fingas, 2014).

In-Situ Burning

In-situ burning is used to reduce an oil spill more quickly and to curtail oil slicks from reaching shorelines. In-situ burning could increase the surface water temperature in the immediate area, and produce residues. The upper-most layer of water (upper millimeter or less) that interfaces with the air is referred to as the microlayer. Important chemical, physical and biological processes take place in this layer and it serves as habitat for many sensitive life stages and microorganisms (GESAMP,

1995). Disturbance to this layer through temperature elevation could cause negative effects on biological, chemical, and physical processes.

Residues from in-situ burning can float or sink depending on the temperature and age of the residue. Floating residue can be collected; however, residues that sink could expose the benthic waters and sediment to oil components as the residue degrades on the seafloor.

The NOAA Office of Response and Restoration states, “Overall, these impacts [from open-water in-situ burning] would be expected to be much less severe than those resulting from exposure to a large, uncontained oil spill” (NOAA, 2011). If an oil spill occurred in winter, in-situ burning would be limited by the lack of open water to collect oil and open water in which to burn it. If burning could occur in winter on a limited scale, sea ice would melt in the immediate vicinity of the burn.

Offshore Vessels and Skimmers

Mechanical recovery of oil would result in more vessel traffic and potential impacts to water quality from potential deck drainage, sanitary and domestic discharges, brine and cooling water discharges, small spills, anchoring in benthic habitat, disturbance of microlayer and potential for introduction of invasive species from foreign or out-of-state vessels. In winter, icebreakers could affect the movement of spilled oil that may be trapped beneath or in the ice. Vessel discharges are permitted by USEPA under the Vessel General Permit.

Drilling of Relief Well

A drilling rig (either present on island or transported to location in open-water or the frozen ice season) would drill a relief well to control the blowout. Muds and cuttings from drilling a relief well would be disposed of in the waste well or discharged per EPA NPDES permit. There is potential for accidental spills and potential for introduction of invasive species from vessel traffic while drilling a relief well.

Beach Cleaning and Booming

The cleaning of oiled beaches (and booming and rescue of oiled animals) could entail small boat and aircraft landings on marine and freshwater shorelines and waters; large numbers of people walking and wading through aquatic habitats; collection of oiled sediment and beach wrack; possible booming of coastal waterways; possible hydraulic washing with hot water; possible application of fertilizer to enhance degradation of oil; and possible raking of fine sediments.

These activities could result in effects from suspended sediment in waters and resettlement of sediments elsewhere, possible resuspension of hydrocarbons, runoff of treatment-laden waters that could affect nearshore temperature and nutrient concentrations, removal of beach wrack nutrient sources from intertidal zones, and potential for introduction of invasive species from small boats, waders, and clothing worn by workers from outside of the Alaska Arctic region.

4.7.1.3. Phase 3 (Post-Spill, Long-Term Recovery)

During long-term recovery, there could be reoccurring visitation by monitoring and research personnel, which could result in similar impacts encountered during beach cleaning.

Over the long-term, contamination of aquatic environments would continue from oil leaching from sediments and oil resuspended, including resuspension of Polycyclic Aromatic Hydrocarbons (PAHs). Dispersant residue on the seafloor could also leach into the water. Sunlight (UV radiation) increases the toxicity of leached PAHs, so summer sunlight in Arctic Alaska could exacerbate the amount and degree of toxicity.

4.7.1.4. Oil Spill Trajectory Analysis

Appendix A presents the Oil-Spill Risk Analysis (OSRA) completed for this Proposed Action. Section A-1 presents the assumptions about sizes, sources, and oil-type for this large oil spill (greater than or equal to 1,000 bbl) analysis. Table A-1 shows the general size categories, source of spill(s), type of oil, size of spill(s) in bbl, and the total volume BOEM assumes in the analysis of oil-spill effects. Section A-2 discusses the behavior and fate of oil spills. Sections A-3 and A-4 discuss the components and inputs to this OSRA analysis. For this analysis, the coastline was analyzed by dividing the Chukchi (United States and Russia) and Beaufort (United States and Canada) seas coastline into 146 LSs.

For purposes of this analysis, BOEM assumes that one spill occurs from the LDPI or along the offshore pipeline. BOEM uses the median spill sizes for OCS pipelines and platforms, rounded to the nearest hundred, as the likely large spill sizes for an offshore pipeline leak and LDPI spill in the proposed action (Table 4.7.1-1). The large OCS offshore pipeline spill size due to a rupture is based on the operator's estimate of a worst-case discharge from its pipeline, rounded to the nearest hundred.

Table 4.7.1-1. Spill sizes by Type for Trajectory Analysis.

OCS Offshore Pipeline Leak	OCS Offshore Pipeline Rupture	OCS Island Spill
1,700 bbl	5,000 bbl	5,100 bbl

This analysis assumes a spill in summer reaches the sea surface. It is assumed that a spill during winter would persist for up to 360 days if it is encapsulated in ice and melts out.

Physical oceanography, meteorology, and weathering processes determine the oil's fate in the environment. Weathering alters the chemical and physical characteristics and toxicity of spilled oil. The major oil weathering processes are spreading, evaporation, dispersion, dissolution, emulsification, microbial degradation, photochemical oxidation, and sedimentation to the seafloor or stranding on the shoreline (Payne et al., 1987; Boehm, 1987; Lehr, 2001).

Appendix A, Table A.1-3 presents the fate and behavior of a 5,100 bbl crude oil spill from the LDPI. The table provides the percentages of oil remaining, dispersed, and evaporated for a summer spill and a meltout spill at 1, 3, 10, and 30 days. For a summer spill at 30 days, 26.7% of the crude oil remains, 56.1% is dispersed and 17.2% has evaporated, and 80.16 km of coastline is oiled. For a meltout spill at 30 days, 80.2% of the crude oil remains, 3.3% is dispersed and 16.5% has evaporated, and 75.31 km of coastline is oiled.

Appendix A, Table A.1-4 presents the fate and behavior of a 5,000 bbl crude oil spill from pipeline rupture. For a summer spill at 30 days, 26.7% of the crude oil remains, 56.1% is dispersed and 17.2% has evaporated, and 79.41 km of coastline is oiled. For a meltout spill at 30 days, 80.2% of the crude oil remains, 3.3% is dispersed and 16.5% has evaporated, and 74.61 km of coastline is oiled.

Appendix A, Table A.1-5 presents the fate and behavior of a 1,700 bbl crude oil spill from a pipeline leak. For a summer spill at 30 days, 26.4% of the crude oil remains, 56.3% is dispersed and 17.3% has evaporated, and 47.74 km of coastline is oiled. For a meltout spill at 30 days, 80.2% of the crude oil remains, 3.3% is dispersed and 16.5% has evaporated, and 44.85 km of coastline is oiled.

The chance of a large spill from operations during the Proposed Action contacting shoreline sections or ERAs is taken from the oil-spill-trajectory model results, called conditional probabilities. These are summarized in Section 4.1.2.2 of the DEIS and are listed in Appendix A, Tables A.2-1 through A.2-54. Probabilities presented below are conditional probabilities estimated by the OSRA model (expressed as percent chance) of a spill $\geq 1,000$ bbl in size contacting the specified ERAs within the days and seasons indicated.

The coast and barrier islands near the proposed action are vulnerable to contact by a crude oil spill in May through October.

Contact with the nearby coast could have adverse effects on the quality of coastal waters. Coastal waters could exceed background concentrations of hydrocarbons over a long period (years) if crude oil contacts the shoreline and becomes entrained in the coastal sediments. The waters and coastline adjacent to the proposed action area are the Sagavanirktok River Delta/Foggy Islands Bay (ERA 77), Mikkelsen Bay (ERA 78), and Sagavanirktok River Delta (ERA 85). The excerpts below from Appendix A, Tables A.2-1 through A.2-6 represent annual conditional probabilities (expressed as percent chance) that a large oil spill starting at Liberty Island (LI) or along the proposed pipeline route (PL) would contact the closest land areas and coastal waters within the period of days indicated.

A VLOS would severely affect marine water quality locally for several days by increasing the concentration of hydrocarbons in the water column to levels that greatly exceed background concentrations. Beyond the local area, water quality would be moderately affected. Regional (more than 1,000 sq km [386 sq mi]), long-term (more than 1 year) degradation of water quality to levels above State and Federal criteria because of hydrocarbon contamination is unlikely. Contact with the barrier islands could allow an oil spill to pass through to the Beaufort Sea. The barrier islands closest to the proposed action area are Stockton Islands/McClure Islands (ERA 9); Midway, Cross, and Bartlett Islands (ERA 96); and Tigvariak Island (ERA 97). The excerpts from Appendix A, Tables A.2-1 through A.2-6 represent annual conditional probabilities (expressed as percent chance) that a large oil spill starting at the proposed LDPI (LI) or along the proposed pipeline route (PL) would contact the closest barrier islands and reach the Beaufort Sea within the period of days indicated:

4.7.1.5. Conclusion

A VLOS of 4,610,000 bbl of oil released over 90 days could severely affect water quality locally for months to years by increasing the concentration of hydrocarbons in the water column to levels that greatly exceed background concentrations. A VLOS would present sustained degradation of water quality from hydrocarbon contamination that would exceed State of Alaska (SOA) and Federal water quality criteria. Additional major effects on water quality could occur from response and cleanup vessels, in-situ burning of oil, dispersant use, and activities on shorelines associated with cleanup, booming, beach cleaning, and monitoring. The potential impacts of a VLOS on water quality are therefore deemed to be moderate to major.

4.7.2. Effects of a VLOS on Air Quality

A VLOS event, initiated by a hypothetical blowout, would release potentially harmful emissions into the atmosphere, particularly those pollutants regulated under the Clean Air Act (CAA). Pollutants regulated under the CAA include nitrogen dioxide (NO₂), carbon monoxide (CO), sulfur dioxide (SO₂), particulate matter (PM₁₀ and PM_{2.5}), and volatile organic compounds (VOC). Following the initial well control incident, emissions would occur during each phase of the event due to fires (including in-situ burning), evaporative emissions from the oil, and emissions from sources operating during the oil spill recovery and cleanup process. The behavior of emissions released into the atmosphere over the Beaufort Sea, should a VLOS occur there, would be influenced by the Arctic climate as well as the severity of the oil spill and the characteristics of the pollutant sources. The Arctic climate is highly variable by season, is influenced by the polar maritime characteristics of the Arctic Ocean, and reflects the polar continental characteristics of the large adjacent Alaskan land mass. Meteorological conditions, such as temperature inversions, wind, and precipitation, define the atmospheric stability of the area and dictate the amount of turbulence and mixing that can occur. Thus, these parameters affect the buildup of emissions and concentration of harmful pollutants that could threaten human health and wildlife. Therefore, the severity of impacts to air quality from a VLOS would depend largely on whether the spill occurs in the winter or in the summer. As explained in the following subsections, an oil spill or oil-spill recovery occurring during the winter would likely result in greater impacts to air quality than a spill occurring during the summer.

4.7.2.1. Phase 1 (Well Control, Offshore Spill and Onshore Contact)

A loss of well control resulting in flames would result in a large black smoke plume containing PM and the other products of combustion, such as NO_x, SO₂, CO, VOC, and CO₂. The fire could also produce Polycyclic Aromatic Hydrocarbons (PAHs), which are known to be hazardous to human health. In particular, the intense heat of the fire would elevate the level of NO_x emissions, and concentration of PM in the initial smoke plume would have the potential to temporarily degrade visibility in the immediate area and in any affected area designated as a Prevention of Significant Deterioration (PSD) Class II area and other areas where visibility is of significant value. It would be during this initial event when the majority accumulation of BC would occur. The deposits would be more severe if the initial explosion were to occur in the winter when the maximum amount of sea ice and land ice and snow are present.

The heat of the fire would immediately cause the pollutants within the plume to disperse in an upward buoyant flow. The location of high pollutant concentrations due to the smoke depends on the stability of the atmosphere at the time of the explosion. Should the VLOS occur during winter months, the upward transport of the pollutants could be constrained by fumigation conditions limiting dilution with the surrounding air, and restricting transport by wind. In this case, pollutant concentration levels at nearby locations would likely reach levels that exceed the Federal and State of Alaska (SOA) thresholds that define impacts as significant. Otherwise, the rising plume of pollutants would become increasingly diluted with height and surface concentration levels would not be as high in the immediate vicinity of the fire (Evans et al., 1991). In either case, over time the smoke would be transported by the wind and would eventually affect surface areas at a distance from the fire.

Emissions of VOC would be high during Phase 1 due to evaporation of freshly surfaced oil. A laboratory analysis of oil spilled during the *Deepwater Horizon* (DWH) event showed the first 23% of the oil evaporated within the first two hours following the initial explosion. During this time, the emissions of VOC were confined to a relatively narrow plume as the sea surface transport of oil did not exceed a few km (de Gouw, Middlebrook, Warneke, Ahmadov, Atlas et al., 2011). Consequently, the VOC impacts would be most severe immediately following the explosion and decrease as the oil slick spreads. With increasing distance from the location of the fire, some of the gaseous pollutants, particularly VOC, would undergo chemical reactions resulting in the formation of secondary organic aerosols, which are mostly semi-volatile organic material.

Computer modeling conducted to evaluate emissions from a large oil spill considered several different VOC and other compounds, including benzene, ethylbenzene, toluene, and o-xylenes, which are classified by the EPA as hazardous air pollutants (HAP). The results showed that these compounds vaporize almost completely within a few hours following a spill. The ambient concentrations would peak within the first several hours after a spill and would be reduced by two orders of magnitude after about 12 hours. The heavier compounds would take longer to vaporize and may not peak until about 24 hours after spill occurrence. Additional information of air quality impacts from oil spills is included in the 2007 Lease Sale 193 Final EIS (Sections IV.C.1.b; IV.C.2.b; and IV.C.3.b) (USDOJ, MMS, 2007b).

Offshore Spill

Impacts from this phase of the VLOS would continue until the sea is clear of all or most of the oil. As long as there is an oil slick on the sea surface there will be evaporative emissions and some level of air quality degradation until nearly all volatile hydrocarbons are depleted from the oil. As such, impacts from this phase would occur simultaneously and in combination with the impacts occurring during Phase 2 and 3.

Evaporation contributes to weathering of the oil, the natural chemical and physical processes that lead to the disappearance of oil from the sea surface. However, the rate of evaporation differs depending

on volatility of the oil and increases with higher temperatures. Higher temperatures also allow an oil slick to spread more quickly, thinning out the layer of oil, and decreasing the emissions of VOC. Evaporation decreases the oil's toxicity because the lighter more toxic hydrocarbons dissipate. Fifteen to 30% of the oil could evaporate within the first 30 days, depending on the season (Polar Research Board, 2003).

During the *Deepwater Horizon* event, air samples were collected through the inter-agency efforts of British Petroleum (BP), Occupational Safety and Health Administration (OSHA), and the U.S. Coast Guard. The samples showed concentration levels of HAPs, such as benzene, toluene, ethyl benzene, and xylene to be below the OSHA Occupational Permissible Exposure Limits (PEL) and the more stringent ACGIH (American Conference of Governmental Industrial Hygienists®) Threshold Limit Values® (TLVs) (U.S. Department of Labor, 2010). However, even in low concentrations, some HAPs emissions may be hazardous to personnel working in the vicinity of the spill site, which could be reduced by monitoring and using protective gear, including respirators.

Concentrations of pollutants depend largely on the volume of the oil over the sea surface and the type of oil that was spilled. As a general rule, emissions of VOC would be highest at the source of the spill because the rate of evaporation is influenced by the volume of oil present at the surface. However, with time the emissions would decrease because even if the oil were not recovered, VOC concentrations would decrease as the surface oil area increases and gets thinner through transport by the current. This phase of the VLOS could continue for weeks so that emissions would eventually disperse in the wind even allowing for frequent temperature inversions during winter when winds are very light. Average wind speeds over the Arctic are sufficient to disperse the evaporated pollutants over such a long period of time. Air quality impacts could be major in the areas where oil is thick over the sea surface, which would likely be at the beginning of Phase 2 and could occur during a winter VLOS. However, minor to moderate levels of effect to air quality are expected as time goes by and the oil volume decreases.

Onshore Contact

As the spill nears shore, evaporative emissions from the sea surface oil slick would continue to occur as described above. As such, a portion of the most volatile hydrocarbons would have evaporated by the time the oil reaches the shoreline. Therefore, potential for harmful VOC emissions would depend on the remaining volatility of the oil and the volume of oil accumulating on the shore. Combined with the other effects of weathering, such as dissolution and dispersion, further harmful emissions from the oil would likely be limited.

Once the oil is onshore, even minor emissions could cause short-term effects to human health. The emissions may cause temporary eye, nose, or throat irritation, nausea, or headaches, but the doses are not thought to be high enough to cause long-term harm (U.S. Environmental Protection Agency, 2010). Conversely, responders could be exposed to levels higher than the permissible exposure levels (PEL) established under the OSHA guidelines (U.S. Department of Labor, 2010). During the *Deepwater Horizon* event, 15,000 air samples collected near shore by BP, OSHA, and the U.S. Coast Guard (USCG) showed most levels of benzene, toluene, ethylbenzene, and xylene were under detection levels. Among the many samples taken by BP, there was only one indicating benzene exceeded the OSHA PEL (USDOJ, BOEMRE, 2011a, Appendix B). All other sample concentrations were below the more stringent ACGIH® TLVs (U.S. Department of Labor, 2010). All measured concentrations of toluene, ethylbenzene, and xylene were within the OSHA PELs and ACGIH TLVs.

The VOC emissions from oil collecting onshore would cause a negligible to minor impact to air quality that is short-term and not expected to cause permanent harm. However, responders are at risk for exposure to harmful levels of benzene and should take safety precautions to avoid exposure.

4.7.2.2. Phase 2 (Spill Response and Cleanup)

The sheer volume of petroleum estimated for release during a VLOS would require an array of spill response and cleanup techniques and strategies. No longer concerned primarily with VOC emissions, efforts during this phase of the VLOS event would engage new sources of emissions, such as dispersants, in-situ burning, and the use of offshore vessels. To support these efforts requires the use of aircraft and surface vehicles, which also produce potentially harmful emissions.

Dispersants

The use of dispersants and in-situ burning are the two non-mechanical techniques used most commonly in response to an oil spill. Dispersants and in-situ burning focus on changing the characteristics of the oil within the environment rather than using mechanical equipment (physical containment and recovery equipment, such as booms and skimmers) to recover or remove the oil (Ocean Studies Board, 2005). Dispersants, which may be applied by marine vessels or by aircraft, are chemical agents, such as surfactants, solvents, and other compounds, that break up the oil slick by decreasing interfacial tension between water and oil. The result is small oil droplets that will not merge with other oil droplets. The droplets stay suspended in the water column and are transported by waves. The objective of using a dispersant is to transfer oil from the sea surface into the water column (Ocean Studies Board, 2005). While the use of dispersants can decrease the size of the oil slick, toxic emissions are possible from the chemicals and solvents used in dispersants that could be potentially harmful. Following the DWH event, the EPA mobilized the Trace Atmospheric Gas Analyzer (TAGA) buses that are self-contained mobile laboratories that conduct air quality monitoring (EPA, 2015). The EPA conducted monitoring for two chemicals in dispersants that have the greatest potential for air quality impacts: EGBE (2 butoxyethanol) and dipropylene glycol monobutyl ether. The TAGA analysis detected levels of these chemicals in the air along the Gulf Coast that were below the threshold that would likely cause health effects. Consequently, EPA suggests that using dispersants for oil-spill cleanup would cause a negligible impact on air quality (EPA, 2015).

In-situ Burning

In-situ burning (ISB) is controlled burning of oil intended to decrease the volume of sea surface oil after an oil spill. The burning of the oil results in emissions of NO_x, SO₂, CO, VOC, and CO₂ within a plume of black smoke. Monitoring studies of controlled oil burning at sea showed levels of NO_x, SO₂, and CO were below detection levels (Fingas, Ackerman, Lambert et al., 1995). The study found that VOC emissions were below levels detected from the unburned oil and PAHs were not at a level considered harmful. Results of smoke-plume modeling showed concentrations of PM did not exceed the health criterion of 150 mg/m³ when measured three miles downwind of the burning (USDOI, BOEMRE, 2011a). Considering the low concentrations of pollutants found in monitoring and modeling, and the short-term nature of in-situ burning, there would be a minor impact to air quality. Additional information concerning air quality impacts from in-situ burning is included in the 2007 FEIS (Sections IV.C.1.b; IV.C.2.b; and IV.C.3.b) (USDOI, MMS, 2007a).

Offshore Vessels

Offshore vessels would be used to remove oil from a spill at sea, apply dispersants during open-water periods and during parts of break-up and freeze-up periods. The oil-skimming vessels use devices to skim oil off the surface of the water, such as belts, disks, tubes, and suction devices. A VLOS may require up to a hundred or more diesel-powered oil-skimming vessels, and other marine equipment such as icebreakers, over the course of time required confining and removing such a large amount of oil from the surface. It is a time-consuming process that would likely take weeks or months to complete and would result in thousands of tons of emissions, particularly NO_x, but also including CO, PM, SO₂, VOC, and CO₂ (Discovery News, 2010; EPA, 1996). Emissions from this number of vessels would likely result in temporary major levels of effect to air quality.

Aircraft and Surface Vehicles

A portion of dispersants used to decrease the size of the oil slick may be applied using aircraft. During the response and cleanup process other aircraft may be needed for personnel and equipment transport, including helicopters, small piston-powered aircraft, and large commercial jets. Aircraft emissions depend partly on the physical characteristics and performance parameters of each unique aircraft type. These include the airframe type, the type and number of engines, takeoff weight, and approach angle. In addition to the physical characteristics of the aircraft operating at the site, emissions further depend on the time that each aircraft type operates in the various modes that define a landing and takeoff cycle. A landing and takeoff cycle (LTO) consists of the approach, landing roll, taxi to and from the parking area, idle time, takeoff, and climbout. In addition to aircraft, surface-based vehicles are necessary. Aircraft emissions are likely to cause a negligible to minor impact to air quality.

4.7.2.3. Phase 3 (Post Spill and Long-term Recovery)

Following the removal or other disposition of the oil by burning, evaporation, or weathering, few, if any, additional recovery efforts would be required that would affect local air quality. However, during the long-term recovery process, there would be continued evidence of the VLOS and the affected areas onshore. In order for this recovery effort to proceed on a long-term basis, the continued use of marine vessels, small boats, aircraft, and surface vehicles would be required. Emissions from these sources would be far below the levels experienced during any of the previous phases of the VLOS. Considering the decrease in pollution sources and the meteorological conditions existing over the Arctic, particularly the potential for Arctic winds to disperse air pollutants, minor levels of effect to air quality would be expected.

4.7.2.4. Oil Spill Trajectory Analysis

The types of impacts to air quality analyzed above would be expected to occur regardless of the location of the spill's source. An oil-spill trajectory analysis is not provided.

4.7.2.5. Conclusion

A VLOS in the Beaufort Sea could emit large amounts of regulated potentially harmful pollutants into the atmosphere. The greatest deterioration of air quality would occur during Phase 1 and Phase 2, particularly if the spill occurs in the winter when fumigation conditions are more likely and precipitation is less frequent. Also, the potential of a Phase 1 fire and spread of surface oil would cause moderate to major levels of effect from PM and VOC emissions in the immediate vicinity of the flames. With distance from the fire and with further spreading of surface oil, the concentrations of VOC would be less severe but moderate effects could still occur around the Proposed Action Area. Impacts continue for days during Phase 1 but could continue for months under Phase 2. Therefore, while a major impact would likely occur during these two phases, and the emissions from the VLOS would be temporary and distributed over time, air quality in the Arctic would eventually return to pre-oil-spill conditions. Due to dispersion, impacts on air quality would be limited to the immediate area of the spill and are expected to be temporary. Concentrations of criteria pollutants would likely not exceed air quality standards in any onshore areas. The impacts of a VLOS on air quality would be minor.

4.7.3. Effects of a VLOS on Lower Trophic Level Organisms

This section assesses the potential for the hypothetical VLOS scenario described in Section 4.5.2 to impact the lower trophic organisms found within the physical environment of the OCS in the Beaufort Sea Planning Area and shoreward zone Alaska State waters. Lower trophic and benthic populations in Stefansson Sound could be strongly impacted by a VLOS, with a same-season to one-year loss of major proportions to all components of known lower trophic communities. The Boulder Patch would

be impacted for more than one year, possibly decades. In all phases of a VLOS, one or more of the lower trophic communities described in this section would be affected by the byproducts of oil created by natural and anthropogenic processes. This lower trophic section will define and describe in brief the potentially affected communities of lower trophic organisms, summarize pertinent information concerning the effects of a VLOS on lower trophic organisms. The hypothetical VLOS scenario included three seasons: summer, winter, and break up or freeze up. While the impacts of exposure to spilled oil would largely be the same for all three seasons, the responses and the size of the area affected by the spill would be impacted by the season in which it occurs. One exception to this is that epontic communities are unlikely to be impacted by oil exposure if a spill occurs during the summer. Oil spill trajectories for VLOS are the same as for large oil spills (see Section 4.5).

4.7.3.1. Phase 1 (Well Control Incident, Offshore Spill and Onshore Contact)

Lower trophic organisms could be exposed to impact producing factors such as explosion or fire, contact with oil, and contamination of or loss of access to preferred habitat during phase 1 of the VLOS scenario. An explosion and ensuing fire from a blowout of the well or pipeline would result in an increase of pressure and temperature of the immediate environment. Impacts would be similar to those discussed in the large oil spill section (Section 4.3.1.1). Near instantaneous changes in the chemical composition of the surrounding environment in the form of heat energy, followed by gas and oil being released to the surrounding seawater would initiate the release of oil to the water column. Severity of effects would be dependent upon released energy. The explosion and chemical changes in the water column would result in the loss of pelagic and epibenthic lower trophic organisms in the near vicinity of the wellhead. A localized event at that stage of the timeline would likely not cause effects at a population level. Sediment upheaval and re-distribution of sediments into the water column and their subsequent deposition on the seafloor could affect pelagic organisms within the plume and all benthic organisms buried by the sediments, respectively. The severity of the effects would depend on the force of the explosion, concentration within the water column, density of ejected sediments, and duration of the sediment plume within the water column before deposition to the sea floor. A fire at the surface could create localized effects on plankton populations due to heat of the fire and release of material as a result of the event, including oil, melting plastics and rubbers, and chemicals used by response crews in attempting to control the fire. Overall, the effects of an explosion and ensuing fire would likely not affect the lower trophic communities at a population level.

Oil is highly toxic to organisms with a small body size. Phytoplankton, zooplankton, and other lower trophic organisms are in contact with their aqueous environment through thin layers of membranous tissue, have short distances between those layers and internal organs, and rapid metabolic rates (Jiang et al., 2010; Newman and Clements, 2007). The smallest developmental stages of organisms with complex life cycles, such as the nauplii larvae of copepods and other crustaceans, are especially vulnerable to those effects (Hansen et al., 2011; USDO, MMS, 2004). Furthermore, many lower trophic organisms have the capacity to accumulate oil and oil toxins if they are not killed outright, thereby leading to bioaccumulation and biomagnification in upper levels of the foodweb (Neff, 2002; Newman and Clements, 2007). In particular, this includes copepods and other crustaceans (Hansen et al., 2011; USDO, MMS, 2004). The extent of effects is dependent upon numerous factors, including duration and volume of spill, persistence and dispersion of oil in the water column and the benthic surface, chemical composition of the oil and where it has accumulated (at the water surface, in the water column, or at the benthic surface), the efficacy of chemical dispersants should they be approved and utilized, the movement of oil through the water column, hours of daylight and UV intensity, seasonality and presence or absence of ice, how oil is incorporated into the ice during its formation, classification of ice, and presence or absence of polynyas and reaches. Potential effects of these factors on lower trophic populations are dependent upon their various combinations and include:

- Rapid accumulation of toxins within single cell algae and rapid death of these organisms within surface areas affected by oil slicks.
- If phytoplankton cell death does not instantly occur, drift and later ingestion by other organisms could lead to bioaccumulation at potentially large numerical scales.
- Although immediate effects of surface oil slicks could be serious to all affected components of neuston plankton populations, multi-year studies from previous oil-spill events indicate population-level recovery should be relatively rapid (one year or less) in marine phytoplankton populations.
- Populations of meroplankton (including instars, zooids, and nauplii; early larval developmental stages of numerous benthic and pelagic species) and adults of those species, depending upon factors listed above, may take one year or more to recover to pre-spill population levels if adults are affected by population-level losses from settling of oil on benthic surfaces.
- Results of experiments conducted on calanoid copepods indicated exposure to both sunlight and weathered Alaska North Slope crude oil resulted in mortality and morbidity (impairment of swimming ability and discoloration of lipid sacs) of 80-100% in test treatments of *Calanus marshallae*, while oil-only or sunlight-only treatments resulted in a 10% effect on mortality and morbidity.
- Adult copepods have a strong affinity for accumulation of polyaromatic compounds (PACs) within lipid storage vacuoles and an affinity to act as bioaccumulators of these toxins, enabling them to potentially be distributed by movements of water masses and affect upper-level predators away from primary spill area.
- Studies carried out with larval benthic King crabs and seagrass shrimp exposed to 2 ppm crude oil showed >50% mortality in the first 6 hours of exposure.
- Pelagic communities including squid, jellyfish, ctenophores, larvaceans, and pteropods are rarely affected by surface oil, but subsurface oil would affect these organisms and population effects would depend upon the area covered and persistence of oil in the water column. Use of dispersants could potentially negatively affect populations of these organisms, as knowledge of the efficacy of dispersants in cold water is limited.
- Benthic communities are affected by accumulation of oil at the ocean bottom, particularly when oil covers developing eggs and larvae of organisms that use the benthic surface for substrate attachment of these life stages, and when it penetrates the burrows of polychaetes, amphipods, and other organisms that create pathways through the upper surface layers of the benthic sediment.
- Similarly, epontic communities would similarly be affected by oil that accumulates under the subsurface of the ice, as many organisms (e.g., concentrations of ice algae) live on that surface and within the interstitial brine layers of the ice architecture.
- Persistence of oil through winter months to spring breakup could affect recovery and subsequent productivity of benthic communities, as ice algae in affected areas will not contribute to benthic productivity, and crustaceans (krill, for example) may not survive at population levels adequate to compare with pre-VLOS contributions to the productivity of under-ice pelagic and benthic communities and spring plankton blooms.
- Presence of oil in water or ice could affect attenuation (penetration) of light through the water column and ice by way of absorption and scattering of solar radiation.

- Presence of oil within polynyas and reaches would affect the capacity of these open-water biological hotspots to support algae and invertebrate populations that are sustained throughout the months of ice cover and contribute to benthic and pelagic productivity after the ice retreat.

Information for the bulleted list above was obtained from: Barron, 2007; Barron et al., 2008; Brandvik and Faksness, 2009; Brodersen, 1987; Iken, Bluhm, and Dunton, 2010; Hansen et al., 2011; Jiang et al., 2010; Newman and Clements, 2007; NRC, 2005; USDO, MMS, 2003, USDO, MMS, 2004, USDO, MMS, 2008.

Habitat loss due to oil contamination could impact lower trophic communities, especially in the Boulder Patch. Studies by Dunton and Schonberg (2000) and Konar (2007) indicate the Boulder Patch kelp beds are slow to recover from disturbance. Dunton and Schonberg carried out experiments removing kelp from their holdfast attachment sites, after three years there was only a 50% recovery in the denuded patches. Suspecting invertebrate grazing as a factor, Konar repeated the experiment using cages to prevent access by potential herbivores and reported no recruitment after two years, again demonstrating the slow recovery rate of these communities.

Nearshore coastal marine environments, with intertidal and subtidal floral and faunal communities, would likely experience the longest-term effects resulting from contact with oil. Organisms inhabiting these diverse environments are subject to similar effects as those listed in the previous section, but some factors are specific to onshore contact. Among these are the effects of solar irradiance and the risks of photo-enhanced toxicity from oil in shallow water environments. Although this mainly refers to oil spills as opposed to drifting and previously weathered oil, it is of relevance to the intent of this section. The ultraviolet regions of solar radiation can substantially increase toxicity and risks of polycyclic aromatic hydrocarbons (PAH) through photochemical modification of oil (Barron et al., 2008). A 2004 study funded by BOEM (then MMS) investigated persistence of PAH compounds in laboratory tests using shoreline soils collected from the Beaufort Sea, Port Valdez, and Cook Inlet areas. Through experimental work they concluded that some interactions between aromatic hydrocarbons and sediment organic matter may be irreversible, with field tests indicating they persist in all their collection areas from previous oils spills and natural seeps. River and creek delta areas exhibiting estuarine habitats would be affected through wind and tidal exposure from oil, and the potential impact of storm events. In 1970, Reimnitz and Maurer (1979) observed the effects of tidal surges from a major storm event that inundated low-lying tundra and delta regions on the Beaufort Sea shoreline, leaving debris lines from flotsam as far as 5,000 m (16,500 ft) inland. A storm of equal or greater magnitude could force weathered oil far inland and leave residue over wide areas of tundra and river shores. The effects to shoreward lower trophic communities would be reliant upon factors such as seasonality of spill, locations of onshore contact, and persistence of oil within the water before contact. Effects to lower trophic populations where oil contacts the shore zone could result in one to several years for recovery, depending upon area of contact and duration and severity of exposure.

4.7.3.2. Phase 2 (Spill Response and Cleanup)

Dispersants are a combination of surfactants and solvents that work to break surface oil into smaller droplets which then disperse on the surface and into the water column. The efficacy of the application of dispersants is dependent upon water temperature, water density, energy from wind and waves, solar radiation intensity, and exposure time, or residence time, of the dispersant in an environment (NRC, 2005). The application of dispersants can cause sinking of droplets and subsequent aggregation on the benthic surface (Word, Pinza, and Gardiner, 2008; NRC, 2005) and increased exposure of small organisms to oil due to the increased surface area from small particles created by dispersants.

In-situ burning is used to remove oil from the surface and to curtail oil slicks from reaching shorelines. In-situ burning could affect fish through elevation of surface-water temperature; boom dragging for oil collection; and sinking of residues. In-situ burning would cause elevated surface temperatures and creation and introduction of residues into the water column (Buist, 2003), and disturbance of the surface layers of the ocean, including the microlayer that serves as a concentration point for many forms of plankton (Wurl and Obbard, 2004). These effects on lower trophic organisms would differ depending on the time of year (open-water vs. ice-cover) and the size and duration of the burn. If an oil spill occurred in winter, in-situ burning would be limited by the lack of open water to collect oil and the area of open water in which to maneuver vessels and contain oil to an optimal thickness to burn (greater than 1-2 mm). If it could occur on a limited scale, sea ice would melt in the immediate vicinity of the burn and invertebrates associated with the ice would be negatively affected by the operation. Residues from in-situ burning can float or sink depending on the temperature and age of the residue. Floating residue can be collected; however, residues that sink could foul gills and expose benthic organisms to oil components as the residue degrades on the seafloor.

During the spill response and cleanup phase, lower trophic organisms could be exposed to a variety of effects from offshore vessel traffic. All activities requiring the use of watercraft would increase the disturbance of the lower trophic organisms and their habitats, particularly when these activities are carried out in nearshore environments. Skimming or vacuuming the microlayer would disturb chemical, physical, and biological processes that take place in this layer and could injure or kill sensitive pelagic life stages including Icebreakers would cause disturbance to ice habitat, and depending on the time of year, could affect the epontic community.

Spill response activities vary in their capacity to affect lower trophic populations. The length of time that response and cleanup activities continue would determine effects on lower trophic communities. In general, effects to phytoplankton and pelagic populations would likely be minor, but benthic and shore zone lower trophic populations could suffer greater effects of one or more years of recovery time.

4.7.3.3. Phase 3 (Post-Spill, Long-Term Recovery)

Impacts affecting lower trophic organisms in long-term recovery are similar to the previously described scenarios. As discussed with large oil spills, phytoplankton populations should recover quickly. Long-term and chronic effects would be most evident in populations of benthic and pelagic animals and organisms associated with the Boulder Patch kelp beds. Even with the recovery of zooplankton through the currents of surrounding waters and the reproductive capacity of resident populations of benthic and pelagic invertebrates, the recovery of invertebrate populations may take 1-2 years if the impacting factors analyzed in earlier sections should culminate in causing population-level effects to this diverse group of organisms.

4.7.3.4. Conclusion

The description of effects of contact and impacts should an oil spill contact lower trophic resources have been described in the preceding sections. Although the trajectories are similar, the amount of oil spilled would be greater, so the overall impact on lower trophic organisms would be greater. A VLOS would likely have less than a one year effect on phytoplankton populations. However, short-term, local-level effects would have greater potential to affect local food webs. Severity of effects would be determined by duration of oil spill, weather patterns, and the resultant distribution and geographic coverage of surface oil slicks. Invertebrate populations within benthic, pelagic, and onshore environments are at greater risks from a VLOS due to their slower reproductive rate, longer life spans, and the potential of adult breeding populations being negatively affected by the VLOS and leading to a longer recovery rate. Phytoplankton and zooplankton populations extirpated by oil slicks that are constantly shifting and forming in new areas due to influences of wind, weather, and waves, would not be available to organisms that depend on them for food and survival. Food webs can be

very short in the Arctic, with interactions between megafauna (i.e. whales, seals, walrus) and lower trophic organisms often comprising one or two trophic levels due to the tight benthic and pelagic coupling on the shallow continental shelf off the Alaskan Arctic coast (Dunton et al., 2005; Grebmeier et al., 2006). Bioaccumulation and biomagnification in these foodwebs is a concern. Long lived copepods (such as *Calanus glacialis*) may live 2-3 years, store lipids in the body cavity, undergo diapause (a form of hibernation), and be consumed by upper level predators (Pacific cod, bowhead whales, etc.) at a later date (USDOJ, MMS, 2004). Toxicity studies carried out with benthic crabs and shrimp indicate they may not immediately die from toxins (living 24-96 hrs, depending on exposure and oil type), thus allowing greater opportunities for consumption by upper-level predators and biomagnification to occur (Brodersen, 1987). Phytoplankton themselves may not die immediately from the effects of exposure to oil, allowing them to be consumed by other organisms in locations away from contamination sites (Jiang et al., 2010). Ice algae population effects would be determined by similar factors, as the presence of oil within polynyas and reaches, and if incorporated into first year ice would likely have at least a one-year effect on local populations due to effects on primary productivity and the probable inability of epontic communities reliant on ice algae to survive within oil-influenced ice. Recovery rates of one or more years may result from these effects on invertebrate populations, but cascading impacts would be expected throughout the food web. A VLOS would likely have major, persistent impacts on lower trophic communities in Stefansson Sound, especially to the Boulder Patch.

4.7.4. Effects of a VLOS on Fish

Very large oil spills could affect offshore and nearshore fish species in the path of or near the oil through effects such as acute toxicity or shifts in prey availability. The effects on fish and their populations would depend on a variety of factors including life stage, season of the reproductive cycle, species' distribution and abundance, locations of the species in the water column or benthos, the extent and location of spawning areas in riverine systems, and migratory patterns. The hypothetical VLOS scenario included three seasons: summer, winter, and break up or freeze up. While the impacts of exposure to spilled oil would largely be the same for all three seasons, the responses and the size of the area affected by the spill would be impacted by the season in which it occurs. Oil spill trajectories for VLOS are the same as for large oil spills (see Section 4.5).

Many journal articles have been published on the effects of the *Deepwater Horizon* oil spill on fish. Table 4.7.4-1 presents a summary of this journal literature. These articles document the injurious and acute effects of crude oil on the embryology, physiology, genetics, and behavior of various fish species and fish life stages.

Table 4.7.4-1. Journal Literature on the Effects of the *Deepwater Horizon* Oil Spill on Fish.

Title of Peer-Reviewed Article	Date	Authors
The effects of oil exposure on peripheral blood leukocytes and splenic melanomacrophage centers of Gulf of Mexico fishes	2014	Ali AO, Hohn C, Allen PJ et al.
Crude oil impairs cardiac excitation-contraction coupling in fish (1)	2014	Block B, Brette F, Cros C et al.
Crude oil impairs cardiac excitation-contraction coupling in fish(2)	2014	Brette F, Machado B, Cros C et al.
Oxidative stress responses of gulf killifish exposed to hydrocarbons from the <i>Deepwater Horizon</i> oil spill: potential implications for aquatic food resources	2014	Crowe KM, Newton JC, Kaltenboeck B et al.
Acute embryonic or juvenile exposure to <i>Deepwater Horizon</i> crude oil impairs the swimming performance of mahi-mahi (<i>Coryphaena hippurus</i>)	2014	Mager, EM, AJ Esbaugh, JD Stieglitz et al. 2014
<i>Deepwater Horizon</i> crude oil impacts the developing hearts of large predatory pelagic fish	2013	Incardona JP, Gardner LD, Linbo TL et al.
Influence of age-1 conspecifics, sediment type, dissolved oxygen, and the <i>Deepwater Horizon</i> Oil Spill on recruitment of age-0 red snapper in the Northeast Gulf of Mexico during 2010 and 2011	2014	Szedlmayer ST, Mudrak PA.
Spatio-temporal overlap of oil spills and early life stages of fish	2013	Vikebo, Ronningen, Lien et al.
Multitissue molecular, genomic, and developmental effects of the <i>Deepwater Horizon</i> Oil Spill on resident Gulf killifish (<i>Fundulus grandis</i>)	2013	Dubansky B, Whitehead A, Miller JT et al.

Title of Peer-Reviewed Article	Date	Authors
<i>Exxon Valdez to Deepwater Horizon</i> : Comparable toxicity of both crude oils to fish early life stages	2013	Incardona JP, Swarts TL, Edmunds RC et al.
Spatial, temporal, and habitat-related variation in abundance of pelagic fishes in the Gulf of Mexico: potential implications of the <i>Deepwater Horizon</i> Oil Spill	2013	Rooker JR, Kitchens LL, Dance MA et al.
Genomic and physiological footprint of the <i>Deepwater Horizon</i> Oil Spill on resident marsh fishes.	2012	Whitehead A, Dubansky B, Bodinier C et al.
Macondo crude oil from the <i>Deepwater Horizon</i> Oil Spill disrupts specific developmental processes during zebrafish embryogenesis	2012	de Soysa TY, Ulrich A, Friedrich T et al.
Response of coastal fishes to the Gulf of Mexico Oil disaster	2011	Fodrie FJ Heck KL, Jr.
Potential impacts of the <i>Deepwater Horizon</i> Oil Spill on large pelagic fishes	2011	Frias-Torres S, Bostater JC

4.7.4.1. Phase 1 (Well Control Incident, Offshore Spill and Onshore Contact)

Fish could be exposed to impact producing factors such as explosion or fire, contact with oil, and contamination of or loss of access to preferred habitat during phase 1 of the VLOS scenario.

In a VLOS explosion, demersal and pelagic fish would both be affected. An explosion would send percussive shock waves through the water, causing rapid increase in pressure, density and temperature in the immediate area of the explosion. Fish eggs, larvae, and adults on the seafloor and in the water column would be injured or killed from shock waves from an explosive event when pressure, density, and temperature rise rapidly in the immediate vicinity. The lateral lines and swim bladders of fish could be severely damaged. Fish injured by the explosion would have physical, physiological, and behavioral effects that could interfere with swimming, feeding, reproduction, and predator escape. Acute or chronic effects on fish from an explosion could carry into longer term effects on a population if a large proportion of the individuals were killed from a rare benthic community. Sensitive life stages in the surface waters (such as floating eggs of Arctic cod and drifting fish larvae) would be particularly affected by the explosion (shock wave, methane) and fire (heat and chemical reactions). The freshwater stages of anadromous fish would not be affected directly by an explosion and fire. An explosion could damage benthic habitat and cause high levels of suspended sediment and turbidity, which in turn could affect fish gills and respiration. Visibility for fish would be affected by the turbidity in the immediate area.

A fire would cause the surface water temperature to rise immediately which would be lethal for epipelagic fish, eggs and larvae. Subsurface water temperature would increase more slowly and could cause changes in physiological processes, particularly for benthic fish that are more sedentary. If a fire continued and sub-surface temperatures continued to rise, subsurface egg and larvae mortality could occur over time. Free-swimming fish not obligated to a specific habitat would likely move out of the area if the temperature continued to rise. Chemical reactions in the water, such as oxygen concentration, would be altered by rising temperature and this could also affect the physiology of fish.

Exposure to oil during a VLOS in Stefansson Sound could affect marine and anadromous fish and fish habitat through many pathways. Acute and chronic exposures could occur in riverine, estuarine, and marine environments which includes habitats in the water column, bottom sediment, and sea ice. The exposure pathways for fish include adsorption to outer body, respiration through gills, ingestion, and absorption of dissolved fractions into cells through direct contact. The severity of the effects on fish would depend on several factors including the type of oil/gas mixture spilled, the thickness of the oil spill, the duration of exposure on the surface, the season of the year (open-water, ice), and the life stage of the fish (egg, larvae, juvenile, adult). Following are the types of effects that could occur to fish from a very large oil/gas spill or release:

- Mortality of eggs and immature stages due to acute toxicity of oil and its weathered products
- Mortality of epipelagic eggs and larvae from acute coating with oil layer
- Mortality of adult fish in shallow coastal water bodies with slow water-exchange rates

- Mortality of eggs, immature and adult fish from shock waves from explosive event when pressure, density and temperature rise rapidly in the immediate vicinity
- Immediate loss of some marine, estuarine, and riverine habitats from physical oiling
- Contaminant effects on organs, tissues and gills, causing physiological responses including stress and altered respiration, irregular or reduced heart rate, and fluid accumulation; these effects can, in turn, affect swimming, feeding, reproductive and migratory behaviors and the physiologic adjustment for anadromous fish as they move between freshwater and saltwater environments
- Genetic damage to embryos resulting in morphological abnormalities which can affect ability to swim, feed, avoid predators and migrate
- Contaminant exposure in spawning or nursery areas causing abnormal development, or delayed growth through adsorption and ingestion; this abnormal development may repeat through generations if the population continues to spawn and/or rear offspring in contaminated areas
- Displacement of individuals or portions of a population from preferred habitat due to oiling
- Blocked or impeded access to or from spawning, feeding or overwintering freshwater habitats of anadromous fishes due to oiling of estuarine and freshwater environments
- Disruption or re-direction of coastwise migration of migratory and anadromous fish
- Reduction or elimination of prey populations normally available for consumption
- Reduction of individual fitness and survival, thereby increasing susceptibility to predation
- Long-term chronic contaminant effects in fish habitats from weathering oil which produces highly toxic Polycyclic Aromatic Hydrocarbons (PAHs), especially to lipid-rich eggs
- Decreased recruitment into the population due to mortality, abnormal development of eggs and larvae, truncated adult lifespan, reduced adult fitness, increased predation, increased parasitism, and zoonotic diseases
- Intraspecific cascade effects, such as loss of key individuals in social groups, which may show delayed effects on reproduction or feeding behaviors
- Modification of community structure due to increased mortality, reduced recruitment, decreased prey availability, loss of year classes and increased predation
- Modification of ecosystem due to reduction of fish eggs, larvae and adult fish available to predators including seals, sea birds, other fish species and toothed whales, indirectly to polar bears
- Cumulative effects from acute and chronic oil effects overlain on other contemporary stressful events such as water temperature rise, ocean acidity increase and decreasing sea ice

Information for the bulleted list above was obtained from: Nahrgang et al., 2010; Boertmann, Mosbech, and Johansen, 1998; Jonsson et al., 2010; Pearson, Woodruff, and Sugarman, 1984; Pinto, Pearson, and Anderson, 1984; Moles and Wade, 2001; Heintz et al., 2000; Christiansen and George, 1995; Mahon, Addison, and Willis, 1987; Ott, Peterson, and Rice, 2001; Rice et al., 2000; Carls, Harris, and Rice, 2004; Short et al., 2004; Peterson et al., 2003.

Loss of access to preferred habitat can impact the spawning, rearing, and feeding strategies of fish. Anadromous fish, because they depend on several environments in their complex life history, can be particularly impacted if oil reaches mouths and deltas of anadromous streams and rivers. Oil on the coastline presents a barrier to access (or egress) to spawning, feeding, overwintering and coastwise migration for anadromous species. A VLOS could wash over river deltas, into river mouths and be transported upstream by tidal action or anadromous fish returning to spawn and die in their natal waters. Oil in anadromous water bodies would present contaminants to sensitive spawning areas and

life stages. There are many anadromous rivers, streams and lagoons along the Chukchi Sea Coast and Western Beaufort Coast from the Bering Strait to Nuiqsut. Anadromous fish that would be affected by a VLOS in the Beaufort Sea include: Pacific salmon (pink, chum, king, coho, sockeye), least cisco, Bering cisco, Dolly Varden, broad whitefish, humpback whitefish and Arctic char. Several fish species such as capelin, sand lance, saffron cod, and some sculpin species are not considered anadromous but they use nearshore substrates for spawning and rearing habitats. Nearshore species would be affected through similar pathways as anadromous fish if an oil spill hit the nearshore or shoreline, particularly during critical spawning or rearing times.

Acute and chronic effects of oil on nearshore and intertidal fish, eggs, and larvae can have cascade effects on fish populations over time. Sand lance would be especially affected in their nearshore habitats because they burrow in sand when they are not out foraging in the water column and they also overwinter in those burrows. Experiments have shown that sand lance are affected negatively by oiled sediments (Pearson, Woodruff, and Sugarman, 1984; Pinto, Pearson, and Anderson, 1984; Moles and Wade, 2001).

Offshore fish species would experience a variety of effects from a VLOS depending on its life history stage (adult, sub adult, egg, larvae); its habitat association (bottom dwelling, mid-water column, upper water column, beneath ice or in ice crevices); the range of depth inhabited; the breadth of the species habitat, prey and range; the life history and behaviors of the species (migratory, sedentary, reproductive strategy, etc); and plasticity of the species to adjust to environmental stressors.

Sedentary, burrowing, territorial, benthic-obligated fish, fish eggs and fish larvae exposed to oil or gas would be limited in their ability to escape or avoid contaminants due to their limited swimming behaviors, obligate life history characteristics, behavioral traits, or spatial limitations. The exposure concentration that these species (including some poachers, eelpouts, sculpin, flounders, snailfish, nesting saffron cod) would experience could be greater than that to which free-swimming fish would be exposed. Fish that can swim relatively faster and more efficiently (such as salmon and cod) would more likely avoid some of the effects of oil at various concentrations if they have the sensory ability to detect oil or gas components.

Some fish species associate with sea ice to feed, hide, and spawn. Most notable of these in the Beaufort Sea is the Arctic cod which associates with ice in various life stages and seasons for shelter and as a forage habitat to feed on microorganisms on the underside of the ice. Under-ice amphipods are an important food source for Arctic cod (Lonne and Gulliksen, 1989; Gradinger and Bluhm, 2004). Rough, irregular textures of the underside-ice may provide preferred habitat for Arctic cod to avoid predators (Cross, 1982). Arctic cod migrate between offshore and onshore areas for seasonal spawning. They spawn under the ice during winter months (Craig et al., 1982; Craig, 1984; Bradstreet et al., 1986). Eggs hatch under the sea ice after 40-60 days and young larvae remain under the ice, eventually settling towards the bottom in September (Craig, 1984; Graham and Hop, 1995).

Oil and gas released in a winter scenario would pool under the ice in pockets presenting prolonged exposure to Arctic cod eggs and larvae, hiding adults, and amphipods inhabiting the under-ice environment. Pooled under-ice oil could take several pathways between winter and summer months: remain pooled on the underside of ice and drifting with ice; remain pooled in open leads; entrain or encapsulate in ice; dissolution into water column; or sinking adhered to sediment (Tables A.1-1, A.1-2). Melt-out of annual sea ice in spring and summer would release oil pooled underneath and trapped in ice and leads. All of these pathways would affect offshore and nearshore Arctic cod and other fish species, including those living in association with ice and those in the water column below ice and ultimately the benthic species affected by sinking oil-laden particulate.

4.7.4.2. Phase 2 (Spill Response and Cleanup)

Dispersants are a combination of surfactants and solvents that work to break surface oil into smaller droplets which then disperse on the surface and into the water column. Many factors affect the behavior, efficacy, and toxicity of a particular dispersant including water temperature, surface salinity, wave and wind energy, light regime, water depth, type of oil, concentration of dispersant, how the dispersant is applied (constant or intermittent spikes) and exposure time to organisms. Dispersants are used to degrade an oil spill more quickly through increasing surface area and to curtail oil slicks from reaching shorelines (Word, Pinza, and Gardiner, 2008).

Application of dispersants can cause toxic effects in fish and particularly fish eggs and larvae. Fish can be affected by dispersed oil through adsorption, ingestion, absorption of dissolved components and respiration (Word, Pinza, and Gardiner, 2008). As oil breaks into smaller droplets and sinks in the water column, the droplets are more likely to be ingested by fish that inhabit the water column. Because the surface area of oil increases as it is broken into droplets, there is an increased chance of fish, eggs and larvae in the water column coming into contact with the dispersed oil (Word, Pinza, and Gardiner, 2008). If oil droplets adhere to sediment and sink to the seafloor, benthic fish eggs and larvae would then be exposed to oil. In shallow nearshore waters, wind, wave and current action would more likely mix the dispersant-oil mixture into the water column and down to the seafloor which could foul gills and cause changes in histopathology of the gills (Khan and Payne, 2005).

The effect of dispersant application in a VLOS in the Beaufort Sea would be similar to the toxicity and fouling effects described above and in the large oil spill section. Epipelagic fish eggs and larvae would be particularly sensitive to effects of dispersant application. Fish in the water column and the benthos would be variably affected as a function of the species, life stage, depth inhabited, time of reproductive cycle, feeding strategy and ability to adapt by sensing the chemical changes and moving out of the range of toxic effects.

In-situ burning is used to remove oil from the surface and to curtail oil slicks from reaching shorelines. In-situ burning could affect fish through elevation of surface-water temperature; boom dragging for oil collection; and sinking of residues. These effects on fish would differ depending on the time of year (open-water vs. ice-cover) and the size and duration of the burn.

The upper-most layer of water (upper millimeter or less) that interfaces with the air is referred to as the microlayer. Important chemical, physical and biological processes take place in this layer and it serves as habitat for many sensitive life stages including fish eggs, fish larvae, and microorganisms important as prey for fish. Disturbance to this layer through boom-dragging to collect oil and temperature elevation from burning could cause lethal effects on fish life stages in this layer. In open water, the effects would be limited to the surface area burned and to the duration of a burn in any one area. Free-swimming adult fish not obligated to a specific habitat would likely move out of the area.

If an oil spill occurred in winter, in-situ burning would be limited by the lack of open water to collect oil and the area of open water in which to maneuver vessels and contain oil to an optimal thickness to burn (greater than 1-2 mm). If it could occur on a limited scale, sea ice would melt in the immediate vicinity of the burn and fish associated with the ice would be negatively affected by the operation. Residues from in-situ burning can float or sink depending on the temperature and age of the residue. Floating residue can be collected; however, residues that sink could foul gills and expose benthic organisms to oil components as the residue degrades on the seafloor.

The NOAA Office of Response and Restoration states that, "Overall, these impacts [from open-water in-situ burning] would be expected to be much less severe than those resulting from exposure to a large, uncontained oil spill" (<http://response.restoration.noaa.gov/oil-and-chemical-spills/oil-spills/resources/in-situ-burning.html>).

During the spill response and cleanup phase, fish could be exposed to a variety of effects from offshore vessel traffic. Noise from ships, sound from seismic surveys and other sound sources would affect fish through interference with sensory orientation and navigation, decreased feeding efficiency, scattering of fish away from a food source, redistribution of fish schools and shoals, and producing a generalized stress response in some fish species which can weaken fish immune systems (Fay, 2009; Jobling, 1995; Radford et al., 2010; Simpson et al., 2010; Slabbekoorn et al., 2010; Purser and Radford, 2011; Wysocki, Dittami, and Ladich, 2006). Pelagic species, such as adult Arctic cod, adult salmon and similar species would startle and scatter as noise continues and, in theory, receive reduced levels of sound. Sedentary, burrowing, territorial, benthic-obligated fish, shallower near-shore fish, fish eggs and fish larvae in the area of the rig and oil spill would be exposed to higher noise levels due to their limited swimming behaviors, obligate life history characteristics, behavioral traits or spatial limitations. Foraging and reproduction behaviors of these benthic-obligate fish could be affected negatively by seismic activities and noise. Skimming or vacuuming the microlayer would disturb chemical, physical, and biological processes that take place in this layer and would injure or kill sensitive pelagic life stages including fish eggs, fish larvae and microorganisms that are important prey for fish. Icebreakers would cause disturbance to ice habitat, and depending on the time of year, could affect the eggs and young larvae or Arctic cod.

4.7.4.3. Phase 3 (Post-Spill, Long-Term Recovery)

In long-term recovery, there would be a continued presence of people in the area for monitoring and research. Monitoring and research would include small boat and aircraft landings on shorelines and people walking and wading through aquatic habitats. These activities could result in trampling of fish habitats, noise and disturbance to fish and removal of fish from the system for research purposes.

Over the long term, contamination of aquatic environments from oil (and possibly dispersant residue on the seafloor) would continue from oil breakdown products such as PAHs. Sunlight (UV radiation) increases the toxicity of PAHs, so summer sunlight in Arctic Alaska may exacerbate the amount and degree of toxicity exposure.

Long-term chronic effects from oil would occur in fish that occupy estuarine, intertidal and freshwater habitats where oil accumulates and weathers, producing PAHs especially toxic to lipid-rich eggs. If chronic exposures persist, stress may manifest sublethal effects later in the form of histological, physiological, and behavioral responses, including impairment of feeding, growth, and reproduction (Heintz et al., 2000). Chronic toxicity and stress may also reduce fecundity and survival through increased susceptibility to predation, parasite infestation, and zoonotic diseases. The frequency of a single symptom does not necessarily reflect the effects of oil on the organism, so the cumulative effects of all symptoms of toxicity must be considered in evaluating acute and chronic effects of oil on fish.

Contaminant exposure can make a spawning site unavailable for multiple generations if the oil is detectable by the fish. If a population continues to spawn and/or rear offspring in oil-contaminated areas, abnormal development, genetic alterations or abnormal behavior may repeat through successive generations. The likely results would be fewer juvenile fish survive, so that recruitment from the early life stages is reduced and adult populations decline. Declining adult populations may not be replaced at sustainable levels. Ultimately, these cumulative effects on individuals can affect the population abundance and, subsequently, community structure (Patin, 1999; Ott, Peterson, and Rice, 2001; Rice et al., 2000). Moles and Norcross (1998) documented deleterious effects on juvenile flatfish species, including yellowfin sole, that were exposed to sediments laden with Alaska North Slope crude oil. The effects of this controlled laboratory experiment included changes in tissues and significant decreased growth rates in yellowfin sole juveniles at 30, 60 and 90 days of exposure.

Furthermore, as result of environmental stress and changes resulting from oil spills and a warming environment due to climate change, previously unknown fish populations could move into a new areas and complicate recovery (Cheung et al., 2009).

4.7.4.4. Conclusion

The impacts of a VLOS in the Beaufort Sea on a fish species and its population would depend on many factors including life stage affected, species distribution and abundance, habitat dependence (ocean water column, sea surface, benthos, sea ice, estuarine, freshwater), life history (e.g., anadromous, migratory, reproductive behaviors and cycle, longevity) and spawning location, exposure level to oil or dispersants, effects on the food web, and seasonality of the spill. Although the spill trajectories are the same as were described for large oil spills, the amount of oil spilled would be greater, so the overall impact on fish would be greater. Considering all these factors, especially food web and spawning requirements, a VLOS in Stefansson Sound would likely have major impacts on fish resource, and would persist for multiple generations. The species that would be particularly vulnerable to effects at individual and population levels include: saffron cod, Arctic cod, sand lance, capelin, nearshore sculpin species, nearshore flatfish, migratory least cisco, migratory Dolly Varden, migratory Arctic char, rainbow smelt, stickleback, and migratory whitefish. Other fish species that would be affected by a VLOS include snailfish, eelblennies, eelpouts, poachers, offshore sculpin, and alligatorfish.

4.7.5. Effects of a VLOS on Birds

BOEM analyzed effects of a Very Large Oil Spill (VLOS) greater than or equal to a worst case discharge of 4.61 million barrels of oil released over 90 days after a catastrophic event such as a developmental drilling well blowout. A VLOS is a low-probability event with the potential for major effects. Exposure to oil from a VLOS would have similar types of impacts on birds as spills of other magnitudes (Section 4.3.3); however, the area and the number of individuals, and possibly species, likely affected would increase, and the degree of impact would be more severe because of the much larger volume and duration of the oil spill. A VLOS can affect extensive areas of shoreline, and with the number of birds and habitat area affected, long-term and population-level impacts for some species could be incurred. The precise nature and magnitude of the effects on bird populations from a VLOS resulting from the Proposed Action would depend on the timing of the spill and environmental conditions such as sea ice presence, and the species, life stages, and range of habitats exposed to it. For purposes of analysis, the VLOS scenario is divided into phases, and the adverse effects on birds that could result during each phase are described in the following sections.

4.7.5.1. Phase 1: Well control incident, offshore spill, and onshore contact

Oil in the Beaufort Sea would be a serious threat to waterbirds, including foraging waterfowl, phalaropes, seabirds and loons, because of its properties of forming a thin, liquid layer on the water surface. BOEM's VLOS modeling also shows that a very large oil spill originating in summer at the proposed LDPI would have a 17% chance of reaching the shore of the Sagavanirktok River Delta within 1 day, and 33% within 90 days (Appendix A, Tables A.2-25, A.2-29). Birds, if present, would therefore be vulnerable both in marine waters and in intertidal areas on shore during this phase.

As with large spills, seabirds and waterfowl are initially most vulnerable to offshore oil spills because they spend the majority of their time in marine waters and often aggregate in dense flocks. Direct exposure to oil would be the most critical VLOS impact on birds during Phase 1. Bird deaths due to oil spills are described in Section 4.3.3 and primarily arise from exposure from wetting and loss of thermoregulatory ability, loss of buoyancy and waterproofing, or from matted plumage, inability to fly or forage, ingestion and inhalation of vapors.

Waterbirds are vulnerable throughout the open-water season, beginning with their spring arrival in the open-water leads. Large numbers of shorebirds and waterfowl could come into contact with spilled oil along shoreline areas and could be affected during spring arrival, breeding, post-breeding, molt, or fall migration through oil exposure and subsequent hypothermia or other means of mortality. They could also be affected by eating contaminated intertidal prey or through mortality in their invertebrate food sources, as could scavengers and predators such as ravens and raptors. The species potentially impacted the most are the same as those previously described for a large spill (4.3.3). Some species anticipated to have the highest rates of exposure and impacts in the case of an unlikely VLOS are discussed further below.

ESA-listed Species

Like other sea ducks, spectacled and Steller's eiders must stage offshore in the spring open-water leads unless or until their local tundra breeding habitats become available in late May through mid-June. Between late June and the end of August, non-breeding, failed-breeding, and post-breeding spectacled eiders are commonly found foraging in the marine waters of the Proposed Action Area, including off the Sagavanirktok River Delta and in Foggy Bay. Approximately 540 spectacled eiders have been estimated outside of the barrier islands between Harrison Bay and Camden Bay in these months (Stehn and Platte, 2000), and a few birds may be present in to October. The birds are broadly distributed and do not tend to form dense flocks at this time of year, and a hypothetical VLOS would not be expected to spread uniformly in all directions, so it is unlikely that all birds present in the Central Beaufort Sea area would be directly contacted. Should a VLOS occur and spread during most periods of local eider activity, many, potentially on the order of 100, spectacled eiders could be contacted. Additionally, the fish and lower trophic resources on which eiders feed would be expected to incur major impacts from a VLOS. Female eiders are generally faithful to breeding sites, while males are not (Sexson, Pearce, and Petersen, 2014). Because VLOS prey impacts could persist for several years, they could have major impacts on the locally breeding females, as well as to new males each year of prey impacts. If not lethally impacted by contact therefore, hundreds of spectacled eiders could be otherwise adversely affected by prey contamination, and those impacts would be spread across several years, i.e., long-lasting. Impacts to 400-500 spectacled eiders, or about 3% of the estimated 14,800 ACP breeding population, that persist over several generations would be considered long-lasting and severe, and the loss of as few as a hundred spectacled eiders would be expected to have major impacts to the local Central Beaufort Sea breeding population for similar reasons.

Steller's eiders make little use of the Sagavanirktok River Delta and Foggy Bay, their ACP population is small (possibly less than 1,000) and their distribution is limited. One Steller's eider was recorded 41 km offshore of the Maguire and Flaxman Islands in a September survey (Morgan, Day, and Gall, 2012), and a flight-capable brood was reported on an inshore lake near the Sagavanirktok River (Quakenbush, et al, 2002). BOEM's oil spill modeling (see below and Table 4.7.5-1) indicates that, should a VLOS occur, there is no more than a 5% chance that oil would reach Prudhoe Bay waters or west, where Steller's eider are more likely to be found. While it is possible that two or three Steller's eiders could be contacted by oil should a VLOS occur, this would represent less than 1% of the total ACP breeding population, likely at the eastern limit of their current breeding range, and be considered a minor level of impact.

Non-listed Species

Waterfowl

Long-tailed duck and king eider could experience mortality of hundreds or thousands of individuals if exposure occurs at periods of peak use of nearshore waters (lagoon system) between the barrier islands and mainland. Long-tailed duck is typically the most locally abundant sea duck species over the course of the open-water season, occurs in high density, flightless molting flocks, and would be likely to incur high rates of contact. Large numbers of sea ducks initially appear as leads open in

marine waters in spring. Hundreds may be present initially but it is possible that several thousand long-tailed ducks and king eiders could use marine waters in the vicinity of the Proposed Action Area over the first year of a VLOS because of the on-going arrival of individuals moving through during migrations. For example, many king eiders stopping on spring migration breed locally while others go on to breed in Russia or farther east in Canada (Dickson et al, 2012, Quakenbush et al, 2009). A VLOS could impact not just local breeders but birds from some of these larger Arctic populations that move through the area during migration. These larger Arctic populations may number in the hundreds of thousands so losses in the thousands would not be expected to result in population-level impacts, but would be considered widespread. Other sea ducks such as common eider and scoters could also experience high rates of exposure and mortality to their local breeding populations, and some less severe mortality impacts to migrants and greater ACP populations. Additional numbers of surviving sea ducks would be affected by the year-long impacts on lower trophic prey, and possible decade-long impacts in the Boulder Patch.

Geese vulnerable to a hypothetical VLOS in the Proposed Action Area are greater white-front goose, Pacific black brant, lesser snow goose, and Canada goose. Greater white-fronts are the most abundant goose breeding on the ACP. Snow geese are colonial nesters that nest in only a few places in Alaska, all on ACP coastal habitat. One of their largest colonies has been on the Sagavanirktok River Delta where they nest on Howe Island, and sometimes Duck Island. Brant nest colonially primarily in shoreline habitat between the Colville and Canning Rivers, in the general Central Beaufort Sea coast vicinity of the Proposed Action Area. In the event of a VLOS, potentially thousands of geese would be vulnerable to contact while foraging or resting in nearshore waters during staging or breeding.

Post-breeding geese move, often in large flocks, in to protected deltas and inlets and on to nearby large lakes, including the lakes north of Teshekpuk Lake, to undergo a flightless molt. If a VLOS spread to the Colville River Delta or west, these molting geese would be vulnerable to direct contact and/or loss of forage, depending on time of year. They would also be vulnerable should oil be moved onshore by storm surges or ice movement in to lake molting habitat, which may move closer to shore over time with climate change-driven shoreline erosion (Flint, Whalen, and Pearce, 2014). If oil contamination of geese molting habitat caused food resources to be depressed for several years, long-term impacts would be expected. Tens of thousands of greater white-front geese can molt in the lakes northwest of Teshekpuk alone. Because they have a large overall population and have been increasing in abundance, impacts to greater white-front geese here would not have population-level, or likely more than moderate impacts. The other species also have relatively much larger populations overall beyond their Central Beaufort Sea coast populations, and also have been increasing in abundance, so VLOS effects would be generally limited to long-lasting but less than severe, and therefore moderate impact. Other potential waterfowl impacts could include dozens of breeding tundra swans foraging in marine and coastal habitat, but this species is also increasing across Alaska and these impacts would be considered minor. A large proportion of the Alaska-breeding population of lesser snow geese currently nests on the Sagavanirktok River Delta; therefore, this particular waterfowl population could potentially incur a major level of impact should a VLOS occur. In summary, waterfowl populations in the Proposed Action Area could experience impacts ranging from minor to major, should a VLOS occur.

Seabirds and Loons

Several species of seabirds could experience widespread mortality in pelagic waters from a VLOS. Arctic tern is a locally abundant forager in pelagic waters in the summer, and also a common breeder onshore in the Proposed Action Area. A VLOS could not only cause wide-spread mortality of adults, but of chicks as well, if adults bring contaminated food or residual oil on their feathers back to nests. The local population of this species could incur high levels of mortality and sublethal effects. As with many of the waterfowl discussed above, Arctic tern's wide ranging and abundant overall population would prevent the species itself from incurring more than minor impacts.

Impacts to black guillemots could be extensive if a spill extended to the ice edge, where these birds are known to forage. The abundance of prey items could be reduced or contaminated with oil, resulting in impacts to black guillemots, even if they are not directly exposed to oil. Because of their higher abundances outside of the Beaufort Sea, population-level effects are not expected; however, the greater relative abundance of piscivorous birds, and impacts to these birds, could potentially mean alterations of local trophic relationships.

Ross's gulls and ivory gulls are ice-associated birds and breed well outside the Proposed Action Area, but are regularly seen foraging in the Beaufort Sea. This species could incur mortality similar to black guillemot if a hypothetical VLOS was in close proximity to the ice edge, and as there are some indications that they may be in decline (Joiris, 2016), it is possible that they could sustain long-lasting impacts.

As a common breeder and pelagic forager, glaucous gull could be affected in large numbers through direct contact, contaminated food, and nest contamination. Owing to its overall large population, a VLOS would probably not have population-level effects. Sabine's gull is also a local breeder and pelagic, surface-feeding gull that begins arriving in the Proposed Action Area in late May, but occurs in lower abundances than glaucous gull. Foggy Island Bay appears to be an important ACP breeding area for Sabine's gull, however, and therefore a VLOS that impacts this population may have severe long-term impacts to the local population.

Hundreds or thousands of short-tailed shearwaters could be contacted and killed by spilled oil. Short-tailed shearwaters are widespread across the Beaufort Sea in summer and fall. Flocks of shearwaters could number in the tens of thousands. Most, but not all, foraging shearwaters tend to occur farther offshore however, so numerous flocks would be more likely to be encountered if the VLOS trajectory went in to offshore waters, beyond the barrier islands. They forage on patchily distributed zooplankton, euphausiids, and small fish in pelagic waters, and the non-uniform distribution of these birds could favor their survival during a VLOS or lead to extensive mortality. Their large population (20-30 million in the northern hemisphere) is unlikely to be affected, and impacts therefore considered temporary, even though large numbers of individuals could be contacted with oil or eat contaminated food.

Jaegers are present in low concentrations throughout the Beaufort Sea. Spilled oil could contact and kill jaegers as they spend most of their time foraging or resting on the sea surface. The likelihood of large-scale mortality and population-level impacts to jaegers is minimal because they occur in low densities and fewer than 100 would probably be affected.

Loons using the Beaufort Sea typically migrate close to shore until they are near their tundra breeding grounds. Loons using nearshore areas could be affected by oil contact early in the open-water season. A hypothetical VLOS could affect nearshore areas used by nonbreeding loons or, later in the open-water season, loon broods. Loons are known to occur far offshore once the water opens up however, and typically are widely dispersed while foraging. Pacific loons, typically the most numerous in the Proposed Action Area, could experience 100 or fewer deaths. Yellow-billed and red-throated loons may suffer dozens of mortalities. While these species may have incurred recent declines, impacts of this magnitude for species breeding across the ACP would be considered less than severe.

Shorebirds

Phalaropes, as common foragers on patchily distributed zooplankton in Beaufort Sea waters, could experience hundreds of mortalities. This would be particularly true late in the open-water season (i.e., post-breeding), when they are believed to be most abundant in marine waters. Red-necked phalaropes are considered more common in the Beaufort Sea and red phalaropes more common in the Chukchi Sea, but both regularly occur and could be vulnerable in the Beaufort Sea.

Given the high variability in shorebird abundance at migration stopover sites, a VLOS that contacted shoreline habitat could affect either a few shorebirds or almost every shorebird using an area, depending on when the spill occurred. Between July and September, migrating flocks can number in the thousands of birds, and new thousands can arrive from outside areas daily during peak migration. If several flocks were contacted by spilled oil, mortality in the thousands of one to several species of shorebirds could occur. See Section 4.3.3 Large Oil Spills for a list of affected bird species. Prior to migration, dozens of locally breeding shorebirds or their nests could be contacted or contaminated by shoreline oil, and breeding and migration foraging habitat and food sources could be impacted or lost for years, impacting many more birds. The loss of thousands of several shorebird species each at a migratory stopover would be considered a widespread impact in the migratory sense, but not severe relative to many population sizes, and population recovery would likely occur in fewer than three generations (once oiled habitats had recovered) if population trends continued to be stable. Some species that are less abundant, declining, or have more restricted ranges, such as buff-breasted sandpiper, could potentially incur longer-lasting effects to a larger percentage of their population, and therefore severe impacts.

Other Birds

If oil from a hypothetical VLOS reached the shoreline or further inland, other birds could be impacted. For example, dozens of common ravens and raptors could be impacted if they fed on contaminated items at the shoreline, and could bring oil back to contaminate their nests. Dozens of Lapland longspurs and other breeding landbirds could potentially be affected via prey, perch, nest, or water fouling if oil from a VLOS was moved ashore on to coastal breeding habitat. These birds are generally territorial in breeding distribution and not susceptible to exposure in high density numbers. Breeding habitat and food sources could be impacted for several years, but the loss of dozens of these abundant birds, even over several years, would likely be limited to a minor level of impact.

4.7.5.2. Phase 2: VLOS response and cleanup

Spill response activities could disturb and displace birds, and potentially directly cause lethal impacts to some nests. The specific types of impacts that birds may experience from large spill response and cleanup as discussed in 4.3.3 would also be experienced by birds in the event of VLOS response and cleanup. These include loss and damage of food resources from mechanical spill response; loss of nests to cleanup worker disturbance or inadvertent crushing; and disturbance and displacement from preferred foraging, nesting, brood-rearing, molting, or staging habitats, potentially leading to reduced fitness. It is possible that displacement could have net beneficial effects on some birds by intentionally or unintentionally moving them away from oiled areas. This displacement may move birds to unoiled areas, with low energetic costs, if these habitats were of similar quality. For purposes of conservative analysis, however, BOEM assumes that the majority of birds so displaced would be moved to either inferior habitats or nearby oiled areas, and therefore experience net negative impacts.

In the event of VLOS response and cleanup, there would be additional impacts beyond those detailed for large spills. Work camp and storage area construction could disturb birds, and damage or cause the loss of nesting or terrestrial foraging habitat. Arctic wetlands are slow to naturally rehabilitate, so unmitigated tundra or wetland damage could cause decades-long habitat impacts. However, such habitat impacts are not expected to be large in area relative to surrounding undisturbed habitat. Unless they occur in particularly unique or sensitive habitats, impacts should be localized. If, however, worker or camp presence was situated on the only unoiled shoreline available for several miles, or otherwise blocked access to nesting common eider or nighttime staging shorebird roosts, impacts could be amplified. Expected repeated and substantial anchoring of response vessels and spill containment booms could also lead to long-term degradation or loss of small but numerous areas of marine foraging habitat. Depending on location and the quality of food resources potentially damaged, these impacts too could have long-lasting impacts on birds. If present, birds themselves

would also be purposely hazed in attempts to get them to avoid oiled habitats, and oiled birds may be chased, handled, kept confined, or otherwise in effect “hazed” as part of rescue attempts.

The magnitude and duration of spill response impacts would be larger for a VLOS than for a large spill. The duration of cleanup activities may preclude birds from successfully using the area for an entire season or more, which could disrupt survivorship or productivity. Cleanup of the *Exxon Valdez* VLOS took more than four summers (EVOSTC, 2014). If disturbance from either a summer or winter VLOS continued in an important habitat site for multiple years, these impacts could increase for certain birds such as nesting common eider. If response and cleanup impacts occurred for repeated years in the most vulnerable habitats when birds were present (e.g., common eider barrier island nest habitats and shorebird staging areas), response impacts alone could be long-lasting and widespread. As long as oil remained in the same environment, however, these spill recovery efforts would have both negative and positive effects, in that they may keep some birds from additional contamination impacts. It is unlikely that response activities would occur in repeated years across large enough proportions of a population’s habitat to have major impacts, so Phase 2 net impacts would likely increase, but remain minor to major for most of the same species.

4.7.5.3. Phase 3: Post spill and long-term recovery

A VLOS would cause long-term adverse effects (i.e., 2 years or more in duration) to coastal and estuarine migratory bird habitats. Long-term loss of breeding and forage habitat would occur where shoreside camps and storage areas displace tundra. Contamination of food resources or nesting substrates could lead to reduced fitness and productivity. Sections 4.3.1 and 4.3.2, describe how spill response may have long-lasting impacts on shorezone and benthic lower trophic food resources (Section 4.3.1), and widespread and persistent impacts on fish prey resources (Section 4.3.2), which could in turn have long-term consequences for many bird species, including benthic feeding sea ducks, staging shorebirds, piscivorous seabirds and loons, and others. After the *Exxon Valdez* oil spill (EVOS), the extent and degree of oiling on shorelines decreased rapidly over the first few years, and it was assumed that remaining oil would be reduced to negligible amounts soon thereafter (Neff et al., 1995). However, long-term studies have raised concerns that the tiny fraction of largely unweathered lingering oil remaining for decades in intertidal sediments of some beaches may have exposed a few fish and wildlife populations as well as the nearshore ecosystem to chronic impacts (Esler et al., 2015). Most marine bird populations appear to have recovered from the EVOS, but in some cases have taken ten years or longer (Lance et al., 2001; Stephensen et al., 2001; Wiens et al., 2004; McKnight et al., 2006; Esler and Iverson, 2010). Harlequin duck, for example, appears to have experienced such long-term impacts (Esler et al., 2015), and although it does not occur in the Beaufort Sea, its experience could indicate that other sea ducks with nearshore benthic feeding requirements may have similar vulnerabilities. Despite differences in species composition between the Gulf of Alaska (GoA) and Beaufort Sea, Beaufort Sea birds would probably not have more resilience to VLOS impacts than GoA birds.

Post-spill avian impacts would also continue to be widespread because of the extreme migratory nature of Arctic-breeding birds. The *Deepwater Horizon* VLOS was reported to have potentially affected bird populations, depending on their migration patterns, as far away as Alaska and northern Canada, Central and South America, or the Caribbean (Corn and Copeland, 2010; Deepwater Horizon NRDA Trustees, 2016). In other words, almost all birds that could be impacted move to other places distant from the Proposed Action Area to molt, winter, and in some cases breed. As described under Effects for Phases 1 and 2, the numbers of birds affected relative to overall population levels for most species would keep the long-term and widespread impacts from becoming severe. However, for some populations that are more limited in geographic scope or abundance, or are potentially declining or

increasingly vulnerable to climate change impacts, (e.g., common eider), severe impacts could continue through the post-spill recovery period.

Oil spill trajectory analysis

BOEM uses the OSRA model to estimate oil-spill trajectories and consider the likelihood of contact to important bird habitats. An ERA is a hypothetical polygon that represents a geographic area important to one or several bird species during a discrete amount of time. Given the wide variety of bird species that use the U.S. Beaufort Sea area and factoring in continuous changes in prey abundance and other biotic and abiotic factors that affect bird distribution, it is possible that large aggregations of some bird species could be contacted by a hypothetical VLOS. The ERAs are intended to define these areas and broad time periods of aggregation for the modeling effort. The ERA locations are described in Appendix A and Maps A-2a, A-2c, and A-2f. The ERAs important to birds, including the seasonal use patterns (i.e., vulnerabilities) of birds using the area, are summarized in Appendix A, Tables A.1-2 and A.1-5. Table 4.7.5-1 summarizes the results (expressed as a percentage of trajectories contacting) estimated by the OSRA model of a hypothetical VLOS contacting an ERA. Only probabilities equal to or greater than one percent are shown in the table.

According to the OSRA model, if a VLOS were to occur there is a substantial chance that the Sagavanirktok River Delta and Foggy Island Bay marine habitats (“ERA 77”) would be contacted. This ERA would face the greatest risk of all of the bird resource areas, with a 33% chance of a VLOS that is initiated at any time contacting it, and a 68% chance of contact should the VLOS occur in the summer.

Thousands of molting long-tailed ducks in the Foggy Island Bay-vicinity coastal lagoons would be at risk in July and August. The overall population of molting long-tail ducks in the adjacent coastal lagoon habitat can be in the tens of thousands, although the probability of VLOS contact of these adjacent ERAs falls considerably according to the OSRA, and given the large overall population of this species, it is unlikely that they would face population-level effects. Nonetheless, it is difficult to predict where the largest flocks of mobile birds may occur at any one time, and it is clear that large numbers of this species could be at risk at this time of year. Depending on season and bird movement in the local area, up to thousands of post-breeding king eiders may also perish.

A summer VLOS in Foggy Island Bay waters would also result in the direct mortality of breeding common eiders, red and red-necked phalaropes, glaucous gulls, geese, and lesser numbers of jaegers, swans, and loons. Breeding adults of all of these species that initially survive would also bring oil back to tundra and barrier island nests, contaminating and killing eggs and chicks.

On the Sagavanirktok River Delta, oil would threaten thousands of staging and migrating shorebirds and waterfowl, potentially representing a dozen or more bird species.

If a VLOS occurs, there are roughly equal probabilities that, should it travel beyond Foggy Island Bay, it would reach the coastal and barrier island ERAs that are adjacent in all directions. For a spill originating at any time of year, there is between a 4–7 % chance that it could reach the Gwyder Bay, West Dock, Cottle & Return Islands (72) to the east; Stockton and Melure (9), Midway, Cross, and Bartlett (96) Islands to the outside; and Mikkelsen Bay (78) to the east of Foggy Island Bay. For a summer VLOS, the probabilities that it would reach these surrounding areas are somewhat higher, between 8–14 %. While the OSRA model shows a noticeable drop in probabilities of VLOS contact of adjacent habitats that are just a few miles outside of Foggy Island Bay, contact is still possible in all directions, and could affect thousands of additional birds, even tens of thousands of molting long-tailed ducks and post-breeding king eiders and other waterfowl and seabirds in the marine lagoon habitat, and hundreds or even thousands of additional waterbirds including seabirds and loons, waterfowl, and shorebirds and their coastal or barrier island nests. The OSRA conditional probability model shows a 5% chance of a summer VLOS contact (2% annual) for the Colville River Delta ERA

(69), a critically important shorebird migration stopover site in both spring and fall. Tens of thousands of migrating shorebirds and waterfowl, including about 20 species and 20,000 dunlin (Andres, 1994; Bart et al., 2012; USGS, 2016), could be affected if a VLOS were to damage the Colville River Delta in July or later. New birds arriving and attempting to depart constantly during the post-breeding period from late June–October would increase the widespread nature of the impacts.

According to the OSRA model, if a VLOS were to occur it would remain almost entirely confined, even at 360 days, to the Beaufort Sea east of Point Barrow and west of Kaktovik. On an Alaska Arctic Coastal Plain scale, some of the most critical avian marine ecosystems include the river deltas/estuaries, barrier island/lagoon systems, and the Chukchi Sea spring lead system, including (seasonally) Peard Bay immediately west of Point Barrow. As described in the paragraphs above, if a VLOS were to occur there is up to a 68% chance that local portions of the first two ecosystem types (i.e., Sagavanirktok River Delta and Foggy Island Bay ERA) would be impacted. The highest chances of a VLOS, should one occur, contacting Peard Bay ERA (64) or the Chukchi Sea Spring Lead System ERA (19), on the other hand, are extremely low at 0.25% (summer trajectory launch) and 0.12% (winter trajectory launch), respectively (ERAs not listed in Table 4.7.5 1; pictured on Map A-2d).

Table 4.7.5-1. Conditional Probabilities for Bird ERA Contact 90 Days¹ after VLOS.

ID Number ²	Description	Annual Probability (%)	Summer Probability (%)
ERA 2	Point Barrow Plover Islands (between Point Barrow and Smith Bay)	1	2
ERA 5	Beaufort Sea Shelf Edge IBA (between Utqiagvik and Nuiqsut)	2	4
ERA 8	Maguire and Flaxman Islands	2	4
ERA 9	Stockton and Mclure Islands	6	10
ERA 65	Smith Bay	1	1
ERA 68	Harrison Bay	3	6
ERA 69	Harrison Bay/Colville Delta	2	5
ERA 71	Simpson Lagoon, Thetis and Jones Island	3	6
ERA 72	Gwyder Bay, West Dock, Cottle & Return Island	7	14
ERA 73	Prudhoe Bay	2	5
ERA 77	Sagavanirktok River Delta/Foggy Island Bay	33	68
ERA 78	Mikkelsen Bay	6	10
ERA 96	Midway, Cross and Bartlett Islands	4	8
ERA 124	Chukchi Sea Nearshore IBA	1	2
LS 105	Point Brower, Sagavanirktok River, Duck Island	29	33

Notes: ¹ Probabilities for all ERAs remain unchanged, with no additional ERAs with >1 after 360 days (see Tables A.2-6, A.2-24)

² ERA = Environmental Resource Area, LS = Land Segment

Sources: Appendix A Maps A-2a, A-2c, A-2f, A-3c; Tables A.2-5, A.2-23, A.2-11, A2-29

4.7.5.4. Conclusion

Based on conditional probabilities a VLOS starting at the proposed LDPI would threaten some important bird use areas, especially marine waters between barrier islands and the mainland, nearby barrier islands, and the Sagavanirktok River Delta. If Phase 1 occurred during the open-water season when birds are present, direct oiling of many species of birds and contamination of a significant portion of local food resources would occur. Many potentially affected bird species have large overall abundances or ranges well beyond the expected VLOS contact trajectories, and some, like geese species, have been increasing in their abundances. The migratory nature of Arctic bird life histories would generally mean that the VLOS impacts would be widespread, but the relative abundances would keep the impacts confined to minor or moderate levels for most species. However, a few populations which are relatively smaller, more locally confined, declining, and/or particularly vulnerable to oil contact or multiple impacts including climate change impacts, could potentially incur longer-lasting, even severe and therefore major, impacts. These could include non-listed

populations such as Beaufort Sea-breeding common eider, lesser snow goose and Sabine's gull, and buff-breasted sandpipers that move through Beaufort Sea coastal areas during migration.

ESA-listed spectacled eiders could experience moderate levels of impact across their ACP range. If one considers just that portion of the spectacled eider population that breeds on the Central Beaufort Sea coast, it is possible though not likely, due to their relatively dispersed breeding population, that this portion could experience a major level of impact. The listed population of Steller's eider rarely, or at low abundance and density, occurs in the expected extent of the trajectory of a hypothetical VLOS, and no more than a minor level of impact for that species would be expected.

In summary, effects from a VLOS could be expected to reach long-lasting and severe, and therefore major levels of impact for at least a few ACP populations of non-listed migratory birds, including, potentially, common eider, lesser snow geese, Sabine's gull, and buff-breasted sandpiper. A VLOS could have long-lasting and widespread, but less than severe, and therefore moderate impacts on numerous other ACP populations including ESA-listed spectacled eider, and non-listed phalaropes and other shorebirds, ice-associated gulls and other seabirds and loons.

Phase 1 and 2 impacts combined, including those from both a hypothetical VLOS associated with the Proposed Action and from spill response and cleanup activities, would also be major, varying with species and population. Spill response and recovery alone would contribute net negative impacts which would be additive with the existing minor to major Phase 1 impacts. The results would generally be only slightly higher levels of impact to the same species groups. Impacts from Phases 1, 2, and 3 combined would also continue to range up to major. As with Phase 1 alone, impacts would be minor for abundant species, and potentially major for ACP populations such as less-abundant or declining sea ducks and shorebirds using impacted shorezone, benthic, or local fish resources.

4.7.6. Effects of a VLOS on Marine Mammals

Impacts to marine mammals from a hypothetical oil spill were analyzed in Section 4.3.4. Those analyses found marine mammals could experience mortality, long-term and short-term sublethal impacts, and secondary impacts to prey availability. The primary difference between the effects from a VLOS and those of a large or small spill are in the greater magnitude of the potential effects associated with a VLOS. Most Environmental Resource Areas (ERAs), Land Segments (LSs), and Grouped Land Segments (GLSs) have less than a 5% probability of being contacted by any fraction of materials from a VLOS at the LDPI or the Pipeline. Based on the assumption that a $\leq 5\%$ probability of contact indicates a $\geq 95\%$ probability of no contact occurring, only those ERAs, LSs, and GLSs experiencing a $\geq 95\%$ contact probability are analyzed for marine mammals.

4.7.6.1. Cetaceans

A VLOS originating in the Proposed Action Area could affect cetaceans in a variety of ways. Population size, distribution and habitat selection are often species specific, putting different cetacean species at varying degrees of contact risk from a VLOS.

Effects of a VLOS on each cetacean species are analyzed below using the hypothetical scenario in section 4.5.3. One ESA-listed endangered whale (bowhead whale), and two other whale species (beluga and gray whales) occur in the Beaufort Sea. Additional cetacean species occurring in the Chukchi Sea include minke, killer whales, and harbor porpoise, as well as ESA-listed (endangered) fin and humpback whales.

When responding to a VLOS, response contractor(s) would work with NMFS, USCG, and state authorities on marine mammal management activities. In an actual spill, the aforementioned groups would likely have a presence at the Incident Command Post to review and approve proposed activities and monitor their impact on marine mammals. As a member of the team, NMFS personnel would be largely responsible for providing critical information affecting response activities to protect marine

mammals. Specific marine mammal protection activities would be employed as the situation requires and would be modified as needed to meet the current needs. In all cases long-term recovery to pre-spill abundance, distribution, and productivity is likely, but recovery period would vary, and require access to unaffected/restored habitat during the recovery period.

4.7.6.1.1. Initial Event

The hypothetical VLOS scenario would begin with a well-control incident resulting in a blowout and its immediate consequences. This phase would cause only negligible, temporary, non-lethal effects on cetaceans. This phase does not consider the release of oil or the effects of supporting aircraft or vessels; those will be analyzed in Phase 2 and Phase 4, respectively. Potential IPFs and associated effects on cetaceans from Phase 1 include the following:

Explosion

Materials released during a blowout could ignite, causing an explosion. An explosion from the island would create a single pulse sound event that could injure cetacean hearing, depending on sound levels. It is possible that any individual cetaceans within the vicinity could experience TTS or PTS. PTS would be considered a permanent injury, decreasing and individuals ability to successfully interact with their environment and, ultimately, leading to declining health and potential mortality. Bowhead and gray whales typically avoid waters in the vicinity of the LDPI as described in Section 3.2.4. Consequently, it is unlikely any individuals would be close enough to an explosion to experience TTS or PTS. Occasionally a few beluga whales may enter Stefansson Sound and under such circumstances could be exposed to the above ground noise from a blowout. The explosion would likely produce temporary non-lethal effects among belugas close to the LDPI, in the form of a startle response. Startle events (McCauley et al., 2000) may cause cetaceans to display short-term avoidance activity such as change of swim direction and/or speed that may be accompanied by short-term endocrine response.

4.7.6.1.2. Offshore Spill

Phase 2 of the scenario focuses on the continuing release of oil into offshore and nearshore waters. Of all the phases, the Offshore Spill has the greatest potential to affect cetaceans and their habitats. More severe impacts could also occur, and in some cases cetaceans may require three or more generations coincident with restored and unaffected habitat to restore distribution and populations.

Below are potential IPFs associated with Phase 2 that have the potential to affect cetaceans.

Contact with Oil

Cetaceans could experience effects from contact with hydrocarbons, including:

- Inhalation of liquid and gaseous toxic components of crude oil and gas
- Ingestion of oil and/or contaminated prey
- Fouling of baleen (bowhead, and gray whales)
- Oiling of skin, eyes, and conjunctive membranes causing corneal ulcers, conjunctivitis, swollen nictitating membranes and abrasions

Contamination

Impacts may include ingestion of contaminated prey (prey that have consumed or absorbed oil fractions that remain in their bodies) and/or reduction of food source. Pollution stemming from an oil spill may contaminate environmental resources, substrates (water, air, and sediments), habitat, and/or food sources. Contamination may also cause mortality and or contamination of food sources during the long term (multi-year) and short term (current-year production, ice and oceanographic cycles).

Loss of Access (Disturbance and Displacement)

Cetaceans may be displaced from feeding areas, migration routes, and other life function habitats. The latter include areas critical to the maintenance of individuals and populations, including birthing, feeding, breeding, migration, rearing/nursing, and resting. Moreover, whales may lose access to feeding areas or to areas where prey concentrate due to avoidance of spilled oil—displacement, or movement away.

This analysis will address each of these potential effects for each species of cetaceans using the Beaufort Sea.

Beluga Whale

Beluga whales of three different stocks use habitats from along the Alaska Beaufort and Chukchi Sea coastline seaward to beyond the shelf break. The distribution of these stocks are seasonal, wintering in the Bering Sea and migrating to summer habitats in the Canadian Beaufort, Alaskan Beaufort and Chukchi Seas (Suydam et al., 2001; Suydam, Lowry, and Frost, 2005; Roseneau, 2010). Some belugas migrate through the spring lead systems concurrent with the bowhead migration during April through June. Summer aggregations of molting belugas and females with calves occur in coastal lagoons and there is apparently habitat preference for waters near the continental shelf edge during summer and fall, particularly in the vicinity of Kasegaluk Lagoon.

Contact with Oil

Contamination of the spring ice lead system from a VLOS could result in direct contact with spilled oil. Notable increased vulnerability of belugas exists in spring and early summer, when concentrations occur in the warm shallow waters of Kasegaluk Lagoon to molt. Concentrations of large numbers of beluga whales are observed in some years in unpredictable places and numbers. In July of 2010, 650+ belugas were observed for a number of days in Elson Lagoon north of Utqiagvik (Monnett, 2010; NMFS, 2014c). Belugas are present in the Chukchi Sea and far western Beaufort Sea during the open-water season offshore as well as in coastal lagoons (Suydam et al., 2001; Suydam, Lowry, and Frost, 2005; and Ireland et al., 2009). Summer and fall observations indicate concentrations of belugas along and beyond the shelf edge, fall migration along the shelf edge, and some use throughout the shelf areas in the Chukchi and Beaufort Seas. There is acoustic evidence that some individuals may spend the winter period in the Alaska Arctic as well. They may, upon contacting spilled oil, experience inhalation, ingestion, skin and conjunctive tissue irritation similar to other whales, and also may exhibit detection and avoidance of spilled oil. Substantial injury and mortality due to physical contact inhalation and ingestion is possible to beluga whales, especially calves of the year and juveniles using habitats along the Alaska Chukchi Sea coast and the shallow lagoons situated there. Restoration of seasonal use patterns and abundance could take multiple generations and the potential for no recovery exists, depending on the extent of injury and mortality experienced. DFO (2010) indicates the factors and potential causes that may be hindering the recolonization of historic St. Lawrence beluga habitats after habitat degradation and loss of learned site fidelity through overharvest and extermination.

Ingestion

Beluga whales prey on fish (Arctic cod, saffron cod, herring, pollock) species as well as large copepods in the water column and on or near the surface, which may have spilled oil present. Consumption of contaminated prey, the reduction or mortality of local forage fish populations could create periods whereby summer prey would not be available for an undetermined time period depending on prey recovery rates and pioneering use of the restored prey. The fish populations in lagoons along the Chukchi Sea coast used by belugas for migration, molting and nursing are vulnerable to oil contamination and subsequent ingestion by large numbers of beluga whales (see the 2011 SEIS (Section IV.E.5)).

Oil components or chemical oil dispersant derived compounds could be consumed by belugas feeding on prey anywhere in contaminated water column layers to the sea floor. Belugas may ingest oil fractions from contaminated prey items. Ingestion of petroleum hydrocarbons can lead to subtle and progressive organ damage or to rapid death in mammals. Many polycyclic aromatic hydrocarbons are teratogenic and embryo toxic in at least some mammals (Khan et al., 1987). Maternal exposure to crude oil during pregnancy may negatively impact the birth weight of young. Oil ingestion can decrease food assimilation of prey eaten (St. Aubin, 1988). Decreased food assimilation could be particularly important in very young animals, those that seasonally feed, and those that need to put on high levels of fat to survive their environment. Wilson et al. (2005) examined CYP1A1 protein expression immunohistochemically in multiple organs of beluga whales from two locations in the Arctic and from the St. Lawrence estuary. These beluga populations have some of the lowest (Arctic sites) and highest (St. Lawrence estuary) concentrations of PCBs in blubber of all cetaceans. Cytochrome P450 1A1 (CYP1A1) is induced by exposure to polycyclic aromatic hydrocarbons (PAHs) and planar halogenated aromatic hydrocarbons (PHAHs) such as non-ortho polychlorinated biphenyls (PCBs). The systemic high-level expression of CYP1A1 in Arctic beluga suggests that effects of PAHs or PHAHs may be expected in Arctic populations. The high-level expression of CYP1A1 in the Arctic beluga suggests that this species is highly sensitive to CYP1A1 induction by aryl hydrocarbon receptor agonists. Samples from these populations might be expected to have different contaminant-induced responses, reflecting their different exposure histories. The pattern and extent of CYP1A1 staining in whales from all three locations were similar to those seen in animal models in which CYP1A has been highly induced, indicating a high-level expression in these whales. CYP1A1 induction has been related to toxic effects of PHAHs or PAHs in some species. The systemic high-level expression of CYP1A1 in Arctic beluga suggests that effects of PAHs or PHAHs may be expected in Arctic populations, as well. The high-level expression of CYP1A1 in the Arctic beluga suggests that this species is highly sensitive to CYP1A1 induction by aryl hydrocarbon receptor agonists.

Contamination and Reduction of Food Sources

Abundance and distribution may be modified or reduced in near shore areas in response to prey (fish and large copepods) reduction and contamination resulting from a VLOS. Prey recovery periods would determine recovery periods for beluga whale distribution and abundance to pre-spill levels (see the 2011 SEIS (Section IV.E.5)).

Displacement From and Avoidance of Habitat

The presence of oil could displace belugas from, or prevent or disrupt access to affected habitat areas. The loss of nearshore and lagoon habitats by beluga females with calves and juveniles for nursing and molting, depending upon the extent of injury or mortality experienced may not be recoverable or take multiple generations to recover the use and abundance of whales using these seasonally important habitats. Impacts to the distribution and abundance of prey, if they should occur, would largely determine the seasonal distribution and habitat use by belugas.

Bowhead Whale (Endangered)

Bowhead whales migrate in spring through the Chukchi Sea to summer feeding areas in the Beaufort Sea, and in fall to the Bering Sea wintering area with a relatively small number possibly staying in the Chukchi Sea throughout the summer (Moore and Reeves, 1993, Brueggeman et al., 1992). The spring migration is well documented with whales following the open leads in the sea ice running parallel to the Chukchi Sea coastline before veering eastward through the Beaufort Sea (Braham, Krogman, and Carroll, 1984; Moore and Reeves, 1993). Most whales pass through the Chukchi Sea by late June, and migration is occurring earlier than in the past according to traditional environmental knowledge (TEK) and research (Huntington and Quakenbush, 2009).

Since 2006, the fall migration has been more specifically documented by tracking 20 satellite-tagged bowhead whales from Utqiagvik through the Chukchi Sea into the Bering Sea (Quakenbush et al., 2009). Most of the whales migrated westward above 71° N latitude from Utqiagvik to Wrangel Island and then down the Chukotka Coast before entering the Bering Sea. Some whales apparently migrated in a more southwesterly direction from Utqiagvik to the Chukotka Coast, crossing through or near the Proposed Action Area (Quakenbush, Small, and Citta, 2010). Aerial and vessel surveys conducted in the Chukchi Sea in the 1980s and 1990s also suggest a southwesterly route based on scattered bowhead whale sighting locations (Ljungblad and Van Schoik, 1982, 1986, 1987; Brueggeman et al., 1991, 1992). Recent acoustic studies conducted from 2007 to 2009 indicated calling bowheads migrated across the Chukchi Sea in both a westerly direction following the 71° N latitude and a less defined route after leaving the Utqiagvik area (Hannay et al., 2009; Martin et al., 2008). Eskimo whalers report whales travel westward and later during light ice years and southwestward during heavy ice years (Huntington and Quakenbush, 2009, Figure 26). These collective results suggest the location of the fall migration route may comprise a variety of paths dispersed widely across the Chukchi Sea. The fall migration of bowheads through the Chukchi Sea generally begins in early October and ends sometime in December, as sea ice advances into the Bering Sea. Clarke et al. (2014) noted bowhead whale feeding areas in the Canadian Beaufort Sea, and Rugh et al. (2014) observed bowhead feeding areas in the vicinity of Barrow Canyon and Utqiagvik, Alaska. As summer begins to end, bowheads commence migrating from the Eastern Beaufort Sea to an aggregation and feeding area north of Utqiagvik. From there they usually begin crossing the Chukchi Sea in mid to late September and continue the out-migration from the Beaufort Sea thru November.

Contact with Oil

Bowheads are the most likely ESA-listed whale to experience effects of a VLOS as described in the Scenario, as they are common in the Chukchi and Beaufort Sea waters during their migrations (Harwood et al., 2010; Quakenbush, Small, and Citta, 2010). Acoustic studies suggest some bowheads inhabit the Chukchi Sea year-round; however, most bowheads spend their summer feeding in the Beaufort Sea before migrating to the Bering Sea to overwinter (Moore et al., 2010). Calling bowheads have been recorded in the Chukchi Sea during summer and winter (Berchok et al., 2009, Funk et al., 2010; Moore et al., 2010).

Nothing suggests the effects in the hypothetical scenario would differ between the alternatives. Additional information on bowhead presence in the western Beaufort Sea and northeastern Chukchi Sea from December through March is not essential to a reasoned choice among the alternatives.

There are few post-spill studies with sufficient details to reach firm conclusions about the effects, especially the long-term effects, of an oil spill on free-ranging populations of marine mammals, including bowhead whales. Given the very low probability of a VLOS event occurring and affecting large numbers of cetaceans, and the fact that the overall potential for impacts would vary only slightly under each action alternative, additional studies on the potential effects of oil exposure on free-ranging marine mammal populations is not essential to a reasoned choice among alternatives. Nonetheless, evaluation of available science permits the application of scientific judgment regarding potential effects.

Available evidence suggests that mammalian species vary in their vulnerability to short-term damage from surface contact with oil and ingestion. While vulnerability to oil contamination exists due to ecological and physiological reasons, species also vary greatly in the amount of information that has been collected about them and about their potential oil vulnerability. These facts are linked, because the most vulnerable species have received the most focused studies. However, it also is the case that it is more difficult to obtain detailed information on the health, development, reproduction and survival of large cetaceans than on some other marine mammals. The logistical, physical capability, technology and cost limitations that would provide data collection and evaluation of the potential for

long-term sublethal effects on large cetaceans are prohibitive at this time. On the other hand, it may be that ecological and physiological characteristics specific to large cetaceans serve to buffer them from many of those same types of impacts. Unless impacts are large and whales die and are necropsied, most effects must be measured primarily using tools of observation. Unless baseline data are exceptionally good, determination of an effect is only possible if the effect is dramatic.

With whales, even when unusual changes in abundance occur following an event such as the *Exxon Valdez* Oil Spill (as with the disappearance of relatively large numbers of killer whales from the AB pod in Prince William Sound) (see Dahlheim and Matkin, 1994 and the following discussion), interpretation of the data varies and is controversial due to lack of carcasses for necropsy. Thus, predicting potential long-term sublethal effects (reduced body condition/ health/ productivity/fitness, etc.) or lethal effects on cetaceans from a VLOS is problematic.

The greatest threat to large cetaceans would be inhalation of fresh oil toxic hydrocarbons fractions. Prolonged inhalation of volatile toxic hydrocarbon fractions of fresh oil induces severe effects.

Inhalation of volatile hydrocarbon fractions of fresh crude oil can damage the respiratory system (Hansen, 1985; Neff, 1990), cause neurological disorders or liver damage (Geraci and St. Aubin, 1982), have anesthetic effects (Neff, 1990) and, if accompanied by excessive adrenalin release, cause sudden death (Geraci, 1988). Bowhead mortality could occur if they surfaced and breathed repeatedly in the fresh oil of a VLOS and freshly evaporated toxic aromatic hydrocarbon compound vapors occur at the sea surface. Effects upon bowhead whales range from negligible to acute toxic poisoning resulting in endocrine system and organ impairment or death. Lighter-than-air aromatic vapors dissipate rapidly into the atmosphere. Heavier than air components may linger near the surface during periods of calm winds, but otherwise atmospheric mixing allows these vapors to dissipate rapidly.

The dissipation of volatile components varies with temperature, wind, and characteristics of encapsulation of oil components into ice and the ice conditions that determine rate of release. Oil trapped in the mixed and fractured ice and interspersed open-water characteristic of polynya systems allows for varying amounts of toxic aromatic components to evaporate and dissipate during the winter period before migrating bowheads arrive in the Chukchi Sea spring lead system. Spilled oil that has aged to the point where initial evaporation of light toxic fumes is no longer present reduces the risk of prolonged inhalation exposure to toxic fumes.

Two situations of higher risk to bowhead whales could occur. These exceptions involve prolonged exposure of migrating or feeding bowheads to inhalation of volatile toxic components of fresh oil in the Chukchi Sea spring lead system during migration of the majority of the Western Arctic Bowhead population through the lead system and when feeding aggregations (such as those that occur northeast of Utqiagvik in the fall) are similarly exposed to toxic fumes from a VLOS. During spring migration, females with newborn calves, whose movement is somewhat constrained by the polynya system, may endure exposure to some released toxic fumes from fresh oil trapped in ice between October 31 of the previous year to about January 4. It is likely that a major portion of the toxic fumes would have evaporated over the winter through the active cracks, ice movement, and movement through brine channels in the polynya ice cover when temperatures are at or above critical temperature (NORCOR, 1975; Fingas and Hollebone, 2003). Toxic fumes are likely to have dispersed in the atmosphere by May and early June, when most females with calves migrate through the Chukchi Sea spring lead system, and would not pose a prolonged toxic exposure. If high toxic vapor levels should occur and prolonged exposure of females with calves occurs, mortality could result. Volatile toxic fractions may be particularly toxic to newborn calves that must take more frequent breaths and spend more time at the surface than their mothers. As unlikely as it may seem, such exposure is not beyond the range of possibilities, and depending on the timing and numbers of females with calves contacting toxic vapors of fresh oil, mortality of a large portion of a year's cohort of calves and perhaps some individual females and other age and sex classes could occur.

Options to migrate through adjacent ice covered waters are fewer for newborns as compared to older animals that may or may not be able to detect the spill and exercise alternate migration routing options. These adults may travel through considerable areas of up to 100% ice cover, which appears to not limit bowhead distribution (Quakenbush, Small, and Citta, 2010). There are anatomical data and observations that bowhead whales have the olfactory organs (Thewissen et al., 2010) and ability to detect smoke from dumps and potentially spilled oil such that they may modify movements to avoid a large or VLOS. Spring migration could be delayed or deflected around spilled oil (females with calves, and other age and sex classes, may attempt to detour through adjacent ice covered waters around the spill and associated toxic fumes). Newborn calves—having short breathing intervals and less capability to break breathing spaces in ice cover while following their mothers—risk separation, abandonment or mortality. A portion of an annual cohort of newborn calves and some older individuals could potentially experience such mortality under those conditions. Depending on numbers of calves that might die, loss of an annual cohort would be reflected in an immediate reduction in population that may take several years to replace. Also, there may be in the future reduced contribution of the individual females and their progeny to recruitment into the breeding female population (these females would have become sexually mature in 18-20 years). The loss of the lifetime reproductive contribution of these females to the population could depress population rate of increase slightly for several decades.

Another circumstance whereby effects could be experienced by large numbers of bowheads is when one or more large aggregations of bowheads contact a fresh oil spill (with high concentrations of toxic aromatic vapors) during the open-water season. Aggregations of between 50 and 100 bowheads have been observed in some, but not all years, during BOEM and NMFS aerial surveys and particularly in the feeding area identified northeast of Utqiaġvik under bowhead feeding studies (Moore, George, and Sheffield et al., 2010).

Spilled oil appears to have limited impact on cetacean skin. In a study on nonbaleen whales and other cetaceans, Harvey and Dahlheim (1994) observed 80 Dall's porpoises, 18 killer whales, and 2 harbor porpoises in oil on the water's surface from the Exxon Valdez Oil Spill (EVOS). They observed groups of Dall's porpoises on 21 occasions in areas with light sheen, several occasions in areas with moderate-to-heavy surface oil, once in no oil, and once when they did not record the amount of oil. Thirteen of the animals were close enough to determine if oil was present on their skin. They confirmed that 12 animals in light sheen or moderate-to-heavy oil did not have oil on their skin. The 18 killer whales and 2 harbor porpoises were in oil but had none on their skin. None of the cetaceans appeared to alter their behaviors when in areas where oil was present. The authors concluded their observations were consistent with other reports of cetaceans behaving normally when oil is present. Some temporary irritation or permanent damage to conjunctive tissues, mucous membranes, around the eyes, abrasions, conjunctivitis and swollen nictitating membranes could occur (Geraci and Smith, 1976b; Davis, Schafer, and Bell, 1960).

Ingestion

Ingestion of dissolved, suspended, or floating oil components while feeding on or near the surface could occur during the open-water period, or if bowheads come into contact with oil in/on the seafloor during near-bottom feeding. Oil components or chemical oil dispersant derived compounds could be consumed by bowheads feeding on prey anywhere in contaminated water column layers to the sea floor. Bowheads may ingest oil fractions that sink to (and may persist in) the seafloor sediments that are disturbed when near-bottom feeding. Ingestion of petroleum hydrocarbons can lead to subtle and progressive organ damage or to rapid death in mammals. Many polycyclic aromatic hydrocarbons are teratogenic and embryotoxic in at least some mammals (Khan et al., 1987).

Maternal exposure to crude oil during pregnancy may negatively impact the birth weight of young. While the potential effects on bowhead to exposure to PAHs through their food are largely unknown,

the very low probability of a VLOS event occurring and leading to widespread ingestion of PAHs, and the fact that the potential for such impacts would vary only slightly under each action alternative, means that additional studies of this potential are not essential to a reasoned choice among alternatives. That said, there currently exists information with pertinence to this issue. Oil ingestion can decrease food assimilation of prey eaten (for example, St. Aubin, 1988). Decreased food assimilation could be particularly important in very young animals, those that seasonally feed, and those that need to put on high levels of fat to survive their environment. Because of their extreme longevity, bowheads are vulnerable to long-term accumulation of pollutants. With increasing development within their range and long-distance transport of other pollutants, individual bowheads may experience multiple large and small polluting events within their lifetime. Tissue studies by Geraci and St. Aubin (1990) revealed low levels of naphthalene in the livers and blubber of baleen whales. This result suggests that prey have low concentrations in their tissues, or that baleen whales may be able to metabolize and excrete certain petroleum hydrocarbons.

Temporary baleen fouling could also occur, but the light weight of the spilled oil probable for the Beaufort Sea makes it less likely to adhere to and impair the hydraulic function of the baleen fibers as would more viscous, weathered or emulsified oil. Lighter oil should result in less interference with feeding efficiency. In a study in which baleen from fin, sei, humpback, and gray whales was oiled, Geraci (1988) found that 70% of the oil adhering to baleen plates was lost within 30 minutes (Geraci, 1990), and in 8 of 11 trials, more than 95% of the oil was cleared after 24 hours. The study could not detect any change in resistance to water flowing through baleen after 24 hours. The baleen from these whales is shorter, and in some cases finer, than that of bowhead whales, whose longer baleen has many hairlike filaments. Lambertsen et al. (2005, p. 350) concluded that results of their studies indicate that Geraci's analysis of physiologic effects of oiling on mysticete baleen "considered baleen function to be powered solely by hydraulic pressure," a perspective they characterized as a "gross oversimplification of the relevant physiology." A reduction in food caught in the baleen could have an effect on the body condition and health of affected whales. If such an effect lasted for 30 days, as suggested by the experiments of Braithwaite (1983), this could potentially be an effect that lasted a substantial proportion of the period that bowheads spend on the summer feeding grounds. Repeated baleen fouling over a long time, however, might also reduce food intake and blubber deposition, which could harm the bowheads. Geraci (1990) also pointed out the greatest potential for effects on bowheads would be if spilled oil occurred in the spring lead system.

Contamination and Reduction of Food Sources

Data from a recent study (Duesterloh, Short, and Barron, 2002) indicated that aqueous polyaromatic compounds (PACs) dissolved from weathered Alaska North Slope crude oil are phototoxic to subarctic marine copepods at PAC concentrations that would likely result from an oil spill and at UV levels that are encountered in nature. *Calanus marshallae* exposed to UV in natural sunlight and low doses (~2 micrograms (μg) of total PAC per liter of the water soluble fraction of weathered North Slope crude oil for 24 hours) showed an 80-100% morbidity and mortality as compared to less than 10% with exposure to the oil-only or sun-light only treatments. One hundred percent mortality occurred in *Metridia okhotensis* with the oil and UV treatment, while only 5% mortality occurred with the oil treatment alone. Duesterloh, Short, and Barron (2002) reported that phototoxic concentrations to some copepod species were lower by a factor of 23 to >4,000 than the lethal concentrations of total PAC alone (0.05-9.4 mg/L).

This research also indicated that copepods may passively accumulate PACs from water and could thereby serve as a conduit for the transfer of PAC to higher trophic level consumers. Bioaccumulation factors were ~2,000 for *M. okhotensis* and about ~8,000 for *C. marshallae*. *Calanus* and *Neocalanus* copepods have relatively higher bioaccumulation than many other species of copepods because of their characteristically high lipid content. The authors concluded that phototoxic effects on copepods could conceivably cause ecosystem disruptions that have not been accounted for in traditional oil spill

damage assessments. Particularly in nearshore habitats where vertical migration of copepods is inhibited due to shallow depths and geographical enclosure, phototoxicity could cause mass mortality in the local plankton population (Duesterloh, Short, and Barron, 2002, p. 3959).

The potential effects on bowheads of exposure to PACs through their food remain undocumented; however, bowhead whales may swallow some oil-contaminated prey and ingest some dissolved or floating oil fractions incidental to food intake, but it likely would be only a small part of their food. Bowhead whales may or may not leave a feeding area where prey was abundant following a VLOS. Some zooplankton, which are eaten by bowheads, consume contaminated oil particles contained in their prey. Tissue studies by Geraci and St. Aubin (1990) revealed low levels of naphthalene in the livers and blubber of baleen whales. This result suggests that prey have low concentrations in their tissues, or that baleen whales may be able to metabolize and excrete certain petroleum hydrocarbons. The probability that a VLOS would occur and affect bowhead whales through exposure to PACs or displacement from productive feeding areas is very small, and would vary only slightly under each action alternative. Additional information on these subjects is therefore not essential for a reasoned choice among alternatives.

A VLOS probably would not permanently affect zooplankton populations, the bowhead's major food source, and major effects are most likely to occur nearshore (Richardson et al., 1987, as cited in Bratton et al., 1993). The amount of zooplankton lost in a VLOS could be very small compared to what is available on the whales' summer-feeding grounds (Bratton et al., 1993). A VLOS, depending on the timing and location relative to the distribution and aggregations of zooplankton, could reduce feeding opportunities for a majority of the bowhead population during that year. The significance of the loss of that opportunity to bowhead health is dependent upon major feeding opportunities bowheads may find later in the year to meet annual energy demands. Fate, recovery, and availability of zooplankton populations to bowheads in similar quantities and locations as pre-spill conditions in the Chukchi and western Beaufort Seas in subsequent years would depend on a variety of factors, as is analyzed in the 2011 SEIS (Section IV.E.4). Oceanographic and climatic factors combine to aggregate zooplankton in some areas. Sources, transport of, and year to year persistence of plankton populations utilized by bowhead whales in and adjacent to the Proposed Action Area remain unclear.

While controlled studies of the potential effects on bowheads of exposure to PACs through their food remain infeasible at this time, bowheads are believed to be vulnerable to long-term accumulation of pollutants given their extreme longevity. With increasing development within their range and long-distance transport of other pollutants, individual bowheads may experience multiple large and small polluting events, as well as chronic pollution exposure, within their lifetime.

Displacement From and Avoidance of Habitat

Scientists have not had the opportunity to observe bowhead response to a VLOS, nor any displacement caused by subsequent spill response and cleanup operations. However, there are first-hand accounts of displacement effects on bowhead whales from a 25,000-gallon (595-bbl) oil spill at Elson Lagoon (Plover Islands) in 1944. Traditional knowledge provided by Brower (1980) explained that for the four years that oil was still present, bowhead whales made a wide detour out to sea when passing near Elson Lagoon/Plover Islands during fall migration. Bowhead whales normally moved close to these islands during the fall migration (when no oil was present). These observations indicate that some displacement of whales may occur in the event of a VLOS, and that the displacement may last for several years. Based on these observations, it also appears that bowhead whales may have some ability to detect an oil spill and avoid surfacing in the oil by detouring around the area of the spill. Anatomical data and observations that suggest bowhead whales have well-developed olfactory organs (Thewissen et al., 2010), and could detect spilled oil to such a degree that they may modify movements to avoid a VLOS.

Other investigators have observed various cetaceans in spilled oil, including fin whales, humpback whales, gray whales, dolphins, and pilot whales. Typically, the whales did not avoid slicks but swam through them, apparently showing no reaction to the oil. During the spill of Bunker C and No. 2 fuel oil from the *Regal Sword*, researchers saw humpback and fin whales, and a whale tentatively identified as a right whale, surfacing and even feeding in or near an oil slick off Cape Cod, Massachusetts (Geraci and St. Aubin, 1990). Whales and a large number of white-sided dolphins swam, played, and fed in and near the slicks. The study reported no difference in behavior between cetaceans within the slick and those beyond it. None of these observations are sufficient to prove cetaceans can detect oil and avoid it, or if long-term impacts occurred from exposure. Some researchers have concluded that baleen whales have such good surface vision that they rely on visual clues for orientation in various activities. In particular, bowhead whales have been seen “playing” with floating logs and sheens of fluorescent dye on the sea surface of the sea (Würsig et al., 1985, as cited in Bratton et al., 1993; Clarke et al., 2014). Such observations suggest oil present on the sea surface in recognizable quality or quantity may be recognizable and avoidable by bowhead whales (Bratton et al., 1993). However, the observation of their playing with dye could also indicate inability to avoid spilled oil.

After the EVOS, researchers studied the potential effects of an oil spill on cetaceans. Dahlheim and Loughlin (1990) documented negligible levels of effect on the humpback whale. Von Ziegesar, Miller, and Dahlheim (1994) found no indication of a change in abundance, calving rates, seasonal residency time of female-calf pairs, or mortality in humpback whales as a result of that spill, although they did see temporary displacement from some areas of Prince William Sound.

The presence of oil could prevent or disrupt access to and displace whales from habitat areas. Depending on oceanographic and climatic variables, zooplankton food concentrations that may normally result in feeding aggregations of bowhead whales may not be available. A VLOS could displace feeding whales from an active feeding event(s) or cause whales to avoid an otherwise available aggregated food source and feeding opportunity. Depending on the specifics and magnitude of a lost feeding opportunity and its contribution to the annual energy and nutrient requirement of individual whales, effects upon health and reproduction could occur. Situations where effects could be more important include impaired access to the relatively consistent food aggregations northeast of Point Barrow and any large aggregations of food attracting and holding large numbers of whales for an extended period of time (from a few days to weeks). Loss of access and use of the spring polynya system by migrating bowhead and beluga whales could result in variable mortality of newborn bowhead calves, delayed migration, and/or migration route avoidance or deflection and redistribution of migrating and spring feeding whales to adjacent areas with greater ice cover. Depending on the specifics of a given event, mortality of a portion of an annual cohort of calves could result, which in turn could have longer term effects on population level recruitment and reproduction. It could also result in modification of migration pattern effects, as well as shorter term body condition and health effects.

In most cases, a VLOS event would occur at a time of year when the toxic fumes would dissipate into the atmosphere rapidly so as not to allow for prolonged exposure to the majority of whales in the open-water and fall migration period. There is a potential that spilled oil could persist and be transported during ice covered seasons. A portion of the toxic volatile hydrocarbon fractions are likely to evaporate and dissipate into the atmosphere before remaining oil could be contacted by migrating bowheads during the next year. Thus, toxic fractions would occur in low enough densities to disallow prolonged (if any) exposure for cetaceans in the spring lead system. The northernmost portions of the spring lead system appear to be used by some spring migrating bowheads in the Chukchi Sea where contact with freshly spilled oil and fumes due to the shorter distance to an event site and shorter period that fresh oil has to age in the lead system could occur. There may be an opportunity for the individuals that have migration paths in those areas to be much closer to potential

spill sites on existing leases, and they could be exposed to prolonged inhalation of toxic fumes if they do not exercise detection and avoidance responses. The potential for major impacts to an annual cohort of the bowhead population could occur under a narrow set of conditional circumstances during the spring migration through the spring lead system in the Chukchi Sea and the far western Beaufort Sea.

Gray Whale

Gray whales mostly summer in the Chukchi Sea where they feed before returning to wintering grounds in Mexico (Rugh et al., 1999; Rugh, Shelden, and Schulman-Jainger, 2001; Roseneau, 2010); however, they also occur in the Beaufort Sea in lower numbers. They occupy Arctic waters during the open-water season, generally arriving behind the retreat of the sea ice and leaving ahead of the early winter sea ice formation (Clarke, Moore, and Ljungblad, 1989; Brueggeman et al., 1992; Funk et al., 2010; Goetz et al., 2009). They are the most abundant cetacean reported in the Chukchi Sea during summer (Funk et al., 2010; Brueggeman et al., 1992) and widespread. Gray whales typically use nearshore habitat (<40 km or 25 mi from shore) with highest concentrations north and east of Wainwright, and most sightings occurred between Wainwright and Cape Belcher during the 2008 and 2009 survey seasons (Brueggeman, 2010). More recent ASAMM sighting data in Clarke et al. (2014) supports the earlier surveys, indicating large gray whale concentration areas from Wainwright to Utqiagvik in nearshore waters.

Recent acoustic data suggest some gray whales may over-winter in the Chukchi Sea (Stafford et al., 2007), but the numbers are likely small (Moore, DeMaster, and Dayton, 2000). Gray whales observed during a shallow hazards survey conducted by ConocoPhillips at Klondike Prospect area and a coring program between Klondike and the coast in 2008 were entirely nearshore (Brueggeman et al., 2009b) and 2009-2010 COMIDA surveys (COMIDA, 2009; 2010) found most gray whales feeding nearshore between Point Lay and Point Barrow from June to October.

Rugh et al. (2014) noted gray whales feeding in the vicinity of Barrow Canyon, with some individuals feeding to the west of Point Barrow, Alaska.

Gray whale movements vary annually depending on prey abundance and distribution (Nerini, 1984). Gray whales feed in soft sediments which support their primary prey: benthic ampeliscid amphipods (Nerini, 1984). Smaller numbers of gray whales historically concentrated in the region of Hanna Shoal, north and east of the Proposed Action Area between 160° and 165° W, but none were seen there during the 2009 and 2010 COMIDA surveys (Clarke et al., 2011c); however, two were seen in the vicinity of Hanna Shoal during ASAMM surveys suggesting a few gray whales still frequent the Hanna Shoal area (Clarke et al. 2014).

Contact with Oil

Gray whales are present in the Chukchi Sea and far western and eastern Beaufort Sea (Rugh, 1981; Moore, DeMaster, and Dayton, 2000) during the open-water season, but there is acoustic evidence that individuals may spend the winter period in the Alaska Arctic as well (Stafford et al., 2007).

These whales occur in shallow shelf nearshore and offshore shoal habitats to feed on benthic prey. They may, upon contacting spilled oil, experience effects from inhalation, ingestion, baleen fouling, skin and conjunctive tissue irritation, but also may exhibit detection and avoidance of spilled oil similar to whale species analyzed earlier. Migrating gray whales show only partial avoidance to natural oil seeps off California.

Laboratory tests suggest gray whale baleen, and possibly skin, may be resistant to oil damage. Gray whales exhibiting abnormal behavior were observed in oil after the EVOS in an area where fumes from the spill were very strong (J. Lentfer as cited in Harvey and Dalheim, 1994). Subsequently, large numbers of gray whale carcasses were discovered. One of three of these had elevated levels of PAHs

in its blubber. Loughlin (1994) concluded it was unclear what caused the death of the gray whales. An estimated 80,000 barrels of oil may have entered the marine environment off Santa Barbara in 1969, when gray whales were beginning the annual migration north. Whales were observed migrating through the slick. Subsequently, six dead gray whales were observed and recovered as well as a number of other marine mammals. No evidence of oil contamination was found on any of these whales. The Battelle Memorial Institute concluded the whales were either able to avoid the oil, or were unaffected when in contact with it. Based on all available information, if individual, small or large groups of gray whales were exposed to large amounts of fresh oil from a VLOS, especially through inhalation of highly toxic aromatic fractions, they might be seriously injured or die from such exposure. Although there is little definitive evidence linking cetacean death and serious injury to oil exposure, the deaths of large numbers of gray whales coincided with EVOS and observations of gray whales in oil. If fresh oil from a VLOS contacted important coastal or shoal habitats, the gray whale population could be at risk for multiple cases of injury or mortality when concentrated on summer feeding grounds, and could have limited options to avoid a spill and still meet annual nutrient and energy requirements in the Chukchi Sea.

Recovery of distribution, abundance, and habitats may take decades to recover or possibly more than three generations.

Ingestion

Gray whales may ingest oil fractions that sink to (and may persist in) the seafloor sediments that are disturbed when bottom feeding on benthic invertebrates, as is characteristic of the gray whale.

Chronic consumption of bottom accrued oil fractions or contaminated prey may result in impaired endocrine function, reproductive impairment, or mortality. Baleen whales may have the capability to metabolize ingested oil compounds.

Contamination and Reduction of Food Sources

In the Chukchi Sea, spilled oil could affect gray whales by contaminating benthic prey and sediments (please refer to the 2011 SEIS (Section IV.E.4)), particularly in prime feeding areas (Würsig, 1990; Moore and Clark, 2002). Any perturbation, such as a VLOS, which caused extensive mortality within a high latitude amphipod population with low fecundity and long generation times would result in marked decreases in secondary production (Highsmith and Coyle, 1992). For example, populations of amphipods off the coast of France were reduced by 99.3% following the *Amoco Cadis* oil spill in 1978 (approximately 70 million gallons). Ten years after the spill, amphipod populations had recovered to 39% of their original maximum densities (Dauvin, 1989, as cited by Highsmith and Coyle, 1992). Chukchi Sea amphipod populations with longer generation times and lower growth rates, probably would take considerably longer to recover from any major population disruption (Highsmith and Coyle, 1992).

Displacement From and Avoidance of Habitat

Reduction or mortality in benthic prey larval stages that live in the water column, reduced benthic biomass, and productivity of nearshore and offshore shoals may force gray whales to seek alternate, less optimal foraging areas of the shelf offshore for up to several years until nearshore or shoal benthic communities recover. Impacts to these whales could occur over a period of years depending on numbers and amounts of oil fractions chronically consumed or reduced from a VLOS and the quality and availability of alternate feeding habitat in the Alaska Arctic. Restoration of distribution and abundance of gray whales along the Alaska Chukchi Sea coast could take more than three generations to recover from a VLOS.

Fin Whale (Endangered)

Fin whales are present during the open-water season in the Chukchi Sea, (Funk et al., 2010; COMIDA, 2009; Roseneau, 2010), and are more common in the southwestern Chukchi Sea near Chukotka, Russia. They are widespread and more abundant in the Bering Sea (Melinger et al., 2010), but have never been documented in the Beaufort Sea. Their similarities to bowhead whales suggest they should experience effects similar to bowheads from VLOS exposure if a VLOS from the Proposed Action Area entered the Chukchi Sea. It is even possible that fin whales could be killed if they surfaced repeatedly in the midst of a large, fresh oil slick and inhaled high concentrations of volatile components of crude oil. Likewise, fin whales could exhibit the ability to detect and avoid spilled oil for the same reasons bowhead whales might. Available data following both the EVOS and the Glacier Bay, Alaska oil spills indicate it is unlikely large numbers of fin whales would be affected by a VLOS from the Proposed Action Area.

Because of their frequency of occurrence and distribution in the Chukchi Sea the primary areas for effect of a VLOS on fin whales would occur in the waters of the Chukchi Sea off Chukotka, especially near Cape Dezhnev in the summer, or in waters south of Cape Lisburne, Alaska.

Humpback Whale (Endangered)

Humpback whales are present during the open-water season in Chukchi Sea coastal waters and the far western Beaufort Sea (Clarke et al., 2014), but have not been observed near the Proposed Action Area. The nearest observations of humpback whales to the Proposed Action Area occurred approximately 400 km (250 mi) to the west of the Area (Hashagen et al., 2009). They are regularly observed in waters of the southwestern Chukchi Sea adjacent to the Chukotka Peninsula, south of Cape Lisburne, and occasionally in Peard Bay, Alaska. Because they are also baleen whales they may, upon contacting spilled oil, experience similar inhalation, ingestion, baleen fouling, skin and conjunctive tissue irritation; but also may exhibit detection and avoidance of spilled oil as may bowhead and fin whales. Repeated surfacing within a VLOS with fresh oil with high levels of volatile toxic hydrocarbon fractions present could potentially lead to organ damage and/or mortality of humpbacks. These whales prey on schools of forage fish (capelin, sand lance, herring) species as well as copepods and euphausiids in the water column and on or near the surface which may have spilled oil present. Potential reduction or mortality of local forage fish populations could create periods whereby summer prey would not be available for an undetermined time period depending on prey recovery rates and pioneering use of the restored prey. A negligible number of the Central North Pacific population of humpback whales would be expected to experience temporary and non-lethal effects from a VLOS within the Proposed Action Area. However, if the humpback whales in the Proposed Action Area and adjacent Chukchi Sea originate from the Western North Pacific stock (a smaller and less well-understood stock), any injuries or losses of individuals could produce important population level effects. Under such circumstances, three or more generations could be required to re-establish distribution and abundance in the Alaska Chukchi and Beaufort Seas.

Studying the EVOS, von Ziegesar, Miller, and Dahlheim (1994) found no indication of a change in abundance, calving rates, seasonal residency time of female-calf pairs, or mortality in humpback whales as a result of that spill, although they did see temporary displacement from some areas of Prince William Sound. As analyzed in previous paragraphs, literature on the effects of crude oil on mammals indicates humpback whales could be vulnerable to such spills.

Because of their scarcity and distribution, the greatest effects on humpback whales would be from a VLOS contacting Chukchi Sea waters adjacent to the Chukotka Peninsula, or south of Cape Lisburne, Alaska. In summer and fall, humpback whales could be negatively affected by a VLOS contacting waters off the northern Chukotkan coastline, especially near Cape Dezhnev. Because of the increasing length of the open-water season, increases in humpback whale numbers and use of the Chukchi Sea are foreseeable. As such, greater numbers of humpback whales may use Chukchi Sea habitat, and the

effects of a VLOS entering the Chukchi Sea could increase on the humpback whale population. Previous paragraphs noted that literature on crude oil effects on mammals suggests humpback whales could be vulnerable to such a VLOS.

Minke Whale

Contact with Oil

These whales occur regularly in low numbers in the Chukchi Sea during the open-water season, but not in the Beaufort Sea east of Utqiagvik, Alaska (Ireland et al., 2008; Funk et al., 2010; Brueggeman, 2010; Roseneau, 2010). These whales are observed commonly as individuals or small groups. However, if a VLOS originating from the Proposed Action Area enters the Chukchi Sea, Minke whales may, upon contacting spilled oil, experience inhalation, ingestion, baleen fouling, skin and conjunctive tissue irritation similar to other whales, but also may exhibit detection and avoidance of spilled oil. Temporary and/or permanent, non-lethal injury could occur. When considering the numbers projected for the North Pacific and the potential numbers in the Alaska Arctic, population level effects are not anticipated; however, abundance, distribution patterns and frequency of occurrence in the Alaska Chukchi Sea could be reduced in response to possible reduction in abundance and distribution of prey resources. Recovery of minke whale to pre-spill abundance and distribution may be most dependent upon prey recovery timeframes.

Ingestion

Minke whales prey on schools of forage fish (capelin, sand lance, and herring) species as well as copepods and euphausiids in the water column and on or near the surface which may have spilled oil present. Consumption of contaminated prey, the reduction or mortality of local forage fish populations could create periods whereby summer prey would not be available for an undetermined time period depending on prey recovery rates and pioneering use of the restored prey (2011 SEIS (Section IV.E.5)). Compared to the Alaska stock/population of minke whales, a small number venture north of the Bering Strait and into the Chukchi Sea and the Proposed Action Area. Minke whales contacting oil could experience temporary and non-lethal effects within the Proposed Action Area.

Contamination and Reduction of Food Sources

These whales prey on schools of forage fish species (see the 2011 SEIS, IV.E.5, Fish Resources), as well as copepods and euphausiids in the water column and on or near the surface which may have spilled oil present. Oil-contacted whales would likely experience minor temporary and non-lethal effects similar to those described for humpback whales. When considering the numbers projected for the North Pacific, population level effects are not anticipated.

Displacement From and Avoidance of Habitat

Minke whales may be able to detect and choose to avoid a VLOS, causing displacement to other habitat areas that may or may not be as optimal as those affected by a VLOS. Impacts to the distribution and abundance of prey, if they should occur, would largely determine the seasonal distribution and habitat use by minke whales. When considering the numbers projected for the North Pacific, population level effects are not anticipated; however, distribution and abundance in the Chukchi Sea could be modified or reduced in relation to the potential modification to food source distribution and abundance as result of a VLOS originating from the Proposed Action Area.

Killer Whale

Killer whales are observed infrequently by Native hunters and others in very low numbers throughout the Alaska Chukchi and western Beaufort Seas (Frost, Lowry, and Burns, 1983; Lowry, Nelson, and Frost, 1987; Roseneau, 2010). Russian observations along the southwestern Chukchi Sea along the Chukotka Peninsula coast indicate greater abundance of killer whales in that area. They have been

primarily observed in coastal areas rather than farther offshore (Brueggeman et al., 1992, George and Suydam, 1998; Roseneau, 2010), but this could be due to higher levels of human activity and observation opportunities nearshore. Conversely, acoustic recorders detected killer whale calls in 2007 and 2009 offshore between Cape Lisburne and Point Barrow from July until October (Delarue, Yurk, and Martin, 2010; Hannay et al., 2009; Martin et al., 2008). The combination of acoustic and visual data suggests killer whales occur both offshore and near shore with no clear inshore/offshore trend.

Contact with Oil

In the event that a VLOS originating from the Proposed Action Area entered the Chukchi Sea, Killer whales may, upon contacting spilled oil, experience inhalation, ingestion, skin and conjunctive tissue irritation similar to whales analyzed earlier, and also may exhibit detection and avoidance of spilled oil. Matkin et al. (1994) reported killer whales had the potential to contact or consume oil, because they did not avoid oil or avoid surfacing in slicks. In the two years following EVOS, significant numbers (13) of individual whales, primarily reproductive females and juveniles, disappeared from the AB pod.

Dahlheim and Matkin (1994) observed AB pod members swimming through heavy slicks of oil and 18 killer whales including three calves surface in a patch of oil. They concluded that there is a spatial and temporal correlation between loss of the whales and the EVOS, but there is no clear cause-and-effect relationship. Matkin et al. (2008) note the synchronous 33% and 41% initial losses from the AB Pod and the AT1 Group in the year following the EVOS, and that 16 years post spill the AB has not recovered to former numbers and the AT1 Group has continued to decline and is now listed as depleted under the MMPA. The synchronous losses of unprecedented numbers of killer whales from these two genetically and ecologically separate groups and the absence of other obvious perturbations strengthens the link between mortalities and the lack of recovery and the EVOS. The link, however, remains circumstantial and there is not agreement among the scientific community as to whether or not there likely was an oil-spill impact on killer whales after the EVOS.

Contamination and Reduction of Food Sources

The killer whales in the Alaska Arctic are likely marine mammal predators as suggested by the few accounts of predation documented (George and Suydam, 1998). The fate of other marine mammals, and of potential prey fisheries, in detection and avoidance of a VLOS, declining or contaminated food sources causing redistribution, injury, contamination and fluctuations in prey numbers, and recovery of prey post spill would determine the persistence and use of the Proposed Action Area and adjacent areas. As an apex predator, killer whales could bioaccumulate petroleum residues in tissues. While they indicate some ability to metabolize hydrocarbon fractions ingested or otherwise absorbed, they also indicate sensitivity to CYP1A1 induction by hydrocarbon receptors; however, abundance, distribution patterns and frequency of occurrence in the Alaska Chukchi Sea could be reduced in response to possible reduction in abundance and distribution of prey resources (Wilson et al., 2005). Recovery of killer whale to pre-spill abundance and distribution would be dependent upon prey (marine mammals and fisheries) recovery timeframes.

Displacement from and Avoidance of Habitat

While no clear patterns of habitat use have developed from killer whale observations in the U.S. Arctic, toothed whales do not seem to consistently avoid oil they detect (Geraci, 1990). This would suggest that killer whales may not avoid or be displaced from habitat affected by a VLOS entering the Chukchi Sea. Contaminated food sources may cause killer whales to redistribute within their range in search of food. Matkin et al. (1994) reported killer whales had the potential to contact or consume oil, because they did not avoid oil or avoid surfacing in slicks. Dahlheim and Matkin (1994) observed AB

pod members in Prince William Sound swimming through heavy slicks of oil and surfacing in oil after EVOS.

Harbor Porpoise

Harbor porpoises have been recorded in the Chukchi Sea as far as the Barrow Canyon (Suydam and George, 1992; Roseneau, 2010) and by surveys in the northeastern Chukchi Sea by Funk et al. (2010). It appears that small numbers of harbor porpoise transit through and feed in the Chukchi Sea during summer.

Contact with Oil

Harbor porpoise are present in the Alaska Chukchi Sea during the open-water period (Suydam and George, 1992). In the event that a VLOS originating from the Proposed Action Area entered the Chukchi Sea, harbor porpoises may, upon contacting spilled oil, experience inhalation, ingestion, skin and conjunctive tissue irritation similar to bowhead whales, and also may exhibit detection and avoidance of spilled oil.

Contamination and Reduction of Food Sources

The fisheries prey base of harbor porpoise could experience reduction in abundance, distribution and diversity from contact with oil and experience injury from consuming contaminated food items or from direct contact with oil fractions of a VLOS entering the Chukchi Sea. The fate of nearshore forage fish would determine their persistence, affecting the porpoises' use of the Chukchi Sea.

Displacement from and Avoidance of Habitat

Harbor porpoise could be excluded from the Chukchi Sea if the forage fish prey base was substantially reduced or eliminated for even a short period of time as a result of a VLOS entering the Chukchi Sea.

Oil-spill Response, Cleanup, Restoration, and Remediation

Oil-spill response, cleanup, restoration, and remediation (Phase 4) has the potential to affect the three ESA-listed endangered whales (bowhead, fin and humpback), and five additional species of cetaceans (gray, minke, beluga, killer whales and harbor porpoise), and their habitats if a VLOS originating from the Proposed Action Area in the Beaufort Sea entered the Chukchi Sea.

Potential impact producing factors of a VLOS include:

- Noise and disturbance from presence of vessels transiting to the Beaufort Sea, and activity including boom and skimming operations
- Aircraft overflights, including potential application of dispersants from low flying aircraft
- In-situ burning, including noise and disturbance from support operations
- Animal rescue, scientific recovery and disposal of contaminated carcasses
- Skimmer and boom team composition, number, distribution and noise
- Beaufort Sea relief well drilling and discharges, including support activities such as icebreakers, and vessel discharges
- Bioremediation activities, including short and long-term monitoring and research studies to evaluate effectiveness of cleanup actions, that treat affected areas to neutralize toxic effects or removal and disposal operations to eliminate risk from oil contaminated soil, water, and equipment (booms, cleaning wastes, and sewage from operations, personnel)

Please refer to the 2007 FEIS (Section IV.C.1.f(1)(pages IV-80-116)) for detailed discussion of the potential effects of noise and disturbance from most of these oil and gas related activities on

endangered whales, and refer to 2007 FEIS (Section IV.C.1.h. (pages IV-149 through IV-156)) for potential effects on unlisted species of cetaceans.

In most cases, noise and disturbance (including collisions) from vessels, aircraft, drilling, and discharges are as described for the effects of these same types of operations associated with exploration, development, and production, including drilling and support activities. In most cases temporary, non-lethal effects would result from contact with a VLOS. In some cases, a cetacean species may require two or more generations coincident with restored and unaffected habitat to restore distribution and populations.

The analysis below is organized by species, with IPFs analyzed for each. Thorough discussion of potential impacts to the endangered bowhead whale will often serve to introduce concepts applicable to other species.

Beluga Whale

Potential impacts to beluga whales during Phase 4 are similar to those described for bowhead whales, except as noted below. Belugas are high frequency sensitive odontocete whales and are sensitive to high frequency noise produced by industrial activities including icebreakers (Cosens and Dueck, 1993). Avoidance and flight responses have been observed.

Icebreaker cavitation noise modeled by Erbe and Farmer (2000a) indicated icebreaker noise was audible over ranges of 35-78 km and zone of behavioral disturbance was only slightly smaller. Masking of beluga communication signals is predicted at 14-71 km off the Canadian Coast Guard icebreaker *Henry Larson*.

Beluga whale rescue actions during a VLOS are considered highly improbable by NMFS. In the event that any rescue attempts are possible, they would occur in the lagoons, where contact with oil could occur in nearshore waters close to facilities, equipment, and personnel. Rescue efforts for injured or stranded belugas may bring small vessels into the vicinity of other belugas already stressed from oil contact and watercraft. Further injury or mortality could occur during rescue operations as well as during post rescue treatment and recovery. Recovery of stranded, floating, and otherwise dead or severely injured belugas or other marine species likely would be onshore (stranded) or shallow water and not likely to be in the company of other live belugas at sea. Stranded belugas may be in groups of live animal or with injured and mortalities included. Rehabilitation and treatment facilities likely would be on board a ship or land based and some mortality and injury could occur during transport from rescue site to such facilities. Population level defects are not expected from rescue operations that are likely handling animals already injured and may be predisposed to mortality.

Bowhead Whale (Endangered)

Noise and disturbance from vessel presence and activity.

Cleanup operations following a large or very large spill would be expected to involve multiple marine vessels operating in the spill area for extended periods of time, perhaps over multiple years. Based on information provided in the above section on vessel traffic, bowheads react to the approach of vessels at greater distances than they react to most other industrial activities, and vessel and associated cleanup activities may be encountered by bowheads frequently and would likely induce avoidance responses that would cause extra expenditures of energy. According to Richardson and Malme (1993), most bowheads begin to swim rapidly away when vessels approach rapidly and directly. Avoidance usually begins when a rapidly approaching vessel is 1-4 km (0.62-2.5 mi) away. A few whales may react at distances from 5-7 km (3-4 mi). Vessels deployed on skimmer/boom teams likely would be less than 75 feet in length (about the size of a fishing vessel) and booming operations would be operating at low speeds. These vessels and smaller vessels produce higher frequency noise that

certainly add to the ambient noise levels but may not be in the frequency range for bowhead and other low frequency whales in some cases.

Cavitation noise, and onboard engine and equipment noise is not likely to propagate noise levels harmful to or causing avoidance response from bowhead whales more than 1 km (0.62 mi) from the vessel. Therefore, bowheads would likely avoid the vessels at a distance of over 1 km (0.62 mi); however, during transit operations at high speeds at night or during low visibility conditions collision or propeller strikes could occur. Larger vessels for a relief well drilling operations create noise levels from propeller cavitation, and onboard engine noise that propagates at levels causing reaction from bowhead whales. Avoidance may be related to the fact that bowheads have been commercially hunted within the lifetimes of some individuals in the population and they continue to be hunted for subsistence use throughout many parts of their range. Avoidance usually begins when a rapidly approaching vessel is 1-4 km (0.62-2.5 mi) away. A few whales may react at distances from 5-7 km (3-4 mi), and a few whales may not react until the vessel is less than 1 km (<0.62 mi) away. Received noise levels as low as 84 dB re 1 μ Pa or 6 dB above ambient may elicit strong avoidance of an approaching vessel at a distance of 4 km (2.5 mi) (Richardson and Malme, 1993).

In the Canadian Beaufort Sea, bowheads observed in vessel-disturbance experiments began to orient away from an oncoming vessel at a range of 2-4 km (1.2-2.5 mi) and to move away at increased speeds when approached closer than 2 km (1.2 mi) (Richardson and Malme, 1993). Vessel disturbance during these experimental conditions temporarily disrupted activities and sometimes disrupted social groups, when groups of whales scattered as a vessel approached. Reactions to slow-moving vessels, especially if they do not approach directly, are much less dramatic. Bowheads often are more tolerant of vessels moving slowly or in directions other than toward the whales. Fleeing from a vessel generally stopped within minutes after the vessel passed, but scattering may persist for a longer period. After some disturbance incidents, at least some bowheads returned to their original locations (Richardson and Malme, 1993). Some whales may exhibit subtle changes in their surfacing and blow cycles, while others appear to be unaffected. Bowheads actively engaged in social interactions or mating may be less responsive to vessels.

If drill vessels engaged in drilling relief wells are attended by icebreakers, as typically is the case during the fall in the Chukchi Sea, the drilling vessel noise frequently may be masked by icebreaker noise, which often is louder. Response distances would vary, depending on icebreaker activities and sound-propagation conditions. Based on models, bowhead whales likely would respond to the sound of the attending icebreakers at distances of 2-25 km (1.24-15.53 mi) from the icebreakers (Miles, Malme, and Richardson, 1987). This study predicts that roughly half of the bowhead whales show avoidance response to an icebreaker underway in open water at a range of 2-12 km (1.25-7.46 mi) when the sound-to-noise ratio is 30 dB. The study also predicts that roughly half of the bowhead whales would show avoidance response to an icebreaker pushing ice at a range of 4.6-20 km (2.86-12.4 mi) when the sound-to-noise ratio is 30 dB.

Based on all of the above information, there could potentially be displacement of bowhead whales from a feeding area following a VLOS, and this displacement could last as long as there are spill response and cleanup vessels present and possibly longer. The severity of impacts depends on the value of the feeding area affected. In the event that a high value area is affected and alternate feeding areas of similar value are scarce, effects to nutritional fitness, reproductive capacity, fetal growth rates, and neonatal survivorship could occur.

Noise and disturbance from aircraft.

After a VLOS, it is likely that overflights using helicopters and fixed-winged aircraft would track the spill and determine distributions of wildlife that may be at risk from the spill. Most bowheads are unlikely to react noticeably to occasional single passes by helicopters flying at altitudes above 150 m (500 ft). At altitudes below 150 m (500 ft), some bowheads probably would dive quickly in response

to the aircraft noise (Richardson and Malme, 1993; Patenaude et al., 1997) and may have shortened surface time (Patenaude et al., 1997). Bowhead reactions to a single helicopter flying overhead probably are temporary (Richardson, 1995a). Whales are likely to resume their normal activities within minutes.

Fixed-wing aircraft flying at low altitudes often cause hasty dives. Reactions to circling aircraft are sometimes conspicuous if the aircraft is below 300 m (1,000 ft), uncommon at 460 m (1,500 ft), and generally undetectable at 600 m (2,000 ft). Repeated low-altitude overflights at 150 m (500 ft) sometimes caused abrupt turns and hasty dives (Richardson and Malme, 1993). The effects from an encounter with aircraft are brief, and the whales should resume their normal activities within minutes. Under the intensive and frequent overflight patterns of large aircraft dispensing chemical dispersants at low level flight altitudes (less than 300 meters), bowheads would likely respond more severely and, depending on the situation, could harass bowheads and haze them in the direction of flight lines for considerable distances.

Based on all of the above information, the conclusion is that there could potentially be harassment of bowheads away from movement corridors and displacement of bowhead whales from feeding areas following a VLOS, and this displacement could last as long as there is a large amount of oil and related cleanup aircraft (especially dispersant application operations) present. Intensive and frequent low elevation overflights associated with spill response and assessment, monitoring, wildlife monitoring, and media operations could potentially harass and displace bowheads within the spill area or between the VLOS and shore-based facilities. Hazing of whales away from a hazardous spilled oil slick is possible. This is especially true during the fall migration when large numbers of whales attempt to cross the Chukchi Sea or take advantage of feeding opportunities where there is exposure to hazardous oil (that associated with large amounts of aromatic components, concentrations of prey lying within the spill contaminated surface slick, or where consumption of oil by surface feeding whales is a hazard). Hazing of migrating whales, while stressful, may be justified to prevent whales from intercepting or migrating through extended areas of spilled oil, and to encourage them to detour around hazardous accumulations of oil and continue migration to the west.

In-situ burning.

Deployment of burning operations would primarily occur near the localized origination point of the spill and in prioritized nearshore areas. Spill origination site boom and burn operation noise would likely be masked by the noise emanating from the relief drilling effort, which bowhead whales could avoid as is described in the next subsection. There would also be monitors ensuring that marine species would not be in the vicinity of the burning.

Noise and disturbance associated with skimmer and boomer operations. Booming efforts and associated skimmers utilize vessels to conduct operations, and noise effects as described above apply to bowhead whales. Offshore skimmer operations appear to be restricted to the localized area of the spill source and the specific high value nearshore and coastal sites where infrastructure and facilities for crews and equipment are available. Effects on bowhead whales from these operations are likely to be minor because the nearshore operations, noise, and sensitive coastal sites are not important fall migratory habitat to these whales. Effects are expected to be negligible.

Noise and disturbance from drilling a relief well and support activities.

Drilling a relief well is a source of noise and disturbance to bowhead whales with essentially the same impacts as the drilling of the exploration well that failed. Relief well drilling operations are likely to employ drilling vessels (with icebreaker support vessels, if necessary) and are estimated to operate at a given well site for a period of about 34 days. The greatest potential for bowhead whales to encounter relief well operations would occur during the fall migration when the majority of the population migrates westerly across the Chukchi Sea and the Proposed Action Area. Satellite tagging

studies since 2006 indicate that migrating whales could be migrating across the Chukchi Sea from September to mid-December and could encounter drilling throughout the entire migration period.

Some bowheads in the vicinity of drilling operations would be expected to respond to noise from MODUs by adjusting their migration speed and swimming direction to avoid closely approaching these noise sources. Miles, Malme, and Richardson (1987) predicted the zone of responsiveness to continuous noise sources. They predicted that roughly half of the bowheads likely would respond at a distance of 1-4 km (0.62-2.5 mi) from a drillship drilling when the signal-to-noise ratio is 30 dB. A smaller proportion would react when the signal-to-noise ratio is about 20 dB (at a greater distance from the source), and a few may react at a signal-to-noise ratio even lower or at a greater distance from the source. Bowhead whales are likely to detour around an operating relief drilling effort and continue their westward migration. These whales may encounter noise from booming, skimming, support vessels and other activities after detouring around a relief drilling operation. Reactions are likely to be localized, temporary and non-lethal. Please refer to the previous sections on noise and disturbance from vessel presence and activity, and noise and disturbance from aircraft, as well as the 2007 FEIS (Section IV.C.1.f(1)(d)) for detailed discussions of effects from these similar support activities associated with relief well drilling efforts.

Drilling a relief well would also result in discharges that could impact bowhead whales; there could be alterations in bowhead habitat as a result of exploration-related localized pollution and habitat destruction. Bottom-founded MODUs may cover areas of epibenthic invertebrates used for food by bowhead and gray whales, but would be localized and inconsequential in comparison to the vast foraging habitat available in the Chukchi Sea. Any potential effects on whales from discharges are directly related to whether or not any potentially harmful substances are released into the marine environment; what their fate in that environment is (for example, different hypothetical fates could include rapid dilution or biomagnification through the food chain); and thus, whether they are bioavailable to the species of interest. Effects likely would be negligible, because bowheads feed primarily on pelagic zooplankton and the areas of sea bottom that are impacted would be inconsequential in relation to the available habitat.

Animal rescue, scientific recovery, rehabilitation, and disposal.

Bowhead whale rescue actions are not anticipated; however, rescue efforts for some other species may bring small vessels into the vicinity of bowheads. Negligible effects are anticipated from small vessels as bowheads would likely avoid the activity and larger vessel operations that would serve as facilities from which smaller craft may be operating (see the above section on noise and disturbance from vessel presence and activity). Recovery of stranded, floating, or otherwise dead or severely injured bowheads or other marine species would be onshore (stranded) or not likely to be in the company of other bowheads at sea.

Rehabilitation and treatment facilities likely would be on board a ship or land based and not practical for large whales. Disposal of contaminated carcasses (if any), tissues and oil contaminated materials (absorbent pads, protective gear, etc.) would likely be at an authorized disposal site onshore. Negligible effects are anticipated.

Bioremediation and restoration (short and long term).

Bowhead whales would experience a wide variety of exposure to aircraft and vessel noise and traffic and effects would be similar to those analyzed above under sections for noise and disturbance from vessel presence and activity, and noise and disturbance from aircraft, as well as within the Lease Sale Final EIS (USDOI, MMS, 2007b (Section IV.C.1.f(1)(d)(3) - Effects of Noise from Icebreakers; Section IV.C.1.f(1)(d)(4) - Effects from Other Vessel Traffic Associated with Seismic Surveys; and Section IV.C.1.f(1)(d)(5) - Effects from Aircraft Traffic) (USDOI, MMS, 2007b). Aircraft and vessel operations would support many short-term efforts during the initial spill response as well as

throughout the spill containment and treatments to minimize volume, spread, and environmental consequences. These include a wide variety of surveillance missions, placement of transmitter equipped buoys (to track spill edge in real time), media coverage, monitoring wildlife, dispersant application, treatments to shorelines and waters, as well as various activities associated with spill research, monitoring, and evaluation. The fate of and effects of dispersant application upon productivity, survivorship and contamination of benthic sediments and invertebrates are addressed in the 2007 FEIS (Section IV.E.4). Overall it is possible that the use of dispersants, if permitted, could lead to effects through either reduction of food availability, bio-accumulation, or contamination. The same would be true for any cetacean.

Gray Whale

Potential impacts to gray whales during spill response and cleanup are similar to those described for bowhead whales, except as noted below.

Gray whales feed upon benthic invertebrates that occur on and in the bottom sediments. Drilling muds and cuttings from the relief well may cover portions of the seafloor and cause localized pollution. However, the effects likely would be negligible, because areas of sea bottom that are impacted would be inconsequential in relation to the available habitat.

Chemical dispersants are used to break up surface oil and disperse it into the water column, some of which may sink and affect benthic organisms preyed upon by gray whales. If their use is permitted, dispersants could potentially affect productivity, survivorship, and contamination of benthic sediments and invertebrates (the primary gray whale prey), as well as pelagic zooplankton near shore and in the Arctic marine and ice environments over the shallow continental shelf in the Chukchi Sea. Impacts to food availability and potential bioaccumulation could occur.

Additional Cetacean Species Found in the Chukchi Sea

The following species would be affected by a VLOS originating in the Proposed Action Area if oil from the VLOS entered the Chukchi Sea.

Fin Whale (Endangered)

Potential impacts to fin whales during spill response and cleanup are similar to those described for bowhead whales, except as noted below. Fin whales are low frequency sensitive whales and though thresholds for response to noise may be species specific, the general discussion relative to bowhead whales applies to fin whales. The summary of information about the current and historic distribution of fin whales indicates that a few individuals or small groups of these species could be exposed to potential noise impacts. Such effects should be temporary and minor.

Humpback Whale (Endangered)

Potential impacts to humpback whales during spill response and cleanup are similar to those described for bowhead whales, except as noted below. Humpback whales are low frequency sensitive whales and although thresholds for response to noise may be species specific, the general discussion relative to bowhead whales applies to humpback whales. The summary of information about the current and historic distribution of humpback whales indicates that a few individuals or small groups of these species could be exposed to potential noise impacts. Such effects should be temporary and minor.

Minke Whale

Potential impacts to minke whales during spill response and cleanup are similar to those described for bowhead whales.

Killer Whale

Potential impacts to killer whales during spill response and cleanup are similar to those described for bowhead whales.

Harbor Porpoise

Potential impacts to harbor porpoise during spill response and cleanup are similar to those described for bowhead whales.

4.7.6.1.3. Long Term Recovery

Over the long term, marine mammals including cetaceans would experience continued exposure to aircraft and vessel noise and traffic. Effects would be similar to those analyzed in the sections above. Aircraft and vessel operations would be supporting many longer term efforts for monitoring the recovery of resources, fate of oil and/or dispersants in the Arctic environment, and research and monitoring on the effectiveness of various cleanup and restoration practices. It would be speculative at this time to provide an estimate of the numbers, spatial and temporal framework, diversity of or effects of various post-spill research, monitoring, follow-up treatments, or intensity of post-spill activities. BOEM acknowledges the need and reality of long term post-spill activities as such events offer the unique opportunity to prevent, mitigate, and restore damaged resources and human values in the future. Research monitoring and studies are subject to scientific research permits issued by NMFS, while industrial monitoring and resource studies are subject to MMPA authorizations issued by NMFS. These MMPA permits and authorizations provide stipulations and best practices to protect cetaceans from effects, as well as enforcement measures. Vessel maneuvers, aircraft elevation limitations, limits to seasonal period of activity, tagging and handling limits, requiring marine mammal observers are some of these. Minimum impacts to individuals and large numbers of animals are the objective of these required actions. Effect to any given species of cetaceans area expected to be minimal, as subsequent determinations of studies and other efforts are to be carried out through MMPA authorizations from NMFS.

Beluga Whale

Beluga whales have been the subject of numerous studies in the in the Bering, Chukchi and Beaufort Seas. They have been indirectly affected by other ongoing efforts including BWASP, COMIDA, BOWFEST, and industry research and monitoring activities. Aircraft (fixed wing) and vessel traffic are currently and would remain the main impact producing factors upon beluga whales. It is reasonable to expect direct monitoring efforts to be directed at post-spill beluga whales as result of a VLOS event

Bowhead Whale (Endangered)

Bowhead whales have been the subject of numerous research and monitoring efforts by agencies and industry for over three decades. New efforts are likely to continue into the future with or without a VLOS event, which may serve to increase the level of research and monitoring of this species.

Gray Whale

Gray whales have been the subject of numerous studies in the 1980s and 1990s in the Bering, Chukchi, and Beaufort Seas. Since that time they have been subject to BWASP, COMIDA, BOWFEST, and industry research and monitoring activities. Aircraft (fixed wing) and vessel traffic are currently, and would remain, the main impact producing factors upon gray whales. It is reasonable to assume some direct monitoring effort to be directed at post-spill gray whale response to a VLOS event.

Additional Cetacean Species Found in the Chukchi Sea

In the event that a VLOS enters the Chukchi Sea from the Proposed Action Area and affected any of the following Chukchi Sea-centric species, long-term recovery may have some effects on fin, humpback, Minke and killer whales, as well as harbor porpoises. It is reasonable to assume some direct monitoring effort to be directed at post-spill cetacean response to a VLOS event.

Whales may experience some effects from increases in research and monitoring efforts directed at them as well as by other potential increases in post-spill research and monitoring actions. Aircraft (fixed wing) and vessel traffic are currently and would remain the main impact producing factors upon cetaceans.

4.7.6.1.4. Oil-spill Trajectory Analyses

Table 4.7.6-1. Summer Contact Probabilities for Marine Mammal ERAs.

ID	ERA	1 day LI	1 day PL	3 day LI	3 day PL	10 day LI	10 day PL	30 day LI	30 day PL	90 day LI	90 day PL	360 day LI	360 day PL
20	East Chukchi Offshore	<0.5	<0.5	<0.5	<0.5	<0.5	<0.5	<0.5	<0.5	1	<0.5	1	<0.5
22	AK BFT Bowhead FM 2	<0.5	<0.5	<0.5	<0.5	<0.5	<0.5	1	<0.5	1	1	1	1
24	AK BFT Bowhead FM 3	<0.5	<0.5	<0.5	<0.5	1	<0.5	2	2	2	2	2	2
25	AK BFT Bowhead FM 4 ³	<0.5	<0.5	1	<0.5	4	2	5	3	5	3	5	3
26	AK BFT Bowhead FM 5 ³	<0.5	<0.5	<0.5	<0.5	3	1	5	3	6	3	6	3
27	AK BFT Bowhead FM 6	<0.5	<0.5	<0.5	<0.5	1	<0.5	3	2	4	2	4	2
28	AK BFT Bowhead FM 7	<0.5	<0.5	<0.5	<0.5	<0.5	<0.5	2	1	3	1	3	1
29	AK BFT Bowhead FM 8	<0.5	<0.5	<0.5	<0.5	<0.5	<0.5	<0.5	<0.5	1	1	1	1
61	Point Lay-Point Barrow BH GW SFF	<0.5	<0.5	<0.5	<0.5	<0.5	<0.5	<0.5	<0.5	2	1	2	1
65	Smith Bay ¹	<0.5	<0.5	<0.5	<0.5	<0.5	<0.5	1	1	1	1	1	1
68	Harrison Bay ^{2,3}	<0.5	<0.5	<0.5	<0.5	1	<0.5	5	3	6	3	6	3
69	Harrison Bay/Colville Delta ^{2,4}	<0.5	<0.5	<0.5	<0.5	1	<0.5	4	2	5	3	5	3
108	Point Barrow Feeding Aggregation	<0.5	<0.5	<0.5	<0.5	<0.5	<0.5	1	<0.5	4	2	4	2
110	AK BFT Outer Shelf & Slope 1	<0.5	<0.5	<0.5	<0.5	<0.5	<0.5	<0.5	<0.5	1	<0.5	1	<0.5
111	AK BFT Outer Shelf & Slope 2	<0.5	<0.5	<0.5	<0.5	<0.5	<0.5	1	1	1	1	1	1
112	AK BFT Outer Shelf & Slope 3	<0.5	<0.5	<0.5	<0.5	<0.5	<0.5	2	1	2	2	2	2
113	AK BFT Outer Shelf & Slope 4	<0.5	<0.5	<0.5	<0.5	<0.5	<0.5	4	2	4	3	4	3
114	AK BFT Outer Shelf & Slope 5	<0.5	<0.5	<0.5	<0.5	1	<0.5	4	2	4	3	4	3
115	AK BFT Outer Shelf & Slope 6	<0.5	<0.5	<0.5	<0.5	<0.5	<0.5	2	1	3	2	3	2
116	AK BFT Outer Shelf & Slope 7	<0.5	<0.5	<0.5	<0.5	<0.5	<0.5	1	1	2	1	2	1
117	AK BFT Outer Shelf & Slope 8	<0.5	<0.5	<0.5	<0.5	<0.5	<0.5	1	1	2	2	2	2
118	AK BFT Outer Shelf & Slope 9	<0.5	<0.5	<0.5	<0.5	<0.5	<0.5	1	<0.5	2	1	2	1
119	AK BFT Outer Shelf & Slope 10	<0.5	<0.5	<0.5	<0.5	<0.5	<0.5	1	<0.5	2	1	2	1

Notes: ¹ERA 65 is important to seals and cetaceans.

²ERAs 68 and 69 are important to seals

³ERAs 25, 26, and 68 have ≥5% probability of oil contact from an LDPI Spill at 30, 90, and 360 days

⁴ERA 69 has a ≥5% probability of oil contact from the LDPI at 90 days

All other ERAs listed in this table are important to cetaceans.

Table 4.7.6-2. Winter Contact Probabilities for Marine Mammal ERAs.

ID	ERA	1 day LI	1 day PL	3 day LI	3 day PL	10 day LI	10 day PL	30 day LI	30 day PL	90 day LI	90 day PL	360 day LI	360 day PL
25	AK BFT Bowhead FM 4	<0.5	<0.5	<0.5	<0.5	1	1	1	1	1	1	1	1
26	AK BFT Bowhead FM 5	<0.5	<0.5	<0.5	<0.5	1	<0.5	1	1	1	1	1	1
27	AK BFT Bowhead FM 6	<0.5	<0.5	<0.5	<0.5	<0.5	<0.5	1	<0.5	1	<0.5	1	<0.5
28	AK BFT Bowhead FM 7	<0.5	<0.5	<0.5	<0.5	<0.5	<0.5	1	<0.5	1	<0.5	1	<0.5
30	Beaufort Spring Lead 1	<0.5	<0.5	<0.5	<0.5	<0.5	<0.5	<0.5	<0.5	1	<0.5	1	<0.5
31	Beaufort Spring Lead 2	<0.5	<0.5	<0.5	<0.5	<0.5	<0.5	1	<0.5	1	1	1	1
32	Beaufort Spring Lead 3	<0.5	<0.5	<0.5	<0.5	<0.5	<0.5	1	<0.5	1	<0.5	1	<0.5

ID	ERA	1 day LI	1 day PL	3 day LI	3 day PL	10 day LI	10 day PL	30 day LI	30 day PL	90 day LI	90 day PL	360 day LI	360 day PL
34	Beaufort Spring Lead 5	<0.5	<0.5	<0.5	<0.5	<0.5	<0.5	<0.5	<0.5	1	<0.5	1	<0.5
35	Beaufort Spring Lead 6	<0.5	<0.5	<0.5	<0.5	<0.5	<0.5	<0.5	<0.5	1	<0.5	1	<0.5
48	Chukchi Lead System 4 ²	<0.5	<0.5	<0.5	<0.5	<0.5	<0.5	1	<0.5	1	<0.5	1	<0.5
65	Smith Bay ¹	<0.5	<0.5	<0.5	<0.5	<0.5	<0.5	<0.5	<0.5	1	<0.5	1	<0.5
68	Harrison Bay ²	<0.5	<0.5	<0.5	<0.5	<0.5	<0.5	1	<0.5	2	1	2	1
69	Harrison Bay/Colville Delta ²	<0.5	<0.5	<0.5	<0.5	<0.5	<0.5	1	<0.5	1	1	1	1
112	AK BFT Outer Shelf & Slope 3	<0.5	<0.5	<0.5	<0.5	<0.5	<0.5	<0.5	<0.5	1	1	1	1
113	AK BFT Outer Shelf & Slope 4	<0.5	<0.5	<0.5	<0.5	<0.5	<0.5	<0.5	<0.5	1	1	1	1
114	AK BFT Outer Shelf & Slope 5	<0.5	<0.5	<0.5	<0.5	<0.5	<0.5	1	<0.5	1	1	1	1
115	AK BFT Outer Shelf & Slope 6	<0.5	<0.5	<0.5	<0.5	<0.5	<0.5	<0.5	<0.5	1	1	1	1
116	AK BFT Outer Shelf & Slope 7	<0.5	<0.5	<0.5	<0.5	<0.5	<0.5	<0.5	<0.5	1	1	1	1

Notes: ¹ERA 65 is important to seals and cetaceans.
²ERAs 48, 68 and 69 are important to seals
 All other ERAs listed in this table are important to cetaceans.

Table 4.7.6-3. Annual Contact Probabilities for Marine Mammal ERAs.

ID	ERA	1 day LI	1 day PL	3 day LI	3 day PL	10 day LI	10 day PL	30 day LI	30 day PL	90 day LI	90 day PL	360 day LI	360 day PL
24	AK BFT Bowhead FM 3	<0.5	<0.5	<0.5	<0.5	<0.5	<0.5	1	1	1	1	1	1
25	AK BFT Bowhead FM 4	<0.5	<0.5	<0.5	<0.5	2	1	2	1	2	1	2	1
26	AK BFT Bowhead FM 5	<0.5	<0.5	<0.5	<0.5	1	1	2	1	2	1	2	1
27	AK BFT Bowhead FM 6	<0.5	<0.5	<0.5	<0.5	<0.5	<0.5	1	1	1	1	1	1
28	AK BFT Bowhead FM 7	<0.5	<0.5	<0.5	<0.5	<0.5	<0.5	1	<0.5	1	1	1	1
30	Beaufort Spring Lead 1	<0.5	<0.5	<0.5	<0.5	<0.5	<0.5	<0.5	<0.5	1	<0.5	1	<0.5
31	Beaufort Spring Lead 2	<0.5	<0.5	<0.5	<0.5	<0.5	<0.5	<0.5	<0.5	1	<0.5	1	<0.5
32	Beaufort Spring Lead 3	<0.5	<0.5	<0.5	<0.5	<0.5	<0.5	<0.5	<0.5	1	<0.5	1	<0.5
61	Point Lay-Point Barrow BH GW SFF	<0.5	<0.5	<0.5	<0.5	<0.5	<0.5	<0.5	<0.5	1	<0.5	1	<0.5
65	Smith Bay ¹	<0.5	<0.5	<0.5	<0.5	<0.5	<0.5	<0.5	<0.5	1	<0.5	1	<0.5
68	Harrison Bay ²	<0.5	<0.5	<0.5	<0.5	1	<0.5	2	1	3	1	3	1
111	AK BFT Outer Shelf & Slope 2	<0.5	<0.5	<0.5	<0.5	<0.5	<0.5	<0.5	<0.5	1	<0.5	1	<0.5
112	AK BFT Outer Shelf & Slope 3	<0.5	<0.5	<0.5	<0.5	<0.5	<0.5	1	1	1	1	1	1
113	AK BFT Outer Shelf & Slope 4	<0.5	<0.5	<0.5	<0.5	<0.5	<0.5	1	1	2	1	2	1
114	AK BFT Outer Shelf & Slope 5	<0.5	<0.5	<0.5	<0.5	<0.5	<0.5	1	1	2	1	2	1
115	AK BFT Outer Shelf & Slope 6	<0.5	<0.5	<0.5	<0.5	<0.5	<0.5	1	1	2	1	2	1
116	AK BFT Outer Shelf & Slope 7	<0.5	<0.5	<0.5	<0.5	<0.5	<0.5	<0.5	<0.5	1	1	1	1
117	AK BFT Outer Shelf & Slope 8	<0.5	<0.5	<0.5	<0.5	<0.5	<0.5	<0.5	<0.5	1	1	1	1
118	AK BFT Outer Shelf & Slope 9	<0.5	<0.5	<0.5	<0.5	<0.5	<0.5	<0.5	<0.5	1	<0.5	1	<0.5
119	AK BFT Outer Shelf & Slope 10	<0.5	<0.5	<0.5	<0.5	<0.5	<0.5	<0.5	<0.5	1	<0.5	1	<0.5

Notes: ¹ERA 65 is important to seals and cetaceans.
²ERA 68 is important to seals
 All other ERAs listed in this table are important to cetaceans.

Table 4.7.6-4. Seasonal Contact Probabilities for Marine Mammal LSs.

ID	LS	1 day LI	1 day PL	3 days LI	3 days PL	10 days LI	10 days PL	30 days LI	30 days PL	90 days LI	90 days PL	360 days LI	360 days PL
Summer 85	Utqiagvik, Browerville, Elson Lagoon	<0.5	<0.5	<0.5	<0.5	<0.5	<0.5	<5	<5	1	<5	1	<5
Winter none	None	<0.5	<0.5	<0.5	<0.5	<0.5	<0.5	<0.5	<0.5	<0.5	<0.5	<0.5	<0.5
Annual 85	Barrow, Browerville, Elson Lagoon	<0.5	<0.5	<0.5	<0.5	<0.5	<0.5	<5	<5	1	<5	1	<5

Note: LS 85 is important to polar bears and/or Pacific walruses.

Table 4.7.6-5. Contact Probabilities for Marine Mammal GLSs.

ID	GLS	1 day LI	1 day PL	3 days LI	3 days PL	10 days LI	10 days PL	30 days LI	30 days PL	90 days LI	90 days PL	360 days LI	360 days PL
----	-----	----------	----------	-----------	-----------	------------	------------	------------	------------	------------	------------	-------------	-------------

ID	GLS	1	1	3	3	10	10	30	30	90	90	360	360
		day	day	days	days	days	days	days	days	days	days	days	days
		LI	PL	LI	PL	LI	PL	LI	PL	LI	PL	LI	PL
Summer		LI	PL	LI	PL	LI	PL	LI	PL	LI	PL	LI	PL
169	Smith Bay Spotted Seal Haulout	<0.5	<0.5	<0.5	<0.5	<0.5	<0.5	1	1	2	1	2	1
173	Harrison Bay Spotted Seal Haulout	<0.5	<0.5	<0.5	<0.5	<0.5	<0.5	1	1	1	1	1	1
176	98-129 Summer	12 ¹	27 ¹	28 ¹	40 ¹	40 ¹	46 ¹	43 ¹	48 ¹	43 ¹	48 ¹	43 ¹	48 ¹
178	104-129 Fall	12 ¹	26 ¹	25 ¹	34 ¹	30 ¹	37 ¹	30 ¹	37 ¹	30 ¹	37 ¹	30 ¹	37 ¹
179	Foggy Island Bay	24 ¹	53 ¹	48 ¹	72 ¹	57 ¹	77 ¹	58 ¹	78 ¹	58 ¹	78 ¹	58 ¹	78 ¹
Winter		LI	PL	LI	PL	LI	PL	LI	PL	LI	PL	LI	PL
176	98-129 Summer	4	9 ¹	10 ¹	13 ¹	14 ¹	16 ¹	16 ¹	17 ¹	17 ¹	18 ¹	17 ¹	18 ¹
178	104-129 Fall	4	11 ¹	9 ¹	16 ¹	13 ¹	18 ¹	14 ¹	18 ¹	14 ¹	19 ¹	14 ¹	19 ¹
179	Foggy Island Bay	21	51	46	69	55	76	57	77	57	77	57	77
180	110-124 Winter	<0.5	<0.5	<0.5	<0.5	1	1	2	2	3	2	3	2
Annual		LI	PL	LI	PL	LI	PL	LI	PL	LI	PL	LI	PL
169	Smith Bay Spotted Seal Haulout	<0.5	<0.5	<0.5	<0.5	<0.5	<0.5	<0.5	<0.5	1	<0.5	1	<0.5
176	98-129 Summer	6 ¹	14 ¹	14 ¹	20 ¹	21 ¹	24 ¹	23 ¹	25 ¹	24 ¹	25 ¹	24 ¹	25 ¹
178	104-129 Fall	6 ¹	15 ¹	13 ¹	20 ¹	17 ¹	23 ¹	18 ¹	23 ¹	18 ¹	23 ¹	18 ¹	23 ¹
179	Foggy Island Bay	22 ¹	51 ¹	46 ¹	70 ¹	56 ¹	76 ¹	57 ¹	77 ¹	57 ¹	77 ¹	57 ¹	77 ¹
180	110-124 Winter	<0.5	<0.5	<0.5	<0.5	1	1	2	1	2	2	2	2

Notes: ¹Cells with contact probabilities $\geq 5\%$.

²Light blue cells represent ERAs important to seals.

³White cells represent ERAs important to polar bears or Pacific walruses.

A hypothetical VLOS could contact offshore areas when and where marine mammals may be present. The location, timing and magnitude of a VLOS and the concurrent seasonal distribution and movement of cetaceans would determine whether or not contact with the oil occurs. The Oil-spill Risk Analysis (OSRA) models oil-spill trajectories from 6 launch areas (LAs). The LAs are shown in Appendix A, Map A-5.

This section describes the results estimated by the OSRA model for a hypothetical VLOS originating at the proposed LDPI or the associated pipeline contacting specific Environmental Resource Areas (ERAs), Land Segments (LSs), or Grouped Land Segments (GLSs). ERAs, LSs, and GLSs are spatial representations (polygons) that indicate a geographic area important to one or more marine mammal species. Fresh oil contributed to the marine environment after October 31 would be considered a “winter spill.” The effectiveness of oil-spill response activities is not factored into the results of the OSRA model.

The following discussion presents the results estimated by the OSRA model of the hypothetical VLOS contacting ERAs important to cetacean species. The dynamics of oceanographic, climatic, and biotic factors affecting the distribution and abundance of prey, timing of accessibility to habitats, and corridors for movement determine the opportunity for cetaceans and oil to come into contact. There are situations where aggregations of cetaceans of one or more species can contact oil. Trajectory contact with an ERA does not indicate the entire ERA is oiled, only that it is contacted somewhere.

Beluga Whale

No ERAs for beluga whales had a $\geq 5\%$ probability of being contacted (Table 4.7.9-3) at any time, and so beluga whale ERAs are unlikely to be individually contacted.

Bowhead Whale (Endangered)

Summer The OSRA model estimates ERAs 25 and/or 26 have a $\geq 5\%$ summer contact probability between 30 and 360 days after spill materials are released (Table 4.7.6-6. Both ERAs represent sections of the fall migration corridor used by migrating bowhead whales leaving the Beaufort Sea. All other ERA summer contact probabilities are $0 < 5\%$ and so those ERAs are unlikely to be contacted individually.

Winter All winter contact probabilities for ERAs had <5% probability of occurring and so are unlikely to occur on an individual basis.

Annual All annual contact probabilities for ERAs had <5% probability of occurring and so are unlikely to occur on an individual basis.

Table 4.7.6-6. Bowhead Whales–Summer, Winter, and Annual Fraction of VLOS.

ID	ERA	1 day LI	1 day PL	3 day LI	3 day PL	10 day LI	10 day PL	30 day LI	30 day PL	90 day LI	90 day PL	360 day LI	360 day PL
Summer 25	AK BFT Bowhead FM 4	<0.5	<0.5	1	<0.5	4	2	5	3	5	3	5	3
Summer 26	AK BFT Bowhead FM 5	<0.5	<0.5	<0.5	<0.5	3	1	5	3	6	3	6	3

Notes: Bowhead Whales - Fraction of a VLOS (expressed as a percent of trajectories) Contacting a Certain ERA within 1, 3, 10, 60, 90 or 360 Days during Summer or Winter from any LA.

ERA 25 Fraction $\geq 5\%$ at 30, 90, and 360 days from spill.

ERA 26 Fraction $\geq 5\%$ at 30, 90, and 360 days from spill.

There are no Winter or Annual Fractions of VLOS for Bowhead Whales

Source: Appendix A, Tables A.1-11, A.2-28, 30, and 54, Maps A-2a through 2f, LA= Launch Area, ERA = Environmental Resource Area.

Fin Whale (Endangered)

No ERAs for fin whales had a $\geq 5\%$ probability of being contacted at any time (Table 4.7.6-3), and so fin whale ERAs are unlikely to be individually contacted.

Gray Whale

No ERAs for gray whales had a $\geq 5\%$ probability of being contacted at any time, and so gray whale ERAs are unlikely to be individually contacted.

Harbor Porpoise

No ERAs for harbor porpoises have been established, and they are not documented east of Point Barrow in the Beaufort Sea. No marine mammal ERAs in the Chukchi Sea had a $\geq 5\%$ probability of being contacted (Table 4.7.6-3) at any time, and so ERAs for harbor porpoises are unlikely to be individually contacted.

Humpback Whale (Endangered)

No ERAs for humpback whales had a $\geq 5\%$ probability of being contacted (Table 4.7.6-3) at any time, and so humpback whale ERAs are unlikely to be individually contacted.

Killer Whale

No ERAs for killer whales have been established, however they prey on other marine mammals in the Chukchi Sea. No marine mammal ERAs in the Chukchi Sea had a $\geq 5\%$ probability of being contacted (Table 4.7.6-3) at any time, and so ERAs of killer whale prey species are unlikely to be individually contacted.

Minke Whale

No ERAs for minke whales had a $\geq 5\%$ probability of being contacted (Table 4.7.6-3) at any time, and so minke whale ERAs are unlikely to be individually contacted.

4.7.6.1.5. Conclusion

Direct contact with spilled oil resulting from a VLOS would have the greatest potential to affect bowhead whales migrating through their fall migration corridor at ERAs 25 and 26, particularly if toxic fumes from fresh oil are inhaled where bowheads aggregate.

Most cetaceans would likely avoid oil-spill response and cleanup activities, possibly resulting in displacements from preferred feeding habitats, and temporary interference with migrations. Presence of oil on and in the water may be avoided by some cetaceans, but not others, depending on the timing, volume, contents, and duration of a VLOS. Cetaceans generally could experience some loss of seasonal habitat, reduction of prey, and/or contamination of prey. Consumption of contaminated prey may also affect the distribution, abundance and health of cetaceans. A variety of effects on cetaceans could result from contact with and exposure to a VLOS ranging from no effect, to avoidance, to some mortality depending the circumstances unique to a spill event. Several cetacean species occur in the Chukchi Sea where the contact probabilities are all <5%, but only 3 regularly occur in the Beaufort, and of the cetacean species in the Beaufort Sea, only bowhead whales have ERAs that have $\geq 5\%$ contact probabilities (Table 4.7.6-1). Of the Beaufort Sea cetacean ERA's that could be contacted, only ERAs 25 and 26, representing two segments of the bowhead whale fall migration corridor, were contacted, while all other contact probabilities were <5%, and not reasonably foreseeable.

More species-specific summary and conclusions are provided below:

Beluga Whale

Beluga whales are vulnerable to contact with a VLOS when they feed across the Beaufort Sea. The fate of beluga prey, especially Arctic cod and other Arctic fisheries, could affect seasonal habitat use, determine if toxic amounts of contaminated fish are ingested, or possibly change distribution of these whales until fisheries recover. Temporary and/or permanent injury and non-lethal effects could also occur. Toxic levels of ingestion could alter endocrine system and reproductive system function and in severe cases might result in some mortalities.

Few belugas would come into contact with the human activities associated with cleanup operations in near shore areas, where localized intensive boom and skimming efforts to protect lagoons and other coastal resources would occur. Avoidance behavior and stress to some belugas in coping with concentrated cleanup activities is likely. Beluga whales could inhale toxic fumes from spilled oil. Prolonged inhalation of toxic fumes or surface oil could result in temporary and/or permanent injury or mortality to some individuals.

Displacement from, or avoidance of, nearshore habitats could occur over several years after a spill; however, no contact probabilities $\geq 5\%$ for beluga whale ERAs are documented in the Beaufort, or the Chukchi Seas. Since no ERAs for belugas had contact probabilities $\geq 5\%$, contact of those ERAs are not reasonably foreseeable.

Post spill recovery of belugas to pre-spill abundance and habitat use patterns would be dependent upon the recovery periods necessary to restore pre-spill levels of prey populations and the quality of preferred habitats. Recovery would also depend on the amount of human activity in and adjacent to the preferred habitats.

Bowhead Whale (Endangered)

Bowhead whales could experience contact with fresh oil during summer and fall feeding events aggregations and migration in the Beaufort Sea. Skin and eye contact with oil could cause irritation and various skin disorders. Toxic aromatic hydrocarbon vapors are associated with fresh oil, and prolonged inhalation of such vapors could lead to impaired endocrine system function that adversely affect reproductive function (that may be temporary or permanent), and/or bowhead mortality in situations where prolonged exposure occurs. Dissipation of toxic fumes into the atmosphere from the rapid aging of fresh oil, and disturbances from response-related noise and activity limits the potential for prolonged inhalation of toxins.

The exposure of bowhead whale aggregations, especially if calves are present, could result in mortalities, and surface-feeding bowheads may ingest surface and near-surface oil fractions with their

contaminated prey. Incidental ingestion of oil fractions in bottom sediments could also occur during near-bottom feeding. Ingestion of oil may result in temporary and permanent damage to bowhead endocrine function and reproductive system function; and if sufficient amounts of oil are ingested mortality of individuals may also occur.

Population level effects are not expected; however, there is a small possibility of a high impact VLOS event in which large numbers of whales experience prolonged exposure to toxic fumes and/or ingest large amounts of oil, injury and mortality is possible to a population level effect.

Bowhead whales could be exposed to a multitude of short and longer term additional human activity associated with initial spill response, cleanup and post event human activities that include primarily increased and localized vessel and aircraft traffic associated with reconnaissance, media, research, monitoring, booming and skimming operations, in-situ burning, dispersant application and drilling of a relief well. These activities would be expected to be intense during the spill cleanup operations and expected to continue at reduced levels for potentially decades post event. Specific cetacean protection actions would be employed as the situation requires and would be modified as needed to meet the needs of the response effort. The response contractor would be expected to work with NMFS and state officials on wildlife management activities in the event of a spill. The two aforementioned groups most likely would have a presence at the Incident Command Post to review and approve proposed activities and monitor their impact on cetaceans. As a member of the team, NMFS personnel would be largely responsible for providing critical information affecting response activities to protect cetaceans in the event of a spill.

Bowheads would be expected to avoid vessel supported activities at distances of several km depending on the noise produced by vessel sound sources; drill rig; numbers and distribution, size and class of vessels. Migrating whales would be expected to divert around relief well drilling operations and up to a few km around vessels engaged in a variety of activities. Most activity would occur inside Stefansson Sound, where bowhead whales are rarely documented. Temporary and non-lethal effects are likely from the human activities that would be related to VLOS response, cleanup, remediation, and recovery. Displacement away from or diversion away from aggregated prey sources could occur, resulting in important feeding opportunity relative to annual energy and nutrition requirements. Frequent encounters with VLOS activities and lost feeding opportunities could result in reduced body condition, reproductive performance, increased reproductive interval, decreased in vivo and neonatal calf survival, and increased age of sexual maturation in some bowheads. Effects from displacement and avoidance of prey aggregations and feeding opportunities as a result of human activities associated with spill response, cleanup, remediation and recovery are not expected to result in population level effects.

Fin Whale (Endangered)

The absence of fin whales in the Beaufort Sea, low numbers in the Chukchi Sea, and the low contact probabilities with areas fin whales might occur indicates a VLOS has a remote likelihood of affecting fin whales. Consequently, the overall effects of a VLOS on fin whales should be negligible.

Gray Whale

Gray whales do not aggregate in the Beaufort Sea, and have only been documented as the occasional individual or small group scattered along the Beaufort Sea Shelf. Aggregations consistently occur near shore along the Alaska Chukchi Sea coast from west of Wainwright to northeast of Point Barrow.

Oil contamination of benthic sediments leading to mortality loss of benthic invertebrate prey species for gray whales might require many years to recover from a VLOS, and lead to the abandonment of some feeding areas. A potential secondary effect to feeding area abandonment could be a reduction in health due to low energy reserves that would compromise a gray whales ability to migrate to

wintering areas in the Sea of Cortez, perhaps even leading to mortalities. A large loss in the Western North Pacific stock of gray whales could take decades to recover, depending on the magnitude of the losses.

No gray whale ERAs had contact probabilities $\geq 5\%$, so the potential for large numbers of gray whales being exposed to materials from a VLOS is extremely unlikely and not reasonably foreseeable. Of the marine mammal ERAs that were contacted, the only ones with $\geq 5\%$ contact probabilities were ERAs 25 and 26 in the Beaufort Sea. Since those ERAs are associated with the fall bowhead whale migration corridor, and have little to do with gray whales, it is reasonable to assume that no more than a few gray whales in the Beaufort Sea would likely contact spill materials from a VLOS originating at the LI.

For these reasons a VLOS should have no population-level effects on gray whales, and would most likely have negligible to minor effects on a small number of individual whales dispersed between the LI and ERAs 25 and 26. Consequently, a VLOS would most likely have negligible effects on the gray whale population, and negligible to major effects on a few individuals.

Harbor Porpoise

The absence of harbor porpoises in the Beaufort Sea, low numbers in the Chukchi Sea, and the low contact probabilities with areas where they might occur indicates a VLOS has a remote likelihood of affecting them. Consequently, the overall effects of a VLOS on harbor porpoises should be negligible.

Humpback Whale (Endangered)

The absence of humpback whales in the central Beaufort Sea, low numbers in the Chukchi Sea, and the low contact probabilities with areas humpback whales might occur indicates a VLOS has a remote likelihood of affecting them. Consequently, the overall effects of a VLOS on humpback whales should be negligible.

Killer Whale

The absence of killer whales in the Beaufort Sea, low numbers in the Chukchi Sea, and the low contact probabilities with areas where they might occur indicates a VLOS has a remote likelihood of affecting them. Consequently, the overall effects of a VLOS on killer whales should be negligible.

Minke Whale

The absence of minke whales in the Beaufort Sea, low numbers in the Chukchi Sea, and the low contact probabilities with areas they might occur indicates a VLOS has a remote likelihood of affecting them. Consequently, the overall effects of a VLOS on minke whales should be negligible.

4.7.6.2. Ice Seals

A VLOS would affect bearded, ringed, and spotted seals, and could affect a few ribbon seals in the vicinity of Point Barrow. Ice seals have some capacity to rid their bodies of accumulated hydrocarbons via renal and biliary mechanisms, mostly within 7 days (Engelhardt, 1983), and in most instances where seals have been contacted by oil they fully recover. Onshore contact is only expected to affect spotted seals in localized areas in the Beaufort Sea and those in the Chukchi Sea should remain unaffected by a VLOS from the LI. Ringed and bearded seals are most vulnerable during the winter when they concentrate more along lead systems and shear zones that provide them access to the ocean. Ribbon seals have not been documented in the Beaufort Sea east of Point Barrow, Alaska, and are highly unlikely to be affected by a VLOS. In all cases, each species should recover from the effects of a VLOS within three generations or less. Furthermore, both spotted and ribbon seals, along with the majority of bearded and ringed seals seasonally migrate out of the Beaufort Sea and into the Chukchi and Bering Seas, placing them beyond the immediate area of effects from a winter VLOS.

4.7.6.2.1. Initial Event

The hypothetical VLOS scenario would begin with a well-control incident resulting in a blowout and its immediate consequences, but not the release of materials into the water, amounting to negligible, temporary, non-lethal effects on pinnipeds.

Explosion

Materials released during a blowout could ignite, causing an explosion. An explosion from the LI would create a single pulse sound event that could potentially injure pinniped hearing, depending on the sound levels. PTS would be considered a permanent injury, decreasing an individual's ability to successfully interact with their environment and, potential leading to declining health and/or premature mortality. However, it is unlikely seals in the vicinity of the LI actually would experience TTS or PTS, due to the bermed perimeter of the island which would buffer much of the lateral sound from reaching the water's surface, while directing much of the sound from an explosion vertically.

4.7.6.2.2. Offshore Oil

Ice seals would be exposed to hydrocarbons in offshore areas during a hypothetical VLOS event. Oil in the Chukchi Sea could cause short-term physiological effects to ice seals, could affect their prey resources, and could cause mortalities of some seals. Additional information about potential impacts of crude oil on seals is available in the 2007 FEIS (Section IV.C.1.h (4)) and here in Section 4.3.7.

Contact with Spilled Oil

The vulnerability of individual ice seal species to contacting crude oil is largely a function of their seasonal use of different areas. Some coastal use areas, polynyas, and lead systems are the most likely areas for relatively larger numbers of seals to come in contact with spilled oil. These are all aggregation areas for different species of seals at different times of the year. Differences in ice seal distributions are noted in the subsections below.

Spotted seals are known to aggregate in coastal areas during summer months, mostly in Kasegaluk Lagoon, and the areas between Kotzebue and Wales, Alaska. However, they also occur in small numbers in Smith Bay, Peard Bay, Dease Inlet, and the Colville and Sagavanirktok River Deltas, Alaska; plus sections of the Chukotka coastline, particularly near Kolyuchin Bay and coastal areas to the south. During a recent shallow geohazard survey (BPXA, 2014) survey spotted seals were the most numerous marine mammal observed by PSOs working for industry in the proposed LDPI area.

During the open-water season, ringed and bearded seals mostly associate with areas of sea ice, where they occur in their highest numbers; however a few should remain in Stefansson Sound (BPXA, 2014) and other areas where they would feed and occasionally haul-out if necessary. In contrast ribbon seals are mostly found in the pelagic areas of the southern Chukchi Sea, away from the coast and areas of sea ice.

As ice encroaches south in the fall, all of the ice seal species move south in tandem with the development of winter sea ice, eventually occupying the Bering Sea. However, many ringed and some bearded seals remain in the Chukchi and Beaufort Seas, using breathing holes, or lead systems and polynyas to access water. During the months of winter and early spring ringed seals prefer areas of landfast ice, while bearded seals utilize leads and polynyas, and hauling out on ice floes and pack ice.

Ice seals have some ability to purge their bodies of hydrocarbons through renal and biliary pathways. They can develop lesions on their eyes and some internal organs after contacting crude oil, though some studies indicated many of the physiological effects self-correct if the duration of exposure is not too great (Engelhardt, Geraci, and Smith, 1977; Engelhardt, 1982, 1983, 1985; Smith and Geraci 1975; Geraci and Smith 1976a, 1976b; St. Aubin, 1990). However, Spraker et al. (1994) observed

lesions in the thalamus of harbor seal brains after they were oiled, possibly explaining motor and behavioral anomalies (Engelhardt 1983), and Lowry, Frost, and Pitcher (1994) noted reproductive complications in harbor seals exposed to oil from the *Exxon Valdez* Oil Spill.

While seals may experience short-term physiological impacts from exposure to an oil spill, Engelhardt (1983) states that exposure studies in ringed seals reveals they have the capacity to excrete accumulated hydrocarbons via renal and biliary excretion mechanisms, clearing blood and most other tissues of the residues within 7 days. In harbor seals (*Phoca vitulina*), a related species, a more recent investigation found no significant quantities of oil in the tissues (liver, blubber, kidney and skeletal muscles) of harbor seals exposed to the EVOS (Bence and Burns 1995), and the decreasing trend in harbor seal numbers since EVOS (4.6% per year) may have been erroneous since harbor seal populations were declining before the spill (Frost et al., 1999). A further analysis of harbor seal population trends and movements in Prince William Sound suggested harbor seals moved away from some oiled haulouts during the EVOS (Hoover-Miller et al., 2001) and the original estimate of more than 300 harbor seal mortalities may have been overestimated.

The discontinuous area of a VLOS depends on when and where a spill occurred, the spill flow rate, and duration. Based on average ice seal densities, the size of the surface slick could contact tens of thousands of seals. If ice seals are able to successfully detect/avoid crude oil or hydrocarbons from their bodies, as has been suggested (Geraci and St. Aubin, 1988), there should be few seal mortalities from a VLOS. It is conceivable, however, that because thousands of ice seals could be contacted, a number of those seals could die, especially if a large amounts of spilled materials were to reach a lead system. For these reasons a several hundred bearded, and ringed seal mortalities could occur after a VLOS. Considering the lower numbers of spotted seals believed to seasonally reside in the Beaufort Sea, spotted seal mortalities could number in the tens to low hundreds.

Changes in Prey Resources. A potential effect of a VLOS could be the loss of fishes and invertebrates from local populations, particularly Arctic and saffron cod, arthropods, mollusks, and other invertebrates. Adult ringed, spotted, and ribbon seals mostly rely on fishes for the majority of their diets, although young seals may consume large numbers of arthropods like euphausiids and copepods. Bearded seals mostly feed on mollusks, polychaetes and arthropods to a large degree, but sometimes fish also account for a substantial portion of their diet. Impacts to these food sources over a large area could have far-reaching effects that could last for years, reducing the quantitative and qualitative food base for high level predators such as seals. Such losses in prey would reduce productivity or even cause short-term absence of seal populations ice seals from that area.

The constituents in crude oil break down over time, and weather, ocean currents, and temperature interact to disperse and volatilize oil slicks. Many, if not most, marine organisms produce large numbers of offspring which are dispersed by ocean currents. Consequently, the loss of biota from an area exposed to crude oil should be replenished by immigration from other areas within two or so years, especially when the high reproductive rates, mobility of many marine organisms, and the influx of immigrant organisms via ocean currents is considered. Some prey groups such as mollusks may recover more rapidly than others such as fishes because of differing maturation rates, and reproduction potentials. Any ensuing prey distribution changes could contribute to the absence of several thousand individual bearded, and ringed seals, and several hundred spotted seals from an area where the food stocks have been depleted or destroyed. Such absences could take years to recover.

4.7.6.2.3. Onshore Contact

The only seal species likely to be affected by spills contacting coastlines would be spotted seals. Bearded, ringed, and ribbon seals spend their lives on or around sea ice and rarely if ever come ashore in coastal areas. Known spotted seal onshore haulouts along the Beaufort Sea coast occur at the mouths of the Colville and Sagavanirktok Rivers, Dease Inlet, and Smith Bay.

Contact with Oil

The effects of seals contacting crude oil were described in Section 4.5.7.1.2, Phase 2, and in Section 4.2.4.

Contamination

The effects of oil contamination on spotted seals are the same as described in Phase 2. However, abrasive sediments and sands may scrub oil from the coats of some seals lessening the amount and duration of contamination that individual seals experience. Other individual seals that are oiled may inadvertently pick up debris and some sediment that adhere to the oil on their skins and hair. Nonetheless, Lowry et al. (1994) found that oiled seal skins shed their crude oil coating after about 7 days of immersions. Likewise, phocid seals rely on a thick layer of blubber for insulation which eliminates the potential for spilled oil to affect their thermoregulation abilities.

Loss of Access to Habitat

A VLOS that contacts the shoreline would not necessarily affect the foraging success of bearded or ringed seals since they feed in the water and prefer sea ice haulouts; however, a lingering spill contacting the shoreline, and remaining spread over large areas of water could affect foraging success for the different seals in the Beaufort Sea. Such effects might last across seasons and perhaps a few years.

4.7.6.2.4. Spill Response and Cleanup

Spill response activities could disturb and displace seals from affected marine and coastal areas. Negative short term impacts from disturbance would be outweighed by beneficial effects from intentionally or unintentionally hazing seals away from oiled areas.

The effects of vessel and aircraft traffic associated with an oil-spill response and cleanup may displace seals. Such effects have been observed in numerous ship and air-based surveys in the Beaufort and Chukchi Seas over the years (Blees et al., 2010; Brewer et al., 1993; Brueggeman et al., 1991, 2009a, 2010; Funk et al., 2010; Treacy, 1996) and were described in Section 4.2.4. Some activities such as in-situ burning, animal rescue, the use of skimmers and booms, drilling relief wells, etc. could have additive effects, most likely displacing seals even more. Marine mammal observers would be used, but only a few seals should be temporarily frightened from the area, since many would have already left the area after detecting the spilled material from the VLOS. Moreover, if the prey base is adversely affected most seals would leave the affected area out of necessity so that they could feed. The use of dispersants are unlikely to have any immediate direct effects on seals in an area exposed to a VLOS event; however, there may be some adverse consequences to using certain types of dispersants which may affect the food web, and the long-term effects of dispersant use may extend beyond the proposal area to varying degrees.

Cleanup activities such as beach cleaning may be performed with a high degree of success using newer technologies such as ionic solutions (Hogshead, Evangelos, Williams et al., 2010; Painter, 2011). However, other activities such as spill cleanup under ice or in areas of broken ice may be more problematic. The effects of these activities on seals could vary, depending upon the presence of seals in an area, and pre-existing stress levels. Due to the pervasive permafrosted soils along the Arctic coastline, and a general lack of rocky coastal areas on the Beaufort Sea coast in Alaska, the materials spilled from a VLOS should have a limited ability to spread through the soil profile, making cleanup of shoreline areas easier than in areas where oil and other hydrocarbons can seep down into the soil matrix since the ice in permafrost should repel hydrocarbons towards the soils surface.

In addition, hazing seals from oiled areas could preclude many of the most severe potential impacts from occurring.

4.7.6.2.5. Long-term Recovery

Long-term is defined as affecting populations for more than two years. The possible loss of several thousand spotted, bearded, and ringed seals could continue for two years and potential recovery may enter the long-term phase. The recent listing of bearded seals under the ESA was based on a concern that the species could experience population declines due to the future effects of climate change. For the purposes of this analysis, the described mortality levels may recover within three generations if ice seal populations are capable of maintaining their present populations. If ice seal population trends begin a prolonged downward trend, the losses from a VLOS event may not be recoverable, leading to major effects to seal populations. Such effects would depend on the severity of climate induced population declines, available habitat, predation, habitat quality, etc., and are merely speculative.

4.7.6.2.6. Oil-spill Trajectory Analysis

A VLOS could contact offshore and nearshore areas where seals may be present. The percent of trajectories contacting depends on the location, timing, and magnitude of the spill. The OSRA model uses 2 launch areas that include the LDPI (LI) to model the origin of spill trajectories.

Drilling from the LDPI could occur year-round, so both summer and winter spills could occur. A VLOS occurring during winter from the LI would most likely spill out onto the surface of landfast sea ice, and would be less likely to enter the water before being collected and sent to a processing area. A VLOS that occurred during the summer could spread, however the proximity of the LI and the PL to the coast lowers the potential for many areas to be contacted. By being close to the coast it is safe to assume significant portions of any VLOS would contact the nearby coastline and spread no farther.

As time progresses after a release event, a VLOS becomes patchy and more widely distributed, which would then permit some seals to leave the area, or remain without the level of adverse consequences associated with an extensive, widespread layer of spilled materials.

A VLOS continuing after October 31 is treated as a winter spill. Since the hypothetical oil spill could continue after October 31 and/or melt out of ice during the following spring, potential trajectories are also assessed over an assessment period of 360 days.

In the event of a VLOS not all of the hydrocarbons are discharged at once, as often occurs with marine accidents such as the *Exxon Valdez* Oil Spill in Prince William Sound, Alaska. Instead they flow into the ocean at rates that decrease over time. For the briefest spill period, BOEM assumes that a spill could persist on the surface of the water for up to three weeks; therefore, a 60 day period of potential contact was analyzed. However, if a spill were to occur late in the open-water season, the liquid hydrocarbons may freeze into the sea ice, and could remain overwinter without any extensive amount of weathering. If this were to happen, quantities of unweathered oil could end up being transported to different areas in the Chukchi and Beaufort Seas and be released in the spring. To address concerns such as this, BOEM has also analyzed a period of 360 days.

This section describes the results estimated by the OSRA model of a hypothetical VLOS in the Beaufort Sea from LI or PL contacting specific ERAs important to ice seals. An ERA noted in this section is a polygon used to represent an area important to one or more seal species at some stage in their life cycle. During winter bearded and ringed seals are the only species expected to be present in the area and their primary winter habitats include polynyas, lead systems, and landfast or pack ice for ringed or bearded seals respectively. During the summer (open-water) season ringed, spotted, and bearded seals may be found swimming in open water, though their numbers increase with proximity to areas of sea ice. Spotted seals are seasonal visitors to the Beaufort and Chukchi Seas, and mostly occupy nearshore areas, bays, and lagoon systems where they periodically haul out, sometimes in large numbers. A few individual spotted seals typically haul out on river bars in the Sagavanirktok and Colville River Deltas. Ribbon seals are mostly pelagic, and tend to occupy the southern and western Chukchi Sea and are not known to occur in the Beaufort Sea beyond Point Barrow. With the

exception of hauled out spotted seals, other ice seals do not tend to be gregarious for social reasons as much as to exploit limited resources such as available polynyas and lead systems.

ERAs and GLSs ice seal concentrations are shown in Appendix A, Table A.1-14, and the likelihood of any species being affected by a VLOS would be determined by a number of factors including: seasonality, occurrence of a species; spill avoidance abilities of a species; presence; distribution; habitat use; diet; timing of a spill; spill constituents; spill magnitude; spill duration; and a species' ability to persist in a contaminated area. Bearded and ringed seals occur in the Chukchi and Beaufort Seas year-round, although a very large proportion of their populations winter south in the Bering Sea ice areas. In contrast, ribbon seals mostly summer in the northern Bering Sea and in the southern Chukchi Sea, where little ice persists during the open-water season. Many spotted seals winter in the Bering Sea; however, large aggregations (100s and 1,000s) may be found in Kasegaluk Lagoon, Avak Inlet, and between Kotzebue and Wales on the Seward Peninsula coast, while lower concentrations (10s) occur in Admiralty, Smith, Kugrua and Peard Bays; and the Colville River Delta during summer.

The following paragraphs present the results (expressed as a percentage of trajectories contacting) estimated by the OSRA model of a hypothetical very large spill contacting habitats that are important to seal species.

The OSRA model estimates that trajectories from the LI or PL could contact ERAs or GLSs important to ice seals. The OSRA model results, unless otherwise noted, are expressed as percent of trajectories contacting within 1 and 360 days during summer, winter, and annually (Table 4.7.6-1).

4.7.6.2.7. Bearded Seals (Threatened)

Bearded seals are less common in the Beaufort Sea compared to the Chukchi Sea, occurring around coastal areas during summer, they are also more common near the ice front and in areas of drifting sea ice than in large expanses of open water. Since they forage for benthic species, bearded seals must associate with continental shelf waters, and so their population densities tend to be higher in the Chukchi Sea and lower in the Beaufort Sea which has a narrow continental shelf zone. Though the Chukchi Sea has a large continental shelf area, the shelf in the Beaufort Sea tends to be narrow and ultimately the water depths suitable for prolonged bearded seal occupancy may determine the presence and numbers of bearded seals in the Beaufort Sea. Consequently, in some years bearded seals in the Beaufort Sea may forage farther from the ice front than those in the Chukchi Sea. The number of resident bearded seals in the Beaufort Sea is estimated at around 3,150 as compared to the estimated 27,000 residing year-round in the Chukchi Sea (Cameron et al., 2009), though both resident populations are considered to be part of the Beringian Distinct Population Segment (DPS) of bearded seals.

Grouped Land Segments were not analyzed for bearded seals because this species is strongly associated with sea ice and generally are not found on the shoreline. During winter months their presence is strongly linked to polynyas, areas of broken ice, and lead systems where they can access water and food resources. During summer bearded seals do not aggregate, spending much of their time foraging at sea. Throughout the year bearded seals avoid nearshore areas including areas of landfast ice. The ERAs for seals were described in Appendix A, Table A.1-76. The OSRA model results, unless otherwise noted, are expressed as percent of trajectories contacting between 1 and 360 days during summer, winter, and annually (Tables 4.7.6-1 and 4.7.6-2).

No ERAs, or LSs reserved for bearded seals had $\geq 5\%$ contact probabilities.

4.7.6.2.8. Ringed Seals

As with bearded seals, ringed seals have a strong association with sea ice. However, ringed seals prefer to overwinter in landfast ice, particularly where heaves and irregularities create icy hummocks

that protect their lairs from polar bears. During summer, ringed seals associate with sea ice in the open waters and so may occur in the open ocean where they forage on fishes. It is assumed that their presence and densities in any given area depends upon the food stocks in a local area, as well as the presence or absence of sea ice. Consequently, no GLS, ERA or BS was identifiable for ringed seals; however, they do concentrate in polynyas and lead systems if those features are available. The OSRA model results are expressed as percent of trajectories contacting between 1 and 360 days during summer, winter, and annually (Tables 4.7.6-1, 4.7.6-2, and 4.7.6-3).

No ERAs, LSs, or GLSs reserved for ringed seals had $\geq 5\%$ contact probabilities.

4.7.6.2.9. Ribbon Seals

Very low numbers of ribbon seals have been detected during marine mammal surveys in the Chukchi Sea, and none in the Beaufort Sea (Funk et al., 2010; Bles et al., 2010; Brueggeman et al., 1991, 2009, 2010). Ribbon seals spend most of their lives in the open ocean, relying on sea ice to whelp and molt, then returning to the water for the remainder of the year. Most ribbon seals are found in the southern and western regions of the Chukchi Sea, and are sometimes observed in the eastern and east-central Chukchi Sea, and rarely a ribbon seal is observed near Point Barrow, Alaska. Whelping occurs in the Bering Sea, and perhaps in a few areas of the southern Chukchi Sea, and so there should be little risk to ribbon seals from the a VLOS. Any ribbon seals that could be affected by a VLOS would be in the open water, in very low densities.

Limited observations of ribbon seals in the Chukchi Sea preclude the designation of ERAs, GLSs, LSs, or BSs for ribbon seals. At most, less than one hundred ribbon seals could be affected by a VLOS at the LI. If a VLOS occurred, a fraction of the ribbon seals could be killed, while the remainder would likely recover within a few days. Such effects would not affect ribbon seal stock in U.S. waters.

No ERAs, LSs, or GLSs reserved for ribbon seals had $\geq 5\%$ contact probabilities.

4.7.6.2.10. Spotted Seals

Spotted seals are summer visitors to the Chukchi Sea and to a much lesser extent, the Beaufort Sea. Their primary haulout sites in the Chukchi Sea include Kasegaluk Lagoon, areas around Kotzebue Sound, and some areas along the Chukotka coast, particularly Kolyuchin Bay. The number of seals using haulout sites in the Beaufort Sea are small by comparison to some Chukchi Sea haulouts, which support thousands of spotted seals. Verified spotted seal haulouts in the Beaufort Sea include Dease Inlet/Admiralty Bay, Smith Bay, the Sagavanirktok River Delta, and Oarlock Island in the eastern Colville River Delta. Possible haulouts may also occur on the shore of western Camden Bay, Alaska, but have not been verified. In the following analyses the appropriate ERAs, LSs, and GLs are analyzed to estimate the percentage of trajectories contacting spotted seal habitat in the proposal area. During the Arctic summer spotted seals are not as strongly associated with ice as are bearded and ringed seals, and most use nearshore and coastal habitat. From late fall through late spring spotted seals reside at the southern edge of the winter sea ice front in the Bering Sea and could not be affected by a VLOS.

As with bearded, ringed, and ribbon seals, any VLOS in open-water conditions is likely to contact some individual spotted seals; however, slicks would weather and disperse over time. The VLOS analyzed in the OSRA could be expected to contact less than two hundred spotted seals in the Beaufort Sea or perhaps even a few thousand spotted seals in the Chukchi Sea. The largest aggregation of spotted seals that could be oiled occurs in Kasegaluk Lagoon (ERA 1) between Icy Cape and Wainwright, SUA: and Peard Bay (ERA 64), both of which lie along the Chukchi Sea coastline. Smaller haulout areas occur in along the Beaufort Sea coastline at Smith Bay (ERA65), Harrison Bay (ERA68), Harrison Bay/Colville Delta (ERA69), Kolyuchin Bay (GLS 148), Smith Bay Spotted Seal Haulout (GLS 169), and Harrison Bay Spotted Seal Haulout (GLS 173) (Table A.1-76).

The OSRA model results, unless otherwise noted, are expressed as percent of trajectories contacting between 1 and 360 days during summer, winter, and annually (Table 4.7.6-5).

Summer. ERA 68 has 5% of being contacted by trajectories after 30 days, and ERA and a 6% chance of contact from the LI within 90 days and 360 days (Tables A.2-23 and A.2-24). ERA has a 6% chance of contact from the LI at 90 days. No other ERAs, LS, or GLSs had contact probabilities $\geq 5\%$. No ERAs, LSs or GLSs had annual or winter contact probabilities $\geq 5\%$, and so are not reasonably foreseeable.

4.7.6.2.11. Conclusion

In the event of a VLOS, ice seals could be affected to varying degrees depending on distribution, activity, number affected, season, and various spill characteristics.

Spotted seals are the only phocid species in the analysis area that habitually use shore-based haulouts. Their largest haulout location most likely to be affected by a VLOS lies in the Colville River Delta. Kasegaluk Lagoon may be the largest haulout location that could be affected, and is several times larger than all others combined, but should not be contacted from a VLOS at the LI or PL. Though spotted seals forage for fishes in nearshore areas, their presence is not known to be strongly correlated with pelagic areas and the ice front during summer. Consequently, their presence is associated with haulout areas and nearshore areas with open water. In a 2014 survey by BPXA spotted seals were the most frequently observed marine mammal at the site for the proposed LDPI.

Both bearded and ringed seals closely associate with sea ice throughout the year, and do not typically use shore habitat. Both species prefer to remain in proximity to the ice front during summer, though some use open-waters areas away from sea ice. Bearded seals feed on benthic organisms in shallow (<200 m depth) areas on the continental shelf (ADF&G, 2016), while ringed seals forage for fishes and some invertebrates in the water column. These differences in food selection and foraging behavior help determine the presence or absence of each of these species in an area. Bearded seals are essentially restricted to areas over the continental shelf and the ice front where they can reach the seafloor to feed on benthic organisms, while ringed seals may be found under areas of solid ice as well as in the ice front where they predate fishes such as Arctic and saffron cod.

Ribbon seals are a pelagic ice seal species that have not been documented in the Beaufort Sea east of Point Barrow, and so are highly unlikely to occur near the LDPI. Even in the northern Chukchi Sea biological surveys have only observed them occasionally. Because of their scarcity in the northern Chukchi Sea, and absence from the Beaufort Sea, the ribbon seal population should remain unaffected by a VLOS from the LDPI.

Presently there are no areas identified as important ringed, bearded, or ribbon seal habitat during the summer months. However, during the winter, conditions change drastically with the southward advance of sea ice, when only bearded and ringed seals persist in the Chukchi and Beaufort Seas.

During winter, bearded seals loosely congregate around polynyas, and lead systems, generally avoiding areas of landfast ice. Ringed seals, select landfast ice zones as their preferred habitat where they survive by making and maintaining breathing holes through the ice and by constructing subnivean lairs. A VLOS contacting a polynya or lead systems could therefore have moderate to major effects on ringed and bearded seal populations, potentially oiling or even killing hundreds to thousands of bearded and/or ringed seals. The impacts would be determined by the number of ringed or bearded seals exposed in oiled leads or polynyas. The numbers of seals using an oiled lead system or polynya would likely be a function of the time of year, food resources, and lead or polynya size. For example, if 10,000 adult ringed seals and their pups happened to be using the a lead system during April and that lead system were to become oiled from a VLOS, the effects would likely be major, with many thousands of seals dying from crude oil exposure, especially ringed seal pups.

A contrasting example would be if a VLOS occurred during February when most ringed, and bearded seals, and all spotted, and ribbon seals are overwintering in the Bering Sea. In this example a few thousand ringed seals would probably be at risk of being contacted with spilled crude oil. While a percentage of those seals would likely die, the numbers of fatalities could not approach what was described in the first example because of the numerical difference of adult seals using the leads, and the fact that female ringed seals have yet to whelp. Seal pups are the demographic group most likely to succumb to oil spills, and their absence from lead systems would reduce the number and proportion of mortalities in the population. Furthermore, in such an event there would be no spotted or ribbon seal mortalities and most likely negligible levels of effect to any spotted or ribbon seals due to their absence from the area.

Potential effects of a VLOS event on fishes and invertebrates are analyzed in greater detail in Sections 4.7.3 and 4.7.4. Because ice seals rely on these organisms for food, any major impacts on fishes or invertebrates could have serious consequences to seal populations. A massive die off of prey species would most likely cause seals to leave the area to seek food elsewhere. While such movements would entail some energetic cost, it is unlikely many seals would immediately starve to death. Displaced seals would compete with seals elsewhere for limited food resources, perhaps lowering the overall fitness of a local population, or even contributing to population losses through malnutrition. Consequently, a VLOS has the potential to affect large numbers of ringed, bearded, and spotted seals in part due to the effects their prey and the local food-web, but not that many ribbon seals. Mortality from a hypothetical VLOS could result in temporary population-level effects for bearded, ringed, and spotted seals, but not ribbon seals due to their scarcity in the northern Chukchi Sea. Most of these effects would correct within a generation; however, due to differences in generation times between species, such recoveries could easily take over five years.

Because of the low probability of VLOS materials contacting any ringed or bearded seal ERAs, LSs, or GLSs it is highly unlikely a VLOS from LI or PL would affect more than one hundred ringed, bearded, or spotted seals, and based on trajectories, no ribbon seals would likely be affected. The greatest effect from a VLOS would occur within Stefansson Sound during summer, and affect a few ringed, bearded, and spotted seals. Spill response and cleanup activities would likely displace some of those affected seals, making them to relocate to other, quieter, less busy areas unaffected by the activity or the VLOS materials.

4.7.6.3. Pacific Walrus (Candidate species)

A VLOS could affect Pacific walrus at sea, on sea ice, or at coastal haulouts. Effects could result from direct contact with oil, inhalation or exposure to toxic fumes from the oil (such as PAHs), ingestion of oil or contaminated prey, habitat loss, or prey loss. Additional effects could occur during cleanup and well control work. These impacts could include inhalation or exposure to toxic fumes from cleanup products, disturbance at important on ice or terrestrial haulout sites, disturbance at important foraging sites, and destruction of prey species.

The impacts that occur during each phase of a blowout and subsequent cleanup are analyzed below. The most direct impacts would occur as a result of the oil spilled offshore and onshore. The most recent estimate of the Pacific walrus population suggests a minimum of 129,000 walrus (Speckman et al., 2011). Some researchers believe that the population may be in decline based on age structure and productivity information (Garlich-Miller, Quakenbush and Bromaghin, 2006) due to changes in sea ice and prey availability (Taylor and Udeitz, 2014). The Pacific walrus is a candidate for listing under the ESA due to the continuing loss of sea ice habitat caused by climate change (76 FR 7634, Feb 10, 2011). With a population in decline, any loss of large numbers of walruses, walrus habitat, or prey species would exacerbate that decline. Recovery would not occur unless the population begins to rebound from other factors that may be limiting population productivity or growth, such as decreasing sea ice extent, prey availability or harvest.

4.7.6.3.1. Initial Event

The initial phase could include a large explosion of natural gas and a fire. The bermed perimeter of the proposed LDPI would muffle much of the lateral noise, directing most of the noise from an explosion vertically. Nonetheless, there is some potential for any Pacific walrus in the vicinity of the explosion to experience adverse effects to their hearing. If walrus were in close enough proximity to be able to hear the explosion, they may experience TTS or PTS, depending upon their proximity and the sound level of the explosion, and they may also be frightened into a panic and leave the area. During stampedes from coastal or ice floe haulouts, calves and smaller walrus are the most vulnerable to injury; however the low number of Pacific walrus in the Beaufort Sea would prevent any such instances from occurring. Falling ash and debris could also injure or haze walrus away from the area; however an explosion on the proposed LDPI should remain mostly contained on the island. Furthermore, the structure of the island would prevent an explosion from affecting benthic invertebrates in the area.

4.7.6.3.2. Offshore Oil Spill

Most Pacific walrus in the Arctic remain in the Chukchi Sea during winter and overwinter in the Bering Sea, and only a few of them forage in the Beaufort Sea during summer. For this reason few Pacific walrus in the Beaufort Sea should be affected by a VLOS originating at the LI or PL. Exposure to oil or associated fumes could cause respiratory distress and inflammation of mucous membranes and eyes, leading to damage such as abrasions and ulcerations. Walrus, which have large protruding eyes, would be particularly vulnerable. Walrus rely primarily on a thick layer of blubber for insulation and therefore are unlikely to suffer from hypothermia as a result of oiling. However, they could experience skin inflammation and ulcers as a result of oil exposure. Studies have found that tissue damage can occur if walrus ingest oil or oil contaminants (Kooyman, Gentry and McAlister, 1976). Ringed and Bearded seals have the ability to metabolize small amounts of hydrocarbons so that such tissue damage is temporary unless the exposure is chronic over time (Kooyman, Gentry and McAlister, 1976). Although similar studies have not been done with walrus, their physiology is consistent with that of other Arctic seals. If walrus share this ability, some short term impacts may be mitigated. Chronic exposure may still result in lethal effects or long term sub-lethal, fitness-reducing effects.

Walrus at haulouts have been shown to be very sensitive to smells. Walrus may avoid oil or oiled ice due to the smell, or may remain in the area in spite of the presence of oil. Studies on other seal species have indicated that seals intent on feeding will not avoid an area due to oil or oil sheens (Geraci and St. Aubin, 1990). Oil may impede the ability to dive by increasing buoyancy, which would in turn increase the energy expenditures of feeding, particularly for younger, smaller walrus. The VLOS scenario analyzes 27° American Petroleum Institute (API) oil, a light weight of oil. In general, lighter oils dissipate more quickly through evaporation, dissolution and dispersion. For comparison, the oil spilled in the *Exxon Valdez* Oil Spill was a medium weight of oil. Oil, especially heavy oils and weathered tarry oil, may impede swimming and diving by adhering to the walrus hide and reducing the ability of the animal to move its flippers efficiently. Sand, gravel or other debris may adhere to the oiled skin further impeding locomotion and impacting the walrus' ability to use their vibrissae to locate prey items along the sea floor.

Walrus primarily feed on benthic invertebrates, such as clams and marine worms. Benthic invertebrates that come into contact with the spill would ingest hydrocarbons from water, sediments and food. Invertebrates could concentrate contaminants because they metabolize hydrocarbons poorly. Long-term or chronic oil ingestion may result in kidney damage, liver damage, or ulcers in the digestive tracts of walrus. Depending upon the level of impacts to benthic invertebrates, walrus could be forced to travel farther to forage, resulting in increased energetic costs and perhaps increased competition among walrus for food sources.

4.7.6.3.3. Onshore Contact

Depending upon the location of the spill site and other factors, oil could contact shore within 10 days of the initial event. Walrus could come into contact with oil at coastal haulouts. Regardless of whether contact occurred at sea, on ice or on land, the results to the physical health of the walrus would be the same as those described in 4.5.7.3.2. If walrus avoid coastal areas that have been fouled by oil, they may be excluded from important coastal resting areas once the sea ice retreats off of the continental shelf in late summer. Walrus cannot remain at sea indefinitely; they must haul out to rest and regain body heat. Calves and young walrus are more restricted in the amount of time that they can spend at sea, and unable to swim as far or for as long as adult walrus. This worst-case scenario should not produce population-level effects since most onshore contacts would occur in the Beaufort Sea where Pacific walrus are rare.

4.7.6.3.4. Spill Response and Cleanup Activities

Spill response and cleanup activities would involve large numbers of boats of various sizes, skimmers, airplanes, and helicopters. In-situ burning and corralling oil with boom material, or booming off sensitive nearshore habitats may occur. Although the Alaska Regional Response Team (ARRT) has not pre-approved the use of dispersants in the Arctic, they could be considered on an incident-specific basis. Dispersants could be ingested by benthic invertebrates, and have impacts similar to oil if ingested by walrus. Depending upon the type of chemical dispersant used, dispersants could also cause direct impacts to walrus by irritating eyes, mucous membranes, or respiratory systems. Dispersants could also cause effects by killing prey species and displacing walrus from foraging or resting areas.

In the initial aftermath of a spill, activity would be concentrated in the immediate area of the spilled oil. Walrus would likely avoid the area due to the large amount of noise and activity. Walrus, particularly females with young calves, are easily displaced by boat and aircraft traffic. This displacement which may reduce the likelihood that they would be oiled or be exposed to PAHs which tend to evaporate relatively quickly (within a few days, unless frozen into ice). Gas (primarily methane and ethane) would quickly dissipate into the atmosphere at the spill site and walrus are not likely to be exposed to gas in the event of an explosion and spill. Immediate responses, in addition to seeking to control the well and stop the flow of oil, may include attempts to cap the flow or repair the rupture. In-situ burning has been shown to be very effective with freshly spilled oil, but the oil becomes more difficult to ignite as it ages and the aromatic hydrocarbons burn or evaporate. In-situ burning would release soot and other pollutants into the air, but it is unlikely that walrus would remain in the vicinity of such activity or be exposed to enough smoke and soot to suffer respiratory effects.

As the spill response continues, the oil (and thus the response) would become spread out over a larger area. Walrus are particularly vulnerable to disturbance events at coastal haulouts, which can result in increased mortality, particularly among calves, (Udevitz et al., 2013). If the spill occurs between November and May, walrus would already have moved out of the Beaufort Sea and could not be impacted by oil or cleanup efforts during that season (Jay, Fischbach and Kochnev, 2012; USGS, unpublished tagging data).

Even after the flow of oil has been stopped, responders would continue cleaning any remaining oil that can be located. Cleanup efforts could focus on oiled shoreline, and hot washing methods or dispersants could be used. The coastlines being cleaned would be unavailable to walrus for resting. Dispersants may cause skin irritations, respiratory impacts or impacts to sensitive tissues around the eyes, nose, or mouth. This process may be continued the year following the spill. Oil frozen in ice over winter would melt out in the spring through brine channels and into leads and polynyas.

4.7.6.3.5. Long Term Recovery

After cleanup efforts have ceased, the remaining oil would continue to weather and be subject to microbial degradation. This process is likely to be very slow in Arctic waters. Oil that has been suspended in the water column or in the sediment may continue to be ingested by the benthic organisms that walrus prey upon. Walrus may continue to be exposed to hydrocarbons through their prey, which may lead to reduced fitness and possibly population-level effects over time.

Damage assessment studies would occur as a part of the natural resource damage assessment (NRDA) process. Depending upon the types of studies conducted, some may lead to increased disturbance of walrus by adding additional boat, plane, and shoreline traffic to the Chukchi Sea.

4.7.6.3.6. Oil-spill Trajectory Analysis

This OSRA analysis focuses on terrestrial walrus haulout locations at along Chukchi Coastlines, on Wrangel and Kolyuchin Islands. There are no documented haulout areas for Pacific walruses along the Beaufort Sea coastline. Historically Pacific walrus summer haulouts occur on Wrangel Island and the Chukotka coastline; however in recent years they have been hauling out in large numbers along the U.S. side of the Chukchi Sea coast particularly near the community of Wainwright (Jay, Fischbach, and Kochnev, 2012). BOEM also has additional information about at sea distribution from tagging studies and surveys, and has developed new ERAs that more accurately identify which areas are truly important to Pacific walruses. Where practicable, BOEM uses ERAs and GLSs rather than land segments to delineate terrestrial haulouts so.

Though a VLOS could contact offshore or onshore areas where walrus may be present, there were no instances where VLOS contact probabilities were $\geq 5\%$. Consequently, trajectories indicate there is $<5\%$ likelihood that any ERAs, LSs, or GLSs important to Pacific walruses would be contacted by VLOS materials from the LI (Tables 4.7.6-3, 4.7.6-4, and 4.7.6-5). For this reason it is unlikely and not reasonably foreseeable that any spilled VLOS materials would contact areas biologically important to Pacific walruses.

4.7.6.3.7. Conclusion

In the event of a VLOS, the OSRA model estimates it is extremely unlikely any Pacific walrus habitats outside of the Beaufort Sea would be contacted. Though there are some walruses that enter the Beaufort Sea during summer, sightings of such individuals are rare, while the bulk of the walrus population hauls out on the Russian side of the Chukchi Sea. Between the small numbers of walruses using the Beaufort Sea, the stock distribution during summer, and the low likelihood of Pacific walrus ERA/LS/GLS contacts by a VLOS the Pacific walrus stock should remain unaffected by a VLOS from the LI. Due to the scarcity of walruses in the Beaufort Sea, particularly near the proposed LDPI, no more than 10 walruses should be affected by the a VLOS from the LI, and only during summer when walruses would be present in the Chukchi and Beaufort Seas, coinciding with the only time when a VLOS could potentially disperse over a broad area of the ocean.

4.7.6.4. Polar Bears (Threatened)

Polar bears are listed under the ESA as threatened throughout their range. A VLOS could affect polar bears and polar bear critical habitat on sea ice, barrier islands or on the coast.

Effects could result from direct contact with oil, inhalation or exposure to toxic fumes from the oil (such as PAHs), ingestion of oil or contaminated prey, habitat loss or a lack of available prey. Additional effects could occur during cleanup. These impacts could include inhalation or exposure to toxic fumes from cleanup products, fouling of fur, disturbance at important on ice or terrestrial sites, and continued contamination or loss of prey species or contamination of important coastal or sea ice habitats.

The impacts that occur following a blowout and subsequent cleanup are analyzed below. The most direct impacts would occur as a result of offshore oil spill and onshore contact, which entail an offshore oil spill and onshore contact.

4.7.6.4.1. Initial Blowout Event

The initial phase would likely consist of a large explosion of natural gas and a fire. The impact producing factors that might affect polar bears would be the explosion itself (depending upon the size of the explosion) and the smoke and debris resulting from the fire. Drilling at the proposed LDPI could occur year-round, so polar bears might be in the area if the explosion occurred. Because of the bermed perimeter of the LDPI, much of the lateral noise from an explosion would be buffered and directed upwards; however any polar bears swimming or crossing ice in the vicinity of an explosion could be affected.

4.7.6.4.2. Offshore Oil Spill

Polar bears mostly rely on their subcutaneous layer of fat for insulation when swimming and rely on both fat and fur for insulation when out of the water. Consequently, any oiling could compromise the insulative value of their fur. Hurst and Oritsland found polar bear pelts were similar to those of sea otters and fur seals in terms of the loss of insulation once oiled (Hurst and Oritsland, 1982). Once oiled, polar bears could also ingest oil while grooming which could lead to renal, hematological, and biliary complications, and exposure to fumes from VLOS materials could cause respiratory distress, mucous membrane and eye inflammation, and ulcerations. High levels of exposure could result in death, while chronic low level of exposures may result in long term sub-lethal effects that reduce fitness. Polar bears could also ingest oil by eating oiled seals or carcasses, with results similar to those described for grooming oiled fur.

Polar bears rely primarily on ringed and bearded seals as prey in the Beaufort Sea, but they will also take beluga, and regularly scavenge carcasses of harvested bowhead whales and other marine mammals that have died of natural causes. Polar bears have been observed biting cans of snowmobile oil and neoprene bladders of fuel. One polar bear died as the result of eating a car battery, while another died after ingesting ethylene glycol (Geraci and St. Aubin, 1990; Amstrup et al., 1989). Consequently, there is nothing to suggest polar bears scavenging on oiled seal carcasses would refrain from ingesting lethal doses of oil. Studies on seals indicate that individuals intent on feeding will not avoid an area due to oil or oil sheens (Geraci and St. Aubin, 1990). Polar bears may pursue seals into oiled waters. Though ringed and bearded seals have some ability to metabolize and eliminate hydrocarbons (Kooyman, Gentry and McAlister, 1976) long term or chronic oil ingestion may result in kidney damage, liver damage, or ulcers in the digestive tracts of seals and any polar bears that feeding on them.

4.7.6.4.3. Onshore Contact

Depending upon the location of the spill site and other factors, BOEM has estimated that oil could contact shore within 10 days after a VLOS. Polar bears could come into contact with oil as they move along the coast or barrier islands, or while moving between shore and the ice edge. Regardless of whether contact occurred at sea, on ice or on land, the results to the physical health of the polar bear would be the same as those described for offshore oil spills. If polar bears avoid coastal areas that have been fouled by oil, they may be excluded from important travel corridors to feeding, resting or denning areas, which could impact fitness or reproduction.

4.7.6.4.4. Spill Response and Cleanup

Spill response and cleanup activities would involve large number of boats of various sizes, skimmers, and aircraft. In-situ burning and corralling oil with boom material, or booming off sensitive nearshore

habitats may occur. Although the ARRT has not pre-approved the use of dispersants in the Arctic, they could be considered on an incident-specific basis.

In the initial aftermath of a spill, activity would be concentrated in the immediate area of the spilled oil. Because of the location of the proposed LDPI, some polar bears could be resting or foraging along the coast or on nearby barrier islands, and a few might be swimming through an area exposed to VLOS materials. A study of polar bear reactions to snowmobiles found reactions differed by sex and age class. Smaller bears and females with cubs reacted more often with avoidance behavior than did adult males or single adult females (Anderson and Aars, 2008), so the smaller individuals and females with cubs should be more likely to avoid an area where spill response activities occur. In contrast, hungry, or nutritionally stressed polar bears might be attracted to the spill response activity or engaged in scavenging the carcasses of marine mammals that have died from exposure to VLOS materials. Increased activity in polar bear habitat (e.g., vehicle travel over tundra or sea ice) may increase the likelihood of disturbance to maternal dens. Additional human-polar bear interactions could result in an increase in polar bear take through hazing or in defense of human life. It may be possible to sedate and capture oiled polar bears, and to clean their coats. However, if such bears had already ingested oil, they might be less likely to survive.

Both ringed seal distribution and ice conditions affect polar bear densities and a VLOS could affect this important prey species. Polar bear populations have been observed to increase or decline as seal populations increase or decline (Stirling, 2002), therefore, impacts to ringed seal populations from a VLOS would also impact polar bear populations. Polar bears hunt ringed seals in spring leads, pack ice, fast ice, and at their breathing holes and dens. In spring, polar bears preferentially hunt pups in lairs (Stirling and Archibald, 1977). The potential for exposure to oil that has overwintered increase through these hunting techniques.

After the VLOS has been stopped any remaining oil that can be located would be collected and removed. Cleanup efforts could focus on oiled shorelines, where hot washing methods could be used.

4.7.6.4.5. Long Term Recovery

After cleanup efforts have ceased, any remaining oil would weather and experience microbial degradation while VLOS materials suspended in the water column or in sediments may continue to be ingested by the benthic organisms bearded seals and walrus prey upon. Ringed seals are less likely to accumulate hydrocarbons through the fish that they eat (Geraci and St. Aubin, 1990). Polar bears consuming bearded seals or walrus may continue to be exposed to hydrocarbons through their prey, which may lead to reduced fitness over time.

Damage assessment studies would occur as a part of the NRDA process. Depending upon the types of studies conducted, some may lead to increased disturbance by adding additional boat, plane and shoreline traffic to the Beaufort and Chukchi Seas.

4.7.6.4.6. Oil-spill Trajectory Analysis

A VLOS could contact offshore or onshore areas where polar bears may be present. The degree of contact with oil would depend upon the location, timing, and magnitude of the spill. The OSRA model uses the Liberty Island (LI) to model the spill trajectories of up to 4,610,000 bbl of materials spilled over a 90 day period (Section 4.5.2).

Drilling from the proposed LDPI would occur year round, and the estimated time to drill a relief well is 90 days based on the amount of time needed to mobilize a second drilling rig, drill the well, and kill the blowout. A VLOS occurring during winter would be unlikely to spread to many areas, especially those in the Chukchi Sea, while a summer spill could be more widely dispersed.

Thetis, Jones, Cottle, and Return Islands (ERA 92) was the only ERA where trajectories indicate contact probabilities $\geq 5\%$. Summer contact probabilities for ERA 92 were from 5 to 11% at 10 to

360 days for spills originating at LI. Summer contact probabilities for ERA 92 for spills originating at PL were 5% for 90 and 360 days. Winter and annual contact probabilities were between 7 and 10 % for the 10 to 360 day time periods and only from the LI (Table 4.7.6-3). No LSs had trajectories that contacted $\geq 5\%$, and so there is a $\geq 95\%$ likelihood that no LSs for polar bears would be contacted by a VLOS (Table 4.7.6-2).

The Foggy Island Bay (GLS 179), 104-129 Fall (GLS 178), 98-129 Summer (GLS 176) and 110-124 Winter (GLS 180) showed trajectory contacts $\geq 5\%$. During summer GLSs 176, 178, and 179 were contacted by VLOS materials originating at LI or the PL with probabilities ranging from 12% to 78%. During winter GLSs 176, 178, and 179 showed contact probabilities between 9 and 77% from 3 to 360 days. Winter contact probabilities for GLSs 176, 178, and 179 on day 1 were between 9 and 51% for a VLOS originating at the PL, and GLS also showed a 21% contact probability for a VLOS originating at the LI (Table 4.7.6-5). No other GLSs, and no LSs had contact probabilities $\geq 5\%$, and so are not reasonably foreseeable.

4.7.6.4.7. Conclusion

The majority of the CBS stock is believed to den and come ashore on the Russian side of the Chukchi Sea, particularly at Wrangel Island. The majority of the SBS stock of polar bears come ashore and den further eastward in the Beaufort Sea. However, there is a large area of overlap between the CBS stock and the SBS stock out on the sea ice in the northeastern portion of the Chukchi Sea. If a VLOS were to occur, it could result in the loss of some polar bears, most probably along GLSs 176, 178, and 179, and less likely, ERA 92. This might not have a major impact on the SBS and/or CBS polar bear stocks, especially after considering the trajectories of a VLOS from the LI. In all likelihood much of the effects of a VLOS would be felt in Foggy Island Bay and not in the Chukchi Sea, or throughout most of the Beaufort Sea for that matter. For this reason some polar bears could be affected by a VLOS from the proposed LDPI, however massive area-wide effects are not anticipated. The effects to the SBS and CBS polar bear stocks are anticipated to be moderate.

4.7.7. Effects of a VLOS on Terrestrial Mammals

Impacts to terrestrial mammals from a hypothetical oil spill were analyzed in Section 4.3.5. Those analyses found terrestrial mammals could experience mortality, long-term and short-term sublethal impacts. The primary difference between the effects from a VLOS and those of a large or small spill are in the greater magnitude of the potential effects associated with a VLOS. Most Environmental Resource Areas (ERAs), Land Segments (LSs), and Grouped Land Segments (GLSs) have less than a 5% probability of being contacted by any fraction of materials from a VLOS at the LDPI. Based on the assumption that a $\leq 5\%$ probability of contact indicates a $\geq 95\%$ probability of no contact occurring, only those ERAs, LSs, and GLSs experiencing a $\geq 95\%$ contact probability are analyzed for terrestrial mammals. The limited diameter and length of the pipeline would prevent a potential VLOS event from occurring along the pipeline by restricting the potential volume of a spill. A VLOS occurring during winter, when the LI would be surrounded by solid sea ice, would prevent terrestrial mammals, other than the occasional Arctic fox, from being contacted by spilled materials. Consequently caribou, muskox, and grizzly bears could not be affected by a VLOS during winter.

When responding to a VLOS, response contractor(s) would work with USCG, NMFS, and State of Alaska authorities on wildlife management. In an actual spill, the aforementioned groups would likely have a presence at the Incident Command Post to review and approve proposed activities and monitor their impact on marine mammals. Specific terrestrial mammal protection activities would be employed as the situation requires and modified as needed to meet current needs. In all cases long-term recovery to pre-spill abundance, distribution, and productivity is likely, but recovery period might vary, and require access to unaffected/restored habitat during the recovery period.

4.7.7.1. Phase 1: Well control incident, offshore spill, and onshore contact

The hypothetical VLOS scenario would begin with a well-control incident resulting in a blowout and its immediate consequences. This phase would not affect caribou, and does not evaluate an oil release, or the effects of supporting aircraft or vessels; which are analyzed in Phase 2 and Phase 4, respectively.

The potential impacts of the initial event on terrestrial mammals would likely be limited to the effects of smoke from spill materials burning at the proposed LDPI, contacting spilled VLOS materials in coastal areas, or in the case of Arctic foxes, on the fast ice near the LDPI. Any terrestrial mammal within the plume of smoke could be affected, with the level of impact related to the volume of smoke produced and environmental conditions during the fire. Wind strength and direction would be key elements determining the direction of the smoke plume, the amount of smoke reaching the shoreline, and the degree to which the plume is dispersed before reaching the shoreline. Larger species such as grizzlies may be affected to a greater extent than smaller species such as Arctic foxes, which typically occupy ground-level habitats that tends to be clear of smoke. Larger mammals, while potentially more exposed to the smoke plume, would also be more capable of avoiding the smoke plume by moving from its path. It is unlikely that smoke from the proposed LDPI could reach the shore without dispersing, considering distances between the proposed LDPI and the coastline.

Offshore Spill

Terrestrial mammals by definition occur in onshore areas. Some terrestrial mammals may be affected by killing or scavenging prey contaminated by oil. Contamination may then be passed on through the food web potentially resulting in short- and/or long-term health impacts. These impacts were described in more detail in Section 4.3.5.

Onshore Contact

In the event that oil from a VLOS reaches shore, caribou populations could be impacted if VLOS constituents contaminate coastal insect relief areas during the peak (mid-July thru late August) insect harassment period. The muskox, grizzly bear, and Arctic fox populations should not experience major impacts, though a few individuals could potentially die from contacting spilled hydrocarbons. Direct contact with oil and contamination of food items could have short- and/or long-term impacts to animal health. A loss of foraging areas or food resources could result in animals shifting to alternate diet resources, or malnutrition if there are not enough edible resources remaining to maintain adequate health.

Loss of other important habitat (e.g., scavenging, insect relief, and calving areas) could cause some behavioral changes, but would be unlikely to disrupt local populations. As described in Section 4.3.5, tissue irritation and hypothermia are possible effects of heavily oiling on animals. The greatest direct contamination risk would arise from ingestion of oil through food and grooming of oiled fur, and inhalation of oil constituents in the air. Ingested oil can result in numerous health effects, depending on the quantity of oil consumed and the physical and chemical state of the oil at the time of ingestion.

Loss of food resources by the animal populations that depend on them could result in the animals seeking alternate sources of nutrition that may be less nutritious or less available than those they typically use. The search for replacement food items may lead affected animals into unfamiliar or less frequently used areas where they may come into conflict with resident animals in the unaffected areas over available resources or be subject to increased predation. Loss of food resources could result in a decrease in nutritional status for affected animals, impacting overall fitness and survival.

During winter caribou other than the Teshekpuk Lake Caribou Herd (TCH) and those in Tuktoyaktuk migrate to wintering grounds south of the ACP. Meanwhile grizzly bears hibernate at inland denning

sites and muskox settle in to their smaller winter home ranges in riparian areas. Conversely Arctic foxes take to the sea ice where they wander great distances seeking food such as ringed seal pups, or carrion from polar bear kills.

An oil spill affecting salmon populations and reducing the size of spawning runs, while directly impacting species such as brown bears through the reduction or elimination of a food source, could have an indirect impact on caribou, and muskox. Salmon runs provide an annual nutrient surge linking marine and terrestrial ecosystems (Reimchen et al., 2003), and the loss of this seasonal nutrient input could reduce the quality and quantity of riparian vegetation, reducing the forage base for ungulates. In addition to being a source of food, streamside vegetation also provides shelter for muskox.

4.7.7.2. Phase 2: VLOS response and cleanup

Spill response activities could increase disturbance in the affected area, potentially driving some animals into alternate and less suitable habitat, which in turn may result in reduced nutrition, increased energy expended in foraging, increased predation, and increased competition over habitat and food resources. Spill response activities would involve the use of vessels and aircraft, resulting in increased activity at shore bases and airports. Spill response activities may increase the possibility of encounters between cleanup crews and animals into whose habitat the cleanup crews intrude. Many of the areas likely to be contacted by oil in summer are river deltas and beaches heavily used by caribou, brown bears, and Arctic foxes, while a winter VLOS would most likely affect the shorefast ice immediately surrounding the proposed LDPI. The presence of cleanup crews in these areas may deny access to caribou, muskox, grizzlies, or Arctic foxes what rely on foods occurring in contaminated areas.

Owing to the high nutritive value of resources such as carrion, bears and Arctic foxes may be unwilling to forsake the area and perceive cleanup crews as competitors or prey. Actions would be taken to protect the safety of cleanup crews, which may result in reduced access to bears, possible tranquilization, relocation, or killing of “problem animals.” Impacts of oil spill response activities affecting salmon streams may be reduced to some extent if bears are able to relocate to stretches of river not impacted by cleanup activities.

Deployment of in-situ burning operations would primarily occur near the localized origination point of the spill and in prioritized nearshore areas. Effects on all terrestrial mammal species from these operations are likely to be minor since most burning would occur near the source of the spill; however, nearshore operations, noise, and sensitive coastal sites could remain important to terrestrial mammal species. Burning in nearshore areas would discourage any terrestrial mammal species from remaining in the area, considering their innate fear of fire. For this reason in-situ burning would have negligible effects on any terrestrial mammal species.

VLOS cleanup activities include the use of air support to transport people and materials to and from contaminated areas. The noise and disturbance from aircraft would have effects similar to those described in 4.3.5. Another effect from aircraft noise and disturbance would be the displacement of caribou from areas where aircraft would be operations, such as contaminated stretches of coastline. Though there would be some energetic costs to caribou from being displaced in such a way, individual animals might benefit by having a lesser likelihood of contacting any spilled hydrocarbons.

Cleanup activities may further impact contaminated habitats, for example killing marsh vegetation or forcing oil deeper into sediments (Mendelsohn et al., 2012) by using inappropriate methods in an attempt to remove contamination. Poaching of some species may increase as a VLOS could affect certain sectors of the economy.

For these reasons ground/on-ice cleanup activities, and aircraft operations would have negligible effects on all terrestrial mammal species as long as minimum altitude flying restrictions (1,000 ft.

AGL) are maintained. Furthermore, any aircraft avoidance by terrestrial mammals would have the benefit of encouraging individual animals to avoid spill areas where aircraft would operate. Disposal of contaminated carcasses (if any), tissues and oil contaminated materials (absorbent pads, protective gear, etc.) would likely be at an authorized disposal site onshore. Negligible effects are anticipated.

4.7.7.3. Phase 3: Post spill and long-term recovery

Animals depending on coastal vegetation to meet nutritional needs would be forced to seek alternative food sources that may be less plentiful and nutritious. Soil contamination may persist for years with toxins transferred to growing plants and on to animals feeding on these plants. Likewise, any contamination in the food web could have long-term ecologic and biologic effects on individual caribou, muskoxen, grizzlies, or Arctic foxes that were exposed to the contents of a VLOS.

While crude oil coating a beach may be removed within a few months by cleanup efforts or via natural processes, contamination of the soil may continue for years. Toxins sequestered in the sediments would likely be ingested by bears or Arctic foxes scavenging coastal food sources such as carrion or beach castings. Salmon eggs in natal streams could absorb toxins deposited within the sediments, causing mortality or mutation of fish larvae (Peterson et al., 2003). The indirect long-term effects of a substantial decrease in salmon populations could result in a loss of important nutrients in some area rivers, causing a decrease in streamside vegetation, which serves as food and habitat for terrestrial mammal species (Reimchen et al., 2003). The overall level of effects of the post spill activities and long-term recovery would likely remain negligible, after considering the added effect of coastal erosion on lessening the potential for spilled VLOS materials to remain in the soil.

Long Term Recovery

Over the long term, terrestrial mammals other than caribou would not likely experience population level effects from a VLOS. The low numbers and widespread distribution of most species would make any population-level effects improbable under the worst circumstances. Caribou populations, particularly the smaller populations in Western Canada, would be more likely to experience adverse population level effects from a VLOS if they were to contact the spilled materials during a period of insect relief (mid-July through late August) when large numbers of animals enter coastal waters to escape biting insects. Such effects could take anywhere between one year to many years to recover, depending on the population size, number of individuals exposed, and the severity of exposures. The long-term effects on grizzly bears, muskox, and Arctic foxes would most likely recover within a year or two since they occur in low numbers which are widely dispersed (grizzly bears and muskox), or because they are extremely prolific (Arctic foxes).

Oil-spill Trajectory Analyses

A hypothetical VLOS could contact GLSs where terrestrial mammals may be present. The location, timing and magnitude of a VLOS and the concurrent seasonal distribution and movement of caribou, muskox, grizzly bears, or Arctic foxes would determine whether or not contact with the oil could actually occur. The Oil-spill Risk Analysis (OSRA) models oil-spill trajectories from the Liberty Island (LI). While a VLOS originating at the proposed pipeline was modeled, such an event could not actually occur since the pipeline would be incapable of producing the minimum volume for the modeled VLOS.

This section describes the results estimated by the OSRA model for a hypothetical VLOS originating at the proposed LDPI contacting specific Environmental Resource Areas (ERAs), Land Segments (LSs), or Grouped Land Segments (GLSs) that are important to terrestrial mammals. ERAs, LSs, and GLSs are spatial representations (polygons) that indicate a geographic area important to one or more terrestrial mammal species. The effectiveness of oil-spill response activities is not factored into the results of the OSRA model.

The following discussion presents the results estimated by the OSRA model of the hypothetical VLOS contacting areas important to terrestrial mammal species. The dynamics of oceanographic, climatic, and biotic factors affecting the distribution and abundance of prey, timing of accessibility to habitats, and corridors for movement determine the opportunity for terrestrial mammals to contact spilled VLOS materials. Trajectory contact with any ERA/LS/GLS does not indicate the entire area is oiled, or that all of the spilled hydrocarbons ended up in that area, only that the area was contacted somewhere by some amount of spill materials from the VLOS.

Only those contacts where $\geq 5\%$ of the trajectories contacted the ERA/LS/GLS are analyzed below. Any contacts below $< 5\%$ indicate there is over $> 95\%$ confidence that the area would not be contacted in the event of a VLOS based on the modeled trajectories. Contact probabilities $< 5\%$ are therefore considered so unlikely as to be unforeseeable. No ERAs or LSs were contacted in the OSRA model and only a few GLSs were contacted with any regularity (Appendix A, p A.53-A.80)

Table 4.7.7-1. Summer Conditional Probabilities for Terrestrial Mammal GLSs.

ID	GLS	1 day LI	3 day LI	10 day LI	30 day LI	90 day LI	360 day LI
167	TCH Insect Relief/Calving	<0.5	<0.5	<0.5	4	5	5
174	CAH Insect Relief/Calving	12	28	40	42	42	42
183	PCH Insect Relief/Calving	<0.5	<0.5	<0.5	1	1	1

Table 4.7.7-2. Winter Conditional Probabilities for Terrestrial Mammal GLSs.

ID	GLS	1 day LI	3 day LI	10 day LI	30 day LI	90 day LI	360 day LI
167	TCH Insect Relief/Calving	<0.5	<0.5	<0.5	1	2	2
174	CAH Insect Relief/Calving	6	14	20	22	22	22
177	Beaufort Muskox Habitat	<0.5	1	4	5	5	5

Table 4.7.7-3. Annual Conditional Probabilities for Terrestrial Mammal GLSs.

ID	GLS	1 day LI	3 day LI	10 day LI	30 day LI	90 day LI	360 day LI
167	TCH Insect Relief/Calving	<0.5	<0.5	<0.5	2	3	3
174	CAH Insect Relief/Calving	7	17	25	27	27	27
177	Beaufort Muskox Habitat	<0.5	<0.5	<0.5	4	4	4

Caribou

GLS 167 (TCH Insect Relief/Calving, MAP A-4b) had a 5% contact probability at 90 and 360 days from a summer VLOS event. GLS 174 (CAH Insect Relief/Calving, MAP A-4b) had a 12%-42% contact probability from a summer VLOS event between days 1 and 360, a 6%-22% contact probability from a winter VLOS event between days 1 and 360, and Annual Conditional contact probabilities of 7%-27% between days 1-360.

Muskox

GLS177 (Beaufort Muskox Habitat, MAP A-4b) was had Winter Conditional Probabilities of 5% at 30, 90, and 360 days. The Annual Conditional probabilities for GLS 177 were 7%-27% between days 1-360.

Grizzly Bear

No GLSs for grizzly bears were contacted with $\geq 5\%$ of the simulations.

Arctic Foxes

No GLSs for Arctic foxes were contacted with $\geq 5\%$ of the simulations.

Conclusion

Direct contact with spilled oil resulting from a VLOS would have the greatest potential to affect CAH, and to a much lesser extent TCH caribou engaged in calving or during the insect harassment

period. If large numbers of caribou were to enter water contaminated by materials from a VLOS there could be a large number of individuals directly affected, and the effects of such an event could take many years to recover from. For this reason a VLOS event at the proposed LDPI would likely have a moderate level of effects on caribou.

Muskoxen could be affected along the Beaufort Sea coastline; however, they occur much more sporadically and in much smaller groupings that do caribou. Furthermore, muskox are sedentary, and are not prone to traveling extensive distances as caribou do. For this reason only a few muskoxen, at most, could reasonably be expected to come into contact with hydrocarbons released in a VLOS event. Consequently, a VLOS should not produce any population-level effects on muskoxen, and would most likely have a negligible level of effects on muskox on the ACP.

Similarly, grizzly bears are widely distributed across the ACP, but only as individuals or females with cubs, and without the large aggregations observed in the southern areas of Alaska where immense runs of salmon can support greater concentrations of individuals. If a VLOS were to occur a small number, probably less than 20 bears would likely be affected as they scavenged for carrion and edible beach castings. During winter the grizzly bears would be hibernating in inland areas, away from the coast and should remain unaffected by a VLOS. For this reason, a VLOS event would most likely have a minor level of effects on grizzly bears.

As with grizzlies, Arctic foxes are distributed across the ACP; however, they remain active throughout the years, venturing out onto the sea ice in the winter to scavenge and hunt ringed seal pups. During summer some Arctic foxes would likely come into contact with VLOS materials when scavenging in coastal areas, and in winter they could encounter contaminants on the shorefast ice. In either circumstance several individuals could die; however, unlike the other terrestrial mammals on the ACP, Arctic fox fecundity should permit the population to recover within a year, or two years at the most. For this reason, the level of effects of a VLOS on Arctic foxes is expected to be minor.

4.7.8. Effects of a VLOS on Vegetation and Wetlands

Contamination of coastal vegetation and wetlands would likely occur during a VLOS and associated cleanup efforts. The potential for spilled oil to contact vegetation and wetland environments is influenced by timing of a VLOS, the seasonal effects of currents and subsequent advection of oil, timing and duration of oil spill, presence or absence of fast or pack ice, and general weather patterns (wind and storm events). The Beaufort Sea shoreline is characterized by small tides and moderate winds of the region (Section 3.2.6), creating a low potential for spilled oil to reach beyond the intertidal area. However, seasonal storm events could force oil into upper shoreline areas into wetlands and inside delta areas as far inland as 5,000 m along the Beaufort Sea (Reimnitz and Maurer, 1979). Placement of booms around sheltered embayments and streams where diadromous and marine fish species congregate could prevent loss of fish, their habitat, and benthic communities that support their ecosystems. The occurrence of shore fast ice along the coastline of the Beaufort Sea prevents the growth of aquatic macrophytes in many littoral areas.

4.7.8.1. Phase 1 (Well Control Incident, Offshore Spill and Onshore Contact)

At Phase 1, direct exposure to oil is an impact producing factor that can affect vegetation and wetlands. The potential of oil from a VLOS contacting the coastal vegetation and wetlands would be dependent upon timing of a VLOS, the seasonal effects of currents and subsequent advection of oil, timing and duration of oil spill, presence or absence of fast or pack ice, and general weather patterns (wind and storm events). The amount of impact would be a function of the size of the oiled area and the duration of the VLOS.

Oil stranded on beaches may occur on the surface, or it could penetrate into subsurface layers. Permeable substrates, generally associated with larger sand grain sizes, and holes created by infauna could increase oil penetration, especially that of light oils and petroleum products. Oil will not penetrate the water-saturated sediments; however, in areas of high suspended sediment concentrations, the oil and sediments could mix, resulting in the deposition of contaminated sediments on the flats. (NOAA, 2010). Penetration into coarse-grained sand beaches may allow oil to penetrate and accumulate in the soil (Pezeshki et al., 2000). Light oils may penetrate peat shores; however, peat resists penetration by heavy oils (NOAA, 2010). Although any residual oil that could remain following cleanup might be largely removed in highly exposed locations through wave action, oil could remain in the shallow subsurface for extended periods of time. In some locations, oil might become buried by new sand or gravel deposition. Natural degradation and persistence of oil on beaches are influenced by the type of oil spilled, amount present, sand grain size, degree of penetration into the subsurface, exposure to weathering action of waves, and sand movement onto and off shore. Although petroleum-degrading microbial communities are present, biodegradation along Arctic coastlines would likely be slow (Prince, Owens and Sergy, 2002; Braddock, Lindstrom and Price, 2003) and is limited to only a few months per year. Spilled oil could persist for many years, with continued effects on potential recovery (Owens et al., 1983; Braddock, Lindstrom and Price, 2003; Owens, Taylor and Humphrey, 2008). On sheltered beaches, heavy oiling left for long periods could form an asphalt pavement relatively resistant to weathering (Hayes et al., 1993). Lagoon shorelines include low-energy beaches where spilled oil would likely persist for many years. Spilled oil may persist for extended periods on peat shores; however, if cleaned up, it would be expected to persist for less than a decade (Owens and Michel, 2003). If the spill reached shoreline areas, the probability of adverse impacts on the tundra and marshes would depend on wind and wave conditions. Due to the low tidal range typical in such environments, stranded oil would be subject to low rates of abrasion and dispersal by littoral processes.

Oil deposition above the level of normal wave activity would occur, if the spill takes place during spring tides or during storm surges. In such case, oil stranded in emergent vegetation is expected to persist for long periods due to the low rates of dispersion and degradation. Impacts would include the destruction of emergent vegetation, if the oil slick sinks into the root system and reduces oxygen exchange between the atmosphere and the soil (Stebbing, 1970; Caudie and Maricle, 2014). Impacts to wetlands from a VLOS oil slick in the vicinity of the coast during a storm surge could result in injury or mortality of vegetation and invertebrates in or on the substrate. Other effects of spills could include a change in plant community composition or the displacement of sensitive species by more tolerant species. Impacts to soil microbial communities might result in long term wetland effects, and wetland recovery would likely be slowed. Impacts to wetland vegetation may cause plant mortality and loss of wetland areas.

Various factors influence the extent of impacts to wetlands. Impacts would depend on site-specific factors at the location and time of the spill. The degree of impacts are related to the oil type and degree of weathering, the quantity of the spill (lightly or heavily oiled substrates), duration of exposure, season, plant species, percentage of plant surface oiled, substrate type, soil moisture level, and oil penetration into the soil (Hayes et al., 1992; Hoff, 1995; NOAA, 2010; Pezeshki et al., 2000). Higher mortality and poorer recovery of vegetation generally result from spills of lighter petroleum products (such as diesel fuel), heavy deposits of oil, spills during the growing season, contact with sensitive plant species, completely oiled plants, and deep penetration of oil and accumulation in substrates. Vegetation regrowth and recovery are generally better where oil spills occur in flooded areas or on saturated soils, than on unsaturated soils (BLM, 2002). Coastal wetlands in sheltered areas (such as embayments and lagoons) and that are not exposed to strong water circulation or wave activity, would be expected to retain oil longer with longer-lasting effects on biota (Culbertson et al., 2008).

4.7.8.2. Phase 2 (Spill Response and Cleanup)

Spill cleanup operations might adversely impact coastal beaches if the removal of contaminated substrates affects beach stability and results in accelerated shoreline erosion. Vehicular and foot traffic during cleanup could mix surface oil into the subsurface, where it would likely persist for a longer time (Hoff, 1995). Manual cleanup rather than use of heavy equipment would minimize the amount of substrate removed due to effects of motorized vehicles on fragile tundra soils. Skimming, booming, in-situ burning, and other spill response and cleanup operations can be effective means of preventing offshore oil spills from reaching coastal wetlands and other vegetation. However, spill response activities could also disturb, trample, or otherwise damage these resources through the transportation and use of equipment. In addition to mechanical cleanup and recovery activities, additional response strategies such as the use of dispersants could be employed and intentionally introduced into the environment, likely at the sea surface, and applied using aircraft or vessels. Dispersants may have an adverse effect on coastal and estuarine habitats depending upon the type of dispersant and its fate in the coastal ecosystem. The effects from these activities would be similar to the temporary impacts associated with pipeline construction, onshore construction. These temporary losses of vegetative resources would be minimized through appropriate spill response planning and protocols.

4.7.8.3. Phase 3 (Post-Spill, Long-Term Recovery)

Long-term is defined as an effect that affects populations for more than 2 years. Long term effects are possible for coastal areas due to severity of the VLOS and OSRA projections. Storm surges are a concern. In 1970, Reimnitz and Maurer (1979) observed the effects of tidal surges from a major storm event that inundated low-lying tundra and delta regions on the Beaufort Sea shoreline, leaving debris lines from flotsam as far as 5,000 m (16,500 ft) inland. A storm of equal or greater magnitude could force weathered oil far inward and leave residue over wide areas of tundra and river shores. In such cases, full recovery of wetlands, including invertebrate communities, may require more than 10 years depending on site and spill characteristics (Culbertson et al., 2008). Oil could remain in some wetland substrates for decades, even if it was cleaned from the surface. Heavy deposits of oil in sheltered areas of coastal wetlands or in the supratidal zone could form asphalt pavements resistant to degradation (Culbertson et al., 2008).

4.7.8.4. Oil Spill Trajectory Analysis

Conditional and Seasonal Chance of Contact

The majority of Land Segments (LSs) would have less than a 5% chance of being contacted by a large oil spill. The effects of a large offshore spill on vegetation and wetlands include oil-fouling, smothering, asphyxiation, and poisoning of plants.

If a large spill were to oil onshore wetlands along the coast of Foggy Island Bay during the summer season, oil spill cleanup personnel would trample vegetation while removing some of the oil from the shoreline. Gravel shorelines such as the Endicott causeway, where adsorption booms could be effective in oil recovery, can preclude oil from contacting western channels of the Sagavanirktok River Delta. Cleanup of contaminated-oiled wetlands would be difficult. Oil removal by mechanical means would alter or destroy vegetation, and flushing techniques could drive some of the oil into the soil and roots, smothering wetland plants. The OSRA model estimates 1 to 50% chance of a large spill contacting sheltered vegetated low banks, salt/brackish water marshes, and inundated low-lying tundra that 1 to 30 days and 90 to 360 days (Table 4.3.6-2) assuming a spill $\geq 1,000$ bbl occurs at the Island Launch Area (LA) or Pipeline LA. Only LS105 and LS106 would have more than a 5% change of being contacted by a large oil spill during the summer. While a large oil spill occurring during winter would have more than 5% change of contacting LS107 (includes Tigvarik Island and Shaviovik River), as well as LS105 and LS106.

LS105 includes Point Brower, the Sagavanirktok River and Duck Island and is immediately to the west of the LDPI (LS106). The Endicott Causeway is within LS105; the causeway is a manmade physical barrier with two breaches. Depending upon conditions it is conceivable for spill response booms and skimmers to be positioned along the eastern side of the causeway to intercept an oil spill and limit contact with wetlands of the western channels of the Sagavanirktok River Delta and Duck Island.

Summer Season Day 1 to Day 30. The OSRA model estimates a 17 % to 33% chance of LS105 being contacted by a large oil spill originating from the LDI LA, and a 15% to 24% chance of LS105 being contacted by a large oil spill originating from subsea pipeline LA. LS106 would have a 6% to 20% chance of being contacted by a large oil spill originating from the LDI LA; and a 37% to 49% chance of LS106 being contacted by a large spill originating from the subsea pipeline LA.

Summer Season Day 90 and Day 360. The OSRA model estimate a 33% chance of LS105 being contacted by a large oil spill originating from the LDI launch area of the spill, and a 24% chance of LS105 being contacted by a large oil spill originating from the subsea pipeline LA. LS106 would have a 20% chance of being contacted by a large oil spill originating from the LDI LA; and a 49% chance of LS106 being contacted by a large spill originating from the subsea pipeline LA.

Winter Season Day 1 to Day 30. The OSRA model estimates a 14 % to 28% chance of LS105 being contacted by a large oil spill originating from the LDI LA, and a 13% to 21% chance of LS105 being contacted by a large oil spill originating from the land or subsea portion of the pipeline LA. LS106 would have a 6% to 22% chance of being contacted by a large oil spill originating from the LDI LA; and a 36% to 50% chance of LS106 being contacted by a large spill originating from the land or subsea portion of the pipeline LA. LS107 would have a 7% to 8% chance of being contacted by a large oil spill originating from the LDI LA; and a 6% chance of LS107 being contacted by a large spill originating from the land or subsea portion of the pipeline LA.

Winter Season Day 90 and Day 360. The OSRA model estimate a 28% chance of LS105 being contacted by a large oil spill originating from the LDI launch area of the spill, and a 21% chance of LS105 being contacted by a large oil spill originating from the land or subsea portion of the pipeline LA. LS106 would have a 22% chance of being contacted by a large oil spill originating from the LDI LA; and a 50% chance of LS106 being contacted by a large spill originating from the land or subsea portion of the pipeline LA. LS107 would have a 8% chance of being contacted by a large oil spill originating from the LDI LA; and a 6% chance of LS107 being contacted by a large spill originating from the land or subsea portion of the pipeline LA.

Table 4.7.8-1. Summer or Winter Fraction of a Large Oil Spill Contacting Land Segments with Sheltered Vegetated Low Banks, Salt/Brackish Water Marshes, or Inundated Low-Lying Tundra.

Season / Analysis Period	% Range to LSs ≥1%	LS IDs with any value ≥1%
Summer 1, 3, 10, and/or 30 days	1-5% at 14 LSs; 6-49% at 2 LSs	LS88, LS91, LS92, LS93, LS99, LS100, LS101, LS102, LS103, LS104, LS105, LS106, LS107, LS108, LS109, LS110, and LS112
Winter 1, 3, 10, and/or 30 days	1-5% at 9 LSs; 6-50% at 3 LSs	LS92, LS100, LS101, LS102, LS103, LS104, LS105, LS106, LS107, LS108, LS109, LS110
Summer 90-360 days	1-5% at 16 LSs; 30-49% at 2 LSs	LS85, LS88, S91, LS92, LS93, LS99, LS100, LS101, LS102, LS103, LS104, LS105, LS106, LS107, LS108, LS109, LS110, and LS112
Winter 90-360 days	1-5% at 13 LSs; 6-50% at 3LSs	LS85, LS88, LS91, LS92, LS93, LS99, LS100, LS101, LS102, LS103, LS104, LS105, LS106, LS107, LS108, LS109, LS110, and LS112

Notes: LA= Launch Area, LS = Land Segment
 Geographic Name of Land Segments Contacted in Alaska: LS85 Utqiagvik, Browerville, Elson Lag.; LS88 Cape Simpson, Piasuk R.; LS92 Cape Halkett, Garry Creek; LS93 Atigaru Pt., Eskimo Isl., Kogru R.; LS100 Milne Point, Simpson Lag.; LS101 Beechy & Back Pt., Sakonowiyak R.; LS102 Kuparuk R., Pt. Storkersen; LS103 Pt. McIntyre, West Dock, Putuligayuk R.; LS104 Prudhoe Bay, Heald Pt.; LS105 Pt. Brower, Sagavanirktok R., Duck I.; LS106 Foggy Island Bay, Kadleroshilik R.; LS107 Tigvariak Island, Shaviovik R.; LS108 Mikkelsen Bay, Badami Airport; LS109 Bullen, Gordon & Reliance Pts.;

LS110 Pt. Hopson & Sweeney, Thomson; LS111 Staines R., Lion Bay; LS112 Brownlow Point, West Canning River

Expressed as a percent of chance of a Large Oil Spill contacting a certain LS within 30 days, and 90 to 360 days during summer or winter from the proposed LDPI LA and the Pipeline LA.

Sources: Appendix A, Table A.2-2, Map A-3C, Figure 4.7.8-1,

Sheltered Vegetated Low Banks. Only LS101 (Beechy and Back Points, Sakonowiyak River) has 5% or more sheltered vegetated low banks (Table A.1-1 column 9B). There would be a 1% to 2 % chance that this LS101 with habitat of this description would be impacted by a large oil spill.

Salt/Brackish Water Marshes. Five LSs (LS101, LS105, LS106, LS108, and LS109) have 5% or more salt/brackish water marshes (Table A.1-1 column 10A). There would be a 1% to 3% chance that LS101(Beechy and Back Points, Sakonowiyak River) and LS109 (Bullen Point, Gordon Point and Reliance Point) with habitat of this description would be impacted by a large oil spill. Salt/brackish water marshes comprises 15% of LS105, 8% of LS106, and 3% of LS107; the chance that these three LSs are discussed above for large oil spills.

Inundated Low-Lying Tundra. Habitat of this description is the most of the 18 LSs that have a chance to be contacted by a large oil spill and have 5% or more inundated low-lying tundra. They are LS85, LS88, LS92, LS93, LS99, LS100, LS101, LS102, LS103, LS104, LS105, LS106, LS107, LS108, LS109, LS110, LS111, and LS112. The OSRA model estimates that within 90 days (Table 4-7.8-1) only at LS105, LS106, and LS107 would have more than a 5% chance of a large oil spill contacting inundated low-lying tundra.

Overall, the effects of a large spill on the LSs with the vegetation and wetlands considered by the OSRA would not differ for the Proposed Action or Alternatives 3, 4A, 4B, 5A, 5B, or 5C.

The following paragraphs present the results (expressed as a percent of trajectories contacting) estimated by the OSRA model of a hypothetical very large oil spill contacting coastal areas. The probability of an oil spill contacting the coastal areas would depend on the location, timing, and magnitude of the spill, ocean currents, weathering, etc. The OSRA model uses 2 launch areas (LAs) to model the origination of spill trajectories. The Beaufort Sea summer season (open-water season) lasts from 15 July to October 31, and is when any drilling related spills would occur. In the unlikely event of a loss of well control, BOEM has determined from 39 to 74 days would be required for another drillship to transit to the site and drill a relief well. In the event of a VLOS not all of the hydrocarbons are discharged at once. They flow into the ocean at rates that decrease over time. For the briefest spill period BOEM assumed that a spill has a 3 week discharge window, and so a 60 day period of potential contact was analyzed. However if a spill were to occur late in the open-water season, the liquid hydrocarbons may freeze into the sea ice, and remain overwinter without any extensive amount of weathering. If this were to happen un-weathered oil could be transported to non-spill zone areas in the Chukchi and Beaufort Seas and be released in the spring. To address concerns such as this BOEM has also analyzed a spill window of 360 days. A VLOS continuing after 31 October is treated as a winter spill. Oil could still be released during this period, so 360-days is the most conservative assessment period for this hypothetical situation.

The intertidal and subtidal coast of the Beaufort Sea lack vegetation and are summarized here as coastal barrens. The predominance of shore fast ice along these shorelines precludes most vegetation and benthic fauna from establishing themselves on the coastal barrens. The coastal barrens include the following 13 shorelines types: exposed rocky shore; exposed solid man-made structures; exposed wave-cut platforms in bedrock, mud or clay; fine to medium-grained sand beaches; tundra cliffs; coarse grained sand beaches, mixed sand and gravel beaches; gravel beaches; exposed tidal flats; sheltered rocky shore and sheltered scarps in bedrock, mud or clay; sheltered solid man-made structures; peat shorelines; sheltered tidal flats; and other shores. Due to the physical components of coastal barrens, lack of fauna and flora, and the presence of underlying permafrost, oil spill slicks may be cleaned more effectively in these areas.

This analysis focuses on coastal areas featuring two valuable vegetation wetland types: sedge/grass, moss wetlands (W1) and sedge, moss, dwarf-shrub wetlands (W2). These vegetation types were described in Section 3.2.6 as onshore/inland vegetative communities. These communities contribute more to the higher trophic-levels and are a higher source of nutrients to the surrounding waters than the coastal barrens because they include vegetation and animal life. Only one other vegetation type is included in the land segments (LS) where OSRA's conditional probabilities indicated onshore contact: tussock-sedge, dwarf-shrub, moss tundra wetland (G4) is a small portion of LS93. W1 and W2 are only considered in the application of the OSRA at Land Segments (LSs) where either one comprised 1% or more chance the VLOS would contact (Table 4.7.8-1).

Table 4.7.8-2. Fraction of a VLOS Contacting Vegetative Wetlands.*

Season / Analysis Period	% Chance Range of LSs \geq 1%	LS IDs with any value \geq 1%
Summer 1 and/or 3 days	1-5% at 5 LSs; 6-48% at 2 LSs	LS103, LS104, LS105, LS106, LS107, LS108, and LS109
Winter 1 and/or 3 days	1-5% at 4 LSs; 6-47% at 2 LSs	LS104, LS105, LS106, LS107, LS108, and LS109
Summer 10-30 days	1-5% at 15 LSs; 6-49% at 2 LSs	LS88, LS92, LS93, LS97, LS99, LS100, LS101, LS102, LS103, LS104, LS105, LS106, LS107, LS108, LS109, LS110, and LS112
Winter 10-30 days	1-5% at 9 LSs; 6-50% at 3 LSs	LS92, LS100, LS101, LS102, LS103, LS104, LS105, LS106, LS107, LS108, LS109, and LS110
Summer 90-360 days	1-5% at 17 LSs; 30-49% at 2 LSs	LS85, LS88, S91, LS92, LS93, LS97, LS99, LS100, LS101, LS102, LS103, LS104, LS105, LS106, LS107, LS108, LS109, LS110, and LS112
Winter 90-360 days	1-5% at 13 LSs; 6-50% at 3LSs	LS88, LS92, LS93, LS100, LS101, LS102, LS103, LS104, LS105, LS106, LS107, LS108, LS109, LS110, LS111, and LS112

Notes: * Land Segments (LSs) with Sedge/Grass, Moss Wetlands (W1), and Sedge, Moss, Dwarf-Shrub Wetlands (W2) during Summer of Winter.

Geographic Name of Land Segments Contacted in Alaska: LS85 Utqiagvik, Browerville, Elson Lagoon; LS88 Cape Simpson, Piasuk River; LS92 Cape Halkett, Garry Creek; LS93 Atigaru Point, Eskimo Island, Kogru River; LS 97 (Kupigruak Channel, Colville River LS99 Oliktok Point, Ugnuravik River; LS100 Milne Point, Simpson Lagoon; LS101 Beechy & Back Point, Sakonowiyak River; LS102 Kuparuk River, Point Storkersen; LS103 Point McIntyre, West Dock, Putuligayuk River; LS104 Prudhoe Bay, Heald Point; LS105 Point Brower, Sagavanirktok River, Duck Island; LS106 Foggy Island Bay, Kadleroshilik River; LS107 Tigvariak Island, Shavirovik River; LS108 Mikkelsen Bay, Badami Airport; LS109 Bullen, Gordon & Reliance Points.; LS110 Point Hopson & Sweeney, Thomson; LS111 Staines River, Lion Bay; LS112 Brownlow Point, West Canning River

W1–Sedge/Grass, Moss Wetlands

During summer the LSs featuring 1% or more chance of the VLOS contacting W1 wetlands include: LS85 (Utqiagvik, Browerville. Elson Lagoon), LS88 (Cape Simpson, Piasuk River), LS91 (Lonely, Pitt Point, Pogik Bay, Smith River), LS92 (Cape Halkett, Garry Creek), LS93 (Atigaru Pt., Eskimo Island, Kogru River) that has a small portion of W1, LS99 (Oliktok Point, Ugnuravik River), LS100 (Milne Point, Simpson Lagoon), LS101 (Beechy & Back Point, Sakonowiyak River), LS102 (Kuparuk River, Point Storkersen), LS103 (Point McIntyre, West Dock, Putuligayuk River), LS104 (Prudhoe Bay, Heald Point), LS105 (Point Brower, Sagavanirktok River, Duck Island), LS106 (Foggy Island Bay, Kadleroshilik River), LS107 (Tigvariak Island, Shavirovik River), LS108 (Mikkelsen Bay, Badami Airport), LS109 (Bullen, Gordon & Reliance Points), and LS110 (Pt. Hopson & Sweeney, Thomson).

During winter the LSs featuring 1% or more chance of the VLOS contacting W1 wetlands include: LS88, LS93 that has a small portion of W1, LS100, LS101, LS102, LS103, LS104, LS105, LS106, LS107, LS108, LS109, LS110, and LS111 (Staines River, Lion Bay) that has approximately equal portions of W1 and W2.

W2 - Sedge, Moss, Dwarf-Shrub Wetlands

During summer the LSs featuring 1% or more chance of the VLOS contacting W2 wetlands include: a small portion of W2 at LS88 (Cape Simpson, Piasuk River), LS93 (Atigaru Pt., Eskimo Island, Kogru River) that also has a small portion of G4, LS 97 (Kupigruak Channel, Colville River), and LS112 (Brownlow Point, West Canning River).

During winter the LSs featuring 1% or more chance of the VLOS contacting W2 wetlands include: a small portion of W2 at LS92, LS93 that also has a small portion of G4, LS111 (Staines River, Lion Bay) with an equal portion of W1, and LS112.

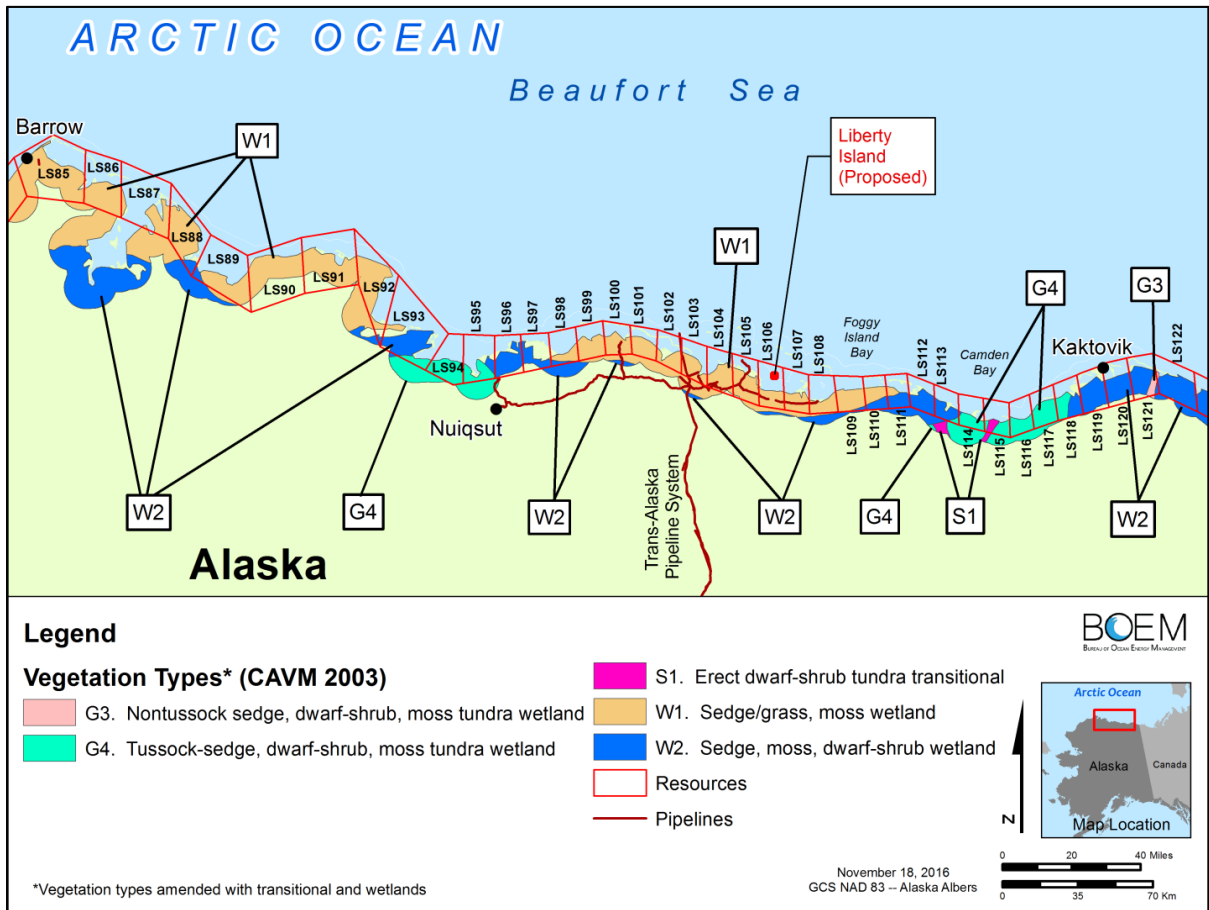

Figure 4.7.8-1. Land segments (LS) and onshore/inland vegetative communities potentially impacted by a VLOS. OSRA LSs have been amended to simplify polygons for a cartographic visual depiction. LSs actually end at the shoreline.

OSRA

The only LSs with coastal areas that would have a 5% chance to as much as a 50% chance of VLOS contact include the Proposed Action Area and immediately adjacent LSs. They include LS105, LS106, and LS107. The onshore/inland vegetative community at these LSs is W1. The coast of these LSs would be contacted if the VLOS occurred during summer or winter; and if the VLOS originated from either the LDPI or from the subsea pipeline. The OSRA model estimates that within 1 to 3 days there is 6-48% chance of the VLOS trajectories contacting LS106; for both the 10 to 30 day and the 90-360 day periods there is 20-50% chance of the VLOS trajectories contacting LS106. Given various oceanographic conditions that result in predominant westward coast currents there is VLOS contact with LS105 than LS107. The OSRA model estimates for LS105 that within 1 day there is 13-17% chance of the VLOS trajectories contact and within 3 days there is 18-27% chance of contact. While

the OSRA model estimates for LS107 that within 1 day there is a 1% chance of the VLOS trajectories contact and within 3 days there is 3-5% chance of contact; for both the 10 to 30 day and the 90-360 day periods there is 4-8% chance of the VLOS trajectories contacting LS107. There is a 1-5% or less chance of the VLOS trajectories contacting 12 other LSs east of the LAs, and the 5 other LSs west of the LAs; those VLOS trajectories contacting LSs beyond LS105, LS106 and LS107 would mostly 30-360 days.

4.7.8.5. Conclusion

Potential impacts from spills would be expected to occur from the direct effects of oil on coastal vegetation and wetlands. Shoreline and inundated areas of vegetation lost to the effects of a VLOS would recover slowly, providing an opportunity for accelerated erosion during recovery time. Wetland areas would be affected if the onshore contact is concurrent with a storm-surge. Oil contamination could persist for 10 years or more during which time the oil in the sediments could be slowly released back into the environment as a result of erosion or exposure of oiled sediments and soils. Response and clean-up efforts have the potential to cause negative effects by exposing shoreline areas to anthropogenic disturbance. Overall, the effects of oil exposure on vegetation and wetlands could take 2-10 years for recovery, depending on severity and duration of a VLOS, and would be considered major.

4.7.9. Effects of a VLOS on Sociocultural Systems

4.7.9.1. Effects of a Very Large Oil Spill on Sociocultural Systems

For this DEIS, BOEM analyzed effects of a Very Large Oil Spill (VLOS) greater than or equal to 4.6 million barrels of oil at the end of 90 days after a catastrophic event such as a loss of well control (Section 4.5). A very large oil spill is a low-probability event with the potential for major effects. BOEM analyzes the potential effects on sociocultural systems for Nuiqsut, Kaktovik and Utqiaġvik from a VLOS originating six miles from shore at the proposed LDPI in Foggy Island Bay. For more details on the effects of a VLOS to subsistence practices and harvest patterns Section 4.7.9.2.

A very large oil spill could affect sociocultural systems in a number of ways (USDOJ, MMS, 2002). Overall effects on subsistence harvest patterns could be major (Section 4.7.9.2) because one or more important subsistence resources could become unavailable, undesirable for use, or available only in greatly reduced numbers for one or more seasons. Any disruption of the bowhead whale harvest from a VLOS or from actual or perceived tainting of the *mataaq* and whale meat anywhere during the bowhead migration and summer feeding could disrupt whaling for an entire season.

If a VLOS contacted and extensively oiled habitats, the presence of hundreds of spill response workers, boats, and aircraft for spill response and cleanup activities would most likely increase the displacement of subsistence resources and alter or reduce access to subsistence resources. These disruptions could lead to a breakdown of kinship networks and sharing patterns and increased social stress in communities. Participating in spill response and cleanup, as local residents did in the *Exxon Valdez* oil spill in 1989, could cause residents to 1) not participate in subsistence activities, 2) have a surplus of cash to spend on material goods, and 3) not seek or continue employment in service positions in their communities. A sudden and dramatic increase in income earned from working on cleaning up the *Exxon Valdez* spill and being unable to pursue subsistence harvests because of the spill caused substantial amounts of social distress and related problems (Fall and Field, 1996; Gill et al., 2011; Impact Assessment, 2001).

A disruption of social organization in the form of sharing networks could lead to a decreased emphasis on the importance of the family, cooperation, and sharing. Multiyear disruptions of subsistence harvest patterns, especially to bowhead whaling, could disrupt sharing networks, subsistence task groups, and whaling crew structures and would most likely severely disrupt the

subsistence way of life. Other effects might be a decreased emphasis on subsistence as a livelihood and an increased emphasis on wage employment, individualism, and entrepreneurship (USDOJ, BOEM, 2015-LS193). Increased social problems, breakdown in family ties, and a weakening of community well-being could lead to additional stresses on the health and social services available in communities. If a VLOS occurred, local employment in spill response and cleanup could disrupt subsistence harvest patterns for one or more seasons and disrupt the function of some formal institutions such as whaling captains' associations. Contemporary subsistence practices and harvest patterns could be severely altered and community infrastructures severely stressed by drawing local workers away from village service jobs. Effects on the sociocultural system from response and cleanup for a VLOS could be major and last for one or more subsistence seasons.

Conclusion. A VLOS starting at the proposed LDPI could threaten some important subsistence harvest areas on which sociocultural systems rely. Of particular importance is the offshore bowhead whaling area used by crews from Nuiqsut (Figure 3.3.3-4; Table 4.4.3-1).

If offshore oil from a VLOS directly contacted migrating or resident marine mammals, seals, fish, caribou, and/or migratory waterfowl, contaminated traditional harvest areas, and persisted in subsistence harvest areas, sociocultural systems would be severely reduced and interrupted, particularly bowhead whale hunting. This could create severe reductions in access to traditional nearshore and offshore harvest areas lasting one or more seasons. Social organization, cultural values, and formal institutions would most likely be disrupted for one or more seasons. Overall, BOEM anticipates impacts to sociocultural systems from a VLOS to be severe and thus major for Nuiqsut.

BOEM anticipates long lasting and widespread impacts from a VLOS on sociocultural systems for Kaktovik and Utqiagvik. Impacts from VLOS spill response and cleanup activities to sociocultural systems could be moderate to major for Nuiqsut, Kaktovik, and Utqiagvik depending on how long cleanup would take and to what extent residents of these communities participated in response and cleanup work. If VLOS cleanup activities persisted longer than one season on the North Slope and resources and manpower were substantially drawn from all three communities, effects to sociocultural systems could become severe and thus major for Nuiqsut, Kaktovik, and Utqiagvik. Overall, BOEM anticipates moderate to major effects to the sociocultural system from a VLOS for Kaktovik and Utqiagvik.

Long-term recovery from a VLOS could severely disrupt sociocultural systems for more than one year, resulting in major impacts in Nuiqsut. Impacts of long-term recovery to sociocultural systems for Kaktovik and Utqiagvik are anticipated to be long lasting and widespread but less than severe and thus moderate.

4.7.9.2. Effects of a VLOS on Economy

For this DEIS, BOEM analyzes effects of a Very Large Oil Spill (VLOS) greater than or equal to 4.6 million barrels of oil at the end of 90 days after a catastrophic event such as a loss of well control (Section 4.5). A VLOS is a low probability event with the potential for major effects. The NSB is a mixed cash-subsistence economy. This section discusses economic impacts from a potential VLOS in terms of traditional measures of employment, labor income, population and revenues; it does not attempt to provide information on the full economic consequences of a VLOS (e.g., valuing injuries to natural resource services that would likely be damaged from a VLOS). For analysis of potential impacts to subsistence-harvest patterns and sociocultural systems, please see Sections 4.7.9.3 and 4.7.9.1, respectively.

Section 4.6.1 characterizes the VLOS scenario into three distinct phases. Of these, phase 2 (Spill Response and Cleanup) and phase 3 (Post-Spill, Long-Term Recovery) are the most relevant to analyzing the economic effects.

As discussed in Section 4.4.2.1, the EVOS spill was 240,000 bbl and generated substantial employment of up to 10,000 workers doing cleanup work. Smaller numbers of cleanup workers returned in the warmer months of each year following 1989 until 1992. During the EVOS, numerous local residents quit their jobs to work on the cleanup, often at significantly higher wages. This generated additional adverse effects in the form of sudden and significant inflation in the local economy (Cohen, 1993). Similar short-term adverse effects on the NSB as a result of a very large spill could be mitigated due to the likelihood that cleanup activities, including administrative personnel and spill-cleanup workers, would likely be housed in existing enclave-support facilities.

Employment, Labor Income, and Population

If a VLOS of 4.6 MMbbl occurred, it would likely generate several thousand direct, indirect, and induced jobs and millions of dollars in personal income associated with oil-spill response and cleanup. The number of workers would likely be much larger than the number of workers who cleaned up the EVOS. See Section 4.6 for assumptions on number of staging locations, vessels, workers, and booming teams involved in response as well as a discussion on how seasonal conditions could affect response and cleanup activities. Based on these descriptions, it is likely that employment during winter cleanup and response would be less than employment for summer cleanup and response operations; however, the overall short-run employment created for response and cleanup would likely be substantial for any season of occurrence. Fewer job losses (i.e. adverse employment/labor income effects) are expected in the NSB or other parts of Alaska because of a VLOS given that there are few other industries in the area that would likely be directly or indirectly impacted. Thus, the net employment/labor income effects are expected to be positive at both the State of Alaska (SOA) and NSB level.

The incremental impact of annual jobs and labor income associated with cleanup and response would represent less than one percent of the total Alaska employment and labor income, and would likely result in little to no effect on employment in other sectors of the SOA economy resulting in a negligible effect.

The effects of employment and labor income on the NSB economy would ultimately depend on the extent to which Borough residents are employed in the cleanup efforts. Given the relatively small size of the existing labor force in the NSB relative to the number of response and cleanup workers that could be employed, the incremental impacts to the NSB economy would likely be major, although the employment and its beneficial economic effects would be short-term in nature.

A VLOS is expected to have negligible beneficial and adverse effects on SOA employment and associated labor income. Response and cleanup workers would likely come from the NSB, other parts of Alaska, and then other States. A VLOS is likely to have little to no impact on the population base of the SOA or the NSB due to the temporary nature of the response and cleanup jobs, physical separation of worker housing, and low likelihood of workers permanently relocating to the NSB.

Revenues

Positive revenue impacts on the SOA and NSB from a potential VLOS would include property tax revenues from any new onshore infrastructure put in place to support cleanup efforts. In addition, a hypothetical VLOS would result in a Natural Resource Damage Assessment (NRDA). The National Ocean and Atmospheric Administration (NOAA) conducts NRDA through a process that includes determination of the injuries from a spill, quantification of those injuries, and then restoration planning. For a description of the approaches and methods that NOAA uses to identify and value injuries to natural resource that have been damaged from an event like a VLOS, please refer to NOAA's Damage Assessment, Remediation, and Restoration Program (U.S. DOC, NOAA, 2017). The result of the NRDA process could have substantial revenue impacts as the population of interest

is compensated for a range of natural resource service values damaged by the hypothetical VLOS and come at a high cost to the responsible parties.

As context, the April 2010 Deepwater Horizon (DWH) oil spill in the Gulf of Mexico resulted in the largest offshore oil spill in U.S. history. The DWH NRDA determined the nature and extent of injury to the nation's natural resources caused by the spill, and the kind and amount of restoration needed to restore the Gulf to the condition it would be in if the spill had not occurred. On April 4, 2016, the court approved a historic \$20.8 billion global settlement agreement with BP, the party ruled primarily responsible for the DWH oil spill. According to the settlement, BP will pay the Trustees up to \$8.8 billion for restoration to address injuries to natural resources. These funds will be used to implement the Trustees' Programmatic Damage Assessment and Restoration Plan and Programmatic Environmental Impact Statement. The plan and associated documents are posted on the Trustees' web site (DWH NRDA Trustees, 2016). The settlement also includes \$5.5 billion in Clean Water Act penalties. As required by the RESTORE Act, 80% of those funds will be directed to Gulf restoration as determined by the RESTORE Council members.

There would also be adverse impacts to SOA revenues if TAPS throughput is reduced because of the oil spill, either through a temporary moratorium on oil and gas activities or space-use conflicts with producing fields. Space-use conflicts may occur because clean up resources would be competing with existing onshore oil and gas operations. Potential space/use conflicts or a moratorium could also delay permitting for other future exploration and production activities that could reduce economic activity in general including employment, personal income, and revenues. Loss of access from congested shipping routes and crowded ports could have a short term adverse effect on Alaska economic output as delivery of goods and services could be reduced. A VLOS could also displace future economic activity that currently is relatively minor or could potentially exist in the Arctic (e.g., a VLOS could limit the opportunities of future jobs and revenues that may be generated by increased marine shipping activities occurring in the region).

The beneficial and adverse effects of a VLOS on SOA and NSB revenues could be substantial. The most notable beneficial effects would result from compensation because of the NRDA process and property tax revenues from any new onshore infrastructure put in place to support cleanup efforts. The magnitude of potential long-term adverse effects is more uncertain; effects would ultimately depend on the degree to which the VLOS affects future economic activities in the SOA and NSB. The potential effects of a VLOS on the SOA and NSB economies are likely to be major.

Conclusion

Table 4.7.9-1 presents the conclusions on economic measures used to analyze the effects of a VLOS on the SOA and NSB economies.

Table 4.7.9-1. Effects of a VLOS on Economic Measures.

Economic measure:	State of Alaska	NSB
Employment / Labor Income	Negligible	Major
Revenue	Major	Major
Population	Negligible	Negligible

A VLOS is expected to have negligible adverse and beneficial effects on SOA employment and labor income, and major effects on revenues. The beneficial impacts on NSB employment, labor income and revenues are likely to be major. A VLOS is likely to have little to no impact on the population base of the SOA or the NSB.

Overall, a VLOS is expected to have a major impact on the SOA and NSB economy.

4.7.9.3. Effects of a Very Large Oil Spill on Subsistence Activities

For this DEIS, BOEM analyzed effects of a Very Large Oil Spill (VLOS) greater than or equal to 4.6 MMbbls of oil at the end of 90 days after a catastrophic event such as a loss of well control. A very large oil spill is a low-probability event with the potential for major effects. In this section, BOEM analyzes the potential effects on subsistence activities and harvest patterns for Nuiqsut, Kaktovik and Utqiagvik from a VLOS originating six miles from shore at the proposed LDPI in Foggy Island Bay.

Adverse effects from a VLOS on subsistence activities and harvest patterns in and around the Proposed Action Area and the communities of Nuiqsut, Kaktovik, and Utqiagvik would most likely be severe and thus major (USDOJ, BOEM, 2015; USDOJ, MMS, 2002). One or more important subsistence resources could become unavailable for one or more seasons due to a VLOS. The adverse and severe impacts would result from direct contact of crude oil with shorelines and resources and the perception of tainting or actual contamination of resources used as subsistence foods and would most likely result in the following outcomes:

- Reduced numbers of species used for subsistence purposes
- Displacement of people from traditional harvest areas
- Displacement of subsistence resources
- Increased competition for subsistence resources
- Loss of or reductions in traditional subsistence practices
- Social and psychological distress over potential losses of cultural values and identities
- Undesirability of subsistence resources as foods and avoidance of oiled resources and areas
- Contaminated resources unfit for human consumption
- Changes in traditional diets
- Decreased nutritional health
- More difficult pursuit of resources resulting in increased harvester effort
- Increased risk and cost of hunting and fishing due to increased travel distances

Phase 1: Well control incident, offshore spill, and onshore contact

During the open-water season, direct impacts of a VLOS on subsistence harvest resources and harvest practices could be immediate and widespread in the initial phases of the blowout event in Foggy Island Bay and the Sagavanirktok River Delta. This is because the proposed LDPI is only six miles offshore and winds and currents from the northeast would most likely push oil to shore relatively quickly. In the winter season with complete sea ice cover, oil from a VLOS may linger on the ice in the vicinity of the proposed LDPI or move relatively slowly away from the proposed LDPI, or spilled oil from a VLOS could linger under the ice and disperse rather slowly in cold Arctic seawater.

Depending on the response time and extent of coverage of the incident by the news media and local social media coverage, the initial impacts of the VLOS on residents of Nuiqsut, Kaktovik, and Utqiagvik from hearing news and viewing images of the event would most likely be severely traumatic for these subsistence harvesters and community residents. This would likely produce long lasting, widespread, and severe stress and anxiety over the safety and availability of resources and accessibility to harvest areas. Community fears about reduced or contaminated food resources, contaminated habitats and harvest areas, reductions in the ability to harvest traditional foods, and concerns related to general food safety would most likely cause social and psychological stress (USDOJ, MMS, 2007).

In this phase, offshore resources, including resources at the surface of the sea, in the water column, and on the sea floor could come into direct contact with spilled oil from a VLOS. Onshore resources

and habitats could also be oiled. Pollution stemming from an oil spill may contaminate environmental resources, habitats, and subsistence food sources. The presence of oil and the initial response to the spill event could prevent or disrupt access to and use of affected subsistence use areas.

Initially, marine mammals such as whales and seals would most likely swim to avoid the spilled oil from a VLOS. North Slope whalers know that bowheads have the ability to smell and avoid areas where oil is present (USDOI, BOEM, 2015). The probability of oil contacting whales is likely to be less than the probability of oil contacting bowhead habitat and traditional harvest areas. The number of whales contacting spilled oil would depend on the location, size, timing, and duration of the spill and the whales' ability or inclination to avoid contact. If oil gets into leads or ice-free areas frequented by migrating bowheads, some portion of the population could be exposed to spilled oil. Whales travelling under the ice or feeding near the bottom could experience contamination.

Oil contamination of beaches, barrier islands, and sea ice would have impacts on marine mammal hunting because Iñupiaq whalers and seal hunters would be unwilling and/or unable to bring whales and seals ashore or onto the ice for butchering. Some harvest seasons could cease until resources were determined to be safe for harvest, sharing, and eating. In the event of a VLOS, all bowhead whaling communities in Alaska could share concerns over the safety of these subsistence foods and the health of the bowhead whale stock. This widespread concern could cause social and psychological stress especially if communities experienced reductions of this culturally preferred food. The loss of opportunities to harvest whales would threaten a pivotal element of indigenous culture on the North Slope. Whaler avoidance due to a VLOS would most likely vary depending on the timing and volume of a spill, persistence of oil in the environment, time necessary for recovery of offshore subsistence use areas, and community confidence that bowhead whales and seals were once again safe to eat. Traditional practices of harvesting, sharing, and processing whales and other marine resources could be severely disrupted if there are concerns over tainting of bowhead whales or their feeding areas. A VLOS could have severe and thus major effects on the subsistence uses of bowheads both within and beyond the Proposed Action Area because of reduced sharing of whale products in the region and the migratory nature of the species (Galginaitis, 2014b; NOAA, 2013).

The effects from a VLOS on ringed and bearded seals could occur from 1) oiling of skin and fur; 2) inhaling hydrocarbon vapors; 3) ingesting oil-contaminated prey; 5) loss of food sources, and 6) temporary displacement from some feeding areas. In general, a VLOS could cause injury or death to seals or cause them to move from of their normal areas making them unavailable for subsistence harvesting for one or more seasons. Impacts to subsistence seal hunting could be major for Nuiqsut hunters and moderate for hunters from Kaktovik and Utqiagvik.

Migratory seabirds and waterfowl used by subsistence harvesters could be most vulnerable during this phase of a VLOS because they spend the majority of their time on the sea surface and often aggregate in dense flocks. Many bird species important to subsistence harvests by the Beaufort Sea communities are associated primarily with coastal areas and in sea ice leads. Impacts to subsistence waterfowl hunting caused by oiling of birds during the offshore spill phase are expected to be severe and thus major for Nuiqsut. For Kaktovik and Utqiagvik, impacts of a VLOS to waterfowl hunting could be moderate.

Terrestrial mammals could be affected by a VLOS to the extent they reside in coastal habitats and feed near contaminated shorelines (USDOI, BOEM, 2015). In June through August, caribou frequent barrier islands and shallow coastal waters during periods of heavy insect harassment; caribou could become oiled and could eat contaminated vegetation as a result of a VLOS. Nuiqsut, Kaktovik, and Utqiagvik hunt for caribou along the coast in July and August and could be severely disturbed by oiled caribou and oiled shorelines. If a VLOS occurred during the open-water season or during winter and subsequently melted out of the ice during spring, caribou frequenting coastal habitats could be directly contaminated by the spill along the beaches and in shallow waters. Contact and

contamination would occur during periods of insect escape activities, usually during summer months. It is likely that many caribou would be deflected from contaminated areas by the presence of people, vessels, and aircraft during spill response and cleanup activities. During late winter and early spring, caribou move out on to the ice, licking sea ice for salt and could be exposed to oil if a VLOS had contaminated the ice. Impacts to subsistence caribou hunting could be major for Nuiqsut and Kaktovik. BOEM expects moderate effects to caribou hunting for Utqiagvik in the event of a VLOS.

A VLOS could affect offshore and nearshore fish species in the path of or near the oil through either acute toxicity or shifts in prey availability. A VLOS contacting intertidal or estuarine spawning and rearing habitats used by subsistence fish could result in impacts to local fish breeding populations. Recovery to a species' former status after a VLOS by dispersal from nearby population segments could require more than three generations and thus, anadromous fish can be particularly impacted if oil reaches the mouth and delta of anadromous streams and rivers. Depending on timing, extent, and persistence of a VLOS, some migratory fish populations could become reduced in number or eliminated. Some local fish stocks could become unavailable subsistence harvests for one or more seasons. A VLOS could have major effects on subsistence fishing for Nuiqsut and moderate impacts on fishing for harvesters from Kaktovik and Utqiagvik.

Oil spills have the greatest potential for affecting large numbers of birds due to toxicity to individual birds, contamination of their prey, oiling of feathers leading to hypothermia, and difficulties involved in oil-spill cleanup in remote areas and a wide variety of vegetative and ice conditions. The loss of groups of waterfowl on the North Slope due to a VLOS would most likely cause harvest disruptions that would be severe for subsistence hunters who regard waterfowl hunts and harvest and sharing of waterfowl to be of primary importance. A VLOS could cause major impacts to goose and eider hunting for Nuiqsut and moderate impacts to goose and eider hunting for Kaktovik and Utqiagvik.

Tainting concerns and both actual and perceived contamination of subsistence food resources as a result of a VLOS could severely curtail the harvesting, sharing, and processing of subsistence resources. These practices could be interrupted for one or more seasons. Subsistence use areas directly oiled and offshore and onshore areas used for staging for oil-spill response and cleanup would most likely not be available for use by subsistence hunters for some time following a spill. Impacts of a VLOS related to tainting and hunter avoidance could be moderate to major for Nuiqsut, Kaktovik, and Utqiagvik.

Phase 2: VLOS response and cleanup

During spill response and cleanup of a VLOS, disturbances to subsistence practices would most likely occur from disruptions to daily life from an influx of outsiders coming to the area to work and staying in communities. There would most likely be increased noise and physical habitat alterations associated with cleanup of a VLOS. Other disturbances to subsistence harvest patterns could come from 1) vessels and aircraft supporting cleanup; 2) noise of drilling relief wells, 3) burning of spilled oil; 4) hazing and capture of wildlife and sending animals to rehabilitation centers; 5) chemical dispersants could be introduced to the marine environment; 6) influx of new job opportunities; and 7) physical washing and cleaning of oil from beaches and shorelines.

Spill cleanup could provide opportunities for local, high paying wage work and could likely displace many local hunters from traditional subsistence pursuits. Cleanup for a VLOS could disrupt subsistence harvest activities for an entire season or more. This disruption would be due to employment of local hunters during cleanup potentially causing them to be unable to take time for traditional hunting and fishing activities.

Spill-cleanup strategies could potentially reduce the amount of spilled oil in the environment and could reduce the effects of contact with crude oil and contamination of subsistence resources. In the

case of a VLOS in winter, fewer subsistence resources would be present and cleanup is likely to be more effective.

Equipment used during spill response and cleanup includes skimmers, workboats, and barges, which could cause whales and seals to be temporarily displaced, altering their migration pathways and causing them to avoid traditional harvest areas. Whales and seals could become more wary and difficult to harvest. The operations of small vessels, cleanup crews, support vehicles, and heavy equipment could disturb coastal subsistence resource habitats, displace subsistence species, reduce hunter access to traditional hunting use areas or species, and alter or extend the annual subsistence hunts for one or more seasons.

During the open-water or breakup seasons, disturbances to and diversion of bowhead whales, seals, caribou, and migratory waterfowl could increase due to spill response and cleanup. Deflection of subsistence resources from the combination of a VLOS and spill response and cleanup activities could persist beyond a single season perhaps lasting several years (USDOJ, MMS, 2007).

Another disruption to hunting activities could be caused by the response of cleanup crews. These crews may require local knowledge, experience, and vessels belonging to whaling captains in the community as expert resources. By utilizing these resources, cleanup crews could divert the whaling captains and their equipment to spill response and cleanup activities with the potential to impact subsistence whaling or other hunting activities due to commitments to cleanup work.

The overall result would be a major effect on subsistence harvests and those in the communities who depend on subsistence. North Slope residents and communities could experience adverse impacts to cultural and spiritual values due to the loss of subsistence resources and harvest opportunities. Residents could experience a decrease in their nutritional health and mental well-being. Impacts from a VLOS from spill response and cleanup activities could be moderate to major depending on how long cleanup would take. Cleanup of the *Exxon Valdez* oil spill took more than four summers (EOSTC, 2014). If cleanup activities persisted longer than one season on the North Slope, effects could become severe and thus major.

Phase 3: Post spill and long-term recovery

In this phase of a VLOS, the impacts to subsistence harvest patterns could occur from 1) unavailability or increased difficulty in obtaining and utilizing subsistence resources; 2) long-term contamination stemming from the oil spill; 3) perceptions that resources are contaminated, altering traditional use patterns; 4) co-opting of human resources and equipment required to study long-term impacts of the spill, and 5) long lasting psychological and social distress in communities.

In the long-term recovery phase, adverse impacts to subsistence resources could transform into sociocultural impacts. Subsistence practices and harvest patterns are closely intertwined with sociocultural systems, socioeconomic, community health, and environmental justice issues. Long-term subsistence impacts during recovery from a VLOS could create a perception of chronic disruptions to social organization in the form of ritualistic harvests and sharing of bowhead whales. Any actual or perceived tainting of the whale *mataaq* and meat as bowhead whales pass through the VLOS area during migration could cause long-term disruptions in patterns and practices of bowhead whaling, which could lead to a breakdown of kinship networks, sharing patterns, and increased social stressors in communities affected by a VLOS (USDOJ, BOEM, 2015). Communities farther from the oil spill area would most likely assist communities affected by a VLOS by sharing subsistence foods with them, potentially taxing the resources of those subsistence regions and communities (USDOJ BOEM, 2015; USDOJ, MMS, 2007).

If local subsistence harvesters were employed in long-term monitoring studies of impacts of the VLOS, their time, manpower, and equipment may be diverted away from subsistence practices or community services. Participation in long-term recovery work on the part of local people could cause

non-participation in subsistence activities and fewer people to seek employment in the community services sectors if spill recovery jobs paid higher wages. Increased income could be beneficial to some families in that having extra cash on hand would allow individuals to purchase fuel and equipment needed for effective subsistence harvests or give cash to family members who have more time for harvesting. Rapid increases in income could have adverse effects as well. Extra cash could be spent on alcohol, less nutritional store bought foods, or families could quarrel over what to do with extra income. or become jealous of families or communities whose incomes increased (Wooley, 1995).

After a VLOS during long-term recovery, communities could experience severe stress and anxiety over the long-term loss of or reduction in subsistence practices, contamination of resources, fear of the health effects of eating contaminated wild foods, fear of changes to harvest regulations, and dependence on the knowledge of outside experts to inform them about levels of environmental contamination and when it would once again be safe to consume traditional foods (USDOJ, BOEM, 2015). Individuals and communities could be increasingly stressed as they modified subsistence harvest patterns and changed harvest areas. If new harvest areas were farther away from communities or unfamiliar, there would be increased safety risks and costs associated with travel and hunting in unfamiliar areas. An affected community would most likely not be able to hunt or fish in someone else's territory without permission. Sociocultural organization of subsistence activities among kinship groups could be disrupted during long-term recovery. Relationships could be weakened among those who customarily process and share subsistence harvests and would most likely need to be modified during long-term recovery

Effects of long-term recovery from a VLOS could adversely impact whaling crew structure and disrupt Inupiaq cultural values central to the subsistence way of life. These disruptions could cause a breakdown in sharing patterns, family ties, and the community's sense of well-being. Sharing linkages with other communities could be disrupted. Long-term recovery from a VLOS could disrupt subsistence harvest patterns for one or more seasons and could cause severe and thus major impacts in Nuiqsut. Impacts of long-term recovery for Kaktovik and Utqiagvik are anticipated to be long lasting and widespread but less than severe and thus moderate.

Oil spill trajectory analysis

Based on conditional probabilities on an annual basis, January through December, a VLOS starting at the proposed LDPI would most likely threaten some important subsistence harvest patterns and practices. The oil from a VLOS could contact subsistence use areas important to Nuiqsut, Kaktovik, and Utqiagvik. The chances of contact are estimated from the conditional probabilities, which represent the percent of spill trajectories launched from the proposed LDPI that could contact an environmental resource area or a subsistence use area (Table 4.7.9 1; Appendix A).

Table 4.6.2-1 summarizes the conditional probabilities for several critical subsistence use areas and resources both annually and for the summer season, July 1 through September 30. BOEM included the summer trajectories because these subsistence use areas are generally more vulnerable during the open-water season because that is when most subsistence activities occur at these places. Ninety days after a VLOS event, there is a chance that 11% of the spill trajectories starting from the proposed LDPI would contact Nuiqsut's bowhead whaling area near Cross Island (i.e., ERA 43); in summer, this increases to 26%. Thetis Island is an important place for seal hunters from Nuiqsut; there is a chance that 10% of the VLOS trajectories would contact and oil Thetis Island (i.e., ERA 92). The stretch of coastline between the Colville River and Canning River Deltas is an important caribou use area that is part of Nuiqsut's and Kaktovik's historic caribou hunting area (i.e., GLS 175). This portion of the shoreline has a chance of being contacted by 13% of the spill trajectories from a VLOS; in summer when these animals are hunted, the chance increases to 42%.

Table 4.7.9-2. Conditional Probabilities for Subsistence Use Areas 90 Days after VLOS.

ID	Description	Annual Probability (%)	Summer Probability (%)
ERA 12	Nuiqsut-Colville River Delta-Fishing, Seal hunting, Waterfowl and Caribou	3	6
ERA 42	Utqiagvik East Arch-Whaling, Seal hunting, Fishing, Waterfowl	1	4
ERA 43	Nuiqsut-Cross Island-Whaling, Seal hunting, Waterfowl	11	26
ERA 44	Kaktovik Offshore-Whaling, Seal hunting, Fishing, Waterfowl	<0.5	1
ERA 92	Nuiqsut-Thetis Island-Seal hunting	10	11
ERA 105	Nuiqsut-Fish Creek-Fishing	3	4
GLS 168	Utqiagvik/Nuiqsut-Summer Caribou	2	5
GLS 175	Nuiqsut/Kaktovik-Summer Caribou	13	42
GLS 183	Kaktovik-Summer Caribou	<0.5	1

Note: 1 ERA = environmental resource area; GLS = grouped land segment, in this case representing stretches of coastline important for caribou hunting.

Source: Appendix A

Conclusion

Based on conditional probabilities a VLOS starting at the proposed LDPI would most likely threaten some important subsistence harvest areas (Table 4.7.9 1).

In Phase 1, if offshore oil from a VLOS directly contacted migrating or resident marine mammals, seals, fish, caribou, and/or migratory waterfowl; contaminated traditional harvest areas; and persisted in subsistence use areas, subsistence practices would be severely curtailed and interrupted, particularly bowhead whale hunting. This could create severe reductions in access to traditional nearshore and offshore harvest areas lasting one or more seasons. Impacts to subsistence activities and harvest patterns are anticipated to be severe and thus major for Nuiqsut.

For Phase 2 of a VLOS, impacts from spill response and cleanup activities could be moderate to major for Nuiqsut, Kaktovik, and Utqiagvik depending on how long cleanup would take and to what extent residents of these communities participated in response and cleanup work. If VLOS cleanup activities persisted longer than one season on the North Slope and resources and manpower were substantially drawn from all three communities, effects could become severe and thus major for Nuiqsut, Kaktovik, and Utqiagvik. Overall, BOEM anticipates moderate to major impacts from a VLOS on subsistence activities and harvest practices for Kaktovik and Utqiagvik.

During Phase 3, long-term recovery from a VLOS could disrupt subsistence harvest patterns for one or more seasons and could cause severe and thus major impacts in Nuiqsut. Impacts of long-term recovery for Kaktovik and Utqiagvik are anticipated to be long lasting and widespread but less than severe and thus moderate.

4.7.9.4. Effects of a Very Large Oil Spill on Community Health

For this DEIS, BOEM analyzed effects of a Very Large Oil Spill (VLOS) greater than or equal to 4.6 million barrels of oil 90 days after a catastrophic event such as a loss of well control from the LDPI. For more details on the effects of a VLOS to subsistence practices, harvest patterns, and sociocultural systems see Section 4.7.9.2. BOEM expects impacts of a VLOS on community health to be similar to impacts from a VLOS on subsistence activities and sociocultural systems because these are the primary determinants of community health in the NSB.

A very large oil spill could adversely affect community health in a number of ways (USDOJ, BOEM, 2015, p. 606). For example, a VLOS could cause adverse impacts to air and water quality, which in turn could have long lasting and widespread effects on community health related to respiratory illnesses and contaminated marine and freshwaters used for hunting and fishing. A VLOS also could severely impact subsistence harvest patterns.

Overall effects on subsistence harvest patterns could be major because one or more important subsistence resources could become unavailable, undesirable for use, or available only in greatly reduced numbers for one or more seasons. Any disruption of the bowhead whale harvest from a VLOS or from actual or perceived tainting of the *mataaq* and whale meat during the bowhead migration route could disrupt whaling for an entire season. Long lasting, widespread and severe impacts could occur to community health due to increased food insecurity, declines in nutritional health, and compromised social organization and cultural well-being.

The arrival and presence of hundreds of oil spill response and cleanup workers, support vessels, and aircraft would most likely increase displacement of subsistence resources and alter or reduce access to subsistence resources. These disruptions could lead to a breakdown of kinship networks and sharing patterns and increased social stress in communities. A disruption of sharing networks could lead to a decreased emphasis on the importance of cooperation and sharing at both the family and community levels.

Multiyear disruptions of subsistence harvest patterns, especially to bowhead whaling, could disrupt sharing networks, subsistence task groups, and whaling crew structures and would most likely severely disrupt the subsistence way of life. This would compromise cultural well-being and could severely and adversely impact community health. Increased social problems, breakdown in family ties, and a weakening of community well-being could lead to additional stresses on the health and social services available in communities. See Section 4.7.9.3 and 4.7.9.1 for additional information about the effects of a VLOS on subsistence harvest patterns and sociocultural systems.

If local residents substantially participated in spill response and cleanup work, as local residents did in the *Exxon Valdez* oil spill in 1989, they could experience both adverse and beneficial effects to their health and well-being. Local employment in spill response and cleanup for a VLOS could disrupt subsistence harvest patterns for one or more seasons and disrupt some formal institutions such as whaling captains' associations. Contemporary subsistence practices and harvest patterns could be severely altered and community healthcare systems severely stressed by drawing local workers away from village service jobs. Effects on community health from response and cleanup for a VLOS could be major and last for one or more subsistence seasons.

Conclusion

If offshore oil from a VLOS directly contacted migrating or resident marine mammals, seals, fish, caribou, and/or migratory waterfowl; contaminated traditional harvest areas; and persisted in subsistence harvest areas, sociocultural systems would be severely reduced and interrupted. This would most likely lead to moderate to major impacts to community health from food insecurity, poor nutritional status, increased metabolic disorders, and low cultural well-being. Social organization, cultural values, and health and social services would most likely be disrupted for one or more seasons. Impacts to community health from a VLOS are anticipated to be severe and thus major for Nuiqsut.

Impacts from VLOS response and cleanup activities to community health could be moderate to major for Nuiqsut, Kaktovik, and Utqiagvik depending on how long cleanup would take and to what extent residents of these communities participated in response and cleanup work. If VLOS cleanup activities persisted longer than one season on the North Slope and resources and manpower were substantially drawn from all three communities, effects to community health could increase to severe and thus major for Nuiqsut, Kaktovik, and Utqiagvik. Some of these impacts would most likely be beneficial to community health through increased employment and income. Overall, BOEM anticipates moderate to major effects from a VLOS on community health for Kaktovik and Utqiagvik.

Long-term recovery from a VLOS could severely disrupt community health for more than one year, resulting in major impacts in Nuiqsut. Impacts of long-term recovery to community health for

Kaktovik and Utqiagvik are anticipated to be long lasting and widespread but less than severe and thus moderate.

4.7.9.5. Effects of a VLOS on Environmental Justice Communities

For this DEIS, BOEM analyzed effects of a Very Large Oil Spill (VLOS) greater than or equal to 4.6 MMbbls at the end of 90 days after a catastrophic event such as a loss of well control. A VLOS is a low-probability event with the potential for major effects. For more discussion on the effects of a VLOS to subsistence practices and harvest patterns see Sections 4.7.9.2 and 4.7.9.1.

A VLOS starting at the proposed LDPI could threaten some important subsistence harvest areas on which EJ communities rely. Of particular importance are the offshore bowhead whaling area used by crews from Nuiqsut and the coastal lands used by Nuiqsut and Kaktovik for subsistence caribou hunting during July through August (Figure 3.2.5-1; Table 4.4.3-1).

If offshore oil from a VLOS directly contacted migrating or resident marine mammals, seals, fish, caribou, and/or migratory waterfowl; contaminated traditional harvest areas; and persisted in subsistence harvest areas, subsistence harvest patterns would be severely interrupted, particularly bowhead whale hunting. This could create severe reductions in access to traditional nearshore and offshore harvest areas lasting one or more seasons. Social organization, cultural values, and formal institutions would most likely be disrupted for one or more seasons.

Impacts to sociocultural systems and community health from a VLOS are anticipated to be major for Nuiqsut. If these impacts occurred as anticipated as a result of a VLOS, BOEM expects disproportionately high and adverse environmental, social, and health impacts to occur for Nuiqsut.

Some impacts from VLOS spill response and cleanup activities to sociocultural systems and community health could be major for Nuiqsut, Kaktovik, and Utqiagvik depending on how long cleanup would take and to what extent residents of these communities participated in response and cleanup work. If VLOS cleanup activities persisted longer than one season on the North Slope, effects to sociocultural systems and community health would most likely be major for these EJ communities. Therefore, BOEM would expect disproportionately high and adverse environmental, social, and health impacts for these EJ communities from VLOS response and cleanup.

Long-term recovery from a VLOS could cause major disruptions to sociocultural systems and community health for more than one year in Nuiqsut. Accordingly, BOEM would expect disproportionately high and adverse environmental, social, and health impacts for Nuiqsut due to long-term recovery from a VLOS.

4.7.9.6. Effects of a VLOS on Archaeological Resources

A Very Large Oil Spill (VLOS) is initiated by a hypothetical blowout from the proposed LDPI. The scenario considers a worst case analysis without mitigating factors. Thus, the VLOS in the Proposed Action Area would have an assumed volume of 4.6 MMbbls and duration of 90 days. Cleanup activities for a VLOS may involve the use of chemical substances. These substances, depending on which chemicals are actually employed, may affect archaeological sites. The full effect of the agents on archaeological sites and shipwrecks is unknown. However, some evidence exists that the use of these substances may result in the contamination of any carbon-14 samples, making the dating of sites difficult (Borrell, 2010).

A VLOS from the proposed LDPI (LI) is not expected to affect marine cultural resources because there are no reported shipwrecks in the subject area, and acoustic remote-sensing did not discover any archaeological or historic resources on the seabed. Because the OSRA assesses trajectories to the point of contact (the intertidal zone), it is not anticipated that a VLOS would result in direct effects on those archaeological and historic resources located on land. However, a VLOS could result in minor to major impacts on a large number of archaeological and historic resources during the spill response

and clean-up phase. Cleanup crews would be needed in a greater number of locations. The greatest threat to archaeological and historic resources during a VLOS would result from the larger number of response crews being employed. Following the *Exxon Valdez* Oil Spill, most impacts to archaeological and historic resources during spill responses were the result of vandalism or physical damage from spill response activities (Bittner, 1996; Reger et al., 2000). A VLOS could result in large impacts to numerous archaeological and historic resources from spill response and clean-up activities. Given the number of resources to be considered and personnel limitations, timely monitoring of affected sites may not be possible (Reger et al., 2000).

4.8. Unavoidable Adverse Effects

Below is a list of resource areas that could experience unavoidable adverse effects under all of the action alternatives. A summary of the types of impacts resulting in unavoidable adverse effects is provided for each resource:

- **Water Quality.** An increase in suspended sediments associated with construction of the LDPI, and the presence of the LDPI itself
- **Air Quality.** Ambient air pollution from pollutant emission from diesel engines associated with vessel traffic, construction activities, and operation equipment in support of the Proposed Action
- **Lower Trophic Level Organisms.** Impacts to water quality listed above would also adversely affect lower trophic level organisms
- **Fish.** Similar adverse effects as those to water quality, but with the addition of sound from vessel traffic and oil and gas activity
- **Marine and Coastal Birds.** Collisions resulting from the physical presence of vessels and aircraft, associated with the Proposed Action
- **Marine Mammals.** Disturbance resulting from the sound and physical presence of vessels, aircraft, seismic survey equipment, drilling, construction equipment, and presence of the LDPI
- **Terrestrial Mammals.** Sound from and presence of aircraft and vehicle traffic, construction activities, and pipeline/facility presence associated with onshore oil and gas activities in support of OCS development
- **Vegetation and Wetlands.** Loss or alteration of vegetation due to gravel pit development, onshore construction/support activities, and increased vehicle traffic in support of OCS development
- **Subsistence.** Adverse effects to marine and coastal birds and marine mammals could also adversely affect subsistence-harvest patterns and sharing structures
- **Sociocultural Systems.** Adverse effects to subsistence-harvest patterns, cultural perceptions of increased oil and gas activity, increased infrastructure
- **Public Health.** minor population influx increasing social stressors/tensions
- **Environmental Justice.** Similar impacts as those to public health, related to population changes and social stressors and tensions potentially increasing
- **Archaeological Resources.** Ground and seafloor disturbing activities conducted in areas not previously surveyed have the potential to adversely affect archaeological resources

A VLOS is not considered in this section because it is extremely unlikely and the adverse effects from one are not considered “unavoidable.”

4.9. Relationship between Local Short-Term Uses and Maintenance and Enhancement of Long-Term Productivity

The Proposed Action would entail some impacts to nearly all resource areas. In each case, the potential for impacts to long-term productivity is solely derived from the risk of a large-scale oil spill. The one exception to this trend was archaeological resources: destruction of archaeological sites and unauthorized removal of artifacts could occur via development and production activities, and represent an inherently long-term loss. The potential for such impacts exists under each action alternative.

4.10. Irreversible and Irrecoverable Commitment of Resources

Irreversible and irretrievable commitment of resources refers to impacts or losses to resources that cannot be reversed or recovered. Examples include permanent conversion of wetlands or loss of cultural resources, soils, and wildlife, or changes in socioeconomic conditions.

Irreversible is a term that describes the permanent loss of future options. It applies primarily to the effects of use of nonrenewable resources, such as minerals or cultural resources, or to those factors, such as soil productivity, that are renewable only over long periods of time. Irrecoverable is a term that applies to the loss of production, harvest, or use of natural resources. For example, wetland habitat in an area is lost irretrievably while the area is being used as a gravel mine, but the action is not irreversible. Once the area is no longer needed as a gravel mine and is revegetated and restored, the wetland habitat could again become productive.

The Proposed Action would result in irreversible and irretrievable commitment of construction materials and the consumption of fossil fuels. The labor of local workers during construction would also be irretrievable, but reversible at the conclusion of that phase. Removal of habitat for fish, birds, and wildlife during construction and operation would result in irretrievable impacts to several species as well as to subsistence activities and sociocultural systems, but some of these impacts are reversible once these activities conclude. Destruction of certain cultural resources as a result of the Proposed Action could be also be considered irretrievable and irreversible.

This page intentionally left blank

Cumulative Effects

This page intentionally left blank

Table of Contents

Chapter 5. Cumulative Effects	5-1
5.1. Introduction.....	5-1
5.1.1. Framing the Analysis.....	5-1
5.1.2. Past, Present, and Reasonably Foreseeable Future Actions.....	5-2
5.1.3. Climate Change.....	5-15
5.2. Analysis of Cumulative Effects	5-15
5.2.1. Water Quality.....	5-15
5.2.2. Air Quality	5-18
5.2.3. Lower Trophic Organisms	5-21
5.2.4. Fish	5-23
5.2.5. Birds.....	5-25
5.2.6. Marine Mammals.....	5-28
5.2.7. Terrestrial Mammals.....	5-40
5.2.8. Vegetation and Wetlands	5-47
5.2.9. Sociocultural Systems.....	5-49
5.2.10. Economy	5-50
5.2.11. Subsistence-Harvest Patterns	5-54
5.2.12. Community Health.....	5-58
5.2.13. Environmental Justice.....	5-59
5.2.14. Archaeological Resources.....	5-61

List of Tables

Table 5.1.2-1. Relevant Past, Present and Reasonably Foreseeable Future Action Categories.....	5-2
Table 5.1.2-2. Past and Present U.S. Arctic Oil and Gas Discoveries as of September 2016.	5-4
Table 5.1.2-3. Past, Present, and Reasonably Foreseeable Community Development Projects.....	5-9
Table 5.1.2-4. Past, Present, and Reasonably Foreseeable Future Recreation and Tourism.	5-9
Table 5.1.2-5. Past, Present and Reasonably Foreseeable Future Marine Vessel Traffic.....	5-10
Table 5.1.2-6. Past, Present and Reasonably Foreseeable Air Traffic.....	5-11
Table 5.1.2-7. Past, Present, and Reasonably Foreseeable Future Subsistence Activities.	5-12
Table 5.1.2-8. U.S. Past, Present, and Reasonably Foreseeable Future Scientific Research.....	5-12
Table 5.1.2-9. Canadian Past, Present, and Reasonably Foreseeable Future Scientific Research..	5-13
Table 5.1.2-10. Past, Present, and Reasonably Foreseeable Future Mining Activities.	5-14
Table 5.1.2-11. Past, Present, and Reasonably Foreseeable Military Activity.	5-14
Table 5.2.2-1. Comparison of North Slope Background Concentrations to the NAAQS.	5-19
Table 5.2.10-1. Effects of the Proposed Action on Economic Measures.	5-51
Table 5.2.11-1. Impacts to Subsistence Practices for Nuiqsut, Kaktovik, and Utqiagvik.	5-54

This page intentionally left blank

CHAPTER 5. CUMULATIVE EFFECTS

5.1. Introduction

This section analyzes the potential cumulative effects of the Proposed Action and its alternatives. Cumulative impacts are defined by Council on Environmental Quality (CEQ) regulations (40 CFR 1508.7) as:

Cumulative impact is the impact on the environment which results from the incremental impact of the action when added to other past, present, and reasonably foreseeable future actions regardless of what agency (Federal or Non-federal) or person undertakes such actions. Cumulative impacts can result from individually minor but collectively significant actions taking place over a period of time.

The ultimate goal of identifying potential cumulative effects is to provide for informed decisions that consider the total effects (direct, indirect, and cumulative) of the Proposed Action and Alternatives. The CEQ handbook, “Considering Cumulative Effects under the National Environmental Policy Act (CEQ, 1997b),” suggests considering the following basic types of effects:

- Additive – the sum total impact resulting from more than one action
- Countervailing – adverse impacts that are offset by beneficial impacts
- Synergistic – when the total impact is greater than the sum of the effects taken independently

5.1.1. Framing the Analysis

BOEM used previous analyses to guide the scope of this analysis and help identify past, present, and reasonably foreseeable future actions and their effects on the marine, coastal, and human environments, though the overall scope of the analysis in this DEIS and project area are narrower. This DEIS considers the 2017-2022 OCS Oil and Gas Leasing Proposed Program EIS, the Chukchi Sea OCS Lease Sale 193 Second Supplemental EIS, the 2015 Shell Exploration Plan Environmental Assessment (EA), BLM’s 2012 NPR-A IAP/EIS, USACE’s 2012 Point Thomson EIS and NMFS’s 2016 EIS on the Effects of Oil and Gas Activities in the Arctic Ocean.

The past, present and reasonably foreseeable future actions considered for the cumulative effects analysis in this DEIS are identified in Tables 5.1.2-1 to 5.1.2-11, and are described in the subsequent sections of this chapter. In identifying past, present, and reasonably foreseeable future actions germane to this analysis, BOEM considered:

- Past oil and gas activities - activities that resulted in existing infrastructure
- Present oil and gas activities - activities for which new facilities are under construction
- Reasonably foreseeable future oil and gas activities - activities where sufficient planning and/or initiation of appropriate permitting processes have begun that they are considered likely to proceed during the life of the Proposed Action. These include potential projects in the U.S. and Canadian waters of the Beaufort Sea
- Past, present and reasonably foreseeable future actions other than oil and gas activities

Potential cumulative impacts were considered in the context of a changing climate. A changing climate could contribute to cumulative effects through:

- Increased noise and disturbance due to increased shipping
- Increased severity of storms
- Thawing of permafrost impacting onshore infrastructure

- Increased coastal erosion
- Decreases in ice cover with the potential for resultant changes in prey-species concentrations and distribution with related changes in species distributions
- Increased ocean acidity
- Range extension of species into the Arctic
- Changes in timing and magnitude of plankton blooms
- Changes in subsistence harvest practices
- Changes in potential for community economic development and regional tourism activities

While the cumulative impacts analysis in this DEIS focuses on the Proposed Action, where the selection of an alternative would lead to notable reductions (or other changes) in the project's contributions to cumulative impacts, these instances are noted.

Under the No Action alternative, the activities described in the Liberty DPP would not occur, and would not contribute to any cumulative impacts.

Both the time period and geographic scope of this cumulative impacts analysis vary according to the resource/activity under consideration. While relevant past actions can date back to the 1940s or prior, the analysis is generally focused on more recent actions. The general future timeframe extends through, at minimum, the duration of the Proposed Action (roughly 2050).

The spatial domain considered in this cumulative analysis generally extends across much of the North Slope and the Beaufort and Chukchi Seas, as any activities taking place in these regions tend to use the same infrastructure and impact interconnected resource systems. In some cases, such as with certain species of birds or marine mammals that migrate great distances, the spatial extent of the analysis may be greater.

Projects for which no official proposal has been submitted and which are not certain to occur within the foreseeable future are considered speculative. Speculative actions are not considered reasonably foreseeable and are not analyzed as part of the cumulative impacts associated with this DEIS. The intent is to keep the cumulative analysis useful, manageable, and concentrated on meaningful potential effects. The cumulative analysis considers in greatest detail activities that are more certain to happen and that are geographically in or near the project area.

5.1.2. Past, Present, and Reasonably Foreseeable Future Actions

Potentially relevant past, present and reasonably foreseeable future actions are identified in this section. General categories of these actions are introduced and discussed in Table 5.1.2-1. These include oil and gas activities, community development, recreation and tourism, marine vessel traffic, aircraft traffic, subsistence activities, research and survey activities, mining projects, and military activities.

Table 5.1.2-1. Relevant Past, Present and Reasonably Foreseeable Future Action Categories

Table	Category	Area	Type of Action
5.1.2-2	Oil and Gas Activities	State and Federal Waters (Beaufort and Chukchi Seas); Onshore Alaska North Slope; Mackenzie Delta (CAN) and Beaufort Sea; Russian Chukchi Sea	Geological and Geophysical Surveys; Infrastructure Development; Gravel Mining; Construction and Maintenance; Exploration; Energy Development and Production
5.1.2-3	Community Development	North Slope Borough	Demographic/Population Change, Migration; Commercial Fishing; Infrastructure Development Projects (e.g., Capital Improvement Projects; Energy Development, Communication)
5.1.2-4	Recreation and Tourism	Beaufort and Chukchi Sea and Adjacent Near Shore Area	Wildlife viewing (e.g., Polar Bear Viewing in Kaktovik); Sport/commercial guiding and fishing; Recreational activities; Cruise ships and commercial vessels; Increased Visitors at Arctic Refuge

Table	Category	Area	Type of Action
5.1.2-5	Marine Vessel Traffic	US and Canada Beaufort Seas; U.S. and Russia Chukchi Seas; Nearshore Beaufort and Chukchi Seas; Transportation corridors to Dutch Harbor	Industry vessels, oil field support and transports; Community barge and supply vessels; Global Shipping through the Arctic; Research Vessels; Commercial Fishing Vessels
5.1.2-6	Aircraft Traffic	Beaufort and Chukchi Seas; Overland	Industry Crew Transfers; Commercial and private flights, National and International Cargo Flights; Expansion of airfields; Research flights
5.1.2-7	Subsistence Activities	Utqiagvik, Kaktovik, Nuiqsut	Subsistence harvesting (e.g., caribou), fishing (e.g., whitefish species), and gathering; Bowhead Whaling; Traveling (small marine vessels, off-road vehicles, private fixed-wing airplanes)
5.1.2-8 and 5.1.2-9	U.S. and Canadian Research and Survey Activities	Nearshore and offshore waters (Beaufort and Chukchi Seas); Onshore	Studies and Surveys: Oceanographic; Biological; Geophysical; Archaeological; Socioeconomic
5.1.2-10	Mining Projects	North Slope Borough; Northwest Arctic Borough; Nome Census Area	Resource extraction
5.1.2-11	Military/Homeland Security Activities	Coastal sites (Northwest Alaska, North Slope); Federal waters (Beaufort and Chukchi Seas)	Distant Early Warning Line Sites maintenance and demolition; Marine and air vessel presence; Onshore base/infrastructure/ personnel

5.1.2.1. Oil and Gas Activities

Past and Present Oil and Gas Activities

Onshore oil development has been the main agent of industrial change on the North Slope and throughout the Arctic OCS in the twentieth and twenty-first centuries. Oil and gas exploration activities have occurred on the North Slope since the early 1900s, and oil production started at Prudhoe Bay in 1977. Oil production has occurred for over 40 years in the region, and presently spans from Alpine in the west to Point Thomson in the east. Onshore gas production from the Barrow gas field began over 60 years ago. Associated industrial development has included the creation of industry-supported community airfields at Deadhorse and Kuparuk, and an interconnected industrial infrastructure that includes roadways, pipelines, production and processing facilities, gravel mines, and docks.

In 1977, the Trans-Alaska Pipeline System (TAPS) began to transport North Slope crude oil to a year-round marine terminal in Valdez, Alaska. Today, it continues to transport the North Slope's entire onshore and offshore oil production, and it is projected to do so for years into the future.

Past and present on and offshore oil and gas facilities in the U.S. Arctic are summarized in Table 5.1.2-2. Oil and Gas projects in current development with future production goals are summarized in Table 5.1.2-2.

Definitions:

- Field—an area consisting of a single reservoir or multiple reservoirs all grouped on, or related to, the same general geologic structural feature and/or stratigraphic trapping condition. Fields are currently or should soon be producing hydrocarbons.
- Satellite—a small prospect or field which must use infrastructure from another field in order to be economic
- Pool—a discovered or undiscovered accumulation of hydrocarbons, typically within a single stratigraphic setting
- Prospect—a geologic feature having the potential for trapping and accumulating hydrocarbons
- Show—a one-well discovery with poorly defined limits and production capacity

Endicott Island, built in 1987, was the first continuously producing offshore oil field in the Arctic. The Northstar offshore island for oil production was constructed in 1999-2000. Northstar, as well as the Nikaitchuq and Oooguruk developments, currently operates in nearshore areas of the Beaufort

Sea, and is expected to continue operating in the future. Additional oil and gas activities that have occurred in the Beaufort Sea and Chukchi Sea OCS to date include exploration wells, exploration seismic surveys, geohazard surveys, geotechnical sampling programs, and baseline biological studies and surveys.

Table 5.1.2-2. Past and Present U.S. Arctic Oil and Gas Discoveries as of September 2016.

Production Facility Name	Production	Location	Discovery	Category
South Barrow	Gas	Onshore	1949	Field
Prudhoe Bay	Oil	Onshore	1977	Field
Kuparuk River	Oil	Onshore	1969	Field
East Barrow	Gas	Onshore	1974	Field
Lisburne	Oil	Onshore	1969	Field
Milne Point/ Kuparuk River	Oil	Onshore	1969	Field
Endicott	Oil	Offshore	1978	Field
Sag Delta North/Ivishak	Oil	Offshore	1982	Satellite ¹
Schrader Bluff	Oil	Onshore	1969	Satellite ³
Walakpa	Gas	Onshore	1980	Field
Point McIntyre	Oil	Onshore	1988	Field
Niakuk	Oil	Onshore	1985	Field
Sag River	Oil	Onshore	1965	Satellite ³
Cascade	Oil	Onshore	1993	Field
West Sak	Oil	Onshore	1971	Satellite ²
Badami	Oil	Onshore	1990	Field
Tarn	Oil	Onshore	1991	Field
Tabasco	Oil	Onshore	1986	Satellite ²
Midnight Sun	Oil	Onshore	1997	Satellite ⁴
Aurora	Oil	Onshore	1969	Satellite ⁴
Alpine	Oil	Onshore	1994	Field
Polaris	Oil	Onshore	1969	Satellite ⁴
Northstar	Oil	Offshore	1984	Field
NW Eileen/Borealis	Oil	Onshore	1969	Field
Meltwater	Oil	Onshore	2000	Field
Orion	Oil	Onshore	1968	Satellite
Palm	Oil	Onshore	2001	Field
Fiord (CD 3)	Oil	Onshore	1992	Field
Nanuq (CD 4)	Oil	Onshore	2000	Field
Qannik	Oil	Onshore	2006	Field
Raven	Oil	Onshore	2001	Field
Nuiqsut	Oil	Offshore	1992	Field
Oooguruk-Kuparuk	Oil	Offshore	1992	Field
Torok	Oil	Offshore	1992	Field
Hooligan	Oil	Offshore	1984	Field
Nikaitchuq-Schrader Bluff	Oil	Both	2004	Field
Alpine West (CD 5)	Oil	Onshore	1998	Field
Point Thomson	Gas and Oil	Onshore	1977	Field

Note: Footnotes for Satellites identify the associated production unit:

Sources: Field information from State of Alaska, Dept. of Natural Resources Division of Oil and Gas Website and Petroleum News

¹Duck Island Unit

²Kuparuk River Unit

³Milne Point Unit

⁴Prudhoe Bay Unit

Recent exploration drilling has occurred in both the Beaufort and Chukchi Sea OCS, as well as in the nearshore state waters of Smith Bay in the Beaufort Sea. In 2012, Shell Offshore, Inc. proposed exploration of two new prospects in Camden Bay, the Sivulliq and Torpedo prospects. Though four wells were permitted, only one well was drilled. The well targeted the Sivulliq prospect

approximately 16 miles offshore. Prior to penetrating potentially oil-bearing zones, Shell ceased drilling, and the well was temporarily abandoned and the exploration program was terminated.

In 2012, Shell Gulf of Mexico, Inc. also attempted exploration of the Burger prospect approximately 60 miles from shore in the Chukchi Sea OCS. As with the Sivulliq well, Shell ceased drilling, temporarily abandoned the well, and terminated the exploration program prior to penetrating the potentially oil-bearing Burger prospect. Shell returned to the Burger prospect in 2015 to drill a new exploration well, this time reaching the Burger prospect and confirming a lack of economically producible oil. The well was plugged and abandoned and Shell later relinquished all Chukchi Sea OCS leases. After relinquishments by other Chukchi Sea OCS lessees, there are currently no remaining Chukchi Sea leases issued in Lease Sale 193.

In 2016, Caelus Energy Alaska, LLC (Caelus) drilled two exploration wells into the Tulimaniq prospect on nearshore State of Alaska leases in Smith Bay approximately 59 miles southeast of Utqiagvik in the Beaufort Sea. By October 2016, Caelus announced it has made an oil discovery estimated at 200,000 barrels per day of light, highly mobile oil. The recovery rates, if correct, would put the field's estimated oil potential between 1.8 billion barrels and 4 billion barrels. By way of comparison, Prudhoe Bay oil field was originally estimated to have 25 billion barrels. Additional well testing would tell more about potential production rates.

The Alaska LNG Pipeline Project (AK LNG) has been a possibility since oil was discovered at Prudhoe Bay in the late 1960's, though the economics have not been satisfactory and the three major producers have opted to reinject the natural gas in order to increase liquid oil production. In December 2015, however, the Alaska Gasline Development Corporation approved a budget of more than \$230 million to continue preliminary engineering on the \$45-\$65 billion project.

Several recent ancillary activities have also been conducted in the Beaufort Sea OCS. BP Exploration Alaska, Inc. (BPXA) completed a 3D Ocean Bottom Node (OBN) Seismic Survey in the North Prudhoe Bay area during the open-water season of 2014. Earlier that year, SAExploration, Inc. also completed an on-ice 3-D Seismic Survey extending from onshore Alaska across nearshore State waters into the Beaufort Sea OCS. In 2012, Ion Geophysical Corporation completed a 2-D Seismic Survey across a large swath of the Beaufort Sea OCS and extending into the Chukchi Sea OCS. Other less recent Beaufort Sea OCS surveys include one 3-D survey each by Shell and BPXA in 2008 and three surveys by Shell in 2007 (one 3-D marine seismic, one 3-D on-ice seismic, and one high resolution shallow seismic survey.) Geological and Geophysical activities do not require leases and are individually permitted by BOEM after project-specific regulatory and NEPA reviews.

Reasonably Foreseeable Future Oil and Gas Activities

BOEM considered reasonably foreseeable future oil and gas activities both offshore and onshore in this cumulative effects analysis. Some activities are currently being implemented and others have been sufficiently advanced to be considered likely (e.g., are currently undergoing permitting; have been permitted, but not constructed; or have been funded for construction).

The discussion on reasonably foreseeable future actions does not include small discoveries and undiscovered resources that are very unlikely to be developed in the next 20 years. With respect to undiscovered resources, it is not reasonable to estimate new infrastructure or predict the impacts of development for prospects that have not been located or leased to industry for exploration. Accurate predictions of the location, size, or development schedules are not possible at this time, thus analyzing such development is not within the scope of this DEIS.

The following projects represent a subset of the reasonably foreseeable future onshore oil and gas activities on the North Slope of Alaska.

Point Thomson

ExxonMobil has completed the initial phase of developing this field on the eastern North Slope. Point Thomson is a gas condensate field that is currently producing condensate and shipping it via 22-mile oil pipeline to Pump Station 1 on the TAPS. Current estimated recoverable condensate resources are 200 million bbl. First oil production from Point Thomson began in May 2016. Peak production from the first stage of development at this facility is estimated at 10,000 Barrels per Day (bpd). The drillsite and production facilities are located on state onshore lands just west of the Alaska National Wildlife Refuge with long-reach wellbores drilled more than 1.5 miles into the nearshore waters of the Beaufort Sea. The project includes production pads, process facilities, an infield road system, a pipeline, infield gathering lines, and an airstrip. To avoid offshore development and potential impacts on the marine environment, onshore drilling pads were selected to enable directional drilling to offshore locations.

Greater Prudhoe Bay/Kuparuk/State Offshore Areas

This main producing part of the Alaska North Slope is expected to have numerous small developments as smaller accumulations of oil are discovered and can be produced using existing infrastructure. Production from these developments would flow from existing facilities into Pump Station 1 of TAPS. The timing of these developments would be scattered over the next 10 years.

In 2012, ConocoPhillips Alaska, Inc. (COPA) drilled a successful appraisal well into an undeveloped section of the Kuparuk formation on the southwest flank of the Kuparuk field and began construction of a new drill site in 2014. Named Drill Site 2S, this was the first new drill site in Kuparuk in 12 years. Construction was completed in 2015 and first production flowed in October 2015. Estimated peak production from this new drill site is 8,000 bpd. In 2015, COPA also dedicated funding for an extension of Kuparuk fields existing Drill Site 1H slated to begin construction in 2017 and consisting of five production wells, thirteen injection wells, and associated surface equipment. COPA anticipates first production from the 1H-NEWS extension in late 2017 at a peak rate of up to 8,000 bpd.

To the west of Kuparuk River Unit lies the Mustang oil field, part of the Southern Miluvec Unit now owned by Brooks Range Petroleum Corporation (Brooks Range Petroleum). After construction of a gravel road and drillsite and drilling several development wells starting in early 2015, Brooks Range Petroleum announced the delay of first oil production after encountering mechanical and reservoir problems while drilling. Originally anticipated in 2016, first oil production is now scheduled for late 2017 at a peak rate of 12,000 bpd. The estimated 44 million barrel Mustang field is equipped with a standalone production facility and pipeline on a gravel pad and road which connects to existing infrastructure at Kuparuk.

Alpine CD-5

COPA began construction of the newest Alpine field satellite development drill site named CD-5 in 2014. This new drill site is located on Alaska Native village corporation lands near Nuiqsut and is the first commercial oil production from within the National Petroleum Reserve in Alaska (NPR-A). As a satellite to Alpine Central Processing Facility (CPF), CD-5 has only minimal on-site processing facilities but required six miles of gravel road, four bridges, and 32 miles of pipelines including completion of a gravel road and natural gas pipeline from Alpine CPF into Nuiqsut. First production flowed from CD-5 to Alpine CPF in October 2015 and is estimated to peak at a rate of 16,000 bpd. COPA plans to continue drilling an additional 18 wells at CD-5 after the original 15 wells are completed in early 2017 for an eventual total of 33 wells.

Greater Mooses Tooth

In October 2015, COPA received approval for construction of the Greater Mooses Tooth-1 (GMT-1) project, the first commercial development on Federal lands in the NPR-A. Initially targeting the

Lookout oil pool with a total of nine wells, the GMT-1 drill site would host 24 additional wells slots for eventual development of two other oil and gas pools in the Federally-managed Greater Mooses Tooth Unit. The 7.7 mile long GMT-1 road, 2 bridges, and pipelines would connect to Alpine CPF through the existing CD-5 road and pipeline extension. Construction is expected to begin early in 2017 with anticipated first oil production late in 2018 at a peak rate of up to 30,000 bpd.

In August 2015, COPA announced submission of applications for construction of the Greater Mooses Tooth-2 (GMT-2) project on Federal lands in the NPR-A. If approved, GMT-2 would target the Spark oil pool with as many as 48 wells drilled from a 14-acre drill site 8 miles to the southwest of GMT-1. The proposed 8.6 mile gravel road and pipeline would connect through GMT-1 and on to Alpine CPF through the existing CD-5 extension. Production estimates are yet to be published but COPA anticipates first oil production by the end of 2020 if permits are approved on schedule.

Smith Bay Development

In 2016, Caelus Energy Alaska (Caelus), made a significant light oil discovery on its Smith Bay state leases on the North Slope of Alaska. Caelus estimates the amount of oil in place to be approximately 6 billion barrels with an additional 10 billion barrels of oil in place when the adjoining acreage is included. Caelus expects to achieve recovery factors in the range of 30-40% due to the favorable fluids contained in the reservoir. According to Caelus, the Smith Bay development has the potential to provide 200,000 barrels per day of light, highly mobile oil which would both increase TAPS volumes and reduce the average viscosity of oil in the pipeline, extending its long term viability. If developed, this may require constructing a new pipeline. Caelus is currently planning an appraisal program which would include drilling an additional appraisal well and acquiring a new 3D seismic survey additional acreage. The appraisal program would enable Caelus to confirm reservoir continuity, optimize future drilling locations, and ultimately increase reserves. Caelus is also studying and planning the development of facilities to process and transport the oil to TAPS.

Pikka Unit and Nanushuk Development

The Pikka Unit was approved in 2015 to accommodate Repsol and Armstrong Energy's exploration leases. Wells, referred to as Horseshoe-1 and 1A were drilled on State land during the 2016-2017 winter season in a section of the Pikka Unit known as the Nanushuk Prospect. In 2017, Repsol and Armstrong Energy reported they had discovered the largest U.S. onshore oil discovery in 30 years between the Colville River Unit, the Oooguruk Unit and the Placer Unit in the central North Slope. The Horseshoe discovery wells are located approximately 12 miles south of Nuiqsut and extend the Nanushuk Prospect by 20 miles (32 kilometers).

The Pikka Unit (including the Nanushuk Development) and the Horseshoe discovery apparently contain at least 1.2 billion barrels of recoverable light oil combined. First production for the Pikka Unit from the Nanushuk Development could occur as early as 2021, with a potential rate approaching 120,000 barrels of oil per day. Armstrong Energy, proposing to develop Nanushuk, would target oil deposits in the Alpine C and Nanushuk reservoirs. The project is southeast of the East Channel of the Colville River, located approximately 52 miles west of Deadhorse and about 6.5 miles from Nuiqsut (at the southernmost location of the Nanushuk Project). The project would include construction of the Nanushuk Pad comprised of Drill Site 1 and a Central Processing Facility, Drill Site 2, Drill Site 3, an operations center pad, infield pipelines, the export/import Nanushuk Pipeline, infield roads, and an access road.

Pipelines

BOEM also considered proposed onshore and offshore construction of pipelines for this cumulative impacts analysis.

Alaska (AK) LNG Project

The project, still in preliminary engineering and design stages and under environmental review, is a proposal originally put forth by a consortium comprised of major North Slope oil and gas producers ExxonMobil, BPXA, and COPA, along with partners TransCanada and the State of Alaska. The development would include a gas treatment plant at Prudhoe Bay to remove carbon dioxide and other impurities from the gas stream; a 42-inch-diameter, high-pressure, 800-mi (1,287 km) pipeline and eight compressor stations to move the gas to a proposed liquefaction plant at Nikiski, on the Kenai Peninsula. The Nikiski site would include LNG storage tanks and a marine shipping terminal for gas exports. Up to five take-off points for in-state gas delivery are also planned upstream of the Nikiski LNG plant.

The pipeline would be designed to accommodate 3 billion to 3.5 billion cubic feet of gas per day, with an initial mix of gas from the Prudhoe Bay and Point Thomson fields, and room to accommodate other gas fields in the decades ahead. Best case, the engineering, design and permit work could run into 2019, followed by final investment decisions, equipment procurement, construction, with first gas in 2023-2024 should the project move forward to completion.

Alaska Stand Alone Gas Pipeline

A second partnership, the Alaska Stand Alone Gas Pipeline (ASAP) project, was originally planned as a 24-in diameter natural gas pipeline with a natural gas flow rate of 500 million ft³ per day at peak capacity of consumer grade, “lean gas.” This is to be a reliable, affordable energy source to Alaskan communities. The Alaska Gasline Development Corporation in partnership with TransCanada Corp. has led the planning effort for ASAP. Production from this pipeline would emphasize in-State distribution, although surplus gas would also likely be condensed and exported. According to the USACE, the 727-mile, low pressure ASAP pipeline route would generally parallel the TAPS and Dalton Highway corridor to near Livengood, northwest of Fairbanks. At Livengood, the mainline route would continue south, to the west of Fairbanks and Nenana. The pipeline would bypass Denali National Park and Preserve to the east and would then generally parallel the Parks Highway corridor to Willow, continuing south to its connection into ENSTAR's distribution system at MP 39 of the Beluga Pipeline southwest of Big Lake. The Fairbanks 30-mile Lateral tie-in would be located approximately 2.5 miles south of the Chatanika River crossing at MP 440 of the mainline. From the mainline tie-in point, the Fairbanks Lateral pipeline would traverse east over Murphy Dome, following the Murphy Dome and Old Murphy Dome Roads, and then extend southeast into Fairbanks.

In 2015, members of The Alaska Gasline Development Corporation (AGDC) decided to put ASAP on hold, instead focusing their efforts on the AK LNG project. According to the AGDC, ASAP is the State of Alaska’s backup plan and they continue to maintain its viability and readiness in the event the Alaska LNG initiative does not progress to project sanctioning. As of 2015, the State of Alaska had already invested over 125 million dollars into ASAP.

If either project moves forward, it would include an underground pipeline with elevated bridge stream crossings, compressor stations, possible fault crossings, pigging facilities, and off-take valve locations. Either pipeline would be designed to transport a highly conditioned natural gas product, and would follow the same general route. A gas conditioning facility would need to be constructed near Prudhoe Bay and would likely require one or more large equipment modules to be off-loaded at the West Dock loading facility. Shipments to West Dock would likely require improvements to the dock facilities and dredging would be needed to deepen the navigational channel to the dockhead.

5.1.2.2. Community Development

Community development projects in Arctic communities involve both large and small infrastructure projects. Examples of community development activities are provided in Table 5.1.2-3. Examples of

past major community development projects include the construction of a new airport in Kaktovik. Smaller projects resulting from and leading to community growth could further increase demand for public services and infrastructure, such as housing, energy efficiency, water, waste disposal and storage, electricity, health care, telecommunications, port and dock construction, and roads (NSB, 2014, 2015). These infrastructure projects would likely generate increases in economic activity, and would also result in increased construction noise and air emissions, increased water turbidity and sedimentation, additional marine and aircraft traffic from construction activities, and changes in population demographics. Marine and air transportation would contribute to potential cumulative effects through noise and atmospheric pollution resulting in disturbance of marine mammals and impacts to subsistence harvest practices and related social organization and cultural values.

Table 5.1.2-3. Past, Present, and Reasonably Foreseeable Community Development Projects.

Community	Action / Project	Past	Present	Future
Kaktovik	Marine and air, airport construction upgrades, transportation, energy efficiency improvements; alternative energy infrastructure	Yes	Yes	Yes
Nuiqsut	Marine and air traffic, upgrade and expand airport facilities; capital improvement projects; improved utilities, housing, and roads; construct access road to Colville River; erosion control and new ice cellar projects	Yes	Yes	Yes
Utqiagvik	Marine and air traffic, capital improvement projects, transportation, energy efficiency improvements; alternative energy infrastructure	Yes	Yes	Yes

5.1.2.3. Recreation and Tourism

The shallow waters and industrial activity and development in the vicinity of the Proposed LDPI preclude visitations by cruise ships and make private access to the area difficult. Thus, neither recreation nor tourism is expected to occur in appreciable levels in the immediate vicinity of the Proposed Action. Recreation and tourism activities have, however, historically occurred in northern Alaska and are expected to continue and possibly increase during the 25-year life of the Proposed Action. Therefore, these activities are considered as a minor factor in this analysis. Examples of reasonably foreseeable future recreation and tourism activities are provided in Table 5.1.2-4.

Table 5.1.2-4. Past, Present, and Reasonably Foreseeable Future Recreation and Tourism.

Activity Type	Area	Action / Project	Activities	Open Water	Winter	Past	Present	Future
Wildlife Watching, Flightseeing, Cruise Ships, Wilderness Adventure	Eastern Beaufort Sea Coastal and activities originating from inland areas	River trips, wildlife viewing, hiking, flightseeing	Aircraft and, freshwater vessels	Yes	No	Yes	Yes	Yes
Wildlife Watching, Flightseeing, Cruise Ships	Eastern Beaufort Sea Coastal and Inland - North Slope (Kaktovik)	Polar bear viewing	Aircraft, marine, and freshwater vessels	Yes	No	Yes	Yes	Yes
Wildlife Watching, Flightseeing, Cruise Ships	Beaufort Sea Offshore and Nearshore	Cruise ships, eco tours	Marine vessels	Yes	No	No	Yes	Yes
Sport Hunting & Fishing	Eastern Beaufort Sea Coastal and Inland - Arctic Refuge	Hunting, Fishing, flightseeing	Aircraft, marine, and freshwater vessels	Yes	Yes	Yes	Yes	Yes

5.1.2.4. Marine Vessel Traffic

Marine vessel traffic in the past has been associated with subsistence hunting, oil exploration, research, and military activities in the Chukchi and Beaufort Seas. Weather and ice have typically limited marine vessel traffic in these areas to July through September. Future marine traffic patterns may change due to the influence of a longer ice-free period and overall decreased ice cover, potentially increasing the number of vessels associated with industrial transportation, tourism, and non-subsistence fishing. The USCG recently completed a Port Access Route Study to increase the efficiency of vessel traffic in the Chukchi Sea, Bering Strait and Bering Sea. Most vessels engaged in OCS activity in the Beaufort and Chukchi Seas would follow these shipping lanes as they transit

through the Bering Strait, unless environmental conditions such as heavy ice cover make following those routes impracticable. Transits of the Northern Sea Route, used by vessels carrying oil and gas products from Russian oilfields to the far east, are usually draft limited to 12 or 13 meters, which limits the maximum size of these vessels. Table 5.1.2.5 below summarizes the major sources of marine vessel traffic in the Proposed Action Area of effect.

Dutch Harbor, Alaska, is an extremely busy commercial port and thousands of vessels pass through the area annually. While BOEM does not regulate transit from Dutch Harbor, most vessels used for the Liberty Project would transit from Dutch Harbor to the Project Area for resupply each drilling season.

Table 5.1.2-5. Past, Present and Reasonably Foreseeable Future Marine Vessel Traffic.

Area	Project	Activities	Open Water	Winter	Past	Present	Future
Coastal	Supply Barges	Marine and freshwater vessels	Yes	No	Yes	Yes	Yes
Coastal	Native boat traffic	Subsistence, travel, small boats	Yes	No	Yes	Yes	Yes
Coastal	Industry crew change, supply and materials transfer	Hydrocarbon offloading, transport, storage, marine vessel traffic	Yes	No	Yes	Yes	Yes
Coastal	Donlin Gold Mine	Marine vessel traffic	Yes	No	No	No	Yes
Offshore	Icebreaker and ice management, Northern Sea Route tanker transport of crude oil Marine Vessel Traffic	Marine vessel traffic	Yes	Yes	Yes	Yes	Yes
Offshore	Crew transfer, transport of supplies and equipment, aircraft traffic	Marine vessel and aircraft traffic	Yes	Yes	Yes	Yes	Yes

Marine vessels are the greatest contributors of anthropogenic sound introduced to the Beaufort Sea. Sound levels and frequency characteristics of vessel sound are generally related to vessel size and speed. Larger vessels generally emit more sound than do smaller vessels. Same size class vessels travelling at higher rates of speed generally emit more sound than the same vessels travelling at lesser speeds. Vessels underway with a full load, or vessels pushing or towing loaded non-powered vessels, generate more sound than unladen vessels in a similar size class. The most common sources of marine vessel noise are propulsion engines, generators, bearings, pumps, and other similar components. Operations and navigation equipment, including fathometers and sonar equipment, also contain mechanical components that create and propagate sound into the marine environment. The most intense level of sound pressure introduced into the water from an underway marine vessel originates from cavitation associated with the energy of spinning propellers. Moored vessels can generate sound from the operation of engines and pumps. Cranes or other equipment performing construction activities or other work functions may transmit sound directly to the marine environment through the air-water interface or through propagation of sound waves through hulls or other support structures.

The number of marine vessels in both the Beaufort and Chukchi Seas has increased in recent years due to advances in the technology of ice strengthening and ice breaking capacities, changes in ice cover and classifications of ice, increases in use of both the Northern Sea Route over Russia and the Northwest Passage through Canada for commercial and tourist voyages, and increased interest in scientific and economic pursuits in the area. Reasonably foreseeable future traffic in the region includes small craft involved in the fall whaling hunt at Utqiagvik and Wainwright; USCG vessels; cargo vessels; other supply ships, tugs, and barges; cruise ships; and vessels associated with scientific endeavors. There are also several newly built ice strengthened LNG carriers and more on order that are expected to carry an increasing volume of Russian LNG Cargoes across the Northern Sea Route and through the Bering Strait to markets in the far east. As more development takes place on the North Slope and in other coastal areas in Western Alaska (e.g., Donlin Mine) vessel traffic in Dutch Harbor may increase.

USCG District 17 (USCG, 2013) reported annual vessel traffic transiting the Bering Strait, which is the entry and exit point to the Western Arctic, increased from 220 to 480 vessels a year (a more than 100% increase) between 2008 and 2012. In recent years, there has been a drop in Bering Strait

transits. There were 440 in 2013 and 340 in 2014. The Office of Naval Intelligence (2014) reported Bering Strait transits may exceed 1,000 vessels per year by 2025 due to changes in ice patterns across the northern sea routes ($\geq 400\%$ increase from 2012 numbers). The same publication reports that in 2012, 96 vessel passages occurred in the Northern Sea Route over Russia and the Northwest Passage through Canada combined. That level of activity may increase to 1,000 passages by 2025, due to an increase in open water periods from approximately two to more than five weeks, resulting in cost savings because of shorter routes and transit times. The estimated number of miles of non-seismic vessel traffic in the Chukchi Sea for July through October increased from approximately 2,000 miles in 2006 to more than 11,500 miles in 2010 (Marine Exchange of Alaska, 2011). Vessel tracks from 2009 indicate vessel transits in the vicinity of Utqiagvik and Wainwright are traditionally concentrated along the coast (Marine Exchange of Alaska, 2011).

5.1.2.5. Aircraft Traffic

Air traffic has increased in recent years, mostly from increases in research, survey, commercial, military, and recreational operations. Table 5.1.2-6 summarizes past, present, and reasonably foreseeable air traffic in the Beaufort and Chukchi Seas. Aircraft traffic in the Arctic includes fixed wing and helicopter flights for research programs and marine mammal monitoring operations; cargo flights for supplies to villages and for commercial ventures including oil and gas related activities (such as crew changes and supply flights); flights for regional and inter-village transport of passengers; air-ambulance and search and rescue emergency flights; general aviation for the purpose of sport hunting and fishing or flightseeing activities; and multi-governmental military flights. An average of 92 U.S. carrier flights per month occurred from Nuiqsut airport and 291 U.S. carrier flights per month occurred from Utqiagvik's Wiley Post-Will Rogers Memorial Airport between July and October, 2003 to 2016 (http://www.transtats.bts.gov/Data_Elements.aspx?Data=2). Nationally, the Federal Aviation Administration forecasts an average annual increase in aircraft operations of 2.0% for air carriers, 1.5% for air taxis with commuters, and 0.3% for total general aviation through 2032 (FAA, 2012, Table 32).

Table 5.1.2-6. Past, Present and Reasonably Foreseeable Air Traffic.

Area	Project	Traffic Type	Open Water	Winter	Past	Present	Future
Coastal	Aerial surveys of marine mammals	Air traffic	Yes	Yes	Yes	Yes	Yes
Coastal	Scheduled air transportation	Air traffic	Yes	Yes	Yes	Yes	Yes
Coastal	Coastline erosion surveys	Air traffic	Yes	No	Yes	Yes	Yes
Coastal	Tourism	Flightseeing	Yes	Yes	Yes	Yes	Yes
Offshore	Industry crew changes and supply flights	Helicopter traffic	Yes	Yes	Yes	Yes	Yes
Offshore	Marine mammal surveys	Air traffic	Yes	Yes	Yes	Yes	Yes

Note: Area includes Beaufort and Chukchi Seas.

5.1.2.6. Subsistence Activities

Two major subsistence resource categories occur on the North Slope: coastal/marine and terrestrial/aquatic (Table 5.1.2-7). Coastal/marine food resources include whales, seals, walrus, waterfowl, and fish. Terrestrial/aquatic resources include caribou, freshwater fish, moose, Dall sheep, edible roots and berries, and furbearing animals. Generally, communities harvest resources most available to them. The distribution, migration, seasonal, and more extended cyclical variation of animal populations drive decisions on what, where, and when to harvest a subsistence resource. Many areas might be used infrequently, but they can be quite important harvest areas when they are used. Subsistence activities tend to be concentrated along rivers, lakes, and coastlines, near communities, and where resources are at high abundance levels.

Table 5.1.2-7. Past, Present, and Reasonably Foreseeable Future Subsistence Activities.

Action / Project	Community	Open Water	Winter	Past	Present	Future
Bowhead whale harvest	Kaktovik, Nuiqsut, Utqiagvik	Small boat and snowmachine travel	Yes	Yes	Yes	Yes
Harvest of beluga, walrus, seals	Kaktovik, Nuiqsut, Utqiagvik	Small boat and snowmachine travel	Yes	Yes	Yes	Yes
Hunting, gathering, fishing, trapping, and associated activities.	Kaktovik, Nuiqsut, Utqiagvik	Small boat, vehicular, and snowmachine travel	Yes	Yes	Yes	Yes

The subsistence pursuit of bowhead whales has major importance to the communities of Utqiagvik, Nuiqsut, and Kaktovik. The harvesting, processing, distribution, and sharing of whale *muktuk* and whale meat is important and continues to be the most valued activity in the subsistence economy of these communities. It is anticipated that subsistence activities would continue in the foreseeable future.

5.1.2.7. Scientific Research Activities

Numerous offshore scientific research programs in the Beaufort and Chukchi Seas are conducted annually (Table 5.1.2-8). These activities involve vessel, air, and over-ice support which may contribute to cumulative effects through disturbance of marine animals and impacts to subsistence harvest through marine vessel and aircraft traffic, and disturbance of bottom sediments through sampling for biological and chemical studies.

Table 5.1.2-8. U.S. Past, Present, and Reasonably Foreseeable Future Scientific Research.

Project	Activities	Open Water	Winter	Past	Present	Future
Arctic Nearshore Impact Monitoring in Development Area (ANIMIDA III)	Long term environmental monitoring, including boulder patch kelp beds, sediment and water column contaminants, bioaccumulation, marine vessel traffic	Yes	No	Yes	Yes	Yes
Bowhead whale satellite tagging study (ADF&G)	Satellite telemetry of bowhead whales, ecology, diving behavior, feeding behavior, marine vessel traffic	Yes	No	Yes	Yes	Yes
Bowhead Whale Aerial Survey Project (BWASP), COMIDA, and Aerial Surveys of Arctic Marine Mammals (ASAMM)	Aerial surveys of the autumn migration of bowhead whales through the Alaskan Beaufort Sea and transect data on all other marine mammals sighted. Aerial traffic	Yes	No	Yes	Yes	Yes
Distributed Biological Observatory (IARPC)	Long term monitoring of active biological zones in the Chukchi and Beaufort Seas, collections of physical and biological data, marine vessel traffic	Yes	No	Yes	Yes	Yes
U.S. Canada Transboundary Fish and Lower Trophic Communities	Regional area survey of fish and benthic invertebrates, physical oceanography marine vessel traffic	Yes	No	Yes	Yes	Yes
ShoreZone: Mapping of the North Slope of Alaska	Helicopter flights of coastline, filming of coastal loss and erosion, collecting and mapping coastal vegetation zones aerial traffic	Yes	No	Yes	Yes	No
Shorebirds and Infaunal Abundance and Distribution on Delta Mudflats along the Beaufort Sea	Benthic invertebrate collections, bird observations, sediment collections	Yes	No	Yes	Yes	Yes
Ice seal movements and foraging: Village based satellite tracking of ringed and bearded seals	Satellite telemetry studies of ice seals, traditional knowledge component through interviews of village elders small boat traffic, local	Yes	No	Yes	Yes	Yes
Chukchi Sea Environmental Sciences Program (CESP)	Physical and chemical oceanography, acoustic moorings, biological sampling of plankton, invertebrates, and fish. bird and mammal observational data. marine vessel traffic	Yes	No	Yes	Yes	Yes
Chukchi Sea Acoustic, Oceanography and Zooplankton Study	Physical and chemical oceanography, acoustic moorings, biological sampling of plankton, invertebrates, and fish. bird and mammal observational data. marine vessel traffic	Yes	No	Yes	Yes	Yes

Project	Activities	Open Water	Winter	Past	Present	Future
Use of the Chukchi Sea by Endangered Baleen and other Whales (Western Extension of BOWFEST)	Aerial surveys of bowhead whales aerial traffic	Yes	No	Yes	Yes	Yes
COMIDA: Ecosystem Observations in the Chukchi Sea: Biophysical Mooring and Climate Modeling	Physical oceanography, benthic, zooplankton, fish, acoustic, bird, mammal, and ice studies. marine vessel traffic	Yes	No	Yes	Yes	Yes
COMIDA-CAB: Chemical and Benthos	Chemical oceanography, collection of benthic sediment and biological sampling, marine vessel traffic	Yes	No	Yes	No	No
COMIDA: Factors Affecting the Distribution and Relative Abundance of Endangered Whales: Passive Acoustic Detection and Monitoring of Endangered Whales in the Arctic	Aerial surveys of bowhead whales, physical oceanography, benthic, zooplankton, fish, acoustic, bird, mammal, and ice studies. marine vessel and aircraft traffic	Yes	No	Yes	No	No
Pinniped Movements and Foraging: Walrus Habitat Use in the Potential Drilling Areas	Satellite telemetry and tagging of walrus	Yes	No	Yes	No	No
NASA, USGS, NOAA	Physical oceanography, ice studies, marine mammals population and ecological studies, seismic and side scan radar studies, sediment coring marine vessel and air traffic	Yes	Yes	Yes	Yes	Yes
Arctic Ecosystem Integrated Survey	Development of a framework to select habitat focus areas, to improve understanding of ecological and hydrodynamic factors pertaining to impacts of oil spills.	Yes	Yes	Yes	Yes	Yes
Office of Naval Research, and other military research ventures	Various studies involving national security interests, maneuvers, etc. marine vessel and air traffic	Yes	Yes	Yes	Yes	Yes

Future scientific research on the Canadian Beaufort Sea that may reasonably be expected to impact U.S. OCS interests is summarized in Table 5.1.2-9.

Table 5.1.2-9. Canadian Past, Present, and Reasonably Foreseeable Future Scientific Research.

Project	Activities	Open Water	Winter	Past	Present	Future
U.S. Canada Transboundary Fish and Lower Trophic Communities	Regional area survey of fish and benthic invertebrates, physical oceanography marine vessel traffic	Yes	No	Yes	Yes	Yes
Oceans and Fisheries Canada (OFC) Arctic Fish Ecology and Assessment Research (AFEAR)	Oceanographic and biological sampling, marine vessel traffic	Yes	Yes	Yes	Yes	Yes
OFC Arctic Marine Mammal Ecology and Assessment Research (AMMEA)	Bowhead tagging, marine vessel traffic	Yes	Yes	Yes	Yes	Yes
Ocean Fisheries Canada Arctic Stock Assessment movement of ringed seals, belugas, fish survey	Satellite telemetry studies. aerial surveys, small vessel traffic	No	No	No	Yes	Yes
Canadian High Arctic Research Station (CHARS)	Physical, chemical, and biological research, marine mammal research, vegetation and wetlands studies, indigenous studies. marine vessel and aircraft traffic	Yes	Yes	No	Yes	Yes

It is anticipated that scientific research activities would continue into the foreseeable future at potentially greater levels, due to the increased concerns about climate change and associated effects.

5.1.2.8. Mining Projects

The majority of mining activities in Alaska take place hundreds of miles inland from the Proposed Action but are included here because marine and air transportation associated with these activities could contribute to potential cumulative effects through the disturbance of marine mammals and impacts to subsistence harvest.

The world's largest known zinc resources are located in the western Brooks Range. As much as 25 million tons of high-grade zinc is estimated to be present near Red Dog Mine, approximately 40 mi (64 km) from the southwest corner of the NPR-A (Audubon Alaska, 2002). Due to the potentially high levels of activity associated with Red Dog mine, BOEM considers it as part of the cumulative effects analysis despite its geographic distance from the Liberty project. In addition, one of the largest undeveloped gold deposits in the world is located in western Alaska. Donlin Gold Mine is located about 10 miles from Crooked Creek Village near the Kuskokwim River. This mine would use both marine and air transport. Past, present and reasonably foreseeable future activities related to mining activities are summarized in Table 5.1.2-10.

Table 5.1.2-10. Past, Present, and Reasonably Foreseeable Future Mining Activities.

Area	Action / Project	Activities	Open Water	Winter	Past	Present	Future
Southwest Chukchi Sea Inland - Red Dog Mine	Red Dog Mine	Marine vessel traffic, aircraft traffic	Yes	Yes	Yes	Yes	Yes
Southwest Alaska, Bering Sea area, Donlin Gold Mine,	Minerals Export	Marine vessel traffic, aircraft traffic	Yes	No	No	No	Yes

5.1.2.9. Military / Homeland Security Activities

Military activity in the Arctic is thought to have increased in recent years, and it is reasonable to expect military activities should increase in the foreseeable future (Axe, 2015; Watkins, 2015). Military activities in the Arctic include movements of military vessels and submarines (Vandiver, 2016), and aircraft, as well as ground operations (Olson, 2016). Military vessel, submarine, aircraft traffic, and the potential for spills could contribute to cumulative effects through the disturbance of marine mammals and effects to the subsistence harvest (Table 5.1.2-11).

Table 5.1.2-11. Past, Present, and Reasonably Foreseeable Military Activity.

Area	Action / Project	Activities	Open Water	Winter	Past	Present	Future
Eastern Beaufort Sea Coastal -Barter Island	Distant Early Warning Line Sites	Radar site still active, aircraft traffic, barge traffic	Yes	Yes	Yes	Yes	Yes
Central Beaufort Sea Coastal - Bullen Point SRRS ¹	Distant Early Warning Line Sites	Aircraft traffic, barge traffic	Yes	Yes	Yes	Yes	Yes
Central Beaufort Sea Coastal -Flaxman Island SRRS ¹	Distant Early Warning Line Sites	Demolition complete	No	No	Yes	No	No
Western Beaufort Sea Coastal -Point Barrow	Distant Early Warning Line Sites	Demolition complete but radar site still active, aircraft and barge traffic	No	No	Yes	No	No
Eastern Chukchi Sea Coastal -Wainwright	Distant Early Warning Line Sites	Potential demolition, aircraft and barge traffic	No	No	Yes	Yes	No
Central Chukchi Sea Coastal -Point Lay	Distant Early Warning Line Sites	Demolition complete	No	No	Yes	No	No
Central Chukchi Seas Coastal - Cape Lisburne	Distant Early Warning Line Sites	Radar site still active, aircraft traffic, barge traffic	No	No	Yes	Yes	Yes
Western Chukchi Sea Coastal -Kotzebue	Distant Early Warning Line Sites	Potential demolition, aircraft and barge traffic	No	No	Yes	No	No
Submarines, other Naval Vessels	Arctic Submarine Laboratory has conducted various arctic activities since 1940 ¹ .	Vessel traffic, sonar impacts, ship strikes	Yes	Yes	Yes	Yes	Yes
US Coast Guard icebreakers	POLAR STAR and HEALY icebreakers	Vessel traffic and icebreaking	Yes	Yes	Yes	Yes	Yes
US Coast Guard – Chukchi and Beaufort Seas	Arctic Operations and Training Exercises	Shore-, air-, and sea-based operations; includes increased aircraft and vessel traffic, berthing and facilities for personnel,	Yes	Yes	Yes	Yes	Yes
Overflights	North American Aerospace Defense Command (NORAD) Elmendorf AFB	Aircraft traffic	Yes	Yes	Yes	Yes	Yes

Note: ¹ <http://www.csp.navy.mil/asl/Timeline.htm> locations unknown

5.1.3. Climate Change

Climate change is an ongoing consideration in evaluating cumulative effects on environmental resources of the Arctic region (See Section 3.1.6 for more information).

Research evaluated by organizations such as the Intergovernmental Panel on Climate Change (IPCC) found that “rising global emissions of GHG are significantly affecting the earth’s climate” (CEQ, 2010; IPCC, 2013). As a result of these GHG emissions and subsequent environmental effects, Alaska has warmed more than twice as rapidly as the rest of the United States, with state-wide average annual air temperature increasing by 3°F (1.7°C) and average winter temperature by 6°F (3.3°C) over the past 60 years (Stewart et al., 2014). Average annual temperatures in Alaska are projected to rise by an additional 2°F to 4°F (1.1-2.2°C) by 2050. If global emissions continue to increase during this century, temperatures can be expected to rise 10°F to 12°F (5.6-6.7°C) in the north, 8°F to 10°F (4.4-5.6°C) in the interior, and 6°F to 8°F (3.3-4.4°C) in the rest of the state. Even with substantial emissions reductions, Alaska is projected to warm by 6°F to 8°F (3.3-4.4°C) in the north and 4°F to 6°F (2.2-3.3°C) in the rest of the state by the end of the century (Markon, Trainor, and Chapman, 2012).

Due to these influences, climate change is an ongoing factor in the consideration of cumulative impacts in the Arctic region. Climate change has been implicated in changing weather patterns, changes in the classification and seasonality of ice cover, ocean surface temperature regimes, and the timing and duration of phytoplankton blooms in the Arctic (NMFS, 2013c). These changes have been attributed to rising CO₂ levels in the atmosphere and corresponding increases in the CO₂ levels of the waters of the world’s oceans, which have led to the phenomena of ocean acidification (IPCC, 2007a; Mathis et al., 2014). This phenomena is often called a sister problem to climate change because they are both attributed to human activities that have resulted in increased CO₂ levels in the atmosphere. Ocean acidification in high latitude seas is happening at a more advanced rate compared to other areas of the ocean. The capacity of the Arctic Ocean to uptake CO₂ should increase in response to predicted increase in atmospheric CO₂ levels (Bates and Mathis, 2009). Sea ice losses increase the open water surface area of Arctic seas, and exposed surface water lowers calcium carbonate solubility, or saturation, leading to lower levels of available minerals for shell-producing organisms (Fabry et al., 2009). In addition, climate change could affect the natural cycles occurring in the Arctic. Many of the organisms present in the Arctic during the summer breeding season are migratory. The regions used during other life stages of their annual cycle may not be experiencing climate change at the same rate as in the Arctic. This could lead to phenological mismatches of organisms with their habitats or prey species where time-sensitive relationships, such as breeding, could be changed to the detriment or benefit of some species (Miller-Rushing et al. 2010).

Measurable changes in climate are ongoing and have been occurring over the last 180 years in Alaska (Smith et al., 2005; Wendler and Shulski, 2009; Abram et al., 2016) and are projected to occur into the future (Markon, Trainor, and Chapman, 2012). See Chapters 3 and 4 of this DEIS for further discussion of climate change.

5.2. Analysis of Cumulative Effects

5.2.1. Water Quality

5.2.1.1. Summary of Impacts

Impacts on water quality from the Proposed Action and alternatives are analyzed in detail in Chapter 4 and summarized here. Effects on water resources include:

- Introduction of pollutants
- Increased suspended sediments

- Increased turbidity
- Temporary disruption of flow, decreased water levels, and physical alteration of ponds, lakes, and streams
- Introduction of invasive species
- Accidental oil spills

The primary impact to water quality as a result of the Proposed Action is increased TSS. Adverse impacts to water quality would be moderate for short periods of time, but negligible overall.

5.2.1.2. Discussion of Other Relevant Actions

Other relevant actions that have occurred in the past, are currently occurring, or may occur in the foreseeable future that affect or could affect water resources in the U.S. Beaufort Sea and fresh or estuarine waters in the surrounding lands are described in Tables 5.1.2-1 through 5.1.2-11. These actions could originate in the U.S. Arctic, Canadian Arctic, or the Russian Arctic.

Activities described in Tables 5.2.1-1 through 5.1.2-11 that occur in or near waterbodies can affect water quality through a variety of ways, including: discharges of pollutants; increases in suspended sediments and turbidity; decreases in dissolved oxygen in bottom water; increased risk of introducing aquatic invasive species; increased risk of hydrocarbon spills; and elevated sea surface temperatures and salinity levels.

5.2.1.3. Analysis of Cumulative Impacts

Impacts on water quality of the activities described in Tables 5.1.2-1 – 5.1.2-11 would depend on the number of sources, their location, and their duration.

The Proposed Action would temporarily increase vessel traffic on a localized level. This increase in vessel traffic would be additive to increasing vessel traffic from global shipping vessels, oil and gas vessels, cargo vessels, military vessels, supply barges, cruise ships, commercial fishing vessels, survey vessels, and research vessels.

Discharges from many types of vessels are regulated by the EPA and the U.S Coast Guard. EPA's Vessel General Permit (VGP) applies to discharges from the normal operation of all non-recreational, non-military vessels 79 feet long or more, which discharge to waters of the United States (defined at 40 CFR 122.2) extending to the outer reach of the three-mile territorial sea (see 40 CFR 122.2 and CWA Section 502(8)). The VGP ballast water discharge provisions also apply to any non-recreational vessel less than 79 feet long or commercial fishing vessel of any size. Information on the VGP is online at: <http://cfpub.epa.gov/npdes/vessels/vgpermit.cfm>.

Section 312 of the CWA sets out the principal framework for domestically regulating sewage discharges from vessels, and is implemented jointly by the EPA and the U.S. Coast Guard. The CWA defines sewage as "human body wastes and the waste from toilets and other receptacles intended to receive or retain body wastes," and includes gray water discharges from commercial vessels (see 33 USC 1322(a)(10)). CWA Section 312 controls vessel sewage by regulating the equipment that treats or holds the sewage, called marine sanitation devices (MSDs) (see 33 USC 1322(a)(5)). Support vessels are required to use operable, U.S. Coast Guard certified MSDs onboard when operating in U.S. waters, including the three-mile territorial sea

Impacts from the Proposed Action would be additive to the existing impacts to water resources from discharges; bottom habitat disturbance and resulting suspended sediments from the construction of the LDPI; water withdrawals; point-source discharges; and small and large spills. Under the Proposed Action, an increase of TSS in the water column during the construction, maintenance and decommissioning stages of the project would be expected. Should construction, maintenance and decommissioning of other artificial gravel islands or subsea pipelines occur at the same time, the

effect of TSS would be additive to these other past, present and reasonably foreseeable future activities. It is anticipated the effects of TSS on water quality would be intermittent and localized.

Pursuant to the Clean Water Act Section 402, wastewater discharges from oil and gas exploration facilities in the Beaufort and Chukchi Seas require authorization by EPA, or if in State waters, by ADEC. Discharges into the territorial seas, the contiguous zone and the oceans may not cause an unreasonable degradation of the marine environment as determined under 40 CFR Part 125 Subpart M. On October 29, 2012, EPA issued two NPDES general permits for exploration discharges into the Beaufort and Chukchi Seas-permit numbers AKG-28-2100 and AKG-28-8100, respectively. The general permits authorize discharges from 13 categories of waste streams, subject to effluent limitations, restrictions, and requirements. The general permits require operators to submit Notices of Intent to EPA requesting authorization to discharge at least 120 days prior to commencing discharges. Information about EPA's general permits for offshore oil and gas discharges to federal waters of the Beaufort and Chukchi Seas can be found at <https://yosemite.epa.gov/r10/water.nsf/npdes+permits/arctic-gp>.

In addition, on January 29, 2015, EPA issued a final wastewater discharge general permit authorizing discharges from Oil and Gas Geotechnical Surveys and Related Activities in Federal Waters of the Beaufort and Chukchi Seas (Geotechnical General Permit; AKG-28-4300). The Geotechnical General Permit authorizes 12 types of wastewater discharges from oil and gas geotechnical surveys and related activities. The General Permit establishes effluent limitations and requirements to ensure the discharges do not cause unreasonable degradation of the marine environment. Information about EPA's Geotechnical General Permit can be found online at <https://yosemite.epa.gov/r10/water.nsf/npdes+permits/arctic-gp>.

ADEC has developed a similar permit under its APDES permitting authority for oil and gas geotechnical surveying activity discharges to state waters of the Beaufort and Chukchi Seas. The APDES general permit AKG283100 – Geotechnical Facilities in State Waters in the Arctic Ocean (the APDES Geotechnical GP) was issued on May 31, 2015. A detailed summary of the APDES Geotechnical GP is included in the Final Fact Sheet, available online at <https://dec.alaska.gov/water/wwdp/pdfs/PublicNoticedocs/AKG283100%20-%20Arctic%20Geotech%20Final%20FS%20v.final.PDF>.

The Proposed Action would increase onshore construction and maintenance projects and facilities on a short-term basis, adding incrementally to the effects from past, present, and future onshore development and mining that affect water resources (Table 5.2.1-1). The Proposed Action would also add incremental impacts to water resources from water withdrawals; non-point source discharges; gravel pad construction; permitted discharges into freshwaters; permitted discharges to nearshore waters; ice road and pad construction; and gravel mining for construction of the LDPI.

Rising CO₂ levels in the atmosphere and corresponding increases in CO₂ in the world's oceans have led to the phenomenon of ocean acidification (IPCC, 2007). The capacity of the Arctic Ocean to uptake CO₂ is expected to increase in response to climate change (Bates and Mathis, 2009). Ocean acidification in high latitude seas is happening at a more advanced rate than other areas of the world. This is due to the loss of sea ice that increases the surface area of the sea to warmer air temperatures.

Several studies have examined the effects of climate change on water resources (see Guinotte and Fabry, 2008; Mathis et al., 2014; SeaGrant Alaska, 2012). Climate change effects in the Arctic that impact marine and freshwater environments include:

- Warming sea temperatures
- Acidification of seawater (decrease in pH)
- Sea ice extent and thickness decreasing: increased sea surface exposed for accelerated warming of water; greater area for air-sea exchange of carbon dioxide; decreases in surface salinity

- Coastal erosion increasing
- Aquatic invasive species, risk of introduction
- Warming pond temperatures – changes in surface area and levels (“drying”)
- Melting permafrost – erosion of riverbanks and streambanks; changes in riparian vegetation and channel morphometry
- Snowpack melt increasing - river discharge increase, sea surface water salinity decrease

Activities associated with the Proposed Action, along with other past, present and reasonably foreseeable actions may have an additive effect on the impacts of climate change in the Beaufort Sea region.

5.2.1.4. Conclusion

Impacts of the Proposed Action on water quality are expected to be negligible because they are short-term and localized (Section 4.2.2). Activities associated with the Proposed Action, when combined with other past, present and reasonably foreseeable actions may have an additive or synergistic impact (an impact that results from the combination of two separate impacts) on climate change in the Beaufort Sea region. The overall contribution to water quality impacts from activities associated with the Proposed Action, when combined with impacts from the other past, present, and reasonably future actions described in Tables 5.1.2-1 through 5.1.2-11, would range from negligible to minor.

5.2.2. Air Quality

This analysis of cumulative effects on air quality focuses on the impacts to the onshore areas nearest the Proposed Action and the Alaska communities along the coastline adjacent to the Liberty Development Area. The qualitative analysis is based on the behavior of pollutants released during activities associated with the Proposed Action, and how the pollutants are diluted (mixing with surrounding air) and diffused (plume continually expanding throughout both the vertical and horizontal planes) by surrounding air and the wind. The duration of the effects, if any, are temporary, as pollutants are assumed to remain within the main exhaust plume only until impact with the ground – they are not additive, meaning the overall impact is less than the sum of the parts. Afterwards, the pollutants scatter and are further diluted into the surrounding air, causing ever decreasing effects as they are transported farther from the source and around the globe.

Summary of Impacts

Effects of emissions associated with the Proposed Action are caused by the discharge of diesel and fuel gas (natural gas) engine exhaust gases resulting from combusting fossil fuels and gases in mobile and stationary engines used to construct, implement, and operate aspects of the Proposed Action. Additional evaporative emissions of VOCs would occur from small spills. The dominant air pollutant throughout the Proposed Action is nitrogen oxides (NO₂). The Proposed Action would result in a minor air quality impact to the countervailing effects of wind and the dilution and diffusion of the pollutants over space and time.

Mobile sources of emissions from the Proposed Action would not produce emissions in masses sufficient to overwhelm the effects of their own movements combined with wind and transport (dilution and diffusion) over space and time. As such, accumulation of the pollutants in a single onshore location would not occur, and deterioration of air quality due to the Proposed Action emissions would not follow.

Projected emissions from stationary sources associated with the Proposed Action would be regulated under 30 CFR part 550 Subpart C. Stationary sources whose emissions would otherwise cause an exceedance of ambient air quality standards incorporated into the BOEM AQRP would be required to

apply Best Available Control Techniques (BACT) to reduce emissions so that the emissions are not deemed to significantly affect the air quality of the onshore area.

Discussion of Other Relevant Actions

The past, present, and reasonably foreseeable future actions listed in Table 5.1.2-1 each represent potential air emissions either onshore or near-shore. Most of the actions can be characterized as mobile or stationary sources. Actions that require aerial surveys using helicopters and small aircraft, transportation by motor vehicles, other over-ice types of vehicles, or use of marine vessels are mobile sources. There are many sources of emissions already existing on the North Slope. However, none produces air emissions that cause an exceedance or violation of the National Ambient Air Quality Standards (NAAQS). A summary of the EPA approved background concentrations for both the onshore areas adjacent to the Beaufort and Chukchi Sea OCS is provided in Table 5.2.2-1.

Table 5.2.2-1. Comparison of North Slope Background Concentrations to the NAAQS.

Pollutant	Averaging Period	EPA-Approved Background Concentrations ($\mu\text{g}/\text{m}^3$)	NAAQS ($\mu\text{g}/\text{m}^3$)	Background Percent of the NAAQS
NO ₂ Nitrogen dioxide	1-hour	81	188	43.1%
NO ₂ Nitrogen dioxide	Annual	1	100	1.0%
PM _{2.5} Fine particulate matter	24-hour	6	35	17.1%
PM _{2.5} Fine particulate matter	Annual	3	12	20.0%
PM ₁₀ Coarse particulate matter	24-hour	53	150	35.3%
SO ₂ Sulfur dioxide	1-hour	13	196	6.6%
SO ₂ Sulfur dioxide	3-hour Secondary Standard	11	1,300	0.8%
SO ₂ Sulfur dioxide	24-hour	4	365	1.1%
SO ₂ Sulfur dioxide	Annual	2	80	2.5%
CO Carbon monoxide	1-hour	1742	40,000	4.4%
CO Carbon monoxide	8-hour	1094	10,000	10.9%

Source: EPA (2011b, Table 4).

The EPA-approved background concentrations given in Table 5.2.2-1 were recorded at the Wainwright Permanent monitoring site since 2009, replacing the Wainwright Near-Term monitoring site. EPA states in their 2011 “Supplemental Statement of Basis for Proposed Outer Continental Shelf Prevention of Significant Deterioration Permits Noble Discoverer Drillship,” that the information in Table 5.2.2-1 above summarizes, “the background concentrations that Region 10 is relying upon for the air quality analyses for the 2011 Revised Draft Permits” (EPA, 2011b).

5.2.2.1. Analysis of Cumulative Impacts

Actions described in Table 5.1.2-2 did not occur simultaneously with activities associated with the Proposed Action. Emissions from those past actions would already have dispersed throughout the atmosphere. As such, the EPA has determined the North Slope, in its entirety, is an area of clean air resources where there are no exceedances or violations of the NAAQS, as shown in Table 5.2.2-1. In fact, the whole North Slope is designated as a Class II area of clean air that warrants special protection to avoid air quality impacts. Air quality impacts from activities associated with the Proposed Action, when combined with past actions and emissions from those actions, would not have the potential to cause a significant level of effect, and would have a negligible level of cumulative effects to onshore air quality.

Present and potential future actions of oil and gas operations on the Beaufort Sea OCS which are not associated with the Proposed Action include seismic surveys, infrastructure development, and production, and would likely have the same overall negligible onshore air quality effect as analyzed for the Proposed Action in Section 4.2.3. This is because air quality effects are not additive, meaning the impact is less than the sum of the individual effects. Thus, air quality impacts from activities associated with the Proposed Action, together with present and potential future oil and gas actions

and emissions from those actions, would not have the potential to cause major effects, and would have a negligible to minor level of cumulative effects to onshore air quality.

Present and reasonably foreseeable future actions not associated with the Proposed Action involve mainly mobile sources of emissions such as commercial travel (aircraft and vessels) related to fishing, wildlife viewing, sporting, and other recreation and tourism; temporary demolition and building of infrastructure; mining projects; and subsistence activities. Emissions from these sources would all likely have the same overall effect as mobile sources in general: mobile sources cause emissions to be discharged over time and space, spreading out the plume of pollutants. At the same time, the elongated plume is being diluted and diffused. The overall effect of emissions from mobile sources, onshore or offshore, would be mitigated at the source by the manufacturer, who is responsible for following Federal guidelines for emission standards for engines. Thus, air quality impacts from activities associated with the Proposed Action, together with other present and reasonably foreseeable future actions and mobile emissions from those actions, would not have the potential to cause major effects, and would have a negligible to minor level of cumulative effects to onshore air quality.

Present and reasonably foreseeable future actions that involve mainly stationary sources of emissions, such as operation of new infrastructure, and operating military bases, would all likely have negligible impacts even when considered together with projected emissions from the Proposed Action. Similar types of activities already occur on the North Slope, particularly near Prudhoe Bay, Alaska, where the population can swell to several thousand people as transient oil and gas workers support the Prudhoe Bay oil field, the largest oil field in the United States. The EPA has determined that operations of all the oil and gas activities, together with stationary facilities that are sufficient to support several thousand people at Prudhoe Bay, do not cause emissions sufficient to exceed or cause a violation of the NAAQS. Thus, air quality impacts from activities associated with the Proposed Action, together with other present and reasonably foreseeable future actions and stationary emissions from those actions, would not have the potential to cause major effects, and would have a negligible to minor level of cumulative effects to onshore air quality.

Climate Change

As Jacob and Winner (2009) comment, “Air quality is strongly dependent on weather and is therefore sensitive to climate change”. Climate change would affect air quality due to increasing ambient air temperatures and a weaker global circulation. With respect to the pollutant ozone, the higher water vapor content (due to higher temperatures) is expected to decrease the ozone background concentrations. Particulate matter (including black carbon) is “much more complicated and uncertain than ozone” (Jacob and Winner, 2009). Although black carbon is a small portion of the PM_{2.5} spectrum it is a contributor to climate change in Arctic regions. When black carbon is deposited on snow it reduces the reflectivity of the white snow which causes it to absorb the solar radiation and leads to a localized increase in ambient air temperatures. Changes to global circulation may lead to localized changes in precipitation levels, for some this would lead to wetter than normal conditions and others drier. Activities resulting from this Proposed Action along with other past, present, and reasonably foreseeable future actions in the Region, may have an additive effect on the impacts of climate change to air quality in the Region.

5.2.2.2. Conclusion

Possible cumulative air quality effects onshore would be mitigated due to the consistent wind velocity over the Beaufort Sea OCS (dilution and diffusion), the lack of profuse emissions from present and reasonably foreseeable future onshore and near-shore sources, and the negligible effect to onshore air quality from the Proposed Action. The overall contribution to onshore air quality impacts from activities associated with the Proposed Action, when combined with impacts from the other past, present, and reasonably future actions and emissions described in Tables 5.1.2-1 through 5.1.2-11, is negligible to minor.

5.2.3. Lower Trophic Organisms

5.2.3.1. Summary of Impacts

Effects on lower trophic organisms as a result of the Proposed Action are analyzed in Section 4.3.1 and summarized here. Impacts include habitat alterations due to benthic disturbance resulting from construction, development, and decommissioning activities. Effects would include:

- The temporary disruption of pelagic habitat from turbidity caused by suspended construction material. Burial of benthic communities with gravel and sediment from the turbidity plume could cause temporary loss of local benthic communities. Impacts of sedimentation would be more pronounced for the Boulder Patch because it is a highly specialized environment and is expected to require many years to recover from disturbances.
- The physical presence of the LDPI could provide habitat for some species that use hard substrates, including some Boulder Patch species.
- The effects of accidental spills and natural gas releases would be limited in time and space to localized populations near the source of the spill events. The number of planktonic species in the general environment and the probable dispersal rates of small spills by evaporation and through wind and wave energy in Stefansson Sound should prevent more than temporary and localized effects.

Cumulative effects may include the development of offshore oil production (i.e. Canadian and Russian development), onshore oil and gas production, construction and maintenance of infrastructure, onshore mining, and other similar activities such as trenching for telecommunication development. These activities would create further effects of discharges from nonpoint sources, sedimentary displacement and deposition, potentials for spills and natural gas releases, and activities that could further increase cumulative effects in the Proposed Action Area. Marine invasive species would be a potential risk that, if established, could affect lower trophic organisms various ways including: encrusting native habitat, competing for food sources, preying on native species, or introducing pathogens.

5.2.3.2. Discussion of Other Relevant Actions

Other relevant actions that could contribute to cumulative impacts on lower trophic organisms are listed in Table 5.1.2-2. Impacts from increases in marine vessel traffic, changes in population demographics, other oil and gas development both on and offshore, and potential for construction of infrastructure would be similar to the impacts on lower trophic organisms previously described in section 4.3.1 for analogous activities.

The influences of climate change on lower trophic levels arguably are of the most concern in cumulative effects analysis. Climate change may result in impacts to lower trophic level organisms through habitat modification and ocean acidification. Impacts on lower trophic level organisms include direct synergistic impacts such as changes in the timing and magnitude of plankton blooms, physiological changes from altered ocean pH and temperature, and habitat modification that could occur as a result of melting ice, shoreline erosion, and sea level rise. A primary impact of ocean acidification is that it depletes seawater of the carbonate compounds—aragonite and calcite—that many marine creatures need to build shells and skeletons (Fabry et al., 2008). As a result, ocean acidification hinders organisms such as corals, crabs, seastars, sea urchins and plankton from building the protective armor they need to survive. Rising acidity also affects the basic functions of fish, squid, invertebrates, and other marine species, including detrimental effects on metabolism, respiration and photosynthesis, which can thwart their growth and lead to higher mortality (Fabry et al., 2008). In addition, ocean acidification has the potential to profoundly affect the growth and toxicity of phytoplankton associated with harmful algae blooms (HABs)(Tatters, Fu, and Hutchins, 2012; Fu,

Tatters, and Hutchins, 2012). These impacts can have far-reaching effects on the structure of the food web, with some predators forced to eat non-optimal prey items. Habitat modification would expand the range for some species, while reducing it for others. In addition, the decrease of the extent of the Arctic ice pack impacts the epontic community, and subsequently, the pelagic and benthic communities. Warming ocean temperatures associated with climate change may increase all types of plankton growth rates and generation times in the region of the Proposed Action, and change the composition of lower trophic populations as warmer seas, open water and increased radiative energy from the sun increases. The effects from oil and gas activity in the reasonably foreseeable future on lower trophic levels tend to be localized to areas near the activity, and so are geographically dispersed. Although the effects of climate change would be long-term, the effects that would occur in the life of the project are not expected to considerably impact lower trophic levels.

5.2.3.3. Analysis of Cumulative Impacts

The most influential impacts on lower trophic levels historically are from activities that disturb the ocean floor. Natural impacts of ice gouging, strudel scours, and the effects of loss of landfast ice on receding shorelines are most apparent. Past anthropogenic impacts have included the discharge of drilling muds and sediments from cuttings, bioaggregation and bioaccumulation from materials released during project activities, and habitat loss. Offshore production drilling activities in the Arctic have historically used systems such as artificial islands which directly impact the sea floor and have caused direct injury and mortality to lower trophic level organisms, and disturbance leading to habitat loss. It is reasonably foreseeable that future development requiring the installation of additional platforms and subsea pipelines could occur, creating similar effects to the seafloor and lower trophic organisms. Potential discharge of cuttings also poses a threat to the benthic community's habitat through deposition of artificial sediment on the benthic surface and temporary loss of benthic organisms. Mortality and injury are also caused by the introduction of toxins and sediments into the water column due to drilling discharges. These toxins may pose a threat to pelagic and benthic organisms. Habitat loss can also result from oil and gas exploration activities that require ice breaking efforts, forcing organisms to relocate. The effects from past and present actions on lower trophic levels tended to be localized to the areas near the activity, and so are geographically and temporally dispersed.

All factors related to offshore oil and gas exploration in the Proposed Action Area that have affected lower trophic levels in the past are likely to continue in the future. Projected activities as outlined in the Proposed Action would add to the effects on these resources through both additive and synergistic (impacts that occur due to the combination of two or more other impacts, such as two or more fishing boats operating near a seal rookery) cumulative impacts. Offshore oil and gas exploration and development is likely to increase in Arctic waters of the U.S. and other countries (i.e. Russia and Canada) as the ice cover recedes and allows access to previously inaccessible areas. These activities would add to the cumulative impacts of numerous ocean floor disturbances that affect lower trophic habitat across individual localized areas. However, the continuation of offshore oil and gas exploration and production is expected to further the accumulation of persistent contaminants from multiple sources and has the potential to affect lower trophic levels in the reasonably foreseeable future. Overall effects of cumulative impacts on lower trophic resources is considered to be minor due to the reproductive capabilities of most lower trophic organisms, and the constant movement and influx of nutrients and larval stages from advection caused by currents over the Bering Sea, Sea of Anadyr, and the Arctic Ocean. Due to the extended recovery time required, some unique areas within the Beaufort Sea, such as the Boulder Patch, may have moderate cumulative impacts to habitat quality and community structure.

5.2.3.4. Conclusion

The influences of climate change on lower trophic levels arguably are of the most concern in cumulative effects analysis. In summary, the change in seasonality and decrease of the extent of the Arctic ice pack directly impacts the epontic, pelagic, and benthic communities. The positive feedback loop of warmer water temperatures and open water that absorbs more radiative energy from the sun and increased absorption of carbon dioxide results in earlier spring ice and snowmelt, decreased ice thickness during the winter, changes in hydrology of onshore ecosystems, accelerated rates of coastal erosion and permafrost degradation, and changes in ocean chemistry. These cumulatively affect change in the composition of lower trophic populations as warmer seas, open water, and increased radiative energy from the sun create changes in energy levels and nutrients available for growth and reproduction of invertebrate species. Climate change is likely to affect the habitat, behavior, abundance, diversity, and distribution of populations of marine mammals, fish, and other wildlife within the Proposed Action Area. Invasive species could spread in the affected area as a result of climate change, or from introduction through industry activities. The direct effects from the Proposed Action on lower trophic levels tend to be localized to areas near the activity, and so are geographically dispersed. The Proposed Action is unlikely to significantly individually impact the overall rate of climate change. Therefore, the cumulative impact of all actions associated with the Proposed Action to the overall condition of lower trophic levels is minor, as is the Proposed Action's contribution to all past, present, and reasonably foreseeable future action.

5.2.4. Fish

5.2.4.1. Summary of Impacts

Impacts to fish from the Proposed Action and alternatives are analyzed in detail in Chapter 4 and summarized here.

- Habitat alteration of the seafloor would disturb, damage, and bury fish habitat and sessile fish prey, resulting in mortality for individuals of some fish species unable to escape burial.
- The physical presence of the LDPI could affect available habitat and habitat type.
- Sounds associated with all phases of the Proposed Action may impact fish behavior.
- Construction of ice roads may alter habitat for freshwater fishes, resulting in localized removal of fish from ponds used for freshwater withdrawal.

All of these impacts are expected to be localized and temporary, except for the LDPI which would be a long-term alteration to 0.01% of Stefansson Sound.

- Marine invasive species would be a potential risk that, if established, could affect fish habitat and fish in various ways including: encrusting native habitat, competing for food sources, competing for spawning grounds, preying on native species, or introducing pathogens.

These effects could lead to changes in community structure and shifts in abundance and diversity of native species.

- Accidental small refined spills (<1,000 bbl) could affect behavior and physiology of sensitive life stages of fish species in localized areas of surface water which could lead to chronic or acute toxicity. Large spills would affect fish species in or near the path of oil through acute effects and long-term chronic effects. The effects would depend on several factors including life stage of fish species, distribution and abundance in water column or benthos, and timing of migrations and spawning.

5.2.4.2. Discussion of Other Relevant Actions

The Proposed Action could add incremental impacts to the environment when added to other past, present, and reasonably foreseeable actions affecting the U.S. Beaufort Sea. Other relevant actions that could contribute to cumulative impacts on fish are listed in Table 5.1.2-1. Addition of cumulative impacts from other oil and gas development both on and offshore, and potential of construction of infrastructure would likely be minor. Commercial fishing, though not currently authorized in the U.S. Arctic, may impact the area in the future. Research activities in the future would likely remain relatively consistent with past and present levels, though cumulative additions due to longer open water seasons and changes in onshore hydrology are possible. The effects from oil and gas activity in the reasonable foreseeable future on fish tend to be localized to areas near the activity, and so are geographically dispersed.

The influences of climate change on fish must be considered in the cumulative effects analysis. Climate change is likely to affect the habitat, behavior, abundance, diversity, and distribution of fish. Several studies have examined the effects of climate change (including ocean acidification) on fish. These studies emphasize the implications of potential northern range expansions of fish species, the effects of warming sea surface temperatures on fish biomass, possible changes in fish species complexes, effects on commercially important species, shifts in prey availability and shifts in food webs, and the particular vulnerability of coastal areas in Alaska (Cheung et al., 2009; Sherman et al., 2009). Shifts in the food web as a result of changing climate could result in major ripple effects on fish, with some predators forced to eat non-optimal prey items, or preferred feeding spots becoming unavailable. Some species may benefit from climate change shifts in the environment. Rising ocean acidity also affects the basic functions of fish, squid, invertebrates, and other marine species, including detrimental effects on metabolism, respiration and photosynthesis, which can thwart their growth and lead to higher mortality (Fabry, et al., 2008). The decrease of the extent of the Arctic ice pack impacts the lower trophic communities, which has impacts on fish communities. Warming ocean temperatures associated with climate change may increase all types of plankton growth rates and generation times in the region of the Proposed Action, and change the composition of lower trophic populations as warmer seas, open water, and increased radiative energy from the sun increases. Although the effects of climate change will be long-term, the effects that would occur in the life of the project are not expected to considerably impact fish.

5.2.4.3. Analysis of Cumulative Impacts

Reduction in the extent and duration of sea ice may increase the potential for commercial fishing in the U.S. Arctic; however, under the Arctic Fishery Management Plan, commercial fishing is currently prohibited in the U.S. Arctic (north of Bering Strait). If commercial fishing were permitted in the future, it would likely be managed by NMFS or the Alaska Department of Fish & Game.

Several studies have examined the effects of climate change (including ocean acidification) on commercial fisheries. These studies emphasize: the implications of decreasing Arctic sea ice; potential range expansions of fish species into the Arctic; the effects of warming sea surface temperatures on fish biomass; possible changes in fish species complexes; effects on commercially important calcareous species; shifts in prey available and shifts in food webs; and the particular vulnerability of coastal areas in Alaska (Amundsen, 2013; Cheung et al., 2009; Mathis et al., 2014; Mann, Cott, and Horne, 2009; Sherman et al., 2009).

The primary effects of commercial fishing would be the removal of fish from the ecosystem along with potential disturbances and contamination from the presence and operation of commercial fishing vessels.

Fish in the Beaufort Sea and nearshore areas could be affected by increasing vessel traffic from global shipping vessels, oil and gas vessels, cargo vessels, military vessels, supply barges, cruise ships,

commercial fishing vessels, survey vessels, and research vessels. Increased shipping increases the occurrence of small spills, the risk of introducing aquatic invasive species, and the possibilities of oil spills or vessel groundings, all of which would affect fish, fish habitat, and fish prey.

Installation of offshore telecommunications cables would cause additional bottom habitat disturbance from surveying (current), trenching, and laying fiber optic cable (foreseeable future) north through the Chukchi Sea to Prudhoe Bay and northeast through the Canadian Arctic.

Onshore development and mining activities, to include associated construction and maintenance projects and facilities, would affect fish, fish habitat, and fish prey via stream, pond, and lake habitat alteration; water withdrawals; permitted discharges; construction of support facilities; construction of roads, ice roads; and construction of pipelines.

5.2.4.4. Conclusion

The influences of climate change on fish are of the most concern in cumulative effects analysis. As described in Section 5.2.3, the change in seasonality and decrease of the extent of the Arctic ice pack directly impacts lower trophic communities that make up the prey species for fish. These cumulative changes in the composition of lower trophic populations create changes in energy levels and nutrients available for growth and reproduction of higher trophic predators, such as fish. Climate change is likely to affect the habitat, behavior, abundance, diversity, and distribution of populations of marine mammals, fish, and other wildlife within the Proposed Action Area. The direct effects from the Proposed Action on fish tend to be localized to areas near the activity, and so are geographically dispersed. The Proposed Action is unlikely to significantly individually impact the overall rate of climate change. The Proposed Action would contribute minor to moderate impacts to fish in addition to the impacts from past, present and reasonably foreseeable actions noted in Table 5.1.2-2.

5.2.5. Birds

5.2.5.1. Summary of Impacts

Routine operations associated with the Proposed Action are analyzed in Section 4.3.3 and expected to impact birds, including in the following ways:

- Collision hazards would be associated with the physical presence of new facilities, including the LDPI, the onshore pipeline, and associated vessels.
- The bright artificial lighting of the LDPI (i.e., ambient and occasional gas flaring) and some larger support vessels that may remain in the marine environment for extended periods (e.g., assist tug) would cause attractions, disorientations, and potentially exhaustion and increased levels of collisions when certain environmental conditions are present during migration.
- Increased predation would be associated with new facilities and increased human presence that indirectly subsidizes avian predators.
- Traffic, including vehicles, aircraft, and, to a lesser extent, vessels, would disturb and displace birds, in particular breeding waterfowl and staging shorebirds and waterfowl.

Certain declining population or limited-population species, including rusty blackbird and buff-breasted sandpiper are among those of the many at risk of collision. The long-term presence (i.e., life of the Proposed Action) of these facilities and support vessels ensures that these collision hazards would be on-going, long-lasting and, due to the migratory nature of these birds, wide-spread. Collision hazards associated with the Proposed Action may reach a moderate level of impact for some avian species, including listed spectacled eider, should there be chronic or eventual mortality levels that are relatively large proportional to their declining or small population sizes.

Minor to moderate levels of impact would be expected from increases in predator abundance, because the increases would be long-term, and the effects on nesting populations, while originally somewhat localized, would also be on-going and long-term.

5.2.5.2. Discussion of Other Relevant Actions

There are a variety of factors that influence bird populations in the Beaufort Sea region. The great majority of birds that occur in the Proposed Project Area are migratory, spending much of each year in distant regions where they may be subject to additional environmental impacts outside the scope of the present analysis. Many of the relevant past, present, and reasonably foreseeable future actions and events of the Arctic that could contribute to cumulative impacts on birds are listed in Table 5.1.2-2. Routine oil and gas exploration and development on the Chukchi and Beaufort Seas and on the ACP, together with increased recreation/tourism/hunting, fishing and regular commerce and transport, would increase the presence of humans and infrastructure and associated potentials for the same types of impacts that birds, such as tundra-nesting birds including eiders, have experienced and/or are currently experiencing. These include: predator population growth and collision risk, disturbance and displacement from vessel, aircraft, vehicle traffic and operation of heavy equipment, discharges/habitat alteration, and risk of encountering oil spills.

The greatest source of impact to birds associated with reasonably foreseeable future actions and events in the Proposed Action Area may be from climate change (Wauchope et al., 2016; Liebezeit et al., 2012). Climate change is anticipated to impact global environments, but particularly the Arctic environments of birds in many ways. These include, but are not limited to, causing more frequent and severe storm surges and inundations of low lying coastal habitats; destabilizing permafrost, leading to replacement of terrestrial habitat with thermokarst ponds (Shur et al., 2003) and geomorphological hazards and slope instabilities (Berteaux et al., 2017); and causing snow cover to melt and disappear in the spring earlier, exposing prey and habitat out of synchrony to that of the ecology of migratory species (Therrien et al, 2015).

Other local (i.e., Beaufort Sea region) anthropogenic impacts in the past and present include lead poisoning and hunting, increased abundance of predators, collisions, habitat alteration, and disturbances. For example, birds, especially waterfowl, are known to ingest spent lead shot that washes from uplands and persists for years in freshwater wetlands, leading to death from poisoning. Exposure dangers have been so substantial that lead shot was federally banned for waterfowl hunting in 1991, and prohibited by the State of Alaska Board of Game for upland game bird hunting on the Arctic Coastal Plain (ACP) in 2006. Lead shot poisoning remains a threat to waterfowl on the ACP: lead shot can persist particularly long in arctic wetlands due to the underlying ice barrier that prevents it from sinking out of reach of foraging birds, and it also apparently remained locally available for subsistence hunting use even after the bans were imposed (USFWS, 2010).

Besides lead poisoning and hunting, various local populations of tundra-nesting avian species may also have begun to experience long-term impacts from increased levels of predation. In particular, growing numbers of foxes, gulls, and ravens that feed on eggs and chicks appear to have benefited from increased access to human foods and structures that these predators use for denning, nesting, and perching.

Another persistent impact from the increase of infrastructure and human use is collision mortality: numerous species of birds, including passerines, sea ducks, seabirds, shorebirds, and other waterfowl such as geese are known to regularly collide with existing artificial island and onshore oil and gas facilities, vessels, power lines, and other structures and be killed. Collisions documented thus far have been for up to tens of individuals or less than ten flocks of tens per species per year, but not all collisions are documented, and these encounters, due to bird migration/weather interaction phenomena, can be highly episodic in nature.

The development of roads, oil and gas facilities, and other infrastructure has also reduced and fragmented some areas of tundra and pond-nesting habitat. These habitat alterations have thus far affected primarily only small areas of breeding and foraging habitat relative to what is available to most species on the ACP or offshore Beaufort Sea, but they would be long-lasting.

Past, present, and reasonably foreseeable onshore and offshore development and its associated vehicle, aircraft, and vessel traffic disturbs or would disturb foraging, nesting, and migrating birds. Further, it is possible that some individual birds have been harmed by small spills.

5.2.5.3. Analysis of Cumulative Impacts

As stated above, birds in the Proposed Action Area have been exposed to activities that have impacted them in the past. The activities that produce these effects are still present and are likely resulting in on going impacts as discussed above including disturbance, habitat alteration, and mortality.

The effects of routine oil and gas exploration and development activities that may occur in the Beaufort Sea as well as increased recreation/tourism/hunting, fishing, and regular commerce and transport, are expected to be similar to the impacts on birds described in Section 4.3.3 for analogous activities. These include increases to the local levels of avian predation, physical presence and sound disturbances from vessel and aircraft traffic, habitat alteration, and collision hazards and small spill hazards. Impacts are anticipated to be primarily localized relative to the general proportions of populations of many species, although they can be more widespread in habitats where significant numbers aggregate. Some activities that repeatedly or annually impact the same population would also be on-going and long-term.

The largest anticipated source of harm to birds associated with reasonably foreseeable future actions and events is climate change. For example, some species are anticipated to eventually experience breeding habitat loss, including the low-lying barrier-island nesting common eider affected by storm surges, tundra-nesting species such as buff-breasted sandpiper losing habitat to pond development or shrub advancement (Lanctot et al., 2010) and cliff-nesting raptors like rough-legged hawk affected by slope instabilities (Gauthier et al., 2011; Beardsell 2016). The productivity of buff-breasted sandpipers and other shorebird populations likely already in decline could be further negatively affected by loss of synchronous timing between their Arctic breeding season and prey availability (Lanctot et al., 2010). Species of seabirds that depend on ice for their marine-foraging are also expected to be impacted. There is evidence that some tundra-nesting birds rely on the presence of alternative prey (i.e., lemmings) as a cue for spring settlement and nest initiation. Fewer rodent peaks are predicted under a changing climate regime, and the loss of this reliability could therefore impact productivity of some species, including shorebirds (Saalfeld and Lanctot, 2015; Fraser et al, 2012). Other climate-change related impacts may be anticipated, such as increased rates of vessel-associated impacts as the ice cover melts earlier and forms later, in turn increasing rates and areas of vessel access.

Other anticipated substantial sources are increased levels of predator abundance associated with multiple infrastructure and industrial use sites, and possibly for a few species, collision risk from bird encounters with vessels, platforms, and other infrastructure. In the absence of the Proposed Action, the impacts to most species of birds would likely be moderate because they would be long-lasting but less than severe.

Ingestion of lead shot, hunting, and changes in predation patterns have been suspected as primary contributors to the past substantial declines experienced by some populations of tundra-nesting birds (e.g., spectacled eider, Steller's eider) (USFWS, 2016, 2010, 2002). Tundra-nesting waterbirds, particularly eiders, are believed to have been the most impacted avian species from the effects of past

and present actions. Most of these impacts have been persistent and widespread, although some of the causal factors have somewhat abated and some populations have stabilized, but at a lower level.

In the absence of the Proposed Action, the activities that produce these effects on birds are still present, and result in disturbance, habitat alteration, reduced productivity, and mortality. Because they are collectively long-lasting and occasionally widespread, but less than severe, past, present, and reasonably foreseeable future actions cause a minor to moderate impact on birds, depending primarily on species and location.

5.2.5.4. Conclusion

Impacts associated with the Proposed Action, including physical presence of vessels, aircraft, vehicle traffic, or drilling facilities, including mortality from birds encountering vessels and structures; discharges, and small spills, are localized and most would not persist from season to season. Habitat alteration impacts would be localized. Decreased levels of productivity from higher predator abundance associated with increased human presence and infrastructure construction/presence over the life of the Proposed Action are generally localized but could result in a more widespread and long-lasting level of effect for a few vulnerable species. Added together, the resultant impact of the Proposed Action to birds would remain minor for most avian species; impacts would be long-lasting and widespread, therefore moderate, for a few vulnerable (declining and limited-population) species and ESA-listed spectacled eider.

The cumulative impact that results from the incremental impact of the Proposed Action when added to other past, present, and reasonably foreseeable future actions is expected to be moderate for an array of avian species. The Proposed Action, when added to existing and reasonably foreseeable future effects and actions, is not expected to contribute measurably to the cumulative impacts to birds. This is primarily because of the chronic and swamping effects of climate change for which Arctic birds have a particularly high exposure rate, as well as other cumulative impacts including those from lead shot, multiple other infrastructure projects, and their disturbance, predation, collision risk, habitat alteration, and other effects.

5.2.6. Marine Mammals

5.2.6.1. Summary of Impacts

Impacts to marine mammals from the Proposed Action are analyzed in detail in Section 4.3.4 and summarized here. Potential effects include:

- Disturbance and displacement from the physical presence of and noise produced by marine, air and ground transportation and by construction, maintenance, and decommissioning activities
- Habitat loss and alteration
- Human-wildlife interactions
- Small spills

Most effects to marine mammals would be localized and negligible to minor.

Vessel and aircraft traffic would occur shoreward of the waters where beluga, bowhead, and gray whales typically occur; likewise the proposed LDPI site and offshore pipeline corridor are located inshore of the areas where these species are generally seen. Disturbance and displacement of whales from project activities and associated traffic would be transitory. The Proposed Action is expected to result in negligible loss or alteration of cetacean habitat since the proposed LDPI and pipeline corridor are inshore of areas where whales generally occur and the proposed LDPI is miniscule in comparison to the overall habitat available in the Beaufort Sea. The greatest effect to cetaceans would arise from noise generated by pile-driving and vessel traffic during island construction, which could

result in whales, including migrating bowhead whales, being deflected offshore. Mitigation, detailed in Appendix C, such as timing restrictions on noise-generating activities during the fall bowhead migration, could minimize these potential effects.

Pacific walrus occur rarely in the vicinity of the Project Area and thus are unlikely to be affected by Proposed Action activities. The greatest effector to any walrus that may be seasonally present in the area would be due to disturbance and displacement from noise generated by pile-driving during island construction, and by vessel and aircraft traffic. Mitigation, detailed in Appendix C, such as timing restrictions, minimum flight altitudes, and vessel speed restrictions could minimize disturbance and displacement effects.

For bearded seals, vessel and aircraft traffic would be the greatest effector because these activities would occur in waters where this species is present and would persist annually through the life of the Proposed Action. Traffic along proposed transit corridors could result in long-term displacement of individual seals from these immediate areas, although seals are likely to habituate to vessels and aircraft. Mitigation measures, detailed in Appendix C, such as minimum flight altitudes and vessel speed restrictions, could minimize these potential effects.

Because ringed seals winter over and produce pups in the Proposed Action Area, the greatest potential impacts to ringed seals from the Proposed Action would come from pipeline installation activities. The portion of the offshore pipeline corridor in deeper water (i.e., further from shore) overlaps with sea ice habitat suitable for pupping lairs as well as breathing holes. Noise from installation activities could disturb and displace individual seals, and the activities themselves could reduce the quality and availability of the small amount of habitat immediately alongside of the pipeline corridor. Heavy equipment transport could also crush or collapse lairs, resulting in injury or mortality of pups and mothers. The direct effects of pipeline installation activities would not persist for longer than one season. Mitigation, detailed in Appendix C, such as pre-activity surveys and subsequent avoidance of known lairs, would minimize these potential effects.

Polar bears occur year-round in both the on- and offshore portions of the Proposed Action Area, typically in low population densities. Polar bears are most likely to be affected by winter construction activities, including ice roads, gravel mining, LDPI construction, and pipeline installation. A small amount of habitat could be lost or altered for the duration of the activity. Individual bears could be disturbed or displaced from the immediate vicinity. Alternately, construction activity could attract bears, creating potential for human-wildlife interactions with negative consequences for both workers and bears. Ice road construction and use in denning habitat after bears have entered maternal dens would be the greatest effector for polar bears. Construction activities could disturb mothers, causing them to abandon dens prematurely, and heavy equipment transport and use could crush or collapse dens, resulting in individual injury or mortality. Mitigation, detailed in Appendix C, such as pre-activity surveys and subsequent avoidance of known polar bear dens, could minimize these potential effects.

As discussed in Section 4.3.4.6.1 (Oil Spills, Small), Small spills would be localized and would dissipate rapidly. As such, they would be unlikely to contact marine mammals.

5.2.6.2. Discussion of Other Relevant Actions

Oil and Gas Activities: Due to the number of different marine mammal species analyzed in this section, specific activities and their relationships to the cumulative effects on each species are discussed separately where appropriate.

Oil and gas exploration, development, production, and decommissioning activities have occurred in the U.S. Beaufort Sea since the 1970s with no residual effects on marine mammals in the area.

Future oil and gas activities in the Beaufort Sea are likely to concentrate in the vicinity of nearshore state and Federal leases. Canada is also expected to develop its own offshore oil and gas resources to the fullest extent. Gearon et al. (2014) modelled the spread of spills originating in the eastern Beaufort Sea, and found that oil from a theoretical 5.4 million bbl loss of well control could contact some Beaufort and Chukchi Sea nearshore areas. Such events would be highly unlikely considering the geology, reservoir sizes, water depths, and pressures involved in Arctic wells. Spills in Canada or Russia large enough to induce marine mammals to disperse to other areas could result in animals moving into the Proposed Action Area.

Transportation: Vessel traffic in the Arctic marine environment has historically been associated with subsistence hunting, travel between coastal communities, commerce, tourism, research, oil exploration, and some military activities.

Vessel traffic passing through the Bering Strait and into eastward into the Beaufort Sea has increased in recent years (Clarke et al., 2014), and may continue to increase into the foreseeable future, potentially adding more noise into the marine environment and increasing the risks of strikes to marine mammals. Species that may be encountered around Dutch Harbor and on transit to the Proposed Action Area include the following species: bowhead whales, fin whales, humpback whales, North Pacific right whales, sperm whales, gray whales, blue whale, minke whales, killer whales, beluga whale, Stejneger's beaked whale, Baird's beaked whale, Cuvier's beaked whale, dall's porpoise, harbor porpoise, and Pacific white-sided dolphin. Several of these species are discussed in more detail below. Impacts to from vessel traffic associated with the Proposed Action and other reasonably foreseeable future actions could include vessel strikes and small fuel spills.

Aircraft traffic has also increased across the North Slope, generally in support of commercial, government, academic, and military activities. More aircraft are associated with recreational activities, and these numbers should continue to grow, although most such flight activity would occur over onshore areas. Similarly, commuter and emergency flight activity continues to grow. Though increases in onshore air traffic are occurring, the increases remain proportionately low with respect to existing air-traffic levels.

Subsistence: Seals, bowhead whales, and other marine mammals are harvested annually in subsistence hunts. Numbers of animals harvested varies by community and hunting areas typically radiate out from each community for many miles with each community representing a particular subsistence area. Impacts to marine mammal populations are local and vary by region.

Scientific Research: Research-oriented aircraft and vessel traffic impacts to marine mammals generally occur during the open water season (July-October). On-ice research usually occurs in winter and early spring, but may also occur on pack ice during the open water season. These activities are limited in the amount of disturbance they produce due to the small footprint of their operations, the limited amount of potential disturbance created, and the limited duration and magnitude of fieldwork.

Studies conducted in the OCS tend to be non-invasive and include activities such as radio-tagging, aerial observations, etc.

Climate Change: Climate change in the Arctic is the driving factor behind increased vessel traffic, air traffic, military activity, and some economic development and is expected to have substantial effects on Arctic marine mammals. The effects of climate change on marine mammals could be partially beneficial to certain species of marine mammals while detrimental to others, depending on what life processes are affected for a species and the manner in which those effects occur.

Reasonably foreseeable changes to the Arctic climate include increased temperatures, increased sea ice losses, increased glacial ice melt, earlier and faster snowmelt, extended growing seasons, shortened winters, and increased precipitation.

Melting permafrost can also create melt ponds and lakes on tundra in low lying areas. Such catchments of soil moisture are unlikely to directly flow into streams and may be ephemeral. Rivers and streams along the Arctic Coastal Plain (ACP) could also undergo impacts from changes to the climate with earlier spring flooding (Nghiem et al., 2014; Beltaos, 2013; Queenie et al., 2012) followed by decreases in groundwater inputs derived from melting snow, ice, and permafrost (Qiu, 2012). Spring and summer flooding of river systems can lead to large influxes of warmer freshwater into the Arctic marine environment. If such events occur in a rapid surge as opposed to a steady inflow, extensive areas of sea ice can rapidly melt (Nghiem et al., 2014).

Sea ice losses in the Arctic Ocean may lead to larger storms, resulting in larger waves that weather away coastlines and islands more rapidly (Vavrus, 2013), resulting in larger and more frequent storm surges reaching farther inland from the coast. Storms and storm surges, along with warming air, could increase thawing of permafrost in Arctic soils and increase the annual depth of thawed soils (Kittel, Baker, Higgins, and Haney, 2011; Vavrus, 2013), leading to the release of soil organic matter into watersheds. Nearshore areas of the Beaufort and Chukchi Seas would receive larger surges of organic influxes from eroding coastlines, streambanks, and from the thawing permafrost that would add organic constituents to the marine food web.

Ocean acidification would continue as a result of climate change, and would affect the levels of calcium carbonate available to invertebrates for shell development. Under such conditions, benthic creatures such as bivalves (such as clams and mussels) and polychaete worms (having fleshy segments and bristles – bristleworms) would have difficulty creating and maintaining shells, while species such as jellies, squid, etc. might flourish. At the microbial level, blue-green algae could have trouble creating the calcium carbonate matrices needed to permit them to remain near the surface of the ocean, and such a situation could have severe repercussions throughout the oceanic food web (Raven J. et al., 2005; Riebesell and Tortell, 2011).

Both summer and winter temperatures are expected to increase across the North Slope through this century, with the greatest changes occurring in winter. Average winter temperatures are likely to increase by as much as 12.6°F (7°C) by the 2040s, while summer temperatures are projected to rise by about 5.4°F (3°C) by the 2040s (Scenarios Network for Alaska and Arctic Planning, 2011**updated using SNAP tool <https://www.snap.uaf.edu/> accessed April, 2017). Precipitation patterns are also expected to change with 20-45% increased winter precipitation by the 2040s; while summer precipitation increases would be smaller. A northward shift in thaw dates is expected over the course of the century with thawing occurring in the coastal regions during the first week of June by mid-century and June 1 by the end of the century while thaws would occur around May 1st in the southern NPR-A. In comparison, fall freeze-up dates along coastal areas would extend into late September, and October 1st in the Brooks Range.

5.2.6.3. Analysis of Cumulative Impacts

Beluga Whale

Beluga whale populations exist in other ice-free waters, so it is likely that they could exist in an ice-free summer arctic; shrinking sea ice could draw beluga whales farther north with the ice front. They would continue feeding on appropriate fish species as long as those stocks remain abundant. Once existing prey stocks decline, belugas would likely switch to other prey species that become available. A total loss of sea ice over the Arctic Ocean during the summer months could permit different beluga and narwhal stocks to mingle. Loss of sea ice may also result in increased predation on belugas that had formerly been able to avoid killer whales by swimming under and through ice floes.

Due to their dispersal across the Chukchi and Beaufort Seas, particularly areas beyond the continental shelf break, belugas would not be impacted by most of the effects of oil and gas development short of a VLOS.

It is assumed that later in the 21st century as summer sea ice recedes north there would be no need for icebreaking during the July-October period. Though the ice-free season would likely extend out a few weeks from present dates, there are no known oil or gas reserves under the deep waters of the Arctic Basin where most belugas would be concentrating. Consequently, the effects of icebreaking on beluga whales should decrease into the future due to a decreasing need for such activities.

As summer sea ice recedes, shipping lanes are likely to open, resulting in greater commercial and scientific vessel traffic passing through beluga whale habitat. It is assumed in this analysis that Belugas can detect and avoid most commercial vessel traffic. Vessels associated with military operations could include surface ships and submarines. Submarines are capable of operating under sea ice just as they have in the past, but their presence could become more common in the future as military activities increase in the Arctic.

Other military activities could include aircraft operations using jets and helicopters, in addition to the types of aircraft that are normally used on the North Slope. Jets often operate at supersonic speeds which introduce much more noise into the environment than propeller-based aircraft, and helicopters create a different type of noise disturbance than fixed wing aircraft.

Positive changes in the economic conditions among subsistence-dependent peoples may lead to hunting forays that travel greater distances, increase in duration and potentially find larger harvests, in places that were previously relied upon as safe refuge areas by belugas, increasing stress on beluga stocks.

Climate change effects to the Chukchi and Beaufort Seas would have a greater impact on beluga whale numbers, distribution, and population viability than all of the past, present, and foreseeable human activities combined. The effects of the Proposed Action on beluga whales would not appreciably add, or synergistically interact with other past, present, or reasonably foreseeable future activities, or climate change, to alter the condition of beluga whale stocks in the 21st century.

Bowhead Whale

Bowhead whales may experience positive effects from climate change in the 21st century due to increased productivity and longer open water seasons. Earlier melts of sea ice in spring could permit bowheads to migrate a few weeks earlier and a total loss of summer sea ice over the Arctic Ocean could permit different bowhead whale stocks to mingle. Diminishing ice may also allow predators such as killer whales to more efficiently hunt bowheads, since bowheads have been known to swim under heavy sea ice cover where killer whales cannot follow. Climate change effects in the Chukchi and Beaufort Seas would have a greater impact on bowhead whale numbers, distribution, and population viability than all of the past, present, and foreseeable human activities, including the Proposed Action, combined.

Commercial vessel traffic is the human activity likely to have the greatest effect on bowhead whales, through vessel strikes. Increasing vessel traffic in the Arctic would no longer be restricted to the Northwest Passage or the Northern Sea Route, which is presently open for limited periods of time. For bowhead whales, the consequences of prolonged ice-free Arctic waters would be more large commercial and tourism vessels passing through their feeding grounds in the Eastern Beaufort Sea, Barrow Canyon, and off the coast of Chukotka. This could impact bowhead whales passing through the Bering Strait during spring or fall migrations if the migrations fall out of synchronization with the fall formation and spring melt of sea ice in the northern Bering and southern Chukchi Seas. The effects of the additional vessel traffic could include increased vessel strikes of bowhead whales, and increased noise production into the marine environment. Under such conditions there would be no need for icebreaking during the July-October period, and the use of icebreakers would decline.

Other forms of vessel traffic include support for scientific surveys, which are likely to increase into the future, along with subsistence activities. It is assumed for this analysis that Bowhead whales

would be capable of avoiding survey ships. Small watercraft used for subsistence, particularly whaling, may operate for longer periods of time due to increased financial resources among some subsistence users. Weather and sea ice have profound effects on whaling in the Arctic. If summer Arctic waters become ice free, bowhead fall migrations may shift north, beyond the reach of subsistence whalers. With larger, more frequent and powerful storms expected to occur in the Arctic Ocean as the 21st century progresses, people engaged in whaling in open water could be at a greater personal risk. Moreover, stormy weather may shorten the time available for whaling activities or make subsistence whaling unfeasible.

The effects of the Proposed Action on bowhead whales would not appreciably add to or synergistically interact with other past, present, or reasonably foreseeable future activities to alter the condition of the Western Arctic Bowhead Whale stock in the 21st century.

Gray Whale

Earlier and more extensive sea ice losses during the summer months in the Beaufort and Chukchi Seas would affect gray whales by opening up more habitat for them to occupy, particularly in the northern Chukchi Sea. As the marine environment shifts towards a more pelagic system, fish could become more favored by gray whales than benthic prey. Gray whales feed on benthos, and larger fish stocks may be less favorable for them; however, some gray whales remain in the Bering Sea and near Washington State and British Columbia, feeding on fishes and invertebrates during summer. Such differences can be explained as generalist feeding behavior that permits gray whales to exploit the most easily obtainable food resources; feeding flexibility is also likely considering the documented maneuverability of gray whales (Pyenson and Lindberg, 2011; Woodward, Winn, and Fish, 2006). When the Arctic Ocean becomes ice free during the summer, gray whales from the North Pacific may venture into the Atlantic Ocean (documented twice since 2008), potentially recolonizing certain areas. Climate change effects in the Chukchi and Beaufort Seas are likely to have a positive, greater, and more profound impact on gray whale numbers, distribution, and population viability than all of the past, present, and foreseeable human activities in the Beaufort Sea combined.

Summer sea ice losses in the Arctic Ocean would permit increasing numbers of commercial, tourism, and scientific vessel activity. The growing numbers of scientific and commercial vessels would increase the noise and risk of vessel strikes. U.S. Navy and Coast Guard vessel presence, including submarines, in the Chukchi and Beaufort Seas may also increase.

Commercial, military, and scientific aircraft operations are also expected to increase into the foreseeable future. Greater use of military jets and helicopters would introduce more noise, though most military aircraft maintain an altitude of several thousand feet above the water or land surface which minimizes the disturbance to the marine environment. Scientific surveys using aircraft such as the ASAMM, BOWFEST, BWASP, etc. fly at altitudes sufficient to negate most transfer of sound into the water. Aircraft operations should have negligible effects on gray whales.

Climate change effects to the Chukchi and Beaufort Seas would most likely have a positive effect on gray whales; one that is greater than all of the past, present, and foreseeable human activities combined. The effects of the Proposed Action on gray whales would not appreciably add to, subtract from, or synergistically interact with other past, present, or reasonably foreseeable future activities, or climate change, to alter the condition of gray whales in the Arctic during the 21st century.

Pacific Walrus

The USFWS considers Pacific walrus to be extralimital to the Proposed Action Area. Pacific walrus populations were severely depleted during the commercial hunting period of the late 19th and early 20th centuries. The Congressional Walrus Act of 1941 banned U.S. commercial walrus hunting, though Russian commercial hunting of walrus continued for some time after that. By the 1950's, Pacific walrus populations were between 50,000 and 100,000 animals. The MMPA of 1972 banned

all sport hunting of walrus. Alaska Native subsistence hunters currently take an average of about 1,250 Pacific walrus are taken per year.

Reductions in sea ice duration and extent are causing changes in patterns of walrus habitat use and resulting in the formation of large terrestrial haulouts along the Chukchi Sea. Walrus onshore may be more vulnerable to predators and to disturbance events that cause stampedes, resulting in injuries and mortalities. Young calves are particularly vulnerable during stampedes, and these events could lead to population level effects (Fischbach et al., 2009; Udevitz et al., 2013). Terrestrial haulouts are common on the Russian Chukotkan coastline and were historically present to a moderate extent along the Alaska coast, although no large terrestrial haulouts existed on the U.S. Chukchi or Beaufort Seas Coasts prior to 2006 (Robards and Garlich-Miller, 2013). 2007-2014 have seen larger terrestrial aggregations of walrus at onshore haulouts along both sides of the Bering Strait that correspond with dramatic summer sea ice retreat (Garlich-Miller et al., 2011; Jay and Fischbach, 2008; Jay, Fischbach, and Kochev, 2012; Robards and Garlich-Miller, 2013).

Young calves are particularly vulnerable to long periods without a haul out because they do not thermoregulate as well as adults. Once onshore, females with calves must either forage in sub-optimal near shore areas or make long transits to offshore feeding habitats with their calves. Increased use of terrestrial haulouts may result in localized prey depletion, as foraging areas nearest to haulouts could become over-grazed (Garlich-Miller et al., 2011; Jay, Fischbach, and Kochev, 2012). Declines in local prey populations could result in adverse impacts to individual fitness. These impacts could persist over multiple years; the severity of impacts and likelihood of population level effects would be dependent on many factors, including the recruitment rate of prey species and degree of walrus' reliance on specific terrestrial haulouts. Onshore, walrus are more sensitive to disturbance events, which may result in trampling injuries and mortalities. Ocean acidity, temperature, and sea ice cover changes may lead to impacts on the availability of benthic invertebrate prey (Section 5.2.3).

Increases in shipping and icebreaker traffic, particularly if it transits near shore-based terrestrial haulouts, may increase disturbance events and result in mortalities from ship strikes or prop injuries. Calves may be separated from their mothers during disturbance events onshore or on ice. Calves remain dependent upon their mothers for two years or more, and once separated from their mothers, calves would not survive. Low flying aircraft may also cause disturbance events and stampedes, particularly at shore-based haulouts.

Walrus are increasingly coming into contact with vessels while in the Bering, Chukchi, and Beaufort Seas as research, shipping, and industrial activities increase. This increased potential for human disturbance occurs as sea ice habitat is decreasing and food resources may be declining due to climate change. Industry activities may require additional MMPA mitigation measures or may not be authorized under the Beaufort Sea MMPA Incidental Take Regulations.

Polar Bear

Prior to the passing of the MMPA, sport hunters took large numbers of polar bears in the U.S., with population level impacts. Polar bear numbers increased after the 1972 passing of the Marine Mammal Protection Act (MMPA). Current levels of anthropogenic activity related to the oil and gas industry in Alaska result in occasional disturbance of individual bears, generally due to vessel, aircraft or ground traffic or due to hazing bears away from human activity or habitation, which also occurs near villages in Alaska and Chukotka. Some polar bears are taken in defense of life or through subsistence hunting. In 2013, for example, a total of 52 bears were taken by subsistence hunters in Alaska from the Southern Beaufort Sea Stock (SBS) and the Chukchi-Bering Sea Stock (CBS) polar bear populations (USFWS, 2014a).

Commercial shipping, tourism cruises, and research cruises are increasing in the Arctic and are projected to continue to increase, including icebreakers used for all three purposes. As sea ice retreat

makes the Northwest Passage and the Northern Sea Routes more viable for tourism and cargo vessels, more vessels are expected to access these routes throughout the longer open water season. The increase in vessel traffic increases the potential risk of accidents and spills. While individual icebreakers are unlikely to alter the sea ice habitat during the freeze-up period or in winter, increased icebreaker traffic during the spring melt season, combined with reduced sea ice, may result in smaller floes after icebreaking that melt more quickly, reducing the availability of sea ice for marine mammals to rest on. Where icebreakers repeatedly traverse a specific route, for example, to keep it open for access by other vessels, changes in the ice formation along the edges of the artificial lead may result in the lead remaining open longer (Mahoney et al., 2012).

Arctic sea ice extents have shown a decreasing trend for all months from 1979 to the present and are expected to continue decreasing (Stroeve et al., 2012). The decrease in September sea ice extent combined with other factors leads to thinner first year ice cover in spring. As the warming trend continues, Arctic sea ice cover may be limited to first year ice with little or no multi-year ice extending into the Chukchi Sea (Zhang and Walsh, 2006). As the open water period increases, many polar bears would spend more of the year in sub-optimum foraging habitat. Bears would either come ashore or remain with the sea ice as it moved northward off the shelf and over waters that are not inhabited by their prey species. Onshore, bears may fast or feed on marine mammal carcasses, which may bring them increasingly into conflict with humans near villages with food. Human-bear conflicts in villages in the Chukotka region and on the Alaska North Slope have led to the formation of 'bear patrols' in an effort to haze bears away from villages rather than destroy them to protect human life. Bears on sea ice that has retreated off of the coastal shelf may fast for long periods. They may also be forced to attempt long distance swims to shore or other available sea ice as melting ice breaks up in summer (Pagano et al., 2012). The Southern Beaufort Sea population of polar bears has decreased in number and in size in recent decades as sea ice and access to prey decline (Rode, Amstrup and Regehr, 2010; Bromaghin et al., 2014). The Bering/Chukchi Seas population of polar bears has not shown a decline in body condition, size or recruitment to date (Rode et al., 2014). These differences may be attributed to differences in prey and sea ice availability between the southern Beaufort and Chukchi Seas. However, as sea ice decline continues (especially if populations of ice-dependent pinnipeds, the primary prey of polar bears, decline as anticipated), Chukchi Sea polar bear populations would also decline (Amstrup, Marcot, and Douglas, 2007).

Currently, the greatest challenge for polar bear populations world-wide are warming temperatures and sea ice loss due to climate change. As such critical habitat for the polar bear has been designated. CBS bears have not yet been impacted by sea ice loss to the extent that other populations, such as the SBS population have been. It has been predicted that climate change with the resulting warming temperatures and loss of sea ice would lead to polar bears being extirpated from the divergent ice areas within 75 years. The southern Beaufort and Chukchi Seas are part of the divergent ecoregion (Amstrup, Marcot, and Douglas, 2007). To date, impacts on polar bear populations from the oil and gas industry have been limited primarily to disturbance in the Beaufort Sea and adjacent shoreline. Increases in shipping, research, village bear viewing tourism, ship-based tourism, and icebreaker activities may all increase human-bear interactions, resulting in increases in disturbance and potential injuries to bears. These impacts are more pronounced on the Beaufort Sea shoreline rather than the Alaskan Chukchi Sea shoreline. Continued sea ice loss may result in CBS bears onshore spending more time searching for food near villages in Chukotka which may increase the numbers of bears taken in defense of human life. The Proposed Action could add to other sources of human-bear interactions, primarily existing industry, bear viewing tourism, and human-bear interactions in and near villages.

The primary concern for polar bear critical habitat in the Proposed Action Area is loss of sea ice. The USFWS identified three areas or units as critical habitats that require special management or protection: barrier island habitat, sea ice habitat and terrestrial denning habitat. While other stressors

are managed, they are not currently thought to be significant threats to polar bear critical habitat; however, each could become more significant in combination with future effects of climate change and the resultant loss of sea ice critical habitat.

Bearded Seal

Increasing sea ice losses during the summer in the Arctic Ocean are expected to have detrimental effects on bearded seals. While most bearded seals whelp in the Bering Sea, some remain in the Beaufort and Chukchi Seas throughout the year. Whelping conditions for resident bearded seals could temporarily improve with larger lead and polynya systems offering greater access to water and an increase in the sea ice edge effect in those areas. In the Bering Sea where most bearded seals whelp, sea ice would continue to form, though likely to areas farther north than presently occurs, and those bearded seals should continue to successfully reproduce. During the open water season, bearded seals spend most of their time in the water feeding, and would haul out onshore in some areas where haulout locations meet their needs. Considering the behavior of bearded seals in the Sea of Okhotsk, the use of islands and onshore haulouts by bearded seals is likely to increase into the future as sea ice disappears, providing such areas remain undisturbed.

Bearded seals are predominately benthic feeders, and decreases in benthic food stocks could affect the Beringian Distinct Population Segment of bearded seals. Bearded seals feed on benthos, and larger fish stocks may be less favorable for them; however, they frequently feed on fish when the opportunity arises, and some decreases of benthic food resources may not produce severe impacts to this species. If there is an increase in other piscivorous species (i.e. spotted and ribbon seals) or whales (i.e. fin, humpback and minke whales) or an influx of immigrant species (i.e. harbor, harp, hooded or gray seals, or Steller sea lions, etc.) then there could be a rise in interspecies competition that may be detrimental to bearded seals. In the long-term, ocean acidification could result in a net loss of the food base for bearded seals. Such effects are unlikely to occur in the near future; however, with the expected losses among marine micro-biota the entire marine food web would undergo some level of change from its current state, which could be very harmful to bearded seals. For these reasons, climate change effects in the Chukchi and Beaufort Seas are likely to have a greater and more profound impact on bearded seal numbers, distribution, and population viability than all of the past, present, and foreseeable Beaufort Sea area human activities combined.

Sea ice losses during the summer in the Arctic Ocean would also permit increasing numbers of commercial, tourism, and scientific vessel activity. As the Northwest Passage and Northern Sea Route remain clear of ice for longer periods of time, more vessels would likely travel through the Arctic. Growing numbers of commercial vessels could increase boat strikes and would introduce more sound into the marine environment. Seals have been wounded or killed by ducted propeller systems on oceangoing vessels in the North Atlantic and though the potential exists for similar accidents to occur in the Chukchi and Beaufort Sea, seals are agile in the water and easily avoid vessel strikes under normal conditions. The numbers of scientific and industry survey vessels (and associated noise) in the U.S. Beaufort Sea is also likely to increase. Because an increase in military and USCG activity in the U.S. Beaufort Seas is anticipated, U.S. Navy and USCG vessel presence is also likely to increase.

Commercial, military, and scientific aircraft operations are expected to increase into the foreseeable future. Greater use of military jets and helicopters would introduce more noise, though military aircraft typically maintain an altitude of several thousand feet above the water or land surface, which minimizes the disturbance to the marine environment. Scientific surveys using aircraft such as the ASAMM, BOWFEST, BWASP, etc. fly at altitudes sufficient to negate most transfer of sound into the water. Aircraft have little effect on bearded seals when they are in the water; however, hauled out bearded seals may display flight reactions if approached too closely by low-flying aircraft. Most flight reactions consist of quickly slipping into the water.

Climate change effects to the Chukchi and Beaufort Seas would most likely have mixed effects on bearded seals; one that is expected to be greater than all of the past, present, and foreseeable direct human activities combined. In the near term, bearded seals would enjoy larger lead systems and polynya systems, which may support larger numbers of bearded seals. Likewise, the increased productivity in the Arctic Ocean from increased terrestrial inputs and longer ice-free seasons could better support bearded seals, at least into the near future. In the long-term, climate change effects are expected to eliminate summer sea ice, and possibly wreak havoc on many species of marine fauna, including some species that are crucial to the existing food web. The effects of the Proposed Action on bearded seals would not appreciably add to, subtract from, or synergistically interact with other past, present, or reasonably foreseeable future activities, or climate change, to alter the condition of bearded seals in the Arctic during the 21st century.

Ringed Seal

Sea ice losses during the summer in the Arctic Ocean are expected to have detrimental effects on ringed seals. As sea ice melts, ice-based whelping, basking, and resting habitat would be depleted, and could eventually disappear. Though sea ice is necessary for birthing lairs and whelping, in other parts of the species range, terrestrial haulouts are used if sea ice is absent. Most ringed seals whelp in the Bering Sea; however, many remain in the Beaufort and Chukchi Seas throughout the year. Whelping conditions for resident ringed seals are expected to degrade with increasing rain-on-snow events compromising the integrity of subnivean ringed seal birthing dens. In the Bering Sea where some ringed seals whelp, sea ice would continue forming in the fall, though the maximum ice extent may end farther north than it does now. During the open water season, ringed seals spend most of their time in the water feeding, and have been known to haul out onshore in some areas where haulout locations meet their needs, such as portions of Hudson Bay, Canada. Considering the behavior of ringed seals in the Sea of Okhotsk, the Baltic Sea, and inland lakes of Scandinavia, the use of islands and onshore haulouts by ringed seals may increase into the future as sea ice disappears, providing such areas remain undisturbed.

Ringed seals feed on fish, and the expected increases in pelagic fish and invertebrate production may be a positive effect of climate change on ringed seals. An increase in the numbers of other piscivorous species (i.e. spotted and ribbon seals) or whales (i.e. fin, humpback, and minke whales), and/or an influx of immigrant species (i.e. harbor, harp, hooded, or gray seals, or Steller sea lions, etc.) could, however, lead to a rise in competition that may be detrimental to ringed seals. Climate change effects in the Chukchi and Beaufort Seas are likely to have greater impact on ringed seal numbers, distribution, and population viability than all of the past, present, and foreseeable human activities combined.

Effects of increasing aircraft traffic on ringed seals are similar to those described above for bearded seals; aircraft operations would have negligible effects on ringed seals.

Climate change effects to the Chukchi and Beaufort Seas would most likely have some positive, and some negative effects on ringed seals; greater and more profound than all of the past, present, and foreseeable human activities combined. The effects of the Proposed Action on ringed seals would not appreciably add to, subtract from, or synergistically interact with other past, present, or reasonably foreseeable future activities, or climate change, to alter the condition of ringed seals in the Arctic Sea during 21st century.

Spotted Seal

Sea ice losses in the Arctic Ocean should not have detrimental effects on spotted seals, which readily haul out on islands, mudbars, and other coastal areas. Spotted seals are predominately pelagic feeders, feeding on fishes and invertebrates in the water column. In the Bering Sea, where most spotted seals whelp, sea ice would continue to form, though likely to areas farther north than presently occurs.

Those spotted seals should continue to successfully reproduce and whelping conditions should not change significantly. During the open water season, spotted seals spend most of their time in the water feeding, and considering their behavior in the Sea of Okhotsk, Bering Sea, and Yellow Sea, the use of islands and onshore haulouts by spotted seals is likely to increase into the future as sea ice disappears, providing such areas remain undisturbed.

Spotted seals feed on fish, so large stocks of fish would favor them. Consequently, the expected increases in pelagic fish and invertebrate production should be a positive effect of climate change on spotted seals. If numerical increases of other piscivorous seals (i.e., spotted and ribbon seals) or whales (i.e., fin, humpback, and minke whales) and/or an influx of immigrant species (i.e., harbor, harp, hooded, or gray seals, or Steller sea lions, etc.) occurs, a rise in interspecific competition might also occur which could be detrimental to spotted seals. Climate change effects in the U.S. Beaufort Sea are likely to have a positive effect on spotted seals that is greater and more profound with respect to impacts on spotted seal numbers, distribution, and population viability, than all Beaufort Sea past, present, and foreseeable human activities combined.

Effects of increasing aircraft traffic on spotted seals are similar to those described above for bearded seals; aircraft operations would have negligible effects on spotted seals.

Climate change effects to the Chukchi and Beaufort Seas would have a positive effect on spotted seals; one that is expected to be greater than all of the past, present, and foreseeable human activities combined.

The effects of the Proposed Action on spotted seals would not appreciably add to, subtract from, or synergistically interact with other past, present, or reasonably foreseeable future activities, or climate change, to alter the condition of spotted seals in the Chukchi Sea during the 21st century.

5.2.6.4. Conclusion

Beluga Whale

Though vessel traffic and/or a large spill event could have moderate effects on belugas, such effects would be short-term with no long-term lingering effects on the species. By comparison, the effects of climate change would be negligible to minor at any given time, yet have major or even catastrophic long-term effects on this species. The greatest human activities and effectors on beluga whales would be anthropogenic climate change, followed by subsistence hunting, and commercial vessel traffic. Other activities are either too limited in their effects to produce noticeable impacts on belugas, or lack overlap with beluga whale life cycles and requirements.

While the contribution of the Proposed Action to effects on beluga whales would be negligible, the anticipated cumulative effects of past, present and reasonably foreseeable future activities would represent a major level of effects due to the effects of climate change.

Bowhead Whale

Though vessel traffic and/or a large spill event could have moderate effects on bowhead whales, such effects would be short-term with no long-term lingering effects on the species. In comparison, the effects of climate change would be negligible to minor at any given time, yet have major or even catastrophic long-term effects on this species. The greatest human activities and effectors on bowhead whales would be anthropogenic climate change, followed by subsistence hunting, and commercial vessel traffic. Other activities are either too limited in their effects to produce noticeable impacts on bowheads, or lack overlap with bowhead whale life cycles and requirements. While the contribution of the Proposed Action to effects on bowhead whales would be negligible, the anticipated cumulative effects of past, present and reasonably foreseeable future activities would represent a major level of effects due to the effects of climate change.

Gray Whale

Though vessel traffic and/or a large spill event could have moderate effects on gray whales, such effects would be short-term with no long-term lingering effects on the species. In comparison the effects of climate change would be negligible to minor at any given time, yet have major long-term effects on this species. The greatest human activities and effectors on gray whales would be anthropogenic climate change, followed by subsistence hunting, and commercial vessel traffic. Other activities are too limited in their effects to produce noticeable impacts on gray whales, or lack overlap with gray whale life cycles and requirements. While the contribution of the Proposed Action to effects on gray whales would be negligible, the anticipated cumulative effects of past, present and reasonably foreseeable future activities would represent a major level of effects due to the effects of climate change.

Pacific Walrus

As stated above, the USFWS considers Pacific walrus to be extralimital to the Proposed Action Area. The Proposed Action would have negligible impacts on Pacific walruses. The effects of climate change, however, would be negligible to moderate at any given time, and have major or even catastrophic long-term effects on this species. The greatest human activities and effectors on Pacific walruses would be anthropogenic climate change, followed by vessel traffic, and subsistence harvest. Other activities are too limited in their effects to produce noticeable impacts on walrus, or lack overlap with Pacific walrus life cycles and requirements. While the contribution of the Proposed Action to effects on Pacific walruses would be negligible, the anticipated cumulative effects of past, present and reasonably foreseeable future activities would represent a major level of effects due to the effects of climate change.

Polar Bear

Although Proposed Action activities could have minor to moderate effects on polar bears, most effects would be short-term with no long-term lingering effects on the species, and could be reduced with use of mitigation. The greatest human activities and effectors on polar bears would be anthropogenic climate change, followed by human-bear interactions. Other activities are too limited in their effects to produce noticeable impacts on polar bears, or lack overlap with polar bear life cycles and requirements. While the contribution of the Proposed Action to effects on polar bears would be minor to moderate at most, the anticipated cumulative effects of past, present and reasonably foreseeable future activities would represent a major level of effects due to the effects of climate change.

Bearded, Ringed and Spotted Seals

Though vessel traffic and/or a large spill event associated with the Proposed Action could have moderate effects on bearded, ringed, and spotted seals, such effects would be short-term with no long-term lingering effects on the species. The effects of climate change would be negligible to minor at any given time, yet have major or even catastrophic long-term effects on this species. The greatest human activities and effectors on bearded, ringed, and spotted seals would be anthropogenic climate change and subsistence hunting. Other activities are either too limited in their effects to produce noticeable impacts on bearded, ringed, and spotted seals, or lack overlap with seal life cycles and requirements. While the contribution of the Proposed Action to effects on bearded seals, ringed seals, and spotted seals would be negligible, the anticipated cumulative effects of past, present and reasonable foreseeable future activities would represent a major level of effects due to the effects of climate change.

5.2.7. Terrestrial Mammals

Summary of Impacts

The level of effects of the Proposed Action on several key species were analyzed in Chapter 4 of this document and are summarized as follows: caribou – major; muskox – minor; grizzly bear – negligible; Arctic fox – major

Activities associated with the Proposed Action that could impact terrestrial mammals include physical presence and noise from:

- Helicopters
- Onshore facilities
- Vehicle and equipment operations
- Pipeline construction

The greatest effects to terrestrial mammals, particularly caribou, would arise from aircraft, vehicle, and equipment operations during facility and pipeline construction that could induce injurious escape reactions among caribou, especially caribou herds and individuals with young.

The Proposed Action could also impact terrestrial mammals through habitat alteration that could persist for years or decades. Potential spill events could also result in long term impacts to terrestrial mammals.

5.2.7.1. Discussion of Other Relevant Actions

Oil and Gas Activities: Oil and gas exploration has occurred on the North Slope since the early 1900s. Development and production near Prudhoe Bay commenced in the early 1970s and continues today. The TAPS, built in 1977, continues to convey produced oil southward from Prudhoe Bay-area developments to Valdez along the southern Alaskan coast. More recently, exploration has occurred on the Beaufort Sea OCS and Chukchi Sea and in onshore areas within the NPR-A.

In addition to exploration and field development, the State of Alaska and industry are investigating the feasibility of constructing a natural gas pipeline from Prudhoe Bay to south-central Alaska with possible spurs to support communities near the pipeline route.

Concurrent with recent oil and gas exploration and development activities in the U.S., both Canada and Russia are engaged in offshore exploration and development projects in the eastern Beaufort and Siberian Seas, respectively. In preparation for future oil and gas activities, Russia has been actively upgrading and creating support infrastructure along their Arctic coastline. Gearon et al. (2014) modelled the spread of spills originating in the Eastern Beaufort Sea, and found oil from a theoretical 5.4 million bbl loss of well control could contact some Beaufort and Chukchi Sea nearshore areas. Such events would be highly unlikely considering geology, reservoir sizes, water depths, and pressures involved with Arctic wells, however.

Economic Development: The effects of economic development could include increased financial resources for subsistence hunters, which could result in the ability to purchase more fuel and higher quality equipment for subsistence activities, which could result in greater subsistence harvest success. In the long term, harvests of some terrestrial mammal species should decline in tandem with the climate change effects on Arctic fox and caribou populations; however, harvests of other species such as moose, grizzly bears, muskoxen, Dall sheep, and some furbearing species could increase if those populations shift north or increase in response to habitat changes.

Recreation and Tourism: The opening of Arctic waterways connecting the Beaufort Sea with the western Atlantic Ocean and the Chukchi Sea with eastern Atlantic Ocean has allowed a tourism industry to develop in recent years. Tourism is expected to increase in the future. Such tours involve

cruise ships which produce noise and discharges, as well as onshore activities including sport hunting and fishing, wildlife viewing, photography, and adventure activities. Sport hunting and fishing could produce moderate effects on some wildlife and fish populations since individuals are harvested, but population level effects are not anticipated. In comparison, activities such as wildlife viewing, and adventuring do not typically impact wildlife population. The overall effects of recreation and tourism on terrestrial mammals are expected to be moderate due to mortalities associated with recreational hunting and fishing.

Aircraft Traffic. Aircraft use on the North Slope is typically performed by oil and gas exploration companies, and by government entities who conduct surveys such as ASSAM, and BOWFEST. Aircraft traffic between communities, camps, and infrastructure developments could increase as oil and gas construction and scientific research continue and possibly increase into the future. Air traffic may have minor to moderate impacts on terrestrial mammals if aircraft altitudes drop below 1,500 feet AGL. Otherwise the level of effects from aircraft on terrestrial mammals should be negligible to minor.

Subsistence. Thousands of caribou are harvested annually in subsistence hunts, along with many other species of mammals including moose, muskox, grizzly bear, Dall sheep, marmots, hares, and various furbearing animals. The numbers of animals harvested vary by community and hunting areas, which typically extend for many miles around each community. For this reason each community has a unique subsistence area with no two being identical in proportions.

Mining. The Red Dog mine is located in the western Brooks Range near the Chukchi Sea coast, and is the world's largest zinc mine. Other mineral mines (e.g., Donlin Gold) are proposed for western Alaska, none of which occur near the LDPI. Barring unforeseeable accidents, it is unlikely mining itself would have any identifiable effects on terrestrial mammals; however, road creation and the vehicular, air, and vessel traffic associated with such mines would produce negligible to moderate levels of effects due to impacts on individual animals.

Climate Change. Climate change in the Arctic is the driving factor behind increasing vessel traffic, air traffic, military activity, and economic development. It is also expected to have the greatest effects on terrestrial mammals in the Arctic. The effects of climate change on terrestrial mammals include primary and secondary changes to ecological processes that mammalian species depend on for life. Some such changes could be beneficial to certain species and detrimental to others, depending on which life processes are affected for a species and the manner in which those effects occur.

Collectively, these effects of climate change could affect every living organism in the marine, coastal, and terrestrial environment of Alaska. Increasing warmth could lead to increased sea ice losses, increased glacial ice melt, earlier and faster snowmelt, extended growing seasons, increased precipitation, and shortened winters. Air and water temperatures in both summer and winter would increase. Soil moisture levels could change, becoming dryer in some areas and more hydrated in others, resulting in erosion and release of soil constituents such as CO₂ (Natali et al., 2014), nitrogen, and methane into the atmosphere. In recent years, holes as large as 30 m (98 ft) wide by 70 m (230 ft) deep have appeared in northern Siberia where the permafrost melted, along with methane hydrates sequestered in the soil (Moskvitch, 2014).

Melting permafrost can also create melt ponds and lakes on tundra in low lying areas. Such catchments of soil moisture are unlikely to directly flow into streams and may be ephemeral. Rivers and streams along the ACP would also experience impacts from changes to the climate with earlier episodes of spring flooding (Nghiem et al., 2014; Beltaos, 2013; Queenie et al., 2012) followed by decreases in groundwater inputs derived from melting snow, ice, and permafrost (Qiu, 2012). Spring and summer flooding of river systems can lead to large influxes of warmer freshwater into the Arctic marine environment. If such events occur in a rapid surge as opposed to a steady inflow, extensive areas of sea ice could melt rapidly (Nghiem et al., 2014).

Sea ice losses in the Arctic Ocean may lead to larger storms, resulting in larger waves that can rapidly erode coastlines and islands (Vavrus, 2013). Such events would permit larger and more frequent storm surges to reach farther inland from the coast. Storms and storm surges, along with warming air, would facilitate the thawing of permafrost in Arctic soils, increasing the annual depth of thawed soils (Kittel, Baker, Higgins, and Haney, 2011; Vavrus, 2013), and leading to the release of soil organic matter into watersheds. Nearshore areas of the Beaufort and Chukchi Seas would receive larger fluxes of organic materials from eroding coastlines, streambanks, and from the thawing permafrost that would add to the organic constituents of the marine food web while removing them from the terrestrial system.

Ocean acidification would continue to occur as a result of climate change, and would decrease the availability of calcium carbonate that invertebrates use for shell development. Under such conditions creatures such as bivalves, pteropods, and polychaete worms would have difficulty creating and maintaining shells while other species such as jellies, sea urchins, and brittle stars that do not have calcium carbonate exoskeletons might flourish.

At the microbial level, blue-green algae could have trouble creating the calcium carbonate matrices needed to permit them to remain near the surface of the ocean, which could have severe repercussions throughout the oceanic food web. Anadromous fishes spawn in freshwater streams, often dying afterwards. In doing so, they provide an influx of nutrients from the marine environment to the terrestrial environment. Those nutrients positively affect vegetation growth and production in riparian areas, which provides more nutritious food to caribou, muskoxen, and other herbivores, as well as bears.

Grizzly bears, and Arctic foxes feed on salmon and other fishes if given the opportunity, and in doing so, receive high quality nutrition directly from the ocean. The herbivores feeding on riparian vegetation are often eaten by predators such as grizzly bears and Arctic foxes.

Both summer and winter temperatures are expected to increase across the North Slope through this century, with the greatest changes occurring in winter. Average winter temperatures are likely to increase by as much as 12.6°F (7°C) by the 2040s, while summer temperatures are projected to rise by about 5.4°F (3°C) by the 2040s (Scenarios Network for Alaska and Arctic Planning, updated using SNAP tool <https://www.snap.uaf.edu/> accessed April, 2017). Precipitation patterns are also expected to change with 20-45% increased winter precipitation by the 2040s; while summer precipitation increases would be smaller. A northward shift in thaw dates is expected over the course of the century with thawing occurring in the coastal regions during the first week of June by mid-century and June 1 by the end of the century; while thaws would occur around May 1st in the southern NPR-A. In comparison, fall freeze-up dates along coastal areas would extend into late September, and October 1st in the Brooks Range. Consequently growing seasons could grow by another 6 weeks in the northern portions of the ACP, and by 3 weeks in the mountains of the Brooks Range (Scenarios Network for Alaska and Arctic Planning, 2011). Most of the western ACP is expected to remain within the existing temperature and precipitation ranges; but by century's end, conditions in the southern areas of the ACP (Brooks Mountains) would better match those presently found in warmer areas of Alaska. These climatic changes would lead to alterations in the vegetative communities which could have a profound impact on terrestrial mammals and productivity in the area.

Such impacts could include incursions of shrubs and trees in to areas that were formerly tundra-dominated; the replacement of existing ecological communities with new and novel ones; the arise of new ecosystems; the introduction of new diseases into the region, and the appearance of new mammal species, loss of existing mammal species, and range shifts for others.

5.2.7.2. Analysis of Cumulative Impacts

Caribou

In recent years, shrubs and trees have been observed growing in places where they previously did not exist; the potential for shrub and tree encroachment into the Arctic has become a cause for concern (McNew et al., 2013). The successful development of new plant communities, and the northward advance of trees and shrubs would depend on the genetically regulated abilities of a species to adapt to new environmental conditions (Nicotra et al., 2010; Shaw and Etterson, 2012; Franks and Hoffmann, 2012). Consequently there may be genetic limitations to how far north a plant species can grow, an environmental limitation other than temperature and precipitation; meaning trees and shrubs in northern Alaska may lack the genetic flexibility necessary to germinate and grow along the Chukchi and Beaufort Sea coastlines or on the ACP.

Kaarlejärvi (2014) determined herbivores such as reindeer (caribou), and microtines can prevent lowland forbs from invading areas of open tundra through herbivory counteract the effects of climate warming by slowing or preventing the invasion of new plant species into tundra systems. Cahoon et al. (2012) determined large herbivores can mediate the responses of Arctic ecosystems to climate change through herbivory. Thus, maintaining healthy populations of caribou and other large herbivores in the Arctic may offset many of the ecological effects of climate change such as shifts in diversity, invasion by novel new species, and transitions to novel new ecological communities.

An effect of longer, warmer growing seasons with a deeper layer of thawed permafrost is increased root production by vascular plants. A shift to earlier emergence of plants could potentially lead to a trophic-mismatch between plant development, nutritional quality of plants, and caribou calving and grazing (Kerby and Post, 2013). Increases in growing season length, temperatures, permafrost thawing, and increased precipitation could be advantageous to the production of vascular forage plants on summer ranges. However, the increase in vascular range plants would result in a corresponding loss to non-vascular winter range plants such as lichens, which could be detrimental to caribou.

Caribou can be affected by the loss of sea ice in the Arctic. Without ice to moderate the effects of wind on the ocean's surface, larger storm events which could destroy extensive areas of coastal habitat over time could occur throughout the Beaufort Sea.

Increasing fire frequency is another characteristic of climate change in the Arctic and could lead to long-term destruction of caribou winter ranges; some areas may take 50 years or more to recover from fires (Joly, Duffy, and Rupp, 2012; Gustine et al., 2014).

Recently, the topic of winter rain-on-snow event degradation of caribou winter ranges has been discussed. Little empirical evidence supports such a view, and Tyler (2010) concluded the effects of climate variability on caribou are "dwarfed" by the effects of density-independent factors of politics, social issues, and economics. Since 2010 other studies have been conducted which support the assumption of adverse effects from rain-on-snow events (Descamps et al., 2017; Langolis et al., 2017; Hansen et al., 2011; Hansen et al., 2014).

Changes in local economics within Arctic communities are likely to have some effects to caribou into the future. Increased financial resources would allow subsistence users to remain in the field longer, purchase better equipment, and improve their hunting success; however, increased financial resources would also allow communities to purchase more non-subsistence foods, thus potentially decreasing subsistence activity.

Recreational hunting of caribou from the Western Arctic (Caribou) Herd (WAH) is likely to decrease in response to a dwindling herd size. Military and USCG operations on the ACP may have some minor effects on caribou due to elevated levels of aircraft traffic which could be deleterious to caribou

until they habituate to aircraft noise and presence (Wolfe, Griffith, and Wolfe, 2000). Other sources of aircraft traffic that could affect caribou include more commercial flights into and out of North Slope communities, and flights supporting future industrial developments that are unrelated to the Proposed Action. Increasing numbers of vehicles, roads and pipelines in association with onshore oil and gas developments are anticipated, as are the construction of infrastructure and facilities to support onshore oil and gas operations.

Climate change across the North Slope would have mixed effects on caribou; effects that are expected to be greater than all of the North Slope past, present, and foreseeable human activities combined. The effects of the Proposed Action on caribou would be negligible and would not appreciably add to, subtract from, or synergistically interact with the major level of effects from climate change or the minor to moderate effects of other past, present, or reasonably foreseeable future activities on caribou of the WAH, the Teshekpuk Lake Caribou Herd, and the Central Arctic Caribou Herd during the 21st century.

Muskox

Muskox can be affected by the loss of sea ice in the Arctic. As sea ice losses continue to increase, larger storms may occur throughout the Arctic Ocean, and without sea ice to moderate the effects of winds on water, large waves and swells develop which could impact coastal habitat over time. Increases in growing season length, temperatures, permafrost thawing, and increased precipitation could be advantageous to the production of vascular forage plants on summer ranges, which would be a positive effect for muskoxen. An effect of longer, warmer growing seasons with a deeper layer of thawed permafrost is increased root production by vascular plants, and a shift to earlier emergence of plants that could lead to a trophic-mismatch between plant development, nutritional quality of plants, and muskox calving and grazing, as Kerby and Post (2013) observed for caribou. However, the non-migratory behavior of muskoxen may prevent trophic-mismatches between muskox and their forage species. Increasing fire frequency could lead to the long-term destruction of musk ox winter ranges; however, seral (intermediate) stages that follow Arctic wildfires would include graminoid, forb, and shrub communities that could favor muskoxen.

Changes in long term flora on the North Slope could affect Arctic herbivores. In recent years, shrubs and trees have been observed in places where they previously did not grow. The potential for shrub and tree encroachment into the Arctic has been a cause for concern (McNew et al., 2013); however, the development of new plant communities, and the northward advance of trees and shrubs would depend on genetically regulated abilities of each species to adapt to new environmental conditions (Nicotra et al., 2010; Shaw and Etterson, 2012; Franks and Hoffmann, 2012). Consequently, genetic limitations may limit how far north a plant species can grow; meaning trees and shrubs in northern Alaska may lack the genetic flexibility necessary to germinate and grow along the Chukchi and Beaufort Sea coastlines, or on the ACP. With a mixture of habitat, muskoxen would ideally graze sedge meadows on the ACP in summer, and use shrublands during winter for cover and browse from time-to-time.

Kaarlejärvi (2014) determined mammalian herbivores can prevent lowland forbs from invading areas of open tundra through herbivory, and that herbivores counteract the effects of climate warming by slowing or preventing the invasion of new plant species into tundra systems. Cahoon et al. (2012) determined large herbivores can mediate the responses of Arctic ecosystems to climate change through herbivory. Thus maintaining healthy populations of muskoxen, and other large herbivores in the Arctic may offset many of the ecological effects of climate change such as shifts in diversity, invasion by novel new species, transitions to novel new ecological communities, etc. Under the current climate change projections muskoxen numbers may actually increase along the North Slope.

Recently, winter rain-on-snow event degradation of caribou winter ranges has been discussed; however, muskoxen rely on stored reserves during much of the winter and generally do not browse or

graze extensively. Consequently, the effects of icing on muskox winter habitat would likely be negligible, and since muskoxen prefer “shrubby” habitat that is increasing in some areas of Arctic Alaska, some positive effects to muskoxen may occur through the creation of new habitat.

Changes in local economics within Arctic communities are likely to have some effects to muskox into the future. Increased financial resources would allow subsistence users to remain in the field longer, purchase better equipment, and improve their hunting success; however, increased financial resources would also allow communities to purchase more non-subsistence foods that could remove some dependency on subsistence foods, which could result in a smaller subsistence harvest on muskoxen. Recreational use of muskox may increase or decrease in response to fluctuations in the numbers of muskoxen, and the increasing costs involved with accessing the animals for sport hunting. Furthermore, military and USCG operations on the ACP may have some minor effects on muskox. The primary impact from onshore military and USCG operations would be elevated levels of aircraft traffic which may negatively affect muskox until they habituate to aircraft noise and presence.

Other sources of aircraft traffic that could affect muskox include more commercial flights into and out of North Slope communities and flights supporting future industrial developments that are unrelated to the Proposed Action. Increasing numbers of vehicles, roads and pipelines in association with onshore oil and gas developments are anticipated, as are the construction of infrastructure and facilities to support onshore oil and gas operations.

Climate change effects across the North Slope would have a mixed effect on muskoxen; effects that are expected to be greater and more profound than all of the past, present, and foreseeable human activities combined. The effects of the Proposed Action on muskox would be negligible and would not appreciably add to, subtract from, or synergistically interact with other past, present, or reasonably foreseeable future activities, or climate change, to alter the condition of muskox during the 21st century, which in total represent minor impacts.

Grizzly Bear

Grizzly bears can be affected by climate change in the Arctic. As sea ice losses continue to increase larger storm events may occur throughout the Arctic Ocean. Without sea ice to moderate the effects of winds on water, large waves and swells would develop which could impact coastal habitat over time. Such storms are more likely to deposit marine mammal carcasses and other food resources onshore that would have a positive effect on grizzlies scavenging carrion.

Increases in growing season length, temperatures, permafrost thawing, and increased precipitation could be advantageous to the production of vascular forage plants on summer ranges, which would be a positive effect for grizzlies. One effect of longer, warmer growing seasons with a deeper layer of thawed permafrost is increased root production which leads to shifts from non-vascular plants to vascular plants, and a shift to earlier plant emergence that could become an important source for grizzly bears emerging from hibernation. Increasing fire frequency could lead to the conversion of moss and lichen-dominated ecological communities, to graminoid and forb-dominated ecological communities.

Changes in long term flora on the North Slope could affect prey species such as Arctic ground squirrels, muskox, moose, and caribou. Grizzlies would respond to the probable future fluctuations in prey species numbers by switching to other food sources such as salmon. They may also shorten their denning period in response to climate change effects to the duration and severity of winter. Under the current climate change projections, grizzly numbers could increase throughout the North Slope, providing they have access to sufficient numbers of prey animals and forage plants.

The changes in local subsistence economies described above in the caribou and muskox sections would also likely result in a smaller subsistence harvest of grizzly bears.

Recreational hunting of grizzly may increase or decrease in response to grizzly population fluctuations. Military and USCG operations on the ACP may have some minor effects on grizzly bears due to elevated levels of aircraft traffic. Other sources of aircraft traffic that could affect grizzlies would include more commercial flights into and out of North Slope communities, and flights supporting future industrial developments. Increasing numbers of vehicles, roads, and pipelines in association with onshore oil and gas developments are anticipated, as are the construction of infrastructure and facilities to support onshore oil and gas operations.

Climate change effects across the North Slope would have a mixed impact on grizzly bears and these impacts are expected to be greater than all of the other past, present, and foreseeable human activities combined. The effects of the Proposed Action on grizzlies would be negligible and would not appreciably add to, subtract from, or synergistically interact with the minor, but positive, climate change effects, and other negligible effects from past, present, or reasonably foreseeable future activities on North Slope grizzly bears during 21st century.

Arctic Foxes

Furbearing mammals such as wolves, wolverines, Arctic foxes, red foxes, and lynx can be affected by climate change in the Arctic. Larger storms coming off the ocean are more likely to deposit marine mammal carcasses and other food resources onshore, which would be a positive effect for furbearers that scavenge carrion. Another positive benefit of climate change on furbearers would be the increased biological productivity that a warming climate would have throughout the terrestrial plant communities. Such productivity would initially include increased plant vegetative production, which in turn would provide increased forage for herbivores. Healthier and more abundant prey species, or new prey species, would then have beneficial effect on furbearing mammals such as foxes, wolves, wolverines, etc., through a more diverse and reliable diet. For example, a decrease in caribou numbers might be compensated for by increases in rodent, muskox, moose, or sheep numbers due to better range conditions and milder temperatures. For furbearers, having a resident population of prey species in addition to migratory caribou could mean consistent, high-quality nutrition throughout the year, rather than hunger interspersed with periodic episodes of feasting when caribou calve or migrate through an area, or when carrion becomes available.

Changes in local economics within Arctic communities are likely to have some effects to furbearers into the future. Increased financial resources would allow subsistence users and trappers to remain longer in the field, procure better equipment, and improve their trapping success. For trappers, this would then increase revenues within households.

Military and USCG operations on the ACP may have some minor effects on furbearers due to elevated traffic, though wolves, wolverines, and foxes can habituate to aircraft noise and presence (Manci et al., 1988; Churchill and Holland, 2003). Increasing numbers of vehicles, roads, and pipelines and other infrastructure in association with onshore oil and gas developments are anticipated. As with military infrastructure, developments such as buildings, berms, and other modifications to the landscape could provide foxes with new denning areas, which would have a positive effect on fox populations.

Climate change effects across the North Slope would have a positive impact on most furbearing mammals; effects that are expected to be greater than all of the past, present, and foreseeable local human activities combined. Increases in red fox numbers would likely result in lower numbers of Arctic foxes since red foxes predate and out-compete Arctic foxes in most areas where these species coexist. The effects of the Proposed Action on all furbearers would be negligible and would not appreciably add to, subtract from, or synergistically interact with other past, present, or reasonably foreseeable future activities, or climate change, to alter the condition of furbearers during 21st century.

5.2.7.3. Conclusion

Caribou

The effects of climate change on caribou populations would likely lead to a decrease in herd sizes over the 21st century due to winter habitat losses, limited shrubland expansion onto the North Slope, and conversions of non-vascular and wetland plant communities to graminoid/forb-dominated communities. Retaining large herbivores on the landscape may mitigate some level of shrubland expansion; however, these changes are expected and, collectively, would have a major level of effect on caribou. The human activities that are expected to occur should have a negligible level of effects on caribou. While the contribution of the Proposed Action to effects on caribou of the CAH would be negligible, the anticipated cumulative effects of past, present and reasonable foreseeable future activities would represent a major level of effects due to the effects of climate change.

Muskox

The effects of climate change on muskox populations could lead to stable or increasing herd sizes over the 21st century due to longer growing season, limited shrubland expansion onto the North Slope, and conversions of non-vascular and wetland plant communities to graminoid/forb-dominated communities which would provide more forage. The human activities that are expected to occur should have negligible levels of effect on muskox, while the Proposed Action would contribute a negligible level of effect. The cumulative effects of past, present, reasonably foreseeable activities, and the Proposed Action would amount to a minor level of effects on muskox.

Grizzly Bear

Climate change would have minor, positive impacts on grizzly populations. Effects would likely include slight population increases over the 21st century due to improved biological productivity and the potential for larger, and more numerous Arctic ground squirrels, larger salmon runs, increased marine mammal carrion, etc. The human activities that are expected to occur would result in a negligible level of effect on grizzly populations, as would the Proposed Action. The contribution of the Proposed Action to cumulative effects of past, present, reasonably foreseeable activities, and climate change, amount to a minor level of beneficial effects on grizzly bears on the ACP and North Slope of Alaska.

Arctic Foxes

Climate change would have a moderate to major level of effects on Arctic foxes on Alaska's North Slope. Effects would likely include population reductions over the 21st century due to increased competition with red foxes, changes in biological diversity, and changes to sea ice characteristics that would restrict the extent and duration of scavenging on sea ice, etc. The Proposed Action should have a negligible level of effect on Arctic foxes. The contribution of the Proposed Action effects to the cumulative effects of past, present, reasonably foreseeable activities, and climate change, would amount to a major level of effects on Arctic foxes, due to climate change effects on habitat.

5.2.8. Vegetation and Wetlands

5.2.8.1. Summary of Impacts

The impacts of the Proposed Action on vegetation and wetlands in the area of the Proposed Action include: destruction of a small amount of vegetation and wetlands during construction of gravel pads, excavation of the 21 acre gravel mine site, construction of Vertical Support Members Construction, use of ice roads and pads, potential for colonization by non-native, invasive species, and accidental small or large oil spills. These impacts result in a complete loss of the functional value of approximately 26 acres of wetlands for the Proposed Action. Given the limited extent of these impacts, the amount of undisturbed wetlands and vegetation in the onshore areas surrounding the

Proposed Action, and the pristine condition of these wetlands and vegetation, the overall impacts are expected to be minor to moderate.

5.2.8.2. Discussion of Other Relevant Actions

Past and Present Actions

North Slope vegetation and wetlands have been impacted by human activities, including oil and gas exploration and development. Archaeological and paleontological digs, camps associated with scientific studies, recreational use, overland moves by transport vehicles, and use of off-highway vehicles such as four-wheel vehicles and snowmachines, have likely caused the loss of less than 100 acres of vegetation and wetlands in the NPR-A, according to the BLM (2012). Approximately 2,500 acres on the North Slope (1,800 acres of village and public facilities, and 700 acres of military facilities) have been directly impacted by these actions, and an additional 4,630 acres of wetland are indirectly affected by human activities occurring off gravel roads and pads. This loss of vegetative cover is likely to persist into the indefinite future. Oil and gas infrastructure accounts for the largest past and present impacts to vegetation and wetlands on the North Slope. BLM has estimated that through 2012, the footprint of oil and gas activities on the North Slope (to include roads, pads and oil fields near the Dalton Highway) is approximately 18,150 acres, and the total long-term impacts to wetlands from past and present oil and gas activities on the North Slope covers approximately 36,800 acres.

Reasonably Foreseeable Future Actions

The amount of area on the North Slope that would be disturbed by non-oil and gas activities is projected to increase by about 2% annually, approximately doubling to 3,600 acres by the mid-21st century when the human population may level off (BLM, 2012).

- A continued loss of minor amounts of vegetation would be expected on the North Slope from archaeological and paleontological digs, camps associated with scientific studies, recreational use and other activities, overland moves by transport vehicles, and use of off-highway vehicles such as four-wheel vehicles and snowmachines. In most cases, loss of vegetation would be temporary, lasting only a few years.
- Villages are likely to increase in size, encroaching on vegetation and wetlands.
- Air Force Radar Sites are not likely to expand. Other military facilities, villages, airstrips, and other non-oil and gas infrastructure are likely to persist into the indefinite future.

North Slope oil and gas development activities discussed above would contribute to cumulative effects to vegetation, due to: construction of ice roads, onshore pipelines, pads, roads and airstrips for both onshore and offshore development; gravel mines; dust and moisture regime changes; and invasive species.

- If current rates of development and production continue into the future in the vicinity of the Colville River to the Canning River in the NPR-A, about 3,750 additional acres would be covered by gravel for construction of pads, roads and airstrips and 750 acres would be impacted by gravel mines and through dust and moisture Impacts from ice road, ice pad, and ice airstrip construction in the federally managed NPR-A on Alaska's North Slope would occur on 232,710 to 458,003 acres of vegetation; these would be short-term impacts and would not accumulate (USDOI, BLM, 2012). In total, long-term impacts to vegetation from exploration and development combined would occur on >0.12% to <0.26% of the NPR-A.

5.2.8.3. Analysis of Cumulative Impacts

The total amount of vegetation and wetlands on the North Slope impacted by oil and gas development and other activities is anticipated to increase. The contribution of the Proposed Action to wetland loss,

disturbance, and degradation is negligible but would be additive to the impacts from past, present, and reasonably foreseeable actions. Vegetation and wetland habitat impacted by oil and gas exploration and development is relatively small compared to the amount of available habitat on the ACP in Alaska and on the North Slope as a whole. Impacts on vegetation and wetlands caused by the Proposed Action and other present and future oil activities could accumulate and persist, especially if structures remain after industrial activity has ceased.

5.2.8.4. Conclusion

Impacts to vegetation and wetlands of Alaska's North Slope from the Proposed Action are not expected to add significantly to the impacts associated with other activities. Impacts to the vegetation and wetlands from oil and gas development and other activities are anticipated to continue into the future. Many of these impacts would be permanent, but it is anticipated that some disturbances to vegetated communities would be actively restored. While the cumulative impacts from the Proposed Action and other past, present, and reasonably foreseeable actions are additive, the total amount of disturbance area is small compared to the total amount of wetlands on the ACP. Therefore, the overall contribution of the Proposed Action to cumulative effects to vegetation is negligible. It is anticipated that the environmental changes associated with Arctic climate change would, in the long run, have the greatest potential to impact vegetation and wetlands on the North Slope.

5.2.9. Sociocultural Systems

5.2.9.1. Summary of Impacts

The primary subsistence activity that could be adversely affected by the Proposed Action is bowhead whaling conducted by crews from Nuiqsut near Cross Island (Table 4.4.3-1). A large spill of crude or refined oil associated with the Proposed Action could have major adverse impacts to subsistence whaling, sealing, and waterfowl hunting for Nuiqsut (Table 4.4.3-2). If moderate to major impacts from the Proposed Action from summer construction at the Proposed LDPI site were realized as anticipated (Section 4.4.1), then effects to Nuiqsut's established system of social organization, cultural values, and formal institutions could be moderate to major. If minor to major effects from small spills to subsistence harvest patterns are realized as anticipated, then BOEM anticipates minor to major effects to occur to the sociocultural system for Nuiqsut. If major impacts from a large spill occur to Cross Island whaling as anticipated, then BOEM expects severe and thus major impacts to occur for the sociocultural system in Nuiqsut.

Impacts to subsistence harvest patterns for Kaktovik and Utqiagvik are anticipated to be less for routine activities and small spills associated with the Proposed Action than are anticipated for Nuiqsut. BOEM expects negligible impacts to the sociocultural systems for Kaktovik and Utqiagvik as a result of routine activities associated with the Proposed Action. For small spills, BOEM generally anticipates negligible impacts to sociocultural systems for Kaktovik and Utqiagvik. For Kaktovik, however, small spills of crude or refined oil could have minor to moderate effects on sealing and waterfowl hunting (Table 4.4.1-1). If these impacts were realized due to a small spill, then social organization and cultural values could be adversely affected in Kaktovik because of the importance of seals, geese, and eiders in traditional practices; impacts to the sociocultural system could be minor to moderate if hunters were present at the location of the spill when it occurred.

5.2.9.2. Discussion of Other Relevant Actions

Past, present and reasonably foreseeable infrastructure development projects across the North Slope include oil and gas development projects, marine vessel traffic, community development and capital improvement projects, and gravel mines. These various development projects are described in Section 5.1.2 and Tables 5.1.2-1 to 5.1.2-11. Other relevant actions described in Section 5.2.10.2 for

subsistence harvest patterns also apply to the discussion of cumulative effects to sociocultural systems.

Climate change would most likely be the largest contributor to cumulative effects on sociocultural systems in the NSB during the lifetime of the Proposed Action (Gamble et al., 2008).

5.2.9.3. Analysis of Cumulative Impacts to Sociocultural Systems

Past, present, and future development projects, in combination with anticipated growth in tax revenue, vessel traffic, homeland security and Coast Guard activities, and regional recreation and tourism, would most likely have additional impacts to sociocultural systems in the NSB. These actions could generate new economic activity in the form of employment, labor income, commodity prices, and property tax revenues. Cumulative impacts are expected to be long lasting and widespread, and both adverse and beneficial. For example, increased income could be used to purchase hunting and fishing equipment for subsistence activities, but development of new employment opportunities could bring outside labor to the NSB, which could threaten Iñupiaq cultural values and social organization.

Regional demographic trends toward growth and increasing diversity are likely to continue as more oil and gas and community development projects occur. In-migration from transient labor pools could increase, while out-migration of Alaska Native residents could also increase. Increased local tax revenues from new infrastructure would likely be used to expand capital budget projects and expand local infrastructure and services, such as housing, water and sewage treatment, power supply, communication networks, road construction and maintenance, construction of airstrips, docks, healthcare facilities, and public safety and search and rescue operations.

Climate change in the NSB has impacted the timing of animal migrations, access to subsistence resources, failure of village infrastructure, erosion of village land bases, and loss of food storage capacity related to permafrost decrease and ice cellar failure (ANTHC, 2014). As diminished sea ice coverage accelerates over time, several additional drivers of subsistence disruption are likely to occur from altered habitat and changes in wildlife distribution. Climate change could have regional sociocultural effects through increased economic activities such as commercial fishing, recreational fishing, renewable energy development, tourism, recreation, and marine shipping. These activities could require substantial levels of skilled labor and expensive infrastructure, which could add adverse and beneficial impacts to existing sociocultural patterns in the region. Climate change could have long lasting and widespread and thus moderate impacts on social organization, cultural values, and formal institutions that could be additive, synergistic, and countervailing to those from the Proposed Action

5.2.9.4. Conclusion

The reasonably foreseeable future actions described above could generate sociocultural impacts that are additive, synergistic, and countervailing to those from the Proposed Action. The overall cumulative impact on local and regional sociocultural systems, independent of the Proposed Action, could be long lasting and widespread and thus moderate. Growth of tax revenue on the North Slope, with corresponding growth in the capital budget and provision of government services and high-paying jobs could provide substantial local benefit; however, adverse cumulative changes in sociocultural systems could also occur. The overall contribution of the Proposed Action to cumulative effects on sociocultural systems in the NSB could be moderate.

5.2.10. Economy

5.2.10.1. Summary of Effects of the Proposed Action

The Proposed Action is expected to have negligible beneficial effects on State employment, labor income, and revenues. The beneficial impacts on NSB employment and income are likely to range

from negligible to minor, while the beneficial impacts on NSB revenues are expected to translate to moderate impacts on the NSB economy. The Proposed Action is likely to have little to no impact on the population base of the State of Alaska or the NSB. Table 5.2.10-1 (identical to Table 4.4.2-4) provides a summary of the effects of the Proposed Action on these economic measures.

Table 5.2.10-1. Effects of the Proposed Action on Economic Measures.

Economic measure:	State RA	NSB RA	State Small Oil Spills	NSB Small Oil Spills	State Large Oil Spill	NSB Large Oil Spill
Employment / Wages	Negligible	Negligible to Minor	Negligible	Negligible	Negligible	Negligible to Minor
Revenue	Negligible	Moderate	Negligible	Negligible	Negligible	Negligible
Population	Negligible	Negligible	Negligible	Negligible	Negligible	Negligible

Note: RA= Routine Activities.

Overall, the Proposed Action is expected to have a negligible beneficial impact on the State economy and a negligible to moderate beneficial impact on the NSB economy.

5.2.10.2. Description of Other Relevant Actions

The Proposed Action could add incremental benefits to the economy beyond those anticipated to result from present and reasonably foreseeable oil and gas exploration, development, and production activities. The employment, labor income, and revenues from past and current projects—especially from those in northern Alaska—have been a critical part of the economy for the State of Alaska and the NSB for decades. These activities not only provide a significant portion of State employment and labor income, but also property taxes on support infrastructure provide the vast majority of revenues for the NSB government. In recent years, there has been a decline in oil and gas activities in Alaska. The Proposed Action would add production to that now flowing through TAPS, but a single project would not be sufficient to reverse the longer-term decline in oil production and related activities.

Employment and income from construction and development of infrastructure tend to be concentrated in the relatively short “development” period for oil and gas projects. Years of oil activity have resulted in a large base of existing infrastructure, some of which can be used for future projects, with or without refurbishment or upgrades. Most existing projects are in the much longer production phase, during which operations and maintenance activities require a lower level of employment over the remaining project life. However, the work required for shutdown and abandonment of existing projects would provide very short periods with increased employment and income relative to that in the production period.

There are numerous oil and gas projects in the NSB and adjacent State waters. Oil and gas activity is expected to continue on the North Slope and in nearby waters. In addition to production from existing projects, Mustang, Alpine CD-5, Greater Mooses Tooth, and numerous small fields are expected to add production in the next few years. The Point Thomson project, which began initial production in July 2016, as well as the Alpine project, could foreseeably produce oil and gas beyond the life of the Proposed Action, and the State of Alaska could foreseeably construct and operate a natural gas pipeline to bring Point Thomson gas to market in the future. Section 5.1.2.1 includes a discussion of past, present, and reasonably foreseeable future projects, as well as related infrastructure that has been, or would need to be, developed to support oil and gas development projects. For a list of past and present oil and gas facilities in production, see Table 5.1.2-3. For lists of projects in development and discoveries likely to be developed in the reasonably foreseeable future, see Table 5.1.2-4 and Table 5.1.2-5.

Infrastructure needed to support the Proposed Action and other projects described above could include offshore and onshore pipelines, gravel mines, permanent roads, temporary ice roads, facilities supporting additional vessel and air traffic, power plants, docks and hovercraft hangers, water and sewer projects, waste handling facilities, and other support facilities. Most of these already exist, but

many would have to be refurbished, upgraded, and/or expanded. Furthermore, to the extent the existing workforce and population cannot supply needed labor, additional facilities and services would be needed to accommodate new workers and their families. The work required to provide the infrastructure and services would add to State and NSB employment and income, although much of that work would be short-term and could be fulfilled by people who do not live in the communities where the work takes place. Such infrastructure increases (or helps to maintain) a longer-term property tax base for the State and for the NSB, which depends heavily on revenues from taxes on oil-related facilities. That NSB government revenue, in turn, provides employment and income to NSB residents. This is true for onshore facilities resulting from the Proposed Action and any infrastructure that remains in place to be used for future onshore or offshore oil and gas production.

In addition to activities supporting oil and gas activities, there are—and would continue to be in the future—community development projects, local and tribal association activities, recreation and tourism, and other sources of employment and income that support NSB residents and provide new or upgraded infrastructure. Many, but certainly not all, of these are directly or indirectly possible because of NSB property tax receipts related to oil and gas activities. Some of the reasonably foreseeable infrastructure enhancements that are not directly in support of oil and gas industry needs include:

- Housing
- Systems for water supplies; waste storage and disposal; electricity; and communication
- Deep water ports to accommodate increased marine vessel traffic
- Dock and port space
- Roads
- Airstrips to accommodate larger planes
- Infrastructure for logistical, search and rescue, and military support for onshore and offshore development projects

Other activities in the Arctic may increase or start up in the duration of the cumulative case. If sea ice of the polar ice cap continues to recede, marine shipping is likely to increase. Infrastructure may need to be moved, modified, or rebuilt, and employment patterns might change somewhat due to a longer drilling season for offshore projects. Tourism and recreation are small components of the current Arctic economy but could expand modestly. In addition, commercial fishing, recreational fishing, mining, and renewable energy development may start up and expand. NOAA currently has a moratorium on commercial fishing in the Arctic but this is subject to change. These activities could also have economic impacts.

5.2.10.3. Analysis of Cumulative Impacts on Economy

Current and reasonably foreseeable projects would extend existing employment and labor income opportunities well into the future, providing employment for drilling and construction activities as well as for operations and maintenance during the production phase. The incremental contribution of activities resulting from the Proposed Action to cumulative effects on employment and income is likely to be only a small portion of the overall effects, even if important to employed individuals and their families. In addition, much of the employment and income supporting the Proposed Action and other oil and gas projects and required for construction of related infrastructure likely would go to workers commuting from southeastern Alaska or out of state, where impacts would be negligible, due to the large employment base in those areas. NSB businesses and residents have provided certain types of support activities for such projects for decades, and the reasonably foreseeable new projects identified above would generally sustain, rather than drastically increase, employment opportunities for current and future NSB workers.

While the continued use of existing infrastructure for new projects such as that in the Proposed Action may not contribute significantly to employment and income, and development of new infrastructure generally provides short-term peaks in employment, the infrastructure needed for current and future projects would provide a long-term and critical source of property tax revenues for the State and the NSB. The NSB government and local communities depend very heavily on those revenues, even more so than on employment opportunities oil and gas activities provide.

Although an unlikely event, a large spill of crude or refined oil could result from the Proposed Action or another nearby project in NSB. An oil spill between 1,000 and 5,100 barrels could generate hundreds of short-term direct and indirect jobs and thousands of dollars in personal income associated with oil-spill response and cleanup but is expected to have little adverse effects on employment and wages in other sectors of the State or NSB economies. The relatively small number of jobs and associated labor income associated with the cleanup efforts would likely have little to no effect on the State economy. The effects on the NSB economy would depend on the extent to which Borough residents are employed in the cleanup efforts, but are likely to be negligible to minor due to the temporary nature of the jobs. Potential positive revenue impacts would include property tax revenues accruing to NSB, but extra ships staged offshore would likely be the primary source of additional infrastructure used to support the response and cleanup efforts. Thus, a large spill is expected to have little to no impact on NSB revenues, resulting in a negligible effect on the NSB economy.

A dramatic increase in oil prices coupled with large new discoveries could result in a period of much higher oil and gas activities, with accompanying high levels of employment, income, revenues, and infrastructure needs. While this would benefit the State and NSB economies, it could create disruptions and also increased vulnerability to large variations in those activity levels. The development of Prudhoe Bay and the TAPS caused wide fluctuations in the population of the NSB and the State of Alaska. It also caused fluctuations in wages and prices, bringing inflation followed by deflation. An important effect of these fluctuations was their role in housing markets, driving demand beyond supply during periods of high activity and too low relative to supply when prices and activity fell suddenly. The periods of high activity and increasing population also increased the demand for public infrastructure, school systems, services, and other public needs. High oil prices, oil and gas development, in-migration of workers, and increases in the births from those who settled in Alaska during the initial boom drove population growth during the 1970s and early 1980s. Increased education and economic opportunities have led to out-migration from rural communities to urban communities throughout rural Alaska in recent decades.

Cumulative oil and gas projects and other economic activity described above could cause and be affected by similar cyclical changes, depending on volatility of oil prices and viability and size of recent and future discoveries. If future activity continues to decline because of a combination of poor results from the reasonably foreseeable projects described above and a lack of future discoveries, the NSB and the State of Alaska could experience a net migration loss, leaving under-utilized or unused infrastructure behind. Sustained very high oil and gas activity levels due to development of other projects could raise costs for the Proposed Action (higher wages and higher support costs), but activity due to the Proposed Action is not of a scale sufficient to contribute appreciably to boom conditions. Should activities supporting other projects be relatively low or decline during the relevant period, the Proposed Action would provide a limited amount of needed employment for workers and revenues for local and State businesses during economic hard times.

A long-term warming trend leading to melting of sea ice and sea-level rise could affect the structure of the economy, possibly reducing opportunities for traditional subsistence harvests on which many residents depend (see Section 5.2.11) but perhaps increasing the need for labor to modify or move existing—or build new—housing and facilities. This could create employment or increase opportunities for local residents and businesses which are able to adapt. There might also be additional employment opportunities serving modest increases in tourism, as well as vessel and

vehicle travel. Given the inherent uncertainties, it is unclear what proportion of any new employment and income opportunities would benefit long-time NSB residents—as opposed to new in-migrants or people living elsewhere—and whether losses and opportunities would accrue to the same individuals or demographic groups in the NSB.

Peak employment and related income would occur over only a few years and most of the longer-term direct production jobs are likely to be filled by workers who commute from southeastern Alaska or other parts of the U.S. However, the Proposed Action, as well as current and other future projects, would maintain existing employment opportunities for NSB residents. The property tax revenues collected by NSB from the infrastructure put in place or maintained as a result of the Proposed Action and other projects could provide long-lasting and widespread additional beneficial effects for those living in the NSB. Not only would supporting facilities remain in the tax base for decades, but tax revenues could be used to build and maintain local schools, roads, and other public facilities with even longer useful lives.

5.2.10.4. Conclusion

The Reasonably Foreseeable Future Actions described above could generate impacts on the NSB economy that are additive, synergistic, and countervailing (generating impacts that offset those of the Proposed Action, such as greater incomes for residents affected by the presence of additional non-local traffic) to those from the Proposed Action. The Proposed Action itself is likely to contribute only a relatively small proportion of the total impacts, and the additive and synergistic effects are anticipated to be negligible on the State economy and negligible to moderate on the economy of the NSB.

5.2.11. Subsistence-Harvest Patterns

5.2.11.1. Summary of Impacts

Table 5.2.11.1-1 provides a summary of impacts to subsistence harvest patterns from the Proposed Action.

Table 5.2.11-1. Impacts to Subsistence Practices for Nuiqsut, Kaktovik, and Utqiagvik.

Community	Source of Impact ¹	Whaling	Sealing	Caribou Hunting	Fishing	Waterfowl Hunting
	Proposed Action	Moderate to Major	Minor	Negligible	Negligible	Minor
Nuiqsut	Small Spills	Minor to Major	Minor to Moderate	Negligible	Negligible ²	Minor to Moderate
	Large Spill	Major	Major	Moderate to Major	Moderate to Major	Major
	Proposed Action	Negligible	Minor	Negligible	Negligible	Minor
Kaktovik	Small Spills	Negligible	Minor to Moderate	Negligible	Negligible ²	Minor to Moderate
	Large Spill	Moderate to Major	Minor to Moderate	Minor to Moderate	Moderate	Minor to Moderate
	Proposed Action	Negligible	Negligible	Negligible	Negligible	Negligible
Utqiagvik	Small Spills	Negligible	Negligible	Negligible	Negligible ²	Negligible
	Large Spill	Moderate to Major	Minor to Moderate	Minor to Moderate	Negligible	Minor to Moderate

Notes: ¹ The Proposed Action includes routine construction, development, production, and decommissioning; a number of small spills (i.e., <1,000 bbl) and one large spill (i.e., ≥1,000 bbl) are assumed to occur during the 25-year life of the Proposed Action.

² BOEM anticipates negligible impacts on subsistence fishing from small spills for Nuiqsut, Kaktovik, and Utqiagvik. However, for subsistence fishers and community residents, stress and negative perceptions of contaminated Arctic cisco, Arctic char, and broad whitefish could be minor to major depending on the location of small spills.

5.2.11.2. Discussion of Other Relevant Actions

Past, present and reasonably foreseeable infrastructure development projects across the North Slope include: oil and gas development and production projects, community development and improvement projects, and gravel mining projects to support these developments and other construction projects (see Section 5.1.2, Tables 5.1.2-1 to 5.1.2-11). Such actions, in combination with anticipated growth in vessel traffic, aircraft traffic, homeland security or coast guard activities, and regional recreation and tourism (Tables 5.1.2-1 to 5.1.2-11) would likely generate additional disturbance to fish and wildlife and could adversely affect subsistence activities and harvest patterns through displacement, altered habitat, threat of contamination, or avoidance of subsistence resources near industrial developments.

Currently, there are numerous fields producing oil on the North Slope and in nearshore areas of the Beaufort Sea, and additional fields could be developed during the 25-year life of the Proposed Action. North Slope oil and gas exploration, development, and production activities include the construction and operation of onshore and offshore pipelines, gravel mines, permanent roads, winter ice roads, construction of support facilities, and transportation activities involving surface vehicles, aircraft, or marine traffic along the coast or within the barrier islands. These activities have potential to add to the effects to subsistence harvest patterns described for the Proposed Action. This is especially the case for bowhead whaling activities and coastal caribou hunting during July and August.

Oil and gas development and production are expected to continue into the future on the North Slope. In fiscal year 2014, North Slope production averaged 531,074 barrels of oil per day (RDCA, 2015). The decline rate in production for the fiscal year was 0.1%, or essentially no decline. North Slope production was forecasted to fall 4% in 2015 to 508,000 barrels per day, increase to 519,500 barrels per day in 2016, and rise an additional 3% in 2017 to 535,500 barrels per day (RDCA, 2015).

The Point Thomson project, located approximately 60 miles east of Prudhoe Bay and 60 miles west of Kaktovik, began initial production in July 2016. The Point Thomson development could foreseeably produce oil and gas beyond the life of the Proposed Action and could add impacts to subsistence activities and harvest patterns in the region, especially if a large spill of crude or refined oil occurred. The State of Alaska could foreseeably construct and operate a natural gas pipeline to bring Point Thomson gas to market in the future. This could have additional impacts on caribou herds and habitat in the region. Added impacts to subsistence practices could be widespread and long lasting and thus moderate and would occur through displacement, altered habitat, contamination and tainting of food resources, changes to how people are able to access fish and wildlife, or avoidance of subsistence resources near developed areas associated with the Point Thomson project. Revenue to the NSB from Point Thomson development and production could create additional adverse and beneficial effects for subsistence harvesters living in the NSB that could be long lasting and widespread.

Climate change is the reasonably foreseeable event that has a great potential to result in adverse effects to subsistence harvest patterns and Arctic communities (Gamble et al., 2008). Climate change in the NSB has impacted the timing of animal migrations, access to subsistence resources, failure of village infrastructure, erosion of village land bases, and loss of food storage capacity related to permafrost decrease and ice cellar failure (ANTHC, 2014). Climate change would most likely adversely affect caribou habitat and caribou herds. Nuiqsut, Kaktovik, and Utqiagvik are among a number of NSB communities that rely upon caribou as a subsistence resource. Dwindling stocks would result in reduced hunting success and could have a ripple effect throughout sociocultural systems. These effects would be experienced in addition to those associated with the Proposed Action and could be long lasting and widespread.

Climate change, with resultant loss of summer sea ice and an open Northwest Passage, is already drawing visitors associated with recreation and tourism industries. Additional vessel traffic, especially cruise ship traffic, air traffic, and local barge and aircraft traffic, could impede subsistence harvests,

as much of the visitation would occur during the prime season for subsistence harvests of whales, seals, caribou, and fish. Pressure from increased recreational hunting and fishing could further exacerbate adverse impacts on subsistence hunting and fishing for Nuiqsut, Kaktovik, and Utqiagvik.

Community and regional development is ongoing and could accelerate in the future. Infrastructure necessary to support demand for efficient energy and modernization of existing communities would most likely be constructed. Reasonably foreseeable construction and development activities on the North Slope could include:

- Gravel mines
- Power plants
- Modern housing
- Airports, helipads, and hangers
- Marine transportation improvements
- Docks and hovercraft hangers
- Search and rescue facilities
- Water and sewer projects
- Solid waste handling facilities
- Roads
- Schools
- Other infrastructure and capital improvements

Subsistence harvesters across the North Slope could benefit in many ways from construction of these facilities, but might also experience long lasting and widespread adverse impacts to subsistence harvest patterns unless government agencies actively solicit local perspectives and traditional knowledge to guide development, and use the information in siting of infrastructure, work timing, and implement other means to avoid or reduce effects on subsistence activities and harvest patterns.

5.2.11.3. Analysis of Cumulative Impacts to Subsistence Harvest

The incremental contribution of activities associated with the Proposed Action to cumulative effects on subsistence harvest practices would most likely vary in accordance with the type of activity, seasonal timing, fish and wildlife migration patterns, amount of tax revenue, and numbers of people drawn to the area for employment or recreation and tourism.

The Point Thomson and Alpine developments nearby could foreseeably produce oil and gas beyond the life of the Proposed Action and could add impacts to subsistence activities such as caribou hunting in the region, especially if a large spill of crude or refined oil occurred. Revenue to the NSB from Point Thomson and Alpine development and production could create additional adverse and beneficial effects for subsistence harvesters living in the NSB that could be long lasting and widespread. A large oil spill associated with the Proposed Action could have additional adverse impacts on subsistence caribou hunters from Nuiqsut and Kaktovik. Whalers from Nuiqsut currently avoid scouting for whales near the Northstar offshore development. If they avoid whaling activities near the proposed LDPI, loss of additional opportunities for hunting bowhead whales would occur.

Future onshore and offshore oil and gas development and production projects on the North Slope could lead to construction of additional industrial infrastructure. The additional effects of past, present, and future oil and gas development to subsistence harvest patterns could be long lasting and widespread and thus moderate. If construction and associated vessel and air traffic occur during the winter months and cease before the Nuiqsut bowhead whale hunt, impacts to subsistence whaling and other marine subsistence uses would most likely be minor. Given reasonably foreseeable development

of oil and gas in the region, the incremental, additive and synergistic effects of the Proposed Action to subsistence harvest patterns could be minor to moderate.

If efforts are made to avoid the primary marine subsistence areas of Nuiqsut and Kaktovik, minor to moderate impacts could be reduced to minor.

Impacts of past, present, and reasonably foreseeable future activities related to economic development and increased revenue could be long lasting and widespread and both adverse and beneficial. Many of the current and foreseeable capital improvements would be specific to certain villages and would most likely have short-term and localized effects in addition to the effects of the Proposed Action. However, some community development projects such as new or expanded airports and marine transport infrastructure could have regional level effects, both adverse and beneficial, that could be long lasting and widespread and thus moderate. This is especially the case for developments that allowed more people to settle in the communities of the NSB. There could be added competition for hunting and fishing opportunities.

The cumulative impacts of all existing and future activities in the NSB, including the Proposed Action, could be additive and synergistic to those from local and global anthropogenic activities that contribute to global climate change. Climate change is likely to affect the habitat, behavior, abundance, diversity, and distribution of populations of subsistence species, thereby indirectly affecting subsistence harvest patterns. Additive and synergistic impacts could be short term and localized or long lasting and widespread depending on the extent to which availability of and access to subsistence resources are adversely affected by climate change.

Communities reliant on marine-based hunting and fishing would most likely be affected to the greatest extent, as would individuals and communities dependent on subsistence harvest of marine mammals as essential elements of their food security and cultural well-being. The small number of jobs, high cost of living, and rapid social change make rural communities highly vulnerable to climate change through impacts on traditional hunting and fishing and cultural connection to the land and waters. Subsistence harvest opportunities may be affected by potential shifts in hunting seasons and harvest opportunities due to shifts in distribution or abundance of favored species. Economic losses to coastal and riverine communities due to increased travel times and fuel expenditures may occur as traditional harvest species change their relative location and abundance. Temperature, precipitation, and landscape and ice changes may alter access to subsistence resources, including changes to wetlands or access to winter sea ice and frozen rivers used for travel by subsistence harvesters. Cumulative impacts to subsistence harvest patterns from climate change are anticipated to be long lasting and widespread and thus moderate and additive to those anticipated from the Proposed Action.

Subsistence harvest practices, which are integral to maintaining Iñupiaq cultural practices and foundational to the entire sociocultural system, would most likely continue throughout the life of the Proposed Action. The past century has seen adherence to the subsistence way of life and a mixed subsistence-cash economy despite rather large social and cultural changes due to Westernization and globalization in the NSB. As in the past, it seems likely that subsistence practices would adapt to present and reasonably foreseeable future activities, and would continue throughout this century and well into the next. This assumes that efforts by regulators and industry to avoid and mitigate impacts from current and future development activities and monitor subsistence harvest patterns by working with residents of the North Slope and their formal institutions such as the NSB and the Alaska Eskimo Whaling Commission.

5.2.11.4. Conclusion

The reasonably foreseeable future actions described above could cause effects to subsistence activities and harvest patterns that are additive, synergistic, and countervailing to those from the Proposed Action. The cumulative effects of oil and gas development, community development, and

climate change on subsistence harvest patterns could be long lasting and widespread. The overall contribution of the Proposed Action to cumulative impacts on subsistence activities and harvest patterns could be moderate.

5.2.12. Community Health

5.2.12.1. Summary of Impacts

Availability of, and access to, subsistence foods and other local subsistence resources are critical determinants of community health and cultural well-being in the NSB. Potential impacts to community health from the Proposed Action due to loss of subsistence bowhead harvests and other harvest opportunities could be moderate. Impacts of air pollution and emissions from routine construction, development, and production on community health are expected to be minor. BOEM anticipates negligible impacts on community health related to water quality. Beneficial impacts to community health from revenue and economic growth are expected to range from negligible to moderate. Adverse impacts to community health related to economic growth would most likely be minor. Overall, impacts on community health as a result of the Proposed Action are anticipated to be negligible to moderate.

Effects to community health from small accidental spills occurring during the life of the Proposed Action are expected to be minor. For a large oil spill, impacts to community health for Nuiqsut could be major. Impacts to community health for Kaktovik and Utqiagvik from a large oil spill are expected to be moderate to major, depending on the size and location of a spill and whether or not impacts disrupt subsistence harvest activities for one or more seasons, alter local healthcare services, disrupt traditional sharing networks, and/or threaten cultural values and identities.

5.2.12.2. Discussion of Other Relevant Actions

Past, present and reasonably foreseeable infrastructure development projects across the North Slope include oil and gas development projects, marine vessel traffic, community development and capital improvement projects, and gravel mines. These various development projects are described in Section 5.1.2 and Tables 5.1.2-1 to 5.1.2-11. Other relevant actions described in Section 5.2.11 for subsistence harvest patterns also apply to the discussion of cumulative effects to community health.

Climate change would most likely contribute to cumulative effects to community health in the NSB during the lifetime of the Proposed Action (Gamble et al., 2008).

5.2.12.3. Analysis of Cumulative Impacts to Community Health

Past, present, and future actions, in combination with anticipated growth in vessel and aircraft traffic, homeland security and coast guard activities, commercial shipping, and regional recreation and tourism, would most likely generate additional disturbance to subsistence harvest patterns, sociocultural systems, and community health through displacement, altered habitats, contamination and perceived tainting of food resources, and possible avoidance of some resources by harvesters.

These actions could generate new economic activity in the form of employment, labor income, commodity prices, and property tax revenues, which could further impact sociocultural systems and, by extension, community health in both adverse and beneficial ways. Increased local tax revenues from new infrastructure would likely be used to expand capital budget projects and local infrastructure and services such as housing, water and sewage treatment, power supply, communication networks, road construction, and improved healthcare facilities.

The incremental contribution of activities associated with the Proposed Action to cumulative effects on community health would vary in accordance with the type and level of impacts to subsistence harvest practices and sociocultural systems. It is assumed that future oil and gas development and production in the Beaufort Sea would result in the construction of additional gravel islands or drilling

platforms and miles of connecting pipelines to extract oil and gas and bring it to market. The effects of future oil and gas development and production could range from minor to major, depending upon the time of the year of each activity and whether a large spill were to happen. If construction occurs during the winter months and ceases sufficiently in advance of the Nuiqsut bowhead whale hunt, it would likely have minor effects on subsistence whaling and sociocultural systems, and therefore, impacts to community health from future oil and gas production would most likely be negligible to minor. If a large oil spill happened, community health could be moderately to majorly impacted, depending on the extent of damage to subsistence resources, diets, and nutritional status and community well-being. A large oil spill could adversely impact social relationships and sharing networks, especially if subsistence harvests decreased due to oil spills caused by future oils and gas production.

Climate change would most likely have moderate to major adverse effects on residents of the NSB during the 25-year lifetime of the Proposed Action. As diminished sea ice coverage accelerates and temperatures warm overtime, several additional drivers of impacts to subsistence harvest patterns, social organization, and cultural values could manifest as adverse impacts to community health such as food insecurity, decreased nutritional status, loss of traditional practices and sharing networks, or social and psychological stresses. The Proposed Action could have additive and synergistic adverse effects to public and community health. These impacts could be short term and localized or long lasting and widespread depending on the extent of changes to subsistence harvest patterns and social organization.

5.2.12.4. Conclusion

The reasonably foreseeable future actions described above would most likely generate impacts to community health by impacting subsistence harvest patterns and sociocultural systems. These impacts would be additive, synergistic, and countervailing (generating adverse impacts that are offset by beneficial impacts) to those from the Proposed Action. The contribution of the Proposed Action to cumulative impacts on local and regional subsistence harvest and sociocultural patterns could be long lasting and widespread and thus moderate. Growth of tax revenue on the North Slope, with corresponding growth in the capital budget and provision of government services and high-paying jobs could provide moderate levels of benefit to local community health due to infrastructure construction such as medical facilities, healthcare facilities, schools, and modern energy efficient homes. Overall, the incremental contribution of the Proposed Action to cumulative effects on community health would be moderate.

5.2.13. Environmental Justice

Iñupiat peoples are a recognized minority and the predominant residents of Beaufort Sea coastal communities in the NSB. Disproportionate high and adverse effects on the Iñupiat would most likely occur due to their cultural reliance on subsistence foods and through the additive and synergistic effects of climate change. Cumulative effects could affect subsistence harvest patterns, sociocultural systems, and community health. Cumulative impacts from past, present, and future actions are most relevant for the Iñupiat communities of Nuiqsut and Kaktovik because these are located nearest the Proposed Action Area.

Other relevant actions that could affect subsistence harvest patterns, sociocultural systems, and community health in these communities include potential increased seismic-survey activity; oil spills; noise and traffic disturbance from construction, marine vessels, and helicopters; and disturbances and interferences from building ice roads, production facilities, pipelines, and gravel mines. Nuiqsut is located in an expanding area of oil and gas exploration and development onshore (e.g., Alpine and Northwest NPR-A). The Point Thomson Project is located in the traditional hunting and fishing grounds of both Nuiqsut and Kaktovik. Nearshore and onshore oil and gas development along with

seismic-exploration activity and potential drilling operations offshore Kaktovik could disproportionately impact these minority communities and create environmental justice issues.

In the event of a large spill, many harvest areas and some subsistence resources could be unavailable for use. Some resource populations could suffer losses and, as a result of tainting or perceived tainting, bowhead whales could be rendered unavailable for use for one or more seasons. Major additive effects could occur when impacts from contamination of the shoreline, tainting concerns, spill response and cleanup disturbances, and disruption of subsistence practices are factored together.

Cumulative effects to social organization and cultural values could include decreased importance of the family, cooperation, sharing and subsistence as a livelihood, and increased individualism, wage labor, and entrepreneurship. Long-term effects on subsistence harvest patterns could occur. North Slope subsistence harvesters have stated that there is a decline of fish populations due to onshore seismic surveys, caribou have been diverted from traditional migration routes and calving areas due to increased low-flying aircraft, caribou movements are disrupted due to the presence of low pipelines, and hunters have been displaced from some traditional harvest areas due to avoidance of industrial developments.

Although Nuiqsut and Kaktovik still have large areas that are relatively undisturbed, the general subsistence hunting environment continues to change in response to increased development and climate change. The continued expansion of oil and gas development between the Colville and Canning Rivers would increase the area considered off-limits by subsistence harvesters, could deflect or divert important subsistence resources from current routes of travel, and requires hunters to travel farther to harvest subsistence foods at a greater cost in time, fuel, equipment, and lost wages. Climate change would most likely cause disproportionate high and adverse environmental and health effects to subsistence harvester in Nuiqsut, Kaktovik, and across the North Slope (ANTHC, 2014; Gamble et al., 2008; Trainor et al., 2007). The effects of climate change in the NSB would most likely be long-term and widespread. The Proposed Action and other reasonably foreseeable future actions in the NSB would most likely have an adverse but varied impact on environmental justice communities, depending on each community's ability to adapt to changing conditions.

Tax revenue paid to the NSB from the oil and gas industry would most likely continue to provide cumulative benefits, including increased funding for infrastructure, higher incomes, better healthcare, and improved educational facilities. For communities like Nuiqsut that are relatively close to industrial developments, these economic benefits could also have adverse effects on the sociocultural system.

The additive cumulative effects of past, present, and future projects to the subsistence way of life in the NSB over the 25-year life of the Proposed Action could become more severe. Potential impacts on human health and social organization could be major. Impacts to culture and infrastructure of subsistence-based communities in the NSB could be disproportionately high and adverse.

5.2.13.1. Conclusion

The Proposed Action could contribute additive and synergistic impacts, as well as countervailing impacts (generating adverse impacts that are offset by beneficial impacts) to Iñupiat culture and social structure, especially if a large spill of crude or refined oil happened. Minority residents of Nuiqsut and Kaktovik could experience disproportionate high and adverse effects due to the incremental contribution of the Proposed Action to cumulative impacts on subsistence harvest patterns, sociocultural systems, and community health.

5.2.14. Archaeological Resources

5.2.14.1. Summary of Impacts

Direct effects to historical and archaeological resources include activities that physically impact the conditions or the integrity of the resource. These include but are not limited to the following:

- Drilling
- Excavation for pipeline on- and offshore
- LDPI placement
- All infrastructure associated with the Proposed Action involving ground disturbance

Anything that involves ground disturbance in a previously undisturbed area could be subject to archaeological surveys, analysis, reports, and consultation for compliance with Sec. 106 of the NHPA of 1966 as amended, as any of these activities could result in direct effects to surface or subsurface historic or archaeological resources, either on- or offshore.

Onshore historic and archaeological resources are susceptible to impacts from: (1) inadvertent damage, (2) looting as a result of increased access or local activity, and (3) visual effects to historic or archaeological traditional cultural properties.

Impacts to historic and archaeological resources resulting from implementation of the Proposed Action could result in adverse effects if an archaeological site is impacted.

5.2.14.2. Discussion of Other Relevant Actions

Additional oil and gas development in the OCS could create synergistic and additive effects through construction, pipeline routes and onshore roads, borrow pits, and other expansion involving ground disturbance would proceed subject to Section 106 consultation.

Climate Change is the reasonably foreseeable event with the greatest potential to both change the baseline and result in adverse effects to both on and offshore historic and archaeological resources. Melting permafrost, rising sea levels, shoreline erosion, storm surges, drying of lakes and ponds, and changing of river courses all have the present and reasonably foreseeable future effect of destroying, flooding, or altering the context and integrity of historic and archaeological resources. These adverse impacts would occur regardless of Federal oversight, and a great many historic and archaeological resources, previously unidentified and undocumented, could be lost.

Infrastructure necessary to support Arctic expansion and modernization of existing communities would continue to be constructed. Most, if not all, of these projects would require a Federal license, permit, funds or otherwise be linked to Federal involvement, and thus would be under the auspice of the NHPA and attendant codes of Federal regulation. Climate change, with resultant loss of summer sea ice and an open Northwest Passage, would likely draw visitors associated with recreation and tourism industries. Many of these may well be outside of the purview of the NHPA, yet would have the potential to cause adverse impacts to historic and archaeological resources.

5.2.14.3. Analysis of Cumulative Impacts

In general, impacts to archaeological resources would be managed under NHPA with associated inventory, assessment, evaluation of effects, and mitigation plans. With regard to climate change, adverse effects on historic and archaeological sites have been and will continue to be uncontrolled and undocumented. There are no comprehensive plans underway to organize broad scale efforts to identify, document, and assess vulnerable and threatened sites. Despite this drawback, it can be assumed that the number of historic and archaeological resources would increase through identification efforts resulting from federally-licensed, leased, permitted, and funded activities. The

historic preservation process is fundamental to providing greater insight and understanding of the past. The discovery of any archaeological site in the Chukchi Sea, for example, would have profound significance in providing insight into the earliest human expansion to what is now North America. Thus, while effects on historical and archaeological sites would be major if they were to receive direct adverse impacts, the overall effect of knowledge gained from site identification during planning stages would represent a countervailing effect by contributing in a major way toward unlocking the secrets of the past.

5.2.14.4. Conclusion

The contribution of activities associated with the Proposed Action to cumulative effects on historic and archaeological resources would range from negligible to major, depending upon the ability to identify, avoid, or mitigate historic and archaeological resources during the early planning stages. With the safeguards already in place through NHPA and the Federal permitting process, the activities associated with the Proposed Action are unlikely to produce harmful effects. However, if an unknown site is impacted by the Proposed Action and the information that site could have provided is lost, then the overall contribution to cumulative impacts to archaeological resources would be major.

Consultation and Coordination

List of Preparers

Page Intentionally Left Blank

Table of Contents

Chapter 6. Consultation, Coordination, Preparer List 6-1

 6.1. Development of this DEIS 6-1

 6.2. Consultation 6-1

 6.2.1. Tribal Consultation 6-1

 6.2.2. ESA Section 7 6-1

 6.2.3. Essential Fish Habitat Consultation 6-2

 6.2.4. Section 106, National Historic Preservation Act Consultation..... 6-2

 6.3. Document Preparers 6-2

List of Tables

Table 6-1. Primary Contributors to this EIS. 6-2

This page intentionally left blank

CHAPTER 6. CONSULTATION, COORDINATION, PREPARER LIST

6.1. Development of this DEIS

The Liberty DPP DEIS was developed by BOEM, the lead agency, with five cooperating agencies, and released to the public on July 28, 2017 through a press release and posting on the bureau's website at <https://www.boem.gov/liberty/>.

6.2. Consultation

BOEM has engaged in several consultation and coordination processes in regards to proposed activities in the Liberty Development and Production Plan. Below is a brief summary of how BOEM has satisfied, or will satisfy, its various consultation requirements.

6.2.1. Tribal Consultation

Executive Order 13175 requires Federal agencies to consult, on a government-to-government basis, with Federally-recognized Indian tribes (to include Alaska Native tribes) when developing Federal policies with tribal implications. The purpose is to "have an accountable process to ensure meaningful and timely input by tribal officials in the development of regulatory policies that have tribal implications."

BOEM has determined that Development and Production activities in the Beaufort Sea could have tribal implications for the villages of Nuiqsut, Kaktovik, and Utqiagvik. BOEM has offered to consult with each of these tribal governments at venues within various North Slope villages, or in the alternative, via telephone (an accepted communications practice among tribal members and within the villages of the North Slope Borough).

For this DEIS, BOEM has conducted, thus far, government-to-government tribal consultations by delivering letters to and holding meetings with tribes whose members could be affected by the Liberty DPP activities, including:

- Native Village of Kaktovik
- Native Village of Nuiqsut
- Native Village of Utqiagvik
- Inupiat Community of the Arctic Slope (note: also a Participating Agency)

BOEM has conducted, thus far, government-to-ANCSA Corporation consultations and/or meetings with ANCSA corporations whose members could be affected by the Liberty DPP activities, including:

- Arctic Slope Regional Corporation
- Nuiqsut - Kuupik Corporation
- Kaktovik – Kaktovik Inupiat Corporation
- Utqiagvik – Ukpeagvik Inupiat Corporation (UIC)

BOEM anticipates additional consultations and meetings in Fall 2017 with the entities listed above. BOEM is grateful for the continued participation and support from the Inupiat Community of the Arctic Slope, a Participating Agency on the EIS, and Arctic Slope Regional Corporation, which volunteered to translate a of summary project documents into Inupiaq.

6.2.2. ESA Section 7

Section 7(a)(2) of the ESA requires each federal agency to ensure that any action that it authorizes, funds, or carries out is not likely to jeopardize the continued existence of a listed species or result in

the adverse modification of designated critical habitat. To satisfy its ESA obligations, BOEM and its cooperating agencies have initiated formal consultation processes with NMFS and USFWS concerning activities described in the proposed DPP.

6.2.3. Essential Fish Habitat Consultation

The Magnuson-Stevens Fishery Conservation and Management Act (as amended) requires Federal agencies to consult with NMFS regarding actions that may adversely affect designated Essential Fish Habitat (EFH). BOEM is currently preparing an EFH assessment that will identify any adverse effects to designated EFH from potential oil and gas exploration activities in the proposed Lease Sale Area.

6.2.4. Section 106, National Historic Preservation Act Consultation

The National Historic Preservation Act requires Federal agencies to consult with the appropriate State Historic Preservation Officer (SHPO) regarding any agency undertaking with the potential to affect historic properties. BOEM will initiate Section 106 consultation with the Alaska SHPO for the Liberty DPP upon release of the DEIS.

6.3. Document Preparers

BOEM staff with expertise in the appropriate scientific, economic, and sociocultural disciplines contributed to the development of this DEIS and the analysis herein. Table 6-1 lists the primary individuals involved in preparing and reviewing the Liberty DEIS.

Table 6-1. Primary Contributors to this EIS.

Name	Title
Lauren Boldrick	Project Manager
Jeff Brooks	Sociocultural Specialist
Chris Campbell	Sociocultural Specialist
Chris Crews	Biologist
Albert Csaszar	Petroleum Engineer
Maureen DeZeeuw	Biologist
Lorena Edenfield	Biologist
Pamela Grefsrud	Biologist
Tim Holder	Arctic Liaison
Melanie Hunter	NEPA Coordinator
Joel Immaraj	Petroleum Engineer
Virgilio Maisonet-Montanez	Meteorologist
Frances Mann	Project Coordinator
Craig Perham	Biologist
Kristen Strellec	Economist
William Swears	Writer/Editor

This page intentionally left blank



The Department of the Interior Mission

As the Nation's principal conservation agency, the Department of the Interior has responsibility for most of our nationally owned public lands and natural resources. This includes fostering the sound use of our land and water resources; protecting our fish, wildlife, and biological diversity; preserving the environmental and cultural values of our national parks and historical places; and providing for the enjoyment of life through outdoor recreation. The Department assesses our energy and mineral resources and works to ensure that their development is in the best interests of all our people by encouraging stewardship and citizen participation in their care. The Department also has a major responsibility for American Indian reservation communities and for people who live in island communities.



The Bureau of Ocean Energy Management Mission

The Bureau of Ocean Energy Management (BOEM) manages development of U.S. Outer Continental Shelf energy and mineral resources in an environmentally and economically responsible way.