

OPEN FILE REPORT
83-124
AUGUST 1983

**GEOLOGIC AND OPERATIONAL
SUMMARY, NORTON SOUND
COST NO. 1 WELL
NORTON SOUND
ALASKA**

DEPARTMENT OF THE INTERIOR
UNITED STATES GEOLOGICAL SURVEY
MINERALS MANAGEMENT SERVICE

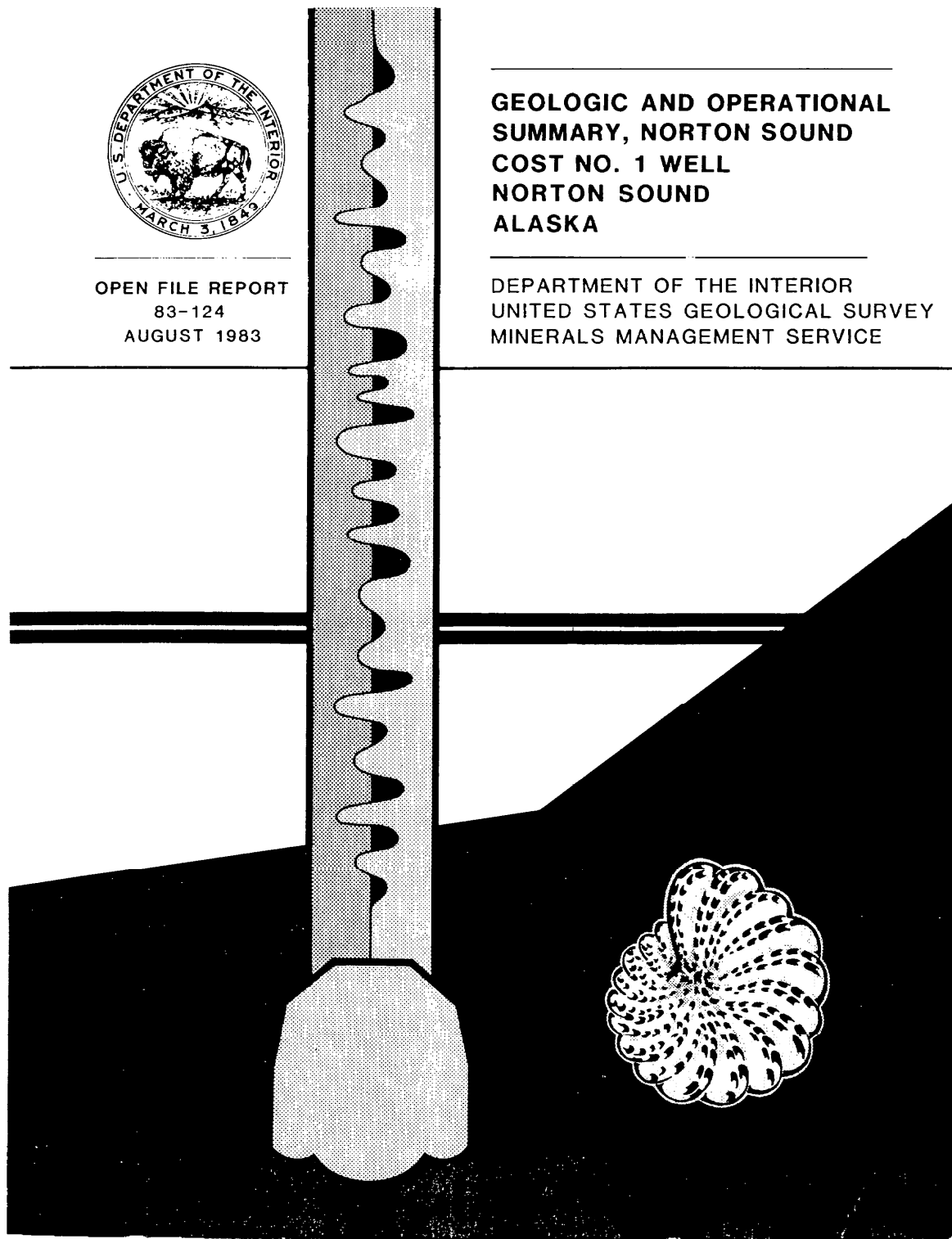

UNITED STATES DEPARTMENT OF THE INTERIOR
MINERALS MANAGEMENT SERVICE

Geological and Operational Summary
Norton Sound COST No. 1 Well
Norton Sound, Alaska

R. F. Turner (ed), J. G. Bolm, C. M. McCarthy,
D. A. Steffy, Paul Lowry, and T. O. Flett

U.S. GEOLOGICAL SURVEY
OPEN-FILE REPORT 83-124

This report has not been edited for conformity with Minerals Management Service and U.S. Geological Survey editorial standards or stratigraphic nomenclature.

Any use of trade names is for descriptive purposes only and does not constitute endorsement of these products by the Minerals Management Service and Geological Survey.

CONTENTS

	<u>Page</u>
Introduction	1
Operational Summary	5
Shallow Geologic Setting	17
Seismic Reflection Correlation and Velocity Analysis	21
Paleontology and Biostratigraphy	39
Geophysical Log Interpretation	58
Geochemistry	98
Environmental Considerations	129
Summary and Conclusions	141
References	153
Appendix	A1-A6

ILLUSTRATIONS

Figure 1. Location map	3
2. Final location plat	8
3. Graph showing daily drilling progress	10
4. Schematic diagram showing casing, strings, plugging, and abandonment program	11
5. Changes with depth of drilling properties.	14
6. Location diagram showing Norton Basin, COST wells 1 and 2, and USGS seismic lines	22
7. Synthetic Seismogram	23
8. USGS seismic line 807	25
9. USGS seismic line 813	26
10. USGS seismic line 802	27
11. Time-stratigraphic column and seismic profile	28

ILLUSTRATIONS (cont.)

	<u>Page</u>
12. Comparison between stacking velocities and RMS velocities	32
13. Interval velocities and time-depth curve from sonic log of COST No. 1 well	33
14. Interval velocities and time-depth curves from seismic data near COST No. 1 well	35
15. Comparison between time-depth curves derived from seismic and sonic data for COST No. 1 well	36
16. Comparison between time-depth curves for COST wells 1 and 2	38
17. Biostratigraphic correlation of Norton Sound COST wells	51
18. Stratigraphic summary of Norton Sound COST No. 1 well	52
19. Stratigraphic summary of Norton Sound COST No. 2 well	53
20. Description of conventional core 2, Norton Sound COST No. 1 well	64
21. Description of conventional core 3	65
22. Description of conventional core 4	66
23. Description of conventional core 5	69
24. Description of conventional core 6	72
25. Description of conventional core 7	77
26. Description of conventional core 8	78
27. Description of conventional core 9	79
28. Description of conventional core 10	82
29. Description of conventional core 11	85
30. Description of conventional core 12	86
31. Plot of average porosity against depth for conventional core sandstone samples	92

ILLUSTRATIONS (cont.)

	<u>Page</u>
32. Plot of average permeability against average porosity for conventional sandstone samples	93
33. High-resolution thermometer data	100
34. Classification of organic matter	102
35. Van Krevelen diagram. Elemental analyses	104
36. Van Krevelen diagram. (Selected pyrolysis analyses by Geochem Laboratories, Inc.)	105
37. Selected indicators of thermal maturation	107
38. Organic richness and hydrocarbon potential	112
39. Representative C ₁₅ + gas chromatograms	118
40. Representative C ₁₀ + gas chromatograms	119

Plate 1. Stratigraphic column and summary chart of Geologic Data, COST No. 1 well, Norton Sound, Alaska

TABLES

Table 1. Basalt chemistry data	74
2. Porosity and permeability, Norton 1	88
3. Potassium-argon age determinations	96
4. Selected geochemical data from samples	116
5. Carbon isotope ratios ($\delta^{13}C$) in parts per thousand from heavy hydrocarbon extracts	121
6. Summary of hydrocarbon potential indicators in organically rich horizons	127

Geologic and Operational Summary

Norton Sound COST No. 1 Well

Norton Sound, Alaska

Ronald F. Turner, Editor

INTRODUCTION

Title 30, Code of Federal Regulations (CFR), paragraph 251.14 stipulates that geological data and processed geological information obtained from Deep Stratigraphic Test wells drilled on the Outer Continental Shelf (OCS) be made available for public inspection 60 calendar days after the issuance of the first Federal lease within 50 nautical miles of the wellsite or 10 years after completion of the well if no leases are issued. Tracts within this distance of the first Norton Sound Deep Stratigraphic Test well (designated the ARCO Norton Sound COST No. 1 Well by the operator and hereafter referred to as the well or the No. 1 well) were offered for lease in Sale 57 on March 15, 1983. Ninety-eight bids on 64 tracts were received with the total high bids amounting to \$325 million. Fifty-nine bids were accepted and five rejected. The effective issuance date of the leases is June 1, 1983.

This open-file report is presented in accordance with the requirements of 30 CFR 251.14. The interpretations contained herein are chiefly the work of Minerals Management Service personnel, although substantial contributions were made by geoscience consulting companies.

The ARCO Norton Sound COST No. 1 well was completed on September 16, 1980, on OCS Lease Block 197, located approximately 54 miles south of Nome, Alaska (fig. 1). The well data is available for public inspection at the Minerals Management Service, Offshore Field Operations office, located at 800 "A" Street, Anchorage, Alaska, 99501.

All measurements are given as measured depths in feet from the Kelly Bushing (KB) which was 98 feet above sea level. For the most part, measurements are given in U.S. Customary Units except where scientific convention dictates metric usage. A conversion chart is provided.

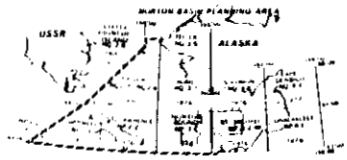

SALE 57 HISTORY



NORTON BASIN SALE 57 AREA

COST WELL

TRACTS DELETED FROM SALE 57

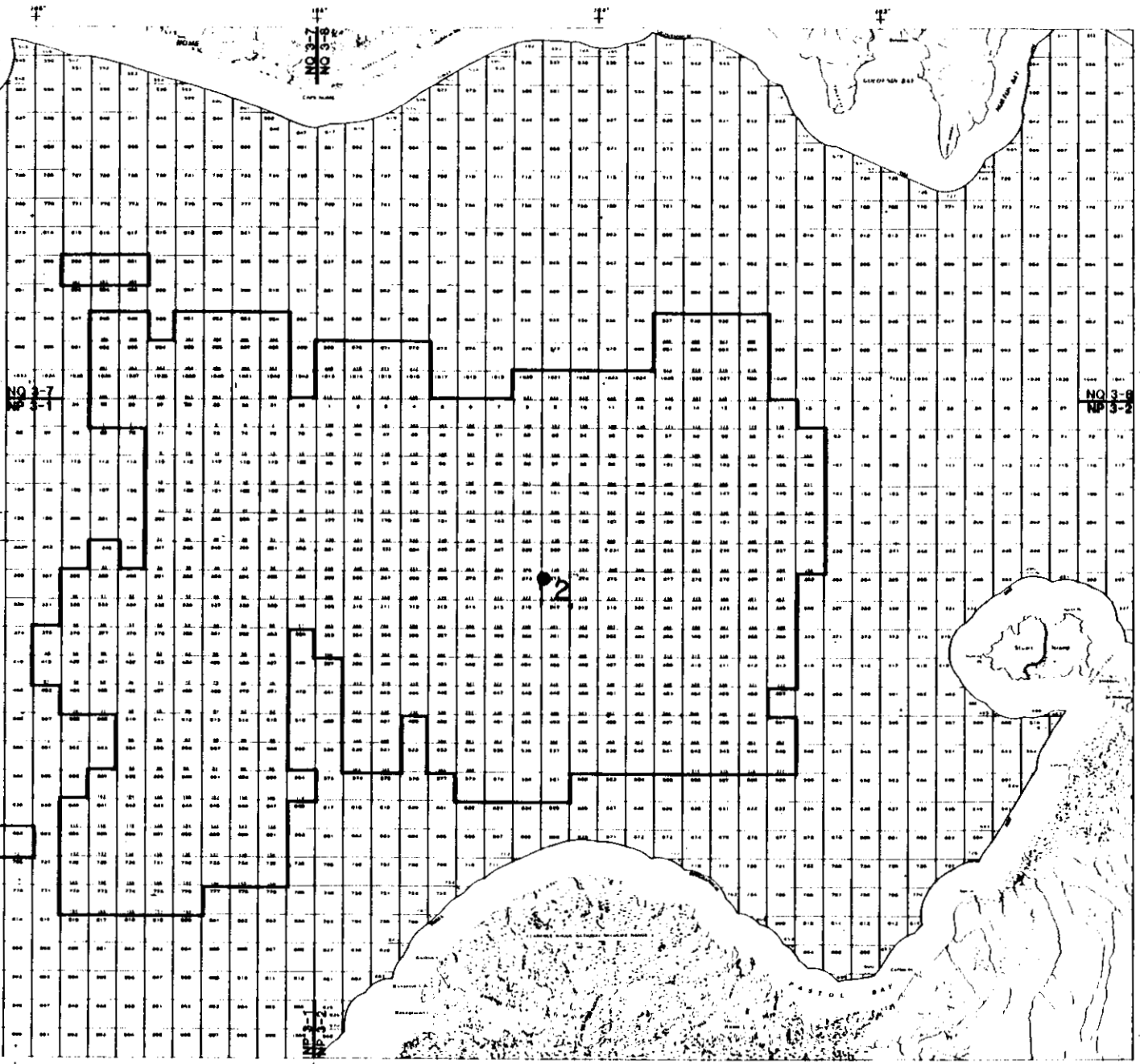
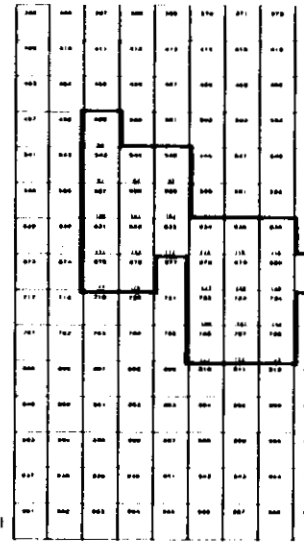

Figure 1. Location Map showing Norton Basin Sale 57 Area and COST Wells 1 and 2.

3

EQUIVALENT MEASUREMENT UNITS

U.S. Customary to SI Metric Units:

1 inch = 2.54 centimeters

1 foot = 0.3048 meter

1 statute mile = 1.61 kilometers

1 nautical mile = 1.85 kilometers

1 pound = 0.45 kilogram

1 pound/gallon = 119.83 kilograms/cubic meter

1 pound/square inch = 0.07 kilograms/square centimeters

1 gallon = 3.78 liters (cubic decimeters)

1 barrel = (42 U.S. gals.) = 0.16 cubic meters

Temperature in degrees Fahrenheit = °F less 32, divided by 1.8 for degrees Celsius.

Other Conversions: 1 knot = 1 nautical mile/hour

1 nautical mile = 1.15 statute miles or 6,080 feet

OPERATIONAL SUMMARY

by

Colleen McCarthy

The jackup rig Dan Prince arrived on location in Norton Sound on June 12, 1980, 1800 hours A.S.T. and the Norton Sound Continental Offshore Stratigraphic Test (COST) No. 1 well was spudded June 14, 1980. Drilling was completed 94 days later on September 16, 1983, at a measured depth of 14,683 feet. After wireline logging, sidewall coring, and drill-stem testing, the well was plugged and abandoned and the rig under tow by September 30, 1980.

The drilling rig Dan Prince is a self-elevating drilling unit owned by DAN-TEX, Inc. The rig is rated for drilling up to 25,000 feet deep in water up to 300 feet deep, 109-knot winds, and 50-foot waves. The rig has a storage capacity of 1500 tons. The predrill inspection and mobilization took place at Homer, Alaska, before the rig was towed to the drilling location in the Norton Sound. There were no major accidents or incidents on the Dan Prince during the drilling of the well.

Nome, which is approximately 54 miles NNE from the well location, served as the shore base for sea- and air-support operations, and Kenai was an occasional source of nonroutine equipment and materials supply. Two sea-going supply vessels transported drilling materials and supplies, including fuel, to the rig. They operated out of existing dock facilities at Nome and Kenai, or,

depending upon weather and availability of supplies and support facilities, intermittently from each of these points. A large sea-going storage barge was also used to transport some materials from Kenai and was anchored near the location. Helicopters certified for instrument flight were used to transport personnel, groceries, and light weight equipment between the rig and the primary shore base at Nome. At times personnel, equipment, and supplies were also transported to and from the shore base by both chartered and commercial air carriers.

ARCO Oil and Gas Company acted as the operator for itself and the sixteen participating petroleum companies listed below that shared expenses for the well:

American Petroleum Company of Texas
AMOCO Production Co.
Chevron, U.S.A., Inc.
Cities Service Co.
Continental Oil Co.
Elf-Aquitane Exploration Ltd.
Getty Oil Co.
Gulf Oil Exploration and Production Co.
Marathon Oil Co.
Mobil Exploration and Producing Services, Inc.
Pennzoil Co.
Phillips Petroleum Co.
Shell Oil Co.
Sohio Petroleum Co.
Sunmark Exploration Co.
Union Oil Company of California

Norton Sound COST No. 1 well was located at lat 63° 46 ft 48.97" N.; long 166° 05 ft 10.40" W., or UTM coordinates (zone 3) X = 446,453.5 m and Y = 7,072,787.9 m. The survey plat for the final well site location is shown in Figure 2. Water depth at location is 90 feet. All measurements were made from the Kelly Bushing which was 98 feet above sea level and 188 feet above mudline. The well was drilled to total depth with no more than 1° deviation from vertical.

Drilling stipulations required the operator to provide the Minerals Management Service (formerly USGS, Conservation Division) with all well logs, samples, core slabs, geologic information, and operational reports.

Pack ice, sea-ice coverage, and ice breakup data showed that the earliest that operations could be initiated in Norton Sound was mid-June, and the latest that operations could continue was mid-October.

An additional consideration for initiating and terminating operations with a jackup rig was storm occurrence. In Norton Sound storms occur less frequently in June, July, and August than in other months. A good wind and wave forecast program was essential to set up a jackup rig. More frequent storm occurrence and rougher sea conditions in the latter part of the operating season made reliable wind and wave forecasts vital to demobilization; lowering the hull and floating the jackup rig away from location. The Dan Prince was later lost to a storm in the Gulf of Alaska during return tow to the next contract location.

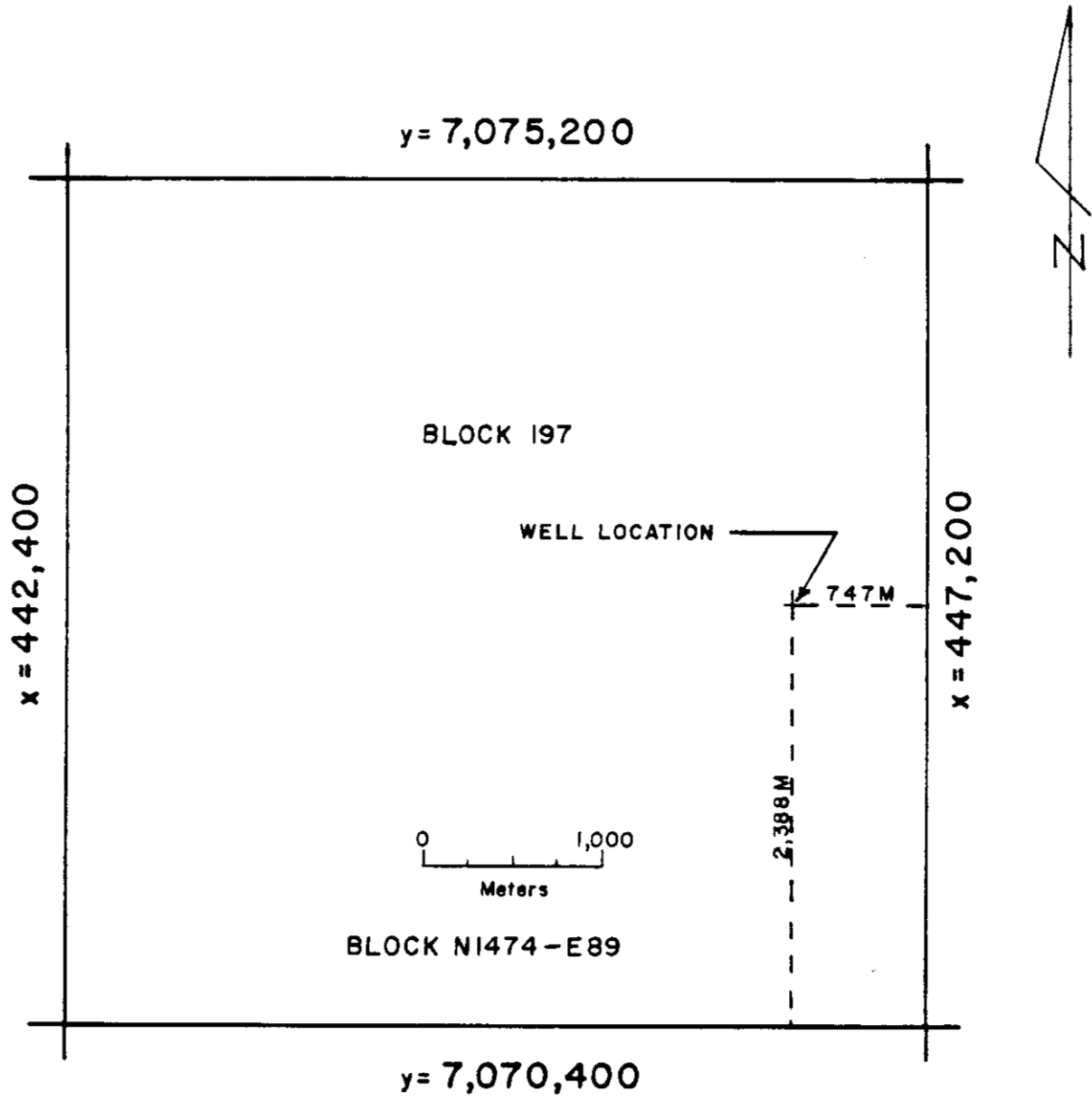

<p>GEODETTIC POSITION</p> <p>LAT. 63° 46' 48.97" N.</p> <p>LONG. 166° 05' 10.40" W.</p>	<p>UNIVERSAL TRANSVERSE MERCATOR COORDINATES, ZONE 3, in METERS.</p> <p>y = 7,072,787.9</p> <p>x = 446,453.5</p>
--	---

Figure 2. Final location plat showing the position of Norton Sound COST No. 1 well.

Drilling Programs

The Norton Sound COST No. 1 well was drilled using one 26-inch drill bit and one 17 1/2-inch bit to drill the 26-inch hole to a depth of 1235 feet. Fourteen 12 1/4-inch bits were used to drill to a depth of 12,175 feet and the well was deepened further with six 8 1/2-inch drill bits to total depth (TD). Additional bits were used for clean-out trips, to drill through cement, and for conventional coring. The daily drilling progress for the well is shown in Figure 3.

Drilling rates ranged from 3 to 1295 feet/hour. The drilling rate averaged 100 feet/hour down to 1250 feet where very soft sandstone was encountered resulting in the maximum rate of penetration for this well. Harder sediments were penetrated after 3500 feet and the drill rate decreased to 100 feet/hour at 7900 feet, 25 feet/hour at 9000 feet, and remained between 10 and 20 feet/hour for the remainder of this well.

Four strings of casing were cemented in the well as shown in Figure 4. The 30-inch casing was set at 294 feet KB and cemented. At 1206 feet, 2040 sacks of Class G cement were used to cement the 20-inch casing. Two thousand and ten sacks of Class G cement were used to cement the 13 3/8-inch casing at 4667 feet. The 9 5/8-inch casing was set at 12,170 feet with 1300 sacks of Class G cement, and the well was open hole below this point.

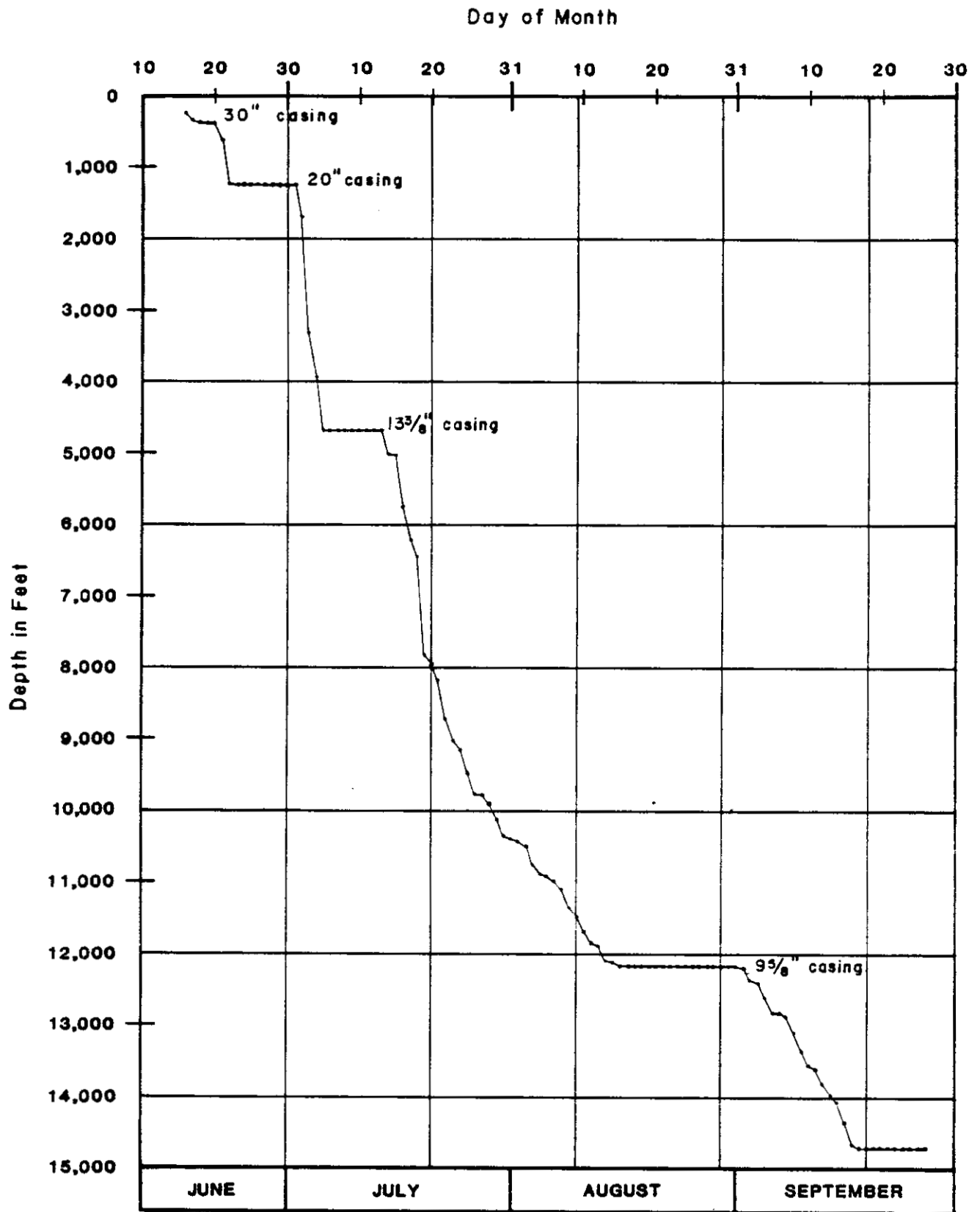

Figure 3. Graph showing daily drilling progress for the Norton Sound COST No. 1 well.

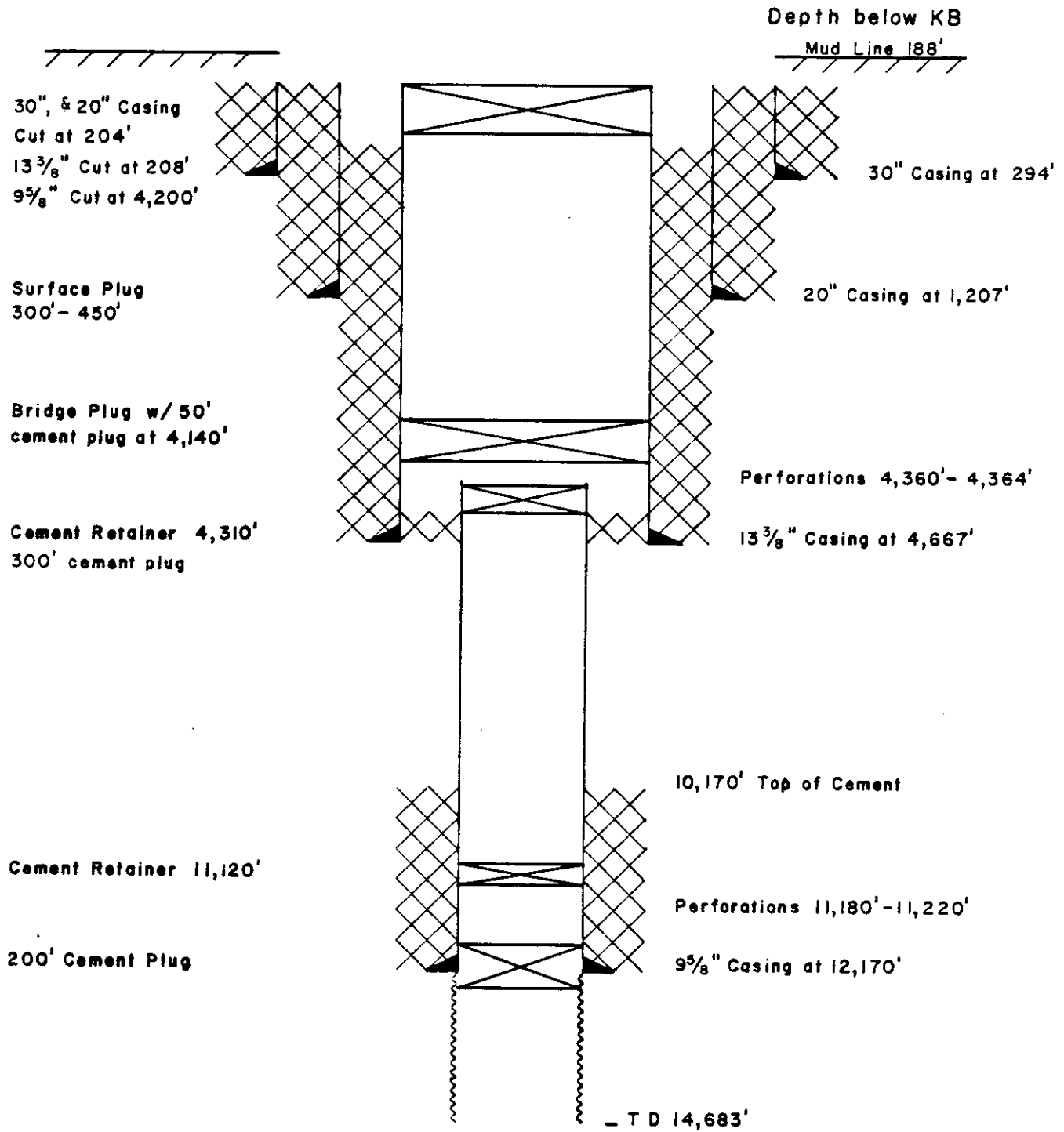

Figure 4. Schematic diagram showing casing strings, plugging, and abandonment program, Norton Sound COST No. 1 well.

Drilling Mud

Selected drilling mud properties and their changes with depth are shown in Figure 5. Sea water was used as drilling fluid for the well to 450 feet where it was replaced by gel and water mud. The initial mud weight was 8.9 pounds/gallon, increasing to 10.0 pounds/gallon at 6250 feet, and remaining at 10.4 pounds/gallon from 12,200 feet to TD. Viscosity varied between 35 and 60 seconds, averaging about 46 seconds. Chloride concentrations began high with 4000 ppm at 450 feet and decreased to as low as 1500 ppm at 5050 feet, while remaining around 2000 ppm for most of the well. Mud pH ranged from 8.5 to 10.8, averaging 10.0. Mud-logging services were provided by The Analysts from 188 feet to TD.

A breakdown of time spent on various activities in the drilling operation is given below:

<u>Operation</u>	<u>Hours</u>	<u>Percent of Total</u>
Rig Up/Tear Down	98	3.1
Towing	446.0	14.5
Drilling	801.5	26.0
Mud Circulation	94.5	3.0
Pickup & Lay Down		
Bottom Hole Assembly	17.0	.6
Hole Opening	53.5	1.7

<u>Operation</u>	<u>Hours</u>	<u>Percent of Total</u>
Reaming	133.5	4.3
Washing	11.5	.4
Short Trips	15.0	.5
Work Stuck Pipe	1.5	0.0
Coring	220.0	7.2
Deviation Surveys	24.0	.8
Fishing	32.5	1.1
Lost Circulation	22.5	.8
Well Control	6.0	.2
Nipple BOP & Rams	55.0	1.8
Test BOP	95.0	3.1
Test Casing	56.5	1.8
Logging	350.5	11.3
Run & Cement Casing	249.0	8.1
Plug & Abandon	153.5	5.0
Drill Cement	33.5	1.1
Drill Stem Test	19.0	.6
Rig Repair and Maintenance	56.0	1.8
Cut Drill Line	8.0	.3
Wait on Orders	4.5	.1
Wait on Weather	3.0	.1
Wait on Crew	1.0	.0
Miscellaneous	2.0	.1
Unallocated Trip	<u>20.0</u>	<u>.6</u>
TOTAL	3083.5	100.0%

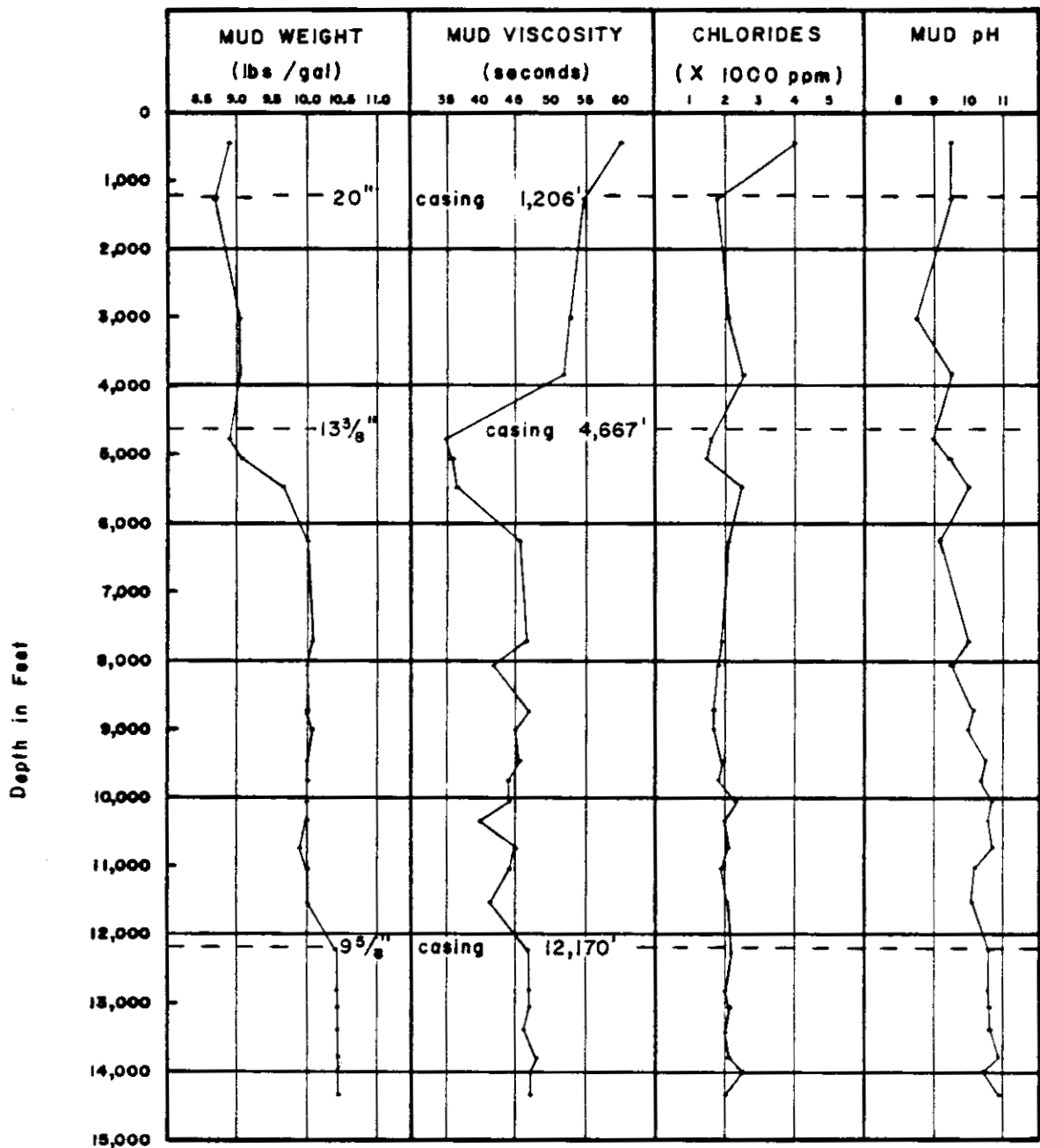

Figure 5. Changes with depth of drilling mud properties, Norton Sound COST No. 1 well, including mud weight, viscosity, total chlorides, and pH.

Samples and Tests

Drill cuttings were collected throughout the well and analyzed for mineral composition and paleontological content. Twelve conventional cores were cut and analyzed for porosity, permeability, and grain density. Core recovery is as follows:

<u>Core No.</u>	<u>Interval (ft)</u>	<u>Recovered (ft)</u>
1	3500-3530	0
2	5008-5028	7.4
3	6220-6250	25.1
4	7938-7968	13.2
5	9750-9760	9.5
6	10,398-10,407	9
7	10,866-10,896	29
8	10,960-10,990	28.9
9	12,070-12,092	21
10	12,389-12,404	14.5
11	13,580-13,610	30
12	14,655-14,683	27.5

Three series of percussion sidewall cores were collected providing a total of 533 samples. In the first series, 117 cores were recovered from 135 attempts at 4670 feet. At 12,175 feet, 330 cores were collected in 360

attempts, and at TD, 86 cores were taken in 90 attempts. The recovery rate was 91 percent.

Logging runs were made at depths of 4670, 12,175, and 14,683 feet. The Borehole Compensated Sonic Log (BHC), Compensated Formation Density Log (FDC) Compensated Neutron Log (CNL) with Neutron Gamma Tool (NGT), Long Spaced Sonic Log (LSS) with Integrated Travel Time (ITT), Proximity Log-Microlog (MPL) Caliper Log, Velocity Survey, and the High-Resolution Continuous Dipmeter (HRT) were recorded on all runs. On the second and third runs, a Dual Induction Laterlog (DIL) was run, and Repeat Formation Tests (RFT) resulting in seven pressure samples were run at 12,175 feet. On the final logging series, three additional logs were run; a Cement bond Log (CBL), a Temperature Survey, and a Micro-Laterolog (MLL).

Two formation tests were made. The first perforated test interval was 11,180-11,220 feet and no formation fluid was recovered. Three samples of formation fluid were recovered on the second test done through the perforated interval 4360-4364 feet.

Weather

Rig down time owing to weather consisted of a total of 3 hours, only 0.1 percent of total rig time.

SHALLOW GEOLOGIC SETTING
NORTON SOUND COST NO. 1 WELL

By David Steffy

Shallow geologic characteristics of the drill site were identified in a survey conducted by Tetra Tech, Inc., in 1979. The survey, part of the permit to drill application, included a geotechnical study of the upper 25 feet of sediment and a high-resolution seismic-reflection survey of the seafloor and its near-surface features. The regional description of Norton Sound is based on five U.S. Geological Survey maps prepared as part of the prelease investigation of the surface and near-surface geologic environment of Norton Sound (Hoose, Steffy, and Lybeck, 1981; Steffy and Hoose, 1981; Steffy and Lybeck, 1981; Steffy, Turner, and Lybeck, 1981; Steffy, Turner, Lybeck, and Roe, 1981).

Bathymetry

Norton Sound is a flat-bottomed embayment of the northeastern Bering Sea epicontinental shelf. Water depths in the OCS Sale 57 area range from 16 to 89 feet. The sale area covers part of the Yukon River delta front and prodelta, which are separated from the prograding shoreline by a subice platform (Larsen, Nelson, and Thor, 1980). This platform is 3 to 12 miles wide along the southern boundary of the sale area and occurs in water depths of less than 32 feet. COST

No. 1 well is located in the Yukon prodelta in 90 feet of water. The delta front is the seaward extension of Holocene, nearshore sand deposits and is characterized by a 1- to 2-degree seaward sloping seafloor. Seaward, the front becomes the prodelta, a very gently sloping area that marks the edge of deltaic sedimentation. In the sale area the prodelta slopes less than 1 degree and is 52 to 89 feet deep.

Sea-floor Geology

The sea-floor topography of the Norton Sound area is the result of interactions of wind, water, ice, and sedimentation processes. Surface sediments range in size from fine sand at the delta front to sandy silt and silt in the prodelta area. These unconsolidated sediments are continually reworked by ice gouging, current scour, storm surging, and release of biogenic gas. The seafloor in the vicinity of the number 1 and number 2 wells is essentially similar and both are discussed in this section.

Single-keeled and multikeeled ice floes driven by wind and water currents furrow the seafloor parallel to the bathymetric contours. These furrows occur in water depths down to 79 feet, and are most dense between depths of 32 and 56 feet. The No. 2 well is located in a relatively intense ice-gouging zone caused by the westward-moving ice pack of Norton Sound shearing against the shorefast ice that extends offshore from the delta. The single-keeled ice gouges identified by side-scan sonar range in width from 16 to 164 feet and are seldom greater than 3 feet deep. Active sedimentation infills the gouges in the river-dominated months of summer.

Transient features such as current scour, megaripples, and longitudinal current lineations were not found at the drill sites, but were found in a limited extent east of the No. 2 well and just west of the delta. Current scour is characterized by elongated depressions 330 to 490 feet long, 115 to 330 feet wide, and less than 6 feet deep. They parallel the dominant bottom-current direction and rework the unconsolidated silty fine sand comprising the local surface sediments. Megaripples occur as a series of ripples with a wavelength of 65 to 165 feet and an amplitude of less than 1.5 feet. They occur in a subtle bathymetric trough north of the No. 2 well, and their crests are normal to the dominant westward bottom-current direction. Longitudinal current lineations occur as a series of furrows with wavelengths of 30 to 100 feet and depths of less than 1.5 feet. These lineations parallel the dominant bottom-current direction and occur just south of the megaripples.

Degassing of biogenic gas generated by buried Holocene peat layers results in gas cratering in the eastern half of Norton Sound. The cratering is usually less than 1.5 feet in relief and on side-scan sonograms appears as a patchy textural feature.

Quaternary Geology

Norton Sound was subaerially exposed in the late Pleistocene owing to a lowered sea level. Quaternary sediments consist of fluvial deposits of clayey silt to silty sand with varying amounts of wood fragments, shells, and organic

matter. About 10,000 to 9500 yr B.P., the sea transgressed over Norton Sound and began reworking and burying tundra peat deposits (Nelson, 1980). These organic deposits represent a sea-level stillstand 60 to 80 feet below present sea level and are the base of the Holocene. Transgression resulted in Holocene deposits ranging from fine sand in the northern half of the sale area to clayey silt near the Yukon Delta. Approximately 32 to 40 feet below present sea level, a younger, less extensive, organic-rich layer extends seaward from the Yukon Delta. This represents a later stillstand that allowed the development of tundra peat. Subsequent transgression over the area reworked and buried the peat resulting in an organic-rich silt deposit. This deposit grades upward into clayey silt in the west and silty sand in the east. The buried organic-rich deposits are currently generating gas as indicated by the gas cratering and by extensive, shallow acoustic anomalies that occur on both the processed and analog records of the minisparker and watergun systems.

SEISMIC REFLECTION CORRELATION
AND
VELOCITY ANALYSIS

by David Steffy

By the use of velocity information from the Norton Sound COST Nos. 1 and 2 wells and a 1978 seismic reflection survey by the U.S. Geological Survey (fig. 6), seismic correlations and velocities from the two wells were compared to each other and to those from the nearby seismic lines. The stacking velocities used on the common-depth-point (CDP) traces were evaluated before stacking the gathers. These comparisons were used to assign geologic significance to features identified on the profiles, and the significant features were used to establish the geologic history of the Norton Basin in the concluding section of this report.

Seismic Reflection Correlation

A synthetic seismogram was produced by use of the borehole-compensated, interval-transit-time log of the No. 1 well (fig. 7). The sonic log was visually averaged while being stream digitized and was measured to the nearest foot in depth and the nearest microsecond/foot in transit time. This resulted in log samples being taken at irregular intervals. However, the sampling was frequent enough to prevent aliasing in the seismogram. The digitized data were then entered into a computer program that produced a synthetic seismogram

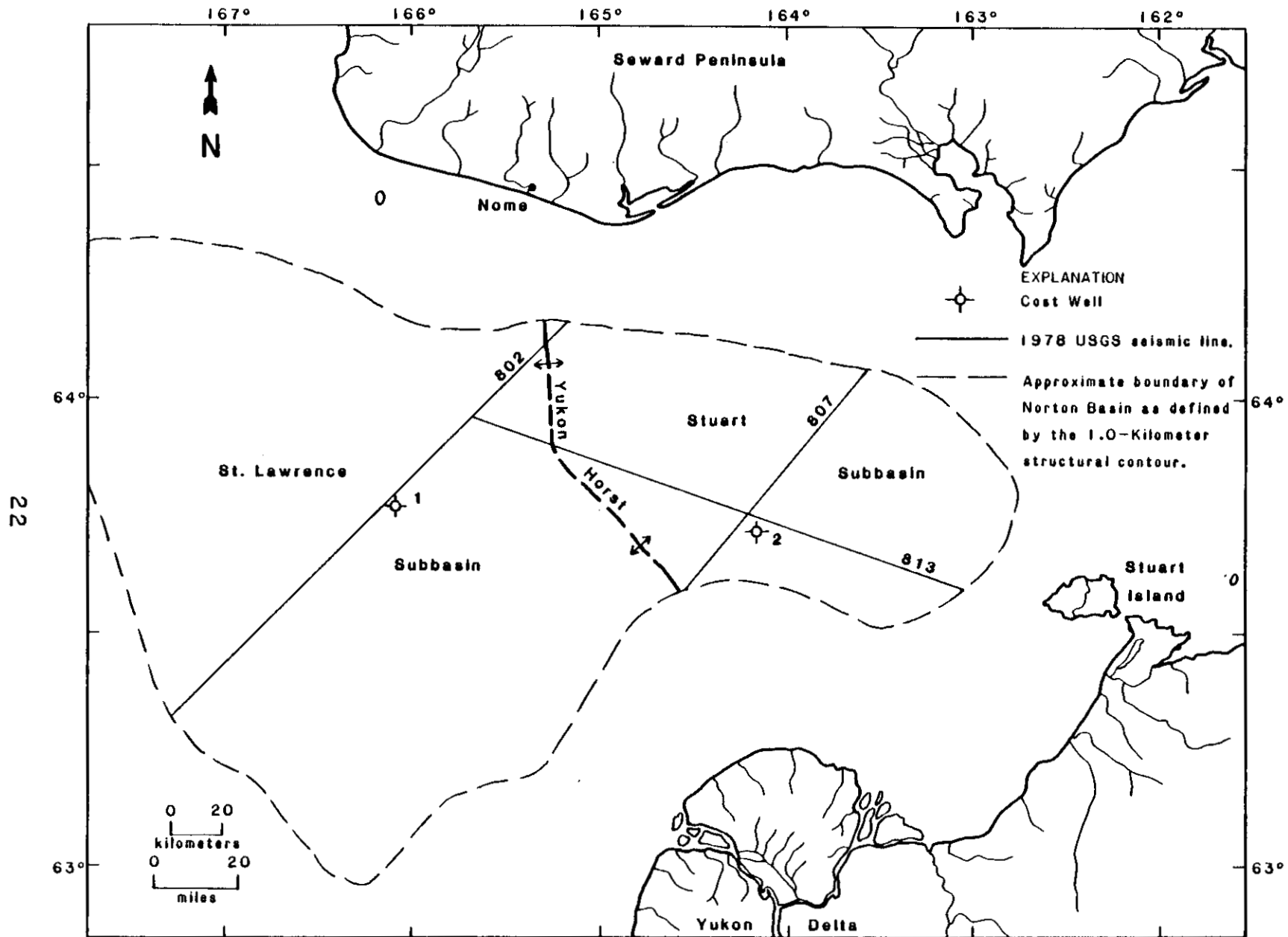
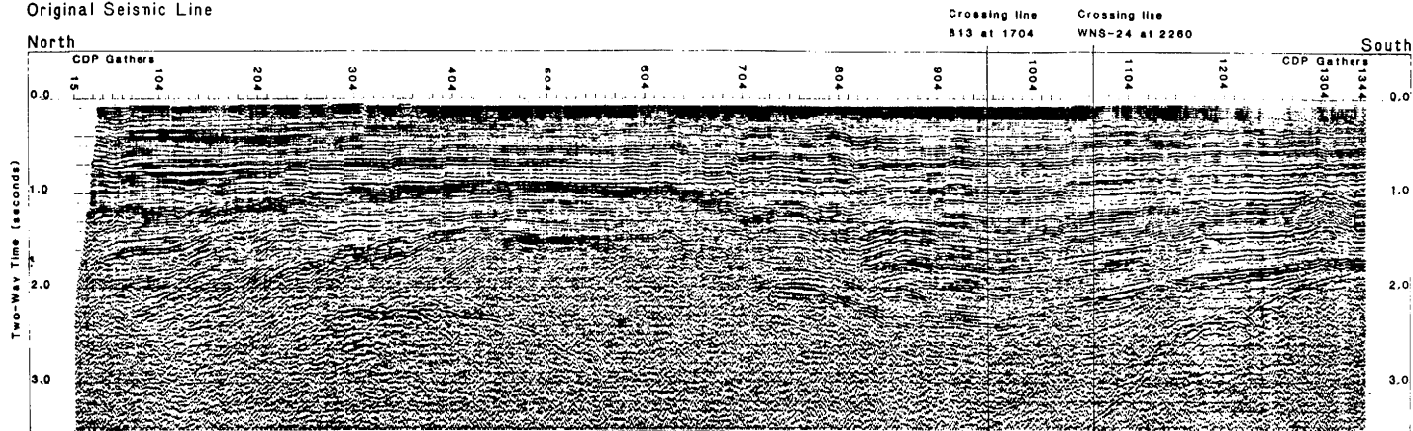

Figure 6. Location map of Norton Basin, COST Wells, and USGS seismic lines. Adopted from Fisher and others (1980).

without multiples. Constant density was assumed, therefore density was not incorporated into the calculation of the reflection coefficients. This assumption apparently does not adversely affect the results of the synthetic seismogram in a simple geologic setting (Sheriff, 1978). The computer program also assumes a series of horizontal, parallel earth layers with an elastic constant, and assumes that the incident waves are normal to the reflecting surface and have planar wavefronts. The calculated reflection coefficients were then convolved with a standard ricker wavelet having a frequency range of 8-55 Hz. This convolution results in a seismogram that is displayed with both normal and reverse polarity.

The synthetic seismogram was then correlated to the 1977 Western Geophysical seismic line WNS-38 which profiles through the location of the No. 1 well (fig. 7). By use of this correlation, four distinct horizons are identified in order to represent the structural and stratigraphic configuration of the basin. Three of the four horizons are continuous to the No. 2 well, where a similarly derived synthetic seismogram was used. Figures 8, 9, and 10 are USGS seismic lines 807, 813, and 802, respectively, which were surveyed near the wells and display these horizons. Line 807 is a north-south profile through the Stuart subbasin. The line profiles within one mile of the No. 2 well at CDP gather 1004. Line 802 is a north-south profile through the St. Lawrence subbasin. The line profiles within one mile of the No. 1 well at CDP gather 2240. Line 813 is an east-west profile across the Stuart subbasin, the Yukon horst, and the St. Lawrence subbasin. The line profiles within 4 miles of the No. 2 well and within 16 miles of the No. 1 well at CDP gathers 1740 and 120, respectively. Figure 11 displays the time-stratigraphic column of the

Original Seismic Line



Interpreted Seismic Line

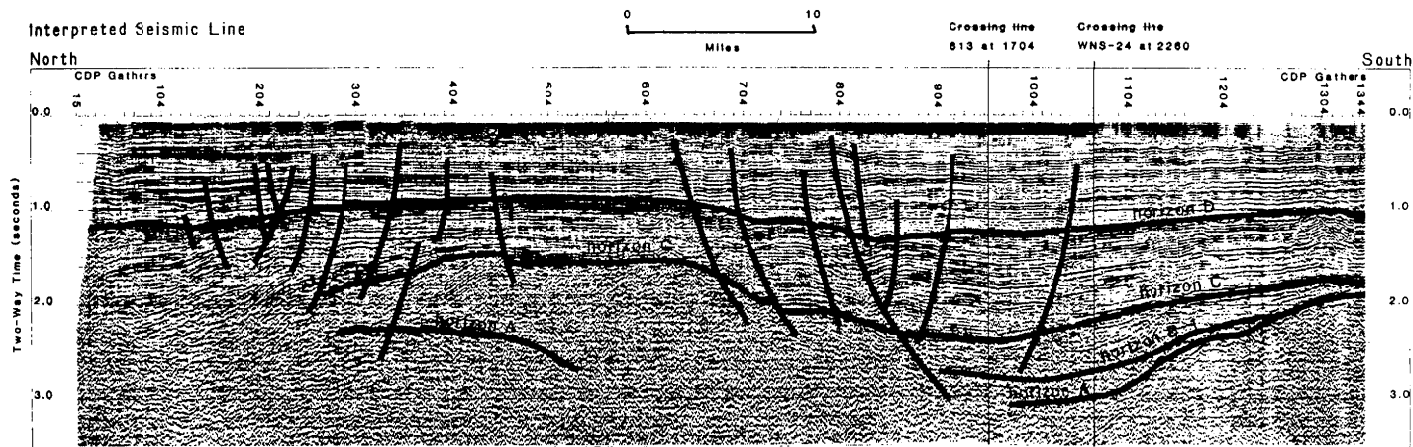

Figure 8. USGS Seismic Line 807.

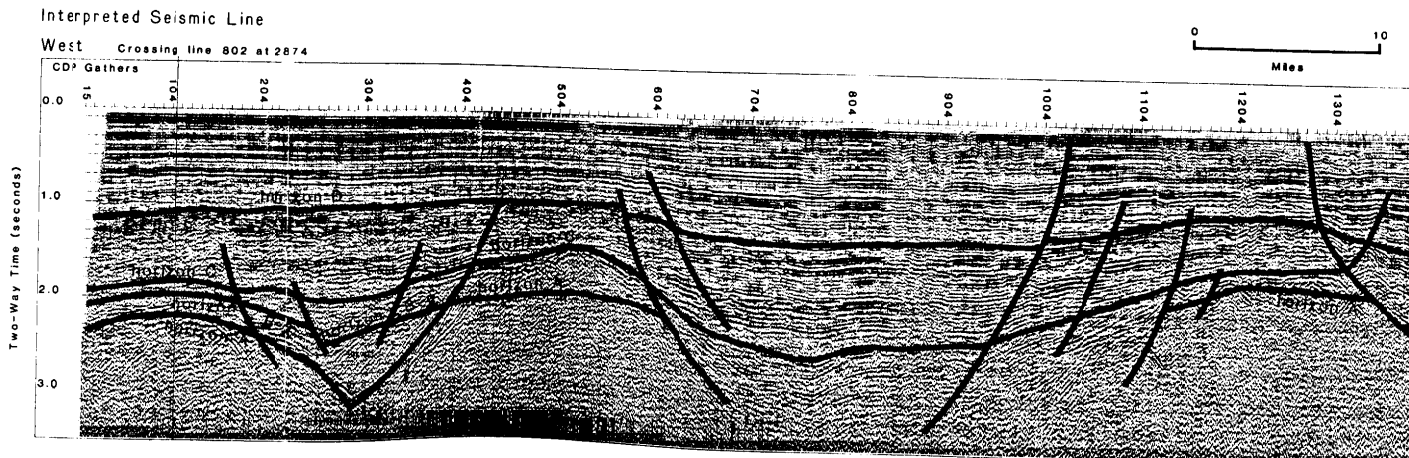
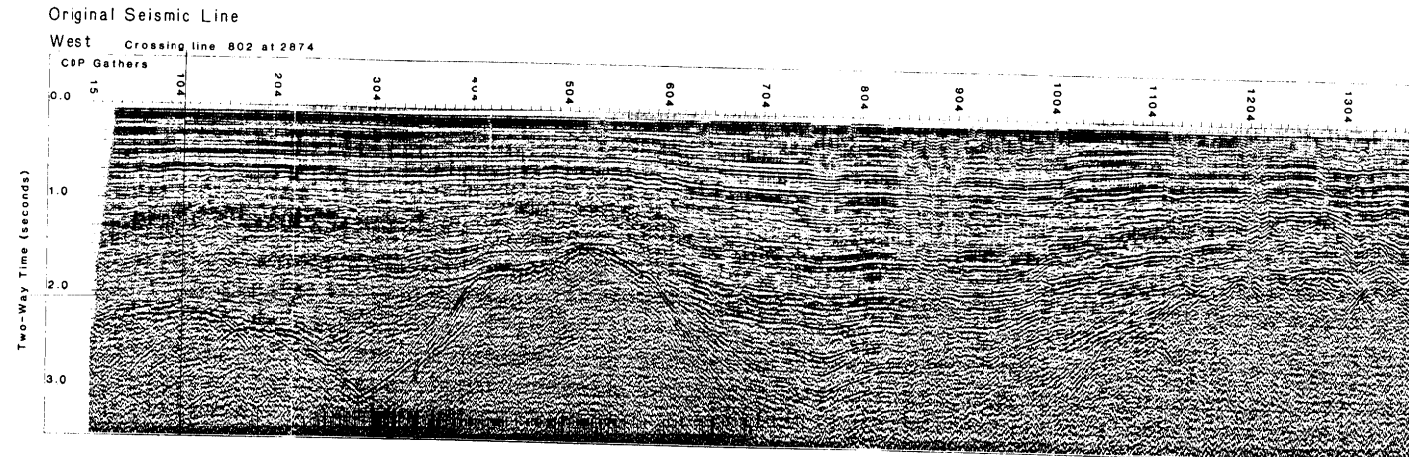
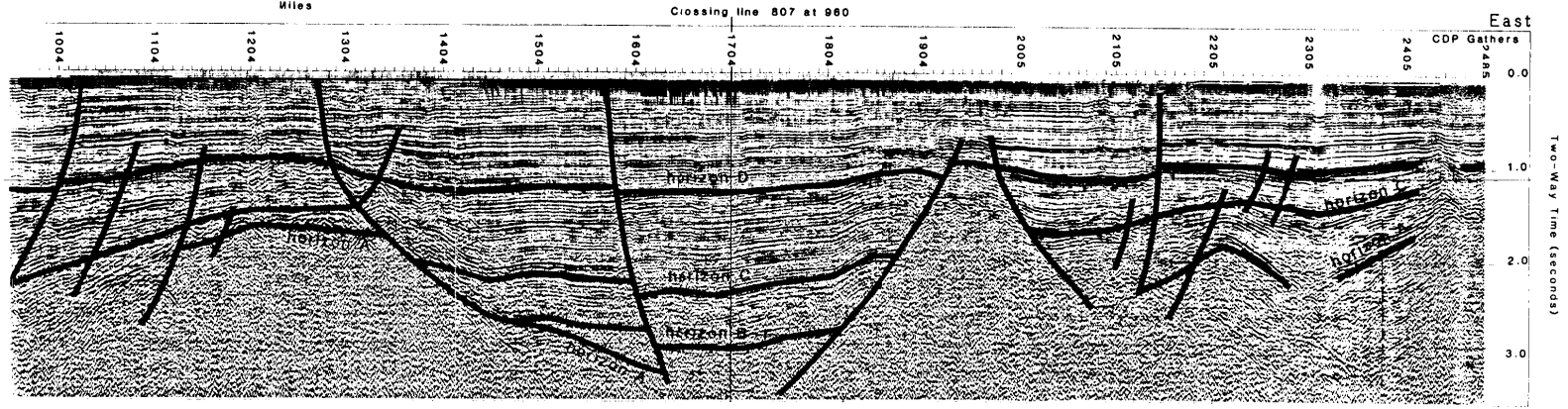
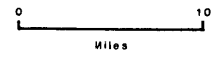
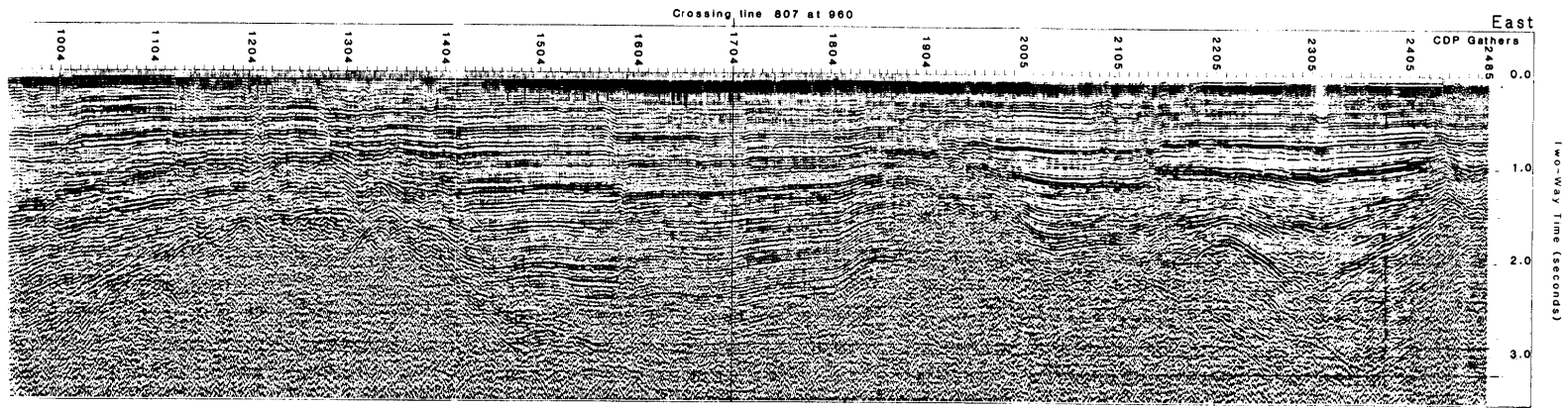
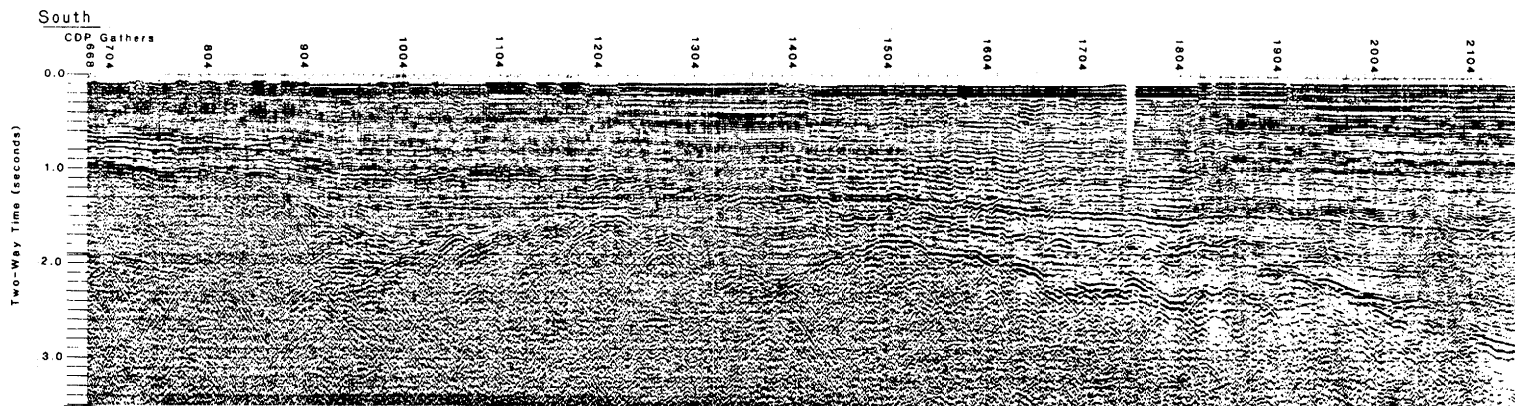

Figure 9. USGS Seismic Line 813.



Original Seismic Line



Interpreted Seismic Line

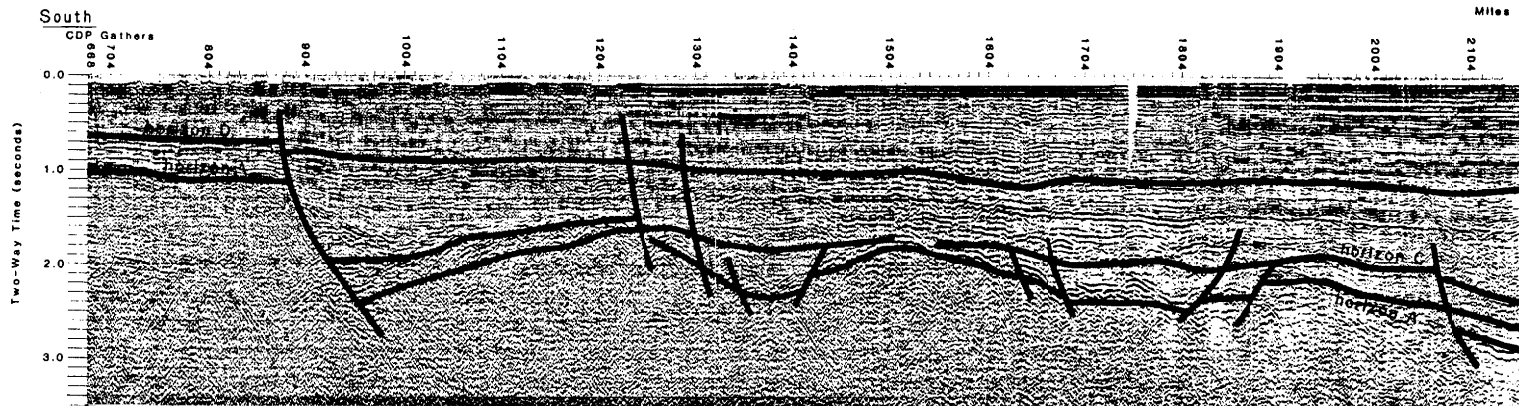
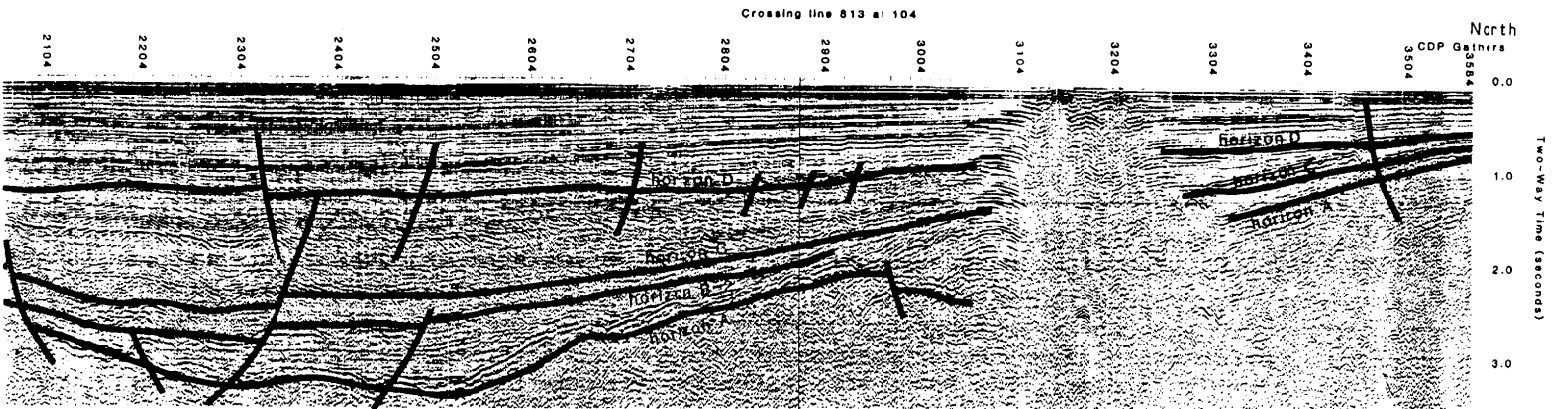
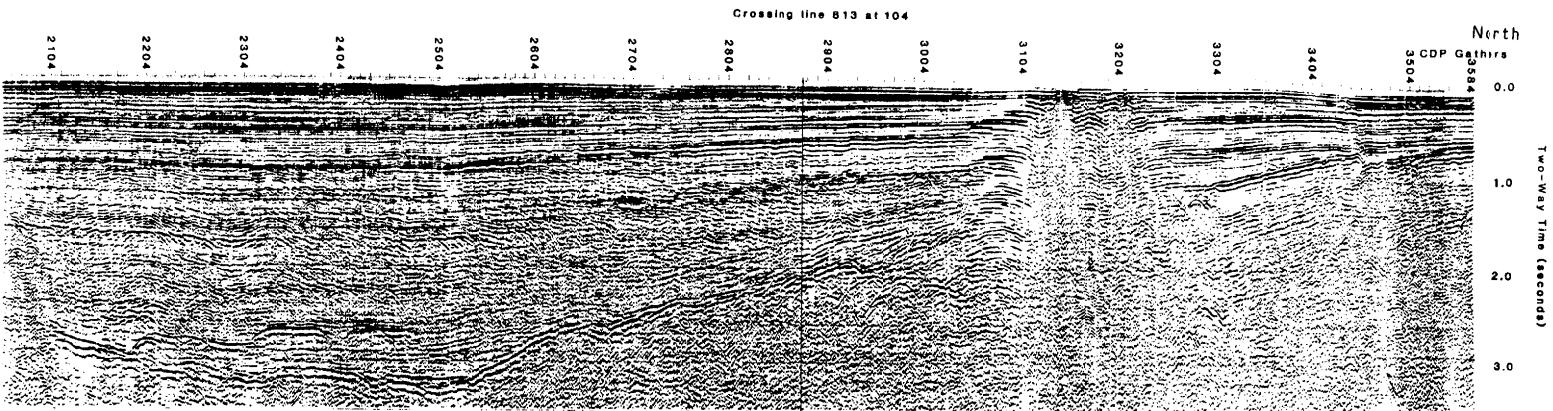

Figure 10. USGS Seismic Line 802.



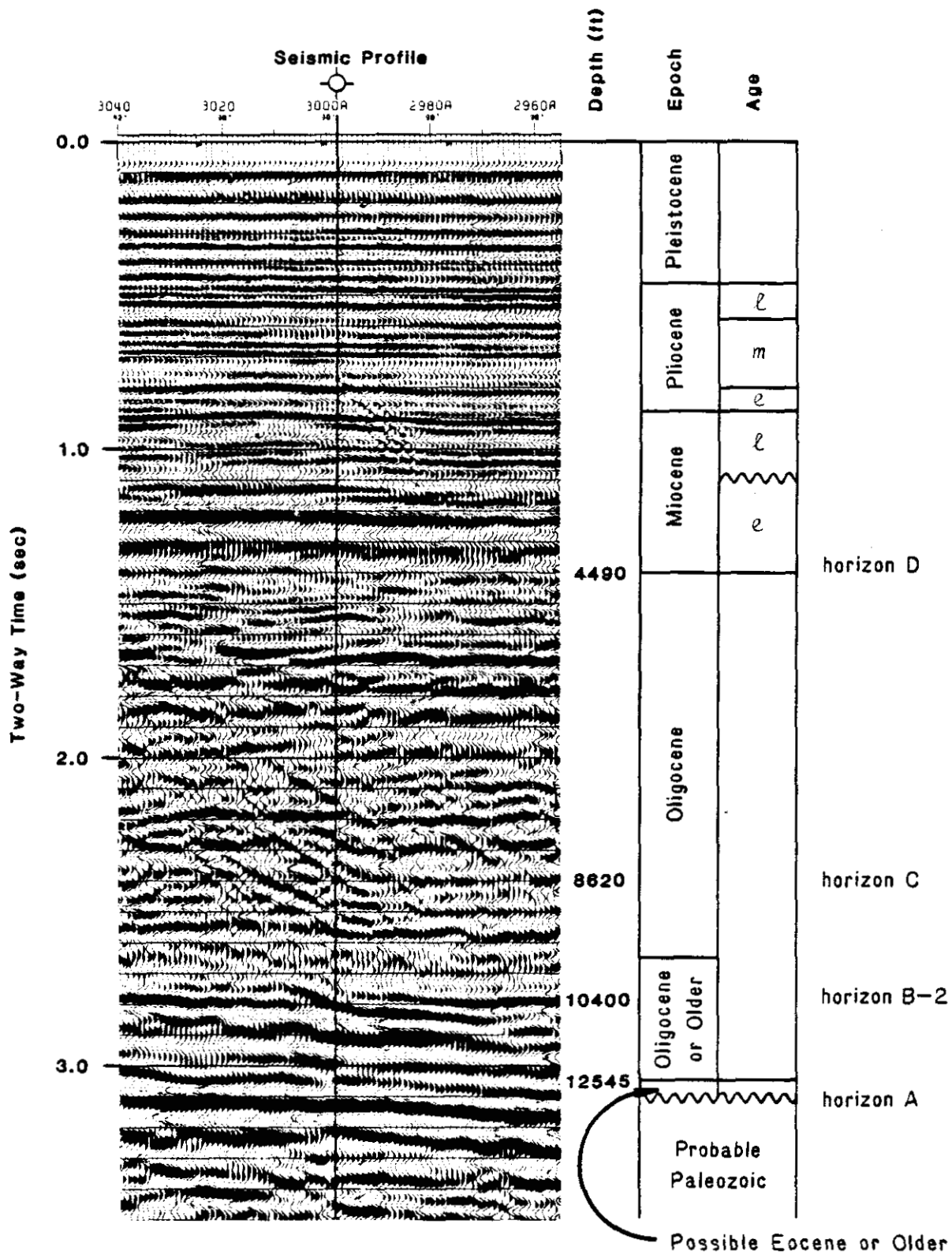

Figure 11. Time-stratigraphic column and seismic profile of COST Well 1.

No. 1 well based on the interpretation described in the Paleontology and Bio-Stratigraphy section of this report. Lithologic correlations of the horizons are based on the descriptions in the Lithology and Geophysical Log Interpretation section.

Horizon A occurs at 3.10 seconds or 12,550 feet in the No. 1 well, and at 3.57 seconds or 14,460 feet in the No. 2 well. The horizon is characterized by large amplitude, low frequency reflections that are mostly discontinuous. Below the horizon there are few areas in the basin where reflections occur. Above the horizon the reflections display an onlap relationship. The horizon represents an unconformity that separates the base of the basin fill from the underlying Paleozoic (?) metamorphic basement rock. Horizon A is correlated between the wells and displays major structural deformation of an early Tertiary to late Mesozoic erosional surface. This deformation initiated the subsidence of the St. Lawrence and Stuart subbasins. During the subsidence, their common border, the north-south trending Yukon horst, was a relatively high basement feature (fig. 9). Normal faulting delineates the structural depressions within the subbasins, and the Yukon horst. Some of these faults were active into the Pleistocene and probably the Holocene (Hoose, Steffy, and Lybeck, 1981). Normal faults with displacements of over 4500 feet offset horizon A. Downwarping of the horizon allowed over 14,000 feet of sedimentary fill to accumulate in the Stuart subbasin.

Horizon B-1 occurs at 3.12 seconds or 12,700 feet in the No. 2 well. The horizon is characterized by large amplitude, low frequency reflections. There are few reflections just below the horizon, and those that do occur have

variable amplitude and are discontinuous. This horizon is an apparent unconformable surface that onlaps horizon A at structural highs and reflects syndepositional subsidence and faulting. Horizon B-1 is neither continuous throughout the Stuart subbasin nor correlated to any specific horizon in the No. 1 well. At the No. 2 well, the horizon defines the top of an Eocene coal-sandstone sequence that is bounded at the bottom by horizon A.

Horizon B-2 occurs at 2.78 seconds or 10,400 feet in the No. 1 well. At the well, the horizon is defined by large amplitude, low frequency reflections that are laterally discontinuous. The reflections eventually become undiscernible but appear to onlap Horizon A. This horizon is neither continuous throughout the St. Lawrence subbasin nor correlated to any specific horizon in the No. 2 well. The horizon does show evidence of contemporaneous subsidence and offset by basement controlled faulting. At the well, the horizon is correlative with an Oligocene or older basalt sequence (flows or hypabyssal). Lateral changes in the Oligocene or older reflections that define the top of this igneous-sedimentary sequence indicate that these units probably grade into sedimentary deposits of equivalent age.

Horizon C occurs at 2.41 seconds or 8620 feet in the No. 1 well, and at 2.33 seconds or 8,500 feet in the No. 2 well. In this Stuart subbasin, this horizon is the boundary between a deeper zone of smaller amplitude, discontinuous reflections and a shallower zone of larger amplitude, continuous reflections. Both zones of reflections are conformable to horizon C in the basin and thin towards structural highs where they onlap horizons B-1, B-2, and A. Horizon C

is continuous throughout the basin and is correlated to the No. 1 well. In the St. Lawrence subbasin, this horizon is not as distinct as it is in the Stuart subbasin east of the Yukon horst. Both the deep and shallow zones of reflections in the St. Lawrence subbasin are more discontinuous and have smaller and more variable amplitudes than their equivalents east of the Yukon horst. Throughout the basin, the horizon shows syndepositional subsidence and faulting and pinches out at some structural highs, including the Yukon horst. At the No. 1 well the horizon correlates with a shelfal marine mudstone, shale, and interbedded sandstone sequence. At the No. 2 well, this horizon is correlated to the boundary between an overlying marine sandstone and an underlying coal-sandstone sequence.

Horizon D occurs at 1.42 seconds or about 4,490 feet in the No. 1 well, and at 1.18 seconds or 3,490 feet in the No. 2 well. Throughout the basin, this horizon separates a deeper zone of large amplitude, high frequency, continuous reflections from a shallower zone of small amplitude, discontinuous reflections. The horizon is a conformable surface throughout the basin and is correlative with a late Oligocene coal-sandstone sequence. The horizon is commonly offset by normal faults that are younger than horizon C.

Velocity Analysis

RMS velocities, interval velocities, and a time-depth curve were calculated (figs. 12 and 13) using the interval-transit-time log of the No. 1 well. A

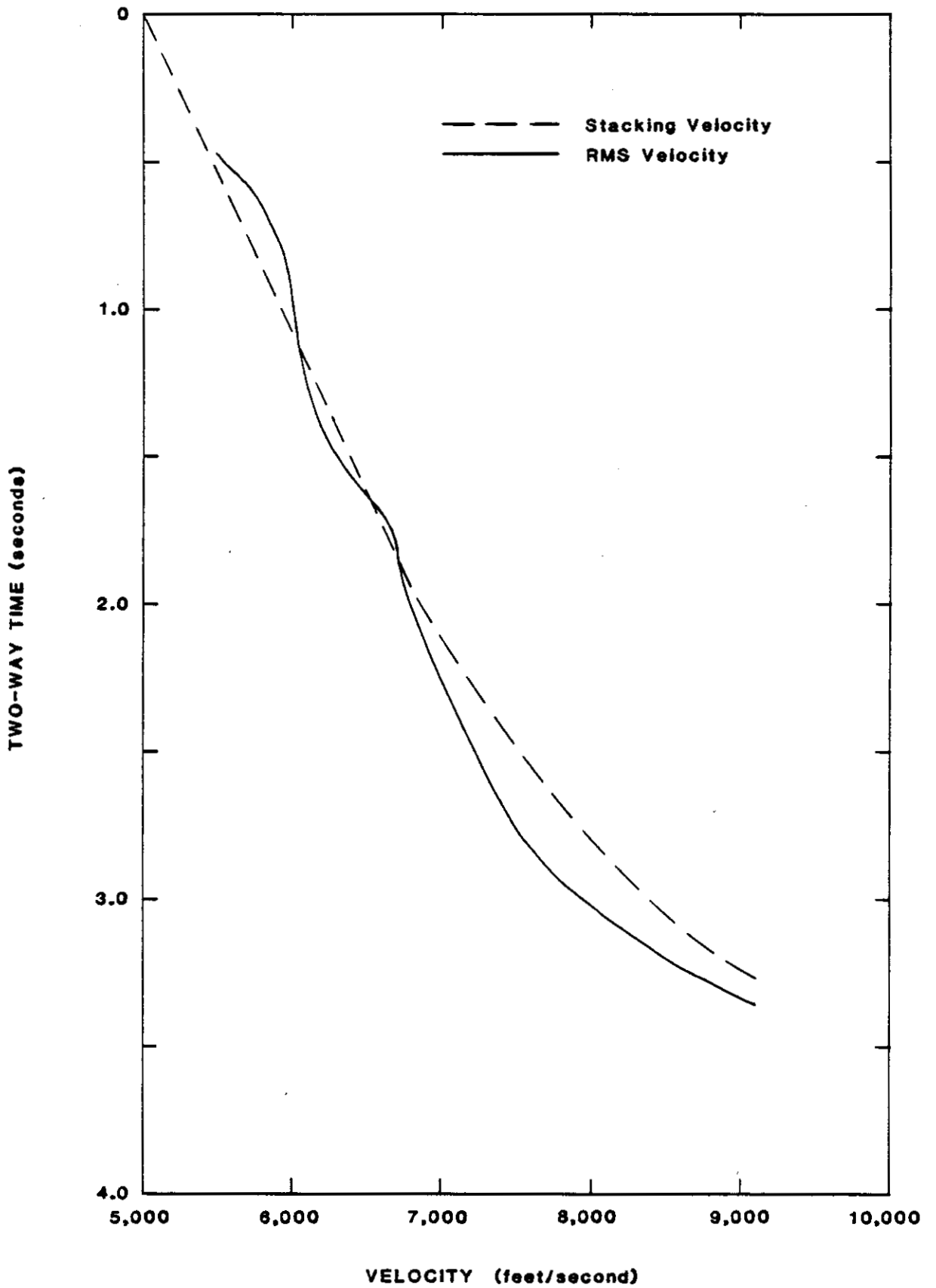

FIGURE 12 -COMPARISON BETWEEN STACKING VELOCITIES AND RMS VELOCITIES FOR COST WELL NO. 1

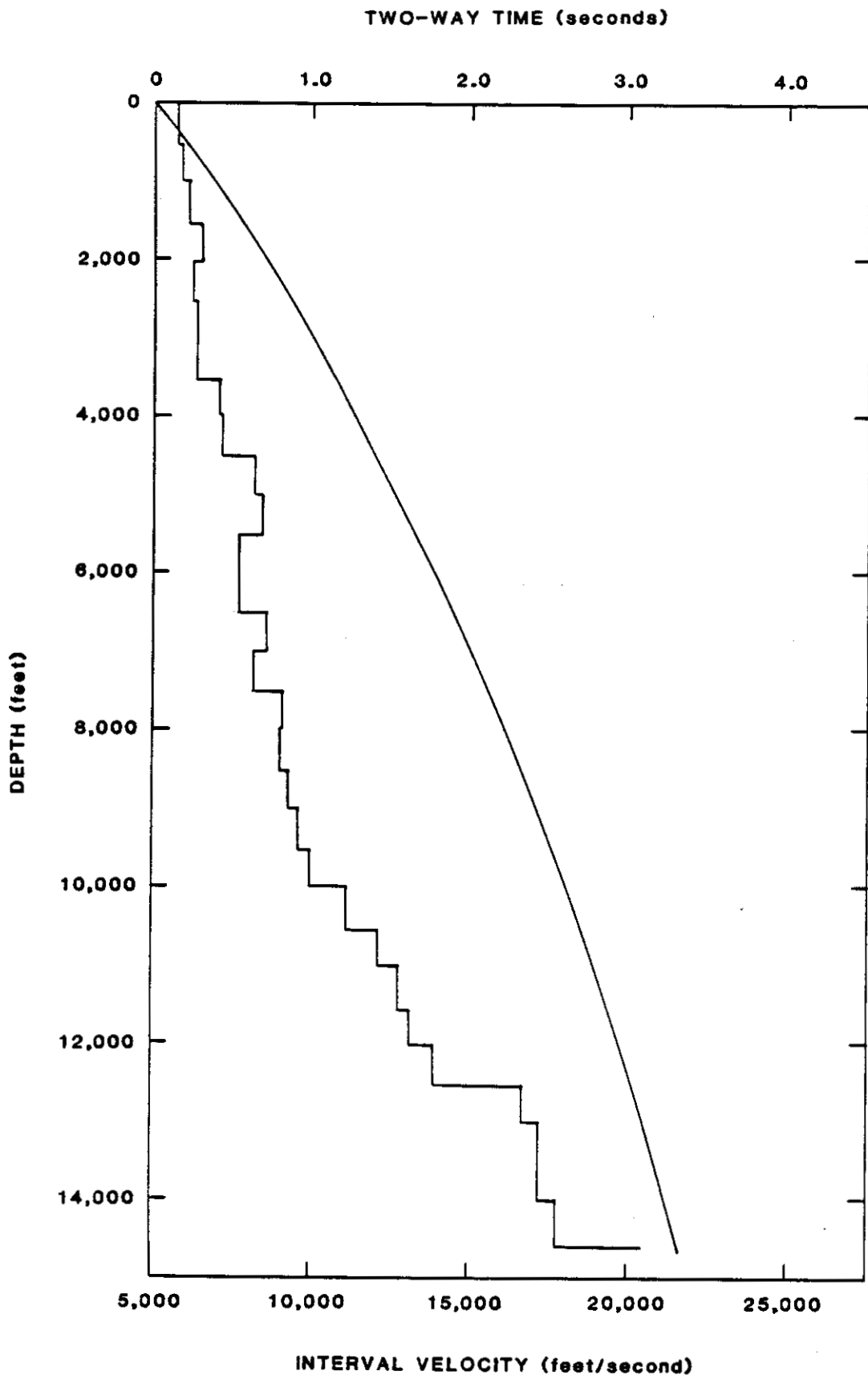

FIGURE 13 - INTERVAL VELOCITIES AND TIME-DEPTH CURVE FROM SONIC LOG OF COST WELL NO. 1

comparison is made between these and similar velocities and a time-depth curve that were calculated from nearby seismic reflection data.

In flat-lying parallel-bedded strata, the RMS velocities derived from a sonic log are comparable to the stacking velocities that are used to correct for normal movement of CDP traces. Figure 12 displays this comparison. Stacking velocities for USGS lines 802 and 009 that were shot within 5 miles of the well were picked and averaged. Down to 1.85 seconds or 6,100 feet, the two types of velocities are in good agreement. Below 1.85 seconds, the stacking velocities become increasingly higher than the RMS velocities. Anstey (1977) points out that stacking velocities and borehole velocity findings might not agree because of geometric and nongeometric differences in the data collection methods. In this case, the difference below 1.85 seconds is partially explained by dipping reflectors. Reflections with dips of up to 19° are present where some of the velocity spectra are displayed.

After adjusting the stacking velocities for dip, interval velocities and a time-depth curve were calculated (fig. 14). Down to 10,500 feet, these interval velocities are in close agreement with those calculated from sonic data (fig. 13). Below 10,500 feet, the interval velocities derived from seismic reflection data are consistently higher than those derived from sonic data. This difference in interval velocities causes a divergence in their corresponding time-depth curves (fig. 15). The difference is probably due to geometric and nongeometric differences in data collection methods.

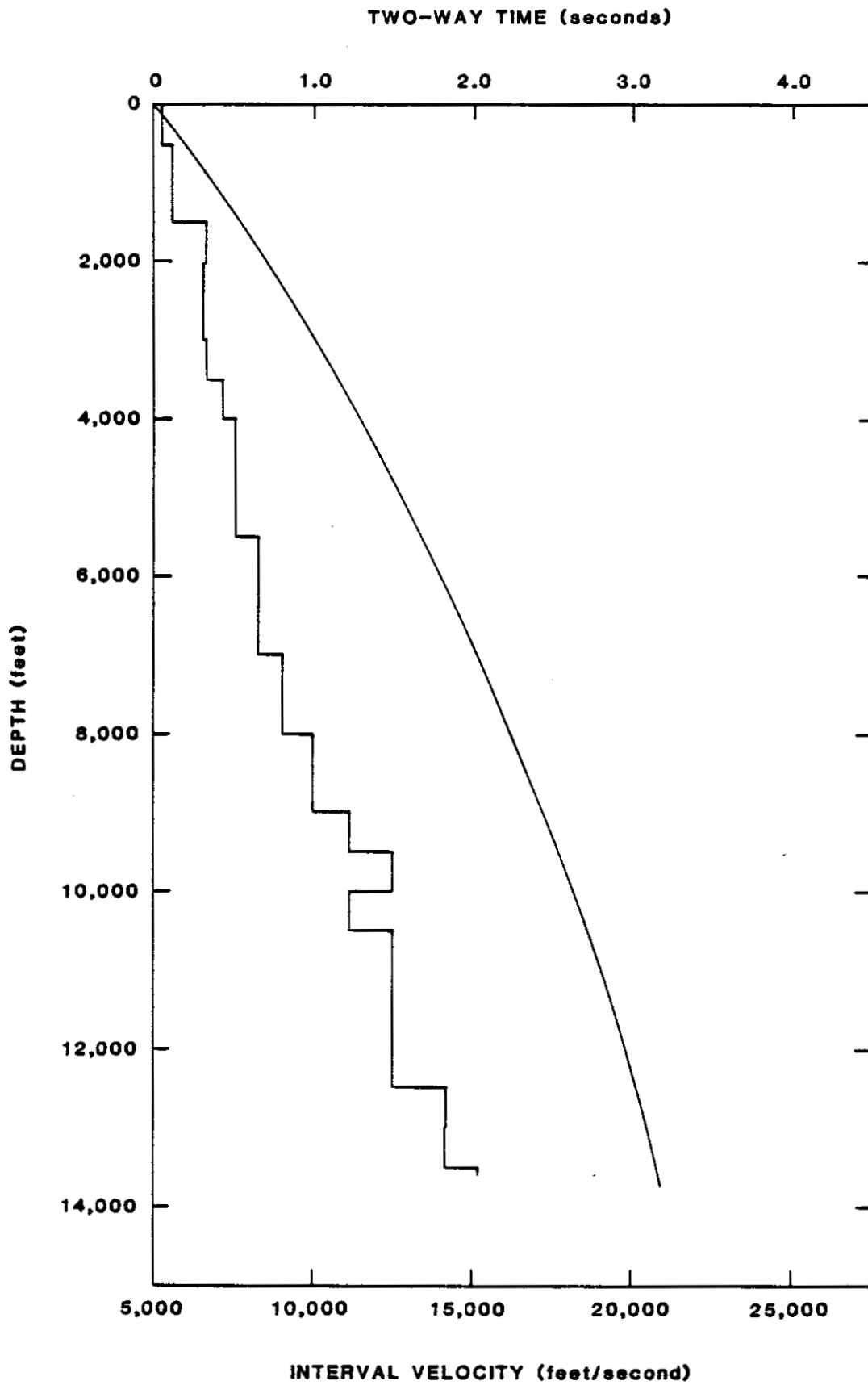

FIGURE 14 -INTERVAL VELOCITIES AND TIME-DEPTH FROM SEISMIC DATA NEAR COST WELL NO. 1

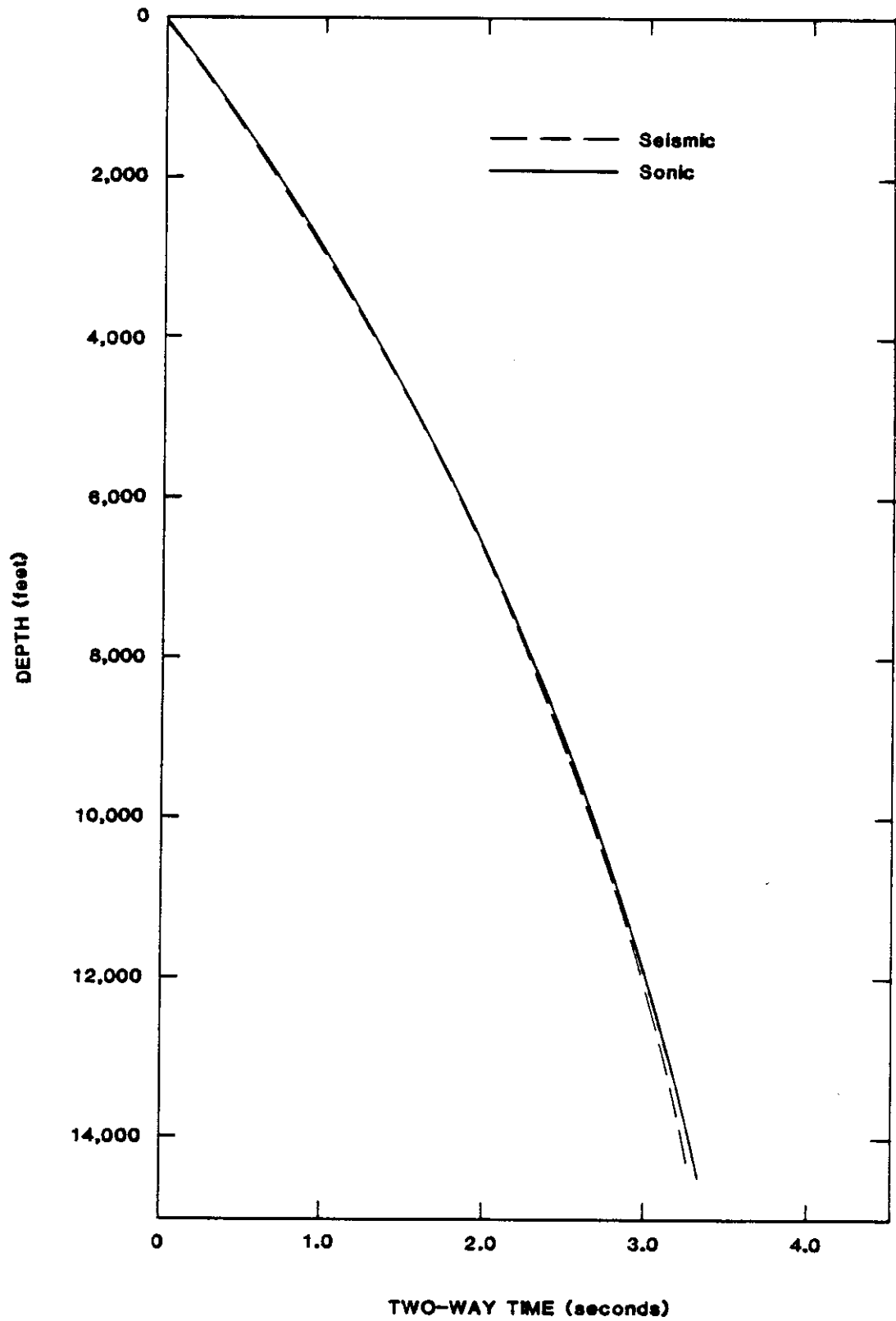

FIGURE 15 - COMPARISON BETWEEN TIME-DEPTH CURVE DERIVED FROM SEISMIC AND SONIC DATA FOR COST WELL NO. 1

Figure 16 is a comparison of the time-depth curves derived from seismic reflection data collected near the wells. Down to 5,000 feet the curves are in good agreement. Below 5,000 feet, the No. 2 well displays a steeper time-depth curve. These higher velocities are probably due to lithologic differences in the wells between 5,000 and 10,000 feet. In this interval, the No. 2 well penetrated a coal-sandstone sequence that has a higher average interval velocity than the marine sediments found in the No. 1 well. From 10,000 to about 12,550 feet, the interval velocities are approximately the same. Below 12,550 feet, interval velocities in the No. 1 well reflect an acoustic basement of metamorphic rock, whereas interval velocities in the No. 2 well reflect a relatively lower velocity coal-sandstone sequence down to a depth of 14,460 feet. Below 14,460 feet the interval velocities reflect the metamorphic rock of acoustic basement. Therefore, any time-depth conversions should consider the lithologic differences in the wells below 5,000 feet. The differences probably reflect the individual subbasin histories. Below 5000 feet velocity variations within each subbasin probably will not be as great as velocity variations between the subbasins.

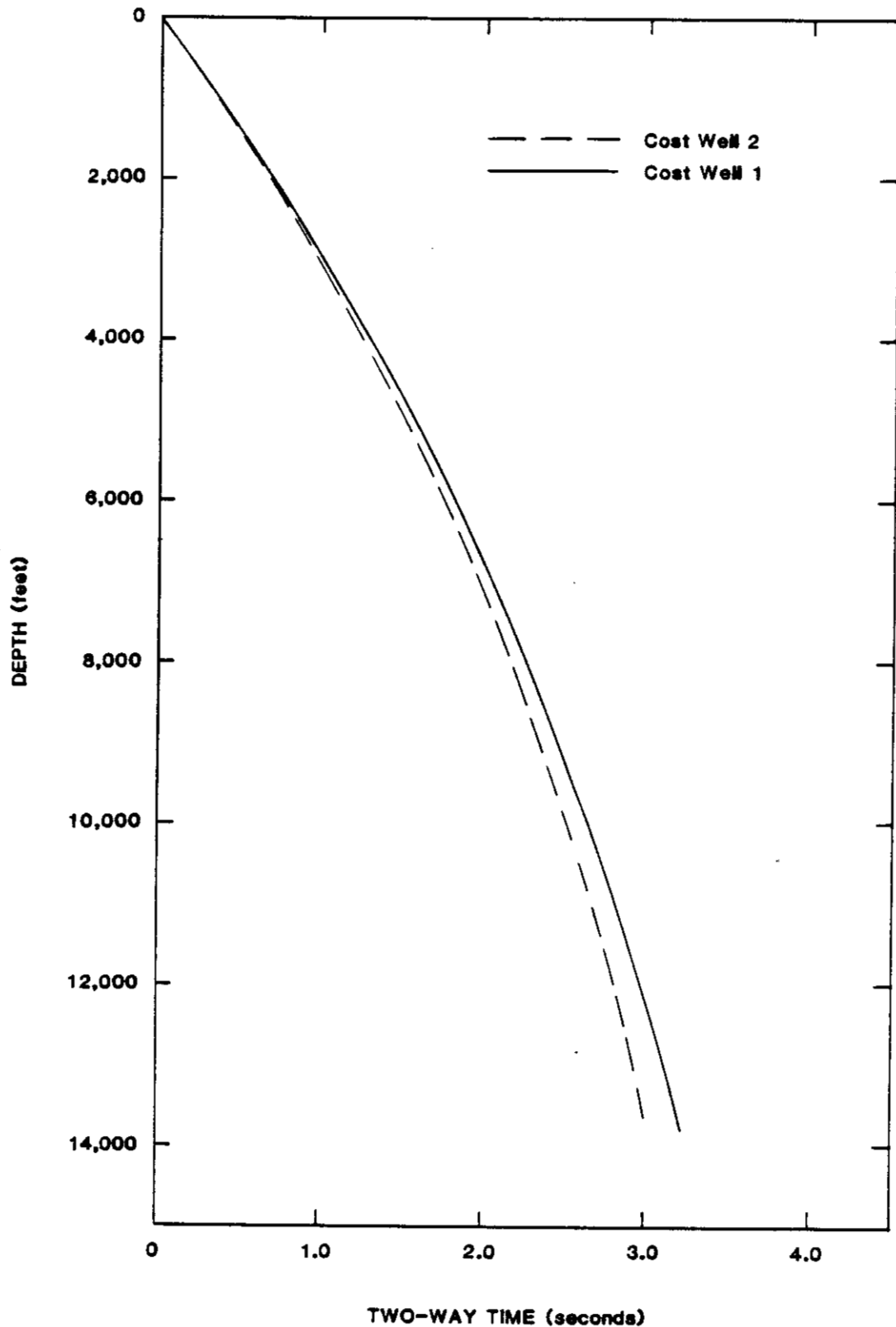

FIGURE 16 - COMPARISON BETWEEN TIME-DEPTH CURVES FOR COST WELLS 1 AND 2

PALEONTOLOGY AND BIOSTRATIGRAPHY

by

Ronald F. Turner

Paleoecologic and biostratigraphic determinations in the ARCO Norton Sound COST No. 1 Well are based on detailed analyses of microfossil assemblages containing Foraminifera, silicoflagellates and diatoms, calcareous nannoplankton, and marine and terrestrial palynomorphs. Rotary drill bit cuttings were examined at 30-foot intervals from the first sample at 180 feet to the total depth of 14,683 feet. Data from conventional and sidewall cores were also examined and utilized. In addition, slides, processed samples, and reports prepared for the participants by consultants were examined, interpreted, and integrated into this report (Appendix). Discrepancies between Minerals Management Service and consultant interpretations, principally the location of biostratigraphic tops, for the most part can be attributed to sample content variations and differences in sample preparation techniques. Foraminiferal analysis, interpretation, and synthesis of other data were done by the author. Siliceous microfossil analysis was done by Donald L. Olson.

Strata are discussed in the order that they were penetrated. The biostratigraphic units delineated represent a synthesis of data derived from various subdisciplines that do not agree in every particular. Following convention, fossil occurrences are listed as highest and lowest rather than

the potentially confusing first and last. Sample depths may disagree slightly with measured depths. Data obtained from cores are given somewhat more weight than those from cuttings. Correlation with the other Norton Sound COST well is discussed at the conclusion of this report.

Paleoenvironmental determinations are based on the entire microfossil and macrofossil suites. Paleoclimatological interpretations are based on spore and pollen assemblages and, to a lesser extent, on diatoms, silicoflagellates and Foraminifera. Fluvial, lacustrine, and paludal environments are classified as continental or nonmarine. Transitional environments include brackish estuaries, marshes, and hypersaline and hyposaline lagoons. For sediments deposited in marine environments, the paleoenvironment is expressed in terms of bathymetry. Paleobathymetric determinations are primarily based on foraminiferal criteria, but dinoflagellates and other marine organisms such as bryozoans, echinoids, ophuroids, and cirripeds are also utilized. The marine environment is divided into inner neritic (0-60 feet), middle neritic (60-300 feet), outer neritic (300-600 feet), and upper bathyal (600-1500 feet).

Pleistocene

The interval from 180 to 1320 feet is Pleistocene in age on the basis of a foraminiferal fauna containing Elphidium bartletti, Elphidium clavatum, Elphidium incertum, Protoelphidium orbiculare, Elphidiella gorbunovi, Elphidiella oregonense, Elphidiella sibirica, Buccella frigida, Quinqueloculina seminulum, and Dentalina baggi.

A moderately diverse, though sparse, ostracode fauna containing specimens of Paracyprideis pseudopunctillata, Heterocyprideis sorbyana, Normanicythere leioderma, Rabilimis septentrionalis, "Acanthocythereis" dunelmensis, Cytheretta "edwardsi", and Elofsonella concinna substantiates this age (E. Brouwers, personal communication).

Although the siliceous microfossil assemblages in this interval contain a high percentage of reworked material, the presence of the diatoms Melosira sulcata, Coscinodiscus marginatus, Actinocyclus curvatulus, and Biddulphia aurita in association with the silicoflagellates Distephanus octangulatus and Distephanus octanarius also indicate a Pleistocene age.

Environment

The foraminiferal fauna and diatom flora indicate an inner neritic (0-60 feet) cold-water environment for the Pleistocene interval. Abundant molluscan fragments, barnacle plates, echinoid plates and spines, and fragments

of erect bryozoan colonies (adeoniform and vinculariiform) generally support this interpretation, although the bryozoans suggest possible middle neritic water depths (60-300 feet). The ostracode fauna indicates that these environments were characterized by periods of reduced or fluctuating salinities. The admixture of stenohaline and euryhaline forms can be explained by the complex interplay of glacio-eustatically controlled fluvial and marine processes.

Pliocene

The interval from 1320 to 2639 feet is Pliocene in age. Although the Pliocene siliceous microfossil assemblage contains a substantial number of older, reworked forms as well as Pleistocene species caved from uphole, the interval can be provisionally subdivided into late, middle, and early on the basis of diatom and silicoflagellate distributions. The late Pliocene, 1320 to 1608 feet, is identified by the highest occurrence of the diatoms Coscinodiscus marginatus fossilis, Stephanopyxis inermis, Actinocyclus ehrenbergii, Thalassiosira usatchevii, and Nitzschia fossilis. The middle Pliocene, 1608 to 2327 feet, is defined by the first occurrence of Thalassionema robusta, Thalassionema convexa aspinosa, Cosmiodiscus intersectus, Denticulopsis kamtschatica, and Distephanus boliviensis boliviensis. The early Pliocene, 2327 to 2639 feet, is defined by the lowest occurrences of Actinocyclus ochotensis and Ammodochium rectangulare. Siliceous microfossil zonations for all parts of the well are based on Koizumi (1973), Schrader (1973), and Baron (1980).

The foraminiferal fauna is essentially the same as that of the overlying Pleistocene with the exception of the highest occurrence of Pseudopolymorphina cf. P. suboblonga at 1500-30 feet.

The ostracode fauna is also quite similar to that of the overlying Pleistocene, with the addition of Rabilimis paramirabilis, Cytheretta teshekpukensis, Robertsonites tuberculata, and Eucytheridea punctillata. Most of these species have heretofore been considered Pleistocene with the exception of Rabilimis paramirabilis (1380 to 1410 feet), which has been reported only from Beringian-age sediments (late Pliocene-early Pleistocene).

The sparse terrestrial palynoflora contains Alnipollinites sp. and rare specimens of Betulaceae, Polypodiaceae, Polmoniaceae, and Chenopodiaceae. The marine palynoflora is characterized by common specimens of Tasmanaceae and the dinoflagellates Lejeunia spp., Paralecanicella indentata, and Operculdinium sp. 2. The latter species first occurs in a sidewall core taken at 1494 feet and marks the approximate position of the Pliocene-Pleistocene boundary in Alaska according to the consultants.

Environment

The Pliocene microfossil and macrofossil assemblages are indicative of cold water, inner neritic deposition.

Miocene

The interval from 2639 to 4493 feet is interpreted here to represent the Miocene section of the well. This interval can be further subdivided into late and early Miocene sections on the basis of siliceous microfossils. The absence of middle Miocene siliceous microfossil taxa in conjunction with the relatively good late and early Miocene assemblages suggests that this time may be represented by a hiatus, although the foraminiferal data appears to contradict this interpretation. Several distinctive foraminiferal species previously reported from the Miocene of Sakhalin Island, U.S.S.R. are present in the well at 3630-60 feet. The strata from which these forms were reported initially were considered to be late Miocene in age (Voloshinova, and others 1970). More recently these strata were assigned to the middle Miocene (Serova, 1976; Menner, and others 1977; Gladenkov, 1977). The ages of these units are still unsettled, and it is quite possible that they may prove to be older than middle Miocene (L. Marincovich, personal communication).

The late Miocene interval, defined by siliceous microfossil assemblages recovered from sidewall cores from 2639 to 3464 feet, is recognized by the lowest continuous occurrence of Melosira sulcata; the lowest occurrences of Thalassiosira zabelinae, Thalassiosira convexa aspinosa, Pseudopyxilla americana, and Ebriopsis antiqua antiqua; the highest occurrences of Coscinodiscus temperei, Coscinodiscus vetustissimus, and Goniothecum tenue; and the ubiquitous presence of Actinocyclus ingens.

The interval from 3464 to 4493 feet is early Miocene in age on the basis of the lowest occurrence of Thalassionema nitzschioides, Stephanopyxis turris, Stephanopyxis schenckii, and Actinocyclus ingens.

The Miocene foraminiferal fauna first encountered at 3630-60 feet is characterized by Porosorotalia clarki, Elphidiella katangliensis, Elphidiella cf. E. tenera, Elphidiella cf. E. crassorugosa, Elphidiella cf. E. nagaii, Criboelphidium cf. C. vulgare, Criboelphidium cf. C. paromaense, Criboelphidium crassum, Ellipsoglandulina cf. E. subobesa, Pseudoglandulina sp., Glandulina cf. G. japonica, Buccella frigida, Buccella aff. B. mansfieldi, Buliminella cf. B. curta, and Pyrgo williamsoni.

The terrestrial palynoflora over this interval is quite similar to that of the Pliocene section. New elements include Ulmipollenites sp., Tiliaepollenites sp., Juglanspollinites sp., Pterocaryapollenites sp., and Bosiduvalinia sp.

The dinoflagellate assemblage includes Spiniferites cingulatus, Spiniferites cf. S. crassipellis, Spiniferites cf. S. incertus, Lejeunia spp., and Tuberculodinium vancampoae. Both the spore-pollen and dinoflagellate assemblages suggest a Miocene age for this interval.

Environment

Evidence from all of the microfossil groups suggests deposition in an inner to middle neritic environment (0-300 feet). Paleotemperatures were

colder during the late Miocene than in the subtropical to warm-temperate early Miocene.

Oligocene

The interval from 4493 to 9690 feet is considered to be Oligocene in age. The top of the Oligocene section is marked by the highest occurrence of the dinoflagellate Achomosphaera aff. A. alcicornu. According to the palynological consultant, this species has been previously recorded in Oligocene strata in western Alaska. Achomosphaera alcicornu ranges from middle Eocene to middle Miocene in Europe and from late Paleocene through the Eocene in eastern Canada. Other dinoflagellates associated with this species, Tenua cf. T. decorata, Systematophora placacantha (early Eocene through late Miocene), and Distatodinium ellipticum (middle Eocene through early Oligocene) lend support to an Oligocene age for the interval.

The calcareous nannoplankton recovered from the well are rare, poorly preserved, and relatively nondiagnostic. None occurs above 5100 feet. The interval from 5101 to 10,590 feet is characterized by sporadic appearances of Braarudosphaera bigelowi associated with rare coccoliths and placoliths of a small, somewhat problematical form with affinities to species in the Coccolithus miopelagicus plexus. While not definitive, these forms suggest a middle Miocene to late Oligocene age. Somewhat more definitive is the occurrence of Thoracosphaera heimi at 9150-9240 feet, which indicates an age no older than middle Oligocene, possibly within the Sphenolithus ciperensis zone.

The foraminiferal assemblage supports an Oligocene age although many of the species present range into the Miocene. The upper part of the interval (4493 to 5400 feet) is characterized by a fauna that contains dominantly shallow water forms such as Elphidiella katangliensis, Elphidiella nagaoui, Elphidium spp., Criboelphidium spp. Buccella frigida, Miliammina fusca, Rotalia cf. R. katangliensis, Rotalia japonica, and Rotalia japonica varianta. A deeper water assemblage, present from 5400 to 9690 feet, contains most of the above listed species as well as Psammosphaera carnata, Ammodiscus tenuis, Ammodiscus sakhalinicus, Libusella laevigata, Martinottiella cf. M. communis, Martinottiella bradyana, Hippocrepinella variabilis, Haplophragmoides spp., Haplophragmoides tortuosus, Gaudryina quadrangularis, Plectina sp., Dorothia sp., Rhabdammina aspera, Reophax spp., Bathysiphon edurus, Bathysiphon sp., Tritaxilina aff. T. colei, Pullenia sp., Cyclammina cf. C. tumiensis, Cyclammina cf. C. pacifica, Cyclammina sp., Eponides cf. E. dorfi, Eponides cf. E. gaviotaensis, Pseudoglandulina nallpeensis, Sigmomorphina suspecta, Sigmoidella pacifica, Fissurina marginata, Trichyohyalus bartletti, Silicosigmoilina sp., Buccella mansfieldi, Porosorotalia clarki, Elphidiella cf. E. californica, Elphidiella cf. E. problematica, Globobulimina sp., Robulus cf. R. midwayensis, Lagena laevis, Quinqueloculina sawanensis, Quinqueloculina sachalinica, Ellipsoglandulina subobesa, Buliminella subfusiformis, and several species of Caucasina. The latter are quite significant. Caucasina schwageri (highest occurrence at 6570-6600 feet), Caucasina eocenica kamchatica (highest occurrence at 6960-90 feet), and Caucasina bullata (highest occurrence at 8640-70 feet) characterize the Caucasina eocenica kamchatica Zone in the Ilpinsky and Kamchatka peninsulas in the U.S.S.R. This zone is thought by Serova (1976) to define the Eocene-

Oligocene boundary. Microfossil evidence obtained from the Norton Sound COST No. 1 Well, however, indicates that the aforementioned species of Caucasina range into Oligocene time.

Environment

The Oligocene section of the well is dominantly marine in aspect. The upper part of the interval (4493 to 4740 feet) was deposited in essentially the same environment as the overlying Miocene, inner to middle neritic. A transitional to continental coal-bearing section is present between 4740 and 4980 feet. The interval from 4980 to 5400 feet is inner to middle neritic and represents a shoaling event transitional between the upper nonmarine section and the deep water section below 5400 feet. Outer neritic to upper bathyal depths (300 to 1500 feet) prevailed over the interval from 5400 to 9690 feet. The most diverse deep water microfossil assemblages are present from 8130 to 9690 feet. The terrestrially derived spore-pollen assemblage indicates that subtropical to warm temperate climatic conditions prevailed during most of Oligocene time.

Oligocene or Older

Microfossil recovery and preservation from 9690 to 12,235 feet was quite poor. Most of the rare foraminiferal occurrences appear to represent caved material. The in situ palynomorphs are terrestrially derived. Abundant plant material is disseminated through the massive sandstone units and as subparallel partings. Mica flakes and plant material are common in the fine grained laminae. Neither the age nor the environment can be unequivocally determined. It is

possible that this section is in part equivalent to the late and middle Eocene sections of the Norton Sound COST No. 2 Well. Sedimentary features such as graded bedding and flame structures seen in cores eight and nine (11,960-988 and 12,071-091 feet) suggest deposition by turbidity currents. Bioturbation is not extensive or diagnostic. The infrequent burrows present in the massive sandstone units cannot be related to a particular ichnofacies. However, rare traces observed on bedding planes in the laminated sequences of core eight resemble the ichnogenus Planolites and the "scribbling grazing traces" of a trace fossil assemblage typical of distal turbidites. These strata could have been deposited in either a relatively deep water marine environment or a rapidly subsiding large lacustrine environment.

Possible Eocene or Older

No age diagnostic microfossils were recovered from the interval between 12,235 and 12,545 feet. Rare, poorly preserved spores and pollen are present. The 310-foot-thick section, bounded above and below by unconformities, appears to be roughly correlative with much thicker Eocene or older coal-bearing sequences in the nearby Norton Sound COST No. 2 Well.

Environment

The presence of terrestrial spores and pollen in association with abundant coal indicates that the sediments are continental (fluvial and paludal) in nature. The paleoclimate was probably tropical to subtropical.

Metamorphic Basement

The well penetrated a 2135-foot-thick section of cataclastically deformed pelitic and psammitic metasedimentary rocks of undetermined age. Several lines of evidence suggest that these rocks may be related to rocks from the York Mountains in the western part of the Seward Peninsula considered to be Precambrian to Paleozoic (Sainsbury, and others, 1970; A. Till, J. Dumoulin, personal communication).

Correlation

The strata identified in the Norton Sound COST No. 1 and No. 2 Wells can be biostratigraphically correlated despite the fact that they are located approximately 49 nautical miles apart and were deposited in geographically distinct and tectonically independent subbasins (fig. 17). Depositional environments also differed. Those of the St. Lawrence subbasin, the site of the No. 1 well (fig. 18), are more marine than those of the Stuart subbasin, the site of the No. 2 well (fig. 19). However, similarities between the two wells are more pronounced than are the differences, particularly in the marine sequences seen above 6800 feet in both. Correlations are somewhat more difficult below 6800 feet in that the nonmarine and transitional strata in the No. 2 well must be compared with the predominantly shelf and continental slope deposits of the No. 1 well. With the exception of the Eocene or older section, which is far thicker in the No. 2 well, time-equivalent units are also roughly equivalent in thickness. Sedimentation rates were not calculated because of the tentative nature of some of the biostratigraphic boundaries.

Figure 17. Biostratigraphic Correlation of Norton Sound COST Wells

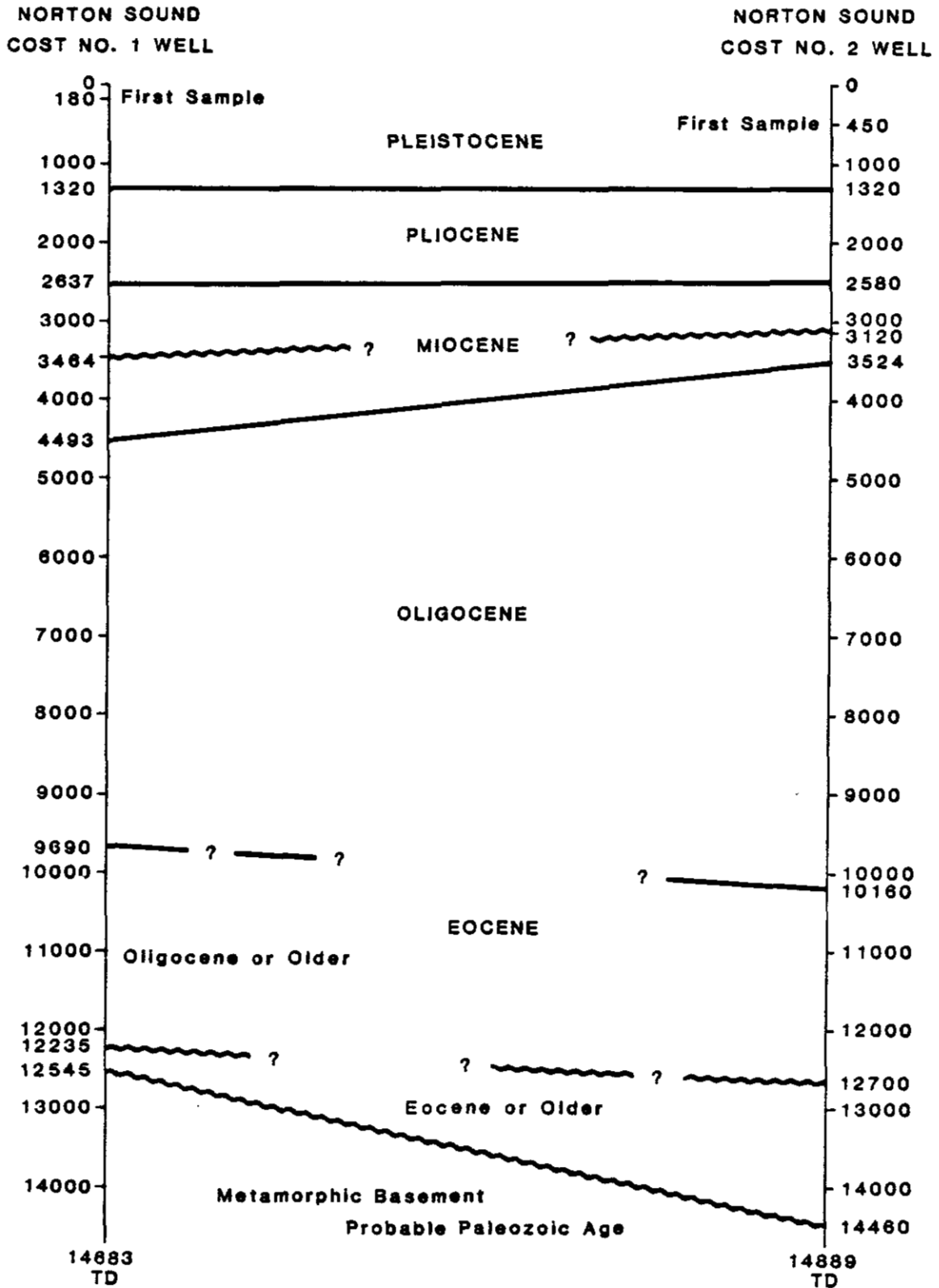

Figure 18. STRATIGRAPHIC SUMMARY of NORTON SOUND COST No.1 WELL

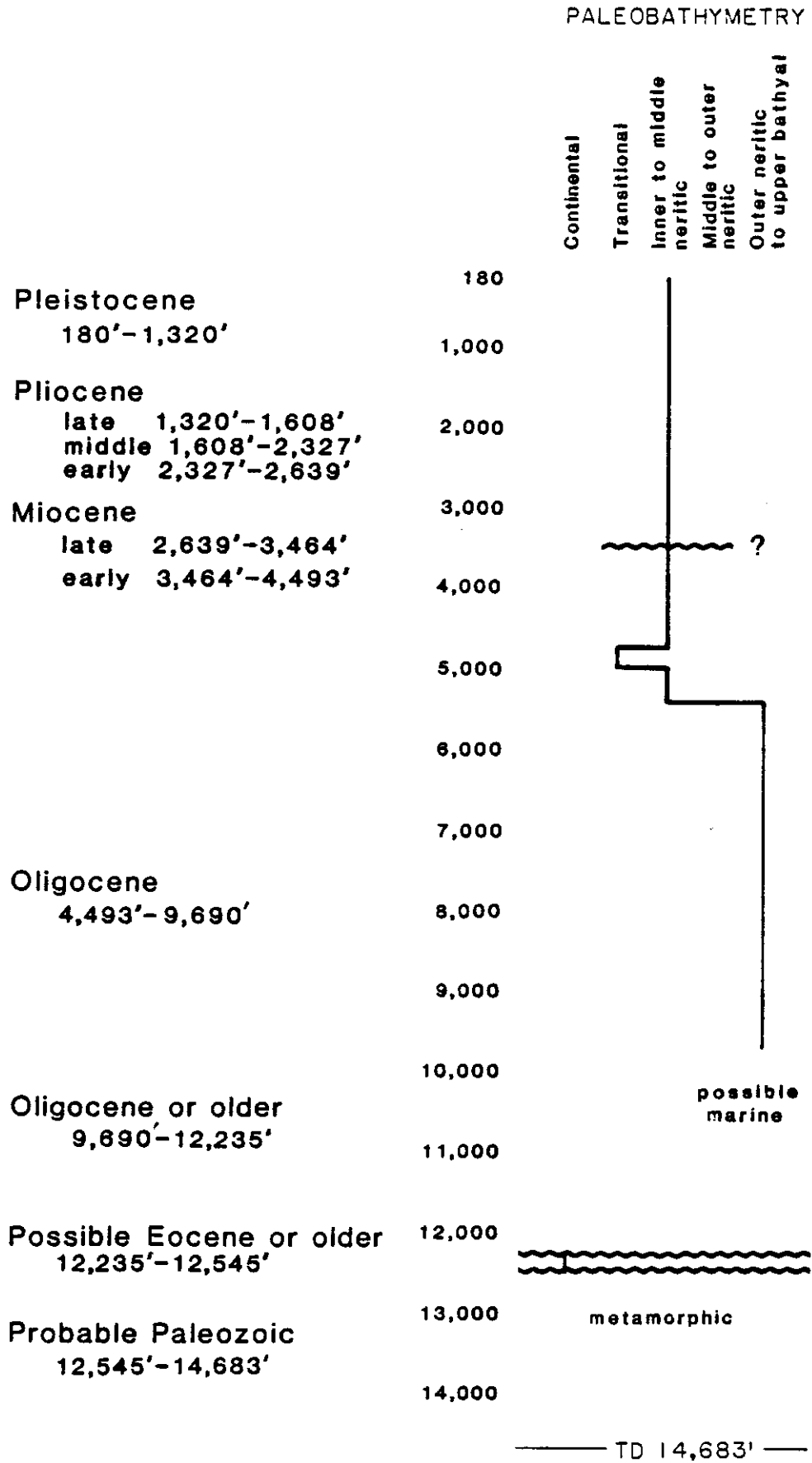
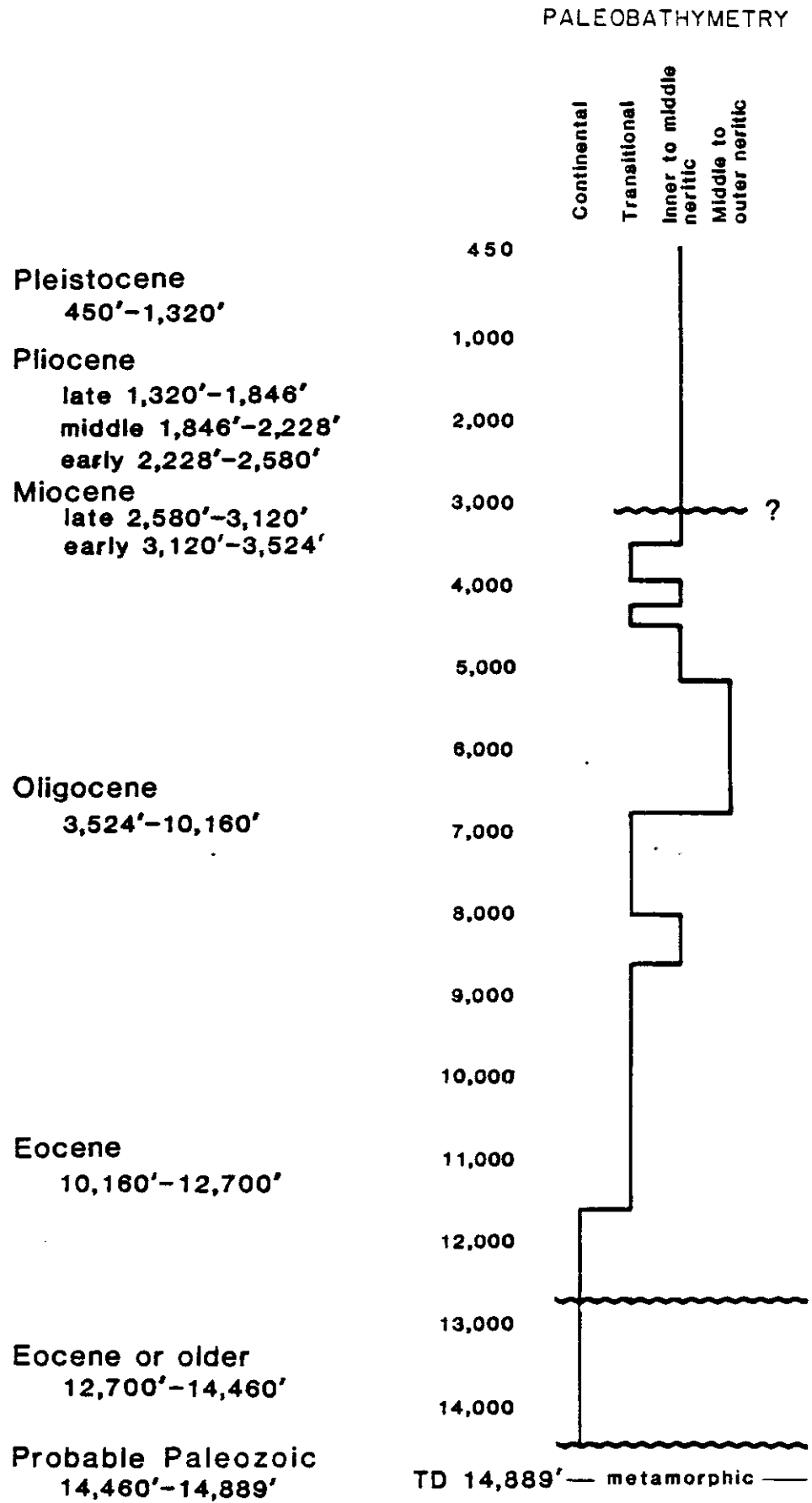

Figure 19. STRATIGRAPHIC SUMMARY of NORTON SOUND COST No. 2 WELL



Pleistocene

The first sample in each well is Pleistocene in age, although it is almost certain that a thin Holocene section was penetrated. Sample quality is poor. The base of the Pleistocene is placed at 1320 feet in both wells. Microfossil assemblages, lithology, and depositional environments are essentially identical. Shallow seismic evidence suggests that there may be a slight unconformity between the Pliocene and the Pleistocene.

Pliocene

The top of the Pliocene is at 1320 feet in each well, the base at 2639 feet in the No. 1 well and 2580 feet in the No. 2 well. The Pliocene was subdivided into early, middle, and late in both wells on the basis of siliceous microfossil assemblages, but the chaotic mixture of reworked and caved forms renders such subdivision tentative and provisional at best. In general, the microfossil assemblages in both wells reflect similar paleoenvironments.

Miocene

The top of the Miocene is at 2639 feet in the No. 1 well, and at 2580 feet in the No. 2 well. There appears to be a middle Miocene hiatus, perhaps a paraconformity, present in both wells. This "surface" is defined in both wells by the top of the early Miocene, 3464 feet in the No. 1 well and 3120 feet in the No. 2 well. The base of the early Miocene is at 4493 feet in the No. 1

well and at 3524 feet in the No. 2 well. Microfossil assemblages and lithologies are quite similar in both wells, although there is some evidence that deposition was at shallower depths in the No. 2 well.

Oligocene

Strata assigned to the Oligocene epoch account for roughly half of the sedimentary section penetrated by the wells, a 5197-foot-thick sequence in the No. 1 well, 6644 feet in the No. 2 well. In the No. 1 well the Oligocene section (4493-9690 feet) is represented almost entirely by marine deposition, much of it outer shelf and upper slope. By way of contrast, in the Oligocene section of the No. 2 well (3524-10,160 feet) well over half of the sediments are coalbearing and were deposited under continental to transitional conditions.

There is a small, but pronounced, continental to transitional environment present near the top of the Oligocene section in the No. 1 well (4740-4980 feet) that is correlative with the coal beds seen in the No. 2 well at 3424 to 3930 feet and at 4250 to 4440 feet. The marine transgressive section at 5360 to 6770 feet in the No. 2 well is certainly in part correlative with the upper bathyal environments seen below 8130 feet in the No. 1 well.

Eocene

Definite late to middle Eocene strata are present from 10,160 to 12,700 feet in the No. 2 well. Although no Eocene fossils were found in the No. 1 well, it is possible that the problematic Oligocene or older section (9,690 to 12,235 feet) is in part correlative with the Eocene section in the No. 2 well.

Eocene or Older

In both wells a coal-bearing section unconformably overlies the regional early Tertiary to late Mesozoic erosional surface. This continental section, 310 feet thick in the No. 1 well and 1760 feet thick in the No. 2 well, is truncated by an unconformity at 12,235 feet in the No. 1 well and at 12,700 feet in the No. 2 well. Because both deposition and erosion took place in two subbasins separated by a positive tectonic element, this unconformity is not characterized by a continuous seismic reflector. Nevertheless, it is reasonable to assume that the unconformities are approximately coeval. Likewise, on the basis of lithology, depositional environment, stratigraphic position, and the similar preservational state of the palynomorphs, it seems probable that the Eocene or older sections in the two wells are in part correlative.

Basement Complex (Possible Paleozoic)

Both wells penetrated metasedimentary sections below the regional unconformity that marks acoustic basement. The 2135-foot-thick sequence

of cataclastic rocks in the No. 1 well appears quite similar to slate of late Precambrian to Paleozoic age described from the York Mountains of the Seward Peninsula; the 429 feet of quartzite, phyllite, and marble identified in the No. 2 well appears to be quite similar to metamorphic rocks of probable Paleozoic age described from the central and eastern parts of the Seward Peninsula. It is not presently possible to more closely relate the metamorphic sections of the two wells on the basis of either age or genesis.

LITHOLOGY
AND
GEOPHYSICAL LOG INTERPRETATION

by J. G. Bolm

Examination of cuttings, conventional and sidewall cores, and geophysical logs from the Norton Sound No. 1 well provided information on the lithology, depositional environment, reservoir characteristics, and hydrocarbon source-rock potential of the strata penetrated. Lithologies and reservoir characteristics discussed in this section are based on consultants' reports, especially the petrologic report by AGAT Consultants, Inc., and on examination of samples and geophysical logs. The gamma-ray, spontaneous potential (SP), deep resistivity, density, and sonic logs are presented with other geological and geochemical data in Plate 1.

Geophysical logging of the well began at 1210 feet, and recovery of cuttings was poor above 1230 feet owing to problems with lost circulation. The few cuttings recovered from this uppermost part of the well are predominantly siltstone with some very fine sandstone and fragments of muscovite, chlorite, and biotite, schist, and greenstone. Molluscan shell debris is common.

1210-1900 feet

The interval from 1210 to 1900 feet is characterized by diatomaceous sandy mudstone. Where bioturbation has not been too severe, lamination, defined by

varying abundances of sand and mud and by orientation of elongate sand clasts, is seen. Pyrite cement is present in a few small areas of sandy laminae, but more commonly such laminae are the sites of considerable intergranular porosity. Sand clasts are predominantly very fine to fine and subangular to subrounded and consist of quartz, feldspar, and green hornblende with minor brown biotite, chlorite, and muscovite. Quartz clasts are mostly monocrystalline with undulatory extinction, but there are some polycrystalline quartz clasts. The feldspar is principally plagioclase with minor amounts of potassium-feldspar. The matrix contains scattered pyrite framboids and minor glauconite.

The gamma-ray and SP logs suggest this interval is dominated by 25- to 75-foot-thick beds of relatively coarse-grained sand with thin, finer grained interbeds. Resistivities are low with a difference of about 0.5 ohm-m common between the deepest and shallowest measured resistivities. The density log indicates densities generally between 1.75 and 2 g/cm³ for these rocks. The sonic log is invalid from 1680 to 1817 feet owing to noise; elsewhere interval transit times average about 165 μ s/foot.

The presence of abundant marine fossil material and glauconite indicate that the rocks of this interval were deposited in a marine shelf environment.

1900-3730 feet

The interval from 1900 to 3730 feet is characterized by diatomites, muddy diatomites, and diatomaceous mudstones that are similar to the rocks above except for the generally greater abundance of diatoms.

The gamma-ray and SP curves lack distinctive character through this interval. Resistivities remain low as in the previous interval. Below 2500 feet all three resistivity tools generally read the same value. The density log indicates densities of about 1.75 g/cm^3 for these rocks, and average interval transit times taken from the sonic log decrease from about 160 $\mu\text{s}/\text{foot}$ to about 150 $\mu\text{s}/\text{foot}$ downward through the interval.

The rocks of this interval are quite similar to the rocks in the interval above and were deposited in the same type of marine shelf environment.

3730-4700 feet

The interval from 3730 to 4700 feet is characterized by mudstone similar to that in the interval above. There is a sudden but slight increase in gamma-ray and SP values at the top of this interval. Resistivity curves continue smoothly down into this interval, and retain the character that they assumed at 2500 feet almost to the bottom of the interval, but values are somewhat more erratic in the bottom 100 feet. The density log shows a rapid increase in density at the top of this interval such that density exceeds 2 g/cm^3 at 3750 feet. From 3750 feet, density increases gradually to the bottom of the interval where it averages about 2.2 g/cm^3 . The sonic log shows a similar sharp decrease in interval transit time from 150 to 135 $\mu\text{s}/\text{foot}$ at the top of the interval and a gradual decrease to an average interval transit time of about 130 $\mu\text{s}/\text{foot}$ at the base of the interval.

The rocks of this interval were deposited in a marine shelf environment as indicated by their content of marine fossils.

4700-5005 feet

The interval from 4700 to 5005 feet is characterized by shale, sandstone, and minor coal. The shale contains scattered silt and sand grains. Locally thin, very fine sandstone laminae parallel fissility in the shale, as do the oriented plates of muscovite, which is abundant in the shale, and wisps of opaque material. The sandstone is poorly to moderately sorted and consists of very fine to medium sand grains with varying amounts of detrital mud matrix. Quartz is the principal sand component and is present primarily in subangular monocrystalline grains that show undulatory extinction. Plagioclase, much of it un-twinned, is the most common feldspar, but potassium-feldspar is also common. Most feldspar grains are unaltered. Detrital muscovite, detrital brown biotite, detrital chert, volcanic rock fragments, and framboidal pyrite are present in minor amounts locally. Detrital mud matrix is present in scattered areas or in thin lenses and partings, and the orientation of elongate clasts defines lamination in places.

Authigenic smectitic clay and pyrite are present as cement in sandstones from this interval. Where intergranular space is not filled by cement or mud, up to 25 percent intergranular porosity may be visible. Porosity is irregularly

distributed even on the scale of a thin section and is most commonly present in the cleanest sandstones, although some porosity is present in muddy sandstones. Etched clast boundaries, honeycombed clasts (especially feldspar), and the presence of a few oversized pores suggest that porosity is at least partly secondary. A sidewall core of sandstone from this interval had 28.7 percent porosity and 9.41 mD permeability.

The SP curve displays several scattered, thin, sharp kicks indicative of minor sandstone beds in this interval. Four 10- to 50-foot sandstone beds with a total thickness of 110 feet are defined by the gamma-ray and SP logs. Deep and shallow resistivity values remain generally the same through this interval, but resistivity values vary more here than in the interval above. The density and sonic logs are quite variable through this section. The density log indicates average porosities of 24 to 27 percent for the thicker sandstone beds and average sonic porosities corrected for compaction range from 26 to 29 percent for the same beds.

Coal is present in cuttings from this interval. Beds are evidently thin, however, as they cannot be unambiguously located on geophysical logs.

The association of coal, shale, and poorly sorted sandstone present in this interval suggests deposition in a fluvial or deltaic environment. Recovery of marine fossils (see Paleontology and Biostratigraphy section of this report) indicates that some of the rocks in the interval were deposited in a

marine environment, and it is likely that deposition was near a coastline where marine and nonmarine environments alternated through time.

5005-9685 feet

The interval from 5005 to 9685 feet is characterized by mudstone and shale with some interbedded sandstone. Conventional cores 2, 3, and 4 are from this interval and are described in figures 20, 21, and 22.

The shales and mudstones in this interval are generally less silty or sandy than those from higher in the well. Mica, especially muscovite, is common, and the orientation of mica plates and wisps of opaque material parallel fissility in the shales and define laminations in many of the mudstones. Burrows are common in shale and mudstone in conventional cores from this interval, and bivalves are common in core 2 near the top of the interval. AGAT Consultants, Inc., reports glauconite in one sample from 9440 feet.

The sandstone is similar to that of the interval above but commonly contains minor glauconite. Sparry calcite, micritic siderite, and kaolinitic clay are present in addition to authigenic smectitic clay and pyrite as cements in this interval. As in shallower sandstones, up to 25 percent intergranular porosity is visible in the cleaner parts of this sandstone, and etched clast boundaries, honeycombed clasts, and oversized pores suggest that porosity here is also at least partly secondary. Porosity ranges from 16.7 to 23.6 percent in nine

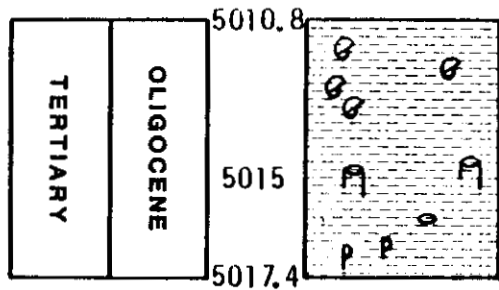

Shale, olive-black (5Y 2/1) to olive-gray (5Y 4/1), one 1.5-cm volcanic pebble, bivalves common, fissile, several thin carbonaceous zones, some burrows minor pyrite, friable.

		1.50	0.37	5015.5
--	--	------	------	--------

Vitrinite Reflectance (Percent)
Total Organic Carbon (Percent)
Permeability (Millidarcies)
Porosity (Percent)

Explanation
A-burrow
⊖-bivalve
⊙-gastropod
λ-flame structure
p-pyrite
∟-cross-bedding

Figure 20. Description of conventional core 2, Norton Sound COST No. 1 well [Geochemical Analyses by Data Core Laboratories, Inc.]

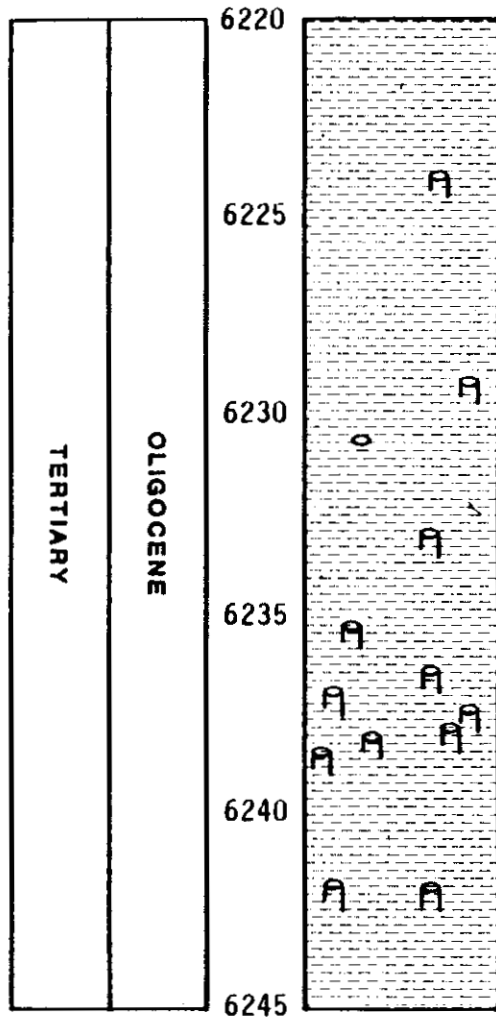

Shale, olive-gray (5Y 4/1), slightly silty with one 2.5-cm volcanic pebble, weakly to strongly fissile, scattered carbonaceous stringers and lenses, locally burrowed, carbonate-filled tension gashes at 6232.6 and 6233.5 feet.

Explanation
A-burrow
O-bivalve
P-gastropod
S-flame structure
p-pyrite
Y-cross-bedding

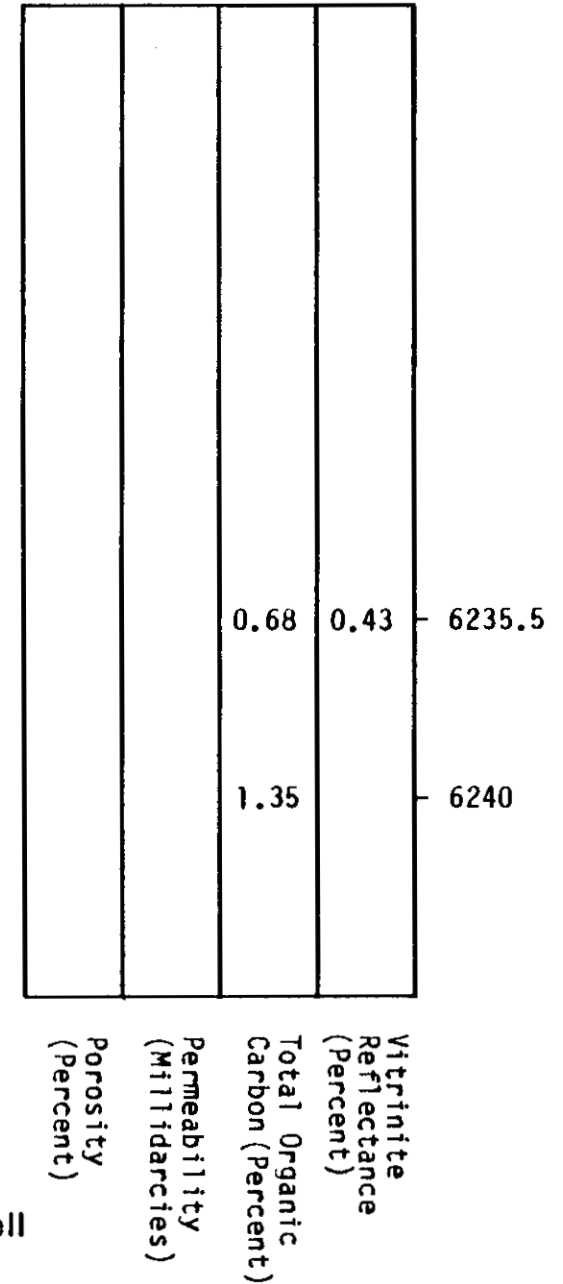
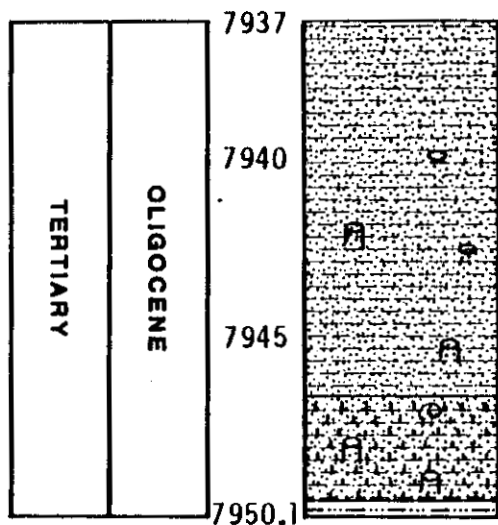

Figure 21. Description of conventional core 3, Norton Sound COST No. 1 well [Geochemical Analyses by Data Core Laboratories, Inc.]



Mudstone and sandstone, olive-black (5Y 2/1); mudstone is sandy, sandstone is muddy, and lithologies grade into each other; one 3-cm marble pebble, massive to weakly laminated, local burrows with some burrows carbonate-filled.

Sandstone, medium-dark-gray (N-4), very fine grained, calcareous, one gastropod, weakly laminated or wavy laminated, extensively burrowed locally.

Siltstone, olive-black (5Y 2/1), sandy, calcareous, cross-laminated, burrowed.

Explanation
□-burrow
○-bivalve
⊖-gastropod
△-flame structure
⊖-pyrite
⊗-cross-bedding

		1.04	0.49	7937.5
22.3	0.30			
21.7	0.36			
21.1	0.30			

Porosity
(Percent)

Permeability
(Millidarcies)

Total Organic Carbon
(Percent)

Vitritine Reflectance
(Percent)

Figure 22. Description of conventional core 4, Norton Sound COST No. 1 well [Geochemical Analyses by Data Core Laboratories, Inc.]

sidewall and three conventional core samples of sandstone from this interval. Permeability ranges from 0.3 to 21 mD in the same samples, but the higher permeability values in this range may be caused by disturbance of the lithic fabric attendant on the taking of sidewall cores. The highest permeability in a conventional core sample was 0.36 mD. Burrows and a gastropod are present in the sandstone of conventional core 4.

The SP curve is generally flat through this interval with scattered, thin, sharp kicks indicative of thin sandstone beds. The gamma-ray curve varies erratically within a limited range of API units. A single 60-foot-thick sandstone bed from 5315 to 5375 feet is indicated by the SP and gamma-ray logs. Deep and shallow resistivity measurements remain similar through this interval, and resistivity values retain the variability they displayed in the interval above. Average resistivity is between 1 and 2 ohm-m. Densities range from 2.0 to 2.5 g/cm³ through this interval, and the density log indicates an average porosity of 25 percent for the 60-foot sandstone bed. The sonic log indicates a general decrease in interval transit time from 155 to 95 μ s/foot downward through the interval, and the average sonic porosity corrected for compaction is 26 percent for the 60-foot sandstone bed.

The presence of glauconite and fossil fragments in the rocks in this interval indicate deposition in a marine environment.

9685-10,300 feet

The interval from 9685 to 10,300 feet is characterized by interbedded sandstone and mudstone. Conventional core 5 is from this interval and is described in figure 23.

The sandstone in this interval is moderately to well sorted and fine to medium grained. The sand grains are generally subrounded to rounded. Principal framework components are quartz, muscovite, plagioclase, and metamorphic rock fragments. Quartz comprises 50 to 65 percent of the framework clasts and includes both monocrystalline and polycrystalline grains. Muscovite comprises 15 to 30 percent of the framework clasts and is present generally in large, unaltered grains. Plagioclase comprises 10 to 20 percent of the framework clasts and is commonly untwinned, unaltered, and of albitic composition. Metamorphic rock fragments comprise about 10 percent of the framework clasts and consist predominantly of phyllite and fine-grained mica schist and quartz-mica schist. Minor amounts of volcanic rock fragments, pyrite, chlorite, and brown biotite are commonly present in the sandstone, and the orientation of mica flakes and other elongate clasts commonly define lamination.

Ductile grain deformation and postdepositional crinkled mica are common in the sandstones of this interval and have reduced intergranular porosity. Authigenic quartz cementation has further reduced porosity. The combination of syntaxial quartz overgrowths and ductile grain deformation has commonly produced a tight mosaic structure in these quartz-rich rocks, and other cements (described in shallower sandstones) are generally restricted to isolated,

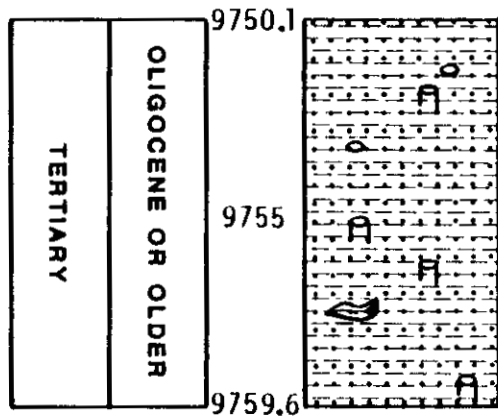

Mudstone, black (N-1) and pale-brown (5 YR 5/2), sandy with rare volcanic, and pyrite pebbles and one cobble-size rip-up clast, laminated, scattered pyritized burrows, abundant disseminated pyrite.

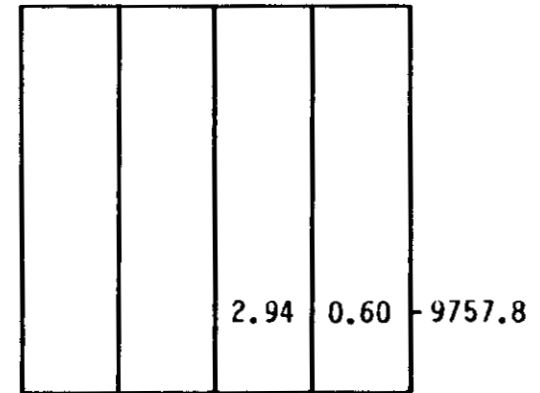

Vitrinite Reflectance (Percent)
 Total Organic Carbon (Percent)
 Permeability (Millidarcies)
 Porosity (Percent)

Explanation
A - burrow
Q - bivalve
G - gastropod
L - flame structure
P - pyrite
Z - cross-bedding

Figure 23. Description of conventional core 5, Norton Sound COST No. 1 well [Geochemical Analyses by Data Core Laboratories, Inc.]

scattered areas. Up to 15 percent visible intergranular porosity exists in some such areas without quartz cement. This porosity appears to be largely secondary and to have been formed by the dissolution of sparry calcite cement. A single sidewall core from a sandstone in this interval has 23.9 percent porosity and 18 mD permeability. The high permeability of this sample is probably due to fabric disruption induced by sample collection. Very low permeabilities should be expected for this sandstone in which small porous areas are isolated in generally very nonporous rock.

The mudstone is massive or laminated with the lamination defined by the orientation of muscovite flakes or flattened concentrations of organic material. The mudstone is locally interlaminated with sandstone and contains scattered patches of micritic siderite. Rare burrows are present in core 5 (9750-9759.6 feet) from near the top of the interval.

The gamma-ray log maintains the same character through this interval as it had in the interval above but increases abruptly 20 API units in average value at the upper boundary of the interval. The SP log continues through this interval just as it was in the interval above. An average deep resistivity of about 4 ohm-m characterizes this interval. Shallow resistivity measurements are generally 1 ohm-m higher than deep resistivity measurements, and deep and shallow resistivity curves parallel each other through the interval with a few scattered, large magnitude kicks. Density is quite variable through this interval with extreme values of 2 and 2.7 g/cm³, but average density values range from 2.25 to 2.55 g/cm³. The density log indicates a porosity of 6

percent in the vicinity of a sidewall core that has a measured porosity of 23.9 percent. The sonic log is much less variable than the density log through this interval. Interval transit time ranges from 76 to 102 μ s/foot with average values generally between 90 and 95 μ s/foot. The sonic log indicates a porosity of 22 percent in the vicinity of the above mentioned sidewall core.

Although neither marine fossils nor environmentally specific sedimentary structures have been observed in the rocks of this interval, it is likely that the thick sequence of burrowed mudstone and sandstone was deposited in a marine environment.

10,300-10,640 feet

The interval from 10,300 to 10,640 feet is characterized by interbedded sandstone, mudstone, and igneous rock. Conventional core 6 is from this interval and is described in figure 24.

The sedimentary rocks of this interval are similar to those of the interval above. The predominant igneous lithology is basalt, which is fine- to medium-grained with a maximum grain size of about 2 mm. Most of this basalt displays an intersertal texture in which the interstices between the plagioclase laths are filled with calcite, clay, and magnetite. Some ragged grains of clinopyroxene are present in the interstitial fill. Calcite, chalcedony, and clay amygdules

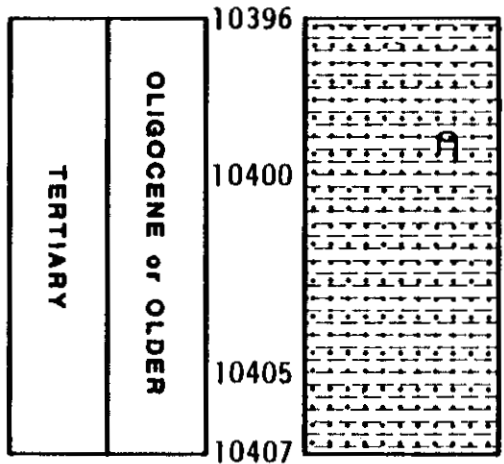

Mudstone, black (N-1) with some medium-olive-gray (5Y 5/1) laminae, slightly sandy, few burrows, unmineralized shears with small normal offsets.

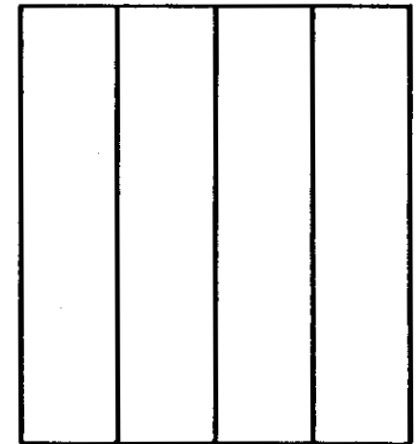

Vitrinite Reflectance
(Percent)
Total Organic Carbon
(Percent)
Permeability
(Millidarcies)
Porosity
(Percent)

Explanation
A - burrow
Q - bivalve
⊙ - gastropod
λ - flame structure
p - pyrite
Y - cross-bedding

Figure 24. Description of conventional core 6, Norton Sound COST No. 1 well [Geochemical analyses by Data Core Laboratories, Inc.]

are present in some samples. A sidewall-core sample from 10,332 feet is a trachyte texturally similar to the basalt described above but contains potassium feldspar instead of plagioclase. The interstices between the feldspar laths are filled with calcite, clay, and magnetite with some remnants of clinopyroxene and subhedral analcime crystals. A third igneous lithology is represented by a sidewall-core sample from 10,346 feet which consists of altered vitrophyre in which clinopyroxene remnants and chalcedony amygdules are present in a clay matrix.

Whole rock chemical analyses were run on two small samples of fine-grained basalt obtained from cuttings from 10,320 to 10,350 and from 10,590 to 10,620 feet. The analyses were made for Minerals Management Service by Chemical and Geological Laboratories of Alaska, Inc., using the inductively coupled argon plasma method of atomic emission spectroscopy. Normalized results of the analyses were used to calculate C.I.P.W. norms for the samples. Analytical results expressed in oxide weight percent, normalized oxide-weight-percent values, and norms are presented in Table 1 with oxide compositions of tholeiitic and alkali basalt. Total oxide weight percents as determined in the analyses deviate significantly from 100. Loss on ignition of volatiles was not recorded, and given the large amounts of calcite and clay observed in thin sections of the basalt, it is likely that considerable carbon dioxide and water were so lost. The basalt samples are abnormally low in alkalis, especially sodium oxide (Table 1). Based on Miyashiro's plot of iron-oxide to magnesium-oxide ratio against silica (1974), which is independent of alkali content, the samples are classified as tholeiitic.

Table 1.--BASALT CHEMISTRY DATA

[Analyses of samples 1 and 2 by Chemical and Geological Laboratories of Alaska, Inc.]

Mineral	Chemical Compositions (Oxide Weight Percents)										Normalized Mineral Composition (Weight Percent)			
	Sample 1		Sample 2		Continental Tholeiitic Basalt*		Oceanic Tholeiitic Basalt*		Alkali Basalt*					
	Actual	Normalized	Actual	Normalized	Average	Range	Average	Range	Average	Range	Sample 1	Sample 2	Sample 1	Sample 2
SiO ₂	45.80	52.36	50.50	53.92	50.7	44.35-54.6	49.3	42.8-52.56	47.1	41.04-51.4				
TiO ₂	2.00	2.29	2.60	2.78	2.0	0.9-3.99	1.8	0.35-3.69	2.7	0.92-4.52				
Al ₂ O ₃	13.60	15.55	15.10	16.12	14.4	12.48-16.32	15.2	7.3-22.3	15.3	10.11-26.26	Q	18.5	Q	20.3
Fe ₂ O ₃	3.50	4.00	4.10	4.38	3.2	0.95-7.56	2.4	0.69-7.90	4.3	0.53-15.85	Or	0.3	Or	0.2
FeO	3.34	3.82	5.18	5.53	9.8	4.18-13.60	8.0	2.87-13.58	8.3	0.48-13.63	Ab	1.9	Ab	7.0
MnO	0.29	0.33	0.15	0.16	0.2	0.10-0.3	0.17	0.09-0.44	0.17	0.06-0.36	An	41.3	An	40.2
MgO	2.71	3.10	4.95	5.28	6.2	3.52-11.16	8.3	4.59-26.0	7.0	2.66-17.87	Wo	9.5	Di	8.7
CaO	15.68	17.93	10.00	10.68	9.4	7.45-11.8	10.8	6.69-14.1	9.0	6.81-14.46	Di	17.6	Hy	11.3
Na ₂ O	0.19	0.22	0.78	0.83	2.6	1.8-3.47	2.6	0.90-4.45	3.4	1.35-4.8	Mt	5.8	Mt	6.4
K ₂ O	0.04	0.05	0.04	0.04	1.0	0.19-1.74	0.24	0.04-0.70	1.2	0.13-2.5	Il	4.3	Il	5.3
P ₂ O ₅	0.32	0.37	0.25	0.27		0.09-0.81	0.21	0.06-0.56	0.41	0.09-0.93	Ap	0.8	Ap	0.6
Total	87.47	100.02	93.65	99.99	99.5		99.02		98.88					

*from Hyndman (1972, p. 171)

The SP curve lacks interpretable character in this interval. The gamma-ray curve, however, shows three large, blocky excursions to lower values from a base similar in character to the interval above. Sidewall-core samples from within these three zones are of igneous lithologies, and it is likely that each zone of low gamma-ray flux represents an igneous unit.

The resistivity log is much more variable in this interval than in the interval above. Especially large variations in resistivity are present in a washed out section that coincides with the uppermost zone of low gamma-ray flux. Outside this section differences between deep and shallow resistivity values range from 0 to 20 ohm-m. The density log indicates average densities of 2.35 to 2.5 g/cm³. The sonic log indicates average interval transit times of 90 to 93 μ s/foot for sedimentary rocks in this interval and 57 to 77 μ s/foot for igneous rocks.

No in situ fossils material or environmentally diagnostic sedimentary structures were observed in this interval. This interval is tentatively considered to have been deposited in a marine environment.

Nothing in the petrology of the igneous rocks of this interval enables a determination to be made as to whether they were emplaced as surface flows or hypabyssal intrusions. However, the holocrystalline textures that predominate in cuttings and sidewall core samples of the igneous rocks are difficult to associate with submarine eruption. The sedimentary rocks in this interval are Oligocene or older (see Paleontology and Biostratigraphy section of this report). If the radiometric age of 19.9 m.y. derived from an igneous sample is correct, then the volcanic rocks must be intrusive (see radiometric age subsection below).

10,640 to 12,235 feet

The interval from 10,640 to 12,235 feet is characterized by sandstones and mudstones that are lithologically similar to those of the two units above. Conventional cores 7, 8, and 9 are from this interval and are described in figures 25, 26, and 27. Much of the sandstone is in thin, graded beds. Many of these are topped with siltstone or mudstone and may be described as Tbcd Bouma sequences (Bouma, 1962). Thicker sandstone beds associated with these Bouma sequences in cores 7 and 8 are similar to those of the Mutti-Ricci Lucchi facies C (Mutti and Ricci Lucchi, 1972). Some beds in core 8 have flame structure developed along their bases. Shale rip-up clasts and partings, and coal fragments, stringers, and lenses are scattered in the thicker, more massive sandstone beds. There are some burrows in core 7.

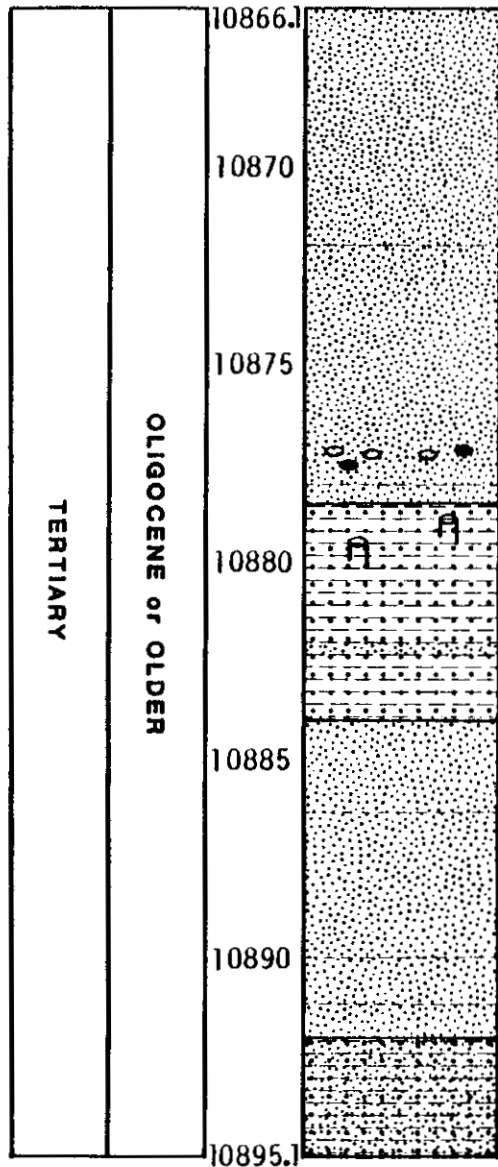

Sandstone, olive-gray (5Y 4/1), very fine grained, slightly micaceous, contains few scattered shale stringers and laminations and minor carbonaceous debris with concentration of shale rip-up clasts and coal fragments near base.

Mudstone, black (N-1), laminated with scattered very fine sandstone laminae and thin beds, locally burrowed.

Sandstone, olive-gray (5Y 4/1), very fine grained, slightly micaceous, contains few scattered shale stringers and laminations.

Mudstone and sandstone, lithologies as above in alternating 0.5- to 13-cm layers.

10.0	0.22		
10.6	0.24		
10.4	0.24		
10.9	0.29		
11.7	0.38		
10.9	0.31		
9.1	0.13		
10.1	0.18		
8.6	0.11		
7.4	0.07		
9.5	0.13		
9.7	0.16		
10.5	0.22		
8.0	0.09		
7.8	0.07		
10.0	0.11		
9.7	0.16		
10.1	0.14		
9.9	0.16		
8.4	0.11		
8.3	0.04		
9.0	0.09		
9.3	0.09		
9.3	0.13		
8.9	0.07		
9.9	0.10		
9.7	0.11		
10.2	0.09		
2.9	0.02		
9.1	0.07		
8.8	0.07		
8.3	0.10		
Porosity (Percent)			
Permeability (Millidarcies)			
Total Organic Carbon (Percent)			
Vitrinite Reflectance (Percent)			

Figure 25. Description of conventional core 7, Norton Sound COST No. 1 well [Geochemical Analyses by Data Core Laboratories, Inc.]

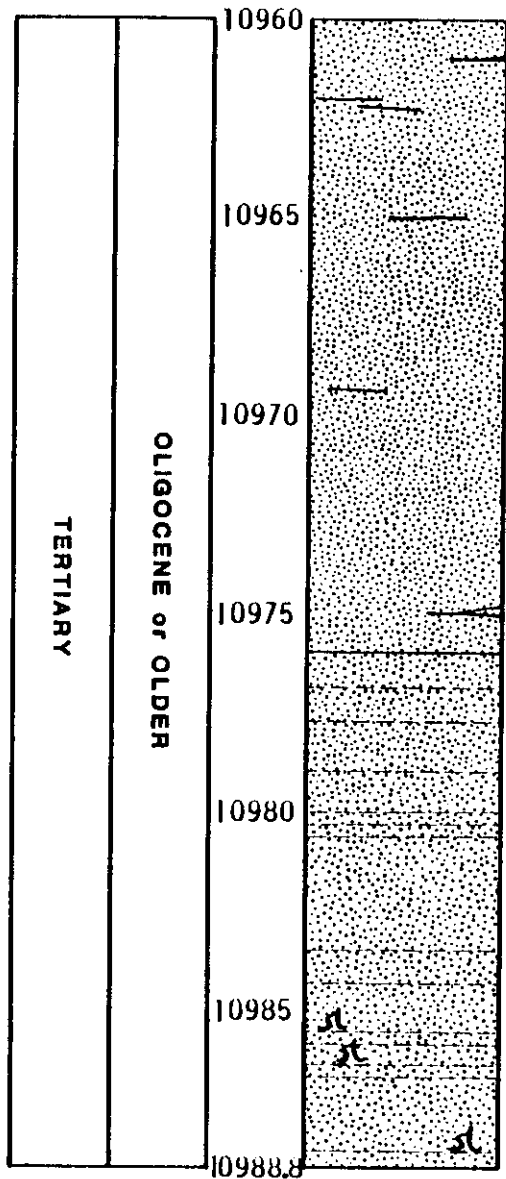

Sandstone, brownish-gray (5YR 4/1), fine to very fine grained, massive to weakly laminated with sparse shale partings and one coal lens at 10961.1 feet.

Sandstone, thin beds as above with interbedded sandy mudstone and graded very fine sandstone to mudstone couplets, flame structure along the bases of some beds.

Explanation
A-burrow
Q-bivalve
⊙-gastropod
λ-flame structure
p-pyrite
∟-cross-bedding

10.5	0.20		
11.6	0.22		
10.7	0.24		
10.7	0.18		
10.8	0.22		
10.2	0.25		
11.4	0.26		
11.6	0.26		
9.0	0.28		
11.0	0.09		
11.1	0.19		
12.3	0.21		
12.3	0.28		
10.3	0.19		
9.9	0.14		
9.9	0.14		
10.9	0.17		
10.9	0.21		
10.9	0.23		
10.6	0.16		
10.6	0.21		
9.8	0.16		
11.1	0.28		
9.2	0.14		
8.8	0.12		
8.6	0.07	1.39	0.66
10980			
7.3	0.05		
9.2	0.09		
8.0	0.07		
9.8	0.09		
9.8	0.09		
4.9	0.02		
7.9	0.05		
8.7	0.07		
8.6	0.05		
7.6	0.07		
Porosity (Percent)	Permeability (Millidarcies)	Total Organic Carbon (Percent)	Vitrinite Reflectance (Percent)

Figure 26. Description of conventional core 8, Norton Sound COST No. 1 well [Geochemical Analyses by Data Core Laboratories, Inc.]

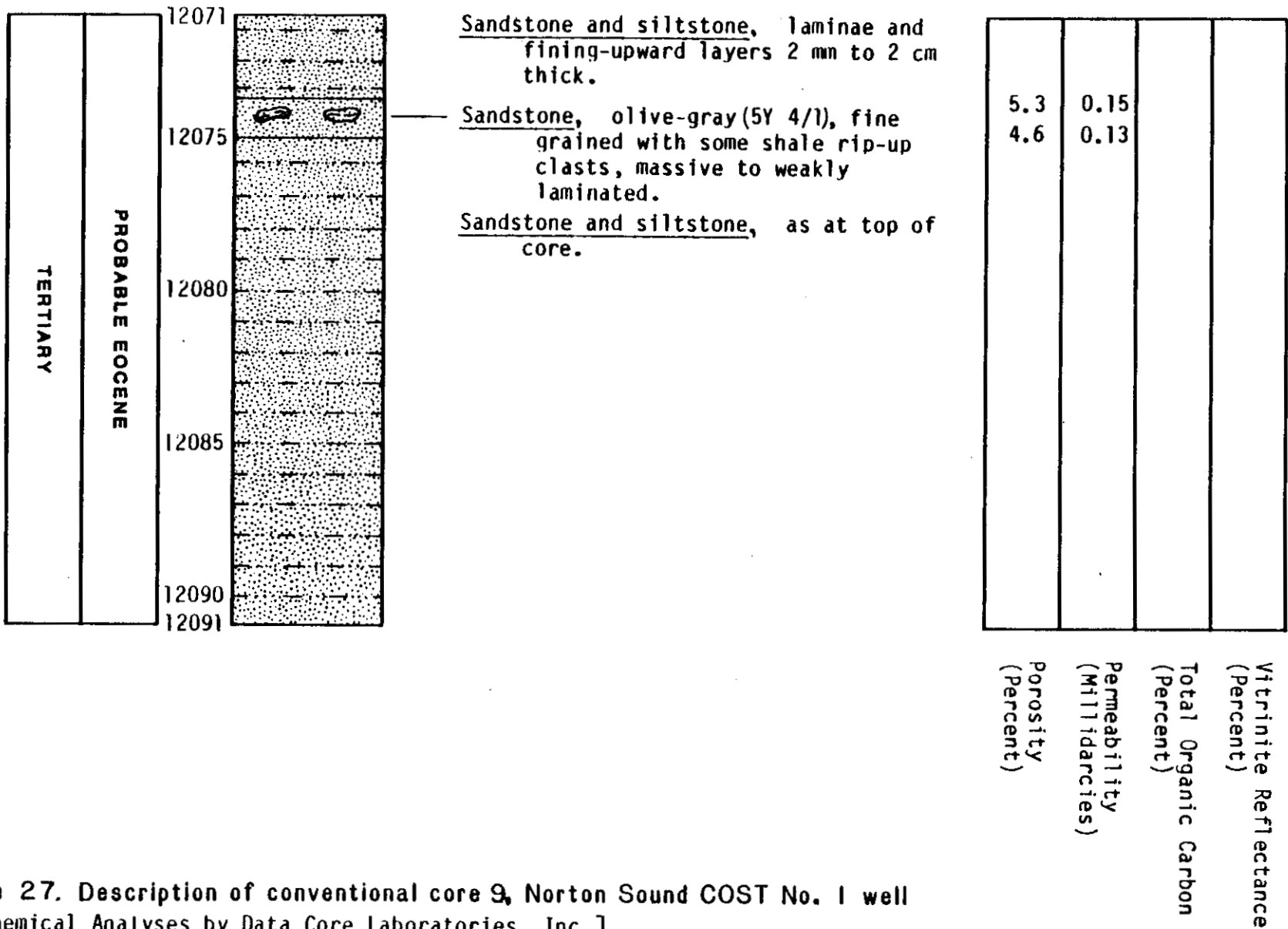

Figure 27. Description of conventional core 9, Norton Sound COST No. 1 well [Geochemical Analyses by Data Core Laboratories, Inc.]

The same combination of ductile grain deformation and authigenic cementation that affected intergranular space in the sandstone in the two intervals above obtains in the sandstone of this interval. Intergranular porosity in this sandstone is also similar to that described from sandstones in the shallower intervals. Porosity reaches 27.9 percent and permeability 0.38 mD in sidewall cores from this interval. However, in 71 samples from conventional cores, where fabric disruption in sampling is less likely than in sidewall cores, porosity ranges from 2.9 to 11.9 percent (with all but three values higher than 5 percent), and permeability ranges from 0.02 to 0.38 mD.

The SP log curve is erratic and cannot be meaningfully interpreted. The gamma-ray log curve defines numerous sandstone beds from 10 to more than 100 feet thick. There is approximately about 720 feet of sandstone in this 1595-foot interval. The resistivity log continues smoothly into this interval from the interval above. The overall blocky character of the resistivity curves reflects the presence of the thick sandstone beds indicated on the gamma-ray log, and a separation of around 10 ohm-m is common between the deep and shallow resistivity curves in the sandstone beds. The density log curve has the same variable character it had in shallower intervals. The extreme density values are 2.17 and 2.87 g/cm³ and the average values range from 2.5 to 2.8 g/cm³. The density log indicates porosities of 0 to 9 percent for sandstone in this interval.

The sonic log is less variable than the density log in this interval and has a generally blocky character. Lower interval transit times are associated with sandstone beds. The total range of interval transit times is 55 to 105 μ s/foot, but the average values are between 67 and 87 μ s/foot. The sonic log indicates porosities of 6 to 18 percent for sandstone in this interval.

No marine fossils were recovered. However, the presence of thin Bouma sequences among thicker massive sandstone beds and flame structures at the bases and preserved burrows at the tops of some beds indicate deposition of at least part of the interval by turbidity currents below wave base in a subaqueous environment.

12,235-12,545 feet

The interval from 12,235 to 12,545 feet is characterized by interbedded sandstone, siltstone, shale, coal, and conglomerate. Conventional core 10 is from this interval and is described in Figure 28.

Sandstone is very poorly sorted. Coarser framework clasts consist predominantly of phyllite and fine-grained quartz-muscovite schist fragments. Considerable detrital sparry dolomite is present among the finer framework clasts. Quartz, most of which is polycrystalline, and chert are also present in the sandstone framework. Clasts are generally subangular, and orientation of elongate clasts commonly defines the lamination in the sandstone. The sandstone in core 10 contains some burrows.

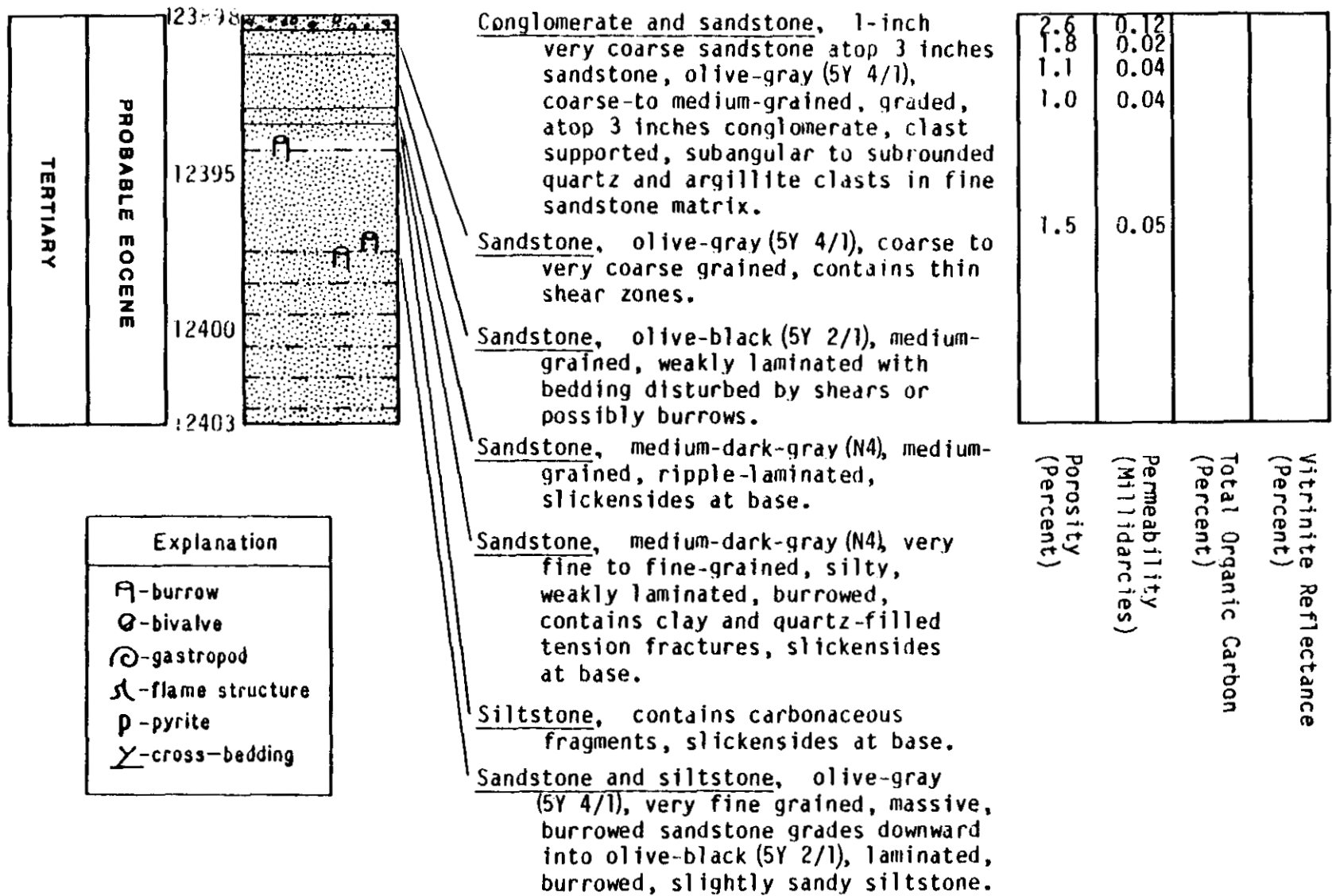

Figure 28. Description of conventional core IO, Norton Sound COST No. 1 well [Geochemical Analyses by Data Core Laboratories, Inc.]

There is no visible intergranular porosity in sandstone samples from this interval. Porosity reduction has been accomplished largely by ductile grain deformation, and intergranular space that has not been destroyed by ductile grain deformation is filled with authigenic kaolinite. The only other authigenic materials observed in sandstone from this interval are micritic siderite, which is locally present in rims on dolomite clasts, and quartz, which fills some tension fractures. Porosity in five samples from this interval, all from core 10, ranges from 1.0 to 2.6 percent, and permeability ranges from 0.02 to 0.12 mD in the same samples.

Siltstone and conglomerate in this interval differ from the sandstone only in grain size. The conglomerate consists of predominantly metamorphic and quartz pebbles in a sandstone matrix. The shale is micaceous and carbonaceous, and the orientation of mica flakes and carbonaceous debris defines fissility. Coal is abundant in cuttings.

The SP curve is erratic in this interval and cannot be meaningfully interpreted. The gamma-ray log indicates a maximum bed thickness of about 10 feet for the various lithologies that are interbedded in this interval. The resistivity log curve is extremely variable through this interval. The highest resistivity values are at depths with low measured gamma radiation and are

interpreted as coal beds. Depths with low gamma radiation and lower resistivity are interpreted to be sandstone beds. The density log curve is also extremely variable through this interval. Very low densities are correlative with coal beds. The density log indicates porosities of from 0 to 4 percent for sandstones in the interval. Except in coal beds, where interval transit times are high, the sonic log shows a general decrease of interval transit time through this interval from around 75 μ s/foot near the top to around 55 μ s/foot near the base. The sonic log indicates porosities of 1 to 6 percent for sandstone beds.

This coal-bearing sedimentary sequence was deposited in a fluvial or deltaic environment.

12,545-14,683 (TD)

The interval from 12,545 feet to the bottom of the well is characterized by cataclastically metamorphosed sedimentary rocks with some cataclastic marble. Conventional cores 11 and 12 are from this interval and are described in figures 29 and 30.

The cataclastically metamorphosed rocks include mylonite and cataclastite in which the matrix consists of granulated rock. Pyrite is commonly concentrated along well-developed fluxion banding. Within the matrix there are scattered coarse-sand- to pebble-size angular fragments and flasers of sandstone, siltstone, schist, phyllite, quartz, and chert. Very finely crystalline carbonate is present in the matrix locally, and sparry calcite has partly replaced matrix

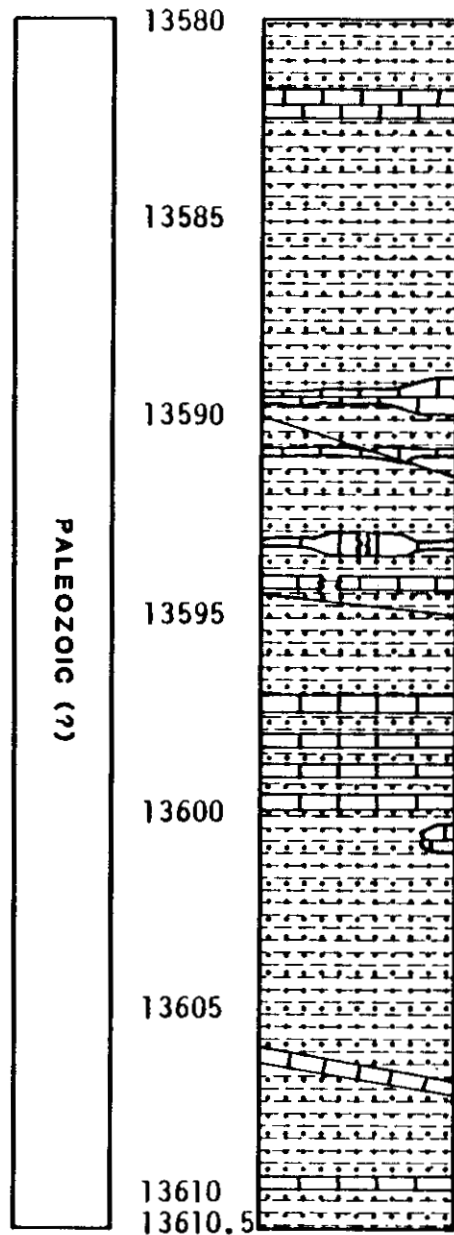

Cataclastite, black (N1), fluxion-banded, cataclastic mudstone with numerous folia to 1 cm of medium-light-gray (N6), very fine grained, cataclastic sandstone; several 5- to 20-cm-thick, coarsely crystalline calcite layers generally parallel fluxion structure and folia; calcite layers are locally disrupted by tension gashes, and some calcite bondins are present; faults cut the core around 13591, 13595, and 13606 feet; calcite occupies open space in fault plane near 13606 feet; fluxion structure is sigmoidally folded between 13593.5 and 13593.8 feet and kink folded at base of core; sandy folia are not present below 13606 feet.

--	--	--	--

Vitrinite Reflectance
(Percent)
Total Organic Carbon
(Percent)
Permeability
(Millidarcies)
Porosity
(Percent)

Figure 29. Description of conventional core 11, Norton Sound COST No. 1 well [Geochemical Analyses by Data Core Laboratories, Inc.]

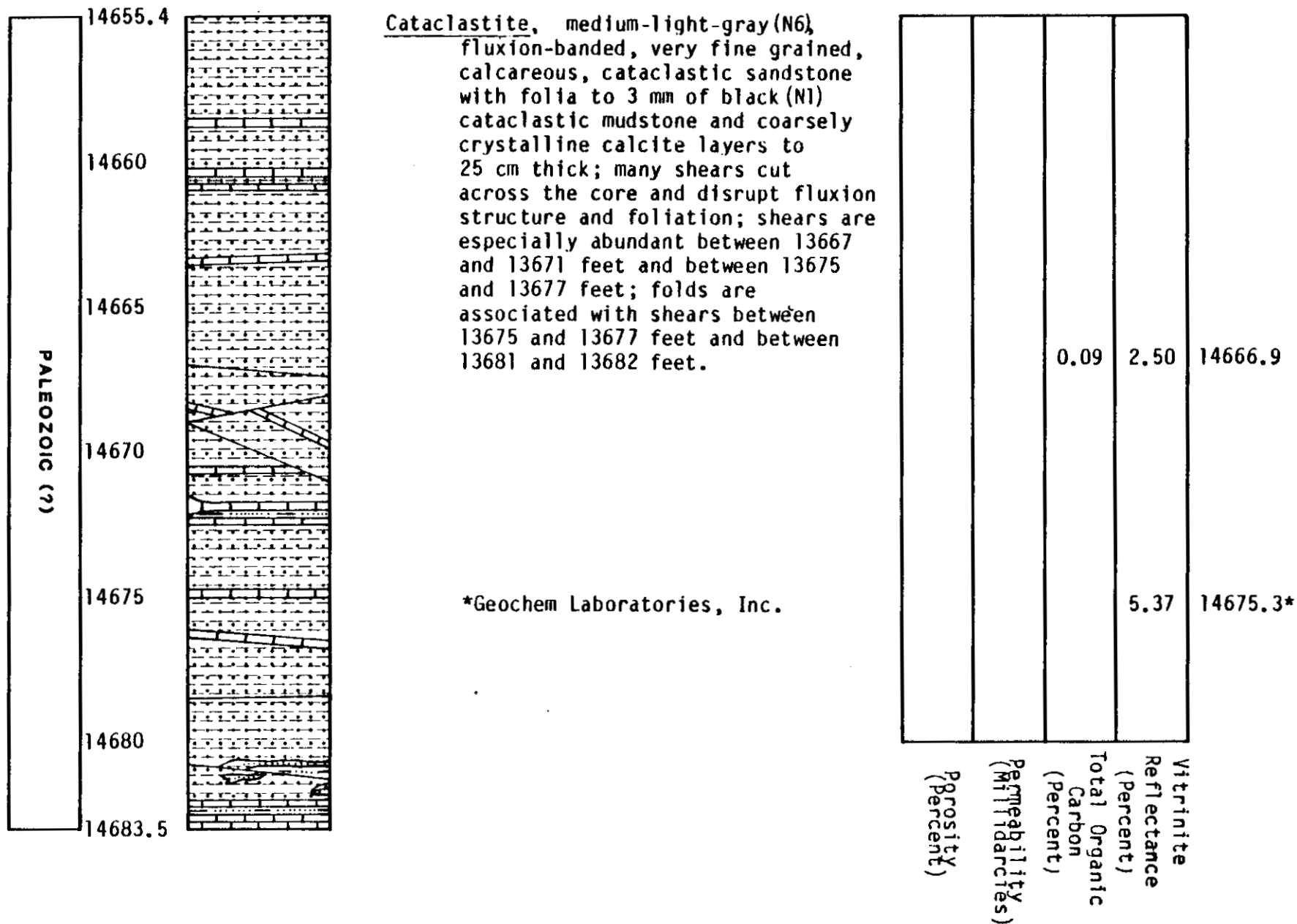

Figure 30. Description of conventional core 12, Norton Sound COST No. 1 well

partly and rock fragments or flasers. A few scattered pressure shadows are filled with authigenic kaolinite. There is no visible porosity in these rocks. The cataclastic marbles are very finely to coarsely crystalline. Boundaries between carbonate grains are commonly sutured. The presence of quartz grains or argillaceous material locally defines a foliation in the the marble. Numerous deformational features including faults, tension gashes, folds, and boudins are present in the conventional cores from this interval.

The SP curve wanders and cannot be interpreted. The gamma-ray curve is blocky on a large scale and suggests segregation of shaly from nonshaly lithologies. Resistivities are high, and shallow resistivity is commonly from 20 to several 100 ohm-m higher than deep resistivity. The density log indicates densities of from 2.7 to 2.75 g/cm³ throughout this interval. The sonic log shows little variation and indicates interval transit times of from 55 to 65 μ s/foot.

Porosity and Permeability

Porosity and permeability determinations for samples from sidewall and conventional cores are presented in Table 2, and porosity and permeability data from sandstone samples are presented graphically in Plate 1. Because of

Table 2. POROSITY AND PERMEABILITY
Norton 1
[from Core Laboratories, Inc.]

Depth (feet)	Lithology	Porosity (Percent)	Permeability (Millidarcies)	Remarks
4736.0	ss;vfgr slty sl calc	28.7	9.41	Sidewall
5322.0	ss;vf-mgr slty	22.5	10.	Sidewall
6749.0	sltst;sl sdy	10.0	0.60	Sidewall
7149.0	ss;vfgr shy sid	18.1	0.90	Sidewall
7330.0	ss;vf-fgr	19.1	21	Sidewall
7562.0	ss;vf-fgr slty	23.6	3.77	Sidewall
7681.0	same;sl calc	20.7	2.51	Sidewall
7712.0	sltst;vsdy sid	16.7	0.90	Sidewall
7752.0	ss;vf-fgr shy	22.8	5.10	Sidewall
7824.0	same	19.2	2.60	Sidewall
7878.0	same;vcalc	19.2	0.80	Sidewall
7943.0	ss;vf-fgr sl calc sc pyr	22.3	0.30	Core 4
7944.0	same	21.7	0.36	Core 4
7945.0	same	21.1	0.30	Core 4
8066.0	sltst;sl sdy	14.8	<0.01	Sidewall
8180.0	same	14.4	<0.01	Sidewall
8230.0	same	16.8	0.04	Sidewall
8286.0	same	16.8	0.06	Sidewall
9440.0	sh	9.6	<0.01	Sidewall
9531.0	same	10.6	<0.01	Sidewall
9626.0	same	13.9	<0.01	Sidewall
9983.0	ss;vfgr slty	23.9	18	Sidewall
10312.0	sltst;sdycalc	20.4	1.70	Sidewall
10346.0	ss;vf-cgr cly	17.3	1.20	Sidewall
10374.0	ss;vf-mgr slty	19.2	27.	Sidewall
10381.0	sh;carb lam	12.1	1.01	Sidewall
10426.0	ss;vf-mgr fos	20.4	5.32	Sidewall
10652.0	sh;sdyc mica	6.3	<0.01	Sidewall
10786.0	same;carb	2.7	<0.01	Sidewall
10866.6	ss;vf-mgr mica sl calc	10.0	0.22	Core 7
10867.2	same	10.6	0.24	Core 7
10867.8	same	10.4	0.24	Core 7
10868.6	same	10.9	0.29	Core 7
10869.2	same	11.7	0.38	Core 7
10869.7	same	10.9	0.31	Core 7
10870.2	same	9.1	0.13	Core 7
10870.7	same	10.1	0.18	Core 7
10871.5	same	8.6	0.11	Core 7
10872.4	same	7.4	0.07	Core 7
10872.9	same	9.5	0.13	Core 7

Table 2. POROSITY AND PERMEABILITY
Norton 1

Depth (feet)	Lithology	Porosity (Percent)	Permeability (Millidarcies)	Remarks
10873.6	same	9.7	0.16	Core 7
10874.3	same	10.5	0.22	Core 7
10875.2	same	8.0	0.09	Core 7
10875.8	same	7.8	0.07	Core 7
10876.5	same	10.0	0.11	Core 7
10881.9	same	9.7	0.16	Core 7
10884.5	same	10.1	0.14	Core 7
10885.5	same	9.9	0.16	Core 7
10885.8	same	8.4	0.11	Core 7
10886.2	same	6.3	0.04	Core 7
10886.9	same	9.0	0.09	Core 7
10887.8	same	9.3	0.09	Core 7
10888.6	same	9.3	0.13	Core 7
10889.3	same	8.9	0.07	Core 7
10889.6	same	9.9	0.10	Core 7
10890.5	same	9.7	0.11	Core 7
10891.7	same	10.2	0.09	Core 7
10892.5	ss;vfgr vcarb mica	2.9	0.02	Core 7
10892.8	ss;vf-mgr mica sl calc	9.1	0.07	Core 7
10893.4	same	8.8	0.07	Core 7
10894.9	same	8.3	0.10	Core 7
10916.0	ss;vf-fgr carb	17.7	1.64	
10960.2	ss;vf-mgr mica sl calc	10.5	0.20	Core 8
10960.8	same	11.6	0.22	Core 8
10961.3	same	10.7	0.24	Core 8
10961.9	same	10.7	0.18	Core 8
10962.5	same	10.8	0.22	Core 8
10963.3	same	11.2	0.25	Core 8
10963.8	same	11.8	0.26	Core 8
10964.5	same	11.4	0.26	Core 8
10964.9	same	11.6	0.28	Core 8
10965.9	same	9.0	0.09	Core 8
10966.7	same	11.0	0.19	Core 8
10967.2	same	11.1	0.21	Core 8
10967.8	same	12.3	0.28	Core 8
10968.6	same	11.3	0.19	Core 8
10969.2	same	10.2	0.14	Core 8
10969.6	same	9.8	0.14	Core 8
10970.3	same	11.9	0.28	Core 8
10970.6	same	9.7	0.17	Core 8

Table 2. POROSITY AND PERMEABILITY
Norton 1

Depth (feet)	Lithology	Porosity (Percent)	Permeability (Millidarcies)	Remarks
10971.2	same	10.9	0.21	Core 8
10971.6	same	11.9	0.23	Core 8
10972.2	same	10.5	0.16	Core 8
10972.7	same	10.6	0.21	Core 8
10973.7	same	9.8	0.16	Core 8
10974.4	same	11.1	0.28	Core 8
10974.9	same	9.2	0.14	Core 8
10975.6	same	8.8	0.12	Core 8
10977.5	same	8.6	0.07	Core 8
10981.6	same	7.3	0.05	Core 8
10982.3	same	9.2	0.09	Core 8
10983.2	same	8.0	0.07	Core 8
10984.2	same	9.8	0.09	Core 8
10984.8	same	9.8	0.09	Core 8
10985.8	same	4.9	0.02	Core 8
10986.8	same	7.9	0.05	Core 8
10987.6	same	8.7	0.07	Core 8
10988.1	same	8.6	0.05	Core 8
10988.8	same	7.6	0.07	Core 8
11050.0	ss;vf-cgr sl calc muddy	27.6	14	
11274.0	same	27.9	8.43	Sidewall
11350.0	same	16.6	1.92	Sidewall
11426.0	sltst;vmuddy	16.8	<0.01	Sidewall
11577.5	same	13.5	<0.01	Sidewall
11673.0	same	16.1	<0.01	Sidewall
11850.0	ss;f-cgr sl calc	20.8	36	Sidewall
11900.0	ss;f-cgr	22.3	26	Sidewall
12004.0	sltst;sl sdy	12.9	<0.01	Sidewall
12065.0	same	10.7	<0.01	Sidewall
12073.8	ss;vf-mgr mica	5.3	0.15	Core 9
12074.6	same	4.6	0.13	Core 9
12140.0	sh	4.8	<0.01	
12390.0	sltst	2.6	0.12	Core 10
12390.7	same	1.8	0.02	Core 10
12391.7	same	1.1	0.04	Core 10
12392.0	same	1.0	0.04	Core 10
12397.0	same	1.5	0.05	Core 10

irregular sample distribution, porosity and permeability values have been integrated over 500-foot thicknesses and are represented by symbols that show the mean value and range for each such interval. The number of sandstone samples in each interval is given under the applicable symbol. Sandstone porosities from sidewall cores above 8000 feet are in good agreement porosities from deeper sidewall cores are considerably higher than from nearby conventional cores and are probably spurious. The decrease in porosity with depth for sandstone samples from the well is shown graphically in Figure 31. The curve is a visually estimated best fit based on all sandstone-porosity data from above 8000 feet and all conventional core sandstone-porosity data from below 8000 feet.

Throughout the well, sandstone permeabilities from sidewall cores are commonly significantly higher than from nearby conventional cores. This discrepancy is undoubtedly a result of fabric disruption attendant on the sidewall-coring process. The relationship between porosity and permeability of sandstone samples from conventional cores, where such fabric disruption is not a significant factor, is shown graphically in Figure 32. Sandstone in this well must have at least 24 percent porosity to have even 1 mD permeability (Figure 32). Figure 31 shows that sandstone porosities of more than 24 percent are restricted to depths of less than 6000 feet in the well.

Pore reduction in these rocks is caused by a combination of ductile grain deformation and authigenic cementation. Ductile grain deformation involves the squeezing of softer clasts such as the common metamorphic rock fragments

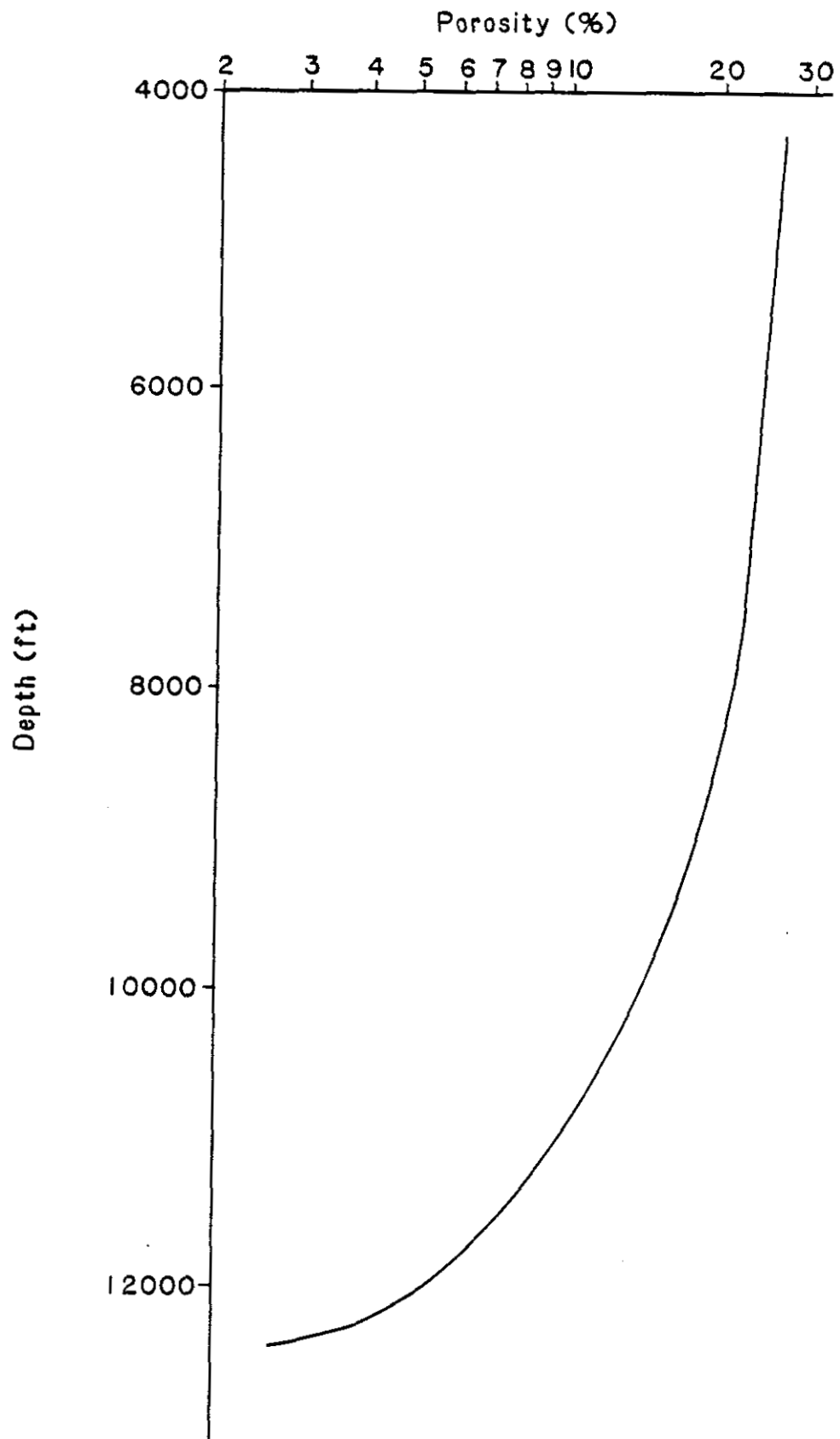

Figure 31. Plot of average porosity against depth for conventional core sandstone samples from Norton Sound COST No.1 well.

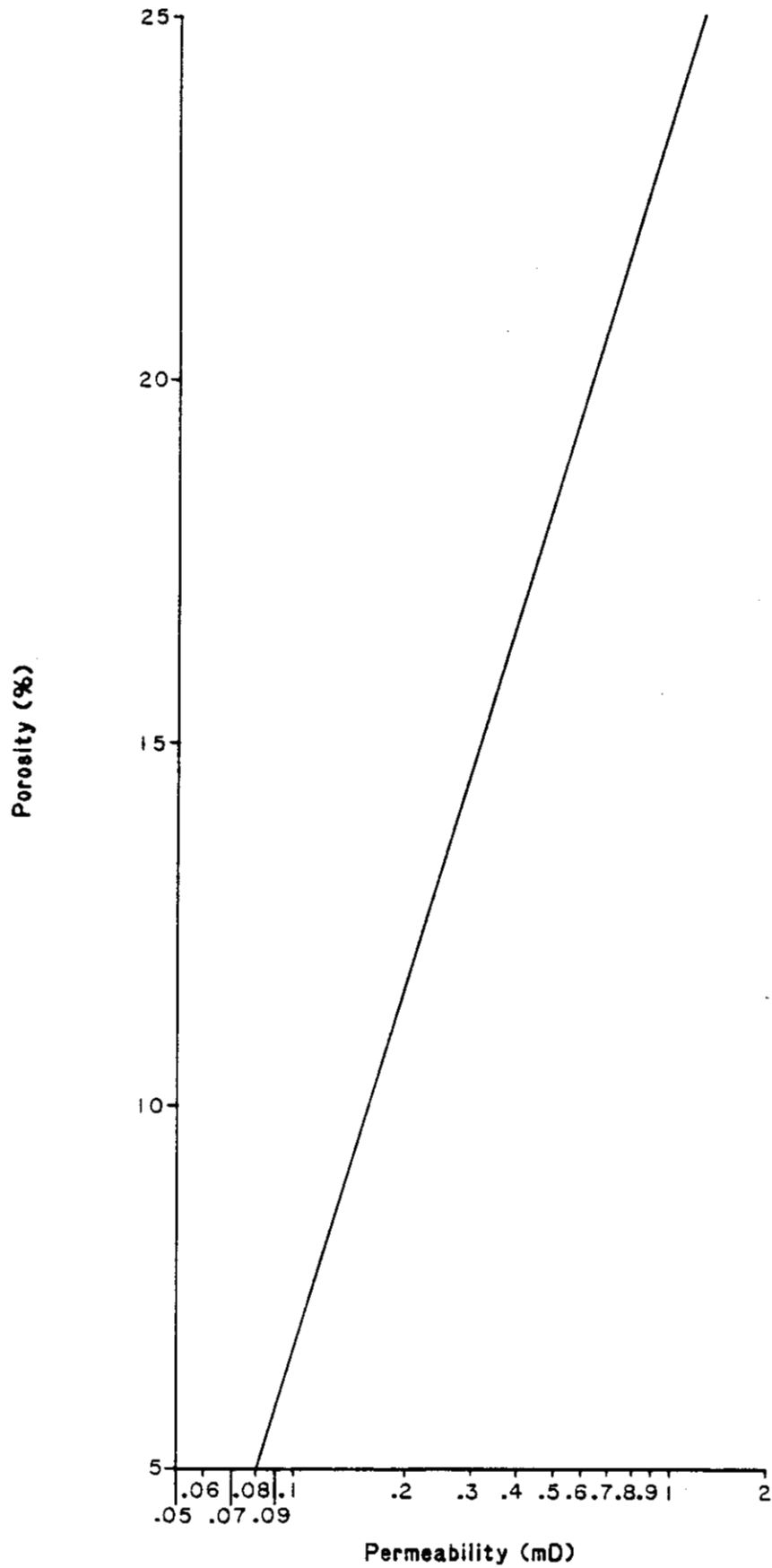

Figure 32. Plot of average permeability against average porosity for conventional core sandstone samples from Norton Sound COST No.1 well.

into open spaces between harder clasts as a response to increasing burial pressure. Growth of authigenic cements is a response of the solution-solid system to changes in temperature, pressure, and fluid composition. Authigenic phases include pyrite, siderite, smectite, calcite, kaolinite, and quartz. Pyrite, which is present locally as small framboids and intergranular cement, and siderite, which is commonly micritic, are the earliest authigenic cements to have formed. The shallowest observed sites of these cements are in samples from 1328 and 1537 feet for pyrite and siderite respectively. The shallowest observed authigenic smectite is in a sample from 4167 feet. This clay commonly forms rims on framework clasts in sandstone, and the clay platelets in the rims are commonly arrayed normal to clast surfaces. Considerable micro-porosity can exist among authigenic clay platelets. Sandstones in which intergranular spaces are completely filled with clay commonly display fairly high porosities on testing. Permeability is extremely low in such rocks, however. Authigenic calcite is present as sparry cement and locally replaces detrital and other authigenic materials. The shallowest observed sparry calcite cement is from 7330 feet. Some samples contain up to 20 percent sparry calcite cement. In some samples from 9983-12,200 feet, secondary porosity has formed by dissolution of sparry calcite cement. Authigenic quartz cement is present in these samples. The shallowest observed authigenic kaolinite is from 7562 feet.

Kaolinite comprises no more than 2 percent of any sample and is present in decussately arrayed vermicular stacks which fill or partly fill intergranular spaces or, less commonly, fractures. Authigenic quartz was observed only in samples from 9983 to 12,200 feet, where it is present as syntaxial overgrowths on quartz clasts. Except for the formation of secondary porosity by calcite dissolution, all diagenetic changes observed in sandstones from the well have reduced reservoir potential.

Radiometric Age Determinations

Thirteen potassium-argon age determinations were made on rocks from 5012 to 14,671.8 feet (Table 3). All but one of the age determinations were made on sedimentary and cataclastic metasedimentary rocks. Of these, two were made on whole rocks and ten on concentrations of detrital muscovite. The ages thus obtained reflect the age of the source areas rather than the depositional age. The ages were separated into two groups with a break between 10,397 and 10,893 feet. Ages obtained from sedimentary rocks above 10,397 feet range from 81 to 104 m.y., and ages from sedimentary and metasedimentary rocks below 10,893 feet range from 125 to 206 m.y. with most between 141 and 151 m.y.

A single age determination was made on a sample of igneous rock found loose and probably out of place on top of conventional core 6. This determination was made on a feldspar concentrate, which yielded measured contents of 5.818

TABLE 3. Potassium-argon age determinations

[from Geochron Laboratories Division of Krueger Enterprises, Inc.]

<u>Depth (feet)</u>	<u>Lithology</u>	<u>Material Tested</u>	<u>Age (x 10⁶ years)</u>
5012	shale	muscovite concentrate	84.2 \pm 3.6
6220	shale	muscovite concentrate	99.7 \pm 4.1
7942	shale	muscovite concentrate	81.3 \pm 3.4
9750	shale	muscovite concentrate	104 \pm 4
rubble found atop Core 6	volcanic rock	feldspar concentrate	19.9 \pm 0.8
10397	shale	muscovite concentrate	81.3 \pm 3.3
10893	arkose	muscovite concentrate	141 \pm 5
10964	arkose	muscovite concentrate	151 \pm 6
12074	arkose	muscovite concentrate	147 \pm 6
12398	arkose	muscovite concentrate	146 \pm 6
13583	shale	whole rock	206 \pm 10
14658	shale	whole rock	148 \pm 7
14671.65-14671.8	phyllite	muscovite concentrate	125 \pm 5

and 5.662 weight percent potassium on duplicate analyses. These analyses indicate the presence of potassium feldspar diluted with some other material in the concentrate. Potassium-argon ages based on potassium feldspar other than sanidine, or on plagioclase with more than about 2 percent potash content, are generally considered unreliable (F. H. Wilson, oral communication). As neither the type of potassium feldspar nor the nature of the other material present in the dated concentrate were determined, the 19.9 ± 0.8 m.y. age cannot be considered definitive. Patton and Csejtey (1971) have reported potassium-argon ages of 62.8 ± 1.8 m.y. on hornblende from a trachyte flow on St. Lawrence Island near the well site.

Geochemistry

Norton COST Well 1

by Tabe O. Flett

Introduction

The geochemistry program for the No. 1 well was designed to evaluate the petroleum potential of rocks in western Norton Sound and to identify, the specific source-rock intervals capable of producing hydrocarbons. The operator of the well authorized Core Laboratories, Inc., of Dallas, Texas, and Geochem Laboratories, Inc., of Houston, Texas, to perform geochemical analyses.

Cuttings were taken at 60-foot intervals from 240 to 14,667 feet. The cuttings were placed in one-quart cans with a bactericide and sealed with press-on lids. Fifty nine sidewall cores, eight conventional cores, and twelve drilling mud samples were also collected for analysis. The final conventional core produced samples from 14,679 feet. Analyses were performed for visual kerogen, thermal alteration index, random vitrinite reflectance, organic carbon content, C₁ - C₇ hydrocarbons, C₁₅+ extract and hydrocarbon content, and carbon isotope content of the extracts. Gas chromatography and rock-eval pyrolysis were also

performed. The original data is on file at the Minerals Management Service, 800 A. Street, Anchorage, Alaska 99501, and is available for examination.

Geothermal Gradient

The apparent mean geothermal gradient for the No. 1 well was computed from raw data and is plotted on Figure 33. Observed temperatures from 2,000 feet to 14,660 feet (Bottom Hole Temperature, BHT) were taken from the high-resolution thermometer log.

Total Organic Carbon Content

Total organic carbon content (TOC) from cuttings, sidewall cores, and conventional cores analyzed by both Core Laboratories and Geochem Laboratories are displayed on Plate 1. The two laboratories used essentially the same analytical techniques. Samples were dried, pulverized, treated first with cold and then with hot hydrochloric acid, and analyzed in LECO carbon analysers. Blanks, standards, and duplicate samples were periodically analyzed. The two data sets are in good agreement.

From 1,260 to approximately 4,500 feet, the TOC increases linearly with depth from slightly less than 0.5 percent to about 1.1 or 1.2 percent. At 4,860 feet the first of several zones occur which exhibit anomalously high TOC values (2 percent to 52 percent). Anomalies in excess of two to three percent TOC are observed where coal is recovered in the cuttings in anything from trace amounts to 15 percent of the total lithology. From about 5,900 to 9,500 feet, TOC values decrease

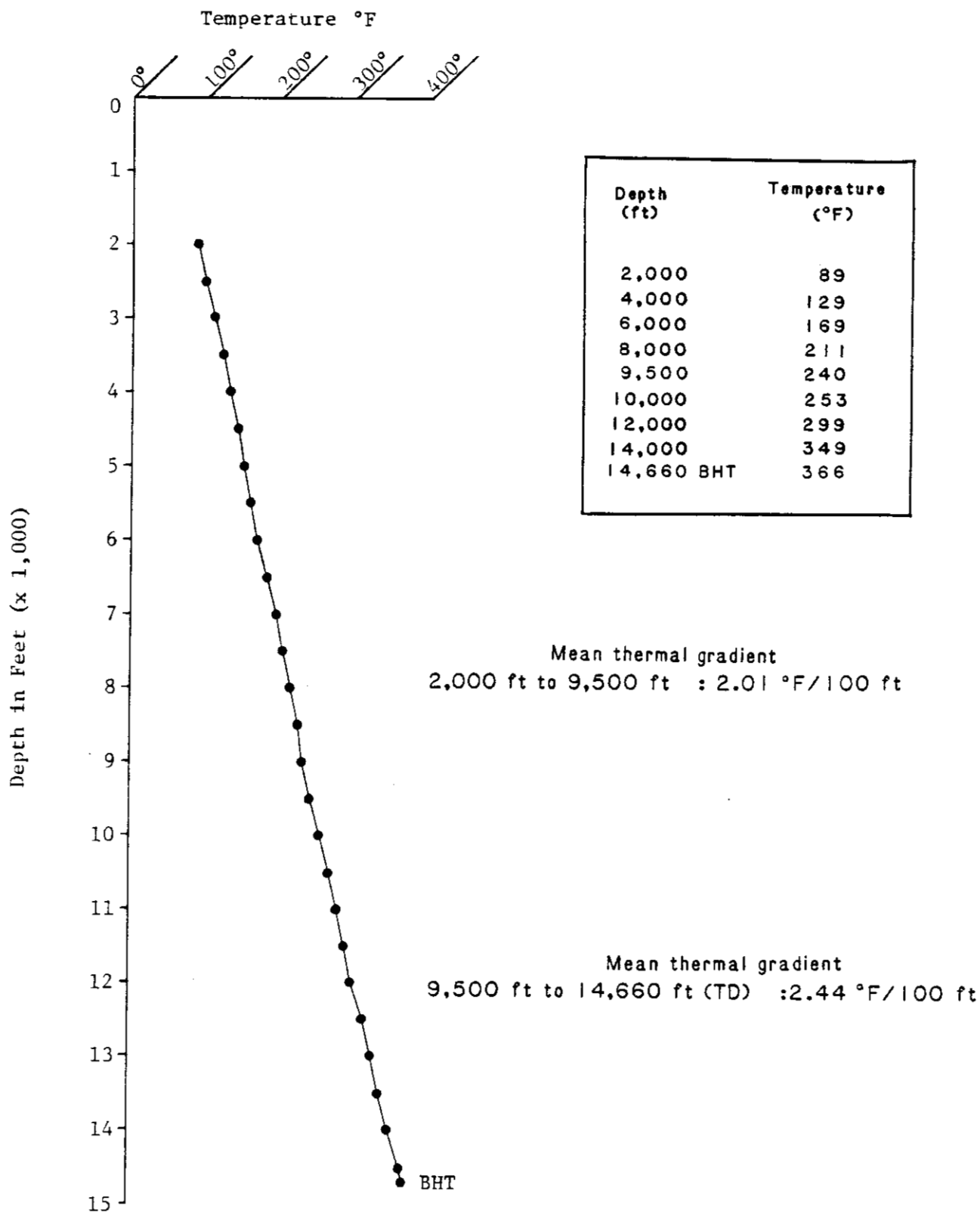

Figure 33. High-resolution thermometer data from COST Well 1, Norton Sound, 36 hrs after circulation ceased.

[Data from Schlumberger, Limited]

gradually from around one percent to approximately 0.8 percent. At 9,200 feet there are traces of coal with associated TOC values of 3 to 4 percent. From 9,500 to 13,000 feet, background organic carbon values are high, ranging generally between 1.0 and 2.0 percent, with very high values where coal occurs in the cuttings. Between 13,000 feet to the total depth of the well (14,683 feet), TOC values range between 0.2 and 0.5 percent with two exceptions which exceed 1.0 percent. It is important to know if TOC content has been influenced by the presence of coal in the samples and to what extent this is true if such contamination has occurred. Samples were carefully washed, and Dr. Bayliss (personal communication) of Geochem Laboratories is confident that coal is not a significant factor in the TOC analyses. However, the excessively high TOC values often appear when even trace amounts of coal occur in the cuttings.

Description of Kerogen

Microscopic examination of the kerogen present in potential source rock was performed by both Core Laboratories and Geochem Laboratories. The former applied the coal petrographer's reflected light technique and classification system. The latter used transmitted light and adopted the palynologist's classification. Results from these studies are displayed in Figure 34 with the hydrogen to carbon ratio (H/C).

From the surface to about 12,200 feet, the organic matter is generally humic, being composed predominantly of herbaceous and woody or vitrinitic and exinitic kerogen. The H/C ratios from this interval range from 1.087 to 0.739, which is characteristic of average values

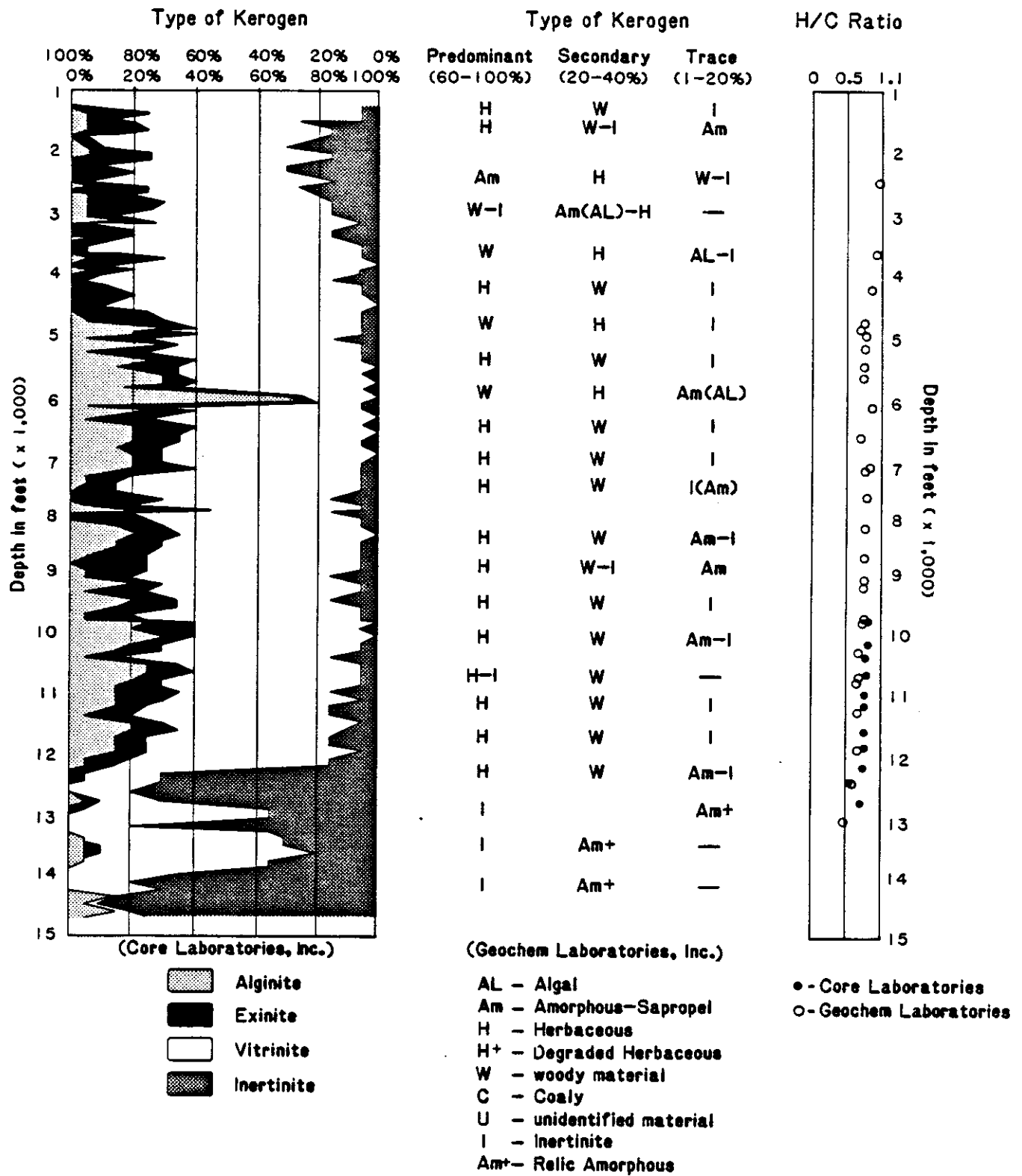

Figure 34. Classification of Organic Matter.

observed by Hunt (1979) for these kerogens. The average H/C ratios Hunt has published are approximately 1.2 for herbaceous kerogen and 0.72 for woody kerogen.

Elemental analyses for carbon, hydrogen, and oxygen are plotted on the Van Krevelen diagram, Figure 35. The distribution of these data indicates a kerogen somewhat richer in hydrogen than normal type III kerogen which is the geochemical expression of woody, herbaceous, vitrinitic organic material. Up to 20 percent of algal, amorphous, and exinitic kerogens are common to a depth of approximately 12,200 feet, and this potentially lipid-rich material may have produced slightly higher H/C ratios. However, an analogous plot of the hydrogen and oxygen indices from pyrolysis data yields little indication of anomalous hydrogen content. The kerogen's evolution path (fig. 36) is a textbook example of type III kerogen. The pyrolysis data is in better agreement with the microscopic descriptions of the kerogen than are the elemental analyses. Dow and O'Connor (1981) warn that low-rank coal contamination can cause anomalously high H/C ratios. Two of the pyrolysis analyses seem to have relatively higher hydrogen contents, which are characteristic of type II kerogen. These analyses may reflect the exinite microscopically observed.

Below 12,200 feet inertinite becomes the dominant kerogen type with significant percentages of vitrinite occurring locally. H/C ratios decrease to a minimum of 0.61 at 12,420 feet. Although this steady reduction in the H/C ratio probably reflects normal thermal maturation,

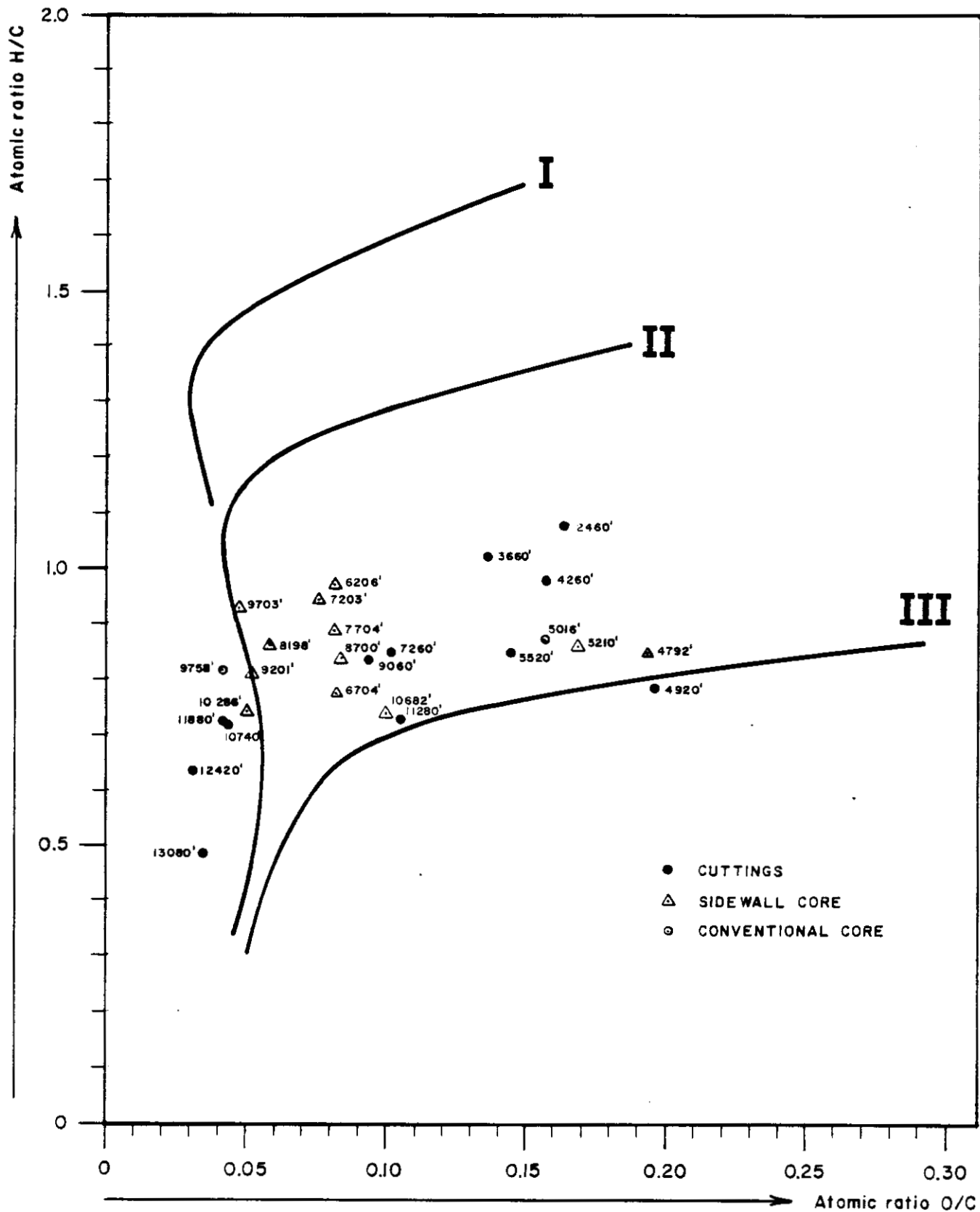

Figure 35. Van Krevelen diagram. Elemental analyses performed by Geochem Laboratories, Inc.

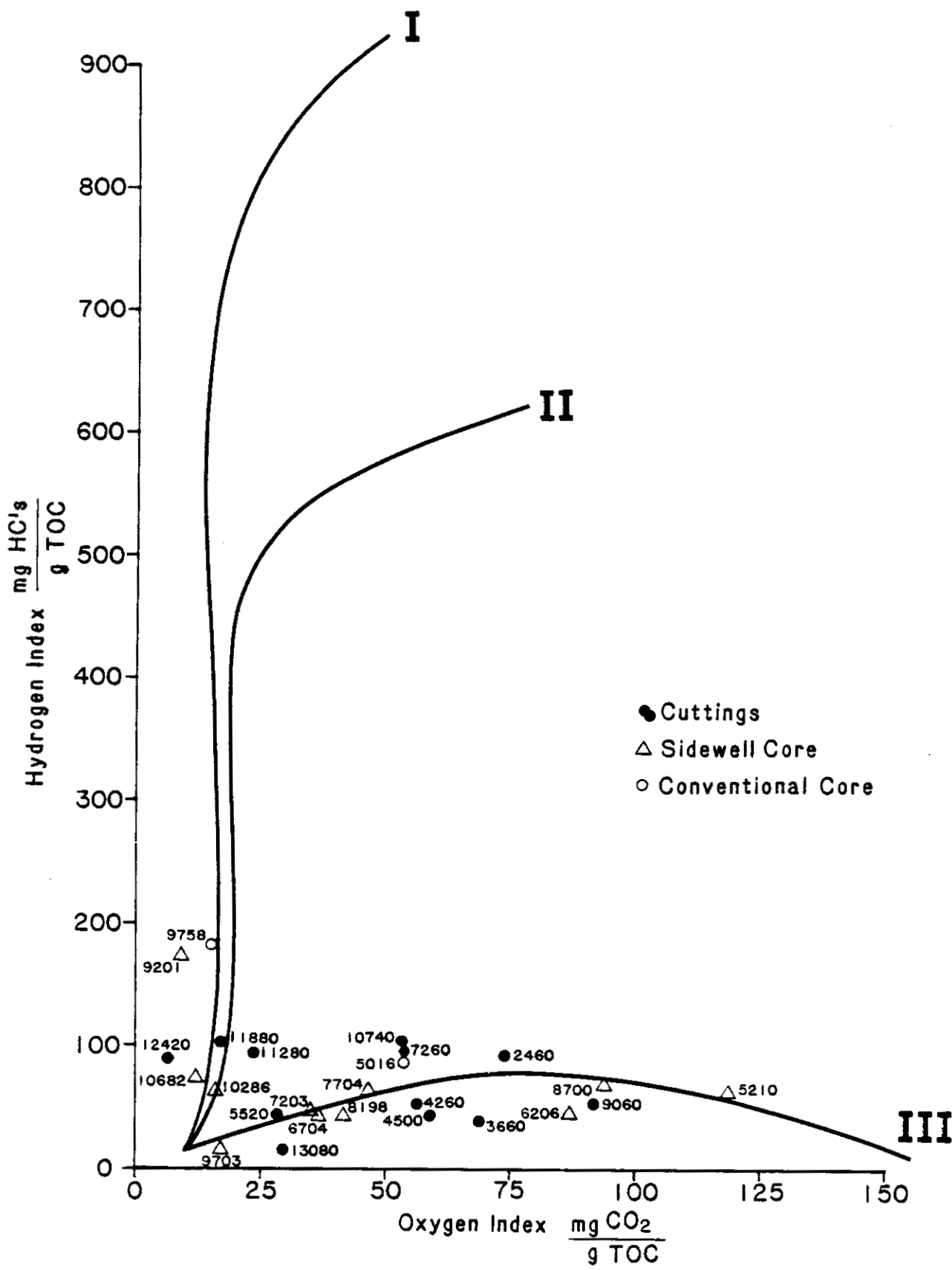

Figure 36. Van Krevelen Diagram.
 (Selected pyrolysis analyses by Geochem Laboratories, Inc.)

these reduced values are not inconsistent with measurements that Hunt (1979) considers to be representative of woody kerogen and inertinite (0.72 and 0.47 respectively). On the modified Van Krevelen diagram (fig. 36) the O/C level has decreased to where it is no longer possible to distinguish among the three principal kerogen types on the basis of a few isolated analyses at this level of maturity.

The kerogen below 13,000 feet does not contain significant amounts of organic carbon (plate 1) and the only H/C ratio observed at this depth was 0.504. It is unlikely that any hydrocarbons other than minor amounts of dry gas could be generated by this organic material.

Maturation

Thermal alteration index (TAI) and random vitrinite reflectance (Ro), the two most common measures of thermal alteration, are displayed in Figure 37, along with the carbon preference index (CPI), and the T₂-max °C values from the second pyrolysis response.

TAI values assessed by Geochem Laboratories are slightly less than Core Laboratories' estimates. On the scale adopted in this report a TAI of 2.2 is "moderately mature" and approximately equivalent to a random vitrinite reflectance of 0.6 percent. A TAI of 3.2 is "mature" and equal to an Ro of 1.3 or 1.4 percent. Metagenesis begins at an Ro of approximately 2.0 percent (Tissot and Welte 1978). This would be roughly equivalent to a TAI of 3.8.

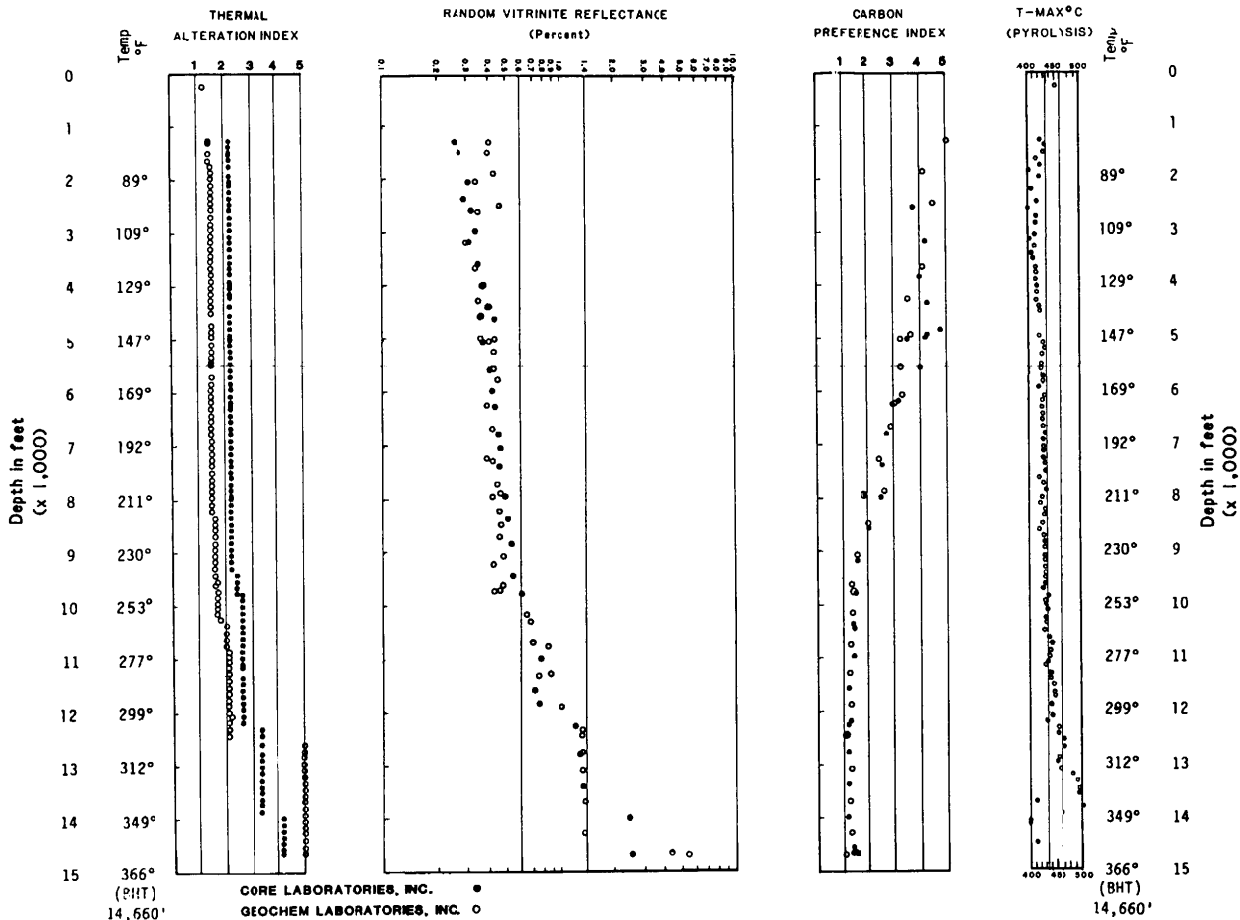

Figure 37. Selected indicators of thermal maturation

Random vitrinite reflectances measured by both laboratories agree. The number of measurements ranged from 4 to 105 with populations of 20 to 40 being most common. Several measurements from cuttings at 1,267, 1,860, and 2,460 feet and a sidewall core at 1,467 feet are anomalously high, but these averages were acquired from tiny populations with erratic distributions and are best discounted. At about 9,700 feet there is a discontinuity in the trend of the data. The R_o appears to increase stepwise across the threshold for major oil generation (0.6 percent), and the data exhibit a broader scatter of values. The present temperature gradient also increases from an average rate of about 2.01 °F/100 feet to 2.44 °F/100 feet in this region. At approximately 11,900 feet, there is a second more pronounced discontinuity in vitrinite reflectance. R_o increases discontinuously from 0.75 percent to 1.0 percent and then to 1.3 percent at 12,200 feet. From 12,200 to 13,980 feet, R_o values range between 1.2 and 1.4 percent. At 13,980 feet, R_o increases to 2.44, which is metagenic grade, and at greater depths, vitrinite reflectances are highly erratic and increase to metamorphic grade. These offsets in the random vitrinite reflectance profile could be related to unconformities. However, owing to the absence of a well defined trend in the R_o values in the lower part of the well, it is inadvisable to apply Dow's method (1977) to compute the amount of stratigraphic section that may have been deleted from the record. It is possible, however, that significant amounts of sediment in the most favorable maturity range are not represented in the stratigraphic section penetrated by this test well.

Carbon preference indices used by the two laboratories differ slightly. That used by Core Laboratories is as follows:

$$\text{CPI} = 1/2 \left[\frac{C_{25} + C_{27} + C_{29} + C_{31} + C_{33}}{C_{26} + C_{28} + C_{30} + C_{32} + C_{34}} + \frac{C_{25} + C_{27} + C_{29} + C_{31} + C_{33}}{C_{24} + C_{26} + C_{28} + C_{30} + C_{32}} \right]$$

and Geochem Laboratories defined it as:

$$\text{CPI} = 1/2 \left[\frac{C_{25} + C_{27} + C_{29} + C_{31}}{C_{26} + C_{28} + C_{30} + C_{32}} + \frac{C_{25} + C_{27} + C_{29} + C_{31}}{C_{24} + C_{26} + C_{28} + C_{30}} \right]$$

The computation used by Core Laboratories includes C₃₃ and C₃₄ while the Geochem Laboratories calculation does not. The amounts of C₃₃ and C₃₄ registered on the gas chromatograms are negligible, and the two sets of CPI values are congruent at equivalent depths.

Initial CPI values from immature C₁₅⁺ extracts in the No. 1 well are around 4.0. Hunt (1979) states that nearshore sediments derived from continental debris in basins off Southern California produce CPI values between 2.5 and 5.1. In contrast, extracted bitumen from an immature source would tend to produce a CPI of 1.0 to 1.2, because marine organisms tend to synthesize carbon chains in a lower molecular weight range. CPI values from the two laboratories agree favorably. They begin at approximately 4.0 at a depth of 2,500 feet. Maximum CPI values occur between 4,500 and 5,000 feet where coal is present in the cuttings and then decrease asymptotically to the bottom of the hole. Below 9,500 feet the CPI values remain nearly constant at 1.1 or 1.2. A

slight scatter of the data occurs in the metamorphic rocks at 14,667 feet which is not as pronounced as that exhibited by the Ro values for the same depth.

Barker (1974), Claypool and Reed (1976), and Espitalié and others (1977), have suggested that T_2 -max, the temperature at which maximum evolution of thermal hydrocarbons occurs during pyrolysis, can be used to characterize the degree of thermal maturation of kerogen. However, these measurements can vary from instrument to instrument, and are dependent upon the rate of heating and also upon the type of kerogen being analyzed. Type III kerogen from a terrestrial source tends to exhibit lower T_2 -max values than would lacustrine or marine types I and II. Geochem Laboratories conducted the pyrolysis. Their interpretive charts imply that the most favorable range of T_2 -max values for oil generation lies between 435° and 460 °C. The T_2 -max values plotted on Figure 37 suggest that the threshold for optimum petroleum generation occurs near 432 °C, about 9,500 feet. At roughly 12,300 feet, T_2 -max values increase sharply to greater than 450 °C and become erratic. At 13,600 feet, T_2 -max has reached 500 °C and from this depth to 14,400 feet values are scattered from 352 to 506 °C.

There seems to be a general agreement among maturity indicators implying that the onset of major oil generation should occur at approximately 9,500 feet and that much of the oil generated would be preserved to at least 12,200 feet. Below 12,600 feet vitrinite reflectances are high but not reliable, T_2 -max values from pyrolysis are erratic and very high in some cases, and TAI values indicate severely

altered to metamorphosed sediments. Although there is no clear sense of accord among maturity indicators at this depth, it is probable that kerogens have reached metagenic grade and may have been metamorphosed below 13,000 feet.

Hydrocarbon Source Potential

Total organic carbon, light- ($C_1 - C_4$) and gasoline-range ($C_5 - C_7$) hydrocarbons, C_{15+} hydrocarbon extract, and pyrolysis data from whole rock samples are displayed in Figure 38. Geochem Laboratories analyzed both cuttings and airspace in the sealed cans of samples for light hydrocarbons. The results of the pairs of analyses were then summed to yield the $C_1 - C_7$ hydrocarbon content. Core Laboratories analyzed cuttings for $C_4 - C_7$ gasoline-range hydrocarbons. The C_4 content of the Core Laboratories analyses in figure 38 was subtracted to make possible the comparison of their gasoline-range hydrocarbon values with those of Geochem Laboratories. Both laboratories also analyzed sidewall cores and conventional cores.

$C_1 - C_4$ content of samples from approximately 1,000 to about 9,000 feet generally exceed 10,000 volumes of gas per million volumes of rock (ppm) at normal atmospheric temperature and pressure, except for the interval between 7,000 and 9,000 feet in which it drops slightly. From 1,000 to 9,000 feet, both $C_2 - C_4$ and $C_5 - C_7$ hydrocarbons increase progressively two orders of magnitude from between 10 and 100 ppm to more than 10,000 ppm. Between 9,500 and 12,500 feet, $C_1 - C_4$ and $C_2 - C_4$ values are approximately 40,000 ppm and then decrease dramatically with further depth. Anomalously high values occur where even trace

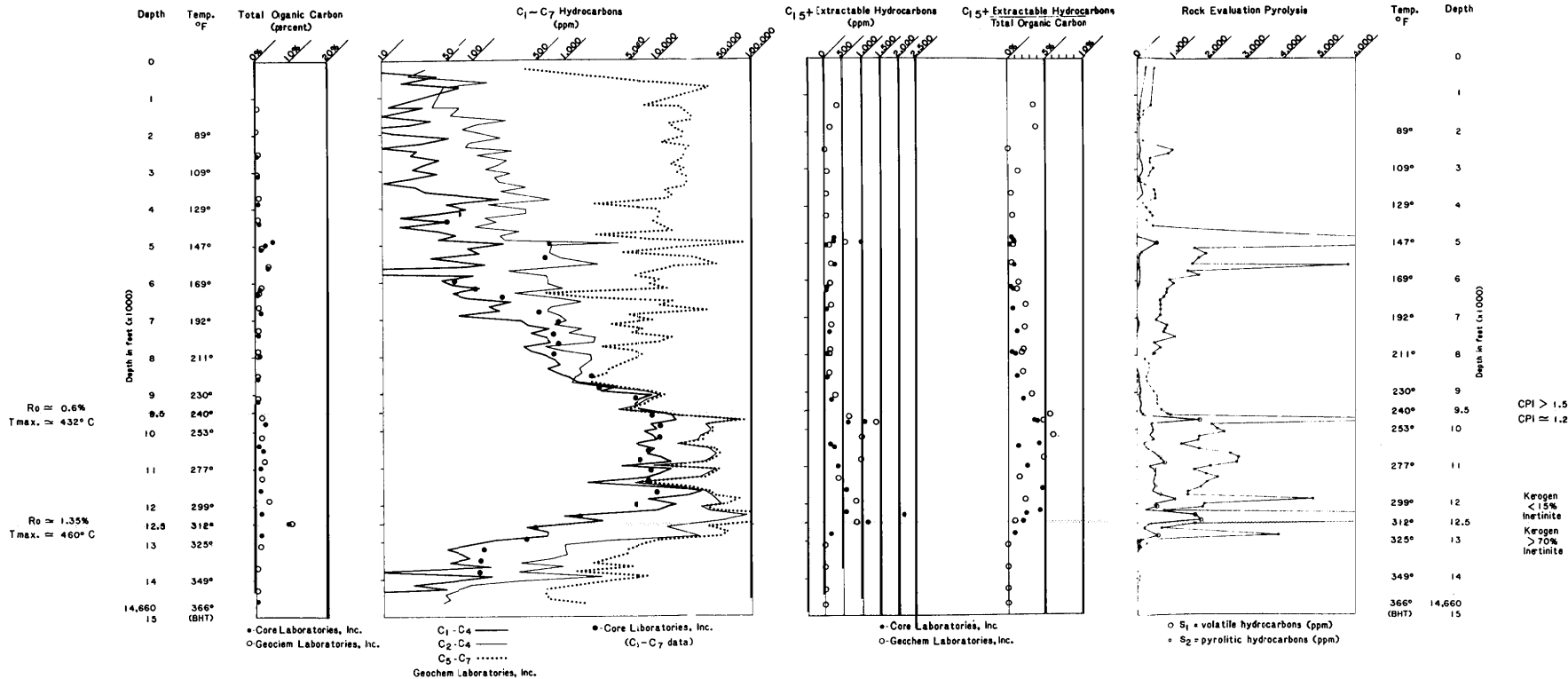

Figure 38.—Organic Richness and Hydrocarbon Potential

amounts of coal are present. C₅ - C₇ values in this interval remain approximately 10,000 ppm and begin to drop sharply at 12,200 feet.

Core Laboratories and Geochem Laboratories used slightly different procedures to obtain C₁₅+ extractable organic matter and heavy hydrocarbons. Core Laboratories performed the soxhlet extractions with chloroform and forced evaporation of the solvent at 40° C. The extracted residue was then separated into saturated, aromatic, and asphaltic fractions by silica gel chromatography. Geochem Laboratories performed the soxhlet extractions with a co-distilled toluene-methanol azeotrope solvent. Asphaltenes were separated from soluble C₁₅+ bitumens with pentane. Adsorption chromatography on a silica gel-alumina column was performed using pentane, toluene and toluene-methanol azeotrope eluants.

Data produced by the two laboratories are in good agreement. Anomalous concentrations of C₁₅+ extractable hydrocarbons occur at about the same depths as maximum values for light- and gasoline-range hydrocarbons in the No. 1 well. Various empirical threshold values have been suggested to define anomalous levels of C₁₅+ extractable hydrocarbons. Bayliss and Smith (1980) regard 200 to 400 ppm on a weight to weight basis as a good anomaly. Hunt (1979) considers 50 to 150 ppm to be adequate, but Phillippi (1957) has placed the threshold level of a good anomaly as high as 500 ppm. Measured C₁₅+ extractable hydrocarbon values from this well in excess of 200 ppm occur from 4,800 to 5,580 feet and from 9,060 to 12,420 feet. Observed C₁₅+ extractable hydrocarbon contents in excess of 500 ppm occur at 4,920 feet, 4,980

feet, and between 9,600 and 12,420 feet. At depths greater than 12,420 feet, the amount of total extractable hydrocarbons decreases very rapidly as inertinite content of the kerogen increases and TOC decreases.

Hunt (1979) cites a study of Mesozoic-Cenozoic rocks in the western Ciscaspian region (Larskaya and Zhabrev, 1964), indicating that the "bitumen coefficient," the ratio between chloroform soluble carbon and total organic carbon, is related to temperature. These investigations concluded that in the area where the rocks they studied contained predominantly coaly particles, the "bitumen coefficient" was very small and changed very little with increasing temperature. Where amorphous matter occurred, the "bitumen coefficient" was high and increased rapidly with temperature. Their studies imply that bitumen yields of fine-grained rocks in sedimentary basins are related to kerogen type.

The extractable heavy hydrocarbon-total organic carbon ratio $\frac{C_{15+} \text{ HC's}}{\text{TOC}}$ in Figure 38 is analogous to the "bitumen coefficient" discussed by Hunt.

These values are relatively low, generally less than 2 or 3 percent, and change little until the interval between 9,600 and 12,420 feet. Maximum $\frac{C_{15+} \text{ HC's}}{\text{TOC}}$ values of 5.6 and 6.0 percent occur at depths of 9,600 and 10,140 feet respectively and these depths correspond to a present day temperature range of 240° to 255°F. Mean "bitumen coefficient" values for oil-bearing rocks of 5 to 6 percent were

observed by Larskaya and Zhabrev (1964) at about 230°F. Since C₁₅₊ extractable hydrocarbons do not contain the nonhydrocarbon components that are normally present in bitumens, it is assumed that "bitumen coefficients" for the No. 1 well would actually be somewhat greater than the heavy hydrocarbon-organic carbon ratio in Figure 38.

The TOC, $\frac{C_{15+} \text{ HC's}}{\text{TOC}}$, and gross lithologic descriptions of cuttings

for samples with anomalous C₁₅₊ extractable hydrocarbon contents mentioned above are presented in Table 4. The samples at 4,920 and 4,980 feet are suspect because of the presence of casing cement. The contrast in TOC values measured by the two laboratories at 4,980 feet probably occurred because each laboratory had separate and distinct coal fragments in the samples that it analyzed. Both measurements are far too high to have been produced by kerogen alone. The difference in the C₁₅₊ extractable hydrocarbon measurements at 4,920 feet are most likely the result of the difference in the relative efficiencies of the two extraction techniques. TOC values are well above 2 percent,

$\frac{C_{15+} \text{ HC's}}{\text{TOC}}$ values are less than 1 percent, and significant amounts of

coal are recorded in the lithologic description. In the samples from 9,600 and 10,140 feet, TOC is greater than 1 percent but not much greater than 2 percent. The $\frac{C_{15+} \text{ HC's}}{\text{TOC}}$ is high, and no

coal appears in the lithologic descriptions.

Table 4. Selected Geochemical Data From Samples With Anomolously Heavy Hydrocarbon Contents

Depth	Total Organic Carbon (%)		C ₁₅ + Extractable Hydrocarbons (PPM)		C ₁₅ + Extractable Hydrocarbons (%)		Gross Lithologic Description
	Core Lab	Geochem Lab	Core Lab	Geochem Lab	Core Lab	Geochem Lab	
4,920	2.85/2.87	no data	210	570	0.7	no data	Core Lab: 90% mdst; m-d brn, slt mica, slt calc, sft-frm, assoc w/cly; m-d brn, slt mica, slt calc, 10% sh-coal; dk brn-blk, v fiss, sft, pres-pyr Geochem Lab: 60% mudstone, very slightly calcareous, chunky, soft, pale yellowish brown; 25% shale, non-calcareous, platy, fissle, soft, dk gray; 15% casing cement
4,980	11.04	52.17	967	no data	0.9	no data	Core Lab: 80% sh-coal; v carb, fiss mica; 20% mdst; m-d brn spec, slt mica, sft-frm, w/cly; m-d brn, slt calc Geochem Lab: 80% coal bituminous 20% casing cement
9,600	1.15	1.15	no data	638	no data	5.6	Core Lab: Sltst; gy, brn-gy, mica, mstly plty, occ mass, frm, spec, n calc, Pres-pyr; ss; wh, gy, gn, spec, calc, f gr Geochem Lab: 100% shale, noncalcareous, splintery, chunky, mod. soft medium gray to dk gray, traces of limestone
10,140	1.54	1.65	no data	994	no data	6.0	Core Lab: Sh; brn-gy dk gy, gy, mica, mstly plty, frm, occ slty, occ bladed, occ wxy, occ blk carb lam Geochem Lab: 100% shale, noncalcareous, slightly carbonaceous, micaceous, occasionally pyritized, chalky, flaky, moderately soft, med. gray to brownish black, trace of mudstone, ss and pyrite

It appears from these data that heavy hydrocarbon extracts at depths greater than 9,500 feet may be derived from both moderately mature, organically rich clastic sediments and coal. However, relatively shallow hydrocarbon anomalies, where thermal maturity is low and TOC is approximately 3 percent, such as those at 4,920 and 4,980 feet, are related to lithologies rich in coal.

Geochem Laboratories produced chromatograms directly after extraction of C₁₅+ bitumens and after filtering C₁₅+ extract through a molecular sieve. Core Laboratories made chromatograms of C₁₀+ saturated hydrocarbons. Extractable organic matter was dissolved in chloroform and iso-octane used to remove the chloroform without loss of the low boiling point fraction of the saturated hydrocarbons. The concentrate was then separated by silica gel column chromatography with a hexane eluant. The CPI values computed by Core Lab were derived from this data.

The four chromatograms shown in Figure 39 are taken from Geochem Laboratories data. The disappearance of the bimodality of the n-alkane distribution, the decrease in the CPI, and the shift toward lower-molecular-weight range n-paraffins all indicate a progressive increase in maturity with depth and suggest that if oil is produced from these kerogens, it will probably have a paraffinic character.

Two chromatograms from Core Laboratories representative of C₁₀+ saturated extractable hydrocarbon content at 12,180 and 12,240 feet are shown in Figure 40. The dramatic reduction in the content of the higher molecular weight paraffin and naphthene molecules in the bitumen probably reflects a combination of the sudden increase in the inertinite content

Standard

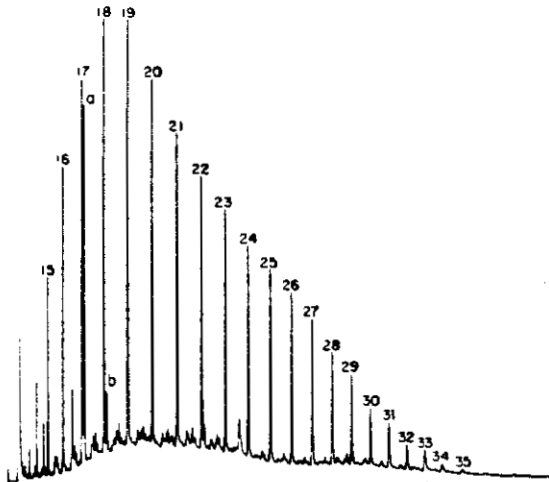

Number Denotes $n-C_n$ Paraffin
a= $ip-C_{19}$ -Isoprenoid Pristane
b= $ip-C_{20}$ -Isoprenoid Phytane

Sample Number 108

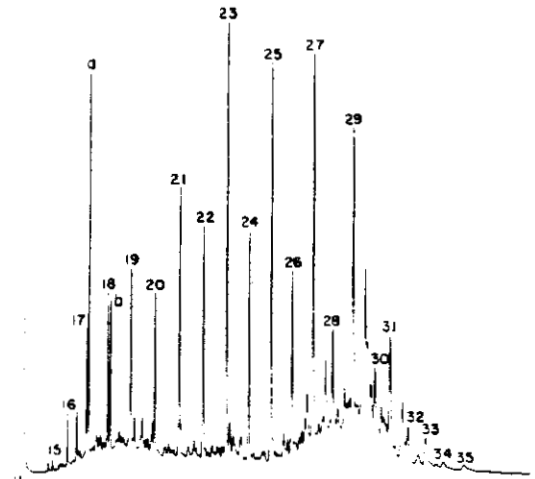

Depth 6,660 Ft
 $CPI_b = 2.90$

Sample Number 188

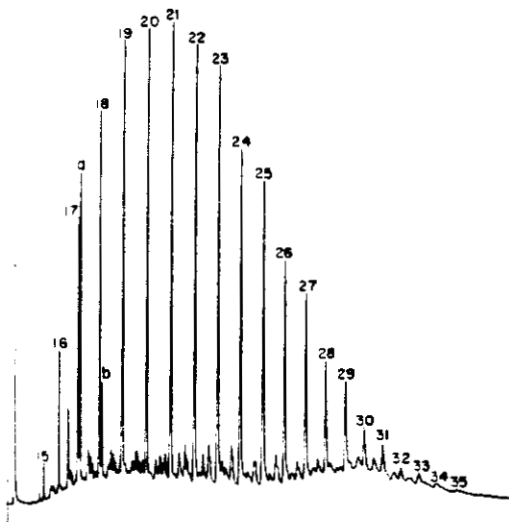

Depth 11,280 Ft
 $CPI_b = 1.22$

Sample Number 238

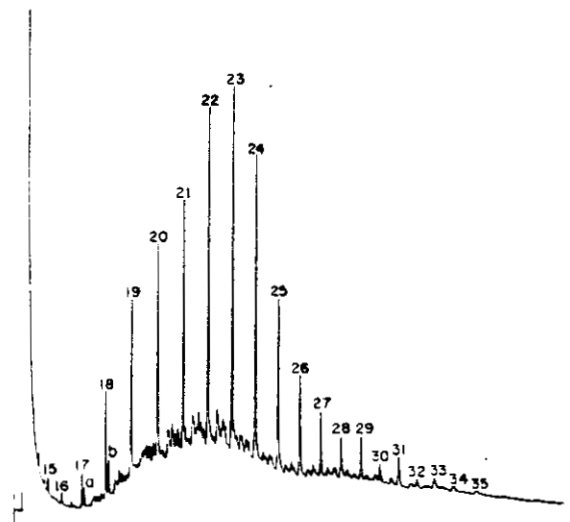

Depth 14,280 Ft
 $CPI_b = 1.27$

Figure 39.--Representative C_{15+} Gas Chromatograms
[Geochem Laboratories, Inc.]

C₁₀+ Saturated Hydrocarbon Fraction

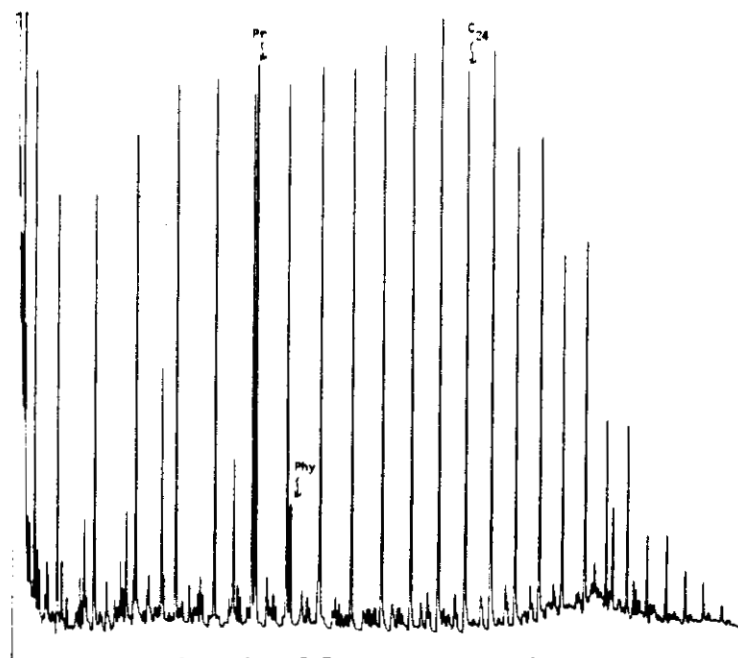

Depth 12,180 feet CPI=1.24

C₁₀+ Saturated Hydrocarbon Fraction

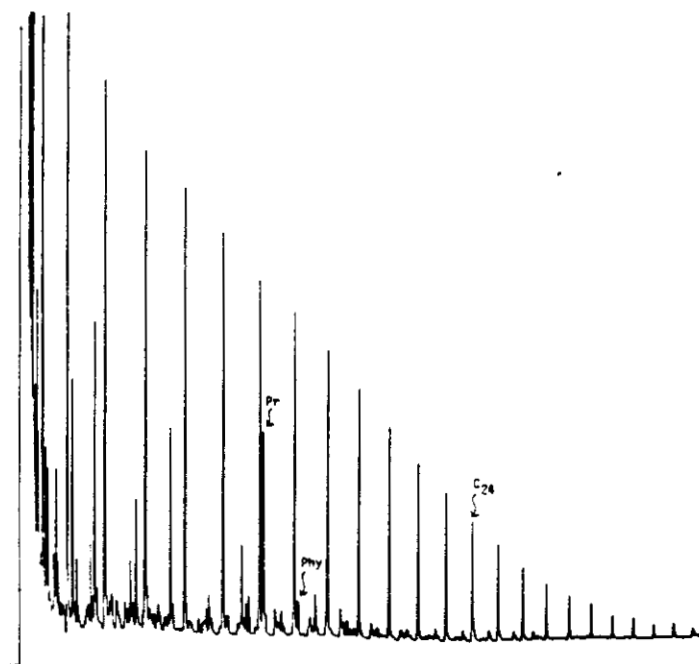

Depth 12,240 feet CPI=1.11

**Figure 40.--Representative C₁₀+ Gas Chromatograms
[Core Laboratories, Inc.]**

of the kerogen at the expense of vitrinite and exinitic kerogens, and a discontinuous increase in thermal maturity of the kerogen at this depth. The "molecular sieved" chromatograms of Geochem Laboratories exhibit a similar trend.

The carbon isotope ratios from both saturated and aromatic heavy hydrocarbon extracts were computed by Geochem Laboratories from samples collected between 1,260 and 14,280 feet using the Peedee belemnite standard and the following formula.

$$\delta^{13}\text{C} = \frac{(^{13}\text{C}/^{12}\text{C}) \text{ sample}}{(^{13}\text{C}/^{12}\text{C}) \text{ standard}} - 1 \times 1000$$

The results are given in Table 5.

Table 5. Carbon Isotope Ratios ($\delta^{13}\text{C}$) in parts per thousand from heavy hydrocarbon extracts.

Depth below Kelly bushing	Saturated Extracts (per mil)	Aromatic Extracts (per mil)	Difference (per mil)
1,260	-28.2	-26.8	1.8
1,860	-27.7	-27.5	0.2
2,460	-27.6	-27.0	0.6
3,060	-27.9	-27.1	0.8
3,660	-28.1	-27.3	0.8
4,260	-28.6	-27.7	0.9
4,920	-28.1	-27.2	0.9
5,520	-28.1	-27.0	1.1
6,060	-28.1	-27.5	0.6
6,660	-28.5	-27.4	1.1
7,260	-28.0	-26.7	0.3
7,860	-28.0	-26.8	1.2
8,460	-28.0	-27.4	0.6
9,060	-28.5	-26.8	2.0
9,600	-28.8	-26.8	2.0
10,140	-29.2	-27.2	2.0
10,740	-28.6	-26.5	2.1
11,280	-27.8	-26.2	1.6
11,880	-28.4	-26.1	2.3
12,420	-24.7	-24.6	0.1
13,080	-27.6	Insufficient sample	
13,680	-27.7	Insufficient sample	
14,280	-27.7	Insufficient sample	

Fuex (1977) suggests that the carbon isotopic composition of a hydrocarbon depends upon the $\delta^{13}\text{C}$ content of the source material, any fractionation attendant upon its formation, and any fractionation subsequent to its formation. However, the $\delta^{13}\text{C}$ values from high-molecular-weight hydrocarbon components of oil and rock samples are relatively free from both types of fractionations. Therefore, carbon isotope ratios from heavy hydrocarbon extracts can be useful as indicators of the source of the materials that produced the hydrocarbons. However, Fuex warns that the presence of non-indigenous oils could be very misleading.

Samples of twenty-two saturated hydrocarbons have a mean $\delta^{13}\text{C}$ ratio of -28.1 ± 0.42 per mil. Samples of nineteen aromatic hydrocarbons have a mean value of -27.0 ± 0.41 per mil. Samples acquired from below 12,420 feet did not contain sufficient aromatic components to permit isotopic analysis. Silverman (1964) and Silverman and Epstein (1958) state that these isotopically light bitumens are characteristic of kerogens derived from a terrestrial source.

One sample collected at 12,420 feet was not included in the populations averaged above. The $\delta^{13}\text{C}$ values for saturate and aromatic hydrocarbons were -24.7 per mil and -24.6 per mil respectively. Park and Epstein (1960) say that these heavier carbon isotope ratios are more characteristic of a marine origin. Neither geochemistry nor paleobathymetry conclusively determined the probable source of the sediments at 12,420 feet but the Van Krevelen diagrams (figs. 35 and 36) indicate a type III kerogen, with the predominant kerogen macerals being

herbaceous material and inertinite. The H/C ratio is low, and coal is present in the cuttings. The contradictory nature of this $\delta^{13}\text{C}$ value may indicate that the bituminous extracts sampled at this depth were not produced by indigenous kerogen.

Rock-eval pyrolysis is performed by heating whole rock samples in an inert atmosphere at a predetermined rate. Free or adsorbed hydrocarbons already present in the rock are volatilized first at a moderate temperature. As the temperature increases, pyrolysis of kerogen generates hydrocarbons and hydrocarbon-like compounds. Finally oxygen-bearing volatiles such as carbon dioxide and water are evolved. Relative amounts of the hydrocarbons are measured by a flame ionization detector and quantities of oxygen-bearing compounds by a thermal conductivity detector. The three parameters are frequently reported in weight to weight ratios of evolved gas to rock sample and are abbreviated by the symbols S_1 , S_2 , and S_3 respectively.

Studies by Claypool and Reed (1976) indicate that the S_1 peak is directly proportional to the concentration of extractable C_{15}^+ hydrocarbons and the S_2 peak is approximately proportional to the organic carbon content of the rock. The sum $S_1 + S_2$, is termed the genetic potential by Tissot and Welte (1978) because it accounts for both type and abundance of organic matter. They suggest the following threshold values for evaluating the oil and gas potential of source rock.

$S_1 + S_2$ (ppm)	Source Rock Potential
Less than 2,000	No oil. Some gas.
2,000 to 6,000	Moderate source rock.
Greater than 6,000	Good source rock.

The temperature T_2 -max, already referred to in the maturation section of this report, is the temperature at which the maximum evolution of pyrolytic hydrocarbons (the S_2 peak) occurs. The hydrogen index and oxygen index are defined as S_2 /organic carbon and S_3 /organic carbon respectively in milligrams of gas per gram of organic carbon. These indices are independent of the abundance of organic matter and are closely related to the atomic H/C and O/C ratios (Tissot and Welte, 1978).

S_1 and $S_1 + S_2$ data are displayed in Figure 38. $S_1 + S_2$ values in excess of 1000 stand out between 4,980 and 6,060 feet and between 9,720 and 12,540 feet. $S_1 + S_2$ values in excess of 6,000 ppm occur at 4,980, 9,720, 12,300, 12,420 feet in the cuttings and at 9,201 feet in a sidewall core and 9,758 feet in a conventional core. Again, the very high values tend to occur where coal is present in the cuttings.

Summary and Conclusions

Geochemical data from the No. 1 well indicate a predominantly type III humic kerogen commonly found in what Demaison (1981) has termed a "type C" organic facies. This facies is typically the product of a mildly oxic depositional environment and may contain interfingering marine and nonmarine sediments, slope and rise deposits, and exinite-rich coals. It is characterized geochemically at an Ro of approximately 0.5 percent in the following manner,

H/C:	0.8 to 1.0
Hydrogen Index (HI):	25 to 125 <u>mg HC's</u> g TOC
Oxygen Index (OI):	50 to 200 <u>mg CO₂</u> g TOC

Measurements of these parameters at a depth of 9,600 feet where Ro is 0.48 percent produced the following results;

H/C:	0.827 to 0.939
HI:	64 <u>mg HC's</u> g TOC
OI:	105 <u>mg CO₂</u> g TOC

Hydrocarbons formed in a type C organic facies tend to be gas prone, sometimes with condensate. Visual identification of kerogen and $\delta^{13}\text{C}$ values derived from heavy hydrocarbon extracts support the hypothesis that much of the organic matter is derived from terrestrial sources.

No thick coal units are present in the No. 1 well, but there is a correlation between coal in the samples and the anomalously high geochemical values in this well. Two organically rich zones are present from 4,400 to 6,000 feet and from 9,500 to 12,540 feet. Their potential as source rocks are summarized in Table 6.

Although the organic carbon content between 4,400 and 6,000 feet is high, the vitrinite reflectance and bitumen extract imply thermal immaturity. The light hydrocarbon fractions are predominantly methane; only two samples exhibit extractable C_{15+} hydrocarbon contents in excess of 500 ppm, and the amount of C_{15+} hydrocarbon present in the two samples is not extraordinary given the organic carbon content of the pair. Finally, coal is present in the sample cuttings and comprised 80 percent of one of the samples. The sediments in the interval from 4,980 to 6,000 feet exhibit high $S_1 + S_2$ values, which suggests that this zone could produce hydrocarbons in a deeper thermally mature part of the basin. Alternatively, the coal bearing lithology could generate hydrocarbons at the depth at which it presently occurs if sufficient amounts of resinite and other sapropelic macerals were present. Powell and McKirdy (1975) have pointed out that paraffinic and paraffinic-napthenic crude oils from Australia are thought to have been

DEPTH (ft.)	LEVEL OF MATURITY	T.O.C. > 1.0%	LIGHT HYDROCARBONS	EXTRACTABLE C ₁₅ ⁺ HYDROCARBONS > 500 ppm	S ₁ + S ₂ > 1,000 ppm (PYROLYSIS)
4,400	T-max. \approx 420°C CPI \approx 4	4,400 ft. to 6,060 ft.	(C ₁ - C ₄) \gg (C ₂ - C ₄)	4920 ft. and 4980 ft. C ₁₅ ⁺ /TOC < 1%	4,980 ft. to 6,060 ft. (S ₁ + S ₂) > 6000 ppm at 4,980 ft.
6,000	T-max. \approx 431°C CPI \approx 3				
9,500	T-max. \approx 432°C CPI \approx 1.4	9,500 ft. to 12,800 ft.	9,500' to 12,200' (C ₁ - C ₄) (C ₂ - C ₄)	9,600 ft. to 12,420 ft. C ₁₅ ⁺ /TOC > 1%	9,720 ft. to 12,540 ft. (S ₁ + S ₂) > 6,000 ppm 9,201 ft. 9,720 ft. 9,757 ft.
12,540	T-max. \approx 467°C CPI \approx 1.1+				12,300 ft. 12,420 ft.

TABLE 6. Summary of Hydrocarbon Potential Indicators in Organically Rich Horizons

derived from the leaf, pollen, and spore cuticles of higher plants. Snowden and Powell (1982) describe naphthenic oils and condensate in the Tertiary of the Beaufort-MacKenzie basin that they suggest have been generated from terrestrially derived organic matter in source rocks juxtaposed with the reservoir at vitrinite reflectance levels of only 0.4 to 0.6 percent. Snowden (1980) has suggested that resinite existing in coal fragments within the sediments is the source of these hydrocarbons.

Sediments that have been buried to depths in excess of 9,500 feet are sufficiently mature and rich in organic carbon to produce hydrocarbons. The base of the oil generation and preservation zone is approximately 12,545 feet where the rocks begin to assume a metamorphic character. The concentrations of light- and gasoline-range hydrocarbons, C₁₅+ extractable hydrocarbons, and pyrolysis data are all favorable for oil generation though no free hydrocarbons were found during drilling operations. At depths greater than 13,000 feet there is insufficient organic carbon present to serve as a likely source for commercial quantities of hydrocarbons.

ENVIRONMENTAL CONSIDERATIONS

By Paul Lowry

ARCO Oil and Gas Company, as operator for itself and other participants, submitted a letter dated August 3, 1979, for the proposed drilling of a Deep Stratigraphic Test well in the Norton Sound area of the Alaska Outer Continental Shelf. Documents in support of this proposal included a Drilling Plan, an Environmental Analysis, an Oilspill Contingency Plan, and Coastal Zone Consistency Certification. On the basis of preliminary information on the proposed locations, a site-specific biological survey, a geohazards survey, and a geotechnical survey at the primary and alternate sites, to detail environmental conditions were required before approval of the Geological and Geophysical (G&G) Permit application for the Deep Stratigraphic Test well. The applicant followed 30 CFR Part 251 in submission of the G&G Permit for this well.

A Deep Stratigraphic Test well is intended to acquire geological and engineering data to determine the potential for hydrocarbon accumulation within a proposed sale area. It is commonly drilled off structure, and it is not intended that any hydrocarbon accumulations be found. Although the revised regulations do not forbid drilling on structure, the Norton Sound No. 1 well was drilled off structure. The information gathered from this test well was used to further evaluate the hydrocarbon potential of OCS

Lease Sale No. 57 (Norton Basin) held on March 15, 1983.

As part of the permit application review process, an Environmental Assessment (EA) under the National Environmental Policy Act (NEPA) directive was prepared. An EA serves as a decision-making document to determine if the proposed action is or is not a major Federal action significantly affecting the quality of the human environment in the sense of NEPA, Section 102(2)(C). An EA addresses and includes the following: description of the proposed action, description of the affected environment, environmental consequences, alternatives to the proposed action, unavoidable adverse environmental effects, and controversial issues.

On the basis of existing data and regulations in effect at the time the proposal was being reviewed, the following specific environmental aspects were considered by MMS before the drilling plan was approved.

Geological

A site-specific shallow drilling hazards survey (Tetra Tech Inc., 1979a) and a geotechnical survey (Woodward-Clyde, 1979), required by MMS, showed the seafloor at the proposed sites to be nearly flat and relatively featureless. The sites lie within the Norton Basin, a geologic depression filled in with predominantly Cenozoic sedimentary rocks. The bottom sediment consists of very dense, sandy silt. The basin structure is dominated by west-northwest trending normal faults that often occur as grabens. Many of the faults are growth faults that exhibit increased

displacement on the down-thrown side. Few faults in the Norton Sound area displace the seafloor; sea-floor fault scarps have been reported in the periphery of the basin, but there are none within the vicinity of the subject well.

Potential hazards:

1. Ice-gouging of bottom sediments by floating pack ice has been reported in Norton Sound. The predominant movement of the pack ice is to the southwest. This movement creates a zone of convergence seaward of the Yukon Delta, causing pressure ridges to form where the drifting pack ice shears past the stationary shorefast ice. Both pressure-ridge raking and solitary gouges occur, and they are most common between the 33- to 65-foot isobaths off the Yukon Delta. No gouges were reported in the immediate vicinity of the well.
2. An area of intense current scour has been reported seaward of the Yukon Delta. These scour zones are associated with ice gouges and increased bottom steepness. Actively migrating sand waves have been observed off Port Clarence near the Bering Straits. Neither scour zones nor sand waves have been reported in the vicinity of the No. 1 well location.
3. Seismicity in the Norton Sound region is generally low to moderate. The largest recorded earthquake reached a magnitude of 6.5 Richter and was located on the Seward Peninsula about 18.4

miles inland from Norton Sound. Most recorded earthquakes in the area range from magnitude 1 to 4.5 Richter.

4. Numerous biogenic gas craters occur in eastern Norton Sound; a thermogenic gas seep has been reported 25 miles south of Nome. No gas anomalies were identified at the well site.

No undue restraints were imposed on this Deep Stratigraphic Test well program because of geologic hazards, and no operational problems developed.

Meteorological and Oceanographic Data

Most of the Bering Sea lies in subarctic latitudes; therefore, a cyclonic atmospheric circulation predominates in this region. Cloudy skies, moderately heavy precipitation, and strong surface winds characterize the marine weather. Storms are more frequent in the fall than in the summer.

There are two dominant current patterns in the Norton Sound area; northward flowing currents that pass east of St. Lawrence Island, and the counterclockwise circulation system within Norton Sound. Wave heights greater than 8 feet are common less than 10 percent of the time in August and September, and less than 20 percent of the time in October. At Nome, the mean dates of sea-ice breakup and freezeup are May 29 and November 12, respectively. Superstructure icing is possible in June and is probable in October.

Sea ice conditions in Norton Sound vary from site to site and ice movement is caused by combination of geography and prevailing northeast winter winds. The prevailing northeast winds result in an almost continuous east-northeast to west-southwest evacuation of ice from the Sound throughout the winter. Except for the shore-fast ice, the ice in this area is entirely replaced by this process several times during a season. First-year ice usually moves out of the area by the time it is about 18 inches thick. The site is characterized by relatively thin, weak ice in constant motion with extensive rafting.

Pack ice generally begins to form in Norton Sound in mid- to late October. Some areas in and around the Sound are completely ice covered by mid-November. After mid-December, pack ice generally completely covers the Sound.

By mid-March the ice pack at the head of the Sound begins to thin, but does not show appreciable melting until mid-May. By mid-June the Sound is completely ice free. The No. 1 well was drilled during an open-water season.

Because limited meteorological and oceanographic data were available, the MMS issued the Guidelines for Collection of Meteorological, Oceanographic, and Performance Data (January 21, 1982) and required the operator to collect meteorological information to aid in future operations within Norton Sound. During setup and operation, climatic and sea state conditions were monitored to ensure that local conditions did not exceed rig tolerances or jeopardize human safety. Winds, barometric pressure, air and

water temperatures, waves, currents, and ice conditions were monitored. All environmental data collected during the drilling of this well are available to the public.

Biological Survey

Biological Survey Results

A site-specific marine biological survey was designed by MMS in concert with other Federal and State agencies to provide biological data at the proposed Deep Stratigraphic Test sites. Through the use of underwater video and photographic documentation, plankton tows, infaunal sampling, and trawling; Tetra Tech Inc., (1979b) determined the relative abundance and types of organisms present in various habitats. These studies were conducted during June and July 1979 to determine biological resources at the proposed drill sites. The results are summarized as follows:

1. Underwater television and bathymetry records indicated that the seafloor at both sites is flat. Sediments in both areas consist of sand (60 percent), silt (35 percent), shell debris and clay (less than 5 percent).
2. The zooplankton in both areas was dominated numerically by small jellyfish and copepods. Five fish larvae were collected at the primary site and 17 at the alternate site; of the total, 11 were pleuronectids (probably Limanda sp.) and 9 were gadid larvae.

3. Approximately 900 fish eggs were collected at the two sites; over half had not developed sufficiently to be identified. Approximately 40 percent were pleuronectid eggs, probably Limanda sp.
4. About 1,000 larval malacostracans were collected, one-fourth of which were not identifiable. About half were larvae of the hermit crab family (Paruridae) and 15 percent were shrimp larvae. No larvae of king or Tanner crabs were collected.
5. The infauna at the primary site averaged 38 taxa and 230 individuals per 0.1 m²/grab. Annelids and arthropods accounted for 85 percent of all organisms collected. The three most abundant organisms were the amphipod, Protomedeia sp., and the polychaetes, Myriochele oculata and Haploscoloplos elongatus. At the alternate site, the grab samples averaged 29 taxa and 346 individuals. Annelids alone comprised 80 percent of all organisms collected, and the three most abundant organisms were the polychaetes Tharyx parvus, Haploscoloplos elongatus, and Mediomastus californiensis.
6. Demersal trawls collected approximately 3 pounds of fish each 30-minute haul. Overall, Pacific tomcod (Microgadus proximus) and Yellowfin sole (Limanda aspera) were most abundant. The invertebrate catch in both areas was dominated numerically by echinoderms.

On the basis of biological surveys conducted by Tetra Tech, Inc., neither site supported unique habitats or species of special interest that required rejection or modification of the test well program. The Regional

Supervisor, Offshore Field Operations, concluded that normal drilling operations at either of the two sites would not adversely affect the environment.

Marine Mammals/Endangered Species

Marine mammal distribution in the northern Bering Sea and Norton Sound is strongly influenced by the presence of sea ice. Seasonal distributions of several species, particularly bowhead and beluga whales, walrus, and ringed, bearded, and spotted seals are closely associated with the advancing and retreating edge of the pack ice. These species winter in the Norton Sound-north Bering Sea region at the southern limit of the pack ice and generally follow its retreat northward during summer. However, not all individuals move north to the Chukchi and Beaufort Seas at that time. A few walrus, spotted and bearded seals, and beluga and killer whales may still be encountered in Norton Sound during summer.

The only endangered mammal species listed for the Norton Sound area were the gray, bowhead, fin, and humpback whales. The endangered peregrine falcon occurs along the coast in the Norton Sound area.

A formal consultation was requested from U.S. Fish and Wildlife Service (USF&WS) and National Marine Fisheries Service (NMFS) regarding endangered species for the Norton Sound area in a letter dated August 7, 1979. NMFS concluded that whales, which utilize the proposed lease area in general, primarily occur west of a line between Nome and the Yukon River Delta (166°W. longitude). Because of the limited area and duration of the

drilling program, it was concluded that the activity would not jeopardize gray, bowhead, fin, or humpback whales or result in the destruction or adverse modification of critical habitat. The well site was outside the normal range for the peregrine falcon.

Fisheries

The marine fishery of Norton Sound is not as productive as that in other portions of the Bering Sea; however, there is a limited commercial utilization of local shellfish and demersal fish. Most abundant demersal fish include cod, flatfish, sculpins, herring, and smelt. Shrimp, king and Tanner crab, and clams dominate the shellfish resources.

Birds

The Norton Sound avifauna is dominated by the summer waterfowl and shorebird presence at the Yukon Delta. This area is recognized as one of the most productive nesting areas in Alaska. Estimates of summer populations include 3 million waterfowl and over 100 million shorebirds; 170 different species have been recorded. Coastal salt marshes, which are the key to this area's productivity, provide nesting habitat for birds such as black brant; emperor, cackling, and white-fronted geese; common, spectacled, and Stellar's eiders; whistling swans; and numerous ducks and shorebirds. These birds have a strong affinity for coastal habitats and do not occur more than 2 to 3 miles offshore, except during migrations.

Norton Sound also supports several marine bird rookeries, although the number of colonies and their individual sizes (number of birds) do not compare with those in other Bering Sea regions. Murres, kittiwakes, cormorants, and puffins are most common.

Cultural Resources

Cultural resource surveys may be required in order to assure that no disturbance of archeological or cultural resources on the seafloor. After consultation with the resource agencies, MMS determined that such surveys would not be required for the Norton Sound Deep Stratigraphic Test well sites as they were located in low-probability areas for cultural resources. If the TV transects and side-scan sonar taken in conjunction with the biological survey had indicated unexplained anomalies, a review by a qualified marine archeologist would have been required. No such anomalies were detected. No cultural resources were identified during drilling operations.

Discharges into the Marine Environment

Some liquid wastes, including oil from the oil/water separator, were transported from the drilling vessel by supply boats and disposed of in approved onshore locations. Solid wastes were compacted and similarly transported to an approved onshore disposal site. Liquid wastes, including treated sewage, gray water, and some drilling by-products, were discharged on site into marine waters in accordance with regulations set forth by the U.S. Environmental Protection Agency (EPA).

The applicant disposed of drill cuttings and waste drilling mud into the ocean in compliance with existing orders. Past studies on the fate and effects of routine discharges from offshore oil and gas activities into the marine environment and the known dispersion rates of such discharges, show that such operations do not significantly affect on the environment. No oil-based drilling mud was used. Bentonite is a continuous additive to the drilling mud, whereas barite is added as necessary for increasing mud weight. Bentonite and barite are insoluble, nontoxic, and inert. Other additives are used in minor concentrations, and most are used only under special conditions. These other additives are either nontoxic or would chemically neutralize in the mud or upon contact with sea water (i.e., caustic soda). Excess cement entered and was dispersed into the ocean when the shallow casing strings were set.

Contingency Plan for Oilspills

Plans for preventing, reporting, and cleaning up oilspills were addressed in the Oilspill Contingency Plan (OSCP) which was a part of the drilling plan. The OSCP listed the equipment and material available to the permittee and described the capabilities of such equipment under different sea and weather conditions. The plan also included a discussion of logistical support programs for contingency operations. The probability of encountering hydrocarbons that could cause a blowout at any depth was minimized by locating the well off-structure. The operator drilled the well according to the OCS Orders and used standard well-control equipment and procedures. The casing and cementing programs and subsequent abandonment

requirements (as outlined in OCS Order No. 3) were designed to prevent leakage or contamination of fluids within a permeable zone.

Upon completion of the well, the site was cleared of all pipe and other material on or above the ocean floor.

As part of the EA process, the proposed program was submitted to the appropriate Federal and State agencies, as well as interested parties, for comments. Responses were included as part of the EA. On the basis of EA No. AK-80-1, it was determined, on June 6, 1980, that ARCO's proposed action constituted a finding of no significant impact (FONSI), and that an Environmental Impact Statement was not required. A Notice was issued to that effect. MMS consequently issued a letter to ARCO, dated June 13, 1980, approving their proposed action. The EA and the FONSI documents are in the public file in the office of the Regional Supervisor, Offshore Field Operations, 800 A Street, Anchorage, Alaska, 99501.

SUMMARY AND CONCLUSIONS

Ronald F. Turner

Prior to the completion of the Norton Sound Deep Stratigraphic Test well program, very little was known about the petroleum potential of this OCS frontier area. The most widely accepted basin evolution model was the comprehensive analysis of Fisher and others (1982). Since the completion of the second and final test well, however, the number of models has apparently increased to near that of the number of participants. With the public release of these data it is almost certain that the number will increase again. Basin evolution models based on subsurface geological, geophysical, and geochemical data are doubly interpretive owing to the very nature of the data. This interpretation is no exception. It is, however, the first published interpretation made with the benefit of well data. Although time constraints imposed by statutory data release dates have, to some extent, limited various aspects of this ongoing investigation, it is substantially complete. Preliminary analysis of the data from the two wells suggests a basin evolution that differs from the predicted models in several aspects of depositional and subsidence history. In general, the basin fill is younger and far more marine than had been anticipated, and the tectono-eustatic history of the basin is more complex.

The sedimentary basin fill appears to be younger than previous estimates. The presence of Cretaceous sedimentary rocks and coal along the eastern shore of Norton Sound (Patton, 1973) led Fisher and others (1982) to postulate that

the Norton Basin might contain sedimentary rocks as old as Late Cretaceous. However, the middle to late Eocene strata present in the No. 2 well (10,160-12,700 feet) are the oldest sediments for which there is a firm age. This definite Eocene section is underlain by a 1760-foot-thick sequence of interbedded sandstone, siltstone, mudstone, and coal deposited under fluvial and paludal conditions. Eocene fungal palynomorphs were recovered from sidewall cores taken in this section but not from conventional cores. The preservational state of these palynomorphs matched that of in situ elements of the sparse and poorly preserved spore-pollen assemblage. Because of the somewhat equivocal nature of the evidence, this section, and a much thinner correlative section in the No. 1 well (12,235-12,545 feet), was assigned an age of Eocene or older. In both Norton Sound wells these strata unconformably overlie much older metamorphic basement rocks. On the basis of the present data it appears likely that they represent the oldest sedimentary rocks in the basin and are no older than Paleocene, probably younger.

Another less direct line of evidence also supports an early Tertiary age for these sediments. The metamorphic terranes of the Seward Peninsula are the source of much of the sediment in the Norton basin, particularly the St. Lawrence subbasin. A potassium-argon date from a muscovite concentrate from one of the lowermost sandstones in the No. 1 well (12,398 feet, possible Eocene or older section) yielded an age of approximately 146 m.y. This date represents the Late Jurassic to Early Cretaceous metamorphism of the source terrane and is in agreement with potassium-argon ages obtained from white micas from blueschist facies metamorphic rocks from the Seward Peninsula (A. Till, personal communication). Isolated glaucophane-bearing rocks have long been known from

the Seward Peninsula (Smith, 1910; Sainsbury and others, 1970), but more recently Forbes and others (1981), and Till (1982) described an extensive high-temperature blueschist facies terrane there. These rocks are thought to have formed at 8-10 kb pressure at crustal depths of at least 24 km (A. Till, personal communication). In the Late Cretaceous (68-69 m.y., K-Ar date) these rocks were intruded by epizonal granite stocks (the "tin granites") at depths of perhaps 9 km (Hudson, 1979). The overall thickness of the blueschist rocks cannot be ascertained, nor can the amount of section removed at or before the time of granite emplacement. Even so, it seems unlikely that micas that recrystallized at blueschist facies depths in the Late Jurassic-Early Cretaceous, then intruded in the Late Cretaceous while still at great depth, would be available as sedimentary basin fill in the Late Cretaceous. In fact, it appears that the basal unconformity and the onset of basement rifting both may represent early Tertiary events.

The St. Lawrence and Stuart subbasins resulted from multiphase extensional tectonism expressed as differential, nonsynchronous subsidence along normal faults. There appear to be significant intra-fill unconformities present in both subbasins. Lithologic, dipmeter, geophysical, and geochemical evidence for the lowest unconformity is best developed in the No. 2 well. This surface may have formed contemporaneously with or preceded initial uplifting of the horst. The ambiguous evidence for angularity seen on one public seismic line suggests that the unconformity was in part tectonically controlled. Eustatic changes that resulted in lower base level may be invoked as an alternative or ancillary to tectonism. Calculations made from vitrinite reflectance values (following the method of Dow, 1977) suggest that perhaps 1000 feet of section may be

missing in the No. 2 well. A more subtle maturity anomaly of less magnitude is present in the No. 1 well for which no missing section could be calculated. If this lower unconformity separates early and middle Eocene rocks, the erosion was relatively rapid. The unconformity could also be interpreted as a marine transgressive event if the depositional nature of the Oligocene or older section of the No. 1 well was less equivocal and the position of the unconformity in the No. 2 well was moved up to the base of the transitional interval at 11,960 feet (a better geochemical fit, rather than the 12,700 feet dipmeter pick). Samples and other data from this interval in both wells are being reprocessed and reevaluated in hopes of clearing up these ambiguities. Aside from the major unconformity between Paleozoic and Cenozoic rocks, and the mid-Eocene (?) unconformity discussed above, two other unconformities were identified, a Pliocene-Pleistocene unconformity discernible on shallow seismic lines and a mid-Miocene hiatus based on siliceous microfossils.

Perhaps the most intriguing deviation from the predicted basin model concerns the nature of Paleogene deposition. On the basis of scattered outcrops of nonmarine Paleogene rocks around Norton Sound, the presumed nonmarine nature of sediments of this presumed age in the Hope basin, and reference to the Anadyr basin as an analog, Fisher and others (1982) speculated that the Paleogene section of the Norton basin contained only nonmarine rocks. In fact, both wells contain significant thicknesses of Paleogene age marine strata. If, as postulated by Herman and Hopkins (1980), the Bering Sea land bridge separated the Pacific and Arctic oceans until 3.5 m.y. ago, this Paleogene marine connection was probably an arm of the Pacific, and the Nunivak arch of Scholl and Hopkins (1969) and Marlow and others (1976) was not the barrier to Paleogene marine incursions postulated by Fisher and others (1982). Alternatively, the

seaway between the eastward moving Siberian block (the Chukotsk and Seward peninsulas) and mainland Alaska may not have been entirely closed at the end of the Cretaceous as postulated by Sachs and Strelkov (1961) and Holmes and Creager (1981). It is also conceivable that an Arctic connection could have been reestablished through lows over the Seward Peninsula before major late Cenozoic uplifts. The presence of Paleogene foraminiferal faunas with strong affinities to those of Sakhalin Island and the Kamchatka Peninsula supports a Pacific rather than Arctic connection. In particular, the presence of species Porosorotalia, a predominantly austral Pacific Paleogene foraminiferal genus, lends further credence to this interpretation.

Of the two wells, the No. 1 is by far the most marine in aspect. Nearly 5000 feet of the 5197 foot thick Oligocene section was deposited in outer neritic to upper bathyal depths. If the apparent turbidites below it (tentatively correlated with the middle to late Eocene section in the No. 2 well) are also marine, then virtually the entire Paleogene section, with the exception of 310 feet of coal-bearing sediments of possible Eocene or older age, is marine. More than half of the 6536 foot Oligocene section in the No. 2 well is made up of shelfal marine sediments; the remainder consists of coal-bearing transitional sediments deposited in marsh and estuarine environments under marine influences. The Eocene section also reflects significant transitional conditions, and definite marine fossils are present as deep as 11,200 feet. All in all, there is probably less than 2400 feet cumulative thickness of purely continental Paleogene section present in the No. 2 well. The late Oligocene coal-bearing sequence described in both wells (our D seismic horizon) is in part correlative with coals of the same age reported from near Unalakleet (Patton, 1973; W.

Patton, written communication) and from St. Lawrence Island by Csejtey and Patton (1974). These strata appear to define a regional regressive event that may have continued into the earliest Miocene.

The Yukon horst does not appear to have been a major barrier between the two subbasins until after the mid-Eocene (?) erosional event with which it may be causally related. Thereafter the subbasins had somewhat different tectonic and depositional histories until the mid-Oligocene transgressive event that breached the elongate north-south structure. Subsidence after this time appears to have been a basin-wide isostatic response to sediment loading, and for the first time deposition extended beyond the independent, structurally delineated subbasins. Although deposition in the St. Lawrence subbasin (No. 1 well) was always more marine than in the more easterly situated Stuart subbasin (No. 2 well), the Yukon horst was not an altogether effective physical or faunal barrier as evidenced by the presence of fossiliferous marine stringers intercalated with continental and transitional coals throughout the Eocene and Oligocene section of the No. 2 well.

The most difficult equivalency to establish is that between the problematic Oligocene or older nonfossiliferous turbidites (?) of the No. 1 well and the middle to late Eocene transitional to continental coal-bearing section of the No. 2 well (as was noted in the discussion of the unconformity at the base of both). Small chips of unweathered glaucophane schist in cuttings from this section of the No. 1 well indicate rapid erosion from a nearby source, probably the horst. If these well sections are correlative, as we now believe, then the

presence of Eocene marine fossils in the No. 2 well makes a lacustrine origin for the turbidite section of the No. 1 well (9690-12,235 feet) difficult to explain in terms of simple paleogeography. Geochemical evidence for a lacustrine environment is not compelling. The dominant organic material present over the interval is type III kerogen associated with minor amounts of possible type II kerogen. Type I kerogen, especially alganite, is the type of organic material characteristic of large lacustrine depositional systems. Only one sample (from a conventional core at 9758 feet) yielded an analysis that might represent type I kerogen.

On the basis of source, maturity, structure, and potential reservoirs, the Paleogene section of the Norton basin is the most prospective for petroleum. The Neogene section penetrated by the two test wells conformed rather well to expectations of thickness, character, and hydrocarbon potential. Perhaps a thicker Miocene section elsewhere in the basin might have more potential. At first glance it would appear that the Paleozoic section consists of nonprospective metamorphics. Nothing seen in either well strongly contradicts that negative assessment. However, minor amounts of marble were cored in the lower part of the No. 2 well, and a thick sequence of Paleozoic carbonates is present on the Seward Peninsula. It is possible that potential Paleozoic carbonate reservoirs, perhaps enhanced by pre-mid-Oligocene karsting, are present on the horst. The cataclastically sheared slate and marble seen in the No. 1 well might also develop reservoir qualities in some settings. A much more thorough understanding of the age and structural relationships of the rocks of the basement complex is necessary before its potential as an exploration play can be addressed. Although

the pattern observed on the Seward Peninsula by Sainsbury and others (1970) of increasing metamorphic grade eastward appears to hold in the Norton Sound wells, it may be more perceived than real. Studies on these rocks currently underway should help elucidate the complex geologic history of the nearby Seward Peninsula, as well as the evolution of the Norton Basin.

ARCO Norton Sound COST No. 1 Well Summary

The ARCO Norton Sound COST No. 1 well was drilled to a measured depth of 14,683 feet. The KB was 98 feet above sea level and 188 feet above mudline. The water depth was 90 feet. The wellsite was approximately 54 miles south of Nome, Alaska. Drilling commenced on June 14, 1980 and was completed in 94 days on September 16, 1980. The well was drilled from the Dan Prince, a self-elevating drilling rig that was later lost to a storm in the Gulf of Alaska while enroute under tow to a new location. Drilling rates ranged from 3 to 1296 feet per hour. Four strings of casing were set during drilling: 30 inch to 294 feet, 20 inch at 1206 feet, 13 3/8 inch at 4667 feet, and 9 5/8 inch at 12,170 feet. The drilling fluid program was as follows: sea water to 450 feet, 8.9 pounds/gallon gel and water mud to 6250 feet, 10 pounds/gallon from 6250 to 12,200 feet, and 10.4 pounds/gallon from 12,200 to 14,683, the total depth.

Twelve conventional cores, 533 percussion sidewall cores, and many well cuttings were analyzed for porosity, permeability, lithology, hydrocarbon content, and paleontology. Rotary drill bit cuttings were collected from 180 to 14,683 feet.

Logging runs were made at depths of 4670, 12,175, and 14,683 feet. A Compensated Neutron Log (CNL) with Neutron Gamma Tool (NGT), Compensated Formation Density Log (FDC), Borehole Compensated Sonic Log (BHC), Long Spaced Sonic Log (LSS) with Integrated Travel Time (ITT), Proximity Log-Microlog (MPL), Caliper Log, High Resolution Continuous Dipmeter (HRT), and Velocity Survey were recorded on all runs. On the second and third runs the Dual Induction Laterlog (DIL) and Repeat Formation Test (RFT) were run. On the final run three logs were added to the suite, a Temperature Survey, Cement Bond Log (CBL), and Micro-Laterolog (MLL). Two formation tests were made.

As required by 30 CFR 251, the operator (ARCO) filed a Drilling Plan, Environmental Analysis, Oilspill Contingency Plan, and Coastal Zone Management Certification. In addition, geohazards, geotechnical, and site-specific biological surveys were required. The zooplankton, infauna, epifauna, vagile benthos, and pelagic fauna were collected and analyzed. Particular emphasis was placed on protecting local and migratory marine mammals and avifauna. Waste discharges into the environment were minimal, nontoxic, and in compliance with Federal environmental protection regulations.

Stratigraphic units in the No. 1 well were defined on the basis of microfossil content, lithological and log characteristics, correlation with the No. 2 well, seismic character, and absolute dating techniques. The strata penetrated by the Norton Sound COST No. 1 well were Pleistocene from 180 to

1320 feet, Pliocene from 1320 to 2637 feet, Miocene from 2637 to 4493 feet, and Oligocene from 4493 to 9690 feet. The interval from 9690 to 12,235 feet is Oligocene or older and is tentatively correlated with the middle to late Eocene section of the No. 2 well. The interval from 12,235 to 12,545 feet is considered correlative with the Eocene or older section of the No. 2 well. The well penetrated 2138 feet of cataclastic metasedimentary rocks similar to Precambrian (?) to Paleozoic slates exposed in the York Mountains on the Seward Peninsula. Deposition was almost entirely marine throughout except approximately 200 feet of transitional sediments in the upper part of the Oligocene section, and 310 feet of continental (fluvial and paludal) in the possible Eocene or older section.

Samples from the Pleistocene section were sporadic, of poor quality, and consisted primarily of unconsolidated shelly sand, lithic fragments, mud and silt. The Pliocene section is predominantly a diatomaceous sandy mudstone with thin stringers that can be characterized as muddy diatomites. The Miocene section consists of sandy, diatomaceous mudstones similar to those of the Pliocene. The Oligocene section is characterized by thin, transitional deposits of sandstone, siltstone, and coal near the top of the unit, and marine mudstone, shale, and sandstone from 4770 to 9690 feet. The Oligocene or older section consists of mudstone and micaceous sandstone, often displaying graded bedding. The interval from 10,300 to 10,640 feet contains tabular igneous rocks (basalt and trachyte) that may represent either sills or flows. The possible Eocene or older section consists of interbedded sandstone, siltstone, shale, coal, and conglomerate. The section from 12,545 to 14,683 feet consists of cataclastically metamorphosed pelitic rock (slate) and minor amounts of marble and is thought to be late Precambrian to Paleozoic in age.

Sandstone porosities of greater than 24 percent are restricted to depths of less than 6000 feet in the No. 1 well. Sandstones in this well must have at least 24 percent porosity in order to have 1 mD permeability. Pore reduction was the result of ductile grain deformation, authigenic mineral growth, and cementation.

Geochemical data indicate that the most common organic material present is Type III humic kerogen. Sufficient maturity for the generation of oil from this type of kerogen exists below 9500 feet. Dry gas and wet gas condensate are more likely, however. Below 13,000 feet there is insufficient organic carbon to serve as a commercial hydrocarbon source.

A thermal gradient of 2.01° to 2.44°F per 100 feet was calculated.

Four seismic horizons were mapped and correlated: the basement unconformity (A), igneous sills or flows (B-2), mid-Oligocene transgressive marine facies (C), and late Oligocene regressive facies (D).

Interval velocities calculated from the sonic log are in agreement with those from nearby stacking velocities to a depth of 6100 feet. Below this depth the comparatively higher interval velocities probably are a function of different collection methods. Lithologic differences between the two subbasins probably account for the steeper time-depth curve in the No. 2 well than in the

No. 1 well. Depth conversions of seismic data should consider velocity variations between the subbasins. Check shot data (velocity survey) could not be published or utilized in this study because of its longer proprietary term (USGS, Conservation Division, Policy Paper, January 22, 1982).

REFERENCES

- Anderson, Warren and Associates, Inc., 1980, Norton Basin COST No. 1 Well Paleontology Report: 32 p., 3 fig.
- Anstey, N. A., 1977, Seismic Interpretation: The Physical Aspects: International Human Resource Development Corporation, Boston, 625 p.
- ARCO Oil and Gas Company, undated, Environmental Analysis for Norton Sound COST No. 1: Anchorage, Alaska.
- Barker, C., 1974, Pyrolysis Techniques for Source-Bed Evaluation: Bulletin of the American Association of Petroleum Geologists, Vol. 58, p. 2349-2361.
- Barron, John, 1980, Lower Miocene to Quaternary diatom biostratigraphy of leg 57, off northeastern Japan Sea Drilling Project, Initial Reports: D.S.D.P. Leg 57, p. 641-686.
- Bayliss, G. S., 1980, Hydrocarbon source facies analysis COST Norton Basin Well, Norton Sound, Alaska: Geochem Laboratories, Inc., 18 p., fig.

- Bott, M. H. P., 1976, Formation of sedimentary basins of grabben type by extension of the continental crust: *Tectonophysics*, vol. 36, no. 1, p. 77-86.
- Brouwers, Elizabeth, (in press), Ostracode assemblages from Boreholes HLA 17 and 18, western Beaufort Sea, northern Alaska, appendix G: Environmental Assessment of the Alaska Continental Shelf, Bureau of Land Management/ National Oceanic and Atmospheric Administration.
- Bouma, A. H., 1962, *Sedimentary of some flysch deposits*: Amsterdam, Elsevier Publishing Company, 168 p.
- Claypool, G. E., and Reed, P. R., 1976, Thermal-analysis technique for source rock evaluation: Quantitative estimates of organic richness and effects of lithologic variation: *Bulletin of the American Association of Petroleum Geologists*, Vol. 60, No. 4, p. 608-626.
- Crimes, T. P., 1970, The significance of trace fossils in sedimentology, stratigraphy, and paleoecology with examples from Lower Paleozoic strata: in Crimes, T. P., and Harper, J. C., eds., *Trace Fossils*, *Geological Journal Special Issue No. 3*, p. 101-126.
- Csejtey, Bela, and Patton, W. W., 1974, Petrology of the nepheline syenite of St. Lawrence Island, Alaska: *Journal Research, U.S. Geological Survey*, Vol. 2, No. 1, January-February, 1974, p. 41-47.

- Davey, R. J., Downie, Charles, Sarjeant, W. A. S., and Williams G. L., 1966, Studies on Mesozoic and Cainozoic dinoflagellate cysts: Bulletin British Museum (Natural History), Geology Supplement 3, 248 p., 26 pl., 64 text-figs.
- Demaison, G., 1981, Stratigraphic aspects of source bed occurrence. The organic facies concept: In Geochemistry for Geologists, AAPG Geochemistry for Geologists, (Short Course Notes), Dallas, Texas, 1981, 101 p.
- Demshur, D. M., and Swetland, P. J., 1980, Hydrocarbon source-bed evaluation, Norton Basin COST No. 1, Norton Sound, Alaska: Core Laboratories, Inc., 129 p.
- Dow, W. G., 1977, Kerogen studies and geological interpretations: Journal of Geochemical Exploration, Vol. 7, No. 2, p. 79-99.
- Dow, W. G., and O'Connor, D. J., 1981, Kerogen maturity and type by reflected light microscopy applied to petroleum exploration: In Geochemistry for Geologists, AAPG Geochemistry for Geologists, (Short Course Notes), Dallas, Texas, 1981, 27 p.
- Espitalie, J., Laporte, J. L., Madec, M., Marquis, F., Leplat, P., Paulet, J., and Boutefeu, A., 1977, Methode rapide de caracterisation des roches meres, de leur potentiel petrolier et de leu degre d'evolution: Rev. J l'Inst. Francais Petrol., 32 (1), p. 23-42.

Fisher, M. A., Patton, W. W., and Holmes, M. L., 1982, Geology of Norton Basin and continental shelf beneath northwestern Bering Sea, Alaska: American Association of Petroleum Geologists Bulletin, v. 66, No. 3, p. 255-285.

Forbes, R. B., Evans, B. W., and Pollock, S., 1981, The Nome Group blueschist terrane: a possible extension of the Brooks Range Schist Belt: Geological Society of America; 77 Annual Meeting, Senora, Mexico, Abstracts with Program, Cordilleron Section, Vol. 13, No. 2, p. 56.

Fuex, A. N., 1977, The use of stable isotopes in hydrocarbon exploration: Journal of Geochemical Exploration, Vol. 7, No. 2, p. 155-188.

Gladenkov, Y. B., 1977, Stages in the evolution of mollusks and subdivisions of the North Pacific Neogene: First International Congress on Pacific Neogene Stratigraphy, Tokyo, 1976, Proceedings, p. 89-91.

Herman, Yvone, and Hopkins, D. M., 1980, Arctic ocean climate in the late Cenozoic time: Science, vol. 209, August 1, p. 557-562.

Holmes, M. L., and Creager, J. S., 1981, The role of the Kaltag and Kobuk faults in the tectonic evolution of the Bering Strait region: in D. W. Hood and J. A. Calder, eds., The eastern Bering Sea shelf and resources, p. 293-302.

- Hoose, P. J., Steffy, D. A., and Lybeck, L. D., 1981, Isopach map of Quaternary and upper Tertiary strata, Norton Sound, Alaska: U.S. Geological Survey Open-File Report 81-723, 1 oversized sheet, scale 1:250,000.
- Hudson, Travis, 1979, Igneous and metamorphic rocks of the Serpentine Hot Springs areas, Seward Peninsula: U.S. Geological Survey Professional Paper 1079, 27 p.
- Hunt, J. M., 1979, Petroleum Geochemistry and Geology: San Francisco, W. H. Freeman and Company, 617 p.
- Hyndman, D. W., 1972, Petrology of igneous and metamorphic rocks: New York, McGraw-Hill Book Company, 533 p.
- Koizumi, Itaru, 1973, The Late Cenozoic diatoms of sites 183-193, leg 19 Deep Sea Drilling Project, Initial Reports: D.S.D.P. Leg 19, p. 505-856.
- Larsen, M. C., Nelson, C. H., and Thor, D. R., 1980, Sedimentary processes and potential geologic hazards on the sea floor of northern Bering Sea, 32 p., in Larsen, M. C., Nelson, C. H., and Thor, D. R., eds., Geological, geochemical, and geotechnical observations on the Bering Shelf, Alaska: U.S. Geological Survey Open-File Report 80-979.

Larskaya, Ye S., and Zhabrev, D. H., 1964, Effects of stratal temperatures and pressures on the composition of dispersed organic matter from the example of the Mesozoic-Cenozoic deposits of the western Ciscaspian region: Dokl. Akad. Nauk SSSR, 157 (4), p. 135-139.

Lentin, J. K., and Williams, G. L., 1977, Fossil dinoflagellates: Index to Genera and Species: Bedford Institute of Oceanography Rept. Serv. BI-R-77-8, 209 p.

Marlow, M. S., Scholl, D. W., Cooper, A. K., and Buffington, E. C., 1976, Structure and evolution of the Bering Sea shelf south of St. Lawrence Island: AAPG Bulletin, Vol. 60, No. 2, p. 161-183.

Menner, V. V., Baranova, Y. P., and Zhidkova, L. S., 1977, Neogene of the Northeastern U.S.S.R. (Kolyma Region, Kamchatka, and Sakhalin): First International Congress on Pacific Neogene Stratigraphy, Tokyo, 1976, Proceedings, p. 83-88.

Minerals Management Service, 1982, Guidelines for collection of meteorological, oceanographic, and performance data: Anchorage, Alaska.

Minerals Management Service, Offshore Field Operations, Deputy Minerals Manager, 1980, OCS Environmental Assessment No. AK-80-1: Alaska Region, Anchorage, Alaska.

- Miyashiro, Akiho, 1974, Volcanic rock series in island arcs and active continental margins: *American Journal of Science*, v. 274, p. 321-355.
- Mutti, E., and Ricci, Lucchi, F., 1972, Le torbidii dell' Appennino settentrionale: introduzione all' analisi di facies: *Memorie della Societa' Geologica Italiana*, v. 11, p. 161-199.
- Nelson, C. H., 1980, Late Pleistocene-Holocene transgressive sedimentation in deltaic and non-deltaic areas of the Bering epicontinental shelf, 30 p., in Larsen, M. C., Nelson, C. H., and Thor, D. R., eds. Geological, geochemical, and geotechnical observations on the Bering Shelf, Alaska: U.S. Geological Survey Open-File Report 80-979.
- Park, R., and Epstein, S., 1960, ^{13}C in lake waters and its possible bearing on paleolimnology: *American Journal of Science*, Vol. 258, p. 253-272.
- Patton, W. W., 1973, Reconnaissance geology of the northern Yukon-Koyukuk Province, Alaska: U.S. Geological Survey Professional Paper 774-A, 17 p.
- Patton, W. W., and Csejtey, Bela Jr., 1971, Preliminary geologic investigations of western St. Lawrence Island, Alaska: U.S. Geological Survey Professional Paper 684-C, 15 p.

- Phillippi, G. T., 1957, Identification of oil-source beds by chemical means: 20th International Geological Congress, Proceedings, Mexico City, 1956, Sec. 3, pp. 25-28.
- Powell, T. G., and McKirdy, D. M., 1975, Geologic factors controlling crude oil composition in Australia and Papua, New Guinea: Bulletin of the American Association of Petroleum Geologists, Vol. 59, No. 7, p. 1176-1197.
- Sachs, V. N., and Strelkov, S. A., 1961, Mesozoic and Cenozoic of the Soviet Arctic: in G. O. Raasch, ed., Geology of the Arctic, Univ. Toronto Press, p. 48-67.
- Sainsbury, C. L., Coleman, R. G., and Kachadoorian, R., 1970, Blueschist and related greenschist facies rocks of the Seward Peninsula, Alaska: U.S. Geological Survey Professional Paper 700B, p. B33-B42.
- Scholl, D. W., and Hopkins, D. M., 1969, Newly discovered Cenozoic basins, Bering Sea shelf, Alaska: AAPG Bulletin, Vol, 53, p. 2067-2078.
- Schrader, Hans, 1973, Cenozoic diatoms from the northeast Pacific, leg 18, Deep Sea Drilling Project, Initial Reports: D.S.D.P. Leg 18, p. 673-798.
- Serova, M. Y., 1976, The Caucasina eocenica kamchatica Zone and the Eocene-Oligocene boundary in the northwestern Pacific: Progress in Micropaleontology, p. 314-328, 1 pl., 1 text fig., 3 tbls.

- Sheriff, R. E., 1978, A first course in geophysical examination and interpretation: International Human Resource Development Corporation, Boston, 313 p.
- Silverman, S. R., 1964, Investigations of petroleum origin and mechanisms by carbon isotope studies: In S. L. Miller and G. J. Wasserburg (eds.), Isotopic and Cosmic Chemistry: Amsterdam, North-Holland Publishing Company, p. 92-102.
- Silverman, S. R., and Epstein, S., 1958, Carbon Isotopic composition of petroleums and other sedimentary organic materials: Bulletin of the American Association of Petroleum Geologists, Vol. 42, No. 5, p. 998-1012.
- Smith, P. S., 1910, Geology and mineral resources of the Solomon and Casadepage quadrangles, Seward Peninsula, Alaska: U.S. Geological Survey Bulletin 433, 234 p.
- Snowdon, L. R., 1980, Resinite - a potential petroleum source in the Upper Cretaceous/Tertiary of the Beaufort MacKenzie basin: In, A. D. Miall, eds., Facts and principles of world petroleum occurrence, Canadian Society of Petroleum Geologists Memoir 6, p. 421-446.

- Snowdon, L. R., and Powell, T. G., 1982, Immature oil and condensate-modification of hydrocarbon generation model for terrestrial organic matter: Bulletin of the American Association of Petroleum Geologists, Vol. 66, No. 6, p. 775-788.
- Staplin, F. L., 1969, Sedimentary organic matter, organic metamorphism and oil and gas occurrence: Bulletin of Canadian Petroleum Geology, Vol. 17, No. 1, p. 47-66.
- Steffy, D. A., and Hoose, P. J., 1981, Map showing acoustic anomalies and near-surface faulting, Norton Sound, Alaska: U.S. Geological Survey Open-File Report 81-722, 1 oversized sheet, scale 1:250,000.
- Steffy, D. A., and Lybeck, L. D., 1981, Map showing selected geologic features, Norton Sound, Alaska: U.S. Geological Survey Open-File Report 81-721, 1 oversized sheet, scale 1:250,000.
- Steffy, D. A., Turner, B. W., and Lybeck, L. D., 1981, Bathymetric map of Norton Sound, Alaska: U.S. Geological Survey Open-File Report 81-719, 1 oversized sheet, scale 1:250,000.
- Steffy, D. A., Turner, B. W., Lybeck, L. D., and Roe, J. T., 1981, Isopach map of Holocene sedimentary units, Norton Sound, Alaska: U.S. Geological Survey Open-File Report 81-720, 1 oversized sheet, scale 1:250,000.

- Stover, L. E., and Evitt, W. R., 1978, Analyses of pre-Pleistocene organic-walled dinoflagellates: Stanford University Publications, 300 p. 6 tbls.
- Tetra Tech, Inc., 1979a, Interpretative Report on COST Site No. 1 and 2 Site-Specific Hazard Survey, Norton Sound, Alaska, Report to ARCO Oil and Gas Company: Anchorage, Alaska.
- Tetra Tech, Inc., 1979b, Marine Biological Survey at Proposed Continental Offshore Stratigraphic Test No. 1 - Norton Sound, Alaska. Report to ARCO Oil and Gas Company: Anchorage, Alaska.
- Till, A. B., 1982, Granulite, peridotite, and blueschist - early tectonic history of the Seward Peninsula, Alaska [abs]: Alaska Geological Society Symposium, Anchorage, Alaska, 1982, Proceedings, Alaska Geological Society, p. 33-35.
- Tipsword, H. L., Setzer, F. M., and Smith, F. L., Jr., 1966, Interpretation of depositional environments in Gulf Coast petroleum exploration from paleoecology and related stratigraphy: Gulf Coast Association Geological Societies Transactions, Vol. XVI, p. 119-130.
- Tissot, B. P. and Welte, D. H., 1978, Petroleum Formation and Occurrence: Berlin Heidelberg New York, Springer-Verlag, 538 p.

Van Krevelen, D. W., 1961, Coal: New York, Elsevier, 514 p.

Voloshinova, N. A., Kuznetsova, V. N., and Leonenko, L. S., 1970, Neogene Foraminifera of Sakhalin: Proceedings all Union Petroleum Scientific Research, Geological Exploration Institute (translated from Russian by the National Translation Service, TT 76-53241), 608 p., 51 pl.

Williams, G. L., and Bujak, J. P., 1977, Cenozoic Palynostratigraphy of Offshore Eastern Canada: American Association of Stratigraphic Palynologists, Contribution Series No. 5A, p. 14-48, 5 pl., 9 text-figs.

Wolfe, J. A., 1977, Paleogene floras from the Gulf of Alaska: U.S. Geological Survey Professional Paper 997, 108 p., 30 pl.

Woodward-Clyde Consultants, 1979, Geotechnical Investigation Program and Siting Study for Jack-Up Rig Footing Behavior in Norton Sound Offshore Alaska, Report to Tetra Tech, Inc., Anchorage, Alaska.

APPENDIX

Well Data and Consultants Reports Available for Public Inspection, Norton Sound COST No. 1 Well

Schlumberger Offshore Services Anchorage, Alaska

- 2 in. Borehole Compensated Sonic Log
Runs 1, 2, 3 1210-14,676 ft
- 5 in. Borehole Compensated Sonic Log
Runs 1, 2, 3 1210-14,676 ft
- 5 in. Borehole Geometry Log
Run 1 1210-4670 ft
- 5 in. Borehole Geometry Log
Run 2 4666-12,172 ft
- 5 in. Borehole Geometry Log
Run 2 4666-12,172 ft
- 5 in. Borehole Geometry Log
Run 3 12,166-14,682 ft
- 5 in. Cement Bond Log Variable Density
Run 3 10,166-12,166 ft
- 2 in. Compensated Formation Density Log Gamma-Gamma
Runs 1, 2, 3 3575-14,682 ft
- 5 in. Compensated Formation Density Log Gamma-Gamma
Runs 1, 2, 3 3575-14,682 ft
- 2 in. Compensated Neutron Formation Density
Runs 1, 2, 3 1206-14,682 ft
- 5 in. Compensated Neutron Formation Density
Runs 1, 2, 3 1206-14,682 ft
- 5 in. Continuous Dipmeter
Run 1 1210-4670 ft
- 5 in. Continuous Dipmeter
Run 2 4666-12,172 ft
- 5 in. Cyberdip
Run 1 1210-4670 ft

Schlumberger (continued)

5 in. Cyberdip
Run 2 4666-12,170 ft

5 in. Cyberdip
Run 3 12,166-14,676 ft

2 in. Cyberlook
Run 1 1210-4670 ft

5 in. Cyberlook
Run 1 1210-4670 ft

2 in. Cyberlook
Pass 1 Run 2 4666-12,170 ft

5 in. Cyberlook
Pass 1 Run 3 12,166-14,682 ft

2 in. Cyberlook
Pass 1 Run 3 12,166-14,682 ft

2 in. Dual Induction - SFL
Runs 1, 2, 3 1210-14,676 ft

5 in. Dual Induction - SFL
Runs 1, 2, 3 1210-14,676 ft

2 in. Dual Induction - SFL w/Linear Correlation Log
Runs 1, 2, 3 1210-14,676 ft

5 in. High Resolution Thermometer
Run 3 100-14,660 ft

2 in. Long Spaced Sonic Log
Runs 1, 2, 3 1210-14,660 ft

5 in. Long Spaced Sonic Log
Runs 1, 2, 3 1210-14,660 ft

5 in. Long Spaced Sonic Waveforms 8 ft-10 ft-12 ft
Run 1 1210-4660 ft

5 in. Long Spaced Sonic Waveforms 8 ft-10 ft-12 ft
Run 3 12,166-14,660 ft

2 in. Microlog
Run 1 1206-4670 ft

Schlumberger (continued)

2 in. Microlog

Run 2 4660-12,171 ft

2 in. Microlog

Run 3 12,166-14,682 ft

5 in. Microlog

Run 1 1206-4670 ft

5 in. Microlog

Run 3 12,166-14,682 ft

2 in. Natural Gamma Ray Tool

Runs 1, 2, 3 1210-13,000 ft

5 in. Natural Gamma Ray Tool

Runs 1, 2, 3 1210-13,000 ft

2 in. Proximity Log

Run 1 1206-4670 ft

2 in. Proximity Log

Run 2 4666-12,172 ft

5 in. Proximity Log

Run 1 1206-4670 ft

5 in. Proximity Log

Run 2 4660-12,172 ft

5 in. Proximity Log

Run 3 12,166-14,682 ft

Repeat Formation Tester

Run 2 Test No. 1-13 8/14/80

High Resolution Dipmeter Cluster Listing

Run 3

Analyst Mud Log Sepia

200-14,682 ft

IDEL Log Sepia

250-14,682 ft

Shale Density Log Sepia

200-14,682 ft

Delta Chloride Log Sepia

300-14,682 ft

Schlumberger (continued)

D Exponent Sepia
294-14,682 ft

Christianson Diamond Products Co.
Salt Lake City, Utah

Sidewall Core Run #2
4700-12,155 ft

Coring Logs, 12 Reports C
Core 1-12

ARCO Alaska Inc.
Anchorage, Alaska

Paleomagnetic Measurements on Diamond Core Samples from Norton Sound
and St. George Basin Alaska COST Wells, 1 volume.

Wellsite Core Descriptions, 13 p.
Cores 2-12

Wellsite Sidewall Sample Descriptions, 20 p.
Run 1 1214-4660 ft
Run 2 1274-4660 ft
Run 3 1223-4630 ft

Wellsite Sidewall Sample Descriptions, 20 p.
Runs 1-7 4701-12,156.5 ft

Wellsite Sidewall Sample Descriptions, 16 p.
93 shots 12,180-14,670 ft

Log Quality Control Survey
Runs 1, 2, 3

APD, Sundry Notices, Well Completion Report
104 p.

Drill Stem Test Procedures,
1 and 2, 2 p.

Core Laboratories, Inc.
Dallas, Texas

Core Analysis Reports
Cores 4, 7, 8, 9, 10; 5 p.

Sidewall Core Analysis Reports
4736-12,140 ft, 2 p.

Core Photographs
19 photos, 1 vol.

Core Samples Geochemical Data
10,396, 10,887, 10,955, 12,399, 13,592 ft

Hydrocarbon Source Bed Evaluation
Final Report

AGAT Consultants, Inc.
Denver, Colorado

Reservoir Quality Analysis

Lithologic Analysis of Core and Sidewall Sample
1 vol.

Petrography of Acoustic Velocity Samples
1 vol.

Birdwell Division
Seismograph Service Corporation
Tulsa, Oklahoma

Seismic Velocity Report and Calibration
1 vol.

Vertical Seismic Profile Sepia

Geochron Laboratories
Cambridge, MA

K-AR Age Determinations
JM-0 - JM-10 and JM-13 and Phyllite Sample
13 reports

Geochem Laboratory
Houston, Texas

Hydrocarbon Source Facies Analysis

Management Summary Report
Hydrocarbon Source Facies Analysis

Anderson, Warren Associates
San Diego, California

Biostratigraphic Report w/charts

Chemical and Geological Laboratories of Alaska, Inc.
Anchorage, Alaska

Water Analysis Reports (3)

Minerals Management Service
Anchorage, Alaska

Environmental Assessment

