

Potential Impacts to Marine Mammals and Sea Turtles from Offshore Wind

Research Framework Workshop New England Wind Energy Areas

30 May–31 May 2018
New Bedford, Massachusetts

Proceedings
Finalized 10 April 2019



Prepared by the Consensus Building Institute
Patrick Field, *Managing Director*
Rebecca Gilbert, *Associate*

Acknowledgements

The research framework workshop was sponsored by the Bureau of Ocean Energy Management, the Massachusetts Clean Energy Center (MassCEC), and the Anderson Cabot Center for Ocean Life at the New England Aquarium. Funding for facilitation of the workshop and preparation of the research framework was provided by MassCEC. The sponsors express their sincere appreciation to workshop participants listed in Appendix B.

Table of Contents

Table of Contents	3
Executive Summary	5
1.0 Purpose and Context	8
1.1 Overview	8
1.2 Background	8
1.3 Framework Scope and Application	8
1.4 Workshop Purpose and Format	9
1.5 Offshore Wind Developers' Perspective	9
1.6 Remarks by EEA Secretary Matthew Beaton	10
1.7 Regulatory Context	10
1.8 Industry Context	11
2.0 Overview of Current Knowledge	11
2.1 Summary of European studies on the effects and monitoring of wind facility construction and operation	11
2.1.1 Using acoustic methods	11
2.1.2 Using aerial and shipboard surveys	13
2.2 MassCEC/BOEM large whale and turtle surveys of the MA and RIMA Wind Energy Areas	16
2.2.1 Aerial survey results	16
2.2.2 Acoustic survey results	17
2.2.3 Prey sampling/oceanographic data results	18
3.0 Developing Hypotheses and Experimental Design	20
3.1 Preliminary review of hypotheses and questions	20
3.2 Testing hypotheses	21
3.3 Potential data collection methods	22
4.0 Testing Effects of Construction Hypotheses – Short-term	29
4.1 Current understanding of potential short-term construction impacts	29
4.2 General categories of short-term impact research	29
4.2.1 Species to study	29
4.2.2 Scientific hypotheses	31
4.2.3 Study designs to address hypotheses – small group discussions	32
5.0 Testing Effects of Construction Hypotheses – Long-term	38
5.1 Current understanding of long-term construction impacts	38
5.2 General categories of long-term potential impact research	38
5.2.1 Species	39

5.2.2 Scientific hypotheses	39
5.2.3 Experimental designs to address hypotheses – small group discussions	40
6.0 Outstanding Questions	42
Appendix A: Final Agenda	43
Appendix B: List of Participants	47
Appendix C: Research Questions and Hypotheses Matrix	48
Appendix D: Draft Experimental Outline: Short-term effects	55
Appendix E: Draft Experimental Outline: Long-term effects	57

Executive Summary

The Massachusetts Clean Energy Center (MassCEC), the Massachusetts Executive Office of Energy and Environmental Affairs, the Bureau of Ocean Energy Management (BOEM), and the New England Aquarium (NEAq) convened a workshop on 30 and 31 May 2018 that included marine scientists, NGO representatives, regulators, public stakeholders, and offshore wind leaseholders to inform the development of a scientific research framework (the “Framework”) to guide studies of potential impacts to endangered whales and sea turtles associated with offshore wind facility construction and operation in the U.S. Northeast.

Baleen whales and sea turtles are migratory species that rely on North Atlantic waters for all aspects of their life history. Recent surveys of wind energy areas offshore of Massachusetts and Rhode Island have documented their presence in the area at various times of the year. In order to assess the ecological impacts of offshore wind facility construction and operation on marine mammals and sea turtles in U.S. waters, a carefully designed research plan is needed. Because of multiple variables, changing oceanic conditions, and inter-annual variability, any such research to determine effects will require careful experimental design, appropriate statistical methods, and data collection methods designed to collect adequate sample sizes.

This Proceedings seeks to capture the key discussions, ideas, and questions raised by participants in the workshop. The Proceedings also serves to inform the marine mammal and wind research framework being developed by the workshop’s technical Co-Chairs, Professor Len Thomas, Center for Research in Ecological and Environmental Monitoring (CREEM), and Dr. Scott Kraus, New England Aquarium (NEAq). The workshop raised a number of questions that are captured, though not necessarily answered, in the Proceedings. Key questions, as identified by the participants, will help to inform the hypotheses to test in the research Framework.

The Framework will identify a strategy to assess potential population-level impacts to marine mammals and sea turtles associated with offshore wind facility construction and operation. The framework will address two separate components to this. One revolves around the short-term effects of short-term construction activities at the project-specific scale. The larger question revolves around the long term effects of and potential population-level impacts of windfarm placement and operations on distribution, abundance, behavior, or demography of endangered marine mammals and sea turtles.

The Framework will be developed with a focus on assessing potential impacts to baleen whales and sea turtles associated with offshore wind facility construction and operation within the Massachusetts and Rhode/Island Massachusetts Wind Energy Areas (MA and RIMA WEAs) since sufficient current biological data exist, and offshore wind facility construction is anticipated to begin in the foreseeable future. However, the intention of the Framework is to make it applicable to address other offshore wind development along the Atlantic coast. The final Framework will contain preliminary experimental designs that address research questions and hypotheses identified by participants during the workshop.

The goal of the workshop was to convene key stakeholders and subject matter experts in order to elicit critical information necessary to the development of the Framework. The workshop

was designed to be inclusive, participatory, and engaging, with each session sequentially building on the information presented and discussed in previous sessions. Participants discussed current knowledge of the impacts of offshore wind development to marine mammals and turtles; examined existing studies in Europe that have sought to measure such impacts; identified potential research questions and hypotheses; and reviewed potential analytical, statistical, and data-collection methods. Break-out groups, led by subject matter experts, discussed preliminary experimental designs for addressing the proposed research questions and hypotheses.

The generic research question is “Do wind farms cause a change in some parameter of interest for species of concern?” To generate more specific questions, researchers need to define the spatial and temporal scope and the parameters of interest. In terms of scope, one can measure temporal change (short-term or long-term, i.e., trend) over some defined area, or spatial change over some defined time, or both spatial and temporal change simultaneously. The potential parameters of interest include population size (stock abundance), relative population abundance (indices), occupancy, local spatial density/abundance, local spatial indices of abundance, movement (e.g., avoidance behavior of individuals), demographic parameters (e.g., birth, immigration, mortality), body condition/health, and/ or physiological/behavioral measures (e.g., stress hormones or changes in calling rates).

The hypotheses generated during the workshop fell into three categories. One, animals could be displaced from the wind energy area (by noise, construction, towers, etc.), two, animal behavior could change (e.g. calling rates, feeding, breathing, movements), and three, wind farms could alter habitat in a way that disrupts prey species availability for relevant whales or sea turtles. In all cases, it will be important to differentiate minor effects from those that will impact particular species at the population level.

Recent efforts to develop tools for detecting and measuring the population-level consequences of disturbance (PCoD) include a set of mathematical frameworks that can be used quantitatively to assess the magnitude of these effects. A key step was to include the concept of “health” (often quantified in terms of energy stores) as a way to link short-term effects of disturbance with long-term demographic outcomes on individuals. A number of case studies have been created, and work is ongoing to transition the methods to an operational context. In 2017, a further National Academies report was commissioned to review the wider context of the cumulative impact of multiple stressors. An expanded conceptual framework was developed, but implementing it in practice will be very difficult due to lack of knowledge on cumulative effects. This body of work is relevant to the marine renewable energy situation because installation and operation of wind farms may cause behavioral disturbance, potentially leading to population-level effects. Research studies should, therefore, be designed in such a way that they can help parameterize a PCoD model.

Other considerations for testing hypotheses include the ability to infer causation, whether a monitoring program should be adaptive (could it contribute to adaptive management?), and the features of successful, long-term monitoring programs.

There are several potential data-collection methods available for testing hypotheses. These include aerial surveys, remote sensors (e.g., infrared, radar, LIDAR), passive acoustic

monitoring including 1) archival methods (e.g. bottom-moored recorders, Slocum glider) and 2) real-time acoustic monitoring (moored buoy, Slocum glider, wave glider), tagging (implantable and/or suction cups), drones, hormones in scat and blow, and habitat monitoring/oceanographic sampling. The chosen monitoring program will need to be flexible; it will need to be able to incorporate new technologies that may come online. When choosing data-collection methods, additional considerations include species identification capacity, species of interest (Are you studying naturally loud or quiet species? Is this method appropriate for a whale or a sea turtle?), cost, data turnaround time (real-time or can you collect it after a period of time?), data-processing time, technology development stage (Is it ready to deploy or does it need more work?), geographic scale, detection range, limitations due to ocean and weather conditions, localization capacity ease of implementation, suitability for short-term or long-term studies, durability, and reliability of detections.

A summary of the group discussion of the potential research questions and hypotheses matrix and considerations for developing a research framework was discussed. Several points rose to the top. One, developing a research framework needs to be done in a regulatory context. In other words, data must be collected in a manner that can inform regulatory and management decisions on individual project review and long-term cumulative impacts. Two, the framework should be adaptable to new lease areas as they come online and other stressors emerge (e.g., fishing, climate change). Sequentially, each wind project up for review can then be placed in the context of all previous projects, better informing mitigation and development. Three, the framework should be designed to provide usable information about cumulative effects to decision-makers and so as to be able to respond to managers and regulators. Four, the information generated from the research framework should help regulators and developers determine the best timing for construction.

Finally, there is still much the scientific community has to learn about whale and sea turtle behavior and physiology; these gaps in knowledge will be a challenge when designing a long-term study. There are outstanding questions about how whales find food, how they navigate, migration routes, and the scope of their sensory capabilities. Regulators and industry should proceed with caution because these unknowns may be important for designing monitoring and research programs to determine the effects of wind utilities, and could have implications for the timing and magnitude of both construction and operations

1.0 Purpose and Context

1.1 Overview

The Massachusetts Clean Energy Center (MassCEC), the Massachusetts Executive Office of Energy and Environmental Affairs, the Bureau of Ocean Energy Management (BOEM), and the New England Aquarium (NEAq) convened a workshop on 30 and 31 May 2018 that included marine scientists (USA and UK), environmental NGO representatives, regulators, public stakeholders, and offshore wind leaseholders to inform the development of a scientific research framework (the “Framework”) to guide the long-term study of potential impacts to baleen whales and sea turtles associated with offshore wind facility construction and operation in the Northeast US.

The *Proceedings* seek to capture the key discussions, ideas, and questions raised by participants in the workshop. The *Proceedings* also serve to inform the research Framework being developed by the workshop’s technical Co-Chairs, Professor Len Thomas (CREEM), and Dr. Scott Kraus (NEAq). The workshop raised a number of questions that are captured, though not necessarily answered, in the *Proceedings*. Key questions, as identified by the participants, will help to inform the hypotheses to test in the research Framework.

Presentations from the workshop are available at the end of this document. Specific scientific citations can be found in the presentation slides.

1.2 Background

The baleen whales and sea turtles found off the Atlantic coast of the United States are migratory species that make use of the entire Atlantic Ocean for all aspects of their life history. Recent surveys of wind energy areas offshore of Massachusetts and Rhode Island have documented their presence in the area at various times of the year. In order to assess the ecological impacts of offshore wind facility construction and operation on these species in U.S. waters, a carefully designed research plan is needed. Because of multiple variables, including changing oceanic conditions, and inter-annual variability, any such research to determine effects will require careful experimental design, appropriate statistical methods, and data-collection methods designed to collect adequate sample sizes (Underwood, 1992).

1.3 Framework Scope and Application

The Framework will seek to increase understanding of potential population level impacts to baleen whales and sea turtles associated with offshore wind facility construction and operation at a regional scale over multiple years. Specifically, it will be developed and organized to answer the question: Do offshore wind facilities (construction and/or operations) affect the distribution, abundance, behavior, or demography of migratory and resident baleen whales and sea turtles?

As such, the Framework will not directly address construction and operation plans designed to mitigate potential impacts associated with short-term construction activities at the project-specific scale.

The Framework will be developed with a focus on assessing potential impacts to baleen whales and sea turtles associated with offshore wind facility construction and operation within the Massachusetts and Rhode/Island Massachusetts Wind Energy Areas (MA and RIMA WEAs,) since sufficient current biological data exist for this area and this is the area where offshore wind facility construction is anticipated to begin. However, it is anticipated that application of the Framework will be subsequently extended to address other offshore wind development along the Atlantic coast. The final framework will contain preliminary experimental designs that address research questions and hypotheses identified by participants during the workshop.

1.4 Workshop Purpose and Format

The goal of the workshop was to convene key stakeholders in order to elicit critical information necessary to the development of the Framework. The workshop was designed to be inclusive, participatory, and engaging, with each session sequentially building on the information presented and discussed in previous sessions. The workshop included both experts in various areas relevant to the subject at hand as well as policy managers and leaders from state and federal agencies, non-governmental advocates, and wind energy developers. Regarding the experts incited, the subject matter experts were assembled with specialties in such areas as aerial and acoustic survey methods, experimental design, statistical analysis, marine mammal feeding ecology, and endangered species management. These subject matter experts presented up to date research and current knowledge in their various specialties and provided expert input into the design of the research framework.

Participants discussed current knowledge of the impacts of offshore wind development to marine mammals and turtles; examined existing studies in Europe that have sought to measure such impacts; identified potential research questions and hypotheses; and reviewed potential analytical, statistical, and data collection methods. Break-out groups, led by subject matter experts, discussed preliminary experimental designs for addressing the proposed research questions and hypotheses.

1.5 Offshore Wind Developers' Perspective

Representatives from three offshore wind leaseholders presented brief overviews of their projects and their engagement on marine mammal research.

- Deepwater Wind (DWW) – Aileen Kenney, Senior Vice President of Development, emphasized DWW's efforts to plan proactively to minimize impacts through studying pile-driving practices at the Block Island Wind Farm, supporting the development of real-time monitoring tools, and interest in new monitoring techniques (e.g. passive acoustics, drones).
- Ørsted – Laura Morse, Environmental Manager, spoke about her company's support of innovative research on gliders and other technologies for real-time passive acoustic monitoring, methods to reduce gear entanglements, utilization of the Whale Alert application (<http://www.whalealert.org/>), and improvements in real-time monitoring via

protected species data collection software that can facilitate adaptive monitoring and mitigation.

- Vineyard Wind (VW) – Rachel Pachter, Vice President of Permitting Affairs, highlighted VW’s recent achievement of an 800-MW power purchase agreement with the State of Massachusetts, which will enable them to move forward on the first commercial-scale offshore wind project in the U.S. Part of VW’s winning bid was a \$3 million “wind and whales” fund intended to advance technologies and methods for reducing construction noise and improving whale detection.

1.6 Remarks by EEA Secretary Matthew Beaton

Executive Office of Energy and Environmental Affairs Secretary Matthew Beaton delivered remarks to the workshop participants. The Commonwealth of Massachusetts strives to develop renewable energy in an environmentally responsible manner. This goal is made possible by science-based decision-making, partnerships with diverse ocean users, and excellent intellectual capacity in the state. Secretary Beaton emphasized the importance of developing a strong marine mammal research program early in the offshore wind development process to ensure this industry minimizes its impacts on important populations such as the North Atlantic Right Whale (NARWs).

1.7 Regulatory Context

Dr. Desray Reeb (BOEM) presented an overview of the regulatory context for developing a marine mammal research framework. BOEM has a mandate to manage the development of the Outer Continental Shelf resources subject to environmental safeguards and a number of regulatory responsibilities under the National Environmental Policy Act (NEPA), the Endangered Species Act (ESA) and the Marine Mammal Protection Act (MMPA). BOEM carries out this mandate and its responsibilities for offshore renewable energy through its Office of Renewable Energy Programs (OREP). OREP reviews proposals for renewable energy development using a number of data sources including the regional ocean data portals, data collected through its Environmental Studies Program, and data synthesis workshops (e.g. 2017 Best Management Practices Workshop for Atlantic Offshore Renewable Energy Activities¹). Dr. Reeb also provided an update on the status of OREP’s leasing program including:

- The review status of various Site Assessment Plans and Construction and Operations Plans.
- Planning for new projects off the Carolinas and in the New York Bight.
- Management and incorporation of the results of completed and ongoing studies.
- State task force meetings.

¹ <https://www.boem.gov/BMP-Workshop-Protected-Species/>.

- Regulatory review and guidelines development.

1.8 Industry Context

Tyler Studds (MassCEC) provided a brief overview of the industry context regarding project installation. The following points were noted:

- The industry primarily uses two types of foundations: monopiles and jackets.
- Monopiles of various sizes, 2-10 meters in diameter (and getting bigger), are installed typically with impact hammers, driving the cylindrical welded metal sections into the sea bottom.
- The jacket foundations consist of three to four piles and a large jacket structure which provides a frame. The jacket structure is supported/secured by preinstalled driven piles (one per leg). Alternatively, the jacket is secured to the sea floor via piles which are driven through “sleeves” or guides mounted to the base of each leg of the jacket structure.
- There is some experience in using “suction buckets” to form vacuums to draw monopiles into looser or more malleable seabeds, but this does not work for all substrates.
- Gravity-based foundations can be used where the seabed is of sufficient uniformity.
- There are also floating foundations that can be used in waters generally too deep for monopiles (>60 m in depth). Current floating foundation designs include spar buoys, drag anchors, tension lines down to the seabed and concrete submersible platforms.
- In addition to turbines, substations have to be installed (usually requiring pile driving) in the array on some kind of platform, and transmission cable has to be laid between the array and a mainland transmission station.

2.0 Overview of Current Knowledge

The following section provides an overview of European studies on the effects and monitoring of wind facility construction and operation and ongoing MassCEC and BOEM large whale and sea turtle surveys in the MA and RIMA WEAs.

2.1 Summary of European studies on the effects and monitoring of wind facility construction and operation

2.1.1 Using acoustic methods

Dr. Dominic Tollit (SMRU Consulting Canada) presented a summary of European studies on the effects and monitoring of wind facility construction and operation using passive acoustic methods. Existing research frameworks for modeling the potential impacts of wind farm noise on populations (Population Consequences of Disturbance [PCoD] and Disturbance Effects of Noise on the Harbor Porpoise Population in the North Sea [DEPONS]) have a similar basic approach:

- Model spatial variation in animal distribution and received noise levels.
- Use noise exposure criteria to estimate the number of individuals disturbed.
- Estimate how disturbance or hearing damage affects an individual's reproductive probability or mortality risk.
- Apply these changes in a population model to explore longer-term trends in relation to baseline.

The DEPONS model² is used to predict impacts of anthropogenic disturbances on harbor porpoises. The model produces individual animal movements driven by food patches and predicts how behavior changes with the introduction of disturbance and how this manifests into population-level effects. PCoD is a conceptual framework that links individual-level behavioral disturbance due to anthropogenic noise to the aggregate effect of this disturbance on the individual's life functions and demography, and thereby to population-level effects.

Passive acoustic monitoring (PAM) techniques used in Europe during the wind farm construction period primarily focused on two species (harbor porpoises and bottlenose dolphins); there are no published long-term European studies of construction impacts on large whales (minke whales being the most abundant shelf species) mainly because it would be difficult to do these studies with any statistical power due to low whale densities in the construction areas. Thus current studies have focused on high-density species with a better chance to detect any potential change. The European studies collected data using static PAM—archival, static PAM—transmitting, and towed PAM. One type of static, archival PAM that is widely used is the C-POD (a relatively inexpensive data logger by Chelonia Ltd used to detect echolocation clicks of porpoises and dolphins). Three techniques not utilized extensively by European windfarms to date for monitoring studies on cetaceans: drifting PAM, animal-borne tags, and autonomous vehicles. However, these technologies may be

The presentation included a literature review of seven European studies that used Before and After Control Impact (BACI) or more recently gradient-monitoring designs to study temporal and spatial construction impacts on porpoises. These studies made use of porpoise click detectors (C-POD or T-POD). Overall, the studies had mixed results but all the larger studies found clear, short-term effects on porpoise acoustic activity in the construction area, with radii of effects reported 11-18 km from piling activities. Activity levels rebound following the end of piling, but not all studies report a return to baseline after years of post-construction monitoring. One study highlighted that construction effects were small when compared to natural variation.

² <http://depons.au.dk/>.

Best practices for collecting baseline PAM data indicate the need for at least 2 years of baseline data followed by data collection during construction and the first post-construction year and additional longitudinal studies. Gradient sampling and ground-truthing using visual observers are recommended and baseline data collection should look beyond impacts to a single species. Dr. Tollit also reviewed the strengths and weaknesses of utilizing static PAM, vessel-based PAM, and autonomous vehicles.

Workshop participants had the following comments and questions (*Responses are in italics*).

- **What studies associated with seismic surveys are being undertaken in Europe?** *Recent marine mammal studies have assessed responses to smaller arrays/single air guns. A range of seismic survey types is used across Europe.*
- **Did the studies show that porpoises habituated to the construction noise? Yes.** *One recent study in the Moray Firth showed the distance of detectable effects decreased from the first to the 86th piling. This was a short-term effect but without visual observers, it is hard to know if the initial effect was because the porpoises moved out of the area and then came back or if they simply quieted down. This highlights one critical limitation of many acoustic surveys: changes in detection rates of vocalization do not necessarily relate directly to changes in population distribution or density (because vocalization rates can change and because detectability of vocalizations can change over space or time or due to flow noise interference). The studies did find that pingers (i.e., active acoustic deterrents) were effective at excluding animals and are used as a mitigation tool prior to piling.*
- **Did the studies look at the efficacy of bubble curtains for mitigating noise? Where bubble curtains have been used, they have appeared to be very effective at reducing source levels. Although there is interest in how bubble curtains contribute to mitigation, this workshop is not focused on real-time mitigation.**

2.1.2 Using aerial and shipboard surveys

Dr. Kelly Macleod from the Joint Nature Conservation Committee (JNCC) presented a summary of European studies on the effects and monitoring of wind facility construction and operation using aerial and shipboard surveys. European regulators are increasingly interested in developing methods that are able to detect or accurately predict timely changes in marine mammal abundance – at local and population scales – to inform decision-making.

In Europe, aerial and shipboard surveys are primarily used for characterization surveys and studying the impacts of pile driving on harbor porpoises and bottlenose dolphins. The increasing size of offshore wind turbines and the associated safety risk to pilots and captains has seen a move from boat and aerial surveys (along with PAM) to aerial digital (i.e., high-resolution camera or video-based) surveys that fly at heights of 500 m, beyond the blade tip height. While the resolution of this method allows species identification, it is relatively costly and has yet to be able to provide estimates of availability bias (i.e., proportion of animals at the surface and so available for detection while in the surveyor's field of view). There are more

aerial survey efforts in the US and given animal tagging data and dive cycle information, we should be able to estimate and get at availability bias over time.

Much of the European research to date has focused on impacts to harbor porpoises during pile driving. Some aerial surveys have detected that during pile driving, porpoise densities were reduced at distances of up to 19 km (it's not known if mitigation such as bubble curtains were utilized during this study). At about 23 km, densities were higher than the baseline means, which demonstrated that animals tended to cluster around the edge of the disturbance footprint. The study also showed that it took only a few hours after the pile driving had ceased for densities within the impacted area to return to mean values. The results of other studies in Denmark and the UK that looked at changes in porpoise and seal distribution in response to pile driving have been generally consistent with these results, showing that animals are displaced from an area with a radius of around 20 km from the pile, with gradually fewer animals affected at greater distances from the pile.

In the UK, cetacean abundance estimates are only available at the UK scale (and wider European scale) from the decadal Small Cetacean Abundance in the European Atlantic and North Sea (SCANS) projects. JNCC completed a project called the Joint Cetacean Protocol (JCP³) to see whether smaller scale, disparate survey data from a variety of platforms (visual shipboard, visual and digital aerial) can be analyzed and modelled collectively to estimate population abundance and understand population trends. While the project results indicate that this method can increase spatial and temporal coverage, they come with many assumptions and are currently unlikely to be able to support rapid decision-making. Detecting population changes from abundance measurements in the short-term is challenging and a power analysis is essential to inform adequate survey design that will allow objectives around the detection of trends to be met. However, the predicted density surfaces from the project are being used in Environmental Impact Assessments to inform potential impacts of offshore wind construction within development areas.

Time-series data on vital rates (e.g., survival rates) will likely be an important means of detecting changes in an appropriate timescale. With the exception of seals and coastal bottlenose dolphins, however, researchers within Europe generally lack information on vital rates for harbor porpoise and other species. Dr. Macleod highlighted the DEPONS model where aerial and shipboard survey data are used to generate density surfaces of harbor porpoises and are integral to the population dynamics component of the model.

Workshop participants had the following comments and questions (*Responses are in italics*).

- **Is availability bias for digital aerial and regular aerial surveys different or the same?** *Availability bias is likely higher for digital aerial surveys as the survey area is in the camera/recorder's field of view for just an instant, while for regular aerial surveys the observer can see for somewhat longer (although the difference is not likely large). Availability bias is even lower for shipboard surveys, but then is harder to estimate because one needs to account for the pattern of animal surfacings rather than just the proportion of time on the surface. An additional issue with digital aerial surveys is*

³ <http://jncc.defra.gov.uk/page-5657>.

whether to record animals seen below the surface, because then availability calculations need to account for how far into the water the animals can be seen, which may vary over space and time.

- **The DEPONS project was funded by multiple developers. Can you talk about this funding mechanism?** *In the UK, regulators made it a condition of the consent that developers would have to make a financial contribution to the support the DEPONS research. This was deemed a more useful approach to understanding population level impacts than developers conducting small scale surveys of their site.*
- **Given the high post-processing costs of digital surveys, what work has been done with computer learning to reduce costs?** *This is being developed, but it has a long way to go. To keep costs low, some projects would only process about 10% of the images as a sample. While this may be an adequate sample to provide sufficient detections for analysis of seabird data, this would be unlikely to be adequate for lower density cetaceans.*
- **Cetacean data-collection by industry was not required during the second round of leasing given that regulators concluded enough had been learned through the first round of monitoring; only mitigation was required. Can you say more about this?** *There are mitigation guidelines (e.g., observers, PAM) that include real-time monitoring during pile driving; given sufficient studies from previous projects, regulators concluded that further data collection and study would not provide new or different information. Instead, resource was put into the DEPONS project to learn more about population level impacts of pile driving.*
- **What planning is happening in the U.S. for aerial surveys as the turbines become taller?** *The NYDEC/TetraTech visual surveys off of New York are already being flown at a height of 305 m, which should be above the future taller turbines. However, the Atlantic Marine Assessment Program for Protected Species (AMAPPS) surveys are flown at 183 m, which could be too low in the wind areas. To address this conflict Debra Palka from NMFS noted that they will be discussing the effects of various options which could include not flying in the WEA areas, flying higher in only these areas, or perhaps flying higher for the entire survey region using visual observers or using cameras*
- **Did the JCP results show distribution changes across the period of 1994–2010?** *The goal of the project was to detect changes in cetacean distribution and abundance but the challenge was to detect change using a wide range of datasets. The industry data JCP used are mostly post-2000; earlier data sets came from NGOs and other sources. The only species for which there were sufficient data to fit full spatio-temporal models of density (where the spatial surface can change over time) was harbor porpoise. For the porpoises, the distribution was estimated to have changed in that period.*

2.2 MassCEC/BOEM large whale and turtle surveys of the MA and RIMA Wind Energy Areas

Researchers briefed workshop participants on MassCEC and BOEM-funded large whale and turtle surveys conducted in the Massachusetts and Rhode Island/Massachusetts WEAs since 2011.⁴ These surveys utilized three different detection methods: aerial surveys, acoustic surveys, and prey sampling/oceanographic data (only in 2017–2018).

2.2.1 Aerial survey results

Dr. Ester Quintana (NEAQ) presented the results of aerial surveys in the MA and RIMA WEAs.

Research goals

- 2011-2015: Collect visual and acoustic baseline data on distribution, abundance, and temporal occurrence patterns of marine mammals, particularly endangered whales, and sea turtles.
- 2017-2018:
 - Collect additional visual baseline data on distribution, abundance, and temporal occurrence patterns of marine mammals, particularly endangered whales, and sea turtles.
 - Document the ecological factors contributing to the distribution, abundance, and timing of NARW occurrences in the WEAs.

Study design

Aerial data collection: researchers conducted 104 aerial surveys in 57 months in the MA and RIMA WEAs. Surveys were flown 1 or 2 days per month.

Results

1. Five species of baleen whales use the WEAs, including three endangered species (fin, sei, and NARWs).
2. NARWs were mostly sighted January to April, although low numbers were seen in some other months.
3. Other whales, including humpback, fin, minke and sei whales, were sighted mainly from April to August.
4. Lower numbers of whales were seen in the fall and early winter.

Additional data showed a high number of NARW sightings near the offshore end of the Muskeget Channel and NARWs tended to be found in waters ranging from 40 to 50 m in depth. The highest proportion of identified NARWs were adult males, although the current sex ratio of the population is male-biased.

⁴ Summarized in the Northeast Large Pelagic Survey Collaborative Aerial and Acoustic Surveys For Large Whales And Sea Turtles available at: <https://www.boem.gov/RI-MA-Whales-Turtles/>

Workshop participants had the following comments and questions (*Responses are in italics*)

- **Can you speak about results by individual: trends in months of habitat use and site fidelity?** *Our individual re-sighting rate is low and our sampling frequency is low (1 or 2 days/month). These two factors make it difficult for us to answer your question.*

2.2.2 Acoustic survey results

Dr. Aaron Rice (Cornell University) presented the results of acoustic surveys in the MA and RIMA WEAs.

Research goals

- Document occurrence of focal baleen whale species using PAM approaches.
- Quantify inter-annual variability.
- Identify spatial trends.
- Characterize ambient noise conditions.

Study design

The research team placed three recording units in the RIMA WEA and six units in the MA WEA. The research team used acoustic recorders to detect the specific sound patterns emitted by each species to identify which species were acoustically present in the study area. The study design did not allow the research team to collect localization data but they could roughly estimate the location of individual whales based on which recording unit picked up a call first (time-of-arrival analysis).

Results

1. Whale acoustic activity was detected in nearly all months of the year. Results showed clear seasonal trends in blue, humpback, minke, and NARWs and high interannual variability for humpback, minke, and NARWs.
2. NARW vocalizations were detected throughout the study area but were highest during spring, fall, and winter.
3. Ambient noise results showed this area to be significantly quieter than other areas in the Mid-Atlantic.

Workshop participants had the following comments and questions (*Responses are in italics*).

- **Detections can change for three reasons: (1) there are more animals, (2) they call more often, or (3) they are more detectable. There are three reasons why they might be more detectable: (1) they call louder, (2) the sound transmits better, or (3) there is less ambient noise. Can you say more about what is known about these and how you can infer behavioral changes?** *There has been some work done*

on loudness; you can do some calculations using the rate at which the whales emit calls and the detection range. These measurements cannot prove absence; it's really a presence/non-presence or presence-only survey design. I'm hesitant to make a statement about abundance using our findings. Scott Kraus has not finished processing his data but it shows good accordance between acoustic and sightings data.

- [Dr. Peter Corkeron, NMFS] We published a paper in 2010 about the relationship of NARWs observed in Cape Cod Bay and calls recorded. There was a relationship but we played down the relationship, however, because we didn't want to confuse readers; the uncertainty bounds are huge. But it's likely that whale presence and calls detected are related.
- **What kind of comparisons are you doing between acoustic and aerial data?** We have a concurrent survey with different methods so we will have an opportunity to test this relationship. The report summarizing the 2011–2015 data and two published papers are available. This relationship really depends on the species. We generally see NARWs when we hear them but humpbacks do not follow this pattern.
- **A challenge for the acoustic data is that NARWs are relatively silent during feeding aggregations.** This is definitely an issue that needs to be explored further.

2.2.3 Prey sampling/oceanographic data results

Dr. Mark Baumgartner from Woods Hole Oceanographic Institute (WHOI) presented the results of prey sampling surveys and oceanographic data collection in the MA and RIMA WEAs.

Research goal: Determine why NARWs visit the MA WEA. For most northern habitats, NARW movements are governed largely by food availability; does this hold true for the MA WEA?

Study design

The research team collected three types of data: zooplankton composition, zooplankton biomass, and oceanographic conditions. They sampled at standard stations and near feeding NARWs.

Results

1. NARWs feed on *Centropages typicus* and possibly amphipods in late winter and early spring, then transition to *Calanus finmarchicus* by mid-spring.
2. The source of *Calanus finmarchicus* is unknown but likely from the Gulf of Maine via the Nantucket Shoals.
3. The seasonal progression of zooplankton species is very similar to Cape Cod Bay.

Future work will include verifying the seasonal zooplankton pattern, characterizing the year-to-year changes in species assemblage and timing, determining *C. finmarchicus*' origin, and

determining if variations in *C. finmarchicus* abundance/timing will be related to changes taking place in the Gulf of Maine.

Workshop participants had the following comments and questions (*Responses are in italics*).

- **Are the *C. finmarchicus* results a recent development or have they just not been measured before?** *It's not known if this is new. There is historical sampling in this region from the annual MARMAP and EcoMON surveys, but it occurred only a few times a year and over a very large area (i.e., it used a very different sampling plan than the one we used). Our sampling was designed to be a weekly time series where/when whales occur in the MWEA, which is quite different to that used in the MARMAP/EcoMON surveys. Buoys allow us to look at circulation patterns to see what these can suggest about *C. finmarchicus* patterns. It is believed that these WEAs are at the southern end of *C. finmarchicus*' distribution but one would need to look at additional historical data. It's possible that whales may be feeding on different species of zooplankton.*
- **Long Island Sound sees large NARW aggregations. What prey data are available for this region? Rhode Island Sound has occasionally seen large NARW aggregations before. What prey data are available for this region?** *Very little useful data; the MARMAP/EcoMON zooplankton samples would not have been collected near right whales, which is really necessary to understand prey preferences. There was an opportunistic sample collected by URI or NMFS in 2010 that was full of *C. finmarchicus*, but the net was not calibrated.*

3.0 Developing Hypotheses and Experimental Design

3.1 Preliminary review of hypotheses and questions

In order to identify and capture all concerns and/or areas of inquiry regarding potential impacts to baleen whales and sea turtles associated with offshore wind facility construction and operation in the Northeast, all workshop participants were asked to write down potential research questions and hypotheses onto sticky notes and post them on a whiteboard. The workshop organizers then sorted these ideas into categories. The resulting matrix of hypotheses and research questions can be found in Appendix C. The ideas were placed into a matrix where columns included taxa such as:

- All species
- Marine mammals
- NARWs
- Sea turtles
- Zooplankton

Rows included parameters such as:

- Multi-scale/cumulative impact
- Population size
- Demography
- Health
 - Physiological
 - Energetic
- Response
 - Distribution
 - Movement and behavior related
 - Physiological
- Other

Collectively, these hypotheses and research questions will form the basis of the research framework. As a result, they were also the focus of subsequent discussion during the workshop.

3.2 Testing hypotheses

Professor Len Thomas (CREEM) presented an overview of potential analytical and statistical approaches to testing hypotheses. The generic research question that the group wants to answer is “Do wind farms cause a change in some parameter of interest for species of concern?” To generate more specific questions, researchers need to define the spatial and temporal scope and the parameters of interest. In terms of scope, one can measure temporal change (short-term or long-term, i.e., trend) over some defined area, or spatial change over some defined time, or both spatial and temporal change simultaneously.

Professor Thomas presented on the following potential parameters of interest and discussed each parameter’s data needs, analytical needs, and respective pros and cons:

- Population (stock abundance)
- Relative population abundance (indices)
- Occupancy
- Local spatial density/abundance
- Local spatial indices of abundance
- Movement (e.g., avoidance behavior of individuals)
- Demographic parameters (e.g., birth, immigration, mortality)
- Body condition/health
- Physiological/behavioral measures (e.g., stress hormones or changes in calling rates)

Professor Thomas reviewed recent efforts to develop tools for detecting and measuring the population-level consequences of disturbance (PCoD⁵). A 2005 National Academies report first addressed the issue of ocean noise, creating a conceptual framework linking individual-level behavioral disturbance due to anthropogenic noise to the aggregate effect of this disturbance on the individual’s life functions and demography, and thereby to population-level effects. The Office of Naval Research PCoD working group has turned this conceptual framework into a set of mathematical frameworks that can be used quantitatively to assess the magnitude of these effects. A key step was to include the concept of “health” (often quantified in terms of energy stores) as a way to link short-term effects of disturbance with long-term demographic outcomes on individuals. The PCoD group also further generalized the model to address all sources of disturbance, not just noise. A number of case studies have been created, and work is ongoing to transition the methods to a more operational context (rather than being limited to very resource-intensive, bespoke research projects). In 2017, a further National Academies

⁵ <http://www.smruconsulting.com/products-tools/pcod/>.

report was commissioned to review the wider context of the cumulative impact of multiple stressors. An expanded conceptual framework was developed, but implementing it in practice will be very difficult due to lack of knowledge on cumulative effects. This body of work is relevant to the marine renewable energy situation because installation and operation of wind farms may cause behavioral disturbance, potentially leading to population-level effects. Research studies should, therefore, be designed in such a way that they can help parameterize a PCoD model.

Other considerations for testing hypotheses include the ability to infer causation, whether this monitoring program should be adaptive (could it contribute to adaptive management?), and the features of successful, long-term monitoring programs.

3.3 Potential data collection methods

Dr. Scott Kraus (NEAq) presented an overview of potential data-collection methods for testing hypotheses. He discussed the advantages and disadvantages of each of the following methods, recognizing that the expertise for all methods was not necessarily present in the workshop.

- Aerial surveys
- Remote sensors (e.g., infrared, radar, LIDAR)
- Passive acoustic monitoring
 - Archival (bottom-moored recorders, Slocum glider)
 - Real-time (moored buoy, Slocum glider, wave glider)
- Tagging (implantable and/or suction cups)
- Drones
- Hormones in scat and blow
- Habitat monitoring/oceanographic sampling

Dr. Kraus emphasized that the chosen monitoring program will need to be flexible; it will need to be able to incorporate new technologies that may come online. When choosing data-collection methods, additional considerations should be discussed, including:

- Species identification capacity
- Species of interest (Are you studying naturally loud or quiet species? Is this method appropriate for a whale or a sea turtle?)
- Cost
- Desired data turnaround time (real-time or can you collect it after a period of time?)
- Data-processing time and cost

- Technology development stage (Is it ready to deploy or does it need more work?)
- Geographic scale of data desired
- Detection range
- Limitations due to ocean conditions
- Localization capacity
- Ease of implementation
- Desired temporal range of data, including suitability for short-term or long-term studies
- Deployment time range of instruments (e.g., five hours or five months)
- Durability
- Reliability of detections

Workshop participants had the following comments and questions, grouped by theme (*Responses are in italics.*).

- Participants recommended the following additions to list of data-collection methods to be considered for addressing research questions:
 - Environmental DNA (eDNA)
 - Drone photogrammetry (e.g., using small drones to get accurate estimates of whale size and how these data change over time)
 - Fixed blimp/balloon tethered over pile driver
 - Mark/recapture
 - Genetics
 - Aging of individuals via collagen base, age classes
 - Necropsy (for individuals thought to be affected by development activities)
 - Methods to monitor prey species (e.g., plankton counters, net tows)
 - Methods to monitor physical oceanography
- Other considerations
 - Consider which methods could be combined.
 - While eDNA is an exciting new technology, how would it contribute to answering the impact question? *It only indicates baseline presence.*
 - Consider simplifying the table by focusing on the output.
 - Vineyard Wind could dedicate some of its support funds to technology that needs a push to get over the threshold to operational. (For clarification purposes: the

- funds provided by VW will be appropriated based on the guidance provided from a panel of experts).
- These ideas will need to be tested against a benchmark in the future to see if those ideas were accurate. Could one do a peer review of this process? *We will add this as a recommendation.*
 - One could use existing structures and turbines to mount receivers. *The only downside of this approach is that this would bias the sample if turbines turn out to affect animal behavior.*
 - Caution should be exercised when looking at stress levels; it may be hard to attribute stress to a particular stressor.
 - The selected framework should be able to generate data on large and small marine mammals. One does not want to just study whales and then find out larger impacts on small marine mammals were missed.
 - The framework design should not lose sight of the regulatory policy need - the research needs to be able to satisfy regulators as to the “significance” of impacts as defined by the legislation, if plans are to be approved.
 - The research needs to help address and answer policy questions such as the “significance” of impacts in order to be practical and relevant to regulators.

3.4 Preliminary experimental design

A summary of the group discussion of the potential research questions and hypotheses matrix and considerations for developing a research framework, sorted by theme, is included below. Responses, when appropriate, are in italics.

Theme 1: Framework design, application and use

- **Framework in a regulatory context.** Data must be collected in a manner that can inform regulatory and management decisions on individual project review and long-term cumulative impacts. The exact manner in which the research conducted under this framework would inform regulatory and management decisions remains to be determined.
- **Framework design.** How could a framework be designed such that it could adapt as new lease areas come online and other stressors emerge (e.g., fishing, climate change)? As more projects are built, will each project up for review be placed in the context of all previous projects, potentially leading to a race to develop to avoid being the last in exceeding some cumulative impact threshold? If this happens, could the framework be designed to provide usable information about cumulative effects to decision-makers and could it respond at the pace development is happening?
- **Informing construction timing.** Can the information generated from this research program help regulators and developers determine the best timing for construction?

Developer Response: There are many time-of-year and weather-related restrictions developers have to work around. The costs of a project can increase significantly if developers miss a window to install pilings. It is most cost-effective for them to install in one season to minimize mobilization costs, and they may want to push later into the fall and winter if they want to complete installation. There are indirect impacts to animals, fishermen, and the navigation community if we take longer to install the piles than planned. In the 2017 best practices workshop, we talked about the best way to design seasonal restrictions to maintain flexibility (<https://www.boem.gov/Final-Summary-Report-for-BMP-Workshop-BOEM/>).

Theme 2: Study Design Considerations

- **Measuring sound levels.** Ability to measure sound levels at an individual animal level.
- **Migration patterns.** Acute and long-term displacement impacts:
 - What is the short-term gradient of the effect?
 - Are these WEAs on migration routes?
- **Cause of displacement.** If displacement is observed, can one determine if this is due to (a) animals being displaced by wind farm construction and operations or (b) changing oceanographic conditions?
- **Indirect impacts from displacement.** What indirect impacts from displacement from the WEA could fishing or navigation have on marine mammals (e.g., increased vessel strikes)?
- **Energetic health.** What level of energy are these animals gaining from feeding in the WEAs and what are the possible consequences of decreasing access to this energy source?
- **Dose and exposure time.** Is a concentrated dose of impact worse than a lower dose over a period of time?
- **Data deficiencies.** Frequency range of hearing and sensitivity of marine mammals and sea turtles
 - *This may not be useful information to collect because one cannot change their hearing range.*
 - *This information is important though in assessing possible impact to the species in question. Similarly calling behavior should be considered.*
 - *This data is valuable when determining exposure to noise. The NOAA technical guidance includes consideration for frequency range and sensitivity to that. This is so important that the Navy, oil and gas industry, BOEM and NMFS have dedicated millions of dollars to studies to improve our understanding of the frequency range of hearing and sensitivity of marine mammals.*

- *This information may be useful to predict range of noise effects.*

Theme 3: Cumulative impacts and determining contributions from different stressors

- **Measuring cumulative effect versus aggregate effect.** Multiple stressors of different types or sources produce cumulative effects. Each stressor has a different mode of action, which means they are challenging to put together to estimate cumulative effect. Aggregate effect – when the same stressor is applied multiple times (e.g., whales excluded from five wind farms) – is much easier to estimate. These definitions come from the National Academies 2017 report referred to above; other definitions exist so one needs to be clear in usage of these terms.
- **Power analysis.** Consider using a power analysis of different stressors to help design studies that can detect change due to different stressors. High natural variation (or indirect climate-induced change) in baleen whale density within the study area will inherently lead to lower power (and increased uncertainty) in any ability to detect change due to construction or operation of windfarms.
- **Addressing and planning for uncertainty.** With so much uncertainty, one may only be able to address some long-term issues when they start to happen. BOEM will try to be conservative in its initial approach and move forward accordingly as the research is produced. The best one can do right now is estimate the scale of the biggest stressors and try to address them: pile driving, vessel strikes, displacement of animals, early seismic surveys, and indirect stressors (e.g., whale and vessel interactions may change if both are displaced from areas they use).

Theme 4: Methods and data sources

- **PCoD framework.** PCoD models are an interesting way to think about problems (specifically, aggregate effects of pressures causing disturbance) but have any of them been ground-truthed? *No. Researchers are trying to make the PCoD work more operational. It has been mostly academic up to this point, but it is what has been most developed. There are not many other options yet available for empirical validation.*
- **Incorporating other datasets and data sources.**
 - *Could a model incorporate opportunistic data collected by Protected Species Operators (PSOs)? Potentially, yes, although consideration needs to be given to potential biases – for example, if operations are ongoing that affect local animal distribution or behavior. The JNCC JCP analysis mentioned by Dr. Macleod (see above) is an example of where some opportunistic (“platform of opportunity”) data were included in a spatio-temporal model of species density alongside designed line-transect surveys. Data quality can also be an issue. It may not be worth the time and money required to train PSOs. It is a good conversation to have, however, PSO programs are already funded and their instructions are fairly standardized due to permit requirements and agency guidance documents.*

- Could stranding network data be better utilized as an opportunistic source of data – for example might there be spatial or temporal patterns in the reported strandings that will coincide with wind farm development? *This is unlikely. Stranding network members are not funded sufficiently to conduct necropsies of every stranding, which would be necessary to develop a sufficiently large and unbiased sample.*
- **Role of historic data.** What role could historic data play in designing a study? *One would first need to work out the effect size to examine and the questions to answer. This would require looking at other sources of variability, namely baseline information including historic data.*
- **Methods for measuring stress.**
 - Could thermal cameras give us data on stress levels?
 - If one wants to measure stress in a small population (e.g., NARWs), is there a way to detect effects in a more abundant species and use them as proxies? *Or would these impacts be species-specific? Since this is the beginning of the process, one could try starting with other species and then working with NARWs if needed. One limitation on this approach is that one needs the proxy species to occur in the same areas as the target species.*
 - What are the challenges and limitations of using biopsy and baleen samples for hormone analysis? *The time of transfer of hormones into the skin is not well understood. Some animals have faster skin turnover and some have seasonal changes. Repeat sampling would be needed from the same animal to complete the dataset.*
- **Measuring different scales of movement.** BOEM's movement model in the Vineyard Wind EIS is based on short-term observed movement datasets but there are additional scales to consider: long-term movements like migration and intermediate movements like foraging. One needs to consider how much energy is being expended at these different scales. What is avoidance costing them? *The PCoD and DEPONS models are trying to do this kind of analysis.*
- **Matching methods to construction techniques.** How might one design a monitoring program for different construction methods that may be employed (e.g., monopile driving, jacket foundation, gravity foundation, suction buckets).
- **Reducing risk.** Concerns were raised about risking additional health declines of endangered species as a consequence of the research activities. Less risky methods should be favored.
- **Energetic models.** It would be possible to build a spatially explicit energetic model but data would need to be collected now on the parameters that primarily drive those models. These data could be mitigation-driven; they could help choose the best timing

and location for construction. One would still need to monitor the core demographic parameters (e.g., calf numbers, survival of adult females).

Theme 5: Considerations for choosing an experimental design

- **What is the goal?**
 - A model that will work for one species or a range of species?
 - A model that can answer the largest number of the questions desired or a model that answers priority questions?
- **Complexity level.** Is a unifying framework necessary to answer some initial questions or is there a simpler approach to start with? *There are relatively straightforward data to collect to answer some questions, but why do it if there is not a framework to place the data into? One might as well start with one because someone will ask, “to what end were those data collected?”*
- **Cost.** Should the design be cost-effective? Should one consider the resource balance between mitigation and research efforts?
- **Phasing.** How to parse the phases of wind development and monitoring (e.g., pile-driving impacts, vessel strike impacts)?
- **Planning for decommissioning.** How should any approach take into account decommissioning? *The impacts would likely depend on the removal technique. The oil and gas industry, for example, has used explosives and other cutting techniques in the Gulf of Mexico. A developer would provide their decommissioning plan (for example, proposed removal techniques) in their Construction and Operation Plan. More specific details will be provided in their stand-alone decommissioning plan, as decommissioning approaches.*

Theme 6: Appropriate scale

- The scale of the research question is critically important. Population impacts are likely more important to study than short-term individual impacts.
- It was also noted, however, that short-term responses may be informative and relevant to management decisions (i.e., regulators often have to base decisions on known and short-term measured impacts while assessing the quality and effects of their decisions through longer-term monitoring)

Theme 7: Baseline characterization

- The RI and MA WEAs have good baseline data. How can one determine if this characterization was done correctly?
- Are good baseline data available elsewhere (e.g., New York Bight?)

- The baseline data may need to be refined based on where certain marine mammals occur outside of known hot spots.

4.0 Testing Effects of Construction Hypotheses – Short-term

4.1 Current understanding of potential short-term construction impacts

Dr. Desray Reeb (BOEM) reviewed the current understanding of short-term construction impacts. Dr. Reeb identified the need for the framework to provide guidance to ensure that the ultimate experimental designs will provide BOEM and NMFS with data that the agencies can use to evaluate the potential effects of construction activities on listed and proposed species, as well as designated and proposed critical habitat. The agencies currently make use of the best available science to complete these assessments and respond to stakeholder questions, however empirical data in the Atlantic are currently lacking in this regard. Studies in Europe found that harbor porpoises show varied levels of short-term displacement during construction activities while gray and harbor seals demonstrated post-construction use of turbine areas for foraging. The challenge of this proposed framework is to determine:

- What are the short-term impacts (positive/negative) from pile driving on baleen whales and sea turtles?
- What significance will any short-term impacts have on baleen whale and sea turtle populations?
- Can short-term impacts be measured? If so, how?

Dr. Reeb highlighted the need for improved baseline data (e.g., ambient noise levels), better characterization of noise sources, better understanding of the responses of marine mammals to pile driving, and data to facilitate utilization/validation of the PCoD model. She also asked the group to identify other data or issues researchers should examine.

Chris McGuire (The Nature Conservancy) noted that the group should be deliberate about its word choice, specifically the terms “effect” and “impact” that are often used interchangeably: “effect” is a change one can observe while “impact” is the magnitude of a change that one deems important. For example, an eel slowing down for a few minutes of its 1000-mile migration as it crosses underwater cables may not be impactful. Other participants agreed that though these terms have been used interchangeably, this distinction is important.

4.2 General categories of short-term impact research

Workshop participants provided feedback on a draft outline of a research framework to assess potential short-term impacts. This framework was assembled based on the potential research questions and hypotheses identified by participants (see Appendix D). Feedback is grouped by section:

4.2.1 Species to study

NARW (assume no pile driving will be occurring when NARWs are present)

- The seasonal occurrence of any species of interest needs to be taken into consideration. In the context of the MA and RI WEAs, the NARW is an example. There is only a very small window in July when NARWs were not acoustically detected by previous survey efforts so finding a time when all NARWs are not present will be difficult, if not impossible to meet. However, this type of seasonal restriction would focus on the potential for higher densities/occurrences of NARWs. The visual surveys did show much lower presence in August through early winter.

Other baleen whale species

- Ultimately, the list of study species may depend on the method(s) chosen.
 - Fin whales sometimes have so many vocalizations their calls overlap so one cannot separate them. Vocalizations can also be detected from long ranges making it difficult to assess changes in use of a small area.
 - There is an unusual mortality event for minke and humpback whales occurring right now. One may need to consider the risks and confounding stressors when selecting species to study.
 - Sei whales are difficult to tag because one has little warning when they surface.
- This list needs to take into account the fact that the distribution of species will differ between WEAs. One should consider where piling will occur and choose species based on that locality, even if they can be detected acoustically. Other approaches include choosing a study area based on where the target species occurs and choosing a target species based on the questions one wants to answer.
- What about species and study areas in the Mid-Atlantic if construction activities appear to be moving faster in that region? Vineyard Wind is aiming for 2020 but there may be some experimental pile driving off Maryland before then.

Though the focus of much of the conversation was on baleen whales, the group also mentioned other species commonly found in the MA and RI WEAs, including turtles and pinnipeds. Other possible species could include sperm whales, that are still listed as endangered. Harbor porpoises are not delphinids, but are the only cetacean where we have data from Europe and they do seem to be sensitive to noise. And Ziphiids are present, though they may be rare, and also are known to be noise-sensitive.

Turtles

- Satellite tags work well for turtles, although hard-shelled species are easier to tag.
- Certain species of turtle are easier to identify than others (e.g., leatherbacks are easier than loggerheads).

- One should consider how to adapt the program if pile driving changes the pattern of availability of turtles.
- One expects to see turtles near turbines because of the new habitat created.
- There is some concern with entanglement due to charter boats and recreational fishing gear expanding near the turbines due to reef effects enhancing fish abundance.

Pinnipeds

- Many though not all pinniped populations are growing right now so they are a lower conservation priority. It is likely that only a small percentage of the population will be affected by construction activities.
- One expects to see pinnipeds near turbines because of the new habitat created.
- There is some concern with entanglement due to charter boats and recreational fishing gear expanding near the turbines due to reef effects enhancing fish abundance.
- The Marine Mammal Protection Act says one has to consider pinnipeds so they should be included in deliberations.

Fish

- No comments.

4.2.2 Scientific hypotheses

The draft outline of the research framework listed four proposed hypotheses. Workshop participant feedback on these hypotheses is noted below the corresponding hypothesis. *Responses are in italics.*

Hypothesis 1: Individuals of [species] are displaced over [distance] from pile-driving activities for [time period].

- This hypothesis incorporates energetics data.
- This hypothesis incorporates calling rate data.

Hypothesis 2: Individuals of [species] cease feeding over [distance] for [time].

- This hypothesis incorporates energetics data.
- This hypothesis incorporates calling rate data.
- Feeding behavior on the surface versus subsurface will determine methods.
- Links to Hypothesis 4. Should these be combined? *Animals may cease feeding for different reasons (e.g., aversion to noise) so they are probably separate.*

Hypothesis 3: Individuals of [species] show elevated [stress hormone] over [distance] for [time].

- This hypothesis incorporates energetics data and incorporates calling rate data.
- Are there other proxies of stress that can be collected?
- Is there more one can study beyond hormonal changes to get at stress levels (e.g., behavioral changes like the species surfacing more often)? *One would need to identify which behavioral responses one is interested in.*
- Are there baseline data on stress hormones in these species? If not, how long would it take to establish? *There are probably only good baseline data on humpbacks and possibly North Atlantic Right Whales right now. To get these data for a different species, one would likely need 25–50 samples. These would probably take a year to collect.*

Hypothesis 4: Zooplankton prey change their vertical distribution or density or patch structure over [distance] for [time].

- Should one only look at zooplankton or should we also look at herring and other fish?
- What anti-fouling treatments for turbines will be used and could they have an impact on zooplankton? *It's highly unlikely that companies will use biofouling treatment on the piles because they will not be able to reapply the paint underwater after it wears off. The data from Cape Wind's met tower have not shown any known impacts, but plankton was not monitored. BOEM's RODEO program at the Block Island Wind Farm is studying the biotic community attached to the foundations. BOEM has seen a lot of mussels attaching to structures and thriving, but the study is not collecting zooplankton.*
- Could there be water temperature changes due to turbine operations that could impact zooplankton? *The flow direction of water is interesting and has anyone looked at this? It would be highly unlikely that turbines would warm or cool the water significantly due to the high heat capacity of water and the volume of water involved. Wind over water is a greater force for heat exchange than a few turbines. There are microclimate impacts in the air for onshore turbines and this effect can extend for a few dozen meters, but this effect would not be very strong in the ocean. If there is an electromagnetic current running through the field, there may be some disruption of the thermocline but that is likely to be insignificant.*

4.2.3 Study designs to address hypotheses – small group discussions

Workshop participants were divided into small groups and asked to design a study for short-term impacts. They were also asked to note important considerations to keep in mind as the study is designed and set up. *Responses, where appropriate, are in italics.*

General feedback

- Use proven technology.
- Vineyard Wind is planning to use certain monitoring methods, including passive acoustics, during pile driving. One might consider using complementary methods in this study. Europe has had issues comparing projects because there was no standardized monitoring program. It is critical that one does not make the same mistake here.
- Is the first installation to be used as a pilot experiment where one can test proposed methods? Or should the full program be ready to go when the first installation happens?
- What lessons can be learned from monitoring during pile driving at the Block Island wind farm? *BOEM did sound monitoring but we are still analyzing these data and hope to release them by the end of 2018. The windfarm's piles were driven in at an angle so there may be different sound patterns compared to vertical piles. We also looked at seafloor disturbance, particle motion, and how long driving takes. The first RODEO report ([https://espis.boem.gov/Final Reports/BOEM 2018-029.pdf](https://espis.boem.gov/Final%20Reports/BOEM%202018-029.pdf)) will come out in the next month. Deepwater Wind's protected species observations don't go into a public document but they have the PSO data. These data need to be compiled, but they can be made available. Deepwater Wind is also using a data-collection app more frequently. Ørsted provides summary PSO reports to NMFS and BOEM for site investigation surveys. These data can be made available. Several of our surveys use Mysticetus, a data collection app.*
- It may be important to be able to collect data without having humans on the water.

Passive acoustic studies

- Most currently workable hypotheses: H1, maybe H2.
- Possible parameters to measure: presence/non-presence, call type and rates, call frequency, call volume, movement. Some parameters may require localization abilities.
- Experimental design specs
 - Baseline data: 1 year or do a few months sampling prior to construction if current baseline is considered sufficient.
 - Could create a design that covers a visual survey area: within windfarm, use a gridded design to study local movement. Use multiple spokes outside the farm deployed using an increasing gradient design (ideally to the 120 dB isopleth or beyond predicted effect distance). Look at grid design on NMFS/Shell research effort in the Chukchi Sea for lessons learned. An 8 km grid was proposed by Dr. Rice.
 - Explore using short-term equipment deployments during pile driving.

- A cabled array is preferred but may be too costly. Bottom-moored archival units are likely best.
- Design grid spacing for whales – fin and sei.
- Equipment requirements: broadband, continuous, long-term. Ability to detect all cetacean vocalizations. Dr. Van Parijs suggested a mix of low sampling rate devices with some broadband high sampling rate units might be most cost-effective.
- Experimental Design considerations
 - May need to combine PAM with other methods; could study a wider range of impacts if PAM is coupled with aerial surveys.
 - Design should also be appropriate for long-term studies.
 - Design should work with developer's data-collection efforts.
 - Need to consider how to address data gaps when piling noise masks some calls.
 - Power analysis would inform grid design.
 - Bear in mind loss of PAM data due to trawling activity or unit failure.
 - Important to consider data storage and accessibility.
 - Should the design be able to localize calls and track animals? Real-time buoys may be useful during construction to add to sensor network during aerial surveys or to define limits of PAM monitoring.
 - Data collection at least 1 year post construction.

Visual survey

- Most currently workable hypothesis: H1 is well suited.
 - Could possibly help with questions about stress behavior and prey changes.
 - Interest in knowing if animals are avoiding pile driving, what behavior patterns they exhibit, and how long those patterns are exhibited.
 - Turbine heights may impact visual survey heights in and near the turbines (one mitigation to this challenge are smaller drone surveys or surveillance on the turbines themselves).
- Experimental Design specs
 - Multispecies survey but summer occurrence would dictate the list.
 - Stratified survey: area around pile driving activity would have higher density transects, lower density farther out.
 - Suggested activity area: the survey area would ideally include both the area of potential effect (e.g., the space within which the sound can be heard) as well as

"control" areas outside the potential area of effect. Without knowing the area of potential effect it is hard to define the survey area to target, but the survey area would be inclusive of both noisy and non-noisy areas. Maybe RODEO work could inform this.

- Temporal coverage: conduct surveys before, during, and after. Consider surveying throughout the construction season. Baseline data can inform sample sizes.
- Keep observers blind to pile-driving schedule to reduce bias.
- Focal follows from ships would be helpful to look at individual responses.
- Experimental Design considerations
 - Power analysis of the baseline data could help determine best design specifications.
 - Aerial surveys are better than shipboard surveys for H1 because they have a quicker response and larger range.
 - Question of how to use PSO data to record behavioral data, if at all. Concern about quality control.
 - Consider concurrently collecting data on zooplankton blooms (?) and fish 'bait balls' during flights.
 - Could visual aerial surveys be used to study stress behaviors despite the added complexity?

Pseudo-experimental exposure (PEE) studies (stress response, movement response)

- PEE is a term coined to reflect the idea that there is not a designed experiment, with randomization, but one can still apply concepts from experimental design in making inferences, within limitations.
- General takeaway: Conceptually this could be done, but logistics may diminish the work's value.
- Experimental Design specs
 - Short-term behavioral response studies.
 - Have a control and assessment area; monitor each area before, during, and after pile driving. Monitor for at least three years.
 - Focus on finbacks, humpbacks, seis.
 - Consider coordinating with an acoustic network.
 - Mixed feedback on which tags to use.
 - Should they be able to collect data about sound exposure or not, or can you extrapolate this from other data? Limpet tags are easiest and fastest,

and the technology is almost ready to allow limpet tags to collect noise exposure for a period of 7 days.

- Could tag animals with D-tags a day or two before pile driving so can collect data on the individual behavior immediately prior to pile starting. May be work that will not yield useful data if the tagged individuals leave the area before driving starts.
 - Statistics would help determine how many animals to tag.
- Experimental Design considerations
 - Given the heterogeneity of the coast, it may be difficult to find an appropriate, simultaneous control area with the species to be studied.
 - This would be during construction, not experimental sound playbacks.
 - Whales react differently if they are feeding or migrating, so one may want to assess the prey environment.
 - No one yet has conducted a study making use of a production-level seismic air gun array; only scaled up projects have been conducted. One probably cannot do a pile-driving scale-up.
 - Aaron Rice (Cornell Univ.) has submitted a proposal to acoustically monitor around the met tower installation in Maryland waters but it will be installed at a time with low whale presence. This could be an opportunity to test methods on an installation, regardless of the data produced.
 - A meta-analysis could show effect even if each study isn't perfect.
 - What would one miss if this isn't studied? Probably behavioral response answers. Other studies wouldn't cover the potential changes in acoustic characteristics so it may be worth doing.

Prey field study

- Refined research questions and selection criteria
 - Do construction activities have impacts on zooplankton aggregation?
 - Do construction activities have mortality impacts on zooplankton? Would these impacts have a measurable impact at the zooplankton population level to impact NARWs?
 - Do construction activities impact NARW prey capture and feeding? Can these impacts be detected?
 - Do offshore wind project operations affect zooplankton abundance? (General consensus is no).
 - Proposed criteria to dismiss a hypothesis/research question:

- Too hard/impossible to answer or intractable (likely for many of the proposed hypotheses).
 - Data not available.
 - Too expensive.
 - Collective wisdom says no significant impact will be found.
- Experimental Design specs
 - Consider using active acoustics and video recorders, not just sampling.
 - The challenge is the only way to find masses of zooplankton is by first finding feeding whales, hence, without whales that may be driven away by noise one cannot find the aggregation of zooplankton to measure.
- Experimental Design considerations
 - What can one learn from seismic studies and apply to this study?
 - Should try to measure impacts to zooplankton close to pile driving.
 - A fisheries group has chosen to prioritize collecting baseline zooplankton data. We should make sure any work that comes out of this workshop is aligned with that effort.
 - Need further discussion about monitoring forage fish impacts.

5.0 Testing Effects of Construction Hypotheses – Long-term

5.1 Current understanding of long-term construction impacts

Kyle Baker (BOEM) reviewed the current understanding of long-term construction impacts. There is a lot of uncertainty in the regulatory and scientific communities around how to measure and assess long-term impacts. The concept of threshold impacts is also of interest right now. Currently, there is no regulatory definition of a long-term impact. The scientific community does have baseline information on many species and habitat types and has observed effects during construction activities for some species, for example, studies of harbor porpoise in Europe. Unfortunately, there is still missing information, many stressors and/or effects require more study, and it is unclear if surrogate species can be used to study species of concern. There may also be unknown and therefore unstudied impacts.

Workshop participants should consider which long-term effects this research framework should address. Mr. Baker briefly reviewed current understanding of the following effects:

- Foundations
 - Habitat alteration
 - Reef effect
- Vessel traffic (changes in patterns and potentially increased strikes)
- Cables and electromagnetic fields
- Turbine noise during operation
- Pile driving

Mr. Baker also reviewed potential variables and indicators to study (e.g., ambient noise levels, sea temperatures) and actors (e.g., developers and relevant state entities) that should be considered as a monitoring program is set up.

Scott Kraus (NEAq) emphasized how much the scientific community still has to learn about whale behavior and physiology; this knowledge gap will be a challenge when designing a long-term study. There are outstanding questions about how whales find food, what they can hear, how they navigate, and the scope of their sensory capabilities. Regulators and industry should proceed with caution because these unknowns become important when large-scale construction begins.

5.2 General categories of long-term potential impact research

Workshop participants provided feedback on a draft outline of a research framework (see Appendix E). Feedback is grouped by section:

5.2.1 Species

- Propose excluding NARW tagging from the study to reduce risk to individuals and a population already in decline. Previous long-term tagging projects have not produced sufficient new information and current tagging efforts have been limited.
- Note on Tagging from Commenter: Implantable tagging does provide real time high resolution detail on individual movements on a scale of weeks and months which is relevant for consideration of activities over similar time frames. Long term tagging has been utilized to define and expand critical habitat, determine in greater detail migratory patterns and elucidate responses to anthropogenic activity. Implantable tagging is a critical tool that should not be dismissed.
- Consider using species with comparatively more robust populations (e.g., humpbacks) as proxies to learn about potential impacts to NARWs.

5.2.2 Scientific hypotheses

Hypothesis 1: Wind farm existence/operation has an effect on local spatial density of [species] in the vicinity of wind farm [be explicit about distance].

Hypothesis 2: Wind farm existence/operation has an effect on migration of NARWs.

- This is important to ask but how would it address multiple projects developing over time, along the coast? The PCoD framework can help frame the issues. One can model the migration changes if it is assumed animals avoid offshore wind projects. It is unlikely they would stop migrating altogether, particularly mothers and calves. Tagging of bowheads was done in part to address this question. While in the bowhead's case it was long duration tags, medium duration tags could accomplish the same but with far less impact to an individual

Additional hypotheses and research avenues

- Add a hypothesis about indirect impacts, for example, the potential for entanglements due to trawl gear being displaced and pot gear replacing it; or; whales are excluded from offshore wind farms forcing them into navigation corridors resulting in increased vessel strikes.
 - This should be included in the study; ESA requires NMFS to consider all knowable effects of a project, including indirect effects. One can model certain indirect effects.
- Add a hypothesis about positive impacts: Consider whether this research effort should also measure and track any long-term, positive effects of wind development on the environment (e.g., carbon reduction, localized habitat creation).
- Add a physiological/energetic hypothesis: Wind farm existence/operation has a long-term effect on health and calving of NARWs.

- Consider studying turtle migration impacts: turtles use electromagnetic fields during migrations.

Considerations

- It may be difficult to attribute causation when using proxy sites.
- Need to differentiate climate impacts from wind farm impacts which will be challenging.

5.2.3 Experimental designs to address hypotheses – small group discussions

General feedback

- The experimental study design should take into account and be able to provide information on rapidly shifting baselines.
- Can one apply the PCoD framework to entanglement data to help address some uncertainties?
- A metadata analysis may be able to answer questions and eliminate the need to implement an active tagging program. Consider other areas where a metadata analysis could be useful.

Passive acoustic studies

- Experimental Design specifications
 - Scaled down grid array within and outside farm beyond the short-term impact studies. Should be adaptable depending on initial post-construction results.
 - May need to pair PAM and visual surveys. Buoys and gliders could help track migration patterns but visual surveys and tagging may be a better tool to study migration effects.
 - Set up arrays in multiple farms.

Visual aerial survey

- Experimental Design specifications
 - Monthly aerial surveys.
 - Replicate across farms and standardize methods.
 - Could pair with PAM: real-time arrays could send alerts of NARW presence and planes could be deployed to go find them. May be logistically complex.
 - Photo identification may be useful for studying displacement of small populations.
 - AMAPPS is helpful; should keep doing these surveys at least annually and ideally four times per year. Power analysis should be carried out to inform optimum frequency.
- Experimental Design considerations
 - If studying large-scale displacement, will need to monitor the waters outside the wind farm.

PEE studies (stress response, movement response)

- Experimental Design specs
 - Need a control site (e.g., Cape Cod Bay for NARW). Potentially could be a site prior to pile driving.
 - Should be a multiple species experiment – fin, sei, and humpback whales.
 - Collection techniques
 - D-tags, limpet tags, blow samples, biopsy, drones.
 - Collect equivalent oceanographic information at both the control and test site.
 - Collect received-level data using tags or gliders.
 - Supplementary data collection: biopsies, hormone work.
 - Experimental design
 - Numerous animals tagged the day before pile driving. Limitation: tags have a 3-day (or less) life. Smart tags in development by Russ Andrews and others have a 1-week duration, which makes success of experiment greater.
 - Tag within 10 km of sound source.
 - Conduct tagging the year before, during the pile driving, and year after (should be in the same season).
 - Consider DMONs and gliders.
 - Combine with photo identification studies.
 - Need ancillary oceanographic information (e.g., temperature, plankton).

- Experimental Design considerations
 - Hard to tell if animals avoid areas or are attracted to areas. Given current technology, tagging enough animals may seem difficult. However, Brandon Southhall has led many Behavioral Response Studies. These studies were completed without high levels of tagging. A thorough review of BRS studies could be completed.
 - Must capture response of whales during the first pile-driving event, before they begin to habituate.

6.0 Outstanding Questions

At the end of the workshop, a number of outstanding questions remained:

- Is the current baseline we might collect now or soon sufficient and appropriate given changing environmental conditions over time?
- How can baseline data be increased in other regions and areas along the coast?
- How can one better synthesize and standardize diverse data sources and datasets?
- What are gaps in what is known?
- What should the relationship between this research framework and regulatory decision-making be, and will likely be because of the MMPA/ESA authorization process?
- What metadata analyses would be relatively easy to do and useful to agencies? (Proposed metadata analyses include the effect of impulsive and continuous sound sources on all taxa, aerial surveys of the WEAs, and tagging data.)
- Any telemetry studies should consult with or include organizations and individuals with turtle tagging experience and those associated with the Integrated Ocean Observing System's Animal Telemetry Network.⁶
- How would industry funds be best spent? How would regulators determine the appropriate allocations? With constrained resources, mitigation and prevention versus monitoring expenditure will have to be decided upon.

⁶ <https://ioos.noaa.gov/project/atn/>.

Appendix A: Final Agenda

9:00	Welcome and Introductions	
Purpose and Context		
9:10	Offshore Wind Marine Mammal Research Framework: Purpose and Scope	MassCEC
9:20	Offshore Wind Developers Perspective	TBD
9:30	The role of this workshop in developing the Offshore Wind Marine Mammal Research Framework	Co-Chairs
9:40	Regulatory Context: BOEM's role and current offshore wind project development projections	Desray Reeb, BOEM
9:50	Workshop Design and Participation Ground Rules	Patrick Field, CBI
Overview of Current Knowledge		
10:00	Summary of European Studies on the Effects and Monitoring of Wind Facility Construction and Operation Using Acoustic Methods	Dom Tollit, SMRU Consulting
10:15	Summary of European Studies on the Effects of Wind Facility Construction and Operation Using Aerial and Shipboard Surveys	Kelly Macleod, UK Joint Nature Conservation Committee
10:30	<p>MassCEC/BOEM Large Whale and Turtle Surveys of the Massachusetts and Rhode Island Massachusetts Wind Energy Areas</p> <ul style="list-style-type: none"> ● Aerial Survey Results ● Acoustic Survey Results ● Prey Sampling/Oceanographic Data Results 	E. Quintana, NEAq A. Rice, Cornell M. Baumgartner, WHOI
11:00	BREAK	
Developing Hypotheses and Experimental Design		
11:30	Introduction: What is a useful hypothesis or question?	Co-chairs
11:40	<p>Generating Potential Research Questions and Hypotheses</p> <p>Workshop participants write down potential research questions and hypotheses and post them for viewing to enable all participants to understand the range of concerns and potential research topics.</p>	All
11:55	<p>Preliminary Review of Hypotheses/Questions</p> <p>Co-chairs review and discuss the research questions and hypotheses with the group, seeking clarification where necessary, and begin to group them into general areas of inquiry/interest.</p>	Co-chairs

12:15	LUNCH	
1:15	Detailed Review of Categorized Research Questions and Hypotheses	Co-chairs
1:45	Overview and discussion of potential analytical and statistical approaches for testing hypotheses including strengths, weaknesses and data requirements	Len Thomas, University of St. Andrews
2:30	BREAK	
2:45	Overview and discussion of potential data collection methods for testing hypotheses including aerial surveys, passive acoustic monitoring, oceanographic sampling for prey and environmental conditions, gliders (AUVs with real-time reporting), drones, night vision technology, hyperspectral detection, radar, active acoustics) satellite and radio tagging.	S. Kraus, NEAq M. Baumgartner, WHOI
3:45	Preliminary Experimental Design: Discussion to begin connecting hypotheses, analytical/statistical methods, and data collection methods	Co-chairs
4:45	Final general discussion and reflections on day, Overview of Day 2	Co-Chairs, BOEM, MassCEC
5:00	ADJOURN	

9:00	Review and Synthesis of Day 1	Co-chairs
Testing Effects of Construction Hypotheses - Short-Term		
9:15	What is our current understanding of short-term construction impacts? Review definition, purpose, scale/scope, and key actors for assessing short-term impacts on whales, dolphins and sea turtles.	Desray Reeb, BOEM
9:30	<p>Discussion of general categories of impact research and connections to hypotheses developed on Day 1</p> <ul style="list-style-type: none"> ● Distribution and abundance vs. baseline ● Acoustic signals (changes in rates, frequency) ● Physiological measures (health, stress, respiration) ● Movements, behavior changes <p>These discussions will use input from Day 1 on priority hypotheses or questions; research design; methods of monitoring; analytical methods.</p>	Discussion facilitated by Co-chairs, CBI
10:15	Stakeholder questions/discussion: Short-term impact research	Discussion facilitated by Co-chairs, CBI
10:30	BREAK	
10:45	Stakeholder questions/discussion: Short-term impact research, cont.	Discussion facilitated by Co-chairs, CBI
12:00	LUNCH	
Testing Effects of Construction Hypotheses - Long-Term		
1:00	What is our current understanding of long-term construction impacts? Review definition, purpose, scale/scope, and key actors for assessing long-term impacts on whales, dolphins and sea turtles.	Kyle Baker, BOEM
1:15	<p>Discussion of categories of impact research:</p> <ul style="list-style-type: none"> ● Distribution and abundance vs. baseline ● Acoustic signals (changes in rates, frequency) ● Physiological measures (health, stress, respiration) ● Reproduction and mortality (population level effects) <p>These discussions will use input from Day 1 on priority hypotheses or questions; research design; methods of monitoring; analytical methods.</p>	Discussion facilitated by Co-chairs, CBI
2:00	Stakeholder questions/discussion: Long-term impact research	Discussion facilitated by Co-chairs, CBI
2:45	BREAK	
3:00	Stakeholder questions/discussion: Long-term impact research, cont.	Discussion facilitated by Co-chairs, CBI

4:00	Final Discussion: What have we learned? What is most important? Summary, synthesis, and next steps	Co-Chairs, BOEM, MassCEC
4:30	ADJOURN	

Appendix B: List of Participants

Name	Affiliation
Kate Williams	Biodiversity Research Institute
Desray Reeb	Bureau of Ocean Energy Management
Kyle Baker	Bureau of Ocean Energy Management
Mary Boatman	Bureau of Ocean Energy Management
Stan Labak	Bureau of Ocean Energy Management
Pricilla Brooks	Conservation Law Foundation
Aaron Rice	Cornell Bioacoustics Research Program
Aileen Kenney	Deepwater Wind
Jason Roberts	Duke University Marine Geospatial Ecology Lab
Jack Clarke	Mass Audubon
Bill White	Massachusetts Clean Energy Center
Tyler Studds	Massachusetts Clean Energy Center
Kathryn Ford	Massachusetts Division of Marine Fisheries
Erin Burke	Massachusetts Division of Marine Fisheries
Bruce Carlisle	Massachusetts Office of Coastal Zone Management
Todd Callaghan	Massachusetts Office of Coastal Zone Management
Diane Borggaard	National Marine Fisheries Service
Sean Hayes	National Marine Fisheries Service
Debra Palka	National Marine Fisheries Service
Julie Crocker	National Marine Fisheries Service
Peter Corkeron	National Marine Fisheries Service
Catherine Bowes	National Wildlife Federation
Francine Kershaw	Natural Resources Defense Council
Dan Pendleton	New England Aquarium
Ester Quintana	New England Aquarium
Scott Kraus	New England Aquarium
Meghan Rickard	New York State Department of Environmental Conservation
Laura Morse	Ørsted
Stormy Mayo	Provincetown Center for Coastal Studies
Dom Tollit	SMRU Consulting
Chris McGuire	The Nature Conservancy
Kelly Macleod	UK Joint Nature Conservation Committee
Bob Kenney	University of Rhode Island
Len Thomas	University of St. Andrews
Sue Moberg	VHB
Matt Robertson	Vineyard Wind
Rachel Pachter	Vineyard Wind
Elizabeth James Perry	Wampanoag Tribe of Gay Head Aquinnah
Howard Rosenbaum	Wildlife Conservation Society
Mark Baumgartner	Woods Hole Oceanographic Institution

Appendix C: Research Questions and Hypotheses Matrix

PARAMETERS	ALL	MARINE MAMMALS	RIGHT WHALES	SEA TURTLES	ZOOPLANKTON
Multi-Scale/ Cumulative Impact	<p>***Is it possible to measure the cumulative impact of noise, both ambient and pile driving, over time in the WEA?</p> <p>***What is the cumulative effect of all the WEAs on migrating species (whales, turtles, fish)?</p> <p>***How do we account for/handle cumulative effects of wind energy projects, both across the east coast and time?***</p> <p>Will the build out of one wind farm, or the cumulative build out of the RIMA WEAs, affect the distribution and abundance of Calanus finmarchus and/or other plankton to an extent that results in significant caloric challenges to baleen whales?</p>		<p>Can we develop a coordinated survey that evaluates health/stress population impacts for NARW and other targeted baleen whale populations (individuals to populations)?</p> <p>*** What is the cumulative impact of wind turbine construction along the Atlantic coast on abundance, distribution, and behavior of NARWs?</p> <p>*** How do other threats change in response (e.g. how do ship strikes shipping patterns change related to whale distribution)?</p>		

PARAMETERS	ALL	MARINE MAMMALS	RIGHT WHALES	SEA TURTLES	ZOOPLANKTON
Population Size			Do individual displacement effects from pile driving cause population level impacts to NARWs? *** Does construction of wind turbines affect the abundance, distribution, and behavior of NARWs within the WEAs and broader region? *** Are the trends in detections of NARWs stable through time?		
Demography	How do we understand changes in vital rates to marine mammals?				
Health: physiological		Is there a change in body condition correlated with a change in abundance in the MA/RI WEAs.	Do NARWs experience elevated stress levels re: pile driving or wind farm operation? *** What is the impact of pile driving on whale stress levels? How do stress levels in/near the WEA during pile driving compare to control (quiet) areas? An effect size of 2x for stress hormones may be significant. *** What is the time course for stress responses of NARWs to increased noise levels from construction?		

PARAMETERS	ALL	MARINE MAMMALS	RIGHT WHALES	SEA TURTLES	ZOOPLANKTON
Health: energetic	How do we quantify sublethal effects?*** What happens if sublethal effects are discovered after project completion/operation begins? ***Is a change in body condition correlated with a change in abundance in RIMA WEAs?		What are health/reproduction implications of (worst case) completely losing the MWEA as a feeding habitat for NARWs? *** What portion of a given RW's annual caloric content is obtained while feeding in or adjacent to (w/in 20 km) of the RIMA WEAs? *** What is the dose-response to pile driving by RWs and its energetic consequences? *** Does the occurrence of wind farm construction lead to decreased feeding or calving rates in RWs? *** Are caloric intake levels for RWs affected by pile driving or operations? *** What are the energetic consequences of temporary or permanent displacement of RWs from foraging hotspots?		Does an array of wind turbines affect the current regime and therefore the development of Calanus patches (i.e. RW feeding sites)?

PARAMETERS	ALL	MARINE MAMMALS	RIGHT WHALES	SEA TURTLES	ZOOPLANKTON
Response: distribution	<p>Will the operation of 100 wind turbines result in significant exclusion of whales or turtles from previously-documented feeding grounds due to noise? To what distance from the farm will they be driven? *** Can we gain a better understanding through time of fin whale distribution and abundance in/around WEAS through acoustic detection/integration of data, so that data are more relevant at finer spatial scales? *** What is the spatial and temporal displacement of large whale species due to pile driving? ***What is the effect of wind farm operations/installation vs natural variability and climate change? Specifically, what is the change of typical prey spatially and temporally in the WEA? *** Are protected species (MM and sea turtles) displaced during wind farm</p>	<p>What is the spatial gradient displacement of harbor porpoises and bottlenose dolphins and turtles during pile driving and during normal operations? *** What are the main sources of acoustic noise over the lifetime of a wind energy project and how do these affect the behaviors of the various MMs?</p>	<p>Will wind turbines generate noise that will make NARWs remain below in the upper water column and therefore exposed to higher risk of collision with vessels? *** Are right whales displaced by construction and/or operation? If so, where do they go and is food quality better or worse? If not, are they attracted and does that make them more vulnerable to boating/fishing? How to isolate wind farm effects from climate change effects? *** Does operation of wind turbines affect the abundance, distribution, and behavior of NARWs within the WEAs and broader region? *** Will right whales be excluded from/abandon habitat in wind farm areas? If so, for what reasons? *** Will wind turbines displace NARW into high traffic vessel lanes? *** How does site characterization/construction/operations affect the distribution and abundance</p>	<p>Are sea turtle distributions affected by operational wind facilities (either displacement or attraction)? What is the radius of effect? *** Does seasonal sea turtle abundance within a WEA change at a level larger than pre-installation inter-annual variability? *** At what distance, if any, are sea turtles displaced by pile driving activity? What is the temporal duration of displacement? *** Are sea turtles excluded from areas with pile driving (gradient study)?</p>	<p>How/do turbines influence/impact plankton distribution at all stages? *** Will the operation of wind turbines on the scale of a single farm result in significant changes in distribution and abundance of Calanus due to noise? *** Do wind farms result in a change (or shift in species composition or abundance) in prey abundance/distribution that would impact distribution or abundance of</p>

PARAMETERS	ALL	MARINE MAMMALS	RIGHT WHALES	SEA TURTLES	ZOOPLANKTON
Response: distribution continued	<p>construction? If so, do they return after? If they return, is there a change in distribution or behavior in the WEA post-construction? *** Does pile driving lead to temporal/spatial displacement of marine megafauna? Are there different responses among different species? *** Are baleen whale distributions significantly affected by operational wind facilities? What is the radius of effect? (scale: single farm, effect size: 20% change) *** Has some statistic of timing of habitat use changed (1) by more than 2 weeks (2) at a rate similar to temperature or spring transition (~1day/year) - pick an area, species, and time of interest. *** What factors should be considered to determine the physical location of the towers that can reduce/minimize noise disturbance and displacement of endangered species?</p>		<p>of NARWs in WEAs? *** Why do RWs show up in the MA WEA during summer and fall? (understand for construction timing) *** Does offshore wind (1) construction and (2) operations displace NARWs from foraging habitat? (as a proxy for population-level effects). *** Are changes in distribution due to wind farms, changing prey, etc? *** Are RWs displaced by an operating wind farm?</p>		<p>MMs or sea turtles? *** Will wind farms alter oceanographic conditions that govern zooplankton aggregations and thus RW habitats? *** Does the presence of wind turbines alter the hydrodynamics in the area, thus affecting larval/zooplankton distribution?</p>

PARAMETERS	ALL	MARINE MAMMALS	RIGHT WHALES	SEA TURTLES	ZOOPLANKTON
Response: movement and behavior related	Is there a greater impact on whale behavior from pile driving in quiet versus loud habitats? *** At what received levels do 50% of MMs react to avoid pile-driving noise? *** How can we distinguish changes in whale behavior and ecology due to windfarm construction versus climate change?	What is the spatial and temporal displacement of large whale species from pile driving?	If WEA is part of the migratory path of RWs and they use it during their movements up and down the coast, how could a potential impact be identified? What constitutes an impact? *** What is localized movement of RWs? Dive behavior? *** Will wind turbines create barriers to NARW migration?	How do sea turtles respond to underwater noise/EMF and at what levels does it pose a risk to the population(s)?	
Response: physiological		Do MMs change their calling behavior (call rate, source level, call type) in response to pile driving?	Do RWs change their calling behavior (call rate, source level, call type) in response to pile driving?		

PARAMETERS	ALL	MARINE MAMMALS	RIGHT WHALES	SEA TURTLES	ZOOPLANKTON
Other	Do foundations result in lost recreational/charter boat gear and entanglements of turtles, seals, and small cetaceans? *** What is the operational impact on marine mammals and sea turtles? *** Null hypothesis to test: Noise from construction or operation of farms does not mask communications among whales which would impact feeding and mating efficiency.	Porpoise and dolphin-specific questions	Do the biological (prey) and oceanographic drivers of NARWs remain stable with time? How are these drivers changing in WEAs along NARW migration routes?		

Appendix D: Draft Experimental Outline: Short-term effects

Scenario

Season-long pile driving – *define temporal sequence (including day/night) and duration (6-9 months?) and spatial extent.* Sound characterization.

Species

- Not right whales as we assume all efforts will be made to operate when they are absent
- Baleen species: [no previous studies for pile driving; need review of response to other impulsive sound sources]
 - Humpback – Pros: readily detectable acoustically and visually; feeding behavior readily discerned; density can be moderately high.
 - Fin – Pros: readily detectable; sometimes feeding discernable; moderately high density. Cons: acoustic detections over long distances so hard to discern if near piling area.
 - Minke – Pros: high density; low acoustic detection range so readily located in vicinity of piles. Cons: cryptic feeding; less easily detectable from air
 - Sei – Pros: moderately high density some times of year; readily detectable. Cons: imprecise ranging (although not as bad as fin whales), needs more research
- Delphinids and Others [*ask for pros and cons; evidence of effect?*]
 - Common dolphin
 - White-sided dolphin
 - Bottlenose dolphin – some previous studies in Europe
 - Harbor porpoise – some previous studies in Europe
- Turtles [*previous studies?*]
 - Leatherback – high density on E side of wind energy area
 - Loggerhead
 - Kemp's Ridley
- *Pinnipeds?* – some previous studies in Europe
- *Fish?*

Scientific hypotheses

Hypothesis 1: Individuals of [species] are displaced over [distance] from pile driving activities for [time period]

Hypothesis 2: Individuals of [species] cease feeding over [distance] for [time]

Hypothesis 3: Individuals of [species] show elevated [stress hormone] over [distance] for [time]

Hypothesis 4: Zooplankton prey change their vertical distribution or density or patch structure over [distance] for [time]

Study designs to address hypotheses

Criteria

- Use proven technology (could envisage parallel stream developing technology for future studies)

- Undertake “power analysis” and cost-benefit analysis (what parameters will be measured; what precision; what use they are in a larger framework; how many \$\$s) prior to decision

Passive acoustic study

- Population-level (as opposed to individual-level) inference
- “Gradient” design with high intensity sampling within wind farm
- Frequency response of recorders needs to be matched to focal species to be studied
- Con: cannot tell difference between animals leaving and animals changing call behavior; does not work for some life history stages (e.g., mother-calves)/species; may mask short term impacts.

Visual aerial survey

- Population-level for most species, but individual-level responses for right whales
- Pros: Independent confirmation of density response; works for all species (to some extent)/life history stages; can observe behavior (e.g., feeding); less expensive and more responsive than surface surveys from ships
- Cons: Going to need a lot of flights!

Pseudo-experimental exposure (PEE) studies

- Analogy with CEE studies of Navy sonar (AUTEK, SOCAL, Atlantic BRS, 3S) and seismic (3S, BRAHSS)
- Individual-level study
- Con: One event study; sample size (in some sense) is 1: one site, one season.
- There is the potential to do a controlled exposure study (experimental pile driving), but unrealistic scenario temporally. *Discuss options for adjusting industrial-scale pile driving deployment schedules.*

Movement response

- Which species are amenable to tagging?
 - Baleen spp?
 - Delphinid spp?
 - Harbor porpoises
 - Sperm whales
 - Beaked whales
 - Seals
 - Turtle spp?
 - Fish?
- Dtags vs satellite (limpet) tags; new generation tags, multi-scale study? Pros and cons. Received level recording. Acoustic telemetry tags?

Stress response

- Collect whale blow

Prey field study

- Plankton; fish?

Appendix E: Draft Experimental Outline: Long-term effects

Worst case scenario of development

- Right whales unable to migrate
 - Impact?
- All species permanently excluded from development area and lose this as feeding area
- Impact – model with PCoD
 - Will raise a lot of questions about inputs – further studies likely needed

More realistic outcomes of development

- Hypothesis: Wind farm existence/operation has an effect on local spatial density of [species] in the vicinity of wind farms [be explicit about distance]
- Hypothesis: Wind farm existence/operation has an effect on migration of right whales
- Climate change makes windfarm habitat unsuitable or degrades habitat through changes in plankton abundance
- Wind farm operations have an effect on health and reproduction of right whales (PCoD?)
- Secondary effects

Study designs

- Acoustic study
- Aerial/shipboard survey
- Individual-based study – tags
- Oceanographic monitoring
- Index sites as proxy – hard to attribute causation

Other issues to consider

- Noise from wind farm operation – close to ambient?



BOEM
BUREAU OF OCEAN ENERGY MANAGEMENT

Offshore Wind Energy Development in the Atlantic

From A Regulatory Perspective

Desray Reeb, Ph.D.
Marine Biologist, Office of Renewable Energy Programs



Mandates

- “**The Outer Continental Shelf (OCS)** is a vital national resource reserve held by the Federal Government for the public, which should be made available for **expeditious and orderly** development, subject to **environmental safeguards**, in a manner which is consistent with the maintenance of competition and other national needs.”
 - **Outer Continental Shelf Lands Act (OCSLA) | Sec 3(3)**
- “... may grant a lease [for] energy from sources other than oil and gas ... in a manner that provides for safety and protection of the environment.”
 - **Energy Policy Act of 2005 | Sec. 388**

Regulatory Responsibilities

- “To declare national policy which will encourage productive and enjoyable **harmony between man and his environment**; to promote efforts which will **prevent or eliminate damage to the environment** and biosphere and stimulate the health and welfare of man; to enrich the understanding of the **ecological systems** and natural resources important to the Nation; and to establish a Council on Environmental Quality.”
 - **National Environmental Policy Act of 1969** | *Pub L. 91-190*
- “... provides for **the conservation of species that are endangered or threatened** throughout all or a significant portion of their range, and the conservation of the **ecosystems** on which they depend.”
 - **Endangered Species Act of 1973** | *16 U.S.C. §1531 et seq.*

Offshore Renewable Energy

- **Office of Renewable Energy Programs (OREP)**
- **Mission:** To regulate environmentally-responsible offshore renewable energy development activities.



Wind



Ocean Current



Wave



Transmission

OCS Renewable Energy Authorization Process

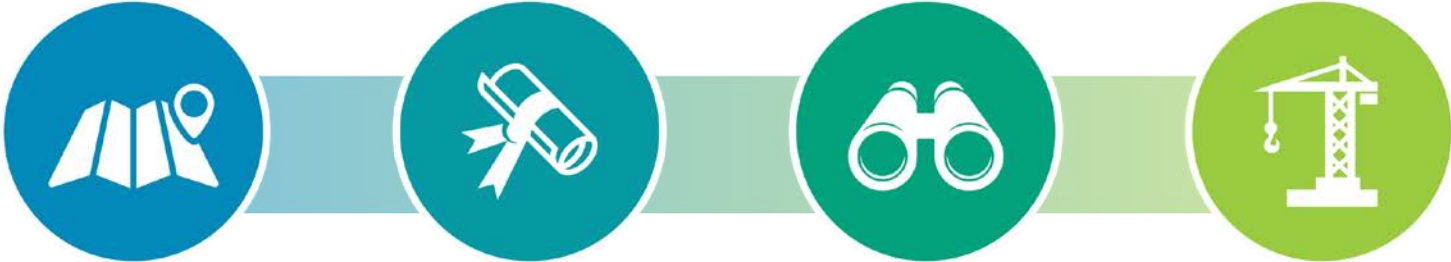

Planning & Analysis | **Leasing** | **Site Assessment** | **Construction & Operations**

2 Years

1-2 Years

5 Years

2 Years (+25)

Data Use

Natural and Cultural Resources

- Marine Mammals and Sea Turtles
- Birds
- Fish
- Habitat
- Restoration
- Historic and Cultural Resources

Human Activities

- Marine Transportation
- National Security
- Commercial Fishing
- Recreational Fishing
- Recreation
- **Energy and Infrastructure**
- Aquaculture
- Sand and Gravel

NORTHEAST OCEAN DATA

Maps and data for ocean planning in the northeastern United States

www.midatlanticocean.org/data-portal/
www.northeastoceandata.org

HUMAN DIMENSIONS



AQUACULTURE
Interactive Map



RECREATION
Interactive Map



COMMERCIAL FISHING
Interactive Map



MARITIME COMMERCE
Interactive Map



ENERGY & INFRASTRUCTURE
Interactive Map



CULTURE
Interactive Map

MARINE LIFE



MAMMALS & TURTLES
Interactive Map



FISH & SHELLFISH
Interactive Map



OTHER MARINE LIFE
Interactive Map



EELGRASS
Data Resources & Interactive Map



HABITAT
Story Map



Anticipated Release:
2015
BIRDS
Interactive Map

ENVIRONMENT



BATHYMETRY
Data Resources & Interactive Maps



WATER QUALITY
Interactive Map



Anticipated Release:
2015
RESTORATION
Interactive Map

Featured Map



IMPAIRED WATERS

Impaired waters designated by the Environmental Protection Agency.

Data Explorer



LAUNCH THE DATA EXPLORER

The Data Explorer provides maps of all available datasets. Any combination of data can be viewed on a single map.

What's Next?

Northeast Ocean Data adds data, maps, and website enhancements on a rolling basis. Find out what's currently in development.

UPCOMING PRODUCTS

Environmental Studies

Funds for Renewable Energy Information Needs | FY 2011-15 Cumulative (~\$30M)

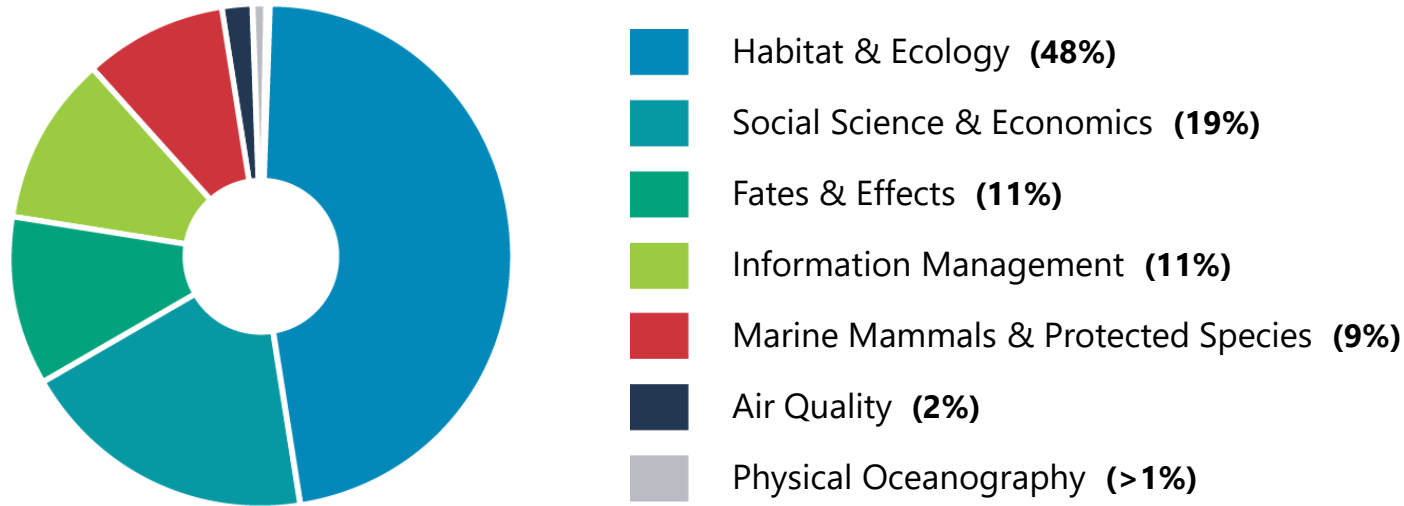

Includes obligations for studies in all regions supporting environmental information needs for renewable energy, totaling \$29.3 million

Environmental Studies

- Real-time Opportunity for Development Environmental Observations (RODEO) - pile driving measurements and evaluation as well as operational sound measurements
- Determining offshore use by marine mammals and ambient noise levels using passive acoustic monitoring (MD, VA)
- Northeast Large Pelagic Survey Collaborative Aerial and Acoustic Surveys for Large Whales and Sea Turtles



Continuing studies and Workshops

- AMAPPS II – possibly AMAPPS III. Final report for AMAPPS I available:
 - <https://www.boem.gov/espis/5/5638.pdf>
- MassCEC study in RI/MA to be extended for a 5th year.
- Atlantic Deepwater Ecosystem Observatory Network (ADEON) – An Integrated System for Long-Term Monitoring of Ecological and Human Factors on the OCS (Mid and South Atlantic)
 - <https://opendata.boem.gov/BOEM-ESP-Ongoing-Study-Profiles-2018-FYQ2/BOEM-ESP-AT-16-08.PDF>
- Characterize the acoustic fields radiated by marine geophysical survey systems
 - <https://www.boem.gov/ESPIS/5/5551.pdf>
- Best Management Practices Workshop for Atlantic Offshore Renewable Energy Activities
 - <https://www.boem.gov/Final-Summary-Report-for-BMP-Workshop-BOEM/>

OCS Study
BOEM 2017-071

Atlantic Marine Assessment Program for Protected Species: 2010-2014



US Department of the Interior
Bureau of Ocean Energy Management
Headquarters

BOEM
Bureau of Ocean Energy Management

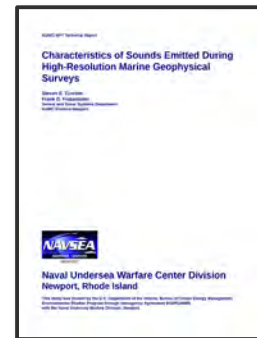

OCS Study
BOEM 2018-015

Summary Report: Best Management Practices Workshop for Atlantic Offshore Wind Facilities and Marine Protected Species



US Department of the Interior
Bureau of Ocean Energy Management
Atlantic OCS Region

BOEM
Bureau of Ocean Energy Management

Status of Offshore Renewable Energy

Leasing

- Since 2009, BOEM has issued 13 commercial wind energy leases in the Atlantic
- Upcoming Lease Sales in MA & NY

Site Assessment Plans (SAP)

- 3 approved (MA, RI, VA)
- 3 processing (MD, MA, NJ)

Construction and Operations Plans (COP)

- 1 approved (Cape Wind)
- 1 processing (Vineyard Wind)
- Anticipate COPs from RI/MA/NJ/DE/MD leases within the next 2 years
- **Planning activities continue off Carolinas and the New York Bight**
- **Management and incorporation of results from 11 ongoing environmental studies, 6 ongoing technology studies and dozens of completed studies.**
- **14 Intergovernmental Renewable Energy State Task Forces**
- **Regulatory review & guidelines (e.g., Design Envelope)**

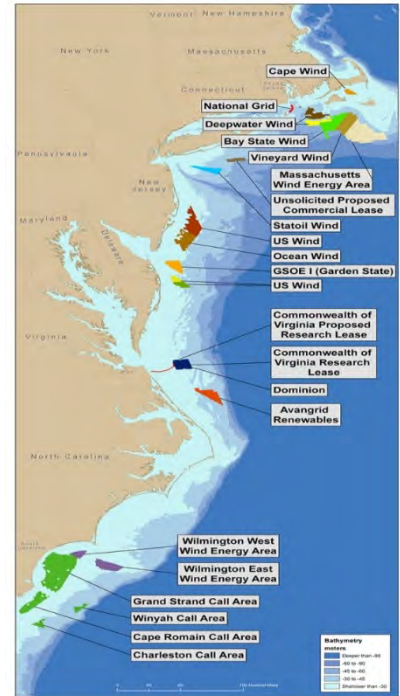

Thank you!



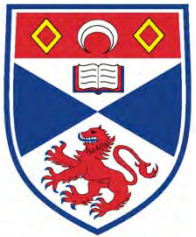

University
of
St Andrews



Summary of European Studies on the Effects and Monitoring of Wind Facility Construction and Operation Using Passive Acoustic Methods

Dominic Tollit

SMRU Consulting Canada

BIG PICTURE: Frameworks for modelling the potential impacts of wind farm noise on populations

- Population frameworks in use (iPCOD and DEPONS) have similar basic approach
 1. Model spatial variation in animal distribution and received noise levels (PAM used to collect source level data)
 2. Use noise exposure criteria to estimate the number of individuals disturbed (dose-response) or with PTS (PAM data used to estimate response to noise in DEPONS)
 3. Estimate how disturbance or PTS affects an individuals' reproductive probability or mortality risk (iPCOD uses expert opinion)
 4. Apply these changes in a population model to explore longer term trends in relation to baseline

Passive acoustic monitoring techniques used in Europe

Main focus on harbor porpoise and dolphins (v. high frequency range and sampling rates required) and construction period.

- Static PAM (archival – bottom moored – Click detector (POD) by Chelonia Ltd most widely used PAM device as large focus on harbor porpoise – not suitable for baleen whale detection. SM3M, EARs, Soundtraps used to monitor piling source levels (single pulse SEL) and ambient noise).
- Static PAM (Transmitting - buoy-based – often mitigation monitoring focused – PAMBuoy/CAB SA instrumentation, Seiche and RTsys)
- Towed PAM (Often combined with larger scale visual surveys (eg SCANS) and so potentially used in EA site selection, ground truthing, regional monitoring)
- Drifting PAM, Animal-borne tags, and Autonomous Vehicles (not currently used in Europe for wind farm monitoring studies)

T-POD and C-POD use

- PODs incorporate a hydrophone, an analog processor, digital logging and memory storage. It can be programmed to detect specific frequency bands according to the targeted species, with 16 bands available ranging from 9 kHz to 170 kHz. The duty cycle can be set by the user.
- PODs use dedicated software to analyze and filter out cetacean clicks, which can be distinguished from other sounds using click train patterns. Only records data that it identifies as originating from the target species.
- Harbour porpoises studies typically set target filter at 130 kHz and a reference filter at 90 kHz. Bottlenose dolphin use target filter of 50 kHz.
- Recent studies have undertaken independent calibrations to ensure consistent sensitivity. Potential flow noise issues that can lead to loss of monitoring period. Can last ~3 months no duty cycle. Relatively cheap.

Review of BACI POD-based European wind farm monitoring studies

Author(s)	Wind farm location	Construction type # of turbines	Deployment duration (baseline)	Survey type	Methods and Results	Additional Notes
Tougaard et al. 2005	Nysted (Denmark)	Gravity base (and one vibratory pile) N=72	3+ yrs (1 yr baseline)	BACI 4 in I 4 in C (10 km east)	Porpoises clearly abandoned impact general area during construction. Two years after construction presence in impact site trending towards baseline values	
Thompson et al. 2010	Beatrice (Scotland)	tri-pile n=2	2.5 yrs.	Control-Impact 1 in I 1 in C (20 km + SW)	Low detections rates in both impact and control sites, other anthropogenic noises in area during study led to inconclusive results. Recommended gradient design	Employed ground-truthing in the form of visual surveys: 20 km transect lines through the impact area during PAM study.
Scheidat et al. 2011	Egmond aan Zee (Holland)	Monopile N=36	3 yrs (1 yr baseline)	BACI 2 near turbine, 3 in two C areas 10 km away, 1.8km apart	Porpoise acoustic activity significantly higher inside the wind farm vs. control areas post-construction. Long-lasting positive effect (habituation/enrichment)	No recording during construction phase. Used historical sightings data to compare expected porpoise numbers.
Teilman & Carstensen et al. 2012 (follow up study)	Nysted (Denmark)	Gravity base (one vibratory pile) N=72	10 yrs (8 month baseline)	BACI 3 in I, 3 in C (10 km E), in 1.9km sided triangle	Decreased porpoise activity (time between click trains) in impact area during construction. Sign incr. in activity after construction but impact area has not returned to 2002 baseline	Stated assumption that echolocation activity is correlated to porpoise density, no ground-truthing to verify.

Review of Gradient POD-based European wind farm monitoring studies

Author(s)	Wind farm location	Construction type # of turbines	Deployment duration (baseline)	Survey type	Methods and Results
Brandt et al. 2011	Horns Rev II (Denmark)	Monopile N=91	6 months (5 weeks baseline)	Gradient sampling 8 T-PODs in six locations (0.25-21 km from turbine) Piling noise (SEL) using buoy 720 m from pile at 1.5 m above seabed.	Negative effect of construction on porpoise acoustic activity detectable to a distance of 17.8 km. Gradient sampling allowed estimate of distance at which pile driving noise no longer negatively affected porpoise activity. Used porpoise positive minutes per hour and GAM to allow for a non-linear effect of pile driving. Interactions between Hour after pile driving and POD position, Distance to pile driving and Time of day were chosen as non linear predictor variables
Dayne et al. 2013	Alpha Ventus (Germany)	Monopile N=12	3.5 years (9 months of baseline)	Gradient 12 C-PODs (1-50 km away – see figure)	During construction significantly lower detection rates out to 10.8 km and higher at pods at 25 and 50 km suggesting displacement. Used GAM analysis to examine changes in DP10min/h and GLMM on waiting times after piling. Also used aerial survey data. AADs in use.
Graham et al.	Beatrice (Scotland)	Jacket piling (4 piles per turbine) N=84	10 months (2 months baseline)	Gradient and BACI (25km ² box), plus hotspot monitoring for BND. SM3M/Soundtraps at 6 locns. for 8 mo. Used for SEL noise modelling. C-PODs at 65 locations for 10 months (see figure)	Dose-response study - 50% probability of response @ 144-160 SEL, decreasing as more piling occurred. Response at close distance increased with AAD use. Change in harbour porpoise occurrence and distance from piling/received noise level used the proportion change in DPH in the 6, 12 or 24-hour period immediately following the end of piling, relative to a baseline of the same length 48 hours before the start of piling in control block. Response = >50% decrease in occurrence was greater than 50%. Concurrent POD studies also used waiting time to detection after piling as metric of effect.

Alpha Ventus C-POD gradient monitoring design (from Dayne et al.)

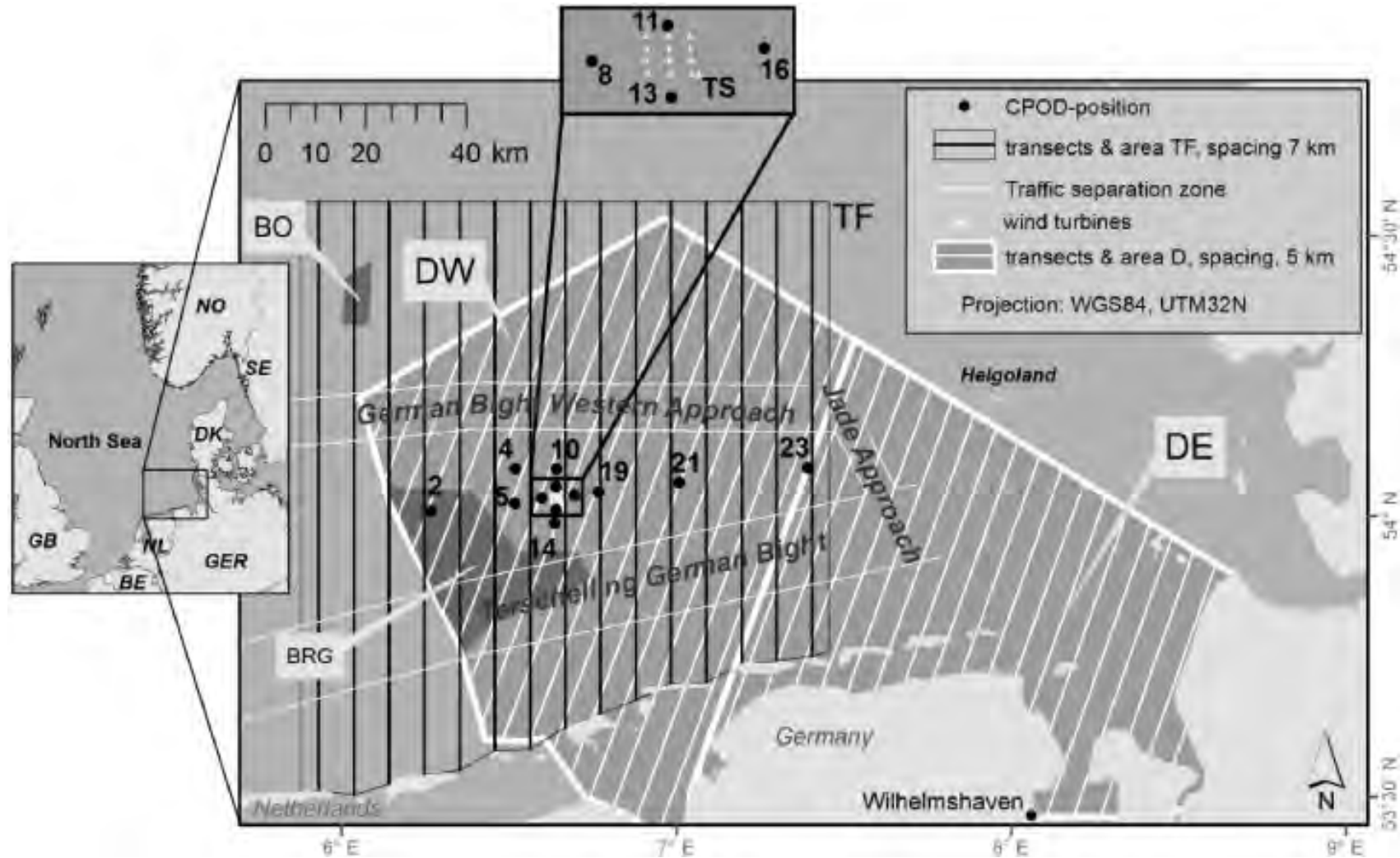

Beatrice C-POD gradient and BACI monitoring design (from Graham et al.)

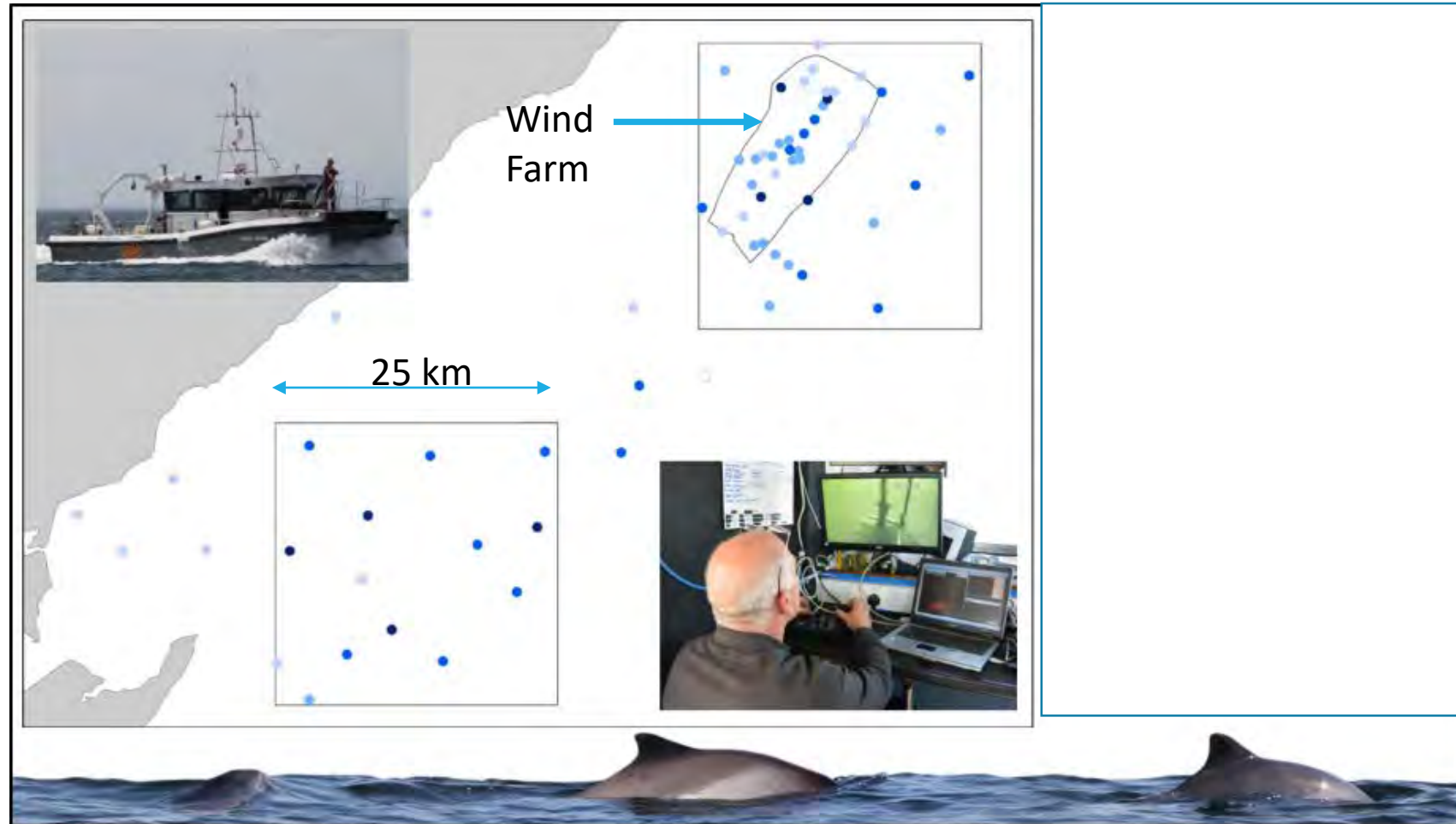

Best practices for baseline PAM of offshore wind farms (adapted from Carduner 2013 – based on European POD studies)

- 1) *Data should be collected for at least one full year prior (ideally two) to construction and one full year post-construction. Longitudinal follow-up studies currently also being undertaken.*
- 2) *Data should be recorded during construction (including piling source levels).*
- 3) *Broadband sampling should be utilized in addition to species-specific data collection (if duty-sampling used needs to be consistent though the day across periods).*
- 4) *Gradient sampling recommended.* Gradient sampling is especially useful in measuring spatial and temporal impacts
- 5) *A ‘control’ site if used should be located at least 20 km away from the ‘impact’ site, with similar as possible to the depth, current, tidal impact, and distance from shipping lanes.*
- 6) *Ground-truthing in the form of visual observers should be employed to confirm and corroborate results of PAM data collection (Determine absence v reduced vocal activity, as well as ID)*
- 7) *Baseline data collection should look beyond impacts to one particular species.*
- 8) *GAMs and GLMMs used with POD data to assess effects (using DPH or DP10min/H, wait times linked with single pulse SEL estimates to determine dose-response)*

Relevant reports and studies

- Macleod et al. (2010). SMRUC report to TCE on “Approaches to marine mammal monitoring at marine renewable energy developments” Methods review.
- Wilson et al. (2018). SMRUC report to JNCC on “Design of a monitoring plan for the Southern North Sea candidate Special Area of Conservation and wider area”. Used simulations to assess power to detect change in porpoise population. Static PAM recommended at spacings of 35-40 km.
- Thompson et al. (2013) used gradient and BACI C-POD study. Porpoise groups avoided 10 day seismic survey at 5–10 km, but returned after 1 day. Significant decrease in occurrence was detected over survey period, but this effect was small in relation to natural variation.
- Increasing effort to use PAM to estimate density. Marques et al. (2009) used static PAM and cue rates from DTAGs. Kyhn et al (2012) adapted point transect sampling methodology combining T-POD detections and visual “marks”. Williamson et al. (2016) compared visual surveys with DPH and good correlation (0.73). Comprehensive review of *Density Estimation for Cetaceans from passive Acoustic Fixed sensors (DECAF)* by Booth et al. (2017) for JIP. Power analyses and simulation exercises to explore the feasibility and utility of implementing DECAF methods considering different PAM survey designs, species vocal characteristics (cue production), and DCLs under various environmental conditions. Also second report assessing viability of DECAF (Booth et al. 2017b).

Static PAM

Strengths

High temporal resolution through continuous monitoring

Relatively inexpensive (for bottom moored devices)

Long-term data collection possible

Can be used to monitor relative abundance depending on assumptions (growing potential to estimate density for some species)

Recordings are available for independent verification

Allows concurrent monitoring of different areas of the site

Weaknesses

High frequency detection range is limited to approximately 200m

Limited detection ability for highly directional sounds

Retrieval of bottom moored devices is required to obtain the data

Background noise compensation only possible with some devices or if other noise monitoring devices deployed

Limited ability to define detection range

Vessel-based PAM

Strengths

Method independent of daylight and most weather conditions

High spatial resolution data

Relative abundance estimate and species identification for harbour porpoise established

Recordings are available for independent verification

Weaknesses

Expensive: high operational costs

Expensive: time-consuming post-processing costs

Performance dependent on vessel noise / ambient noise

Limited detection ranges of high frequency vocalisation ~200m

Limited detection ability for highly directional sounds

Possibility of responsive movement (animal movement in relation to the vessel)

Navigational constraints in areas of high anthropogenic utility (shipping, fishing, off-shore wind developments)

Provides 'snapshots' of abundance

Concurrent monitoring of different areas of the site not possible unless multiple craft used

Unmanned Autonomous Vehicles

Strengths

Long missions possible for some devices (e.g., solar powered)

Weaknesses

Long transit times

Slow survey speeds

Performance dependent on vessel noise/ ambient noise

Subject to deviation from transect lines, due to weather/ navigational constraints

Risk of device loss unknown and replacement expensive

Reliability to complete missions is unknown for some newer technologies

Thanks



Summary of European Studies on the Effects of Wind Facility Construction and Operation Using Aerial and Shipboard Surveys

Dr Kelly Macleod: Senior Marine Species Advisor

Kelly.Macleod@jncc.gov.uk



JNCC is a statutory advisor to the UK Government and devolved administrations on nature conservation

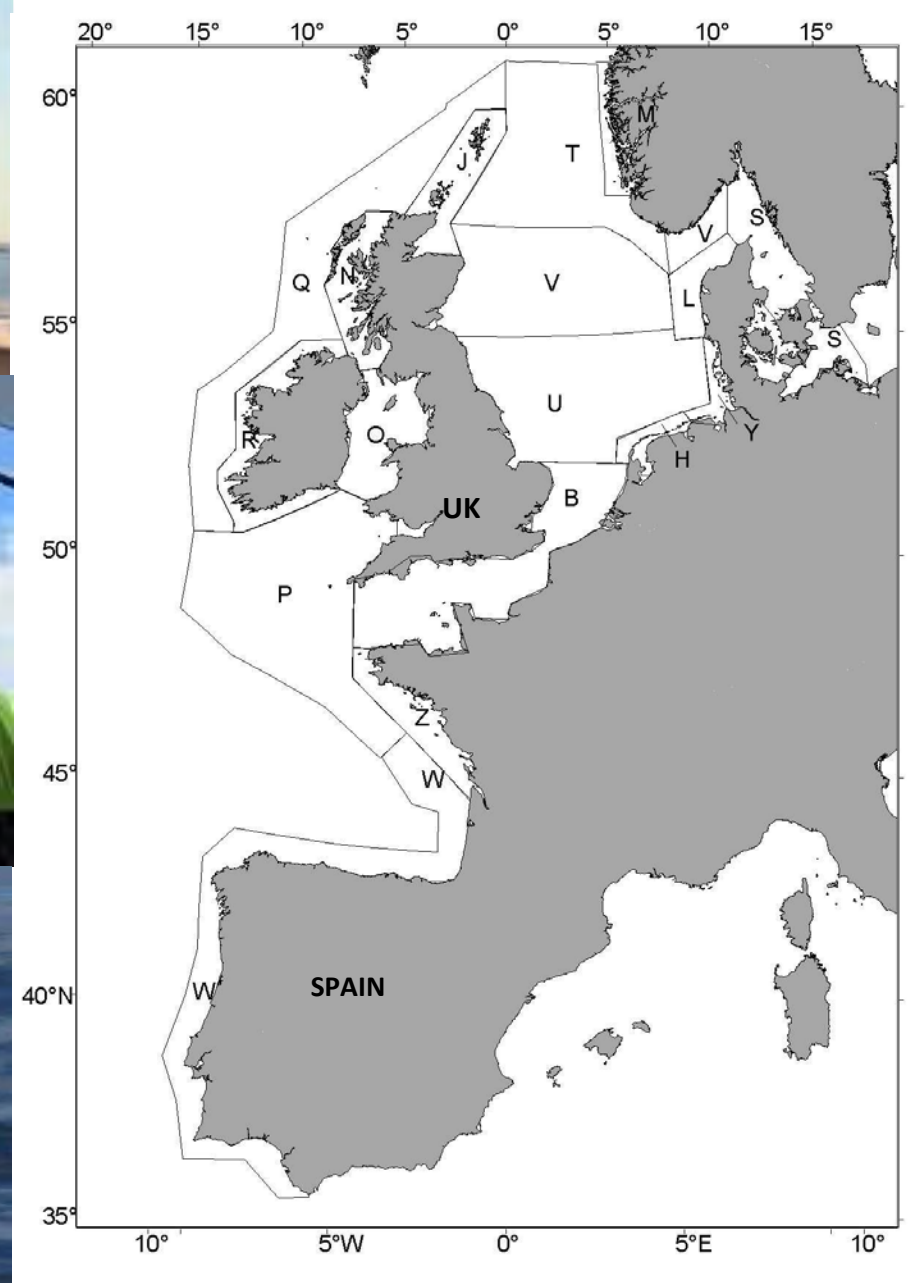

**Small Cetacean Abundance in the European Atlantic and North Sea
SCANS**

SCANS III / Nina Planck



From McCauley et al. 2015

Global offshore market

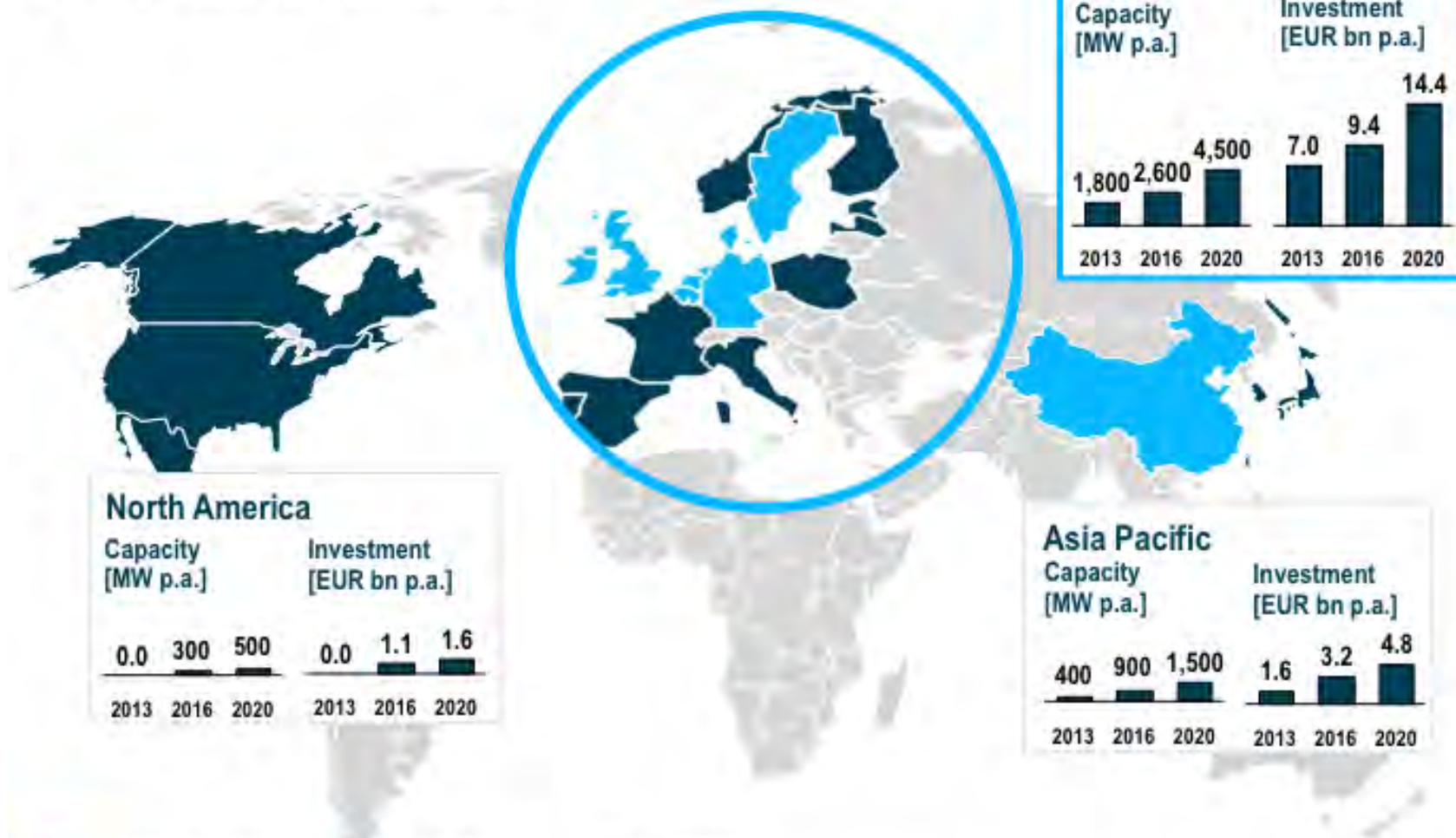

■ Offshore projects
 ■ Plans for offshore
 ■ No activity

Rationale: Investment costs per MW: 2013: EUR 3.9 m, 2016: EUR 3.6 m, 2020: EUR 3.2 m

Source: EER; BTM; Global Data; Roland Berger

Monitoring marine mammals



- Site characterisation surveys
- Limited focus on operational impacts
- Characterising the response to pile driving at local scale
- Understanding response at population level
 - Modelling of combined datasets
 - JCP (Joint Cetacean Protocol)
 - DEPONS (Disturbance Effects on the Harbour Porpoise Population in the North Sea)



Effects of offshore pile driving on harbour porpoise abundance in the German Bight

Assessment of Noise Effects

Final Report

Miriam J. Brandt, Anne-Cécile Dragon, Ansgar Diederichs, Alexander Schubert, Vladislav Kosarev, Georg Nehls, Veronika Wahl, Andreas Michalik, Alexander Braasch, Claus Hinz, Christian Ketzer, Dieter Todeskino, Marco Gauger, Martin Laczny, Werner Piper

Husum, June 2016
Prepared for Offshore Forum Windenergie

- Baseline: absolute densities of harbour porpoise
 - Large areas, multiple developments
- Post-piling surveys
 - More responsive than ships to temporal windows

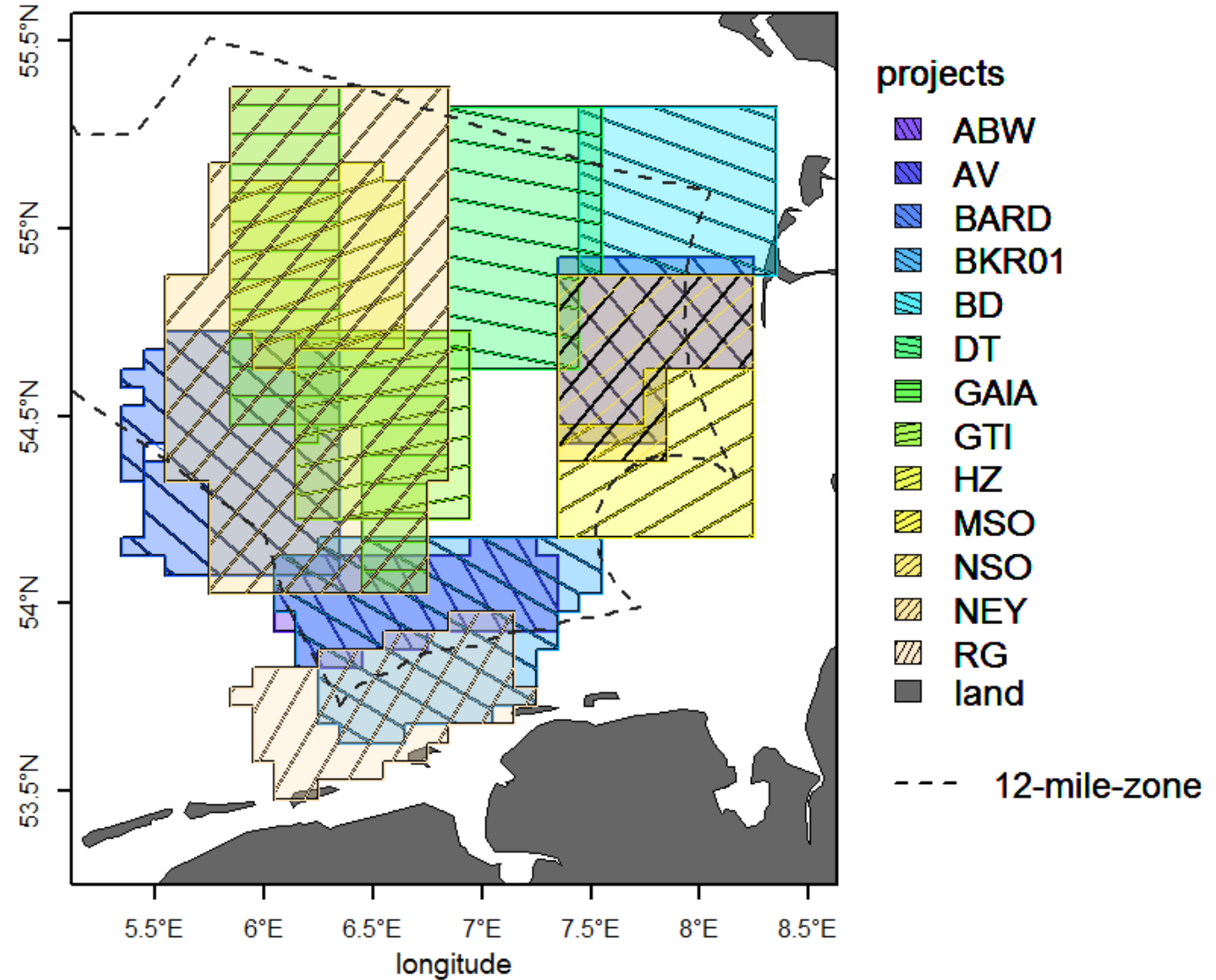

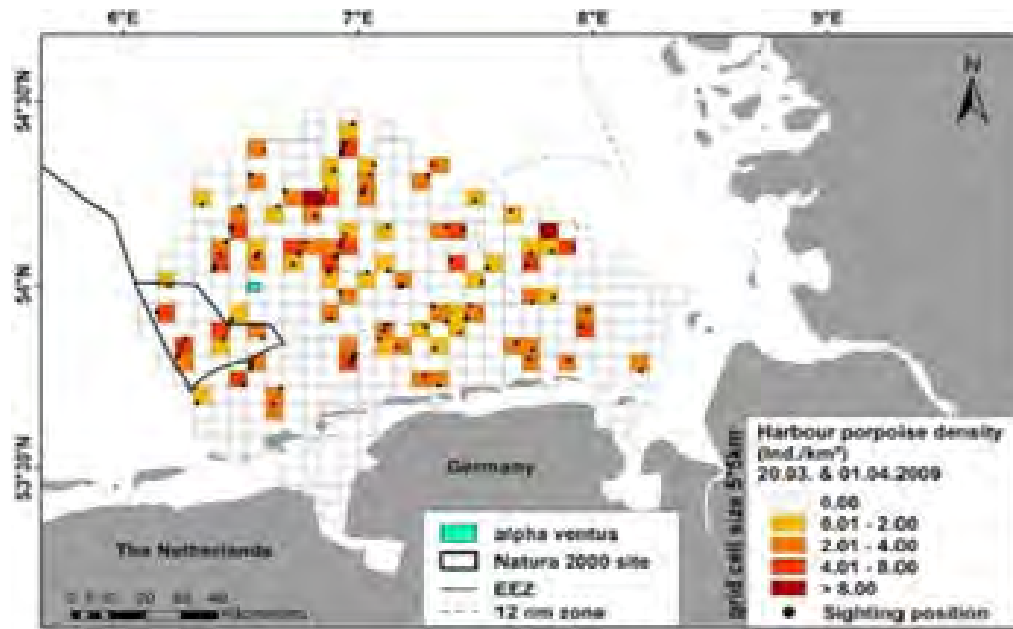

a)

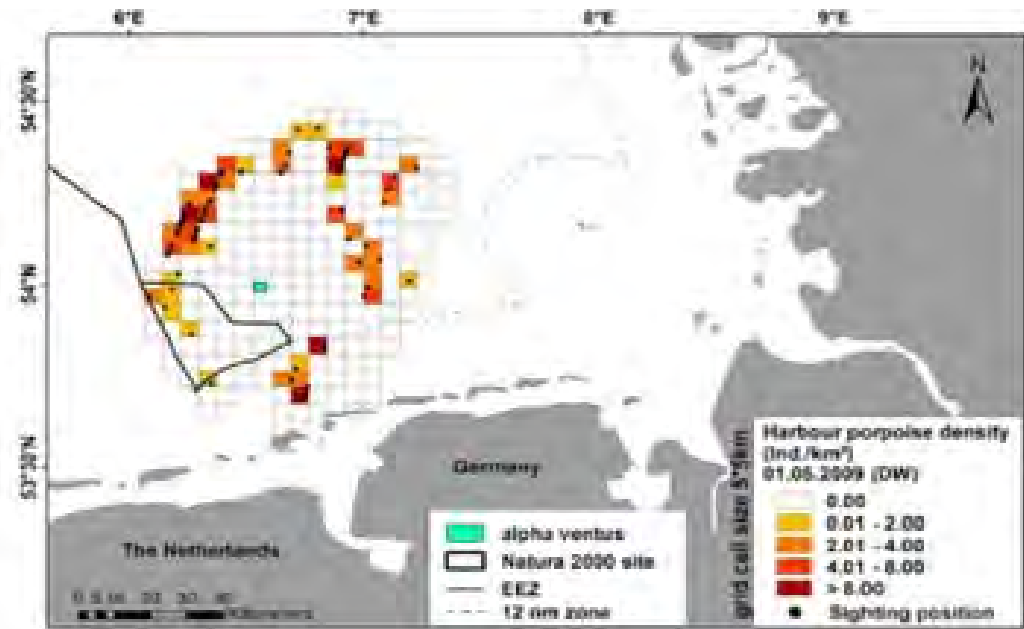

b)

Figure 3 from Effects of pile-driving on harbour porpoises (*Phocoena phocoena*) at the first offshore wind farm in Germany a) before and b) during piling. Michael Dähne et al 2013 Environ. Res. Lett. 8 025002 doi:10.1088/1748-9326/8/2/025002

- Porpoise density reduced up to 19km
- >23km porpoise density > mean density
- Return time is relatively short

560m



183m



76m



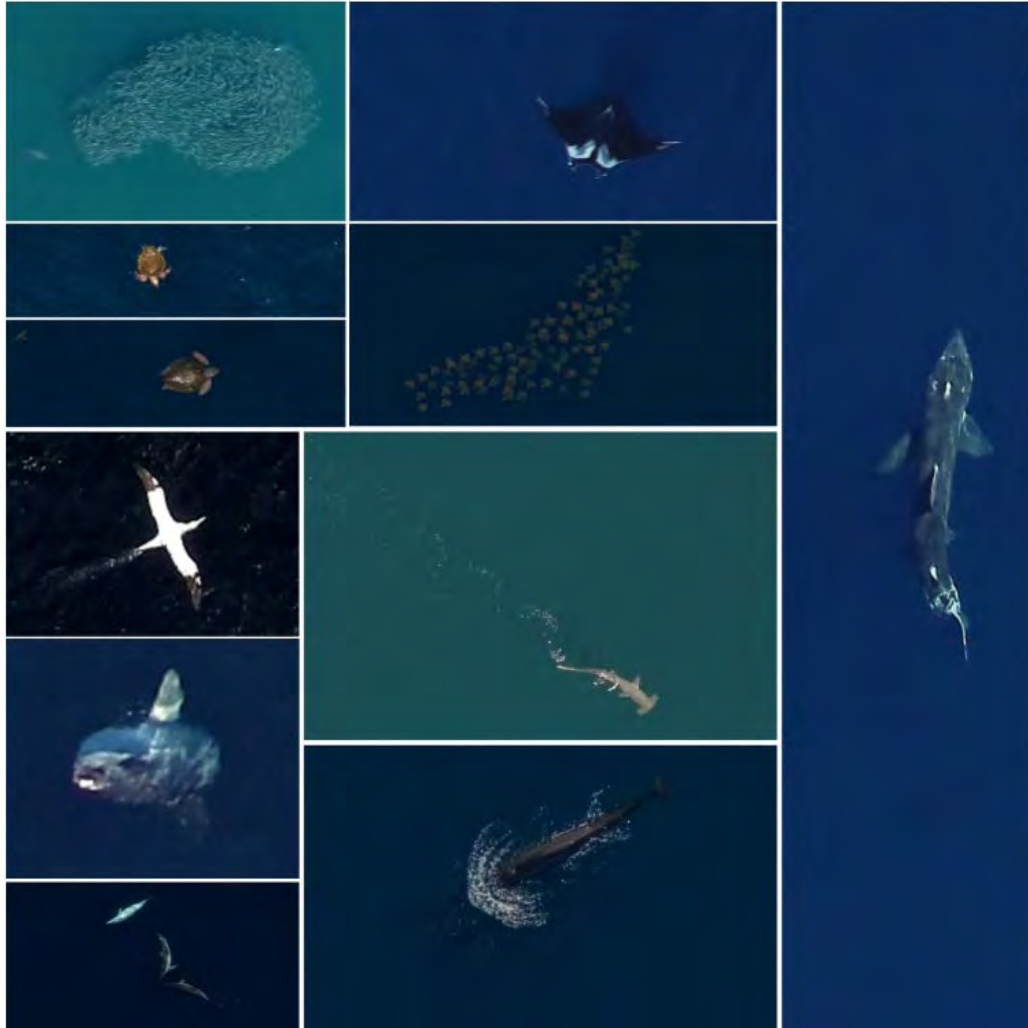

- Higher flying
- Combine seabird and cetaceans
- 1-2cm resolution on the ground – species ID good

- Challenges
 - Availability bias
 - Costly

https://remote.normandeau.com/nys_overview.php

Baseline and population trends

Joint Cetacean Protocol <http://jncc.defra.gov.uk/page-5657>

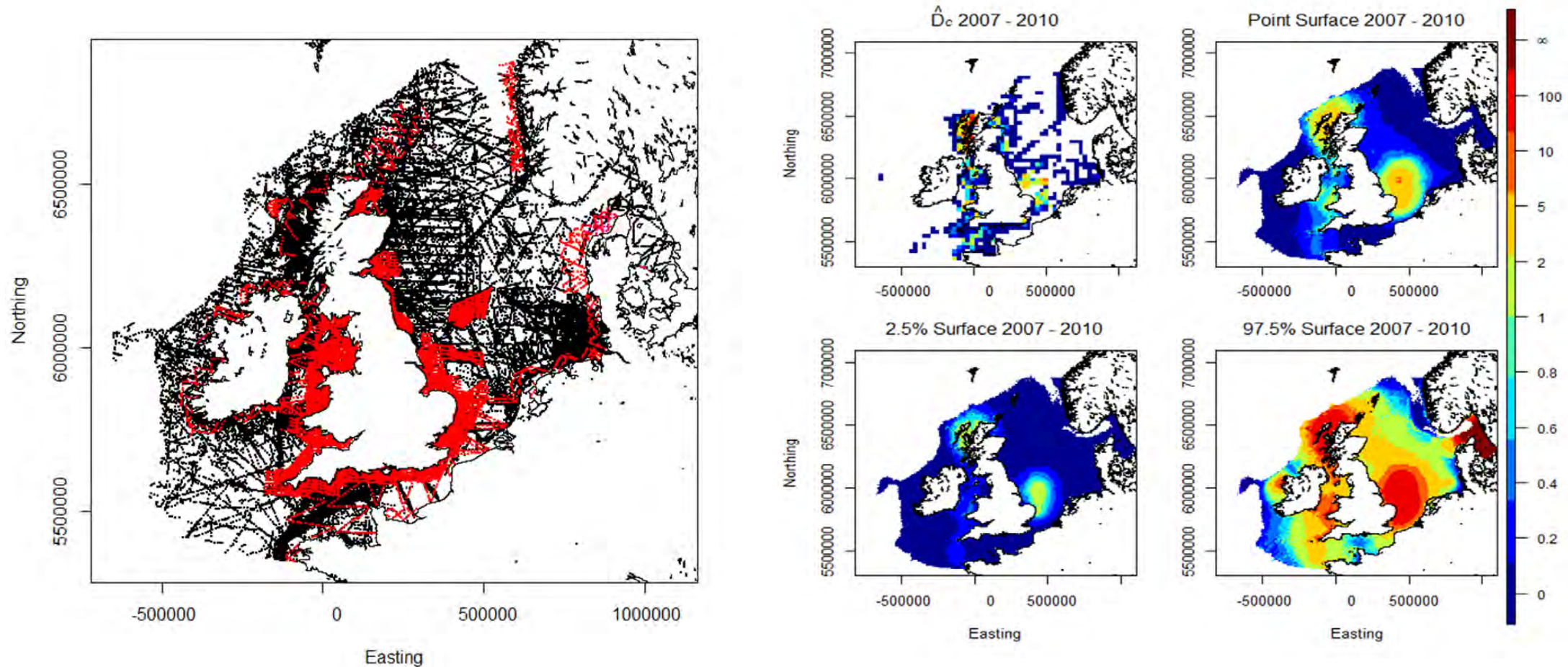

Industry data collection

R1

- Pre-consent characterisation; Before-After
- Small scale boat based
- Seabird and cetaceans combined (Camphuysen)

R2

- Pre-consent & impact for seabirds; strategic aerial
- Cetaceans not required – just mitigate

R3

- Much larger development 'zones'
- Impact monitoring – consent requirement to fund DEPONS

- High natural variability in cetacean density- what's normal?
- Imprecise cetacean estimates
- Developments limited spatially and temporally
- Good evidence that disturbance will occur



RenewableUK previously: BWEA

Disturbance Effects on the Harbour Porpoise Population in the North Sea (DEPONS)

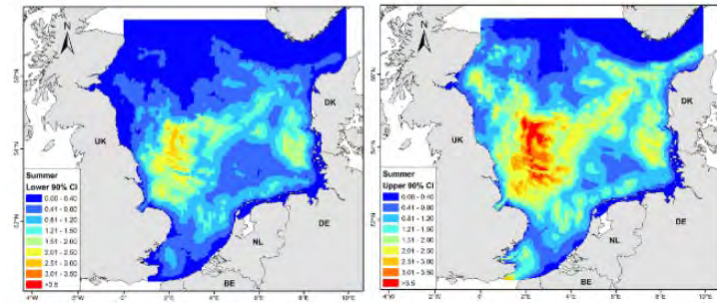
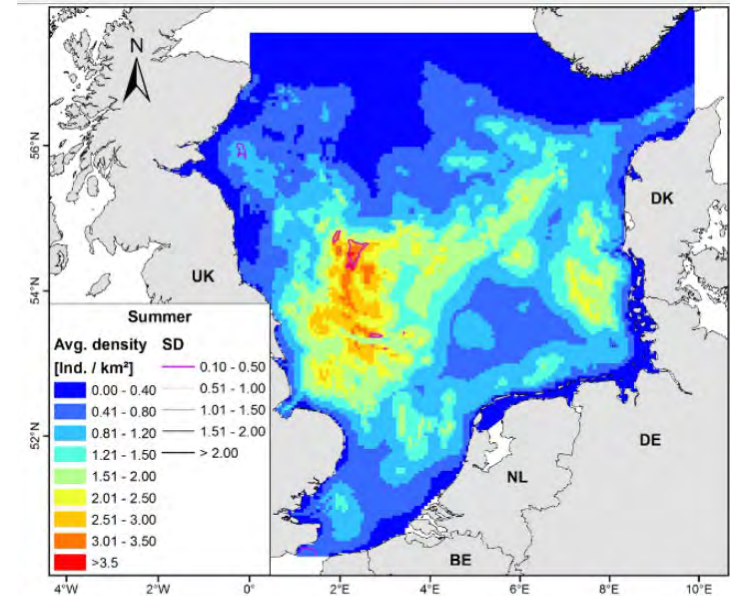
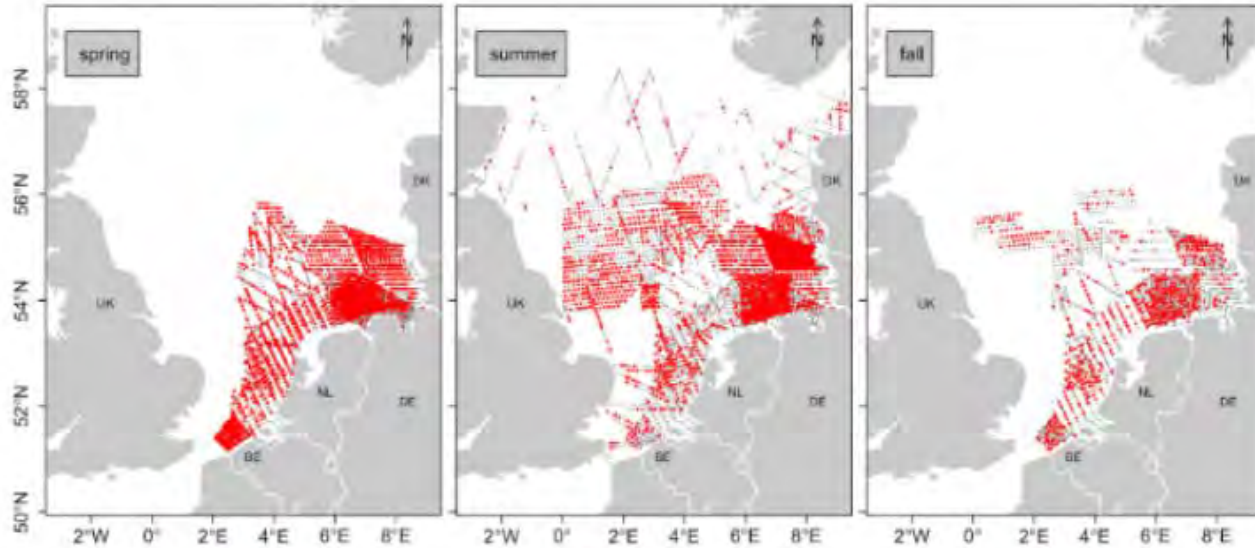

Spatially explicit modelling framework for predicting impacts of anthropogenic disturbances on marine populations based on their influence on animal movement and foraging

Nabe-Nielsen et al 2018. *Conservation Letters*

Gilles et al. 2016

Summary



- Boat and aerial surveys used for:
 - characterisation surveys
 - Impacts of pile driving
- Digital aerial now widely used given increasing turbine size
- Collation of multi-platform data can increase spatial and temporal coverage
- Detecting population changes from abundance measurements in the short-term is challenging; power analysis essential
- Other methods needed for vital rates
- Strong partnerships with all stakeholders

Thank you for your attention



Kelly.Macleod@jncc.gov.uk



FIGURE 2
BOTTLENOSE DOLPHIN TURSOPS TALUNCATUS
COURTESY OF THE UNIVERSITY OF SAARLAND



FIGURE 3
CHELONIA LT'S OPGD WHICH RECORDS
DOLPHIN AND PORPOISE ECHOLOCAATION
CLICKS



AERIAL SURVEYS OF MARINE MAMMALS

Ester Quintana, Scott Kraus, and Sarah Leiter
Anderson Cabot Center for Ocean Life at the New England Aquarium

BACKGROUND

- October 2011 – November 2012: Monthly aerial surveys of marine fauna in the MA WEA.
- December 2012 – June 2015: Survey area expanded to include RIMA WEA.
- February 2017 – May 2018: Aerial surveys continued in the MA and RIMA WEAs.

Main Objective:

- *2011-2015: Collect visual and acoustic baseline data on distribution, abundance and temporal occurrence patterns of marine mammals, in particular endangered whales and sea turtles.*
- *2017-2018: Document the ecological factors contributing to the distribution, abundance, and timing of right whale occurrences in the wind energy areas.*

STUDY AREAS

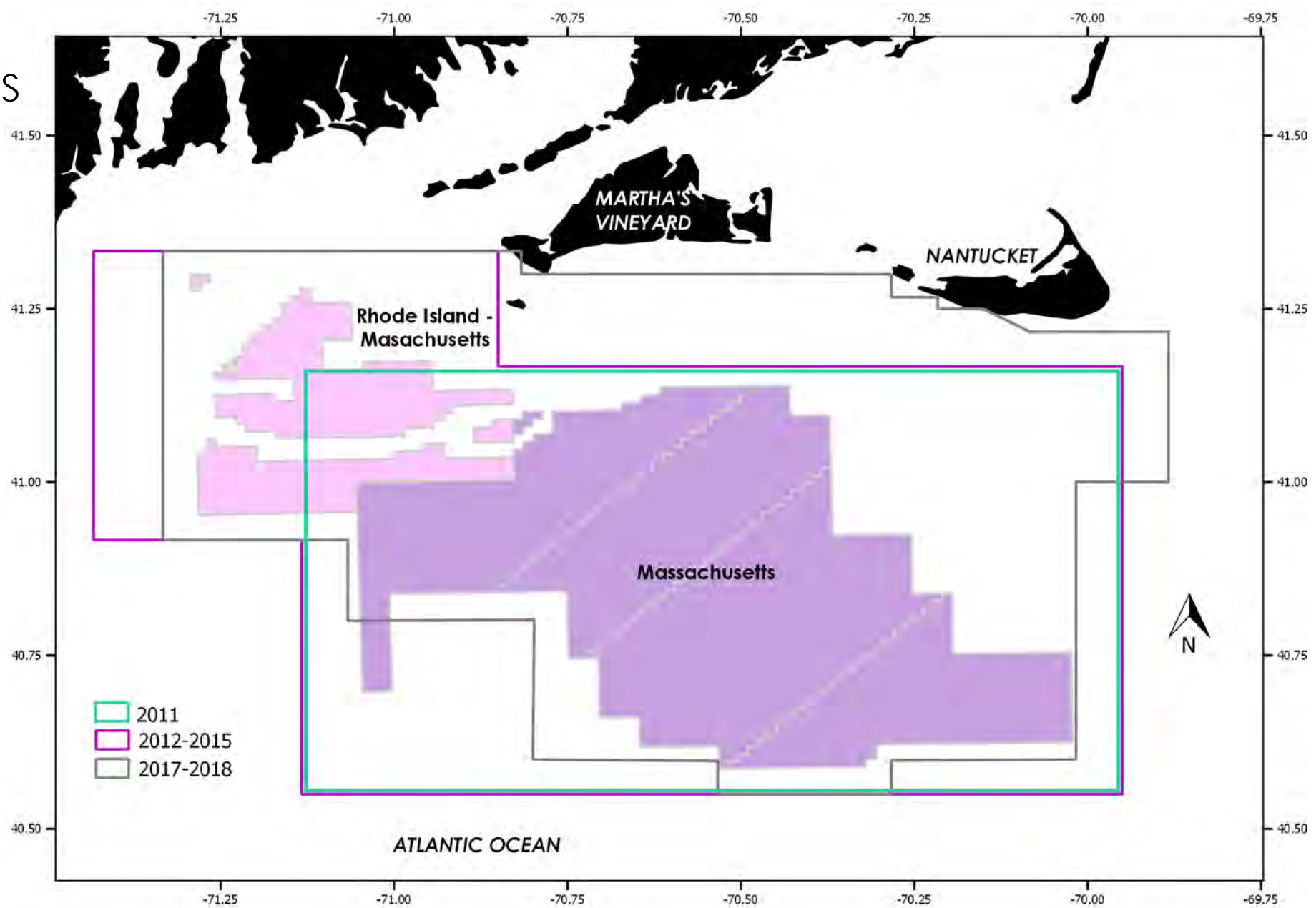

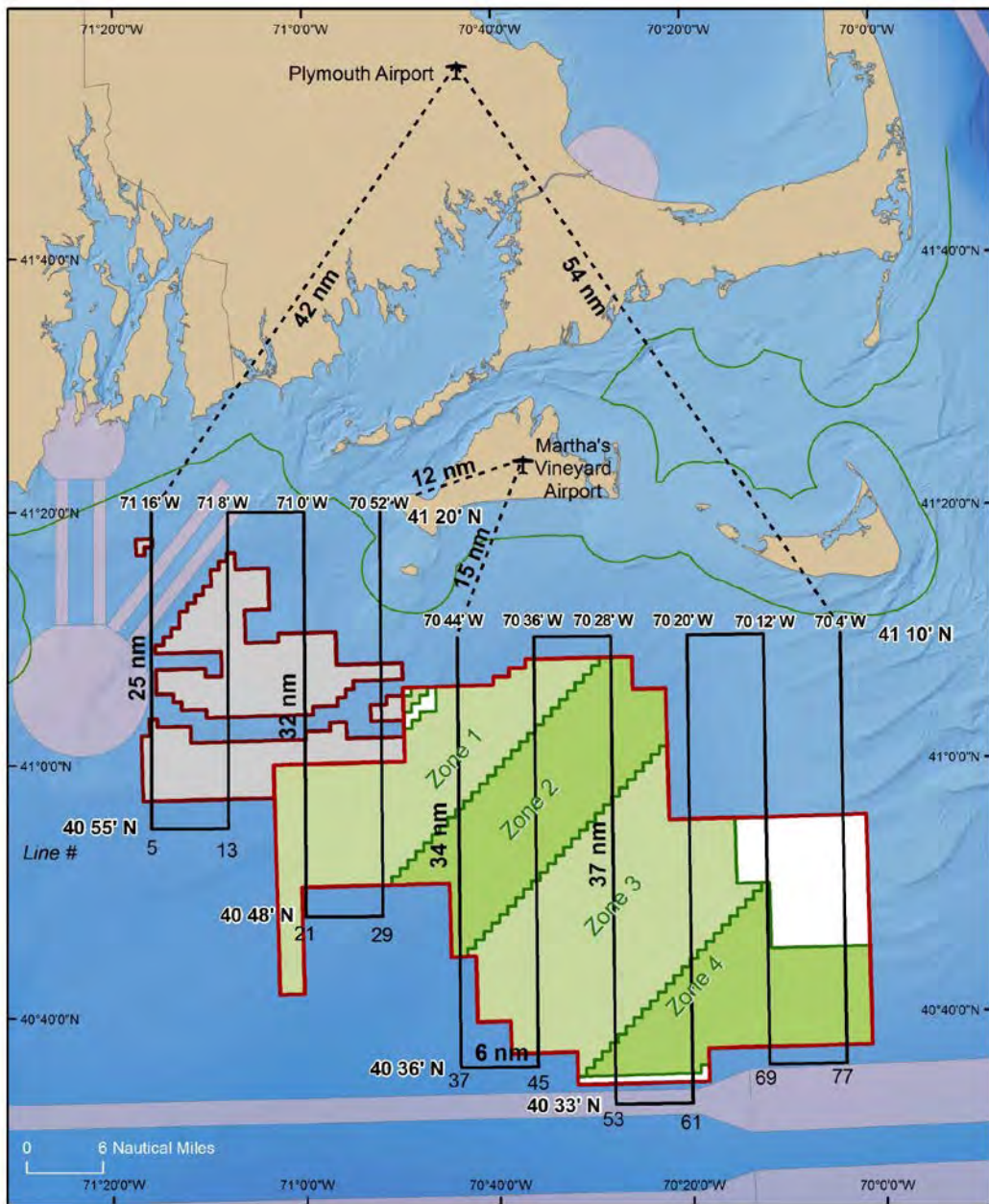

Example of survey track of a general survey (2017-2018)

- 10 track lines
- Track lines: 6 nm apart, 25 – 37 nm long



TOTAL AERIAL SURVEY EFFORT (KM, # SURVEYS) IN THE WIND ENERGY AREAS

93,028 Km in 104 surveys in 57 months

	AREAS	JAN	FEB	MAR	APR	MAY	JUN	JUL	AUG	SEP	OCT	NOV	DEC	TOTAL	
2011	MA											1,672 (2)	1,698 (2)	1,349 (2)	4,719 (6)
2012	MA MA, RI, MK, NZ	1,559 (2)	853 (1)	2,796 (3)	2,119 (2)	1,977 (2)	1,790 (2)	1,610 (2)	2,079 (2)	1,737 (2)	910 (1)		344 (1)	17,755 (20)	
2013	MA, RI, MK, NZ		1,798 (2)	1,105 (1)	2,571 (4)	1,100 (1)	2,157 (3)	903 (1)	1,783 (2)	1,060 (1)	610 (1)	2,018 (2)		15,103 (18)	
2014	MA, RI, MK, NZ	1,119 (2)	1,523 (2)	908 (1)	1,530 (3)	896 (1)	2,315 (2)	2,000 (2)	2,117 (2)	1,991 (2)	856 (1)	809 (1)	2086 (2)	18,148 (21)	
2015	MA, RI, MK, NZ	1,294 (2)		2,162 (2)	3,202 (3)	2,107 (2)	2,031 (2)							10,796 (11)	
2016														0 (0)	
2017*	MA, RI		1,655 (2)	3,090 (4)	5,355 (5)	2,733 (3)	1,019 (1)	1,368 (1)	1,032 (1)	1,017 (1)	814 (1)	1,041 (1)	509 (1)	19,635 (21)	
2018*	MA, RI	1,043 (1)	1,118 (1)	1,688 (2)	1,960 (2)	1,065 (1)							6973 (7)		

*General and condensed surveys

TOTAL: 993,028 (104)

Wind Energy Areas: Massachusetts, Rhode Island, Muskeget Channel, Northeast Offshore Renewable Energy Innovation Zone

INDIVIDUAL WHALES SIGHTED PER MONTH (OBSERVERS AND VERTICAL CAMERA DETECTIONS)

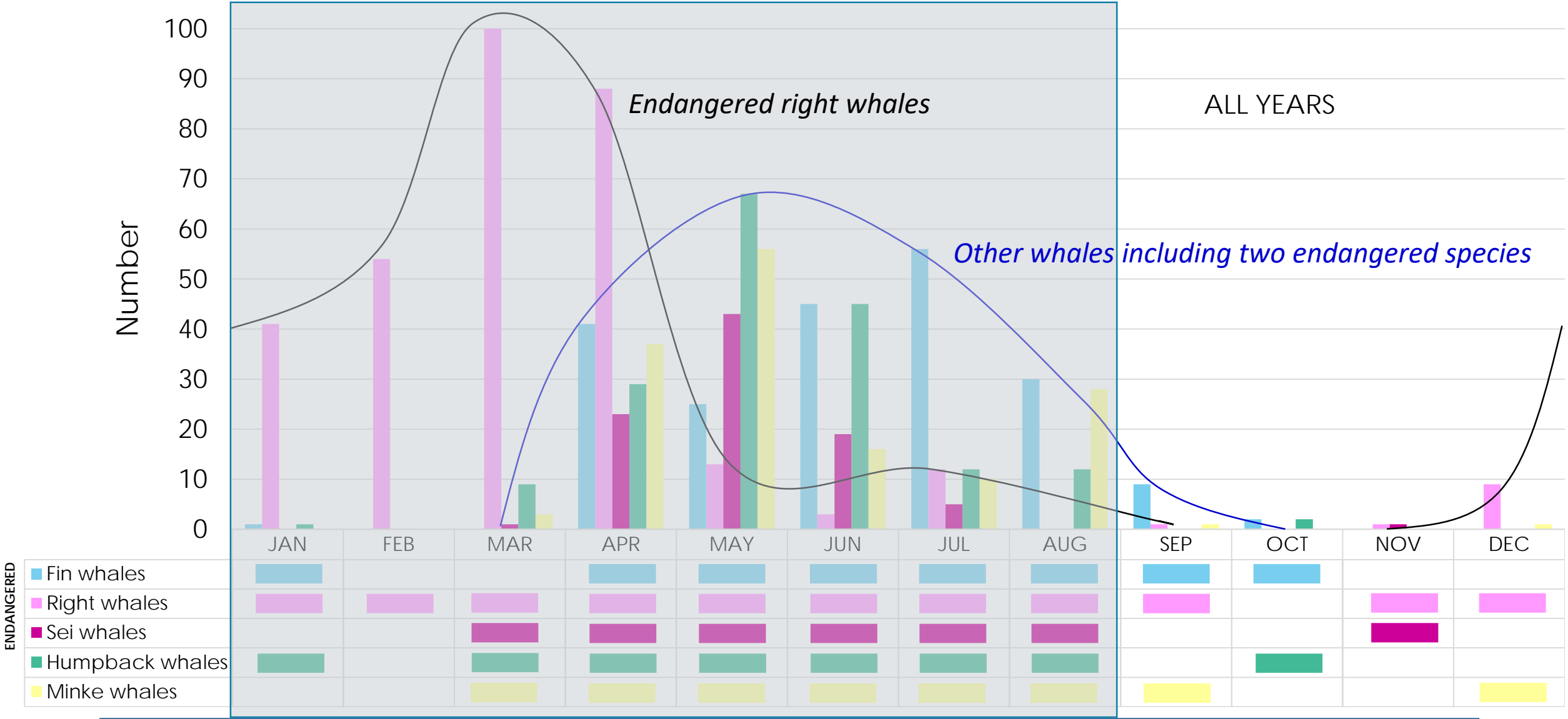

RIGHT WHALE SIGHTINGS IN THE MASSACHUSETTS AND RHODE ISLANDS WIND ENERGY AREAS

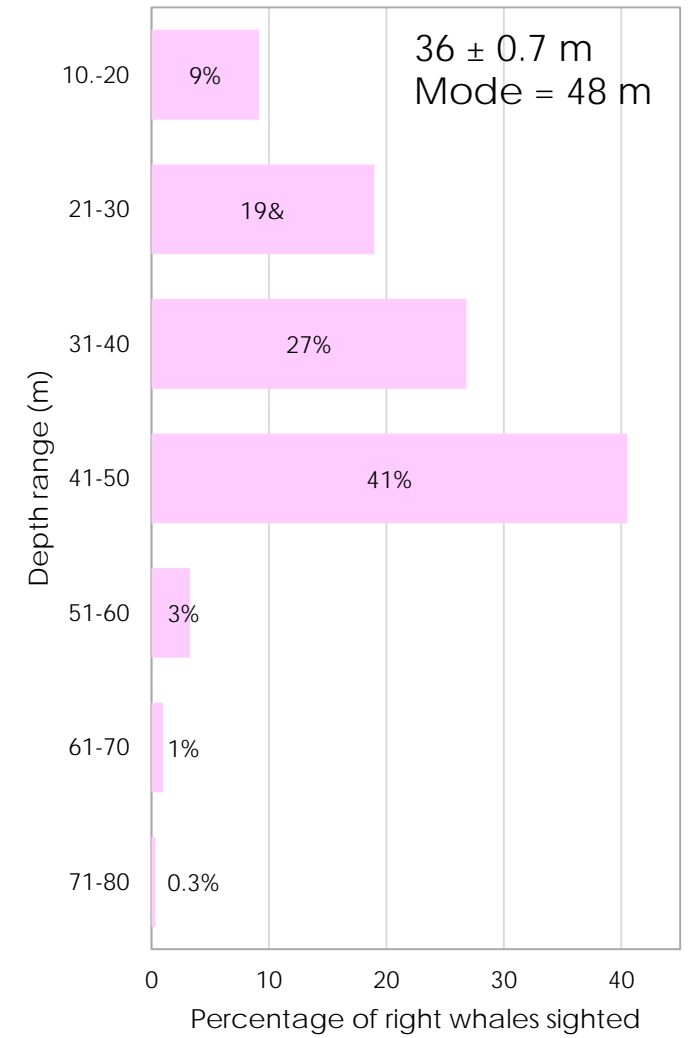
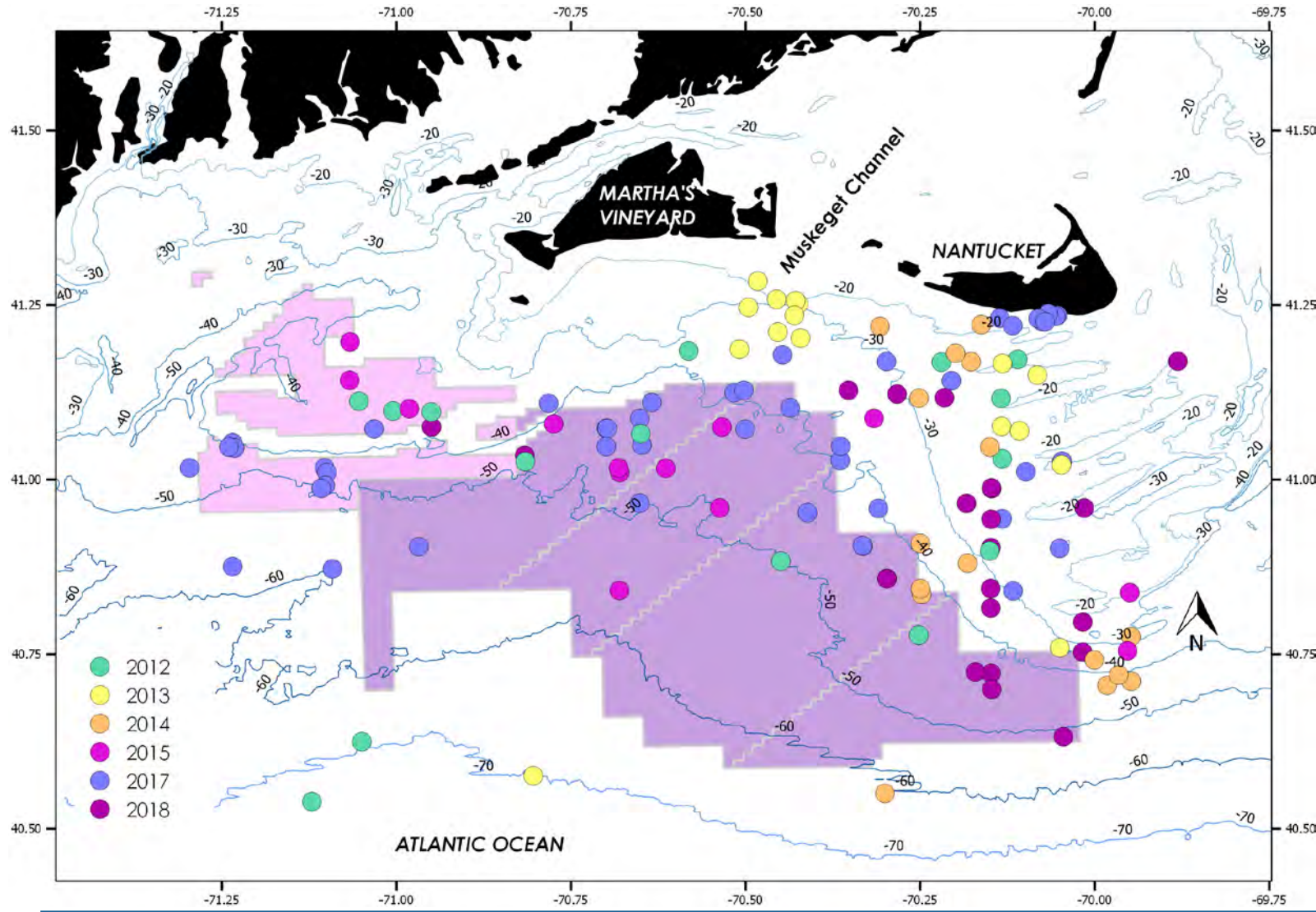

DEMOGRAPHICS* OF RIGHT WHALES SIGHTED (ALL YEARS)

	N	%	%		
			ADULT	JUVENILE	UNKNOWN
MALE	87	55	62	46	0
FEMALE	58	37	35	43	17
UNKNOWN	13	8	3	11	83
TOTALS	158	100	100	100	100

*2017-2018 are preliminary



CONCLUSIONS

- 5 species of baleen whales use the WEA including 3 endangered species*
- Fin whales*, sei whales*, humpback whales, and minke whales are sighted mainly from April to August.
- Right whales* are sighted most of the year but the peak months are from January to April.
- Right whales tend to be found in waters ranging from 40-50 m (35 ± 0.7 m, mode = 48 m).
- Highest proportion of identified right whales included adult males. However, the current sex ratio of the population is male-biased.

Passive Acoustic Monitoring for Marine Mammals in the Massachusetts and Rhode Island Wind Energy Areas

Aaron N. Rice, Jamey T. Tielens, Bobbi J. Estabrook,
Christopher W. Clark

Bioacoustics Research Program

Cornell Lab of Ornithology

Cornell University

Ithaca, NY 14850

Email: arice@cornell.edu

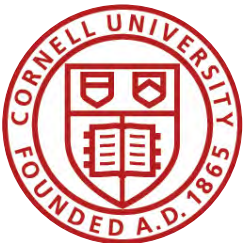

Study Objectives

- Document occurrence of focal baleen whale species using passive acoustic monitoring approaches
 - North Atlantic Right Whales, Fin Whales, Minke Whales, Humpback Whales, Blue Whales
- Quantify interannual variability
- Identify spatial trends
- Characterize ambient noise conditions

Recorder Locations

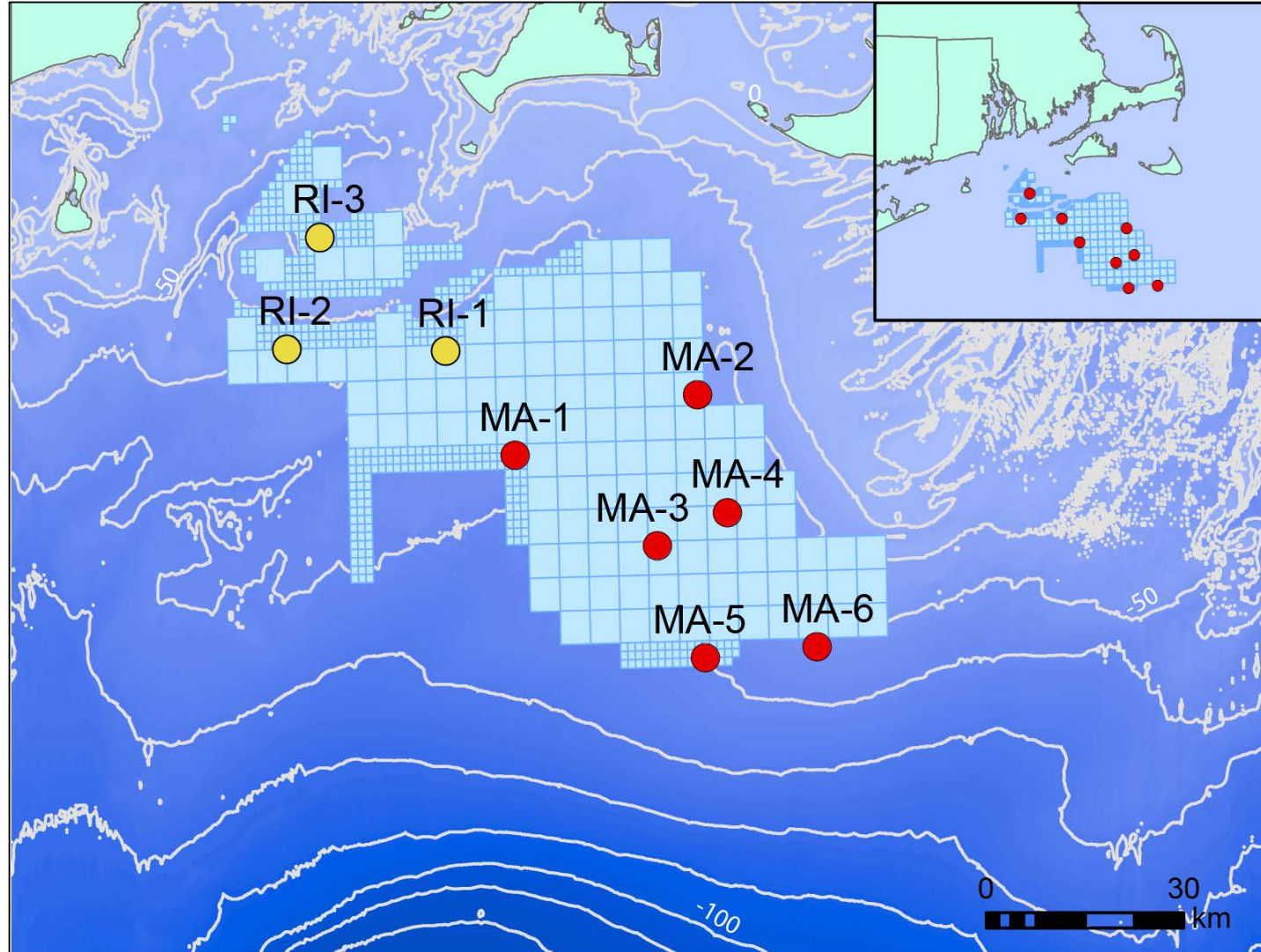

Recording Units

Marine Autonomous Recording Unit (MARU)

- Archival recorder
- Records for up to ~ 4 months
- Sampling rates up to 64 kHz, typically 2 kHz
- Can be used for presence/absence or deployed in arrays for localization

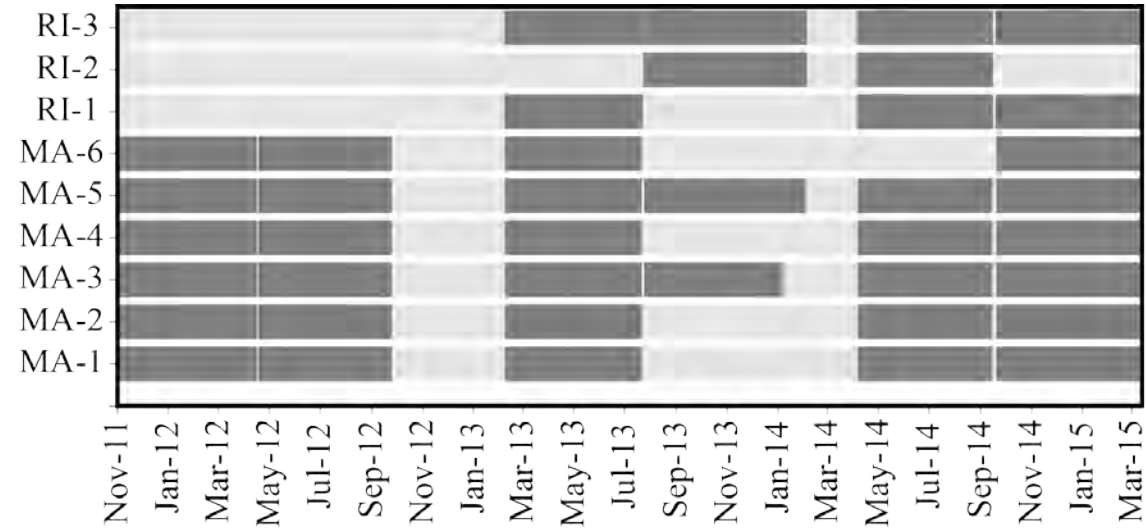

Species of Interest

North Atlantic right whale

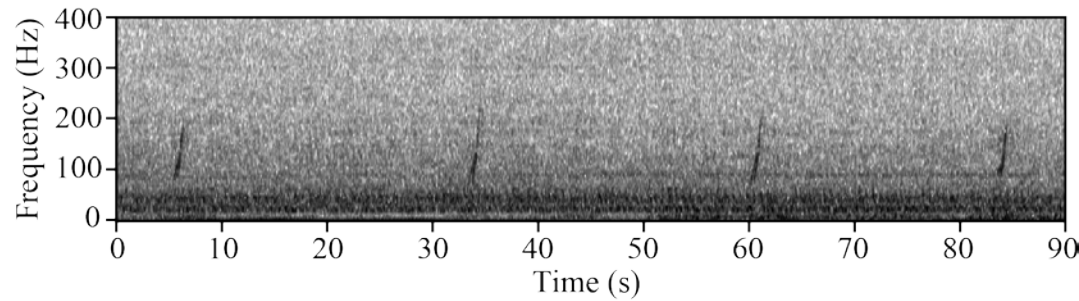

Minke whale

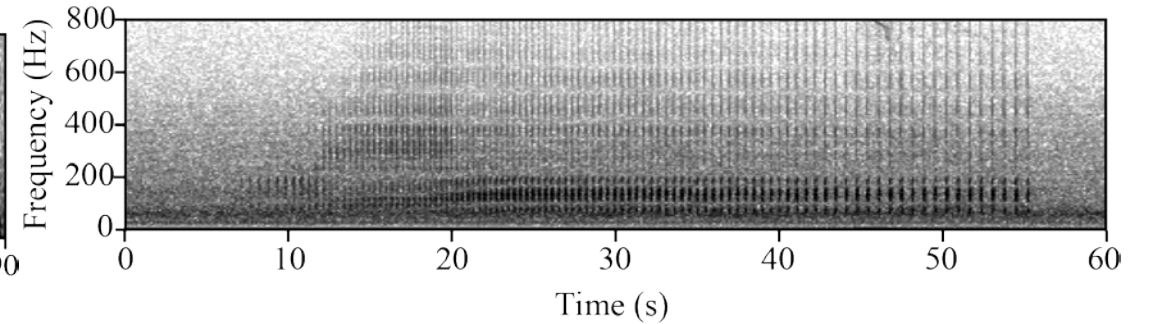

Fin whale

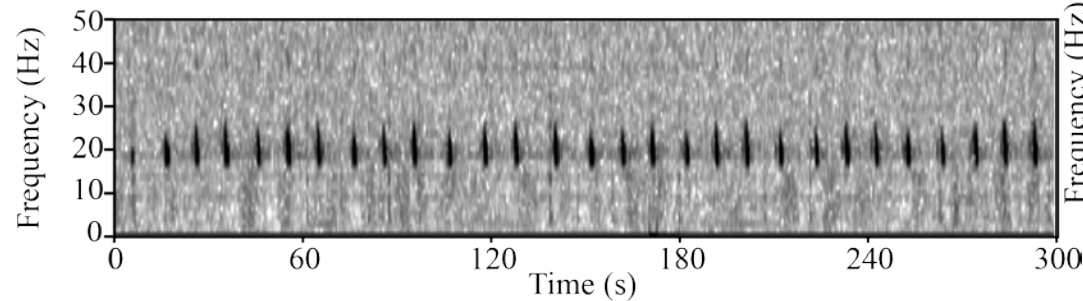

Blue whale

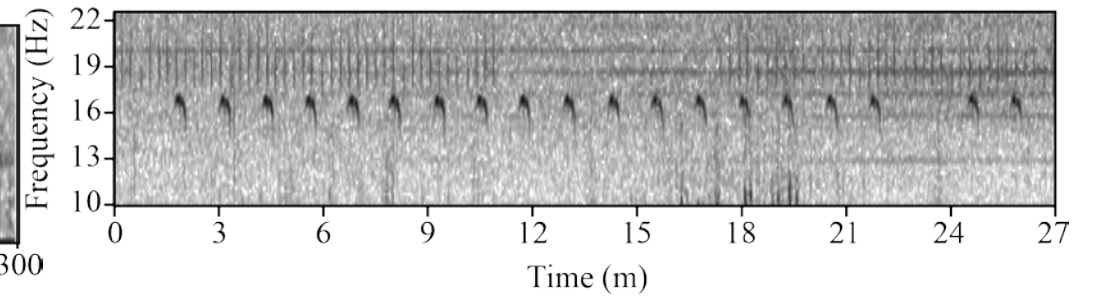

Humpback whale (song)

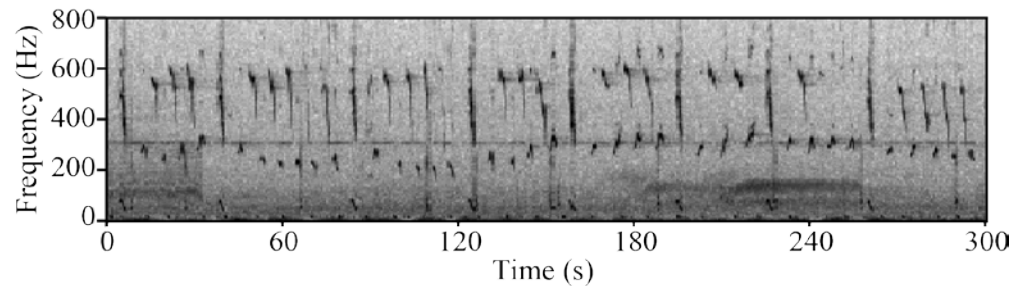

Humpback whale (social sounds)

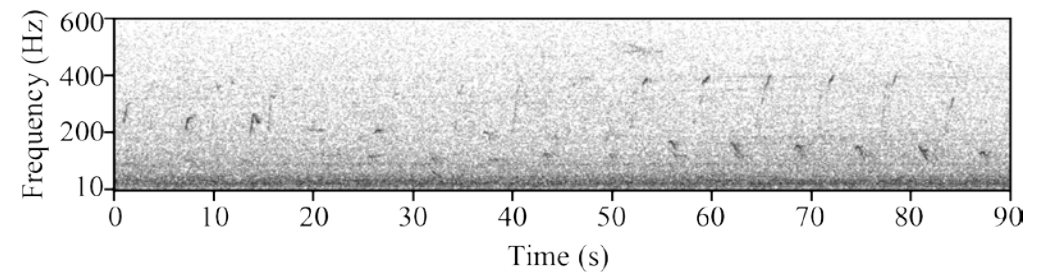

Blue Whale Presence

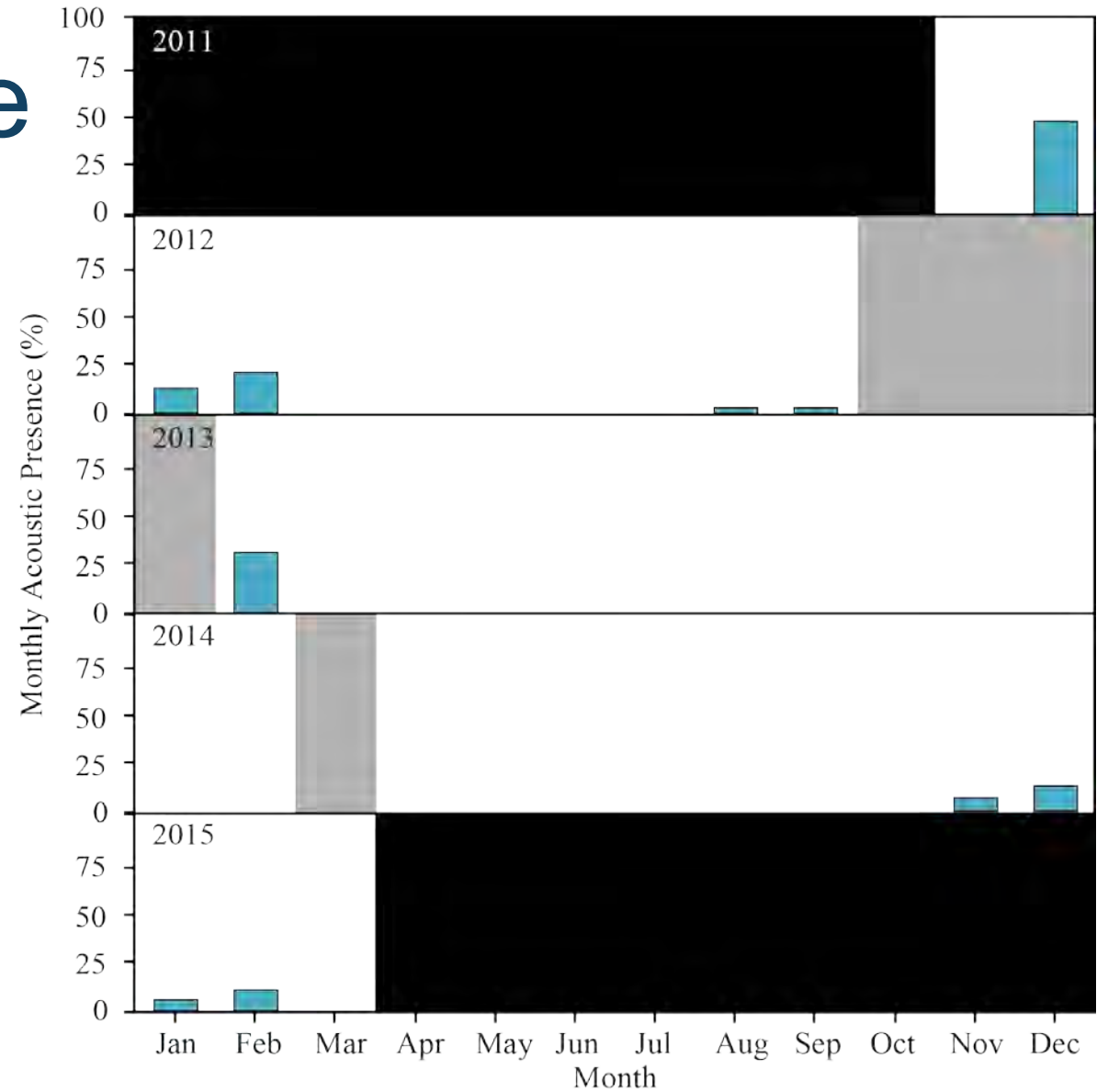

Fin Whale Presence

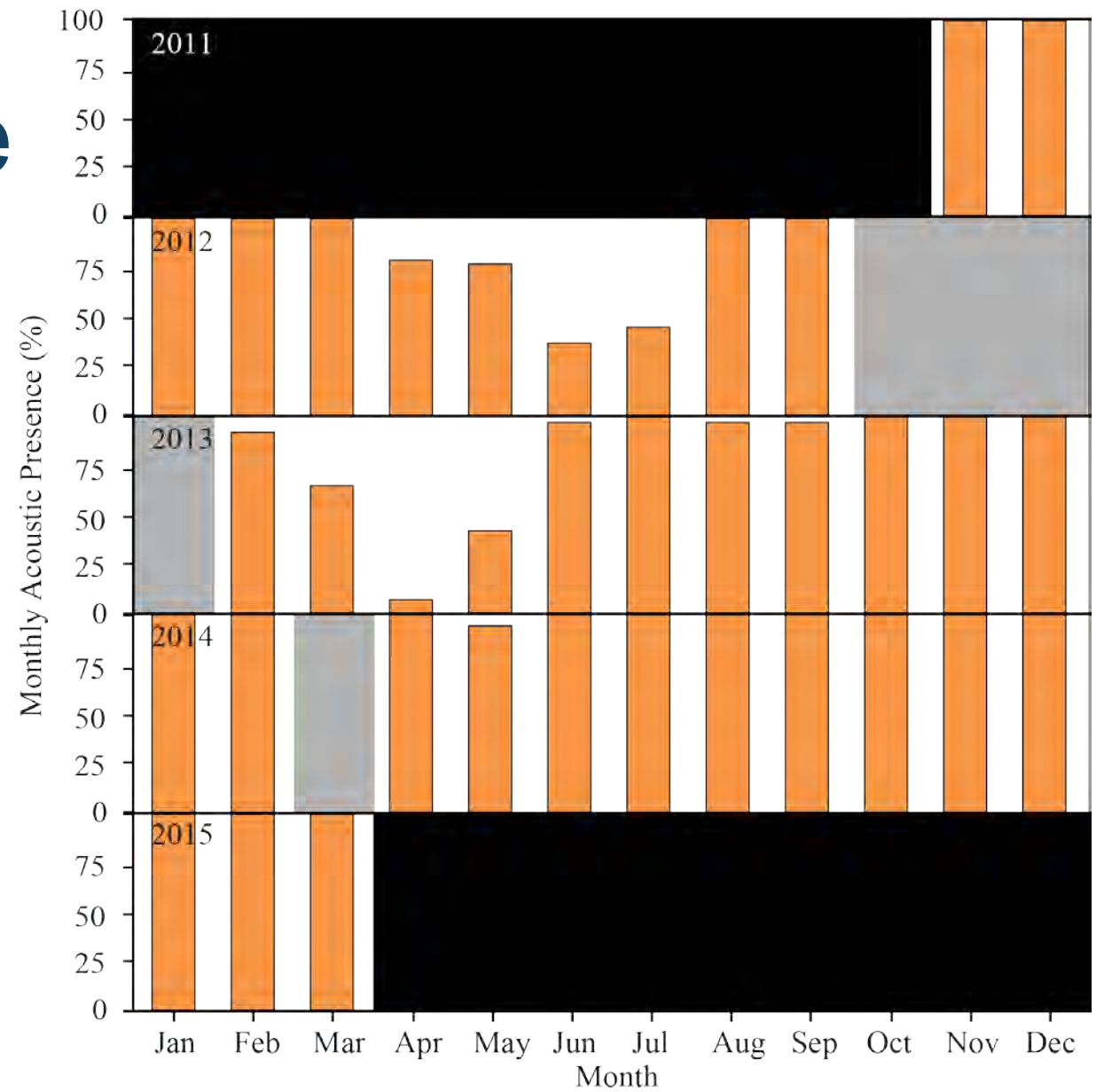

Humpback Whale Presence

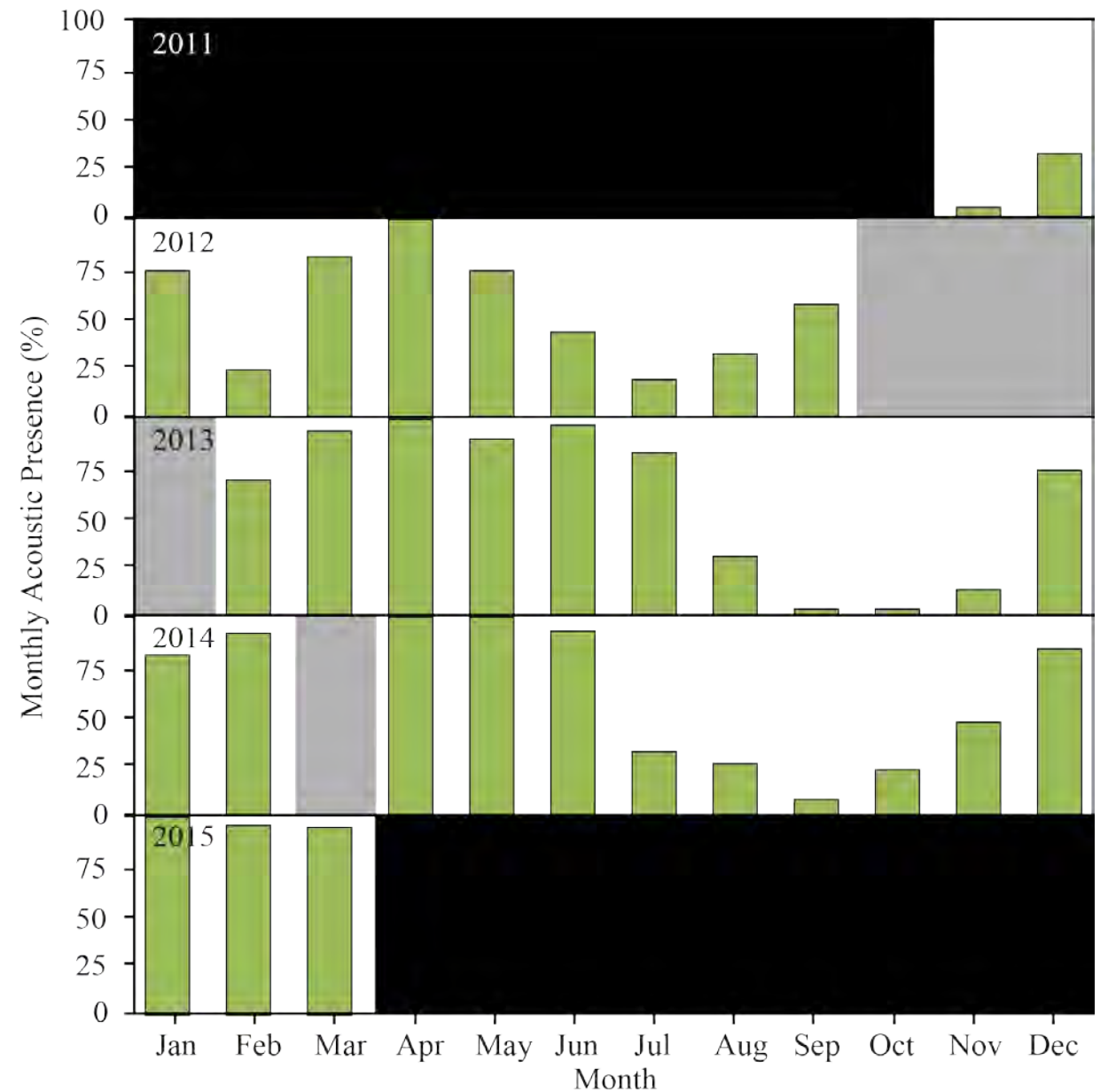

Minke Whale Presence

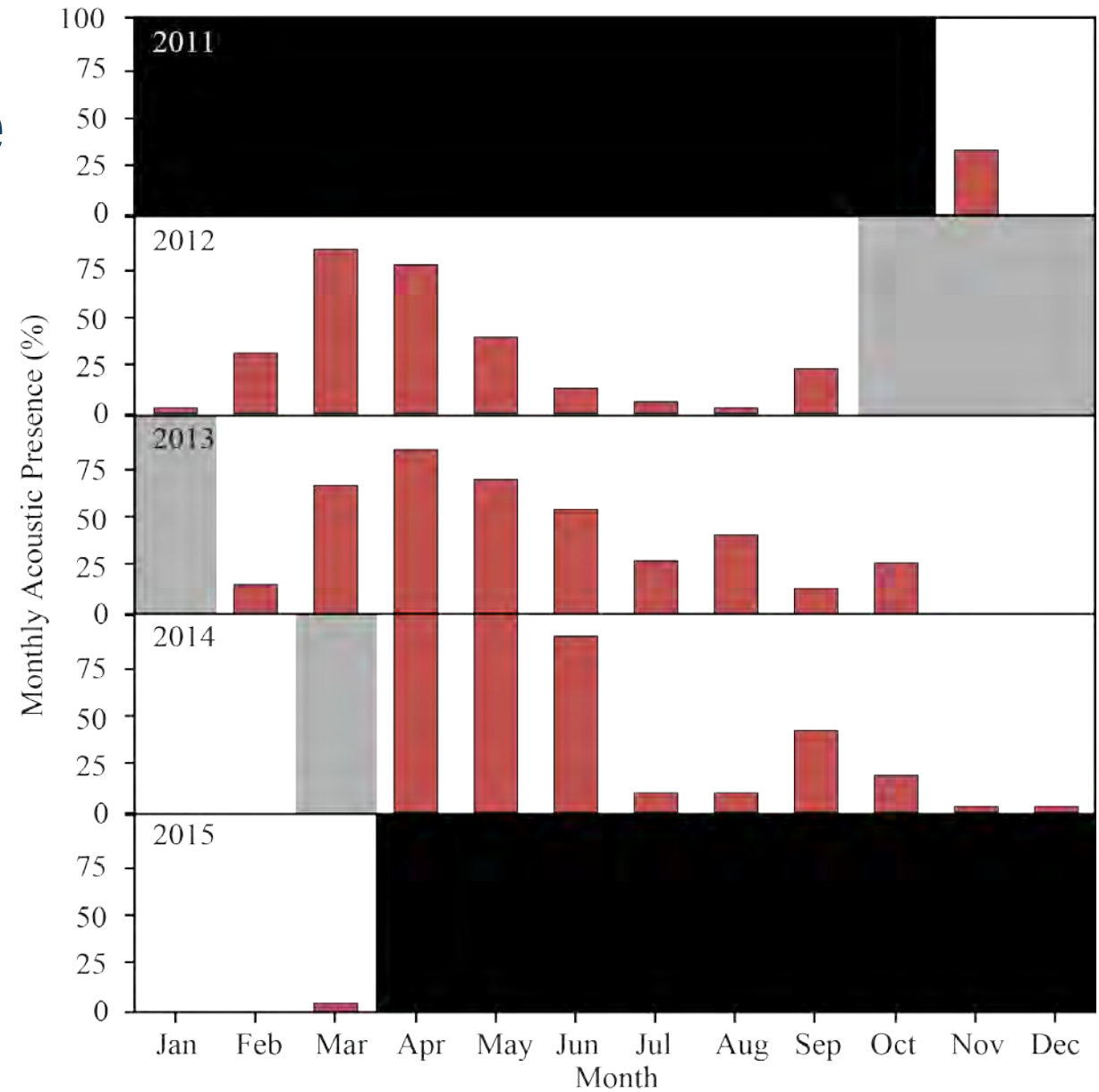

Right Whale Presence

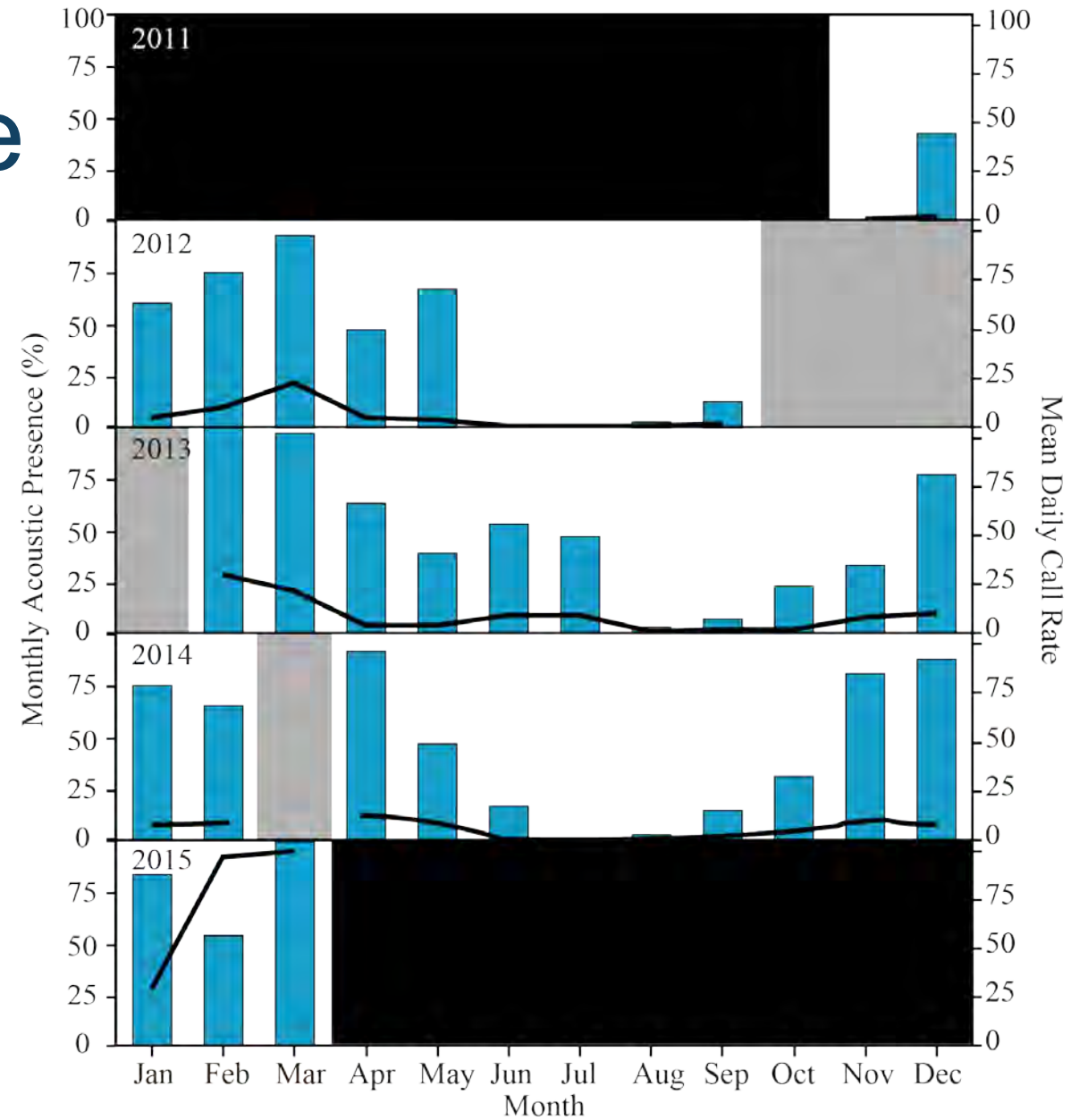

Right Whale Spatial Patterns

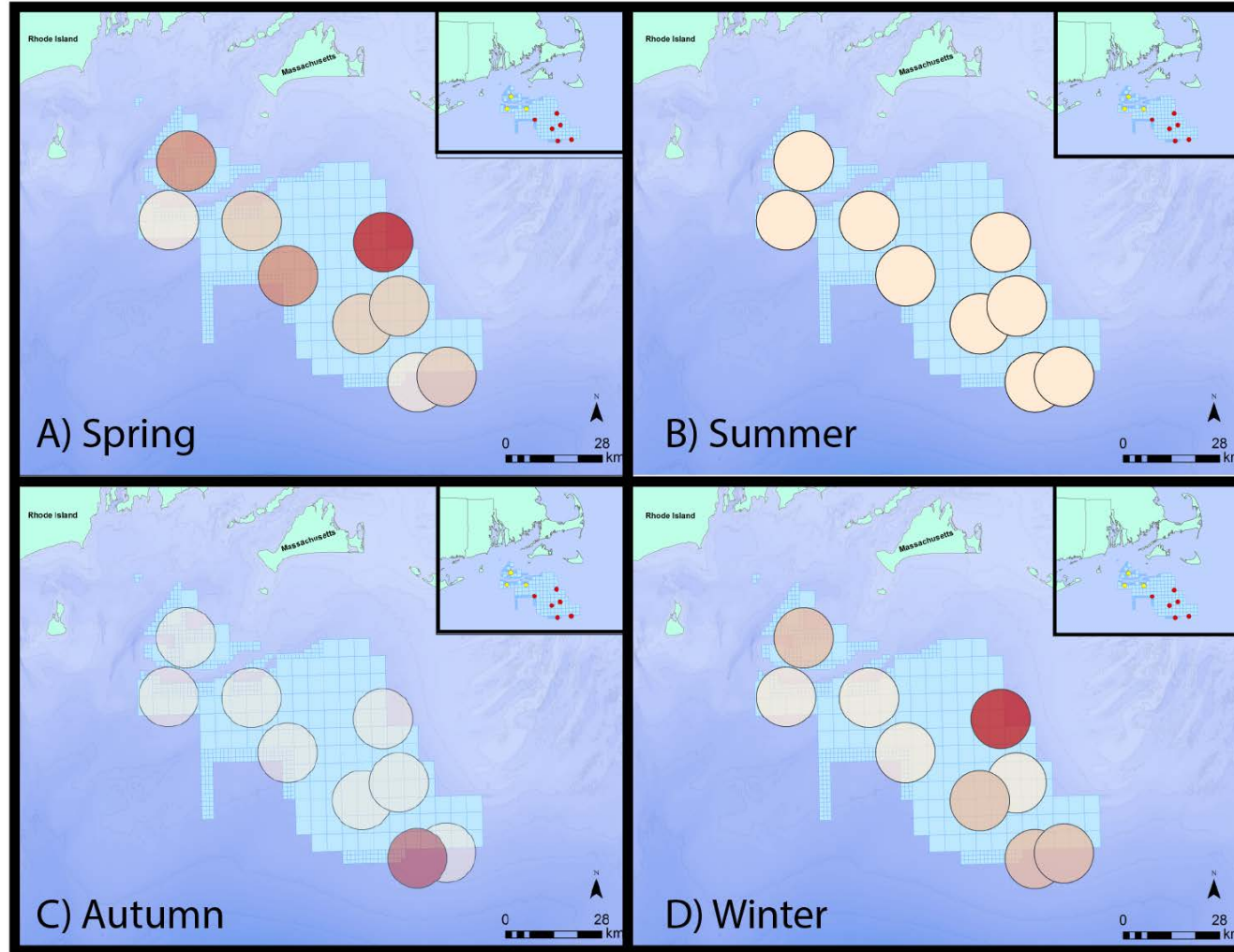

Seasonal Trends

Blue

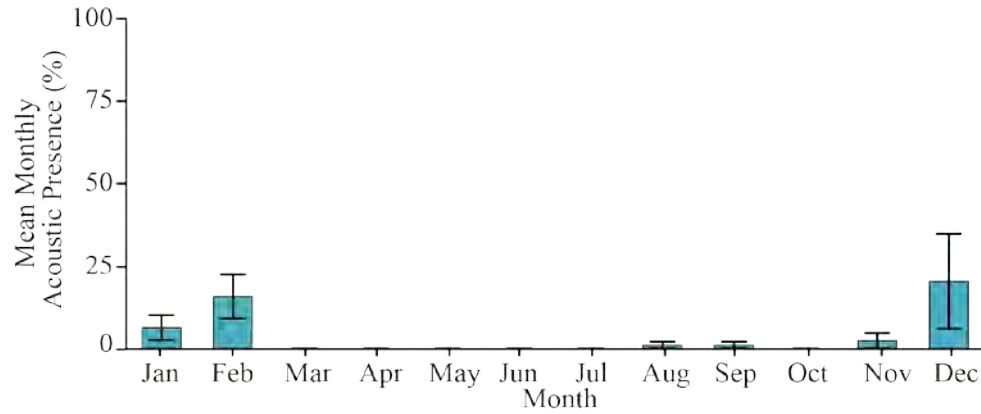

Fin

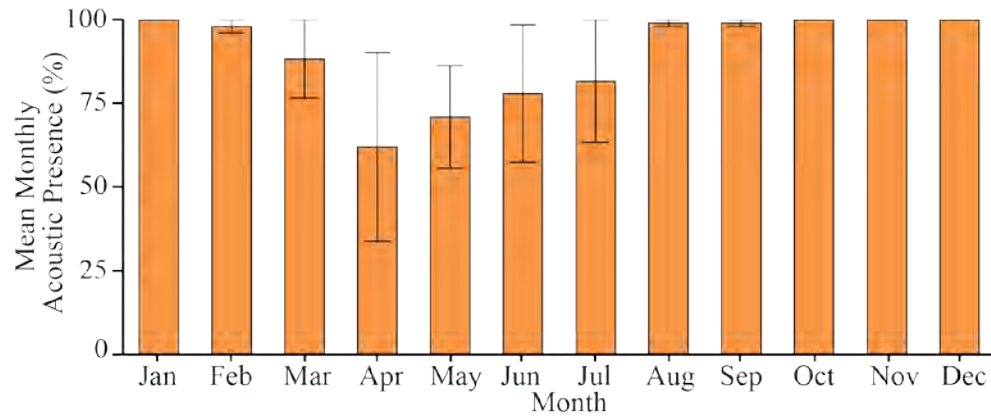

Humpback

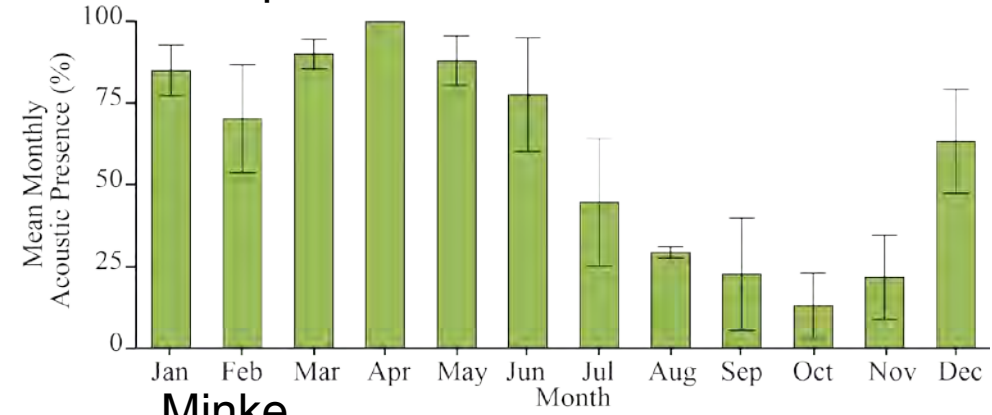

Minke

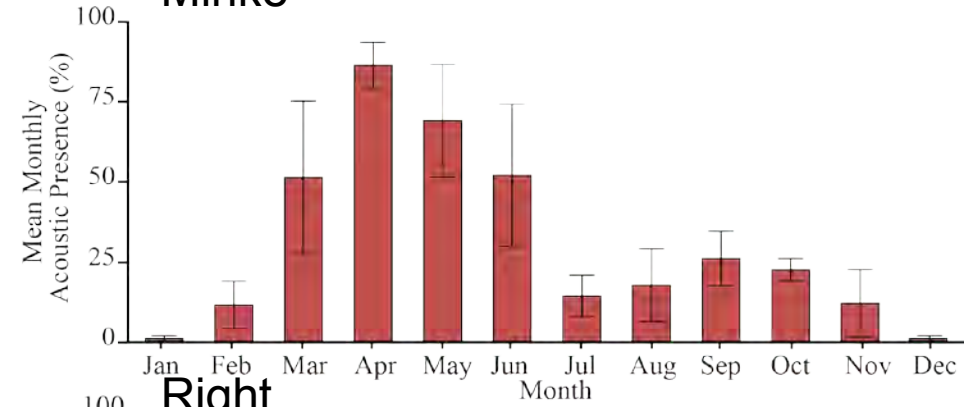

Right

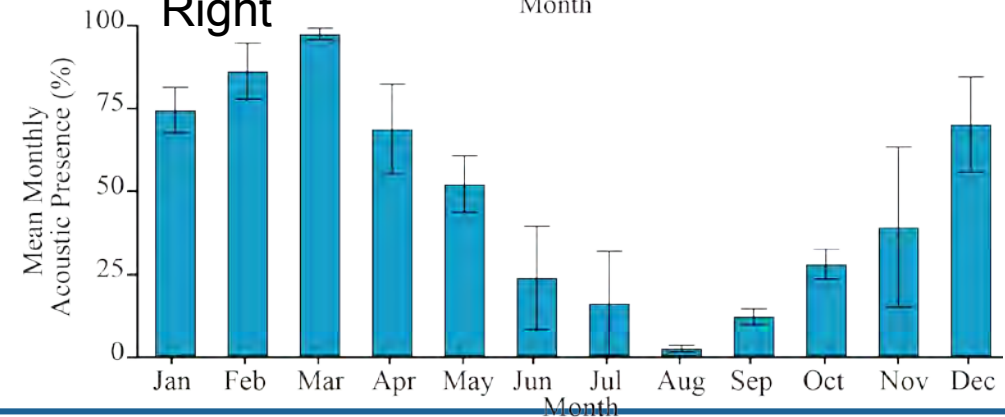

Simultaneous Presence of Multiple Focal Species

(16 March 2012)

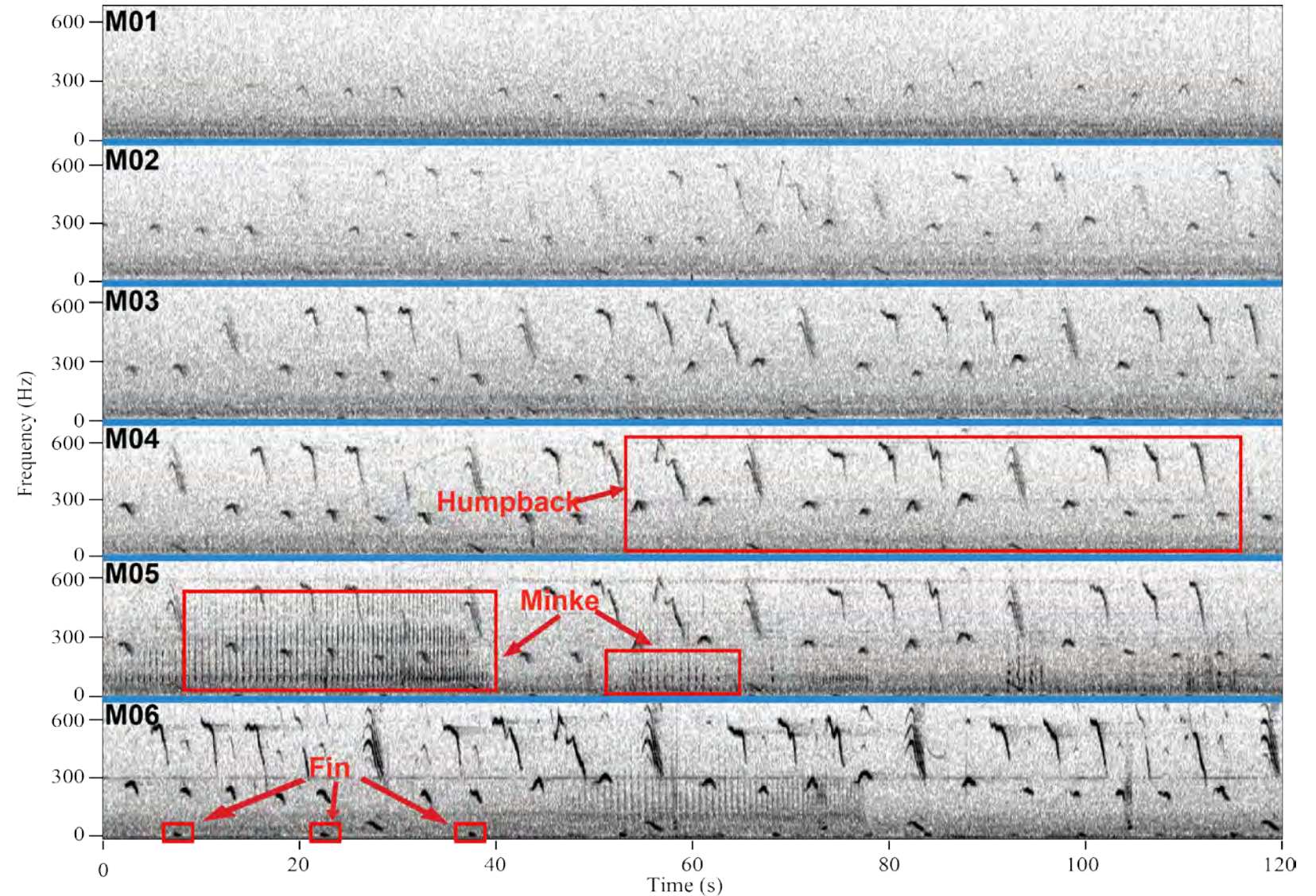

Ambient Noise

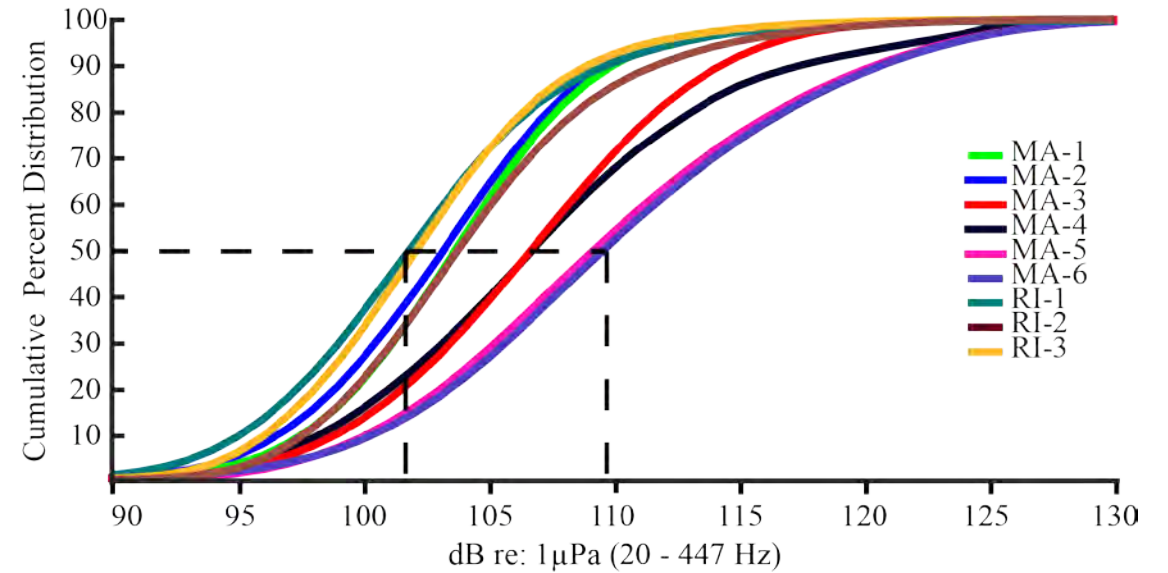
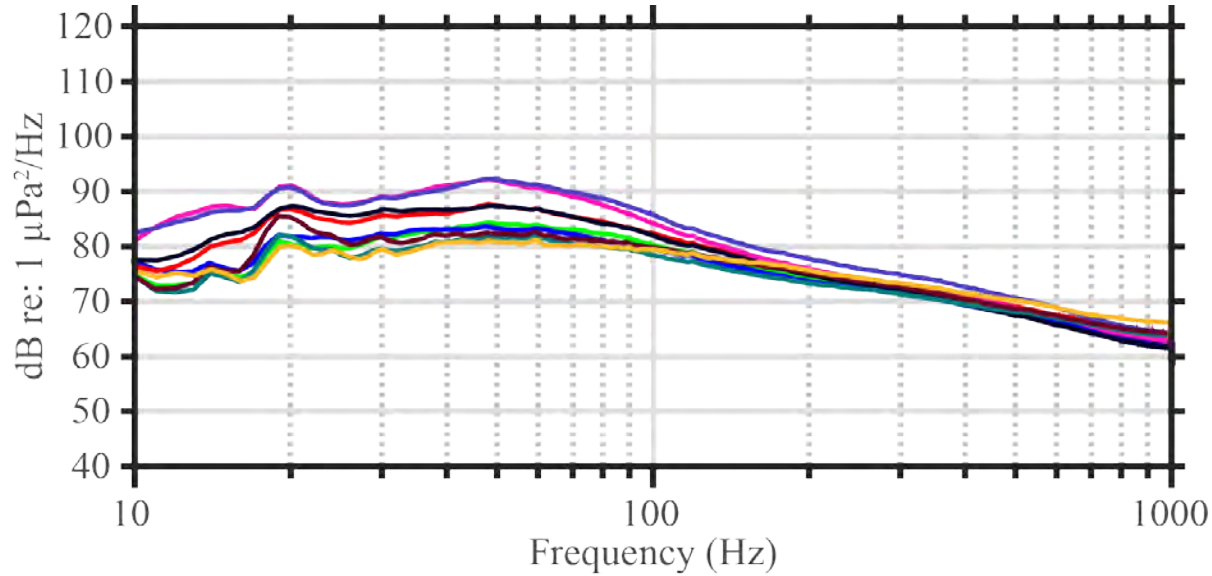

Summary

- Lots of whale activity in nearly all months of the year
 - Clear seasonal trends in blue, humpback, minke right whales
 - High interannual variability for humpback, minke, and right whales
- Right whales distributed throughout wind planning area, but highest during spring, fall, and winter
- Ambient noise shows that this area is significantly quieter than other areas in the Mid-Atlantic

Right whale habitat in the Massachusetts Wind Energy Area

Mark Baumgartner

Woods Hole Oceanographic Institution

Motivation

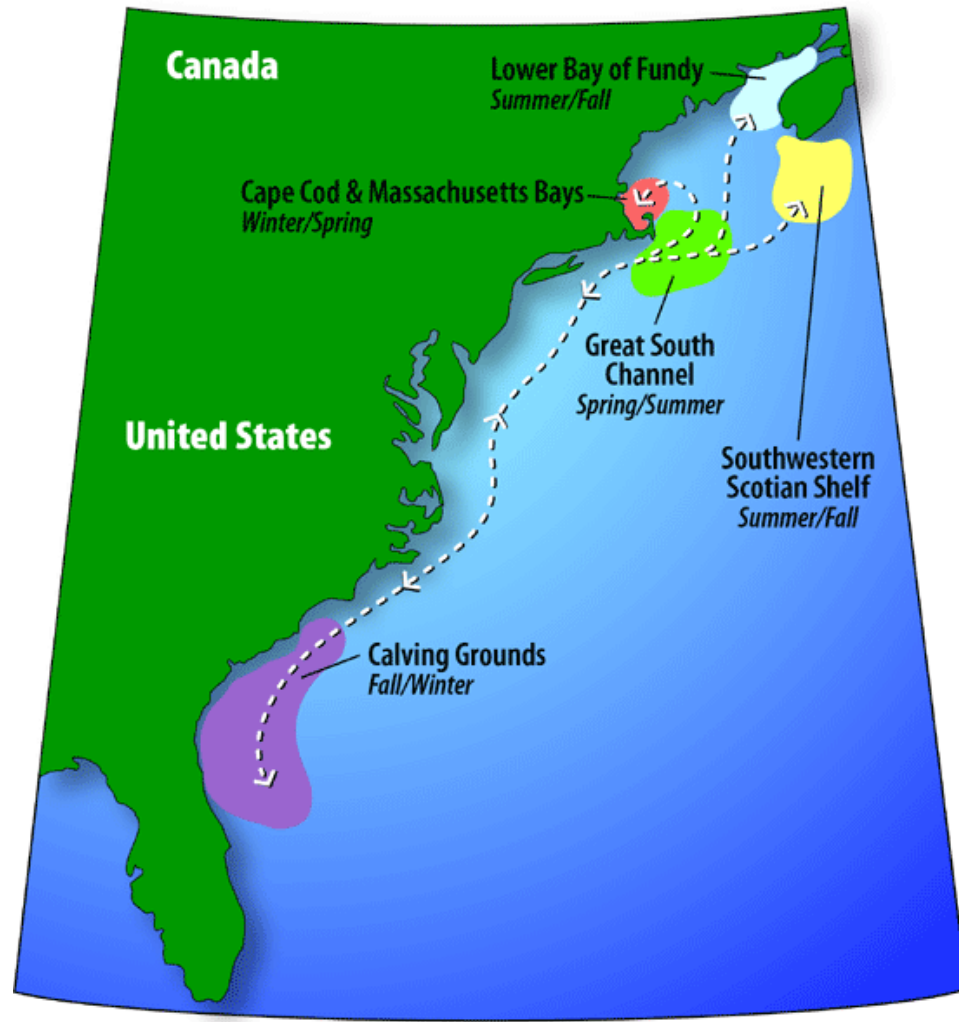

Why do right whales visit the MWEA?

For most northern habitats, right whale movements are governed largely by food availability.

Likely the same in the MWEA.

Study design

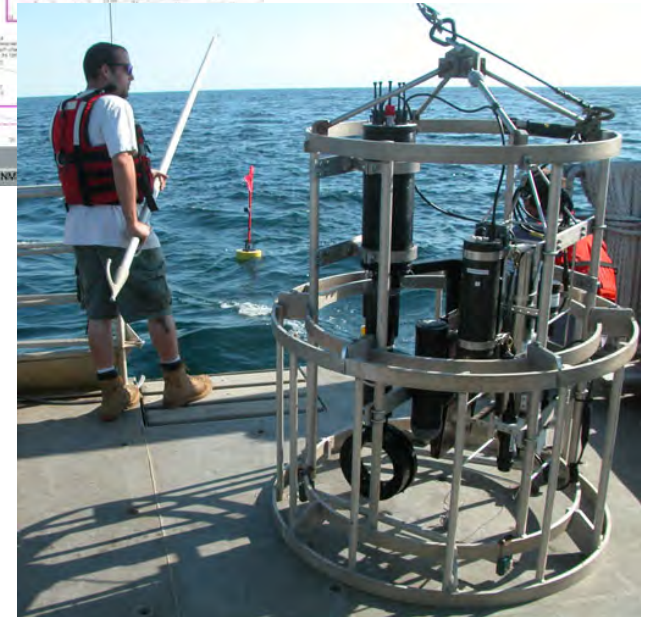
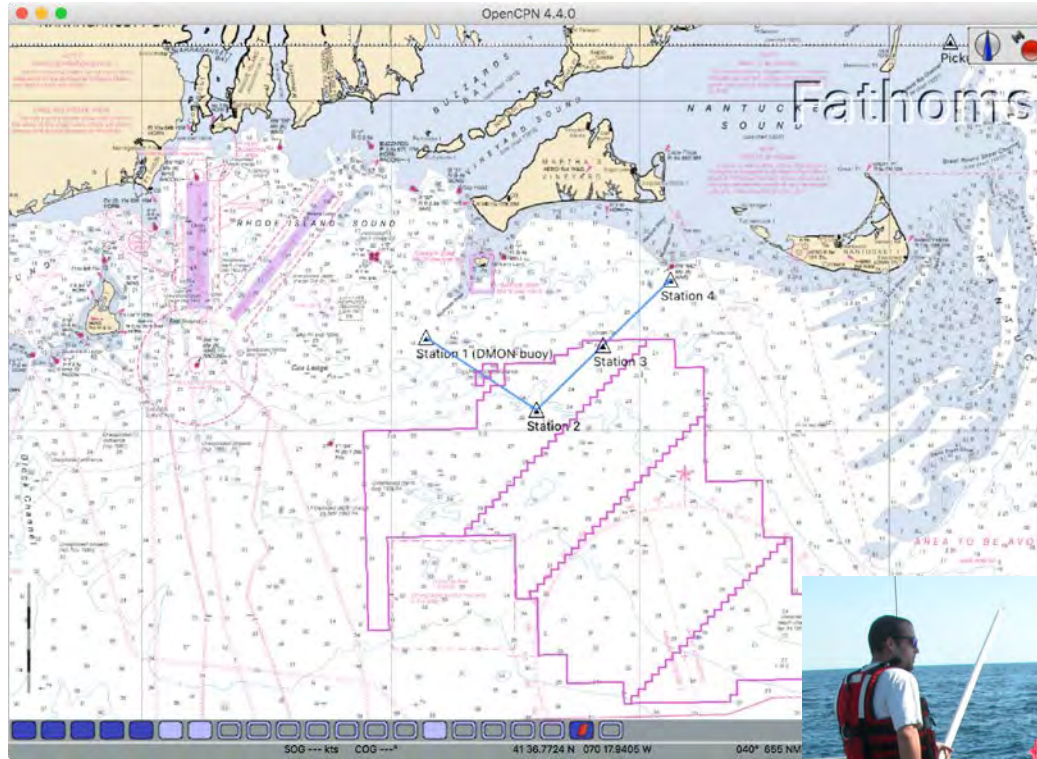
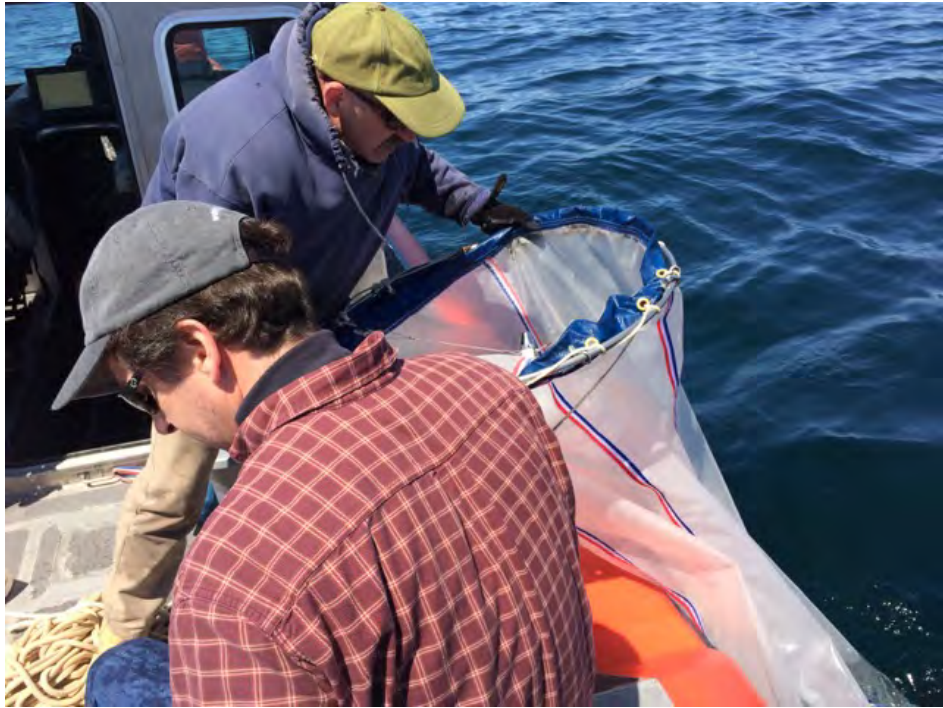

- Zooplankton sampling
- Oceanographic conditions

- Sample at standard stations
- Sample near whales

March 6

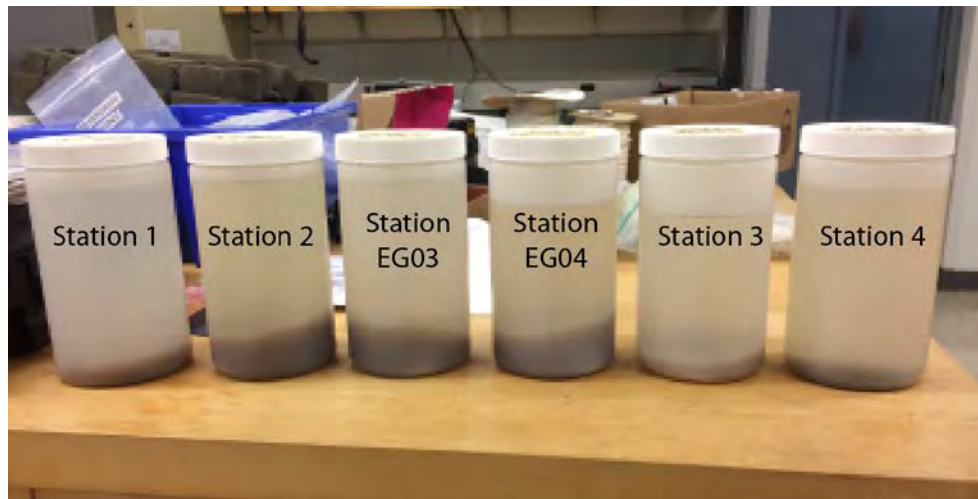

- Samples dominated by *Centropages typicus*
- Samples near whales contain higher biomass



March 6

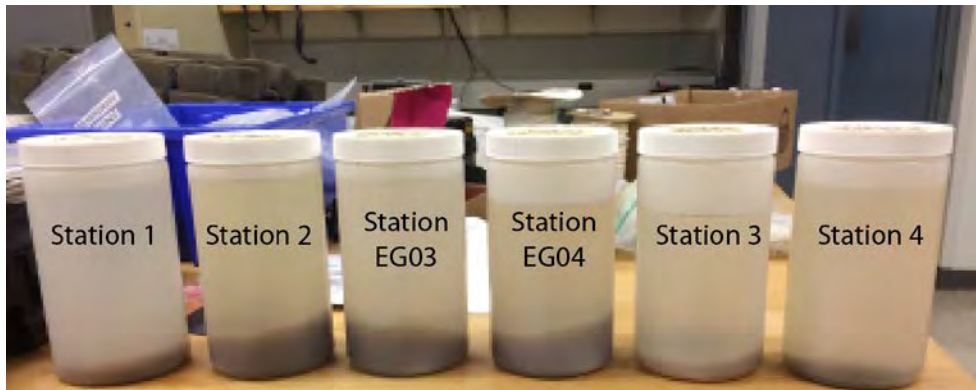

April 10

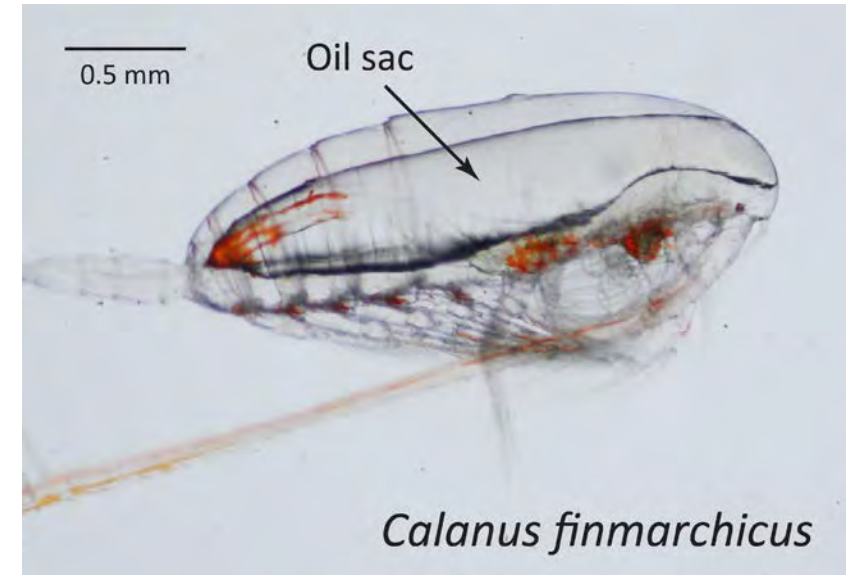
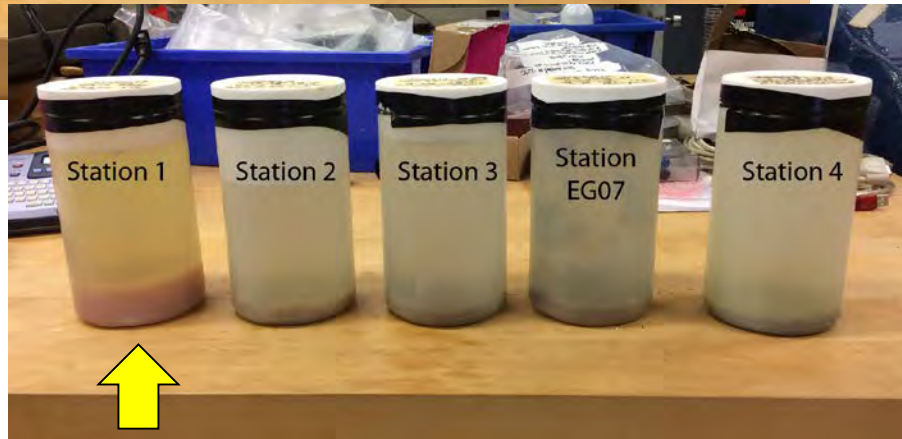

- Spring bloom underway
- Biomass generally low
- Appearance of *Calanus finmarchicus*

March 6

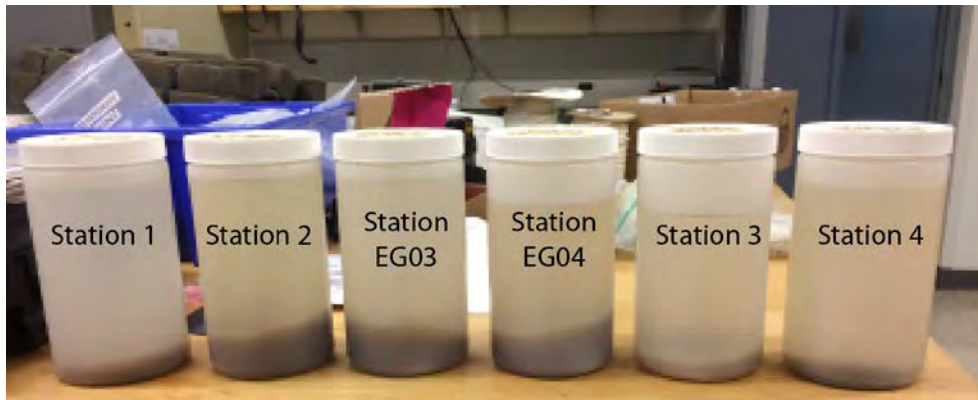

April 10

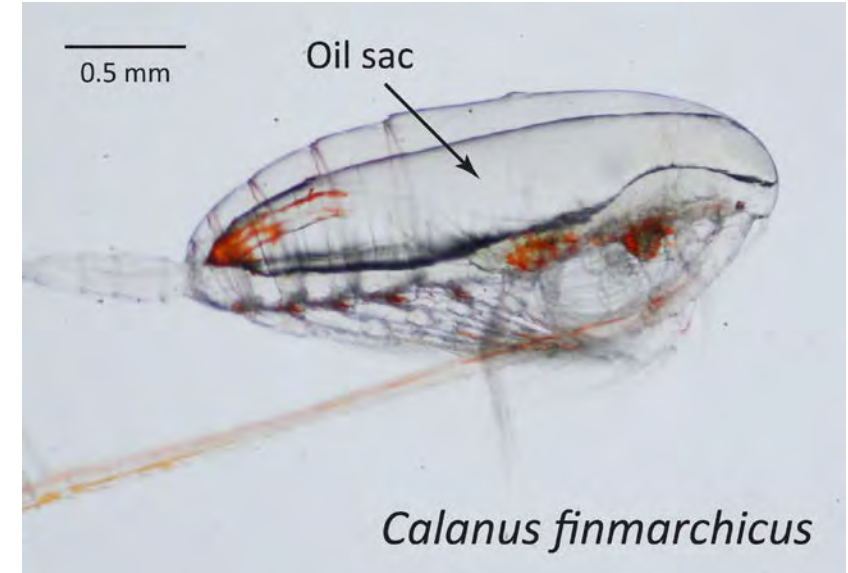
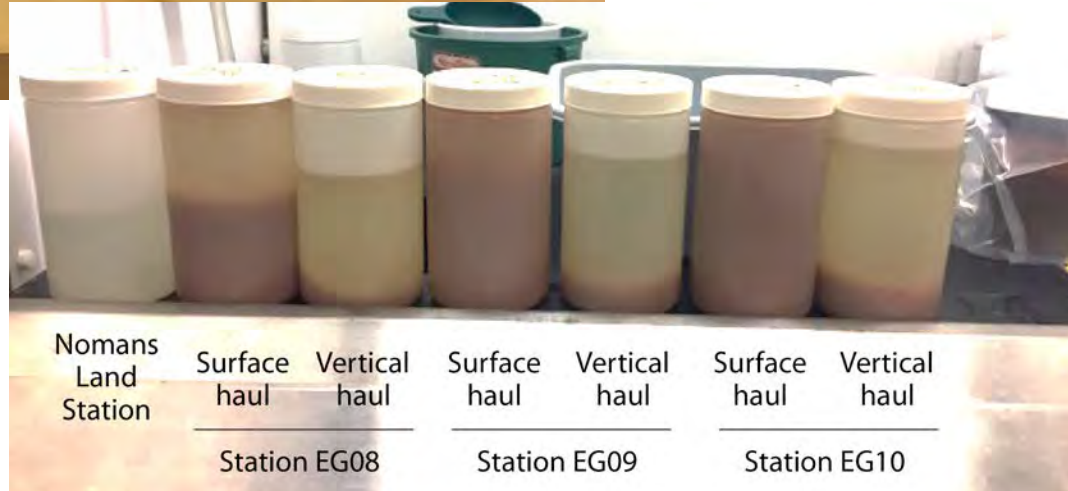
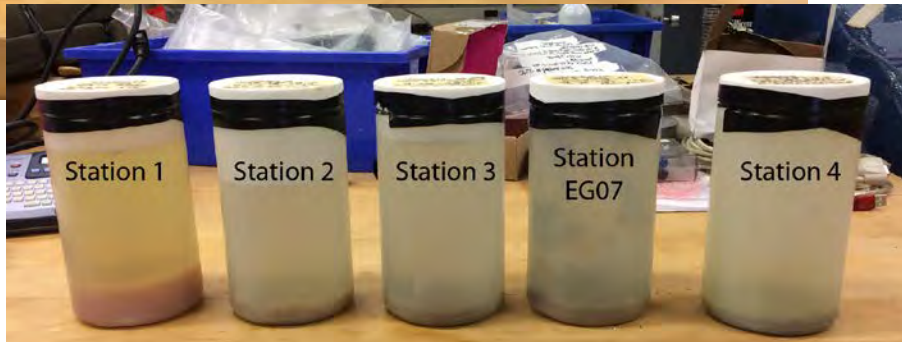

May 4

Results

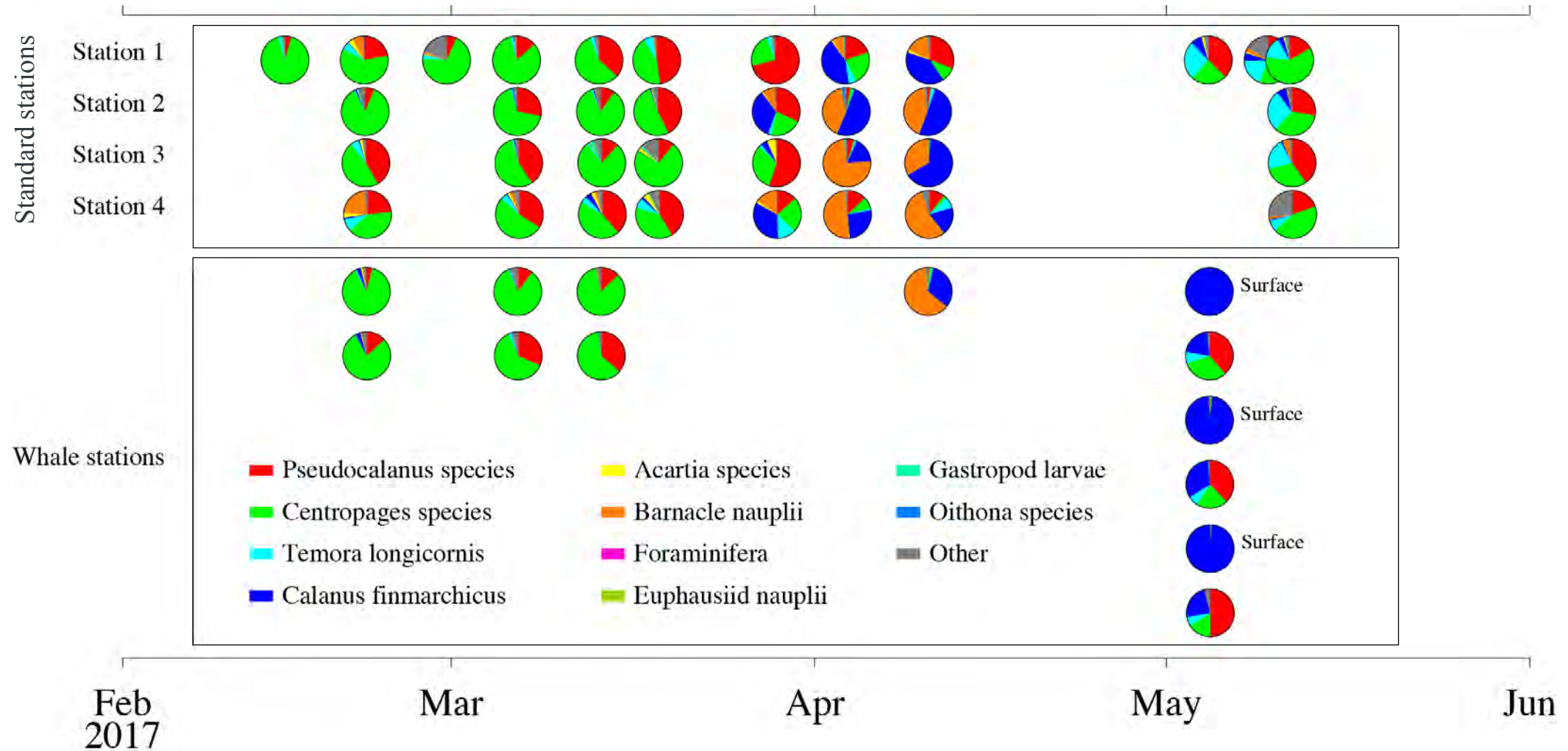

Results



Temperature

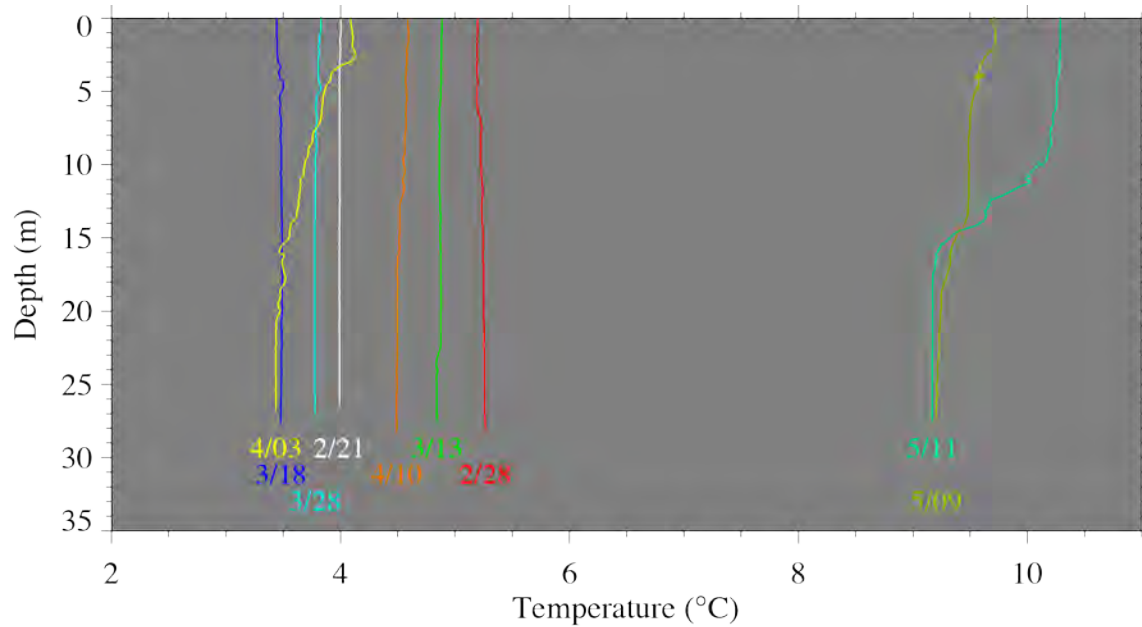

Salinity

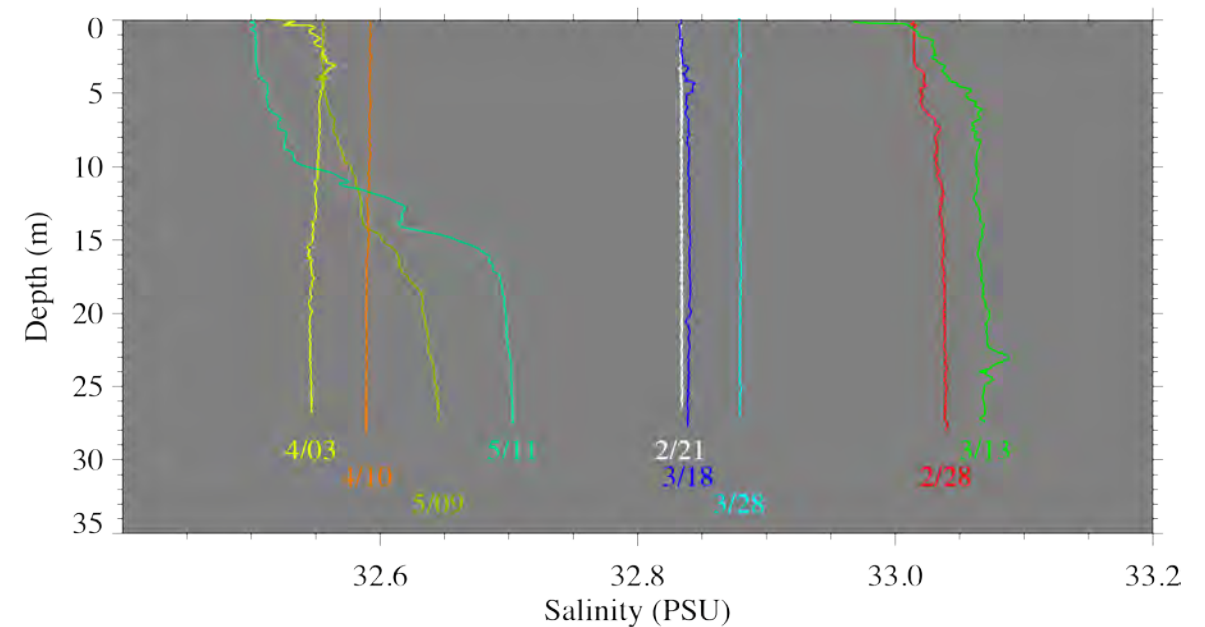

- Well-mixed for most of the spring
- Stratification begins mid-April

Conclusions



- Seasonal progression of zooplankton species very similar to Cape Cod Bay
- Source of *Calanus finmarchicus* unknown, but likely from Gulf of Maine via Nantucket Shoals
- Right whales feeding on *Centropages typicus* and possibly amphipods in late winter and early spring, then transition to *Calanus finmarchicus* by mid-spring

Future work



- Verify seasonal pattern
- Characterize year-to-year changes in species assemblage and timing
- Determine from where *Calanus finmarchicus* in MWEA originate
- Will variations in *Calanus* abundance/timing be related to changes taking place in the Gulf of Maine?

Potential analytical and statistical approaches for testing hypotheses

Len Thomas



CREEM

Centre for Research into Ecological
and Environmental Modelling



University of
St Andrews

What is the question?

- Hypotheses can be boiled down to:

Do wind farms cause a change in some parameter of interest for a species of concern?



Detecting change in a parameter of interest

Temporal change

- Long-term: trend
- Short-term: sudden change, relative to baseline variability

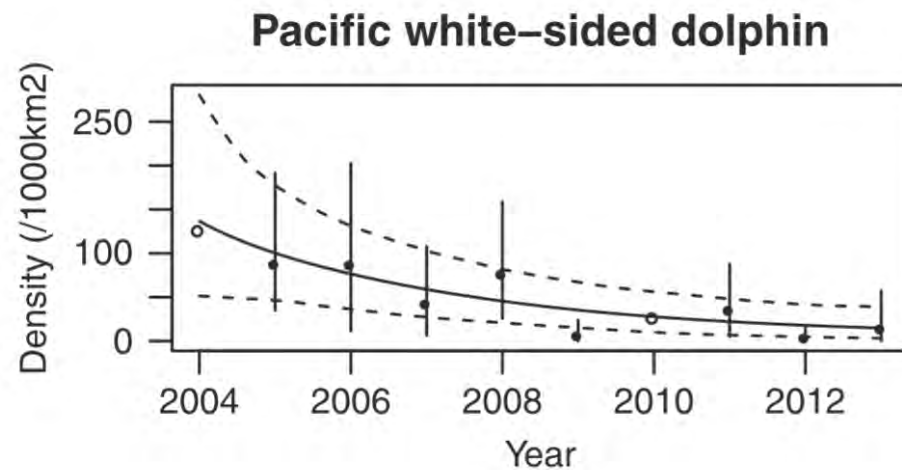

Campbell et al. (2015) Deep Sea Research

Durant et al. (2011) J. Appl. Ecol.

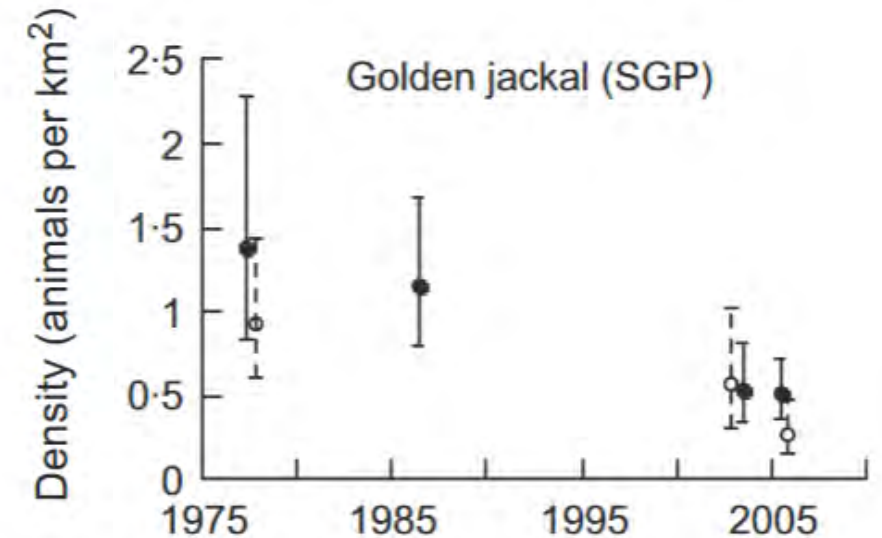
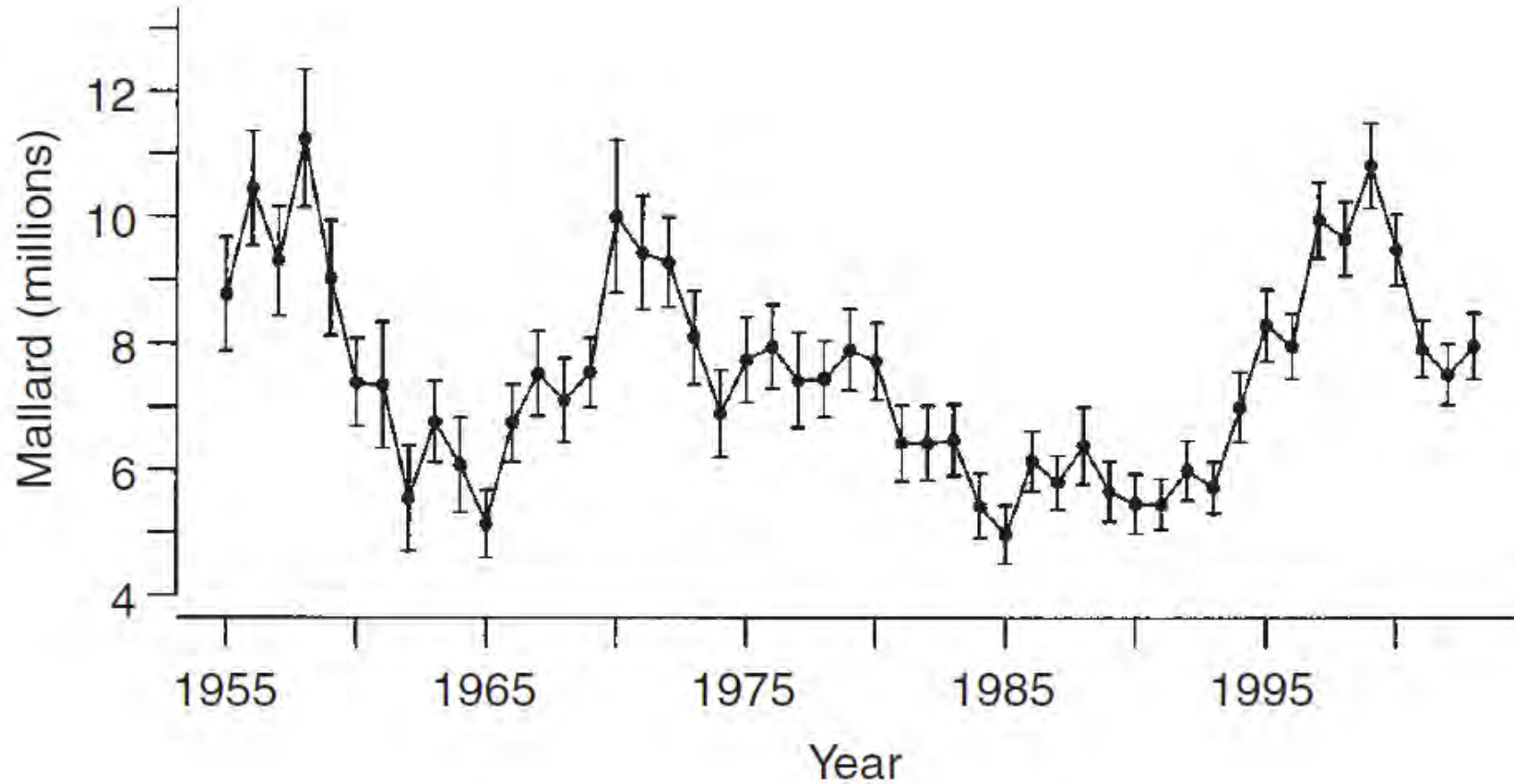

Table 2. Analysis of annual trends and abrupt change using analytical and bootstrap approaches

Species	Analytic annual trend					Bootstrap annual trend				Abrupt change in last survey			
	r%	Lower C.L.	Upper C.L.	SD	Trend P	r%	Lower C.L.	Upper C.L.	SD	r%	Lower C.L.	Upper C.L.	SD
Spotted hyaena	-0.52	-0.97	-0.05	0.24	0.03	-0.50	-1.64	0.72	0.60	-13.40	-40.42	14.12	14.54
Lion	-3.06	-1.57	0.90	0.63	0.57	-0.30	-4.20	4.59	2.25	16.47	-60.32	205.60	72.28
Cheetah	-1.21	-3.24	0.90	1.07	0.25	-1.09	-4.87	3.39	2.10	-25.72	-65.26	47.96	29.16
Golden jackal	-3.09	-3.76	-2.43	0.36	0.00	-3.09	-4.47	-1.71	0.70	-49.84	-60.65	-35.48	7.23
Black-backed jackal	-3.83	-5.41	-2.23	0.86	0.00	-3.87	-6.53	-1.19	1.35	-10.70	-55.25	45.20	27.47
Side-striped jackal	6.79	0.86	16.06	3.32	0.06	9.96	-0.38	45.54	13.15	120.86	-87.21	793.39	213.81
Bat-eared fox	-3.38	-5.03	-1.69	0.89	0.00	-3.54	-6.93	-0.09	1.74	-43.61	-89.14	20.63	30.91

r% is percentage annual growth rate and significant trends ($P < 0.05$) are in bold.

Trend: what is “long-term”?



Thomas et al. (2004) Advanced Distance Sampling Ch5

What is long-term?

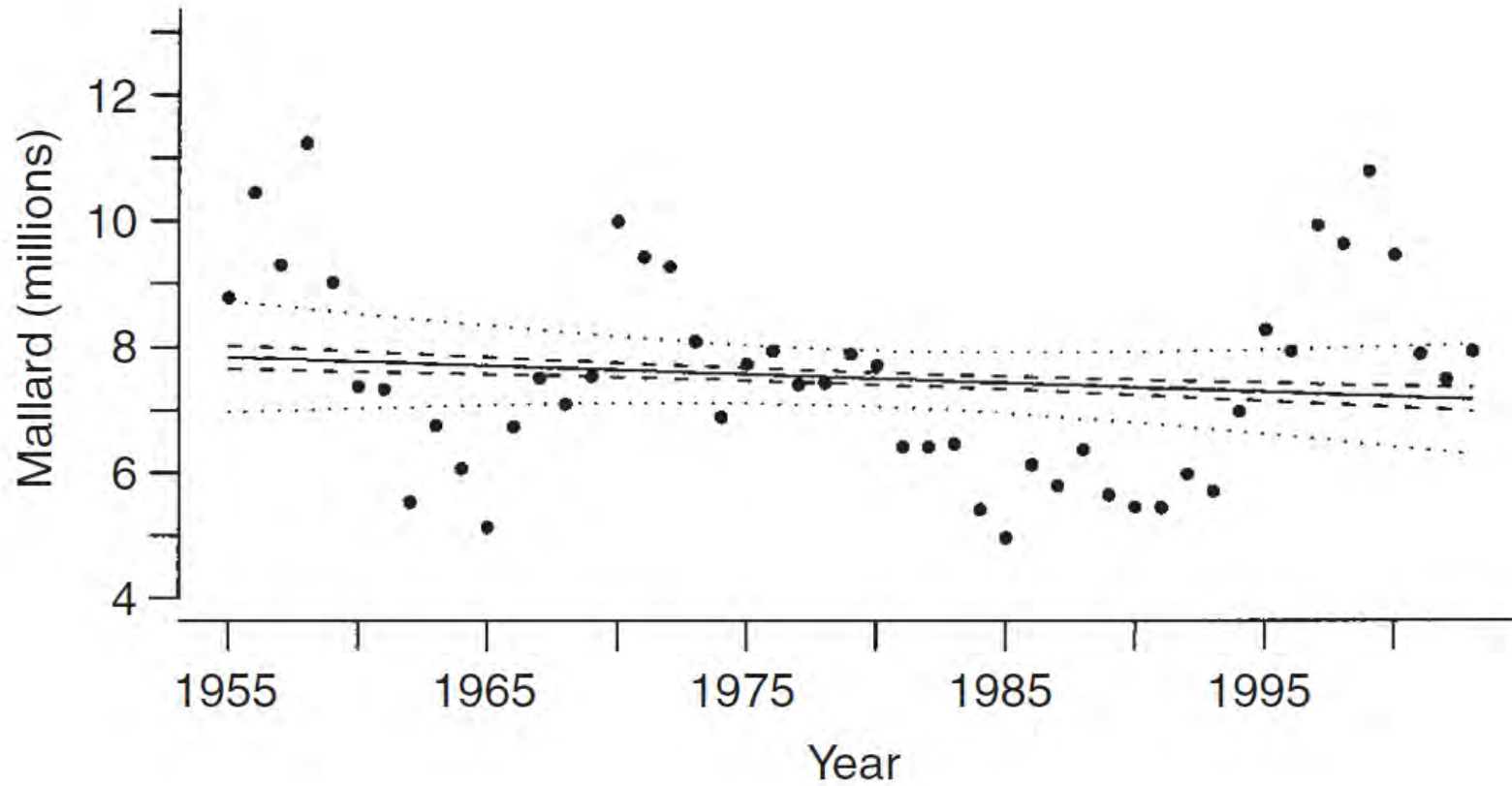

That is long-term?

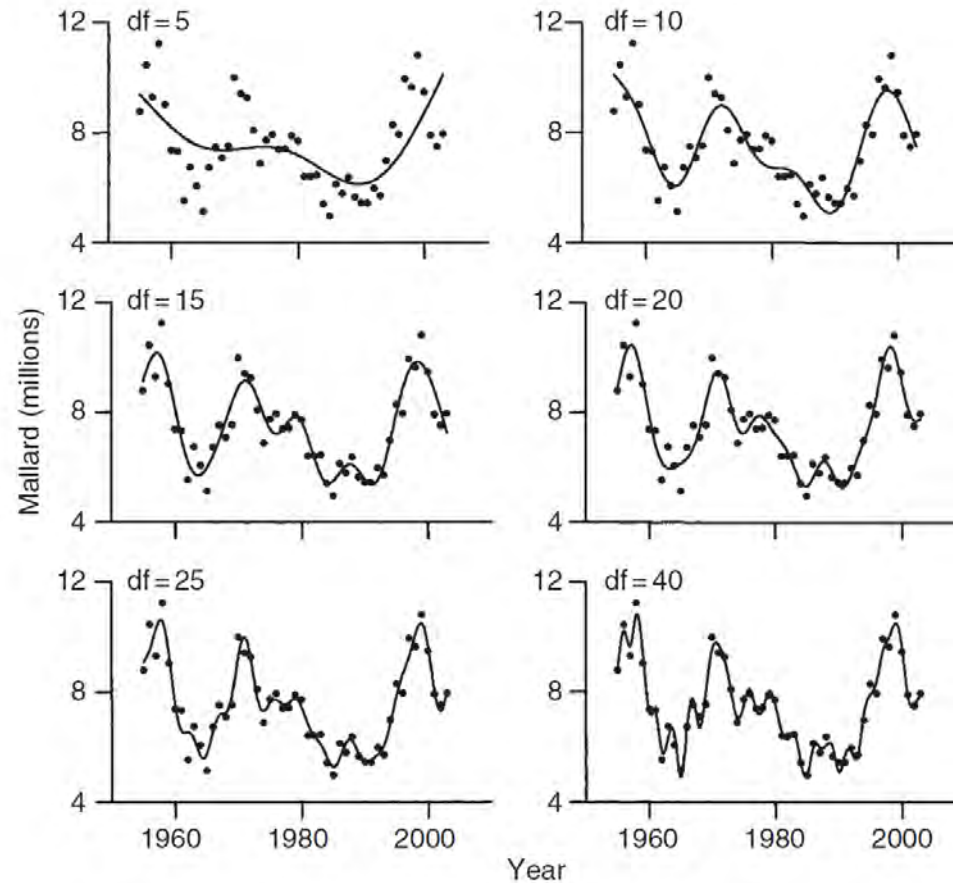

Empirical trend analysis can be subjective!

Observation vs process error

- Observation error (aka sampling variation) \approx expected difference between our estimate of some parameter and its true value
- Process error \approx expected difference between the true value of some parameter and its average value across all realizations of the population process

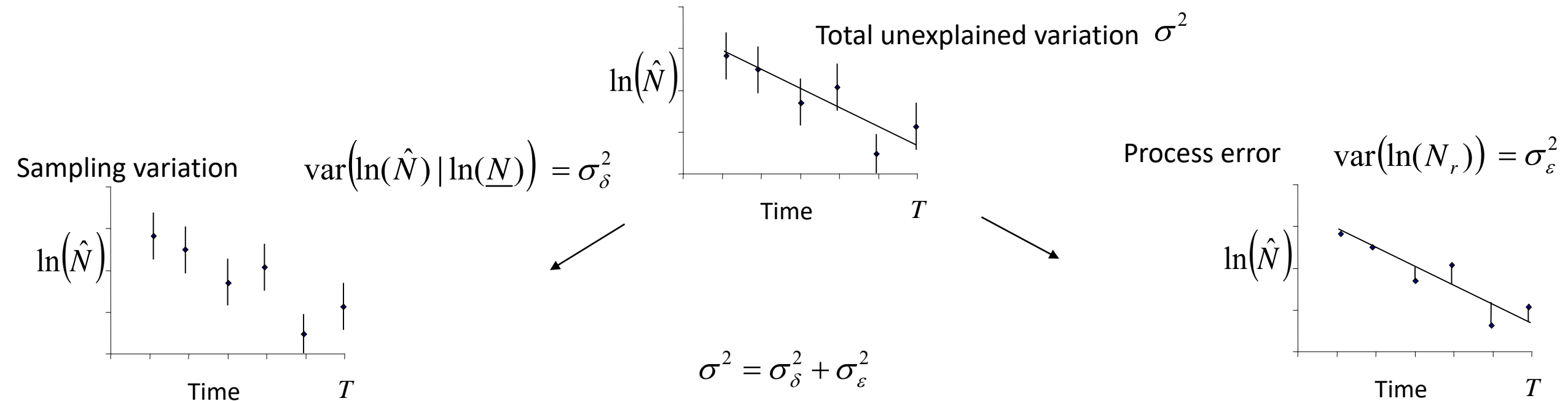

Temporal change: other considerations

- Temporal change
 - Empirical vs process-based (mechanistic) model
 - Can combine short- and long-term change models – look for sudden change coinciding with intervention, in addition to trend
 - Nevertheless, change could be caused by some other factor

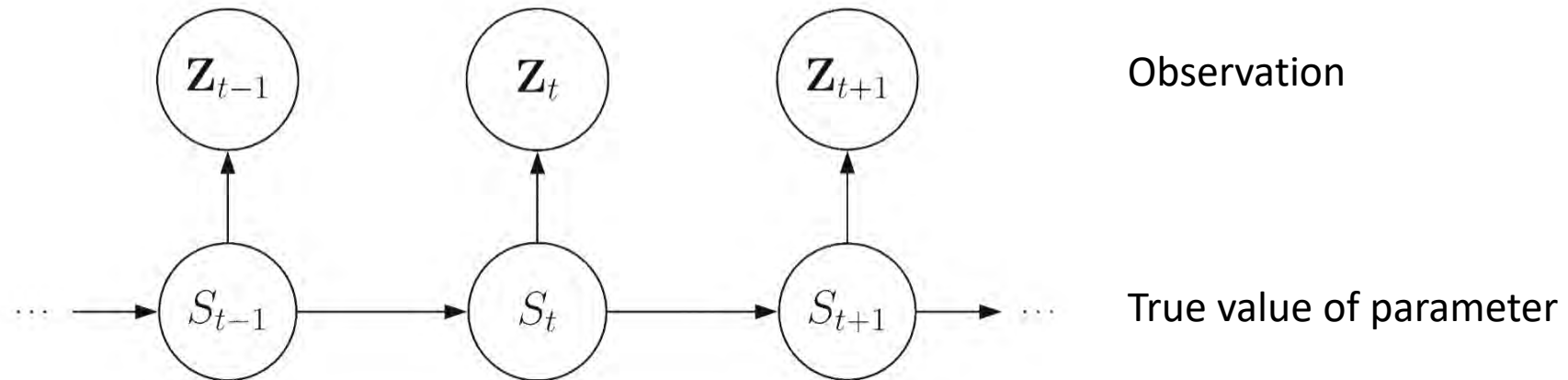

E.g., Thomas et al. (2004) Advanced Distance Sampling; Newman et al. (2014) Modelling population dynamics

Spatial change

- Spatial change (i.e., differences between locations)
 - Difference between sites
 - More refined spatial analysis, possibly with covariates
 - Doesn't say if there's actually been a change – could be the two areas were different beforehand.

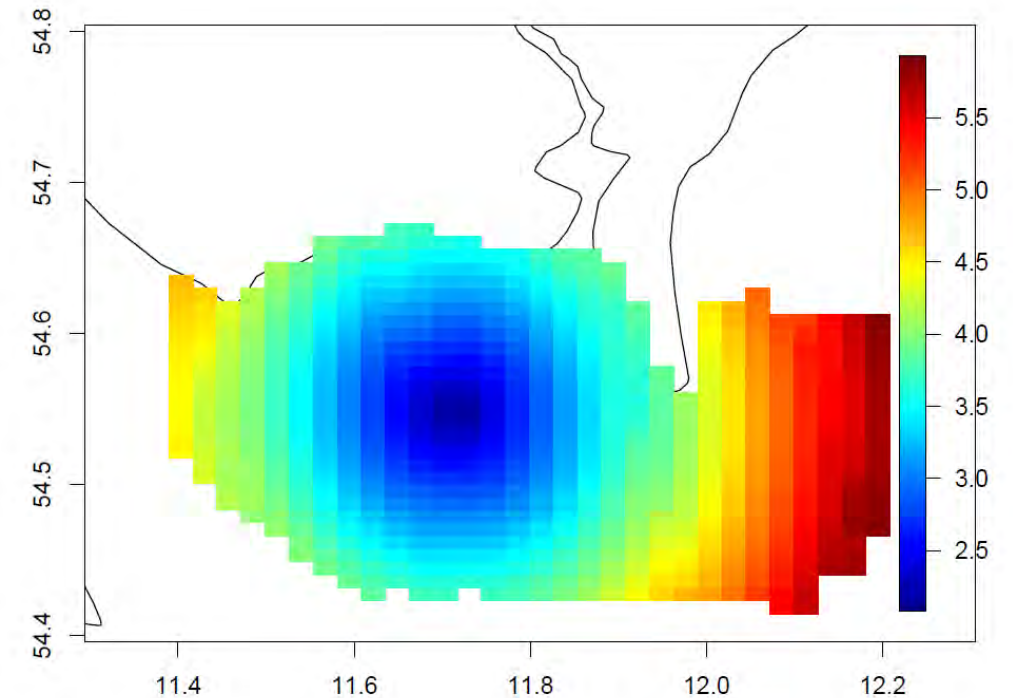

Oedekoven et al. (2013) Literature review

Spatio-temporal change

- Spatio-temporal change.
 - Before After Control Impact (BACI)
 - Spatio-temporal models – effect is in the interaction term of the model

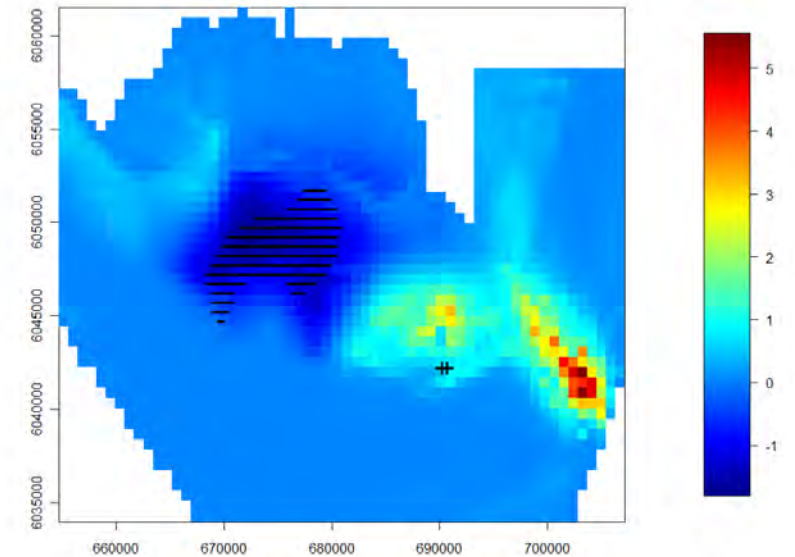

Figure 17: An example plot showing statistically significant pre-post declines (-) and increases (+) based on GEE-based confidence intervals for pre-post differences.

Oedekoven et al. (2013) Literature review

Parameters of interest

Population (stock abundance)

- MMPA definition of stock? Relevant temporal scale (year?)
- (Note density is not necessarily the same thing as abundance as density can increase as range contracts.)
- Data: counts (sightings, recaptures, calls, etc), with scaling factors (multipliers)
 - detectability; cue rate; group size
- Analysis:
 - can be complex to get abundance
 - can do “change” analysis separately, or integrate with abundance estimation (little advantage, usually)
- Pro: definitive – abundance is the “bottom line”
- Cons: expensive, difficult in some cases, expensive; slow to react; only a small proportion of population may be affected; doesn't tell you “why”

Relative population abundance - indices

- Counts without (all) scaling factors
- Analysis similar to abundance
- Pros: easier, cheaper
- Cons: confounding – e.g., underwater sound may decrease abundance but increase visibility!

Different indices calculated on the same survey data

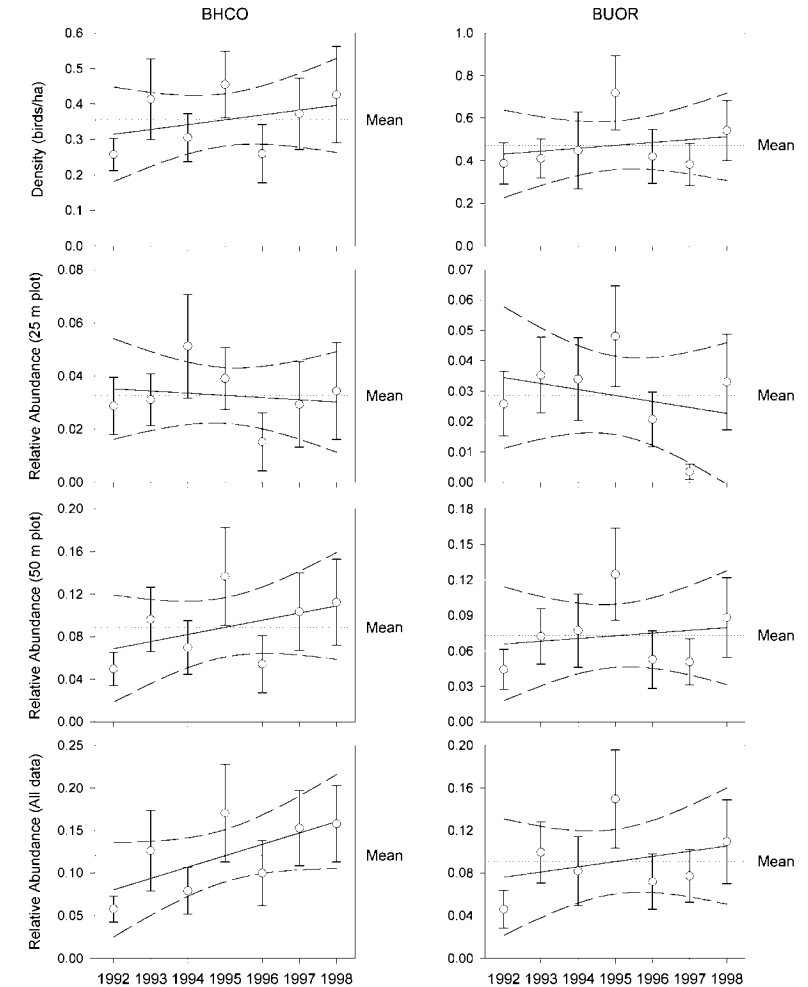

Occupancy

- Needs repeated sampling at a set of defined sites
- Occupancy = $\text{prob}(\text{abundance} > 0)$ at a site
(not to be confused with detection/non-detection, which is an index)
- Uses modelling to deal with detectability
- Pros: cheaper than abundance
- Cons: much less sensitive, especially at core sites that have relatively high density

Local spatial density / abundance

- Estimate density/abundance change in the vicinity of the impact (as opposed to the whole population), and possibly at control sites
- Various temporal scales
- Pro: more focussed than stock-level analysis
- Cons: does not demonstrate stock-level effect

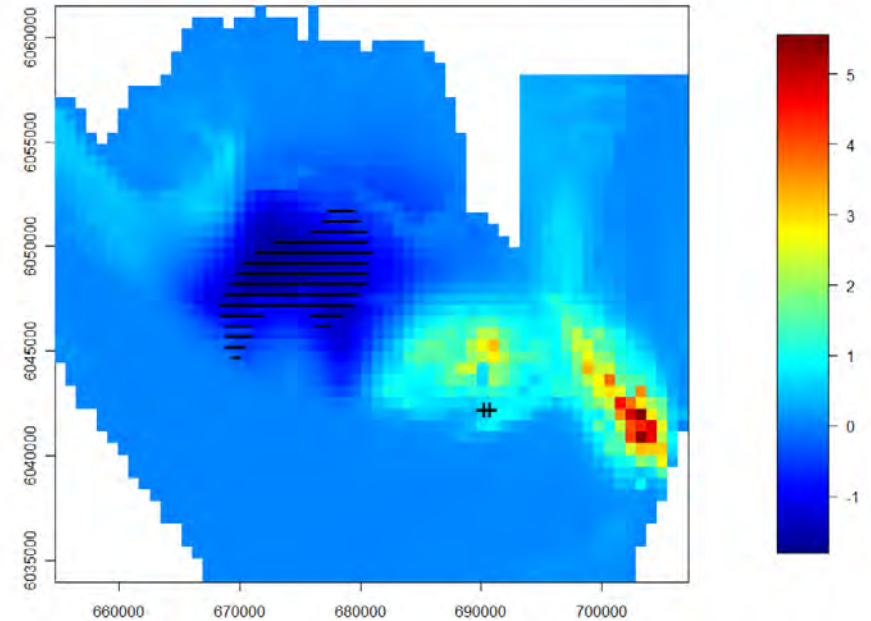

Oedekoven et al. (2013) Literature review

Local spatial indices of abundance

- Similar to previous but based on indices
- Pros and cons as previous abundance/indices comparison

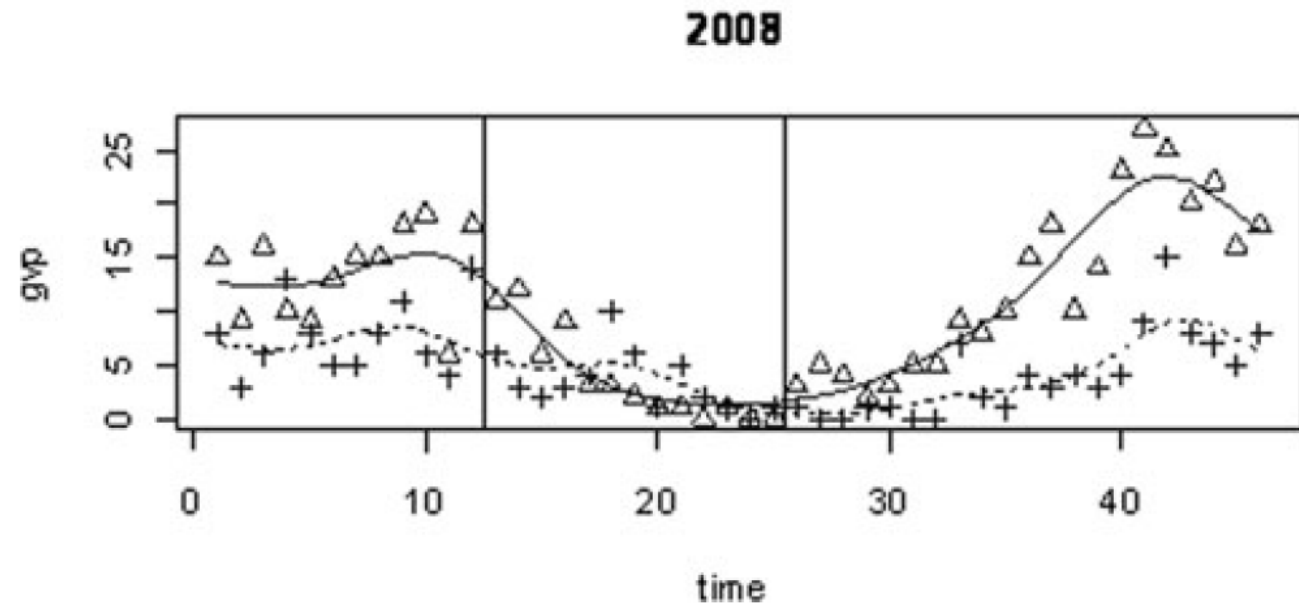

McCarthy et al. (2011) Marine Mammal Science

Movement

- Avoidance behaviour of individuals
- Data: tracks from tags, (acoustics,) or mark-recapture
- Inferences about population-level effects (e.g., change in density) rely on assumption you have marked “random” animals in population
- Pro: individual-level inference
- Cons: Can be expensive; does not give population-level effect on abundance

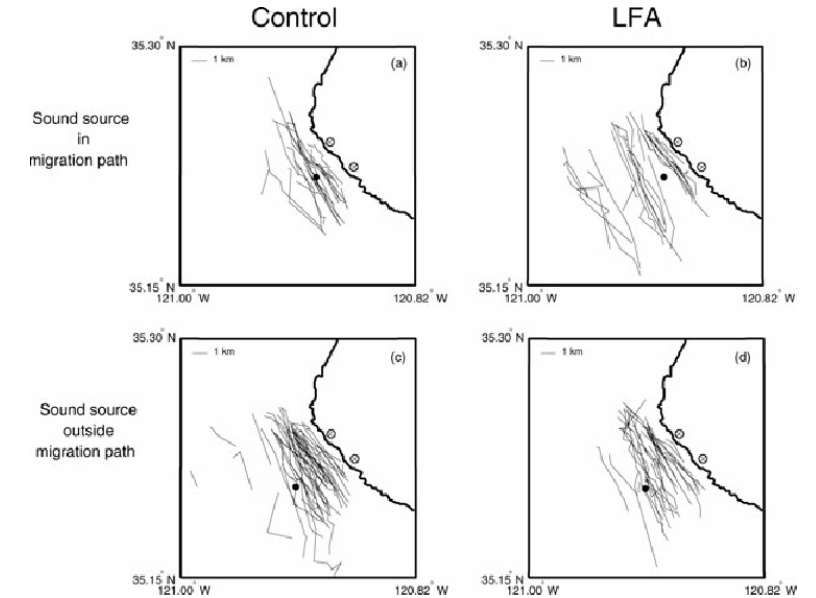

Buck (2000) JASA

Demographic parameters

- Birth, survival, immigration, emigration
- Data: mark-recapture or other individual-level data
- Pros: Gives an explanation for inferred changes in abundance; feeds mechanistic models
- Cons: Can be hard to measure (depending on population)



FinBase - Catalog Browser

FinBase
Catalog Browser

ID: 1000
Alias: MUTT
FB: 041
Age: 32
YOB: 1991
Sex: Female
Alive: No
Home:

CatalogID: Alias
1000

CatalogID	Alias	Frequency
1038		3
2027		2
2028		2
7105		2
2105		1
2165		1
3005		1
6005		1

Image	Date	Survey	Sighting	CatalogStatus
4_3PG	4/21/2004	466	7	No
5_3PG	5/11/2004	472	13	No
1_3PG	2/20/2004	426	3	No

Survey	Sighting	Date	Survey Type	Survey Area	Confirmation	DuplicateClass	DuplicateReason	Construction
472	13	5/11/2004	Photo-d	SPE	Verified	Other	High	None
466	7	4/21/2004	Photo-d	DHS	Verified	Other	High	None
426	3	2/20/2004	Photo-d	DHS	Verified	Other	High	None

Indices of demography

- E.g., mother-calf or adult-juvenile ratio
- Pros: Much easier to measure in some populations; could be a sensitive indicator of population-level effects
- Cons: Hard to interpret in some cases – many possible alternative explanations



NOAA image

Body condition / health

- Data: health assessments, photogrammetry, visual assessment, biopsy
- Pros: Could be a sensitive index of impending issues
- Cons: Hard to interpret; can be relatively hard to measure

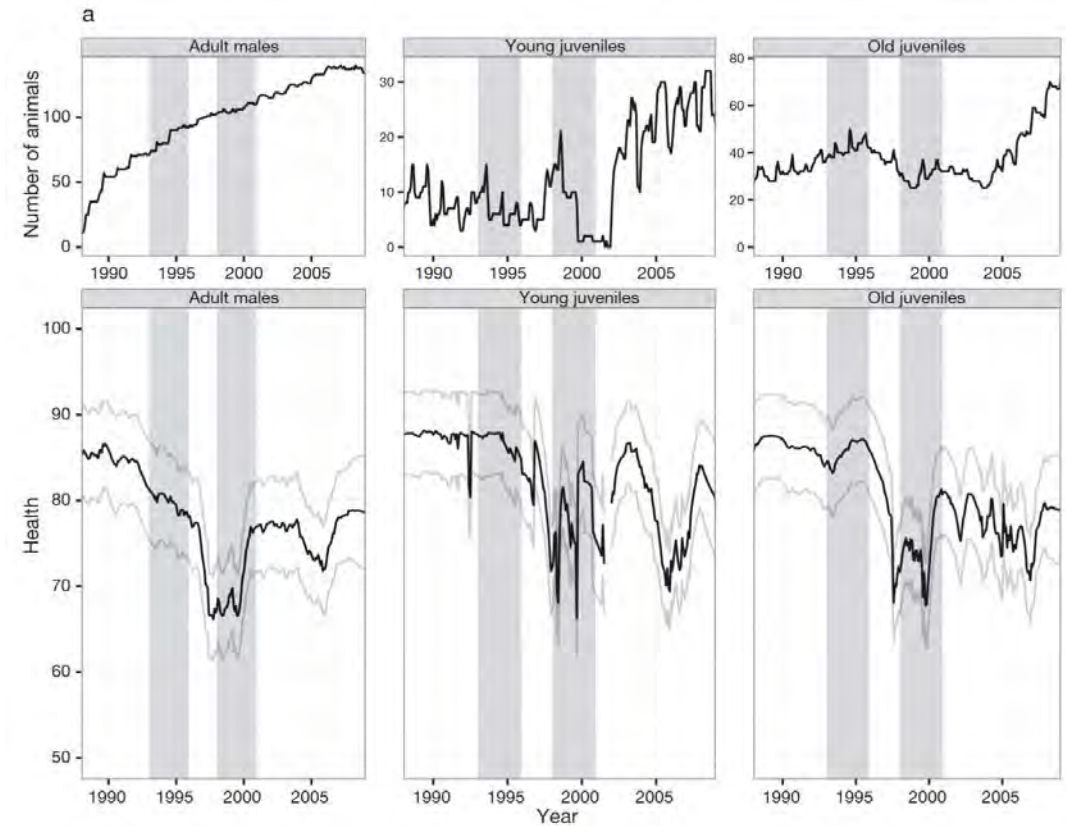

Rolland et al. (2016) MEPS

Physiological / behavioral measures

- Data: Short-term avoidance response, stress hormones, etc.
- Pros: Can be a sensitive measure of possible individual-level effects
- Cons: a long way from population-level effect!

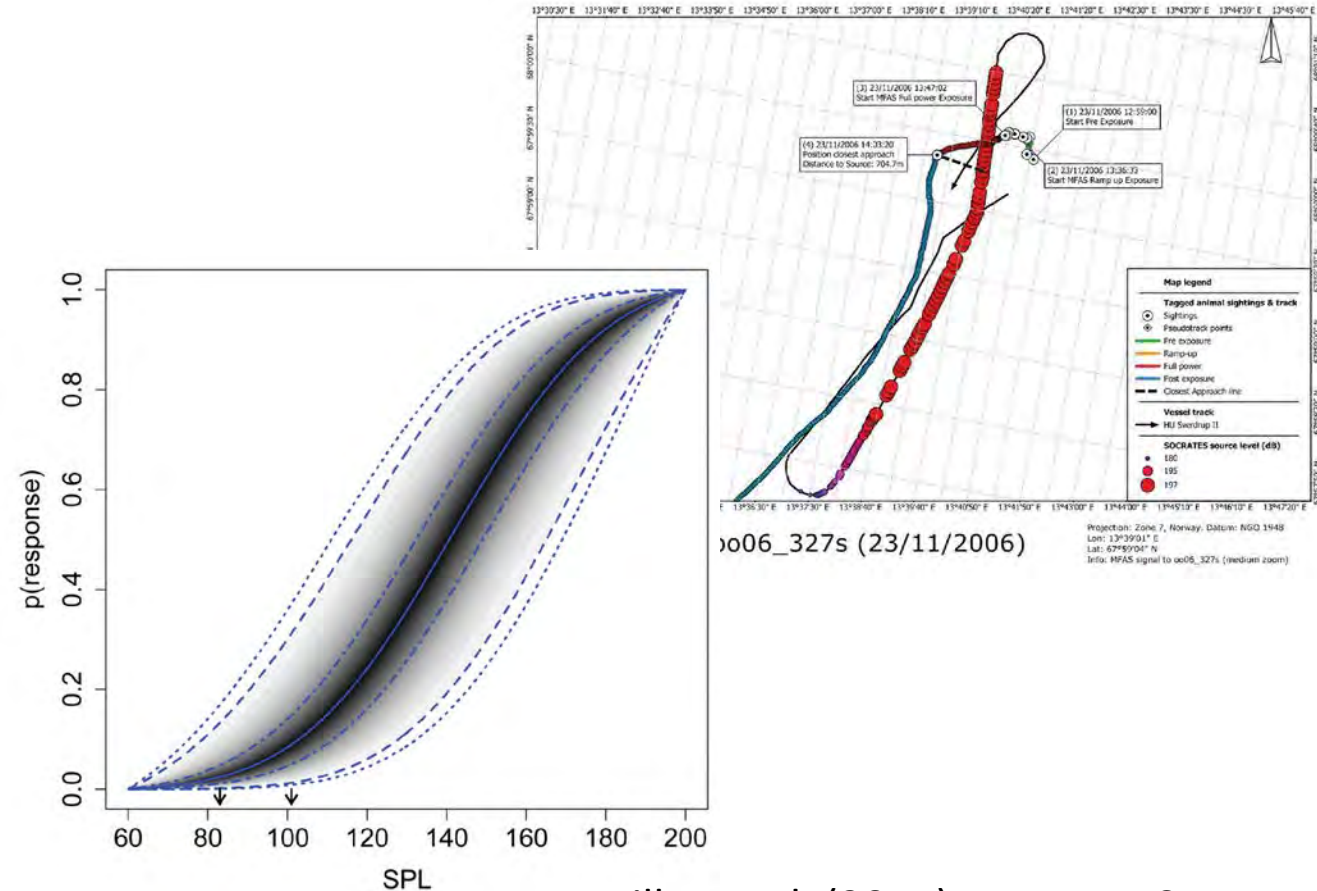

Miller et al. (2014) J. Acoust. Soc. Am.

Putting it all together

Population Consequence of Disturbance

- Origins:
- 2005 report from the National Academies' Committee on Characterizing Biologically Significant Marine Mammal Behavior

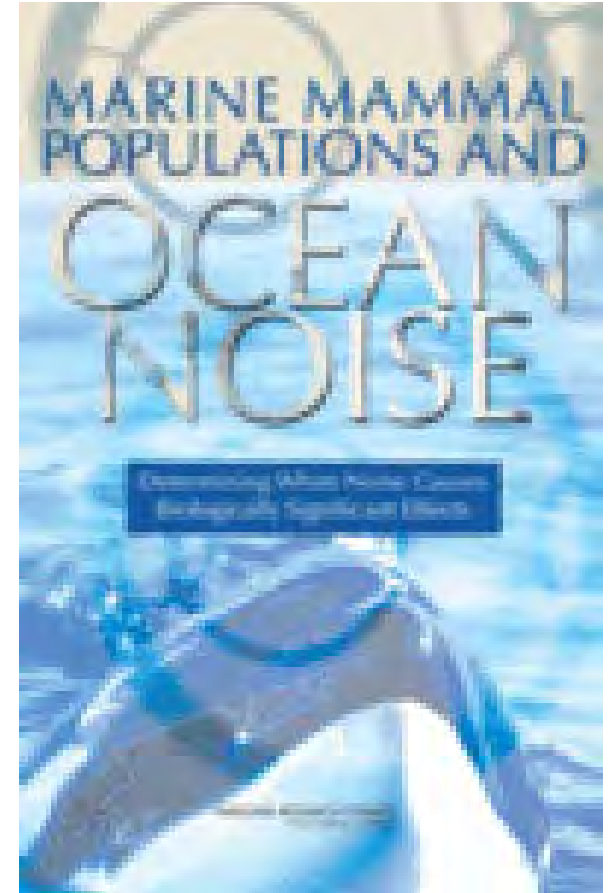

NRC 2005 report

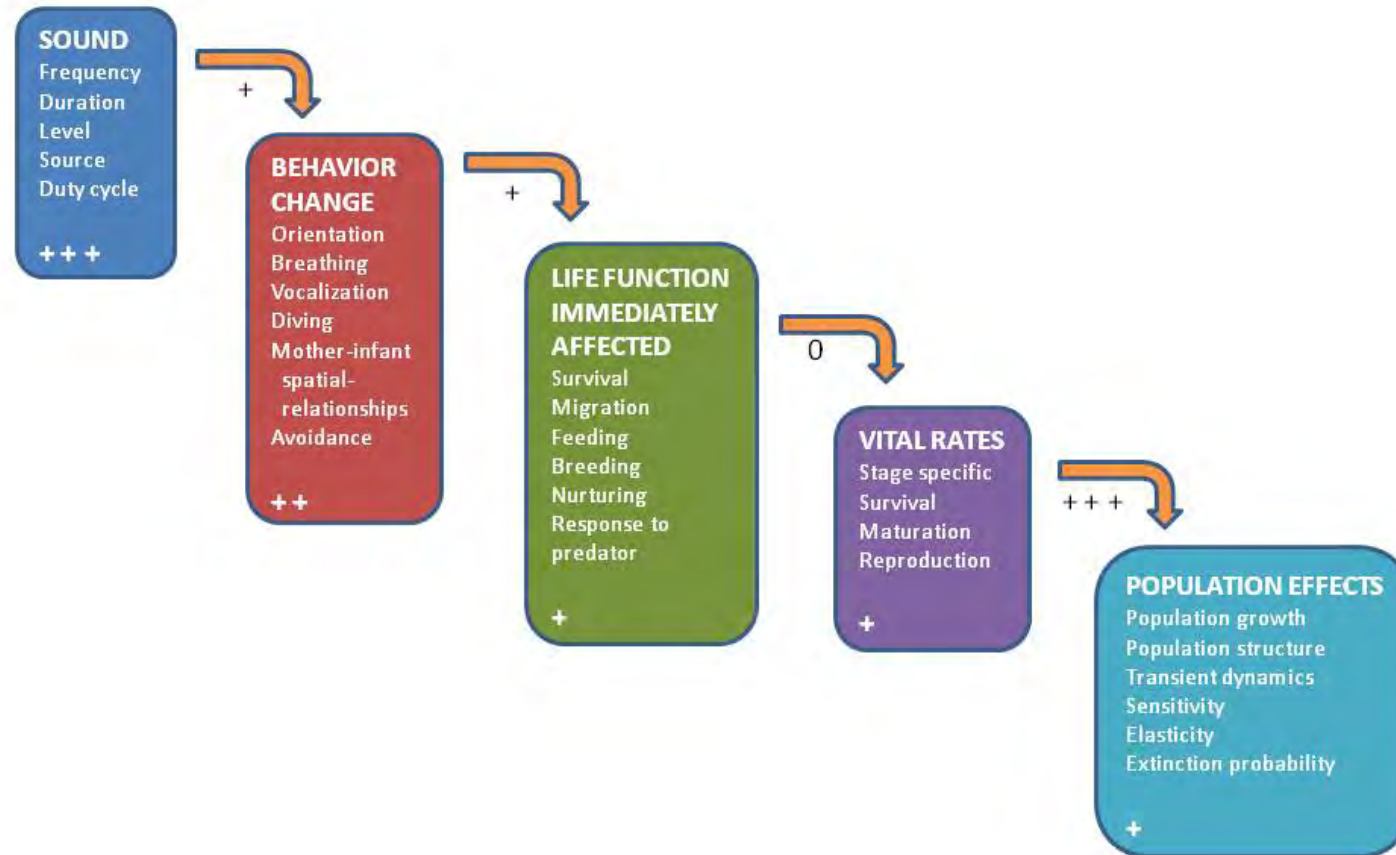

ONR PCoD working group

Individual-level

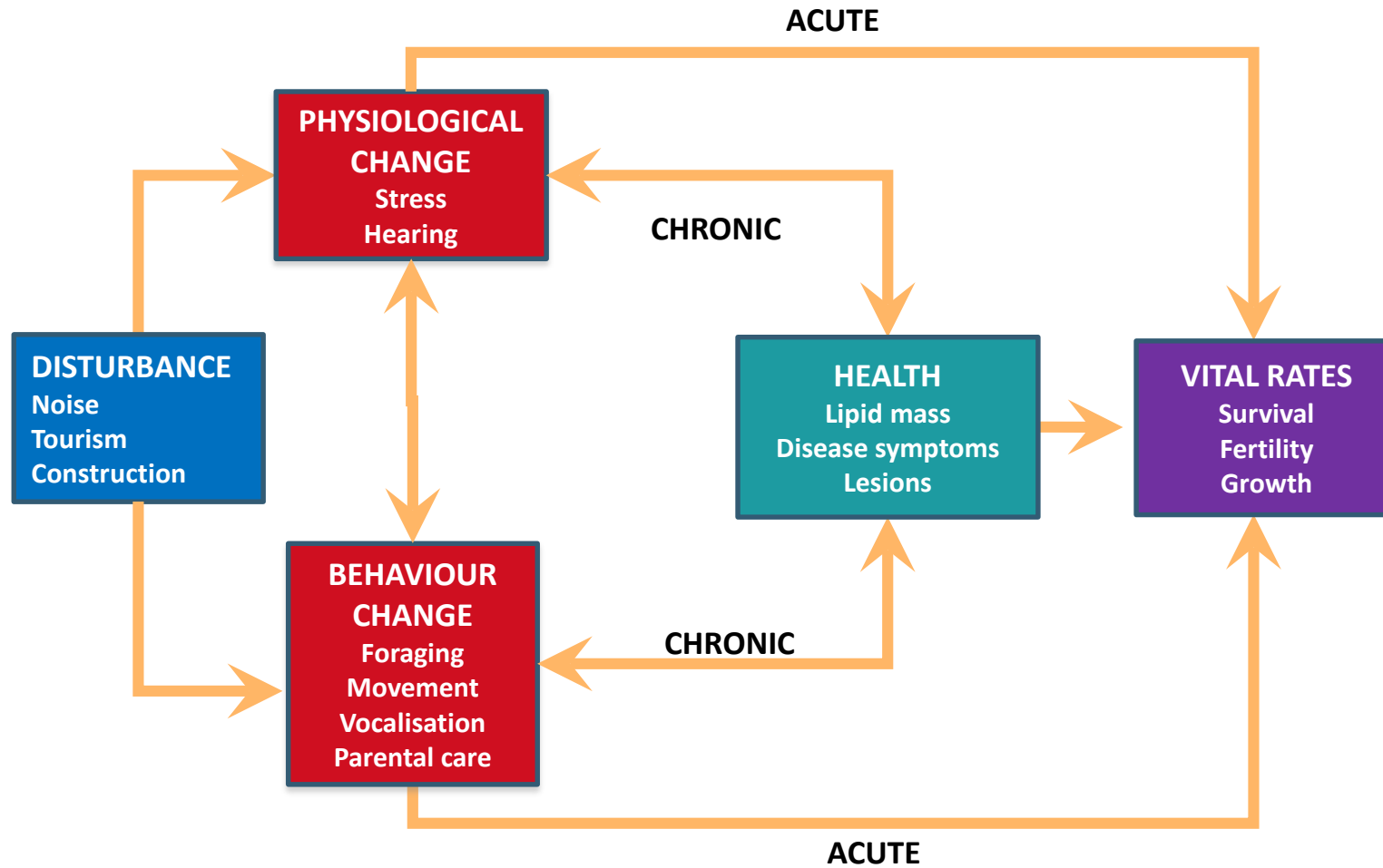

ONR PCoD working group

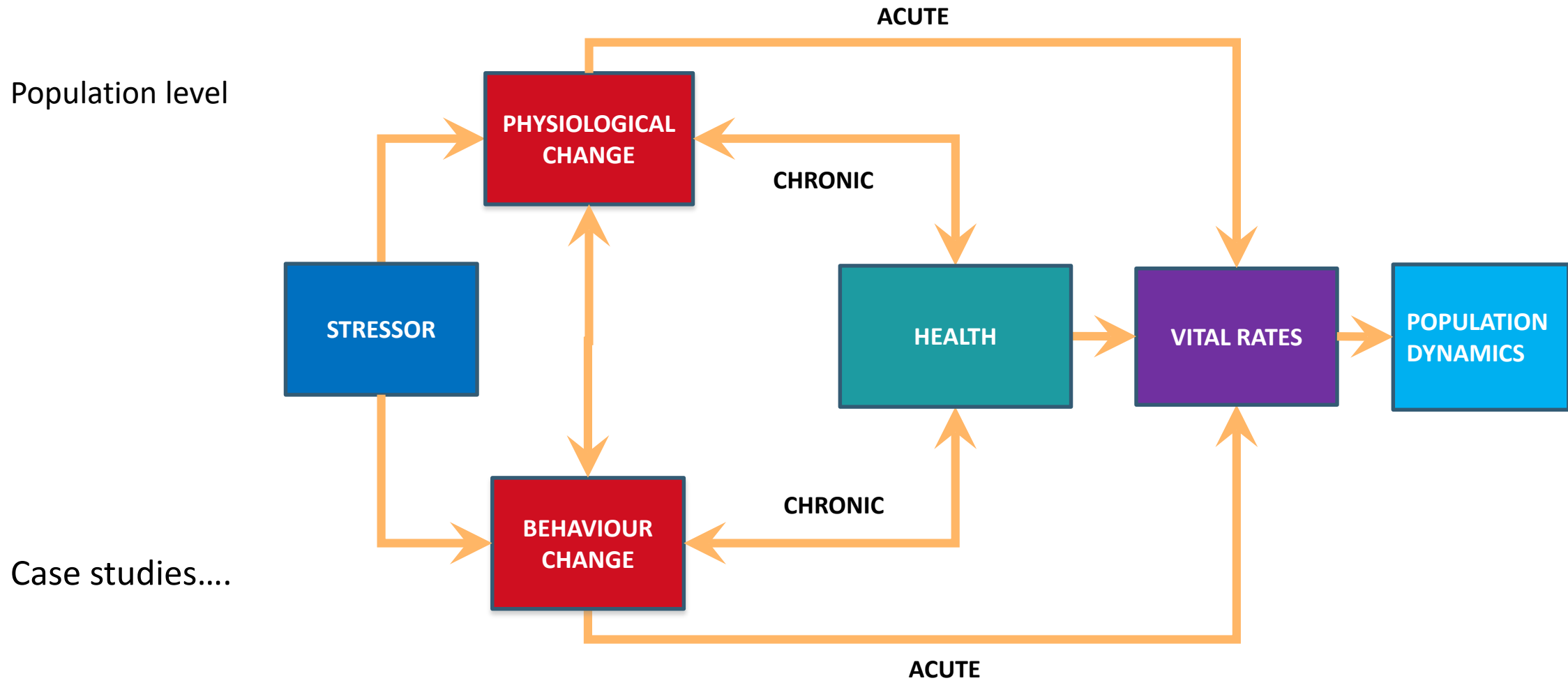

NRC 2016 Cumulative effects

- Cumulative effects – Population Consequences of Multiple Stressors (PCoMS) model

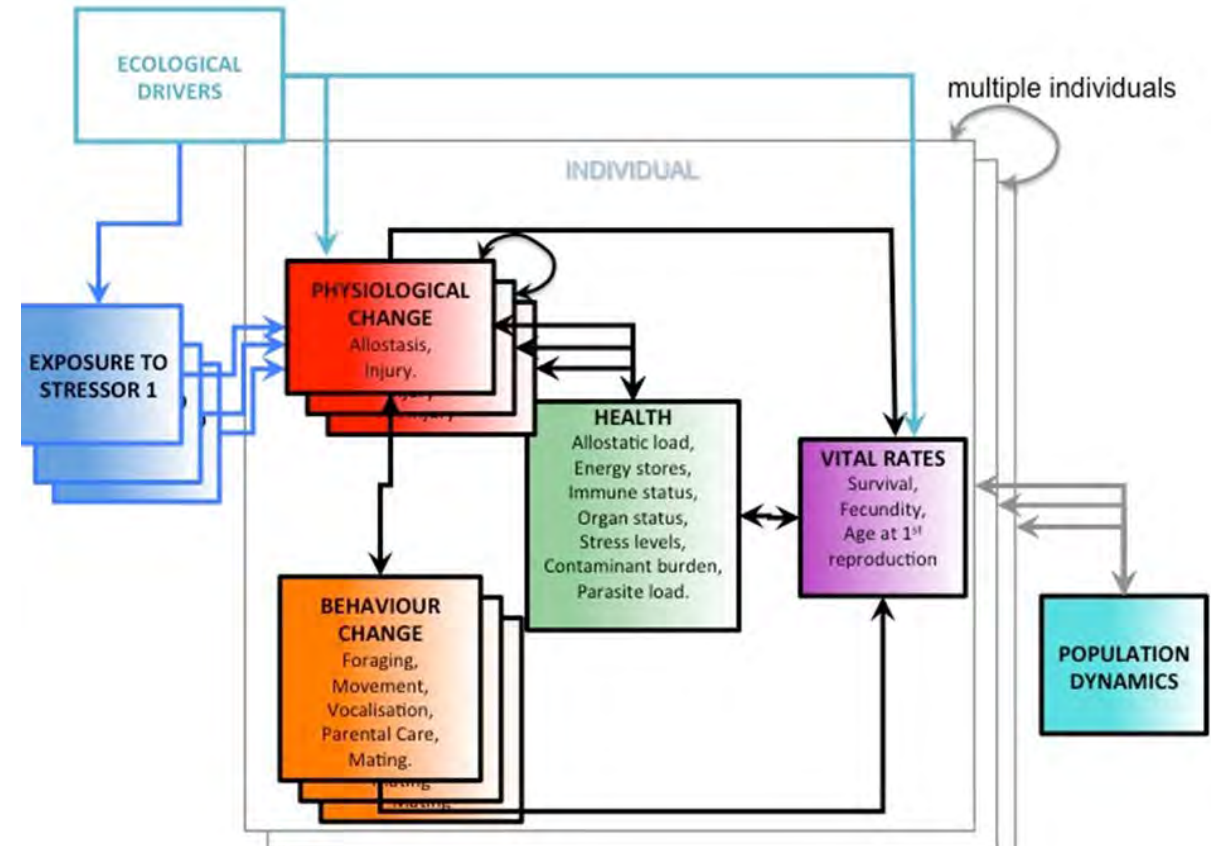

National Academies. 2017. Approaches to Understanding the Cumulative Effects of Stressors on Marine Mammals

Other considerations

Inferring causation

- Experimental (manipulative) study
 - Randomization
 - Replication
 - Control
- Observational study
 - Classically, cannot infer causation, only correlation
- Quasi-experimental study



Adaptive management – learning by doing

- E.g., Williams (2011) J. Env. Management (2 papers)
- View management actions as experiments
- Multiple working hypotheses – update as more information is gathered – affects optimal management
- Passive adaptive management vs active adaptive management
- In our situation, perhaps learning is too slow for adaptive management to be useful?
- Adaptive monitoring (hypothesis-driven monitoring) – Nichols and Williams (2006) TREE; Lindenmayer and Likens (2009) TREE

Features of successful long-term monitoring programs

From Thomas et al. (2004); contributed by Ken Burnham.

- Concrete goals; good statistical design; pilot survey
- Technical advisory board; regular review; adaptability (new techniques, new biological knowledge, unforeseen changes)
- Good documentation and quality control; regular peer-reviewed publications
- Long-term funding; well-paid long-term staff; good training program

These features are difficult to obtain and maintain due to short-term nature of most institutional funding.



Anderson Cabot
Center for Ocean Life
at the New England Aquarium



Survey Methods

Dr. Scott Kraus
Anderson Cabot Center for Ocean Life
At the New England Aquarium

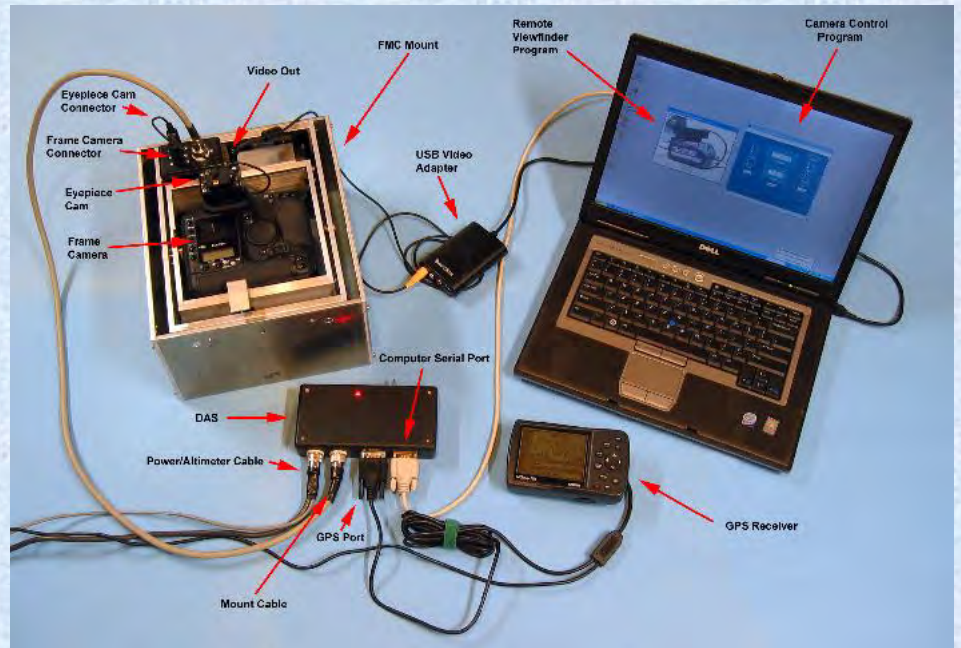
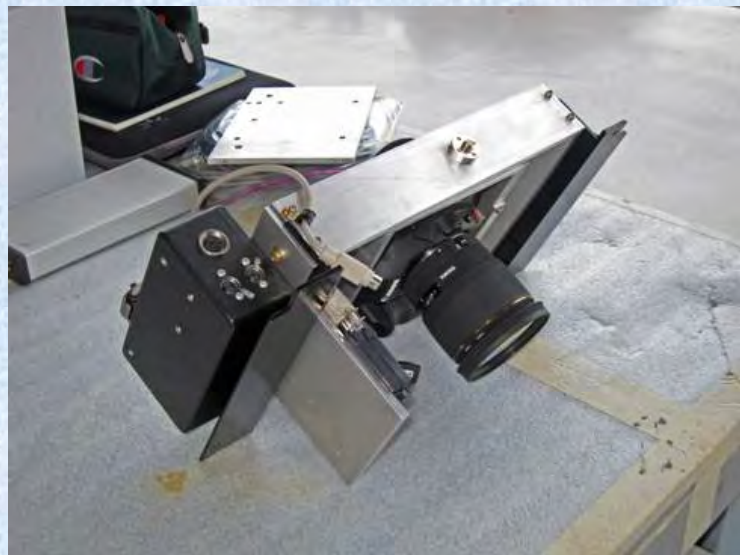

Cessna Skymaster O-2 Observer and Camera Viewfields

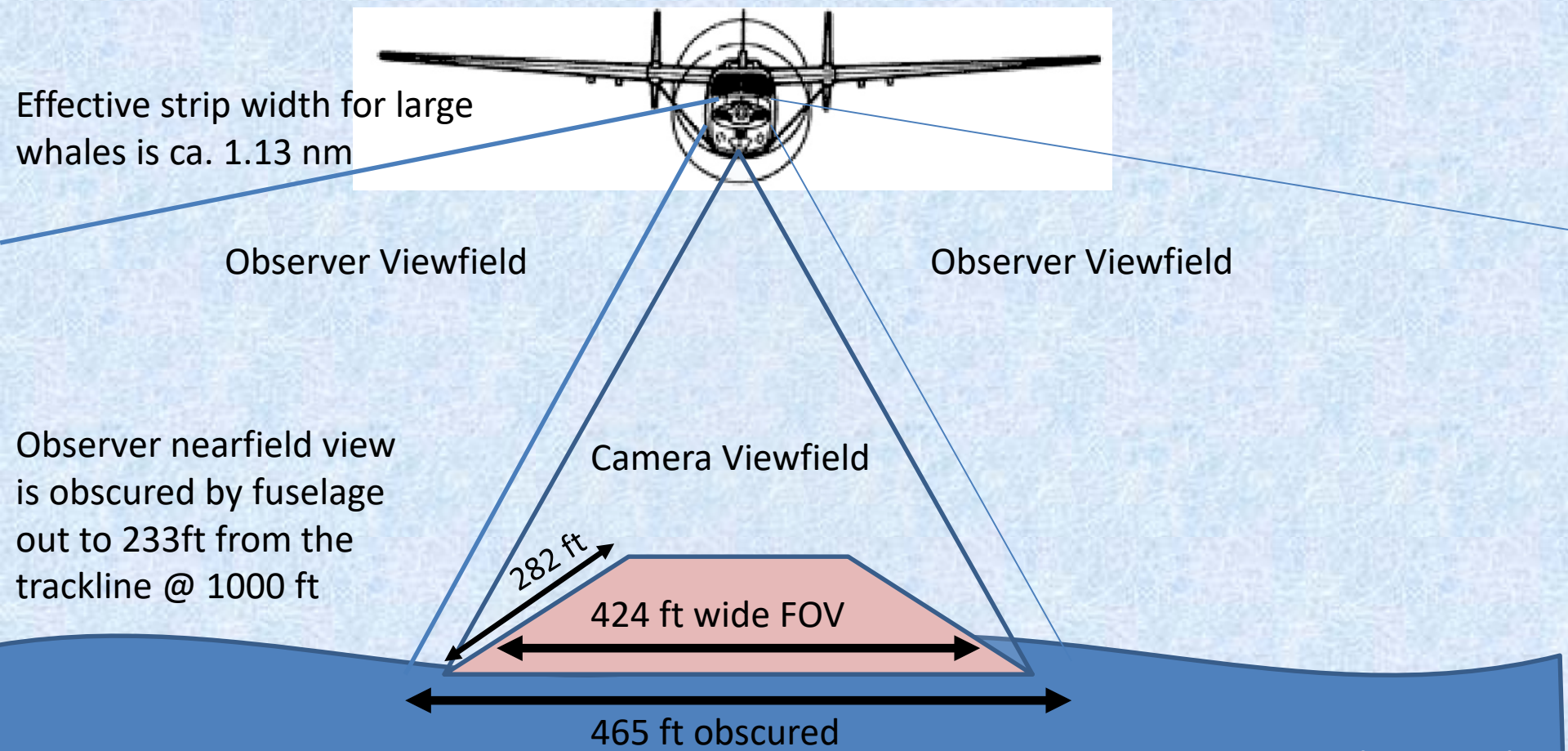

Effective strip width for large whales is ca. 1.13 nm

Observer Viewfield

Observer Viewfield

Observer nearfield view is obscured by fuselage out to 233ft from the trackline @ 1000 ft

Camera Viewfield

282 ft

424 ft wide FOV

465 ft obscured

Probability of detection of animals or groups declines with their distance from the transect. In line-transect (or distance) sampling theory, $f(0)$ is the probability density function of right-angle sighting distances (for that species and platform) evaluated at a distance of 0. The reciprocal of $f(0)$ is the "effective strip width," a statistical estimate of the area effectively searched on either side of the transect.

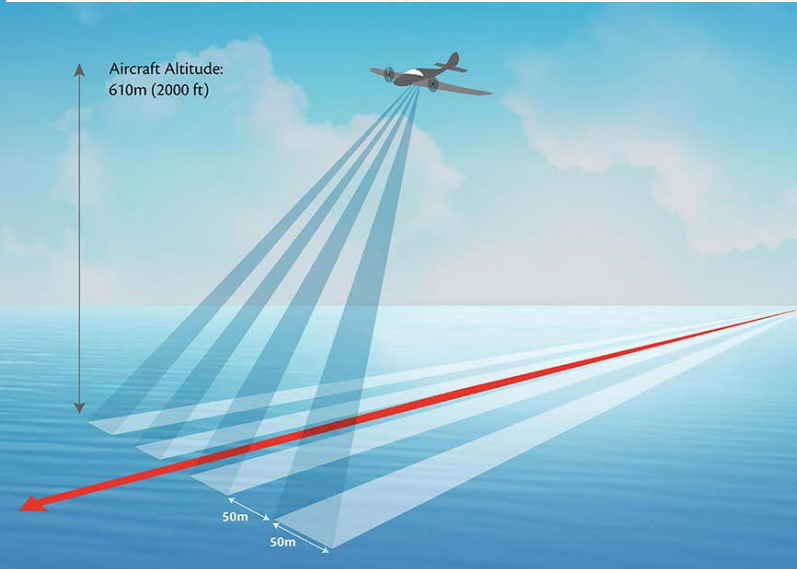
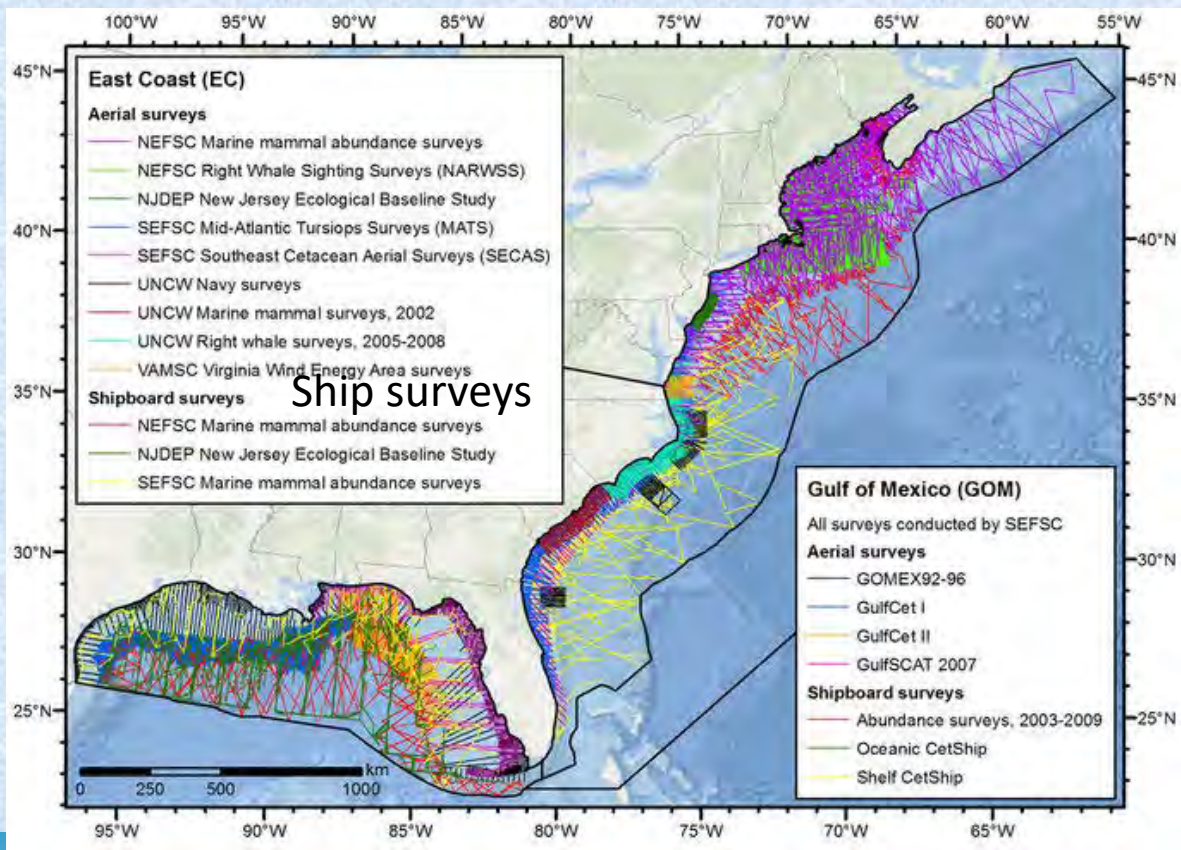

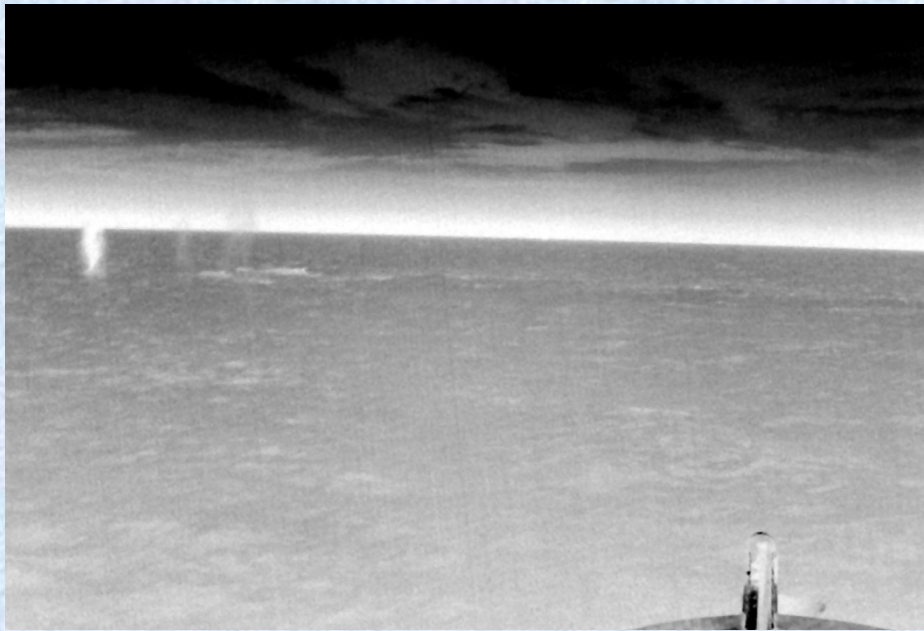

Sensors
IR
Radar
Lidar

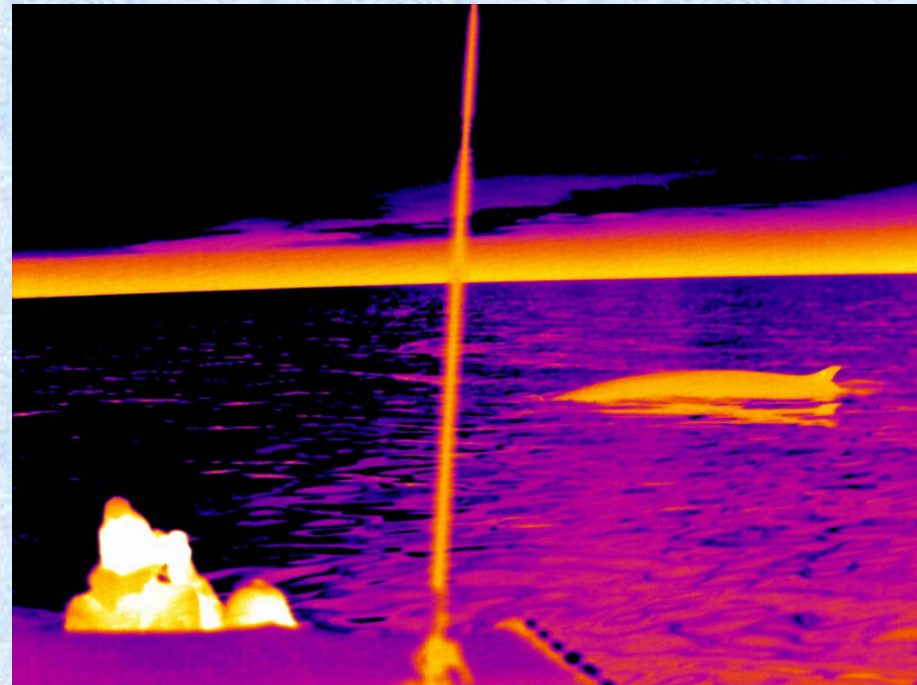
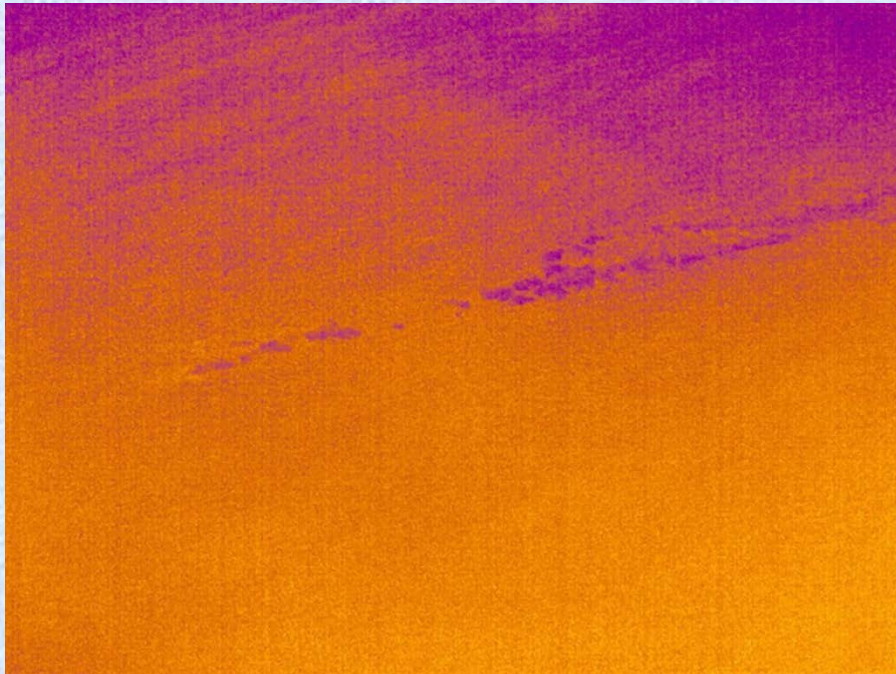

Passive acoustic monitoring



- Listen for sounds marine mammals make
- Detection is dependent on animals making sounds
- **Archival**
 - Least expensive option
 - Access to detections is delayed until recorder is recovered and data analyzed
- **Real time**
 - More expensive than archival recording, but likely more cost effective than visual surveys
 - Access to detections in near real time (e.g., within hours of calls being made)

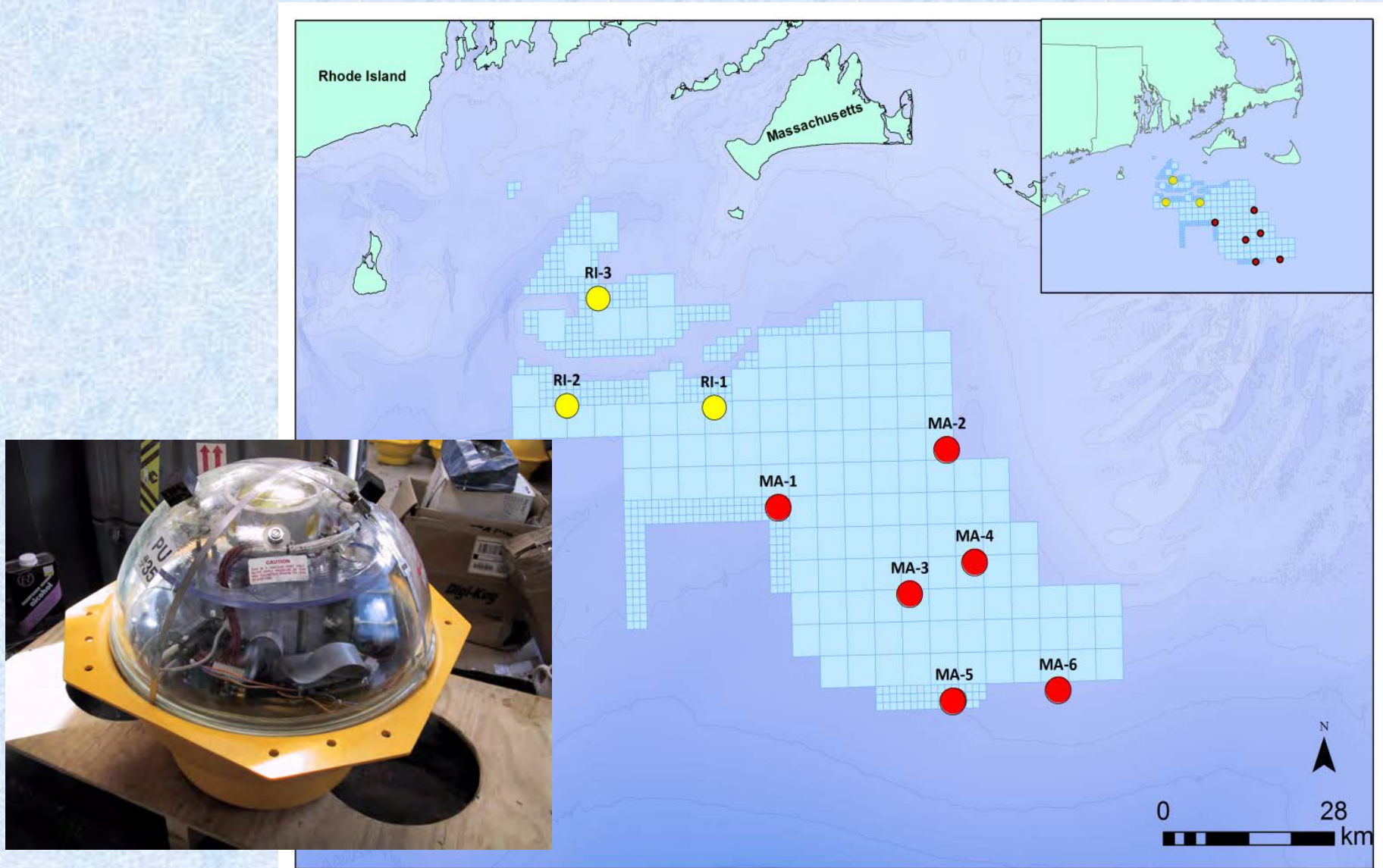

Map of the MA array of MARUs within the Mass Wind area (red circles) and the RIMA array of MARUs within the RIMA WEA (yellow circles). Light blue areas represent lease areas.

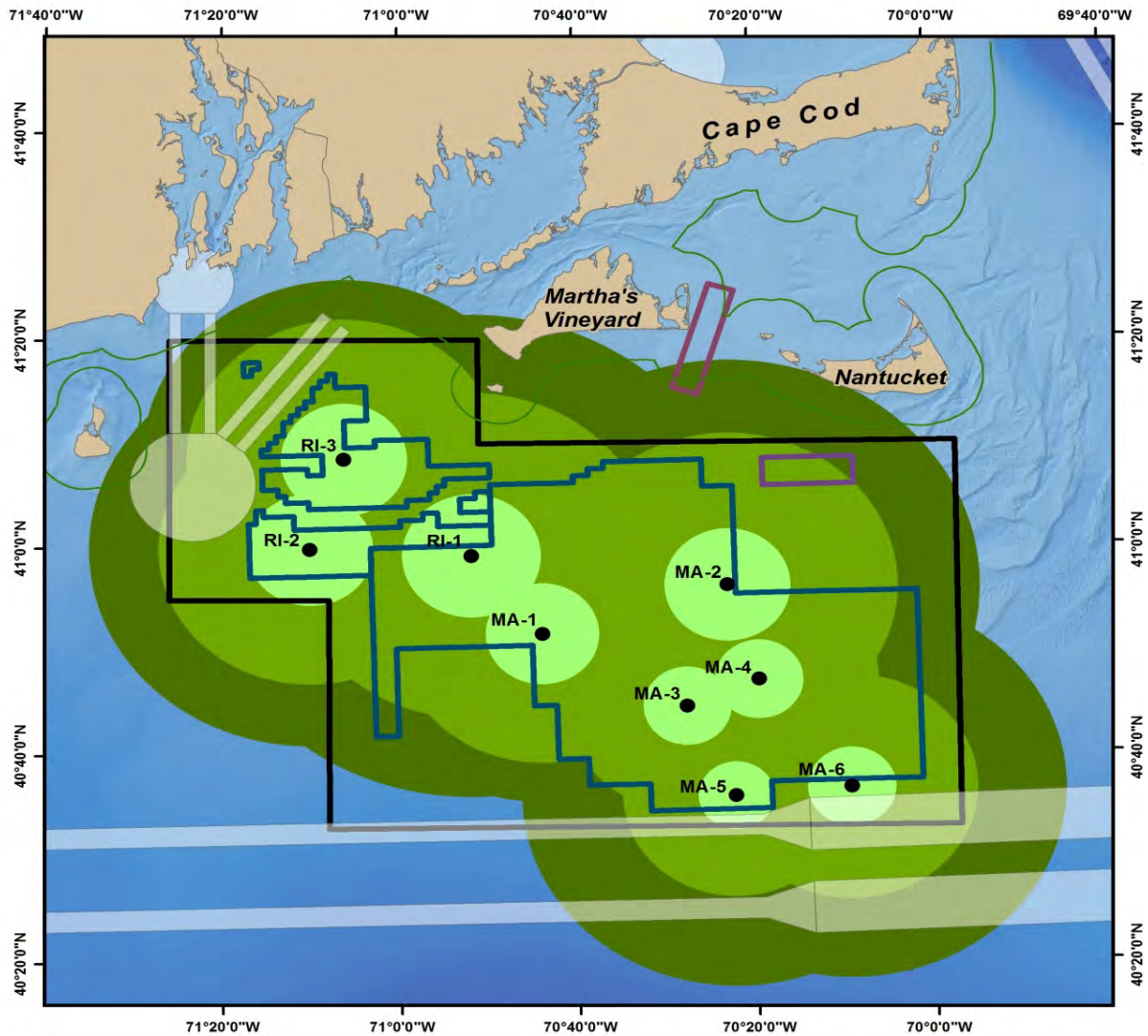

Acoustic Detection Ranges

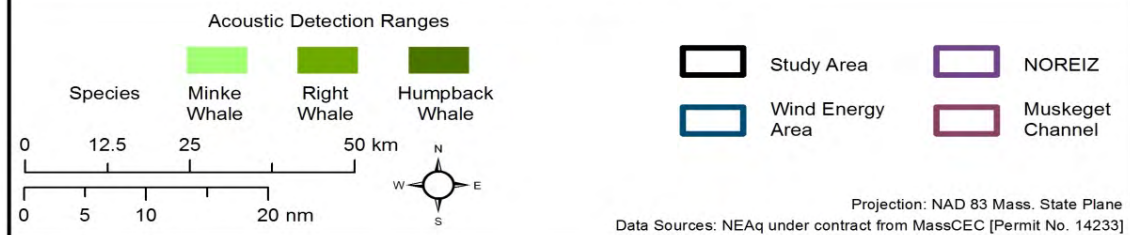

Archival passive acoustic monitoring



Bottom-moored recorders

- Stationary
- 6-12 month deployments
- Operational since 1990's

Slocum gliders

- Mobile
- Up to 4 month deployments
- Operational since 2005



Cornell pop-up buoys



Slocum ocean glider

Near real-time passive acoustic monitoring



Moored buoy, Slocum glider, and wave glider

- Long endurance (4-17 months)
- Allow quick access to acoustic detection information (e.g., within hours of calls being produced)
- Use satellite or cellular communications
- Operational since 2012 (Slocum glider), mid-2000's (Cornell Autobuoy), 2015 (WHOI DMON buoy)



Slocum ocean glider

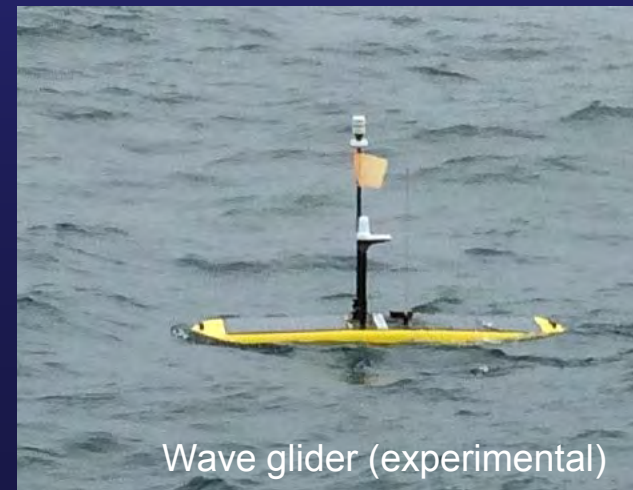

Wave glider (experimental)

Large-scale near real-time monitoring

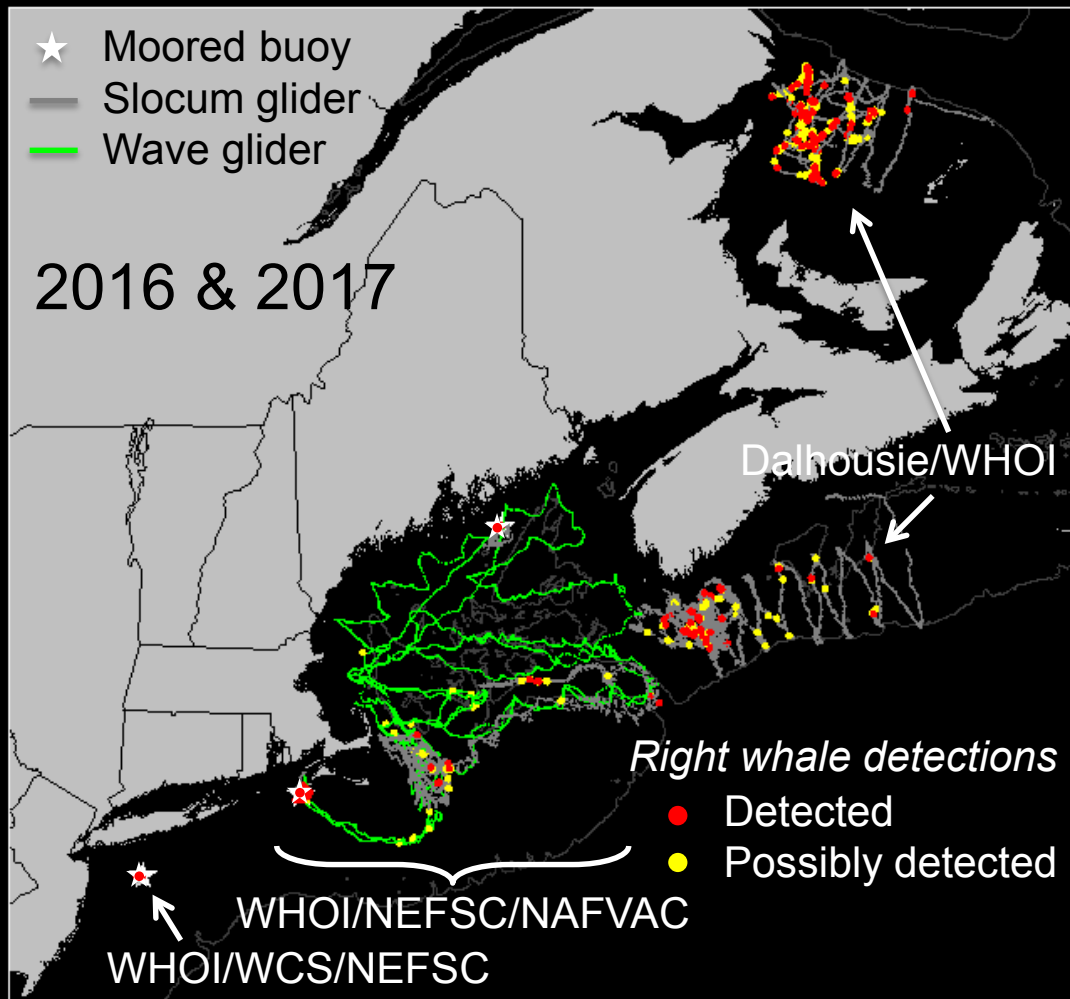

Moored buoy



1540 days
6 deployments
since 2015

Slocum glider

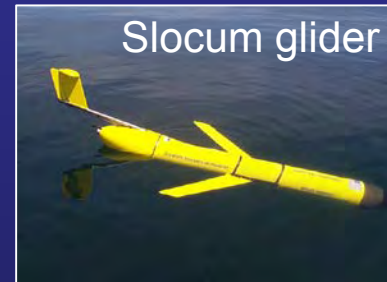

1242 days
30 deployments
since 2012

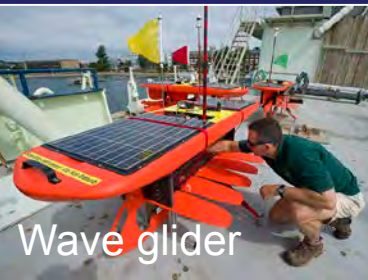

Wave glider

205 days
3 deployments
since 2015

Mark Baumgartner (WHOI), Sofie Van Parijs (NOAA NEFSC), Cara Hotchkin (NAVFAC), Chris Taggart, Kim Davies (Dalhousie University), and Howard Rosenbaum (WCS)



Copyright: Murdoch University Cetacean Research Unit (www.mucru.org)

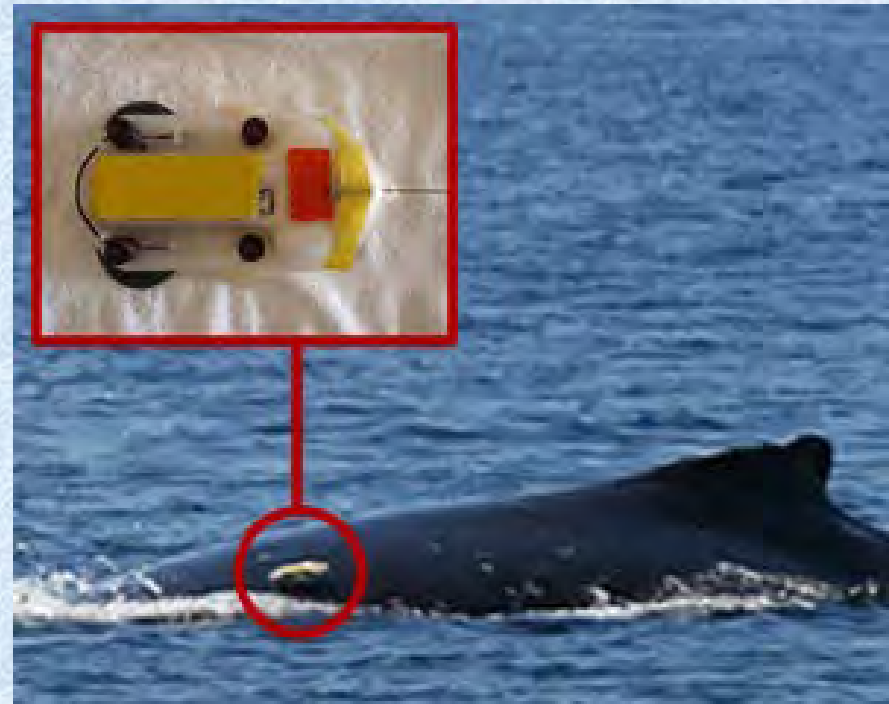

Drones for automated visual surveys

V-Bat

Griffin

AVWatch

Multiple sensor options

8-15 hours duration

Requires FAA or equivalent pilot/operators



HORMONES IN SCAT

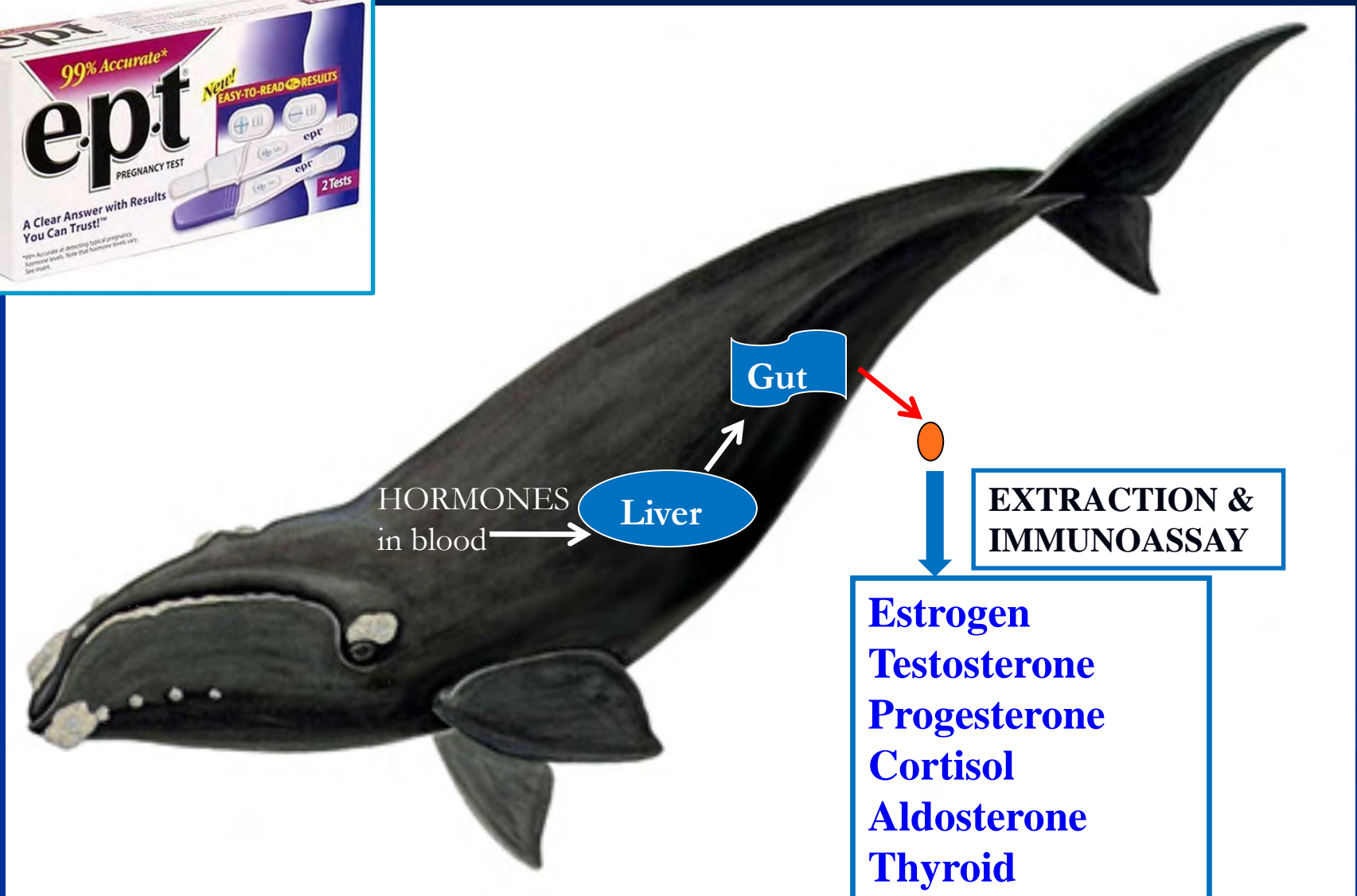

WHAT CAN HORMONES TELL US?

REPRODUCTIVE HORMONES

- Identify sex
- Sexual maturity(males)
- Females:
 - Pregnancy
 - Lactation



ADRENAL/THYROID

- Relative “stress”
- Metabolism
 - Temperature stress
 - Food limitation



Evidence that Ship Noise Causes Stress in Right Whales (2012)

THE 9/11 STUDY

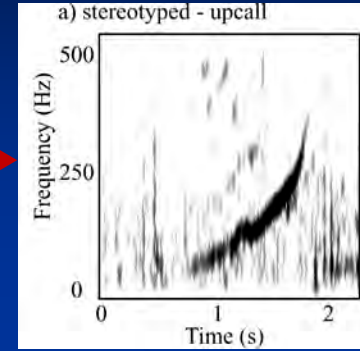
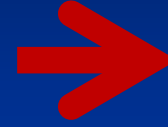
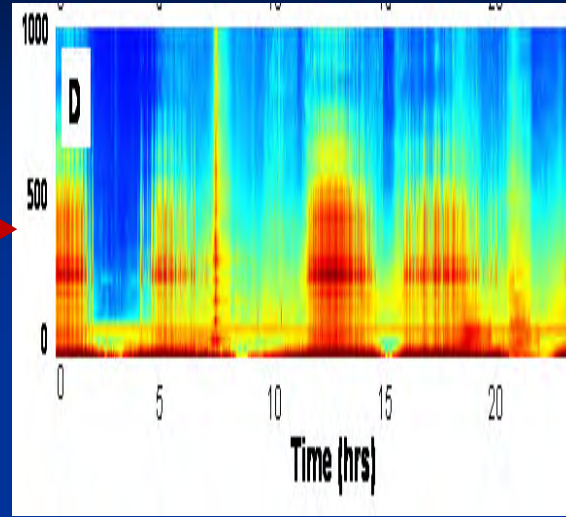

September 11, 2001

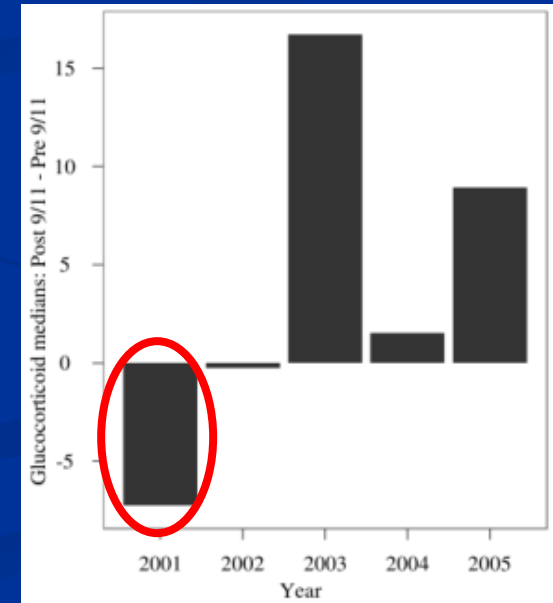
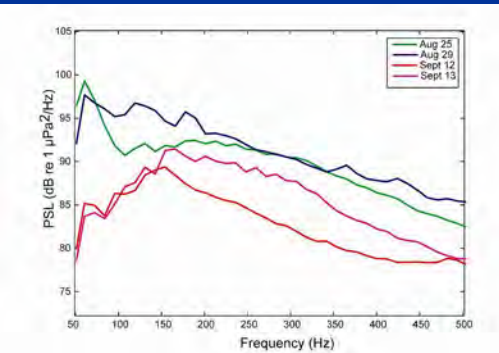

Evidence that ship noise increases stress in right whales

Rosalind M. Rolland, Susan E. Parks, Kathleen E. Hunt, Manuel Castellote, Peter J. Corkeron, Douglas P. Nowacek, Samuel K. Wasser and Scott D. Kraus

Proc. R. Soc. B published online 8 February 2012
doi: 10.1098/rspb.2011.2429

Habitat monitoring

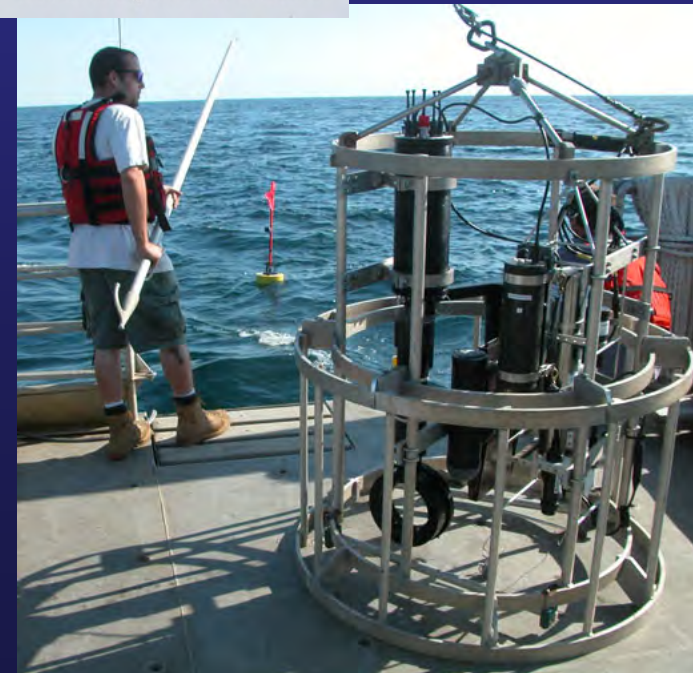
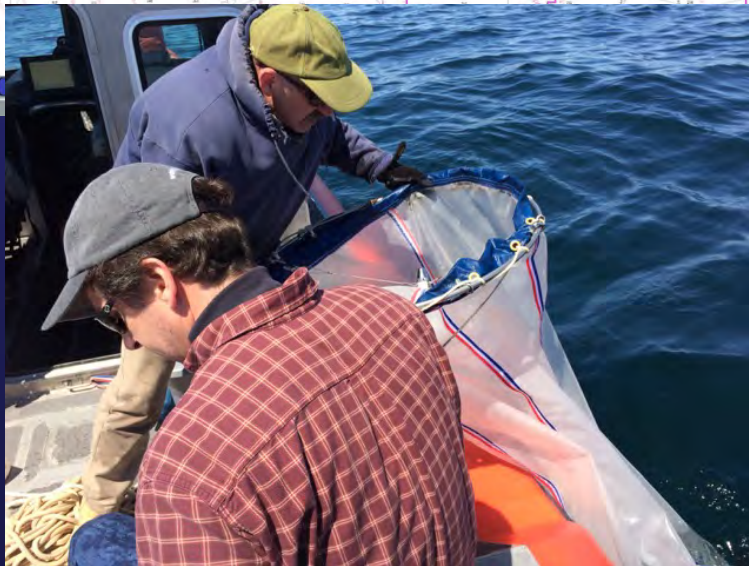
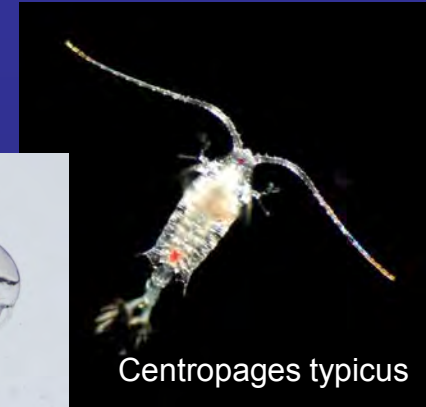
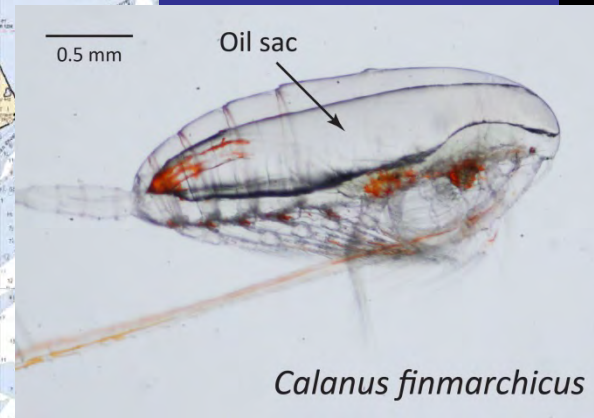
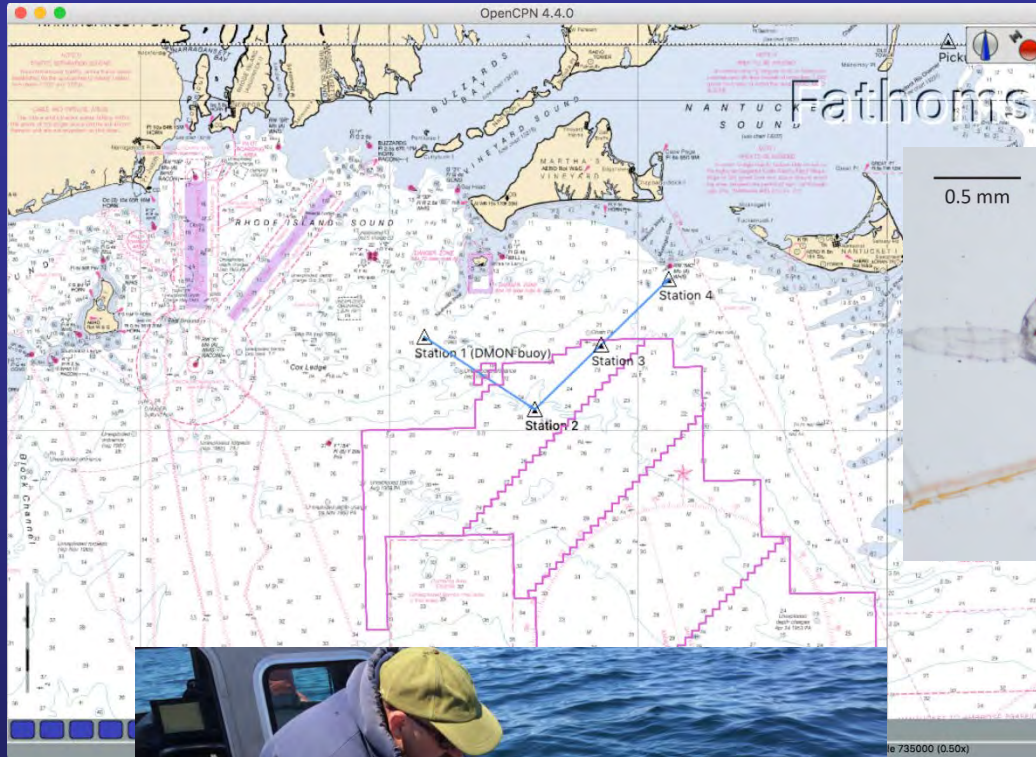



BOEM
BUREAU OF OCEAN ENERGY MANAGEMENT

Offshore Wind Energy Development

Short term impacts

Dr. Desray Reeb, Marine Biologist
Office of Renewable Energy Programs
Desray.Reeb@boem.gov



Regulatory Responsibilities

- An Environmental Assessment (EA) under the National Environmental Policy Act (NEPA) is a concise public document that provides **sufficient evidence and analysis** for determining whether BOEM should issue a Finding of No Significant Environmental Impact (FONSI) or prepare an Environmental Impact Statement (EIS)
 - **National Environmental Policy Act of 1969** | *Pub L. 91-190*
- The purpose of a biological assessment is to **evaluate the potential effects** of the action on listed and proposed species and designated and proposed critical habitat and determine whether any such species or habitat are likely to be adversely affected by the action.
 - **Endangered Species Act of 1973** | *16 U.S.C. §1531 et seq.*

Regulatory Responsibilities

- Response to stakeholders



What is a short term impact?

- Covering or applying to a **relatively** short period
- Immediate to 1 yr?
- Noticeable, but temporary, change in e.g. distribution, behavior, physiology



What do we know?

Construction

- **Harbor porpoise**
- Show varied levels of displacement during construction
 - Ranging from weeks to months to years (Teilmann and Carstensen, 2012)
 - In some instances, post construction detections were higher than before (Scheidat et al., 2011)
- **Seals**
- Varied responses between species, some stay some go (Caltrans, 2001)
- Post-construction use of turbines for foraging (Russell et al., 2014)

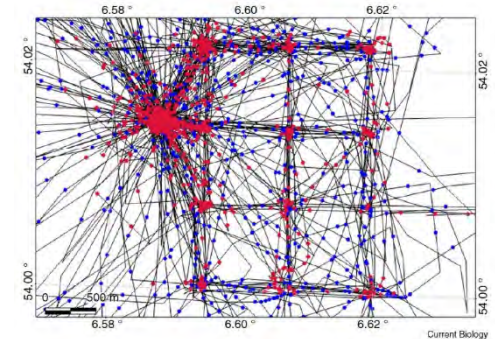

The challenge – what we don't know

- What are the short term impacts (positive/negative) from pile driving on large whales and sea turtles?
- What significance will any short term impacts have on large whale and sea turtle populations?
- Can short term impacts be measured? If so, how?

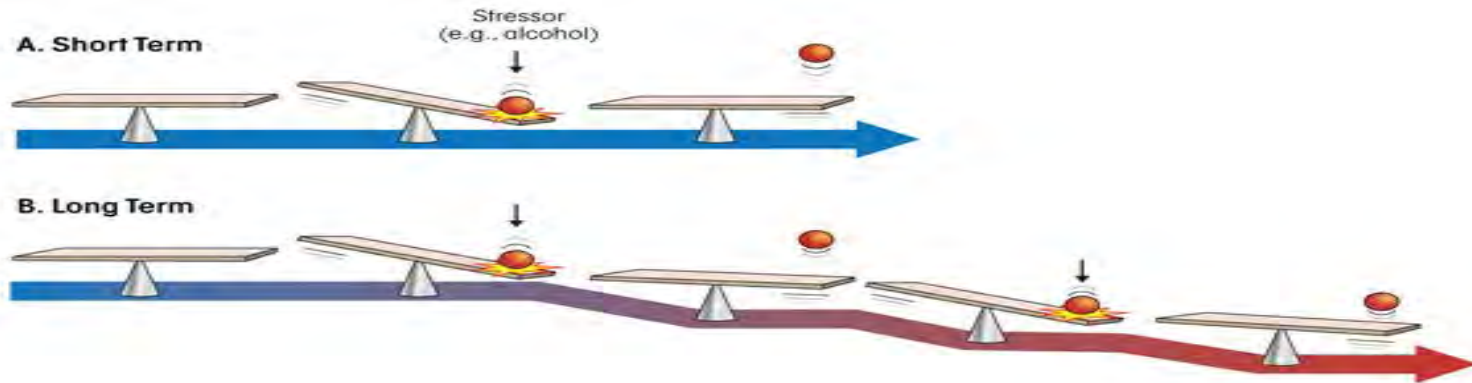

Where to from here?

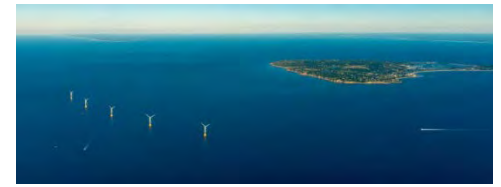

- Baseline/Current status data: Seasonal abundance and distribution, and ambient noise levels.
- Characterization of the sources, particularly pile driving: Standardized approaches for both predicting then measuring/verifying noise measurements.
- Responses of marine mammals to pile driving: Develop a standardized approach (research plan) to monitoring so we can to compare future projects. Standardized methods of empirical data collection are needed.
- PCoD: Interest in the parameters of PCoD models as potential monitoring requirements to detect any potential effects of wind facility development on marine mammals.
- Where should we be looking, that we aren't yet?

Thank you



What is our current understanding of long-term impacts?

Kyle Baker, Marine Biologist
Bureau of Ocean Energy Management, Office of Renewable Energy Programs

- How is a long-term impact defined?
- Assessment of long-term impacts
- Scale/scope
- Key actors

What is a Long-Term Impact?

- No regulatory definition
- *Reasonably foreseeable*
- A stressor (*stressor and effect*)
- Has a location
- Has time elements (when and how long (single, intermittent, continuous))
- Has an intensity level
- Has observable components (stressors, effects, intensity)

What is a Long-Term Impact?

- Beneficial or adverse
- Direct or indirect
- Incremental or synergistic
- Uncertainty is certain
- All the above informs monitoring strategies

Assessing Long-Term Impacts

What we know we know

- Information is available on species and habitat (we have baseline!)
- Effects have been observed
- May include other regions or similar types of impacts

What we know we don't know

- Little information is available
- Novel stressors and/or effects
- Surrogate species

Unknown Impacts

- Unchartered waters

Long-Term Effects: Foundations

Habitat Alteration: Concern for long-term impacts to habitat use of large whales.

- What are the affected habitat elements?
- What are other factors affecting inter-annual variation?
- What “use” factor is measured: migration, abundance, residence periods?

Long-Term Effects: Foundations

Reef Effect:

- Structures may support marine communities
- Increase in biomass or redistribution of biomass in area
- Community composition
- Attraction of listed species (feeding/sheltering of sea turtles)
- Haul-out and foraging opportunities for seals (Russel et al. 2014; Delefosse et al. 2017)
- Effects may occur later or change over time
- Beneficial or neutral effects?

Long-Term Effects: Foundations

Reef Effects

- Attract charter boat and recreational fishers
- Snagged, cut, and lost gear
- Increased monofilament, hooks, and other jettisoned debris
- Ingestion and entanglement possible
- Decreased health, potential mortality, and strandings
- Risk and impact level uncertain

Long-Term Effects: Vessel Traffic

- Permanent changes to shipping patterns
- Will traffic patterns shift to higher density areas?

Long-Term: Cables and EMF

- Comments on direct effects to navigation interference, strandings
- Long-term, but localized impact (up to 10s of meters)
- Intensities of EMFs by DC undersea power cables may be detected by sea turtles within the vicinity of 50 m above and out to 68 m horizontally from the cables (OCS Report 2011-09)
- Impact possible, but not known if EMF has any effect on turtle behavior
- May be an attraction effect on sensitive species (e.g., elasmobranchs), but
- No effects on marine mammals reported
- More study might be warranted for full scale commercial facilities

Long-Term Effects: Turbine Noise

Turbine Noise

- Long-term impact of continuous, low frequency sound
- Concern for direct effects on behavior, masking, strandings
- Highest reported SPL from measured turbines (Denmark and Sweden) across all 1/3-octave bands was 127 dB re 1 uPa
- Much lower SPL at 70 Hz from Block Island (RODEO unpublished data) from newer direct drive turbines
- Comments received on potential impact of numerous turbines operating in large projects versus 5 at Block Island
- We likely need to continue measurements

Long-Term Effects of Pile Driving: What we think we might know

Vulnerable populations are present

- Species are highly migratory across many wind areas
- Porpoises are vulnerable to foraging stress (Hoekendijk et al. 2018) and disturbance (Tougaard et al. 2003, 2005, 2007; Carstensen et al 2006)
- Right whale low numbers
- Larger populations or stocks may also be vulnerable and more easily monitored
- Species occur over large ranges across many wind energy areas

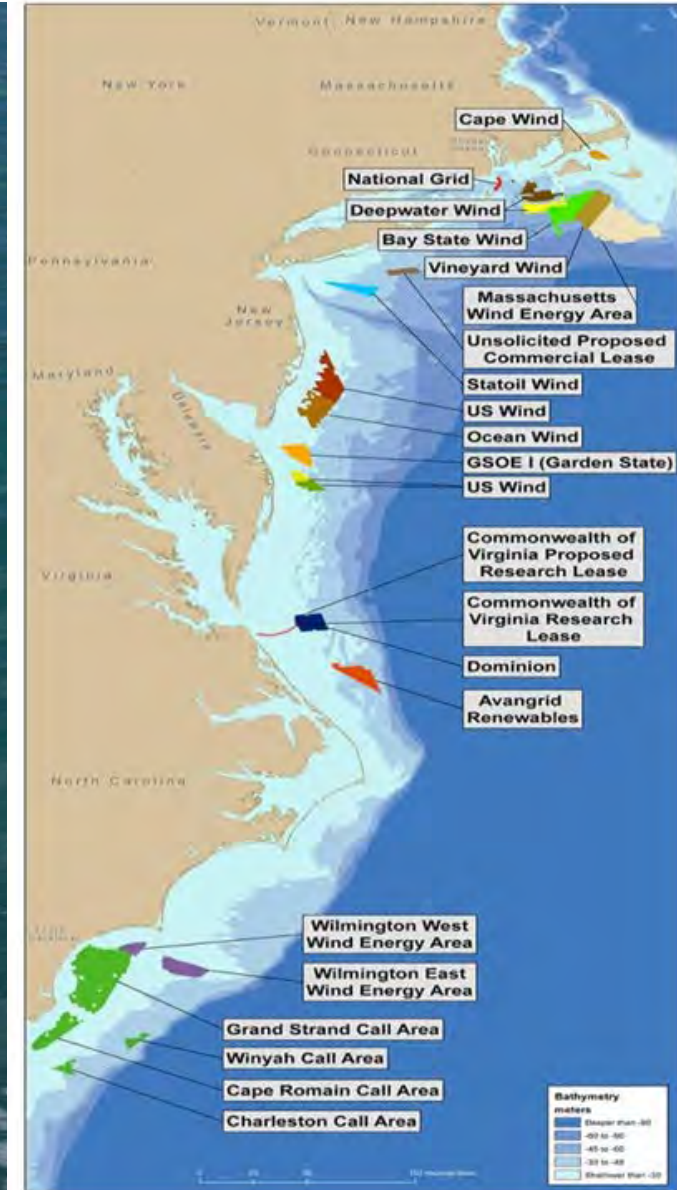

Long-Term Effects of Pile Driving: What we think we might know

- Long-term (many days over consecutive months)
- Multiple years in in the North and Mid-Atlantic
- Possibly piling at multiple projects
- Need comparable methods among wind sites
- Project-specific studies will occur, but
- The strategy needs to consider all wind areas
 - Health assessments can occur anywhere
 - Calf counts
 - migratory questions
 - Noise measurements need to be comparable
 - Data needs to be shared

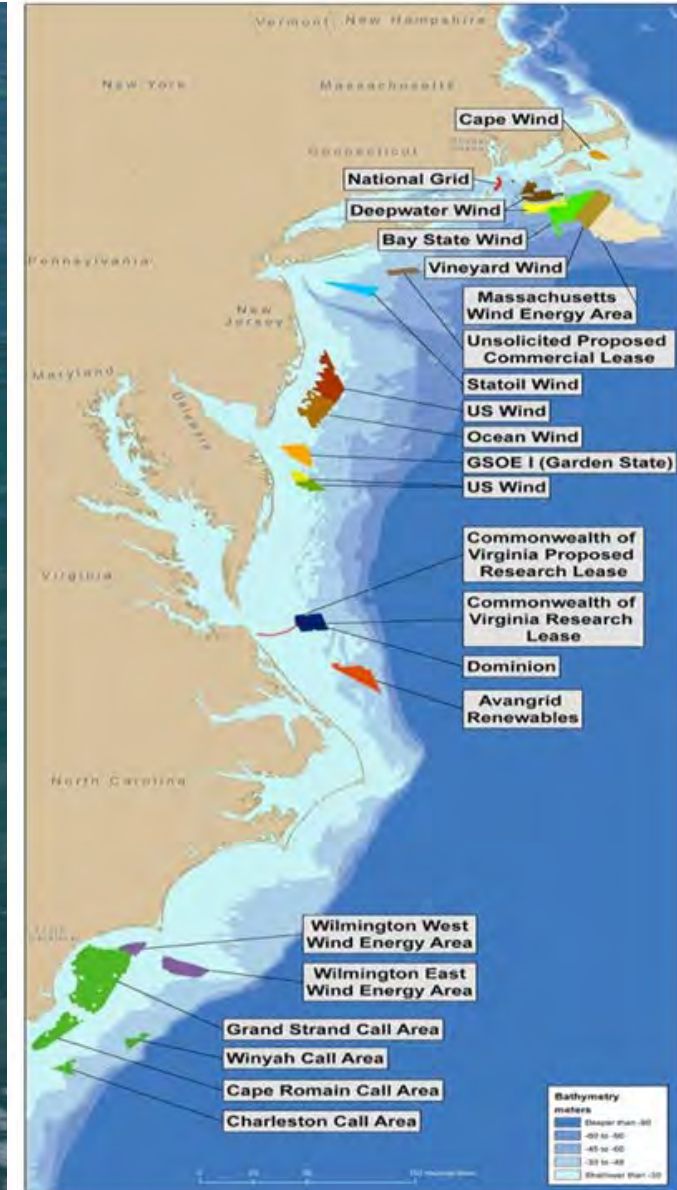

Long-Term Effects: Pile Driving

- Energetic consequences of being displaced from important feeding areas
- Energetic consequences of finding a new foraging patch
- Can animals compensate or what are the consequences of not meeting daily caloric needs
- Consequences of exposure from multiple wind farms, maybe same time
- PCoD available for some species (e.g., porpoises, sperm whales), but data gaps and uncertainty about effects
- What are our best indicators that can be measured?

Long-Term Effects

What are the reasonably certain to occur impacts?

Where will they occur?

Over what time scales will they occur?

How intense will effects be (magnitude)?

Incremental or synergistic effects?

Potential Variables and Indicators

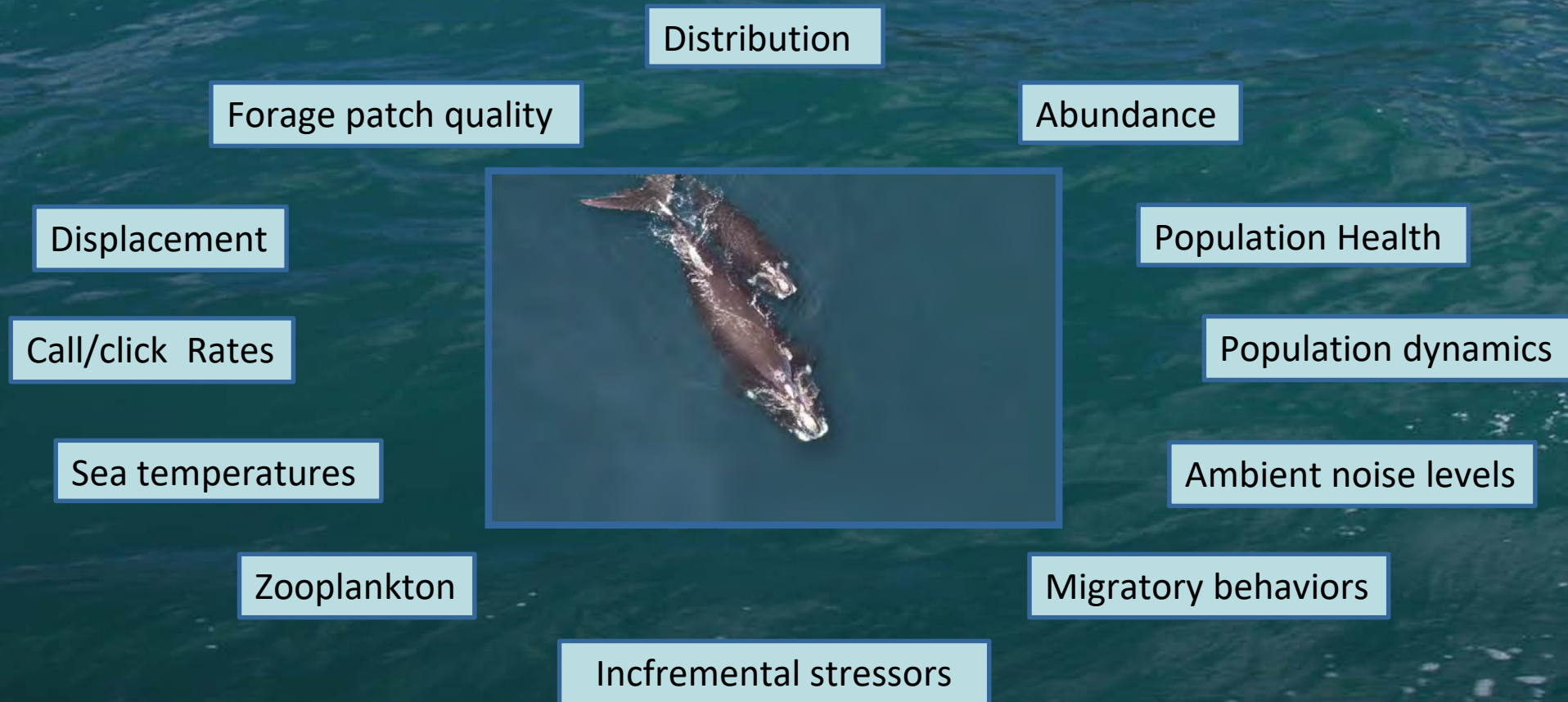

Key Actors for Navigating an Atlantic Strategy

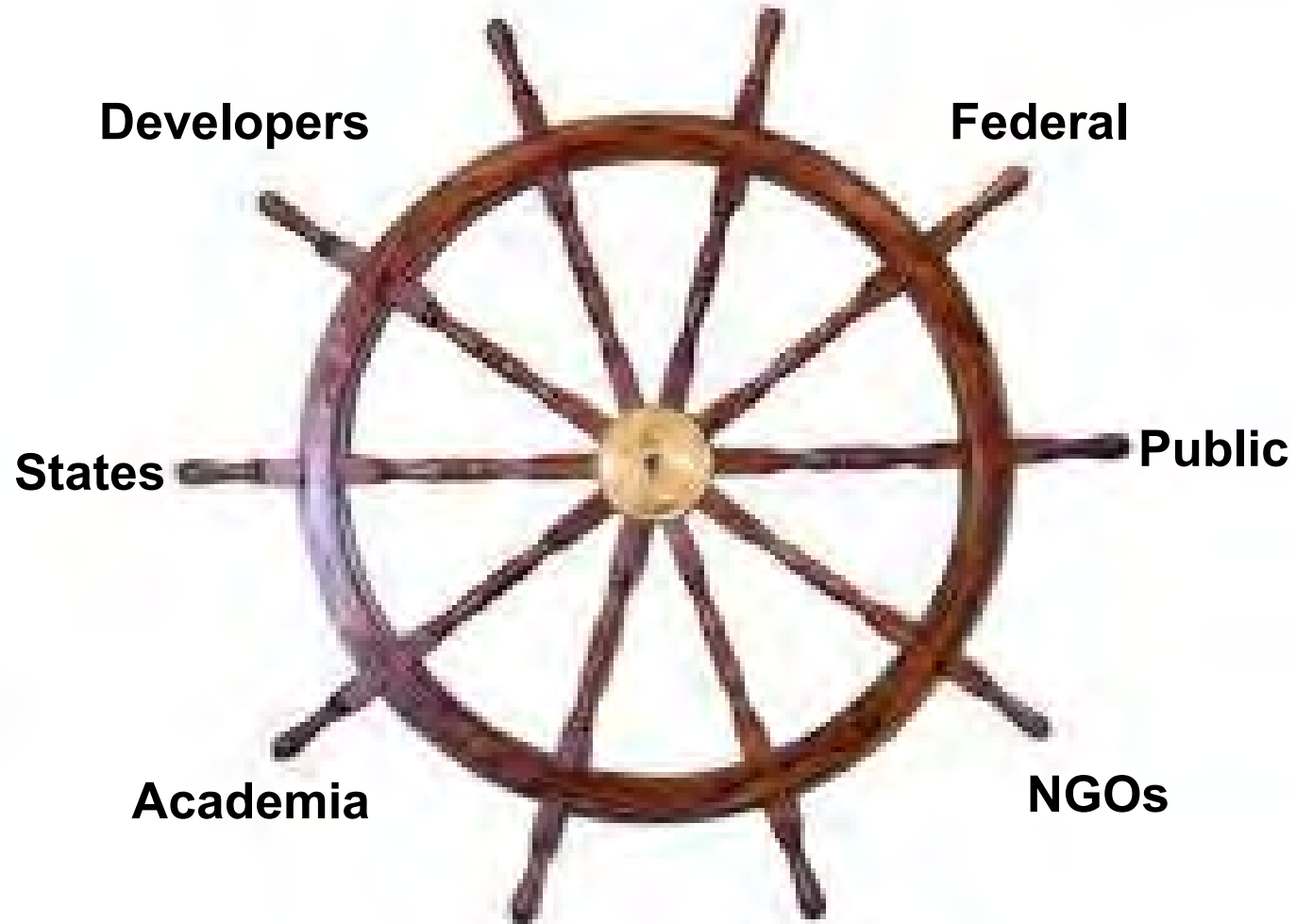

Overview: Offshore Wind Construction

Tyler Studds
Senior Manager Offshore Wind Sector Development
Massachusetts Clean Energy Center

Offshore Wind Foundation Types

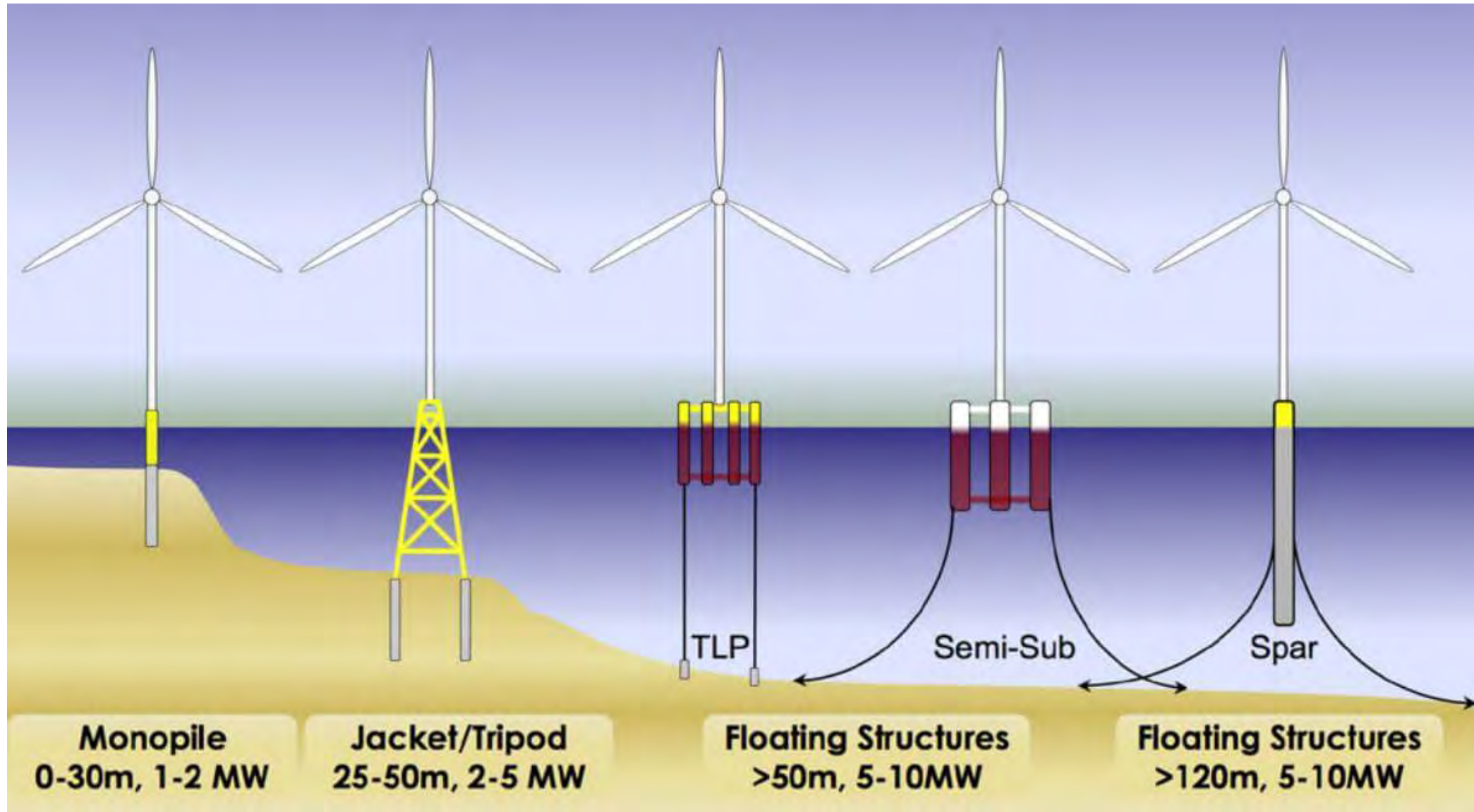

10 m Monopile

Cylindrical pipe section with a diameter of **10 m** produced from one plate of 31.4 m long, 3 m in wide, and 95 mm thick.





Jackets



Jacket Installation - Piles

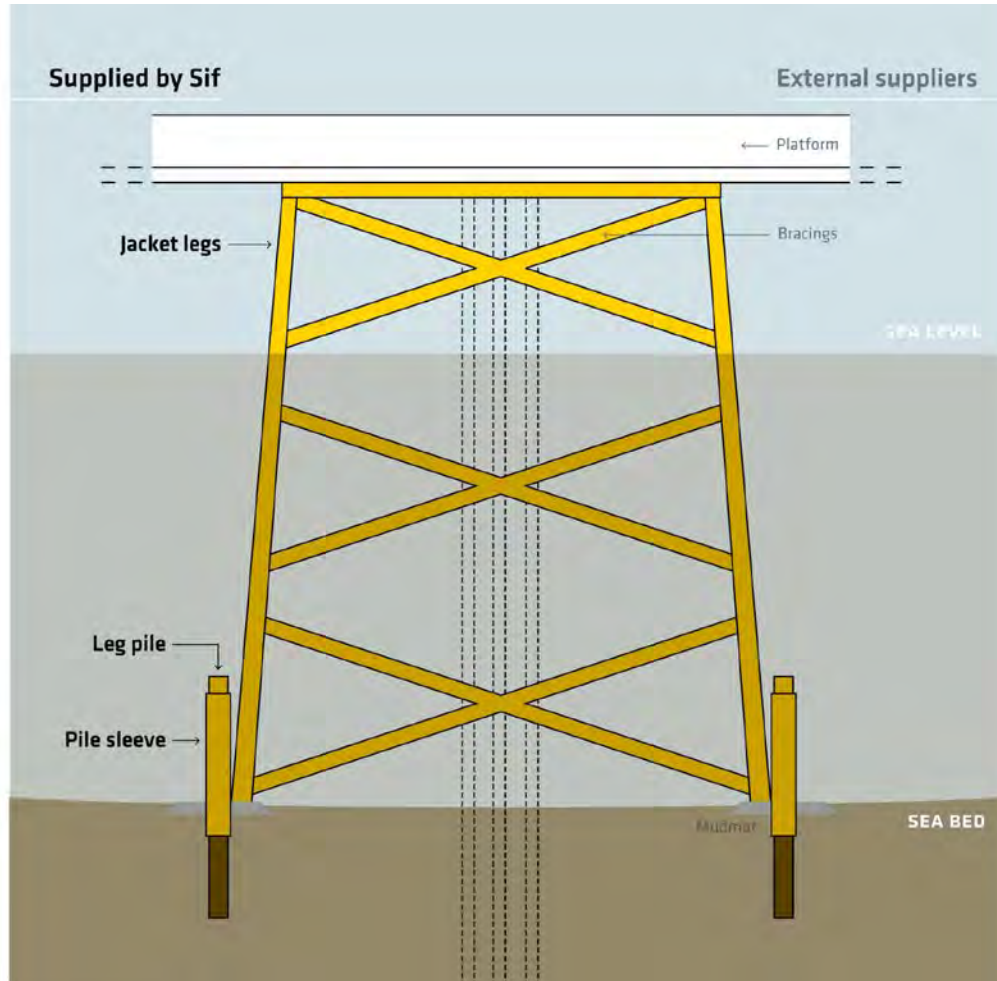

Jacket Installation – Suction Bucket



Gravity Based Foundation



Transition Piece



Installation Vessels



Installation Sound Mitigation – Bubble Curtain



Substations



Courtesy TenneT TSO GMBH

Transmission

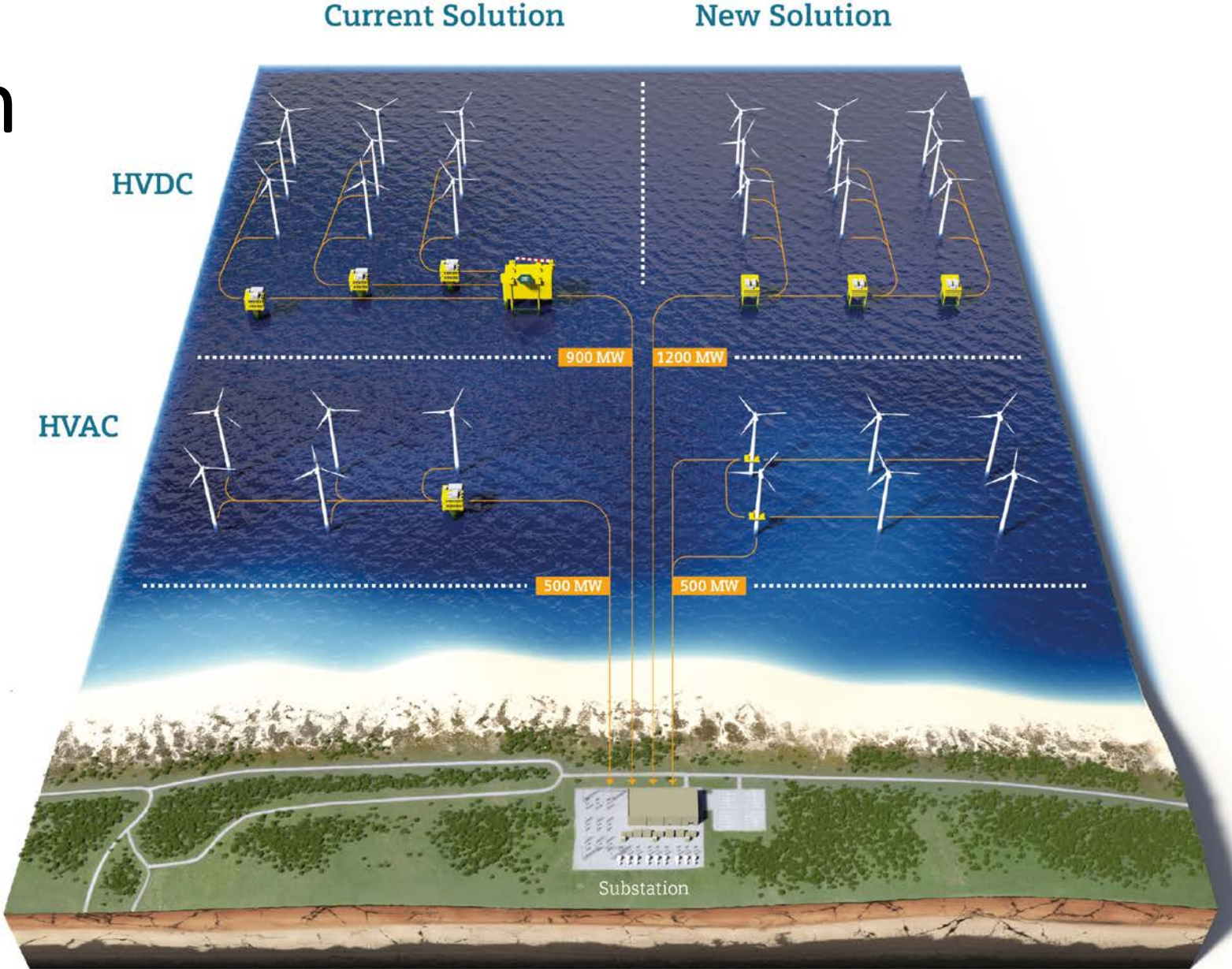

Cable Installation

