

# Construction & Operations Plan

## Ocean Wind Offshore Wind Farm

Volume I

May 18, 2023

Submitted to:



Submitted by:



Prepared by:



# **Ocean Wind Offshore Wind Farm**

## **Construction and Operations Plan VOLUME I**

**May 2023**

# Document Version

File Name	Preparer	Editor	Checker	Accepter	Approver
OCW01_COP_Volume I_20230518.doc	PB, LW	AD	SZ, JD	MEGAL	KAPER

---

**CONTAINS CONFIDENTIAL INFORMATION**

*Certain information included in this Construction and Operations Plan (COP) qualifies as trade secrets and/or commercial or financial information that is privileged and confidential, and which is exempt from public disclosure under the Federal Freedom of Information Act (5 United States Code [U.S.C.] § 552(b)(4)) (as reflected in the Bureau of Ocean Energy Management's [BOEM's] regulations at 30 Code of Federal Regulations [CFR] §§ 585.113 and 585.620). This privileged and confidential information is also exempt from public disclosure under the New Jersey Open Records Act (pursuant to New Jersey Administrative Code [N.J.A.C.] 47:1A), New Jersey Administrative Code 7:1D-3, National Historic Preservation Act (16 U.S.C. Part 470w-3) and the Archaeological Resources Protection Act of 1979 (16 U.S.C. Part 4702-3).*

*Ocean Wind LLC has marked each Appendix in this COP which contains privileged and confidential material with the legend "Contains Confidential Information", and requests that BOEM (and each federal and state agency to which a copy of this COP is provided) withhold these designated materials from public disclosure.*

# Construction and Operations Plan - Overall Outline

## **Volume I**

### Executive Summary

1. Project and Proponent Information Overview
  - 1.1 Ocean Wind LLC
  - 1.2 Introduction
  - 1.3 Commercial Lease Stipulations and Compliance
2. Regulatory Framework and Stakeholder Outreach
  - 2.1 Required Information in COP
  - 2.2 Permits and Authorizations
  - 2.3 Stakeholder Outreach
3. Ocean Wind's Purpose and Need of the Proposed Action
4. Project Description
  - 4.1 Ocean Wind Project Location
  - 4.2 Design Envelope Approach
  - 4.3 Project Infrastructure Overview
  - 4.4 Project Key Parameters
  - 4.5 Schedule
  - 4.6 Phased Development
5. Project Development, Route Planning, and Site Selection
  - 5.1 Project Screening and Siting
  - 5.2 Design Alternatives Reviewed and Not Carried Forward
6. Project Infrastructure and Description of Activities
  - 6.1 Offshore Infrastructure and Activities
  - 6.2 Onshore Infrastructure and Activities
  - 6.3 Decommissioning Plan
7. Health and Safety
  - 7.1 Introduction
  - 7.2 Major Components of the Project SMS
  - 7.3 Cybersecurity
  - 7.4 Obstruction Lighting and Markings
8. Waste Management and Chemicals
  - 8.1 Chemicals
  - 8.2 Waste Management
9. Other Information
  - 9.1 Design Standards
10. References

## **Volume II**

1. Potential Impact Producing Factors, Applicant Proposed Impact Minimization Measures, and Summary of Project Impacts
  - 1.1 Potential Impact Producing Factors and Applicant Proposed Impact Minimization Measures
  - 1.2 Summary of Project Impacts
2. Existing Conditions, Potential Impacts, and Mitigation
  - 2.1 Physical Resources
    - 2.1.1 Geological Resources
    - 2.1.2 Water Quality

- 2.1.3 Air Quality
- 2.2 Biological Resources
  - 2.2.1 Terrestrial and Coastal Habitats
  - 2.2.2 Terrestrial and Coastal Fauna
  - 2.2.3 Birds
  - 2.2.4 Bats
  - 2.2.5 Benthic Resources
  - 2.2.6 Finfish and Essential Fish Habitat
  - 2.2.7 Marine Mammals
  - 2.2.8 Sea Turtles
- 2.3 Socioeconomic Resources
  - 2.3.1 Demographics, Employment, and Economics
  - 2.3.2 Environmental Justice
  - 2.3.3 Recreation and Tourism
  - 2.3.4 Commercial Fisheries and For Hire Recreational Fishing
  - 2.3.5 Land Use and Coastal Infrastructure
  - 2.3.6 Navigation and Vessel Traffic
  - 2.3.7 Other Marine Uses
- 2.4 Cultural, Historical, and Archaeological Resources
- 3. References Cited

**Volume III**

- Appendix A Emergency Response Plan, Including Oil Spill Response Plan  
*(Contains Confidential Information - Not for Public Disclosure)*
- Appendix B Safety Management System *(Contains Confidential Information - Not for Public Disclosure)*
  - B-1 Supplemental Waste Management Information
  - B-2 Supplemental Information Provided in Response to BOEM Comments
- Appendix C Certified Verification Agent Services  
*(Contains Confidential Information - Not for Public Disclosure)*
- Appendix D Ocean Wind Offshore Wind Farm (OCW01) Marine Site Investigation Report  
*(Contains Confidential Information - Not for Public Disclosure)*
- Appendix E Biological Survey Results  
*(Portions Contain Confidential Information - Not for Public Disclosure)*
- Appendix F Archaeology and Historic Properties Survey Report
  - F-1 Marine Archaeological Resources Assessment (MARA)  
*(Contains Confidential Information - Not for Public Disclosure)*
  - F-2 Terrestrial Archaeological Resources Assessment (TARA)  
*(Contains Confidential Information - Not for Public Disclosure)*
  - F-3 Assessment of Visual Effects on Onshore Historic Properties
  - F-4 Historic Properties Treatment Plan
  - F-5 Terrestrial Post-Review Discoveries Plan, Marine (Submerged) Post-Review Discoveries Plan  
*(Contains Confidential Information - Not for Public Disclosure)*
- Appendix G Locations for Offshore Turbines and Substations
- Appendix H Assessment of the Potential Effects of the Ocean Wind Offshore Wind Farm on Birds & Bats
- Appendix I Atlantic Sturgeon Supplementary Material
- Appendix J Marine Mammal Supplementary Material
- Appendix K Sea Turtle Supplementary Material

Appendix L	Visual Impact Assessment
Appendix M	Navigation Safety Risk Assessment
Appendix N	Air Quality Analysis
	<i>(Contains Confidential Information - Not for Public Disclosure)</i>
Appendix O	Fisheries Communication and Outreach Plan
Appendix P	Technical Information to Support the Essential Fish Habitat (EFH) Consultation
Appendix Q	Coastal Zone Consistency Assessment
Appendix R	Noise Supplementary Material
	R-1 Over-air Noise Supplementary Material
	R-2 Underwater Noise Supplementary Material
Appendix S	BOEM's Best Management Practices
Appendix T	Departure Request and Supplemental Filing Schedule
Appendix U	Conceptual Plans and Typical Design Drawings
	<i>(Contains Confidential Information - Not for Public Disclosure)</i>
Appendix V	Environmental Justice Supplementary Material
Appendix W	Metocean Monitoring Information
Appendix X	Munitions and Explosives of Concern (MEC) and Unexploded Ordnance (UXO) Supplemental Information
	<i>(Contains Confidential Information - Not for Public Disclosure)</i>
	X-1 Munitions and Explosives of Concern (MEC) and Unexploded Ordnance (UXO) with Risk Assessment and Risk Mitigation Strategy
	X-2 MEC Pre-Installation Geophysical Survey Specification
	X-3 Supplementary UXO Information for Orsted Wind Farm Construction, US East Coast
Appendix Y	Site Conditions Assessment
	<i>(Contains Confidential Information - Not for Public Disclosure)</i>
Appendix Z	Design Feasibility Study
	<i>(Contains Confidential Information - Not for Public Disclosure)</i>
	Z-1 Foundation Feasibility Study
	Z-2 Cable Burial Feasibility Assessment
Appendix AA	Protected Species Mitigation and Monitoring Plan (PSMMP)
Appendix AB	Avian and Bat Post-Construction Monitoring Framework
Appendix AC	Wetland Delineation Report
Appendix AD	Airspace and Radar Analysis
Appendix AE	Fisheries Mitigation Efforts

## Executive Summary

This Ocean Wind Offshore Wind Farm Construction and Operations Plan (COP) is being submitted by Ocean Wind LLC (Ocean Wind), an affiliate of Orsted Wind Power North America LLC (Orsted), to support the siting and development of the Ocean Wind Offshore Wind Farm Project (OCW01, Offshore Wind Farm, or Project). The Project is being developed pursuant to the Bureau of Ocean Energy Management (BOEM) requirements for the Ocean Wind BOEM Lease Area OCS-A 0498 Commercial Lease of Submerged Lands for Renewable Energy Development on the Outer Continental Shelf (Lease).

The Project includes up to 98 wind turbine generators (WTGs), up to three offshore alternating current (AC) substations, array cables linking the individual turbines to the offshore substations, substation interconnector cables linking the substations to each other, offshore export cables, an onshore export cable system<sup>1</sup>, two onshore substations, and connections to the existing electrical grid in New Jersey (underground cables or overhead transmission lines would be required to connect each onshore substation to the existing grid). The WTGs and offshore substations, array cables, and substation interconnector cables will be located in Federal waters approximately 13 nautical miles (nm, 15 statute miles) southeast of Atlantic City. The offshore export cables will be buried below the seabed surface within Federal and State waters. The onshore export cables, substations, and grid connections are intended to be located in Ocean, Atlantic, and/or Cape May Counties, New Jersey. The Project location is depicted in **Figure 1.1-1**. Project construction will begin in 2023, and the Project is scheduled to deliver first power in late 2024 or early 2025.

The operation phase of the Project will include the use of an onshore operations and maintenance (O&M) facility in Atlantic City, NJ. The O&M facility will serve as a regional operations and maintenance center for multiple projects that Orsted intends to develop in the mid-Atlantic. Marina upgrades, namely dredging in the marina and at Absecon Inlet, would benefit multiple marina users, and both this activity and upland improvements are not dependent upon approval of the Project and are being separately reviewed and authorized by the USACE. This work would be completed in advance of, and is not dependent upon, approval of the Project.

Following consultation with BOEM, it was agreed that Ocean Wind would use the design envelope approach for the Project presented and analyzed in this COP. The design envelope approach allows BOEM to review and analyze the maximum impacts that could occur from a range of designs. The design envelope approach has been taken throughout the COP to allow meaningful assessment of the Project to proceed, while still allowing reasonable flexibility for future Project design decisions.

The purpose of the Project is to develop an offshore wind generation project within the BOEM Lease Area (OCS-A 0498, Lease Area), to deliver competitively priced renewable energy and additional capacity to meet State and regional renewable energy demands and goals. The Project meets New Jersey's need to fulfill the State's Offshore Wind Economic Development Act, which mandates the development of a minimum of 1,100 megawatts (MW) of offshore wind resources. The Project also contributes to meeting the need established by both NJ Executive Order 8, which set a goal for 3,500 MW of renewable energy by 2030, and Executive Order 92, which in November 2019 increased the goal to 7,500 MW by 2035. In September 2022, Executive Order 307 increased New Jersey's offshore wind energy goal by nearly 50 percent to 11,000 MW by 2040.

The COP describes how Ocean Wind will develop and operate the Project in a manner that conforms to responsible offshore development, which includes the application of best management practices.

Specifically, this COP includes:

---

<sup>1</sup> The onshore export cable system will include the onshore export cable, transition joint bays, onshore splice vaults/grounding link boxes and fiber optic system, including manholes.



- An overview of the Project and proponent; a description of the regulatory framework within which the Project will be reviewed; a summary of stakeholder outreach; a statement of Ocean Wind’s purpose and need for the Project; the Project description; a description of the Project development, route planning, and site selection, a description of all planned facilities and all proposed construction, operation, and conceptual decommissioning activities (Volume I).
- A summary of impact producing factors (IPFs) associated with the Project; applicant proposed measures (APMs) to avoid, minimize and mitigate potential impacts; and characterization of the existing environmental and assessment of potential impacts during construction, operation, and decommissioning (Volume II).
- Appendices with survey results, plans, supplementary information, and detailed studies as needed to support review of the Project (Volume III).

**Table ES-1** provides a summary of the IPFs (See Volume II, **Table 1.1-1**) and potential environmental impacts associated with the Project. Volume II provides a detailed assessment of the potential impacts as well as the APMs to avoid, minimize, and mitigate for potential impacts.

The Project’s benefits include the following:

- Contributing to meeting state renewable energy goals and replacing fossil fuel-based energy sources;
- Improving regional air quality through the net reduction of regional air pollution over the life of the Project;
- Creating artificial reefs through the placement of WTGs, which will create hard substrate habitats for a new, more diverse community of finfish and invertebrates; and
- Increased job opportunities, increased property tax revenue, and increased income associated with local construction employment. Long-term employment opportunities during the operations phase would include the creation of operations and maintenance jobs. Artificial reefs are expected to increase the number of trips and revenue for recreational fishermen.

**Table ES-1. Summary of primary potential Project impacts.**

Resource	Summary of Primary Potential Impacts <sup>2</sup>
Geology	<p>The IPFs affecting geological resources include physical seabed/land disturbance, and sediment suspension.</p> <p>Permanent impacts would result from placement of facilities/structures or associated scour and cable protection on the seabed or soils. Specifically, offshore, the facility foundations, scour protection, and limited cable protection are expected to result in long term or permanent changes to the seabed, including the benefit of added hard bottom habitat. Onshore, the substation facilities, transition joint bays (TJBs), and splice vaults/grounding link boxes are expected to result in permanent impacts to soils. Temporary impacts would result from sediment and soil removal or displacement and re-suspension. Impacts to geological resources would be minimized with the application of APMs.</p>
Water Quality	<p>The IPFs affecting water quality include physical seabed/land disturbance, sediment suspension, and discharge/releases and withdrawals.</p> <p>No long-term impacts to water quality are anticipated. Impacts to water quality are expected to be localized, temporary, and short-term with the application of APMs. Seabed disturbance for offshore construction and O&amp;M activities will result in temporary increases of suspended sediment. Potential discharges will be in conformance with required federal, state and local approvals. Potential contamination may occur from unforeseen spills or accidents, and any such occurrence will be reported and addressed in accordance with the local authority.</p>

<sup>2</sup> Applicant proposed measures are summarized in Volume II, Section 1.1, Table 1.1-2.

Resource	Summary of Primary Potential Impacts <sup>2</sup>
Air Quality	<p>The IPFs affecting air quality include air emissions and traffic.</p> <p>The Project itself would have long-term beneficial impacts as it is an air quality impact avoidance measure that would result in a long-term net reduction of regional air pollution over the life of the Project through displacement of fossil fuel-generated power plants. Other potential impacts are short-term. Short term impacts include emission of air pollutants during construction, operations and maintenance, and decommissioning phases. Primary categories of air emission sources include the following: marine vessels, generators (backup power/emergency generators), and non-road engines. Short-term impacts to air quality would result from fugitive dust and emissions from Project equipment and vessels associated with construction related activities and on a smaller scale with operations-related activities.</p>
Terrestrial and Coastal Habitats	<p>The IPFs affecting terrestrial and coastal habitats include physical seabed/land disturbance, discharge/releases and withdrawals, habitat conversion, and suspended sediment.</p> <p>The onshore substation facilities will result in long-term, permanent impacts to previously disturbed habitat, and where tree clearing is required, habitat will be converted to non-forested. Other impacts to terrestrial and coastal habitats are expected to be localized, temporary, and short-term with the application of APMs. Onshore coastal and terrestrial habitats may experience temporary disturbance from construction and installation activities, including clearing and grading, trenchless cable installation (such as horizontal directional drilling [HDD], direct pipe, and auger bore), open trench excavation, onshore substation construction, equipment and construction staging, and potential contamination from spills.</p>
Terrestrial and Coastal Fauna	<p>The IPFs affecting terrestrial and coastal fauna include physical seabed/land disturbance, habitat conversion, noise, traffic, suspended sediment, and electromagnetic fields (EMF).</p> <p>While the onshore substation facilities will result in permanent impacts to previously disturbed habitat, it is expected that the direct loss of habitat for most faunal species would be minimal because the direct loss of habitat is small compared to available adjacent habitat. Other impacts to terrestrial and coastal fauna are expected to be localized and temporary with the application of APMs. For example, short term impacts on wildlife are expected to occur as a result of temporary habitat disturbance and increased noise and traffic from construction. Construction noise and traffic associated with the Project would typically be temporary and consistent with current levels of traffic. O&amp;M noise and traffic disturbances would be limited to specific areas and would occur over shorter periods of time than during construction.</p>
Birds	<p>The IPFs affecting birds include habitat conversion, noise, visible structures/lighting, and traffic.</p> <p>During operation, the long-term potential impacts are collision with Project structures and habitat loss due to displacement, but population level impacts are unlikely. Long-term onshore habitat loss impacts are expected to be limited because substations will be co-located in existing disturbed areas and export cables will generally be buried. If the overhead transmission line option is selected for the connection between an onshore substation and interconnection point, this portion of the transmission lines will be built, to the extent practicable, following the Avian Power Line Interaction Committee (APLIC) standard design guidance. The guidance includes designing the lines to meet or exceed minimum clearance distances to minimize/eliminate the risk of electrocution; and marking wires with bird diverters to make wires more visible to minimize collision risk. Potential temporary construction impacts include onshore habitat modification and disturbance.</p>
Bats	<p>The IPFs affecting bats include physical land disturbance, habitat conversion, noise, visible structures/lighting, and traffic.</p> <p>During operation, the long-term potential impacts are collision with Project structures and habitat loss due to displacement. Long term or permanent habitat loss would occur if trees providing bat habitat are removed, but this is expected to be very limited as practicable as facilities will be co-located in existing disturbed areas. Potential temporary, short-term construction impacts include habitat modification and temporary disturbance, which are expected to be localized and temporary with the application of APMs.</p>

Resource	Summary of Primary Potential Impacts <sup>2</sup>
Benthic Resources	<p>The IPFs affecting benthic resources include physical seabed/land disturbance, sediment suspension, discharge/releases and withdrawals, habitat conversion, noise, EMF, and vessel traffic.</p> <p>Permanent changes to benthic habitat will occur with the installation of WTG and offshore substation foundations, associated scour protection, and in areas along the cable corridors where additional cable protection is required. Installed foundations and scour or cable protection would have the benefit of offering hard substrate habitats for a new, more diverse community of finfish and invertebrates. Temporary, short-term sediment disturbing activities include pre-construction preparation of seabed (i.e., pre-lay grapnel surveys, potential in-situ unexploded ordnance/munitions and explosives of concern [UXO/MEC disposal]), pile driving for WTG and offshore substation foundations, installation of cables, anchoring and spudding, and leveling if necessary. These would primarily result in localized and temporary impacts, though they could result in mortality of sessile or slow-moving benthic organisms. Potential impacts would be minimized by implementing APMs.</p>
Fish and Essential Fish Habitat	<p>The IPFs affecting fish and essential fish habitat include physical seabed/land disturbance, sediment suspension, discharge/releases and withdrawals, habitat conversion, noise, EMF, and vessel traffic.</p> <p>Long-term habitat conversion would result from the introduction of hard bottom habitat associated with placement of scour protection and cable protection on the seabed, and from the introduction of structure within the water column due to WTG foundations. Newly-installed foundations, and scour and cable protection will offer beneficial hard substrate habitats for a new, more diverse community of finfish and invertebrates. Seabed disturbance could result in short-term suspended sediment/sedimentation and direct mortality of sessile or slow-moving organisms. Noise from vessels, pile driving, and potential in-situ UXO/MEC disposal will result in short-term impacts. Long-term impacts include tissue injury or mortality due to potential in-situ UXO/MEC disposal and direct burial or mortality due to foundation installation. These impacts would be minimized by implementing APMs.</p>
Marine Mammals	<p>The IPFs affecting marine mammals include physical seabed disturbance, noise, and traffic.</p> <p>Operation and maintenance of the Project may result in long-term impacts due to the potential for collision risks and disturbance associated with Project-related vessel traffic. Other potential impacts would be short-term. Specifically, potential temporary impacts to marine mammals would result from underwater noise associated with the construction of Project structures (e.g., pile driving, in-situ UXO/MEC disposal); construction related collision risks, noise, and disturbance associated with vessel traffic; and seabed disturbance resulting from construction, maintenance, or decommissioning activities. Temporary noise from pile driving is anticipated to be the most important IPF for marine mammals. Construction related direct impacts to marine mammals from UXO/MEC disposal activities during site preparation could include serious injury/mortality, acoustic harassment injury, acoustic harassment behavioral, and less likely behavioral harassment. Impacts would be minimized by implementing APMs, including developing a PSMMP in coordination with regulatory agencies.</p>
Sea Turtles	<p>The IPFs affecting sea turtles include physical seabed disturbance, noise, and traffic.</p> <p>Operation and maintenance of the Project may result in long-term impacts due to the potential for collision risks and disturbance associated with Project-related vessel traffic. Other potential impacts would be short-term. Specifically, potential temporary impacts to sea turtles would result from underwater noise associated with the construction of Project structures (e.g., pile driving, in-situ UXO/MEC disposal); construction related collision risks, noise, and disturbance associated with construction vessel traffic; and seabed disturbance resulting from construction, maintenance, or decommissioning activities. Construction related direct impacts to sea turtles from UXO/MEC disposal activities during site preparation could include serious injury/mortality, acoustic harassment injury, acoustic harassment behavioral, and less likely behavioral harassment. Impacts would be minimized by implementing APMs, including developing a PSMMP in coordination with regulatory agencies.</p>

Resource	Summary of Primary Potential Impacts <sup>2</sup>
Demographics, Employment, and Economics	<p>The IPFs affecting demographics, employment, and economics include noise, traffic, and land use and economic change.</p> <p>Increased job opportunities, increased property tax revenue, and increased income associated with local construction employment are benefits of the Project. Long-term employment opportunities during the operations phase would include the creation of operations and maintenance jobs. Potential impacts during construction are related to the temporary increased construction employment required for the Project and the impact these workers could have on population, public services, and temporary housing during construction; increased job opportunities; increased property tax revenue; and increased income associated with local construction employment.</p>
Environmental Justice	<p>The IPFs affecting environmental justice include air quality, noise, traffic, visible structures/lighting, and land use and economic change.</p> <p>The Project would not cause a disproportionate share of high and adverse environmental or socioeconomic impacts on any racial, ethnic, or socioeconomic group.</p>
Recreation and Tourism	<p>The IPFs affecting recreation and tourism include physical seabed/land disturbance, habitat conversion, noise, traffic, visible structures/lighting, land use and economic change, sediment suspension, and EMF.</p> <p>During Project operations, recreation and tourism activities are anticipated to be consistent with pre-existing conditions and result in slight long-term benefits on recreational fishing and other offshore recreation and tourism activities. Other impacts would be short-term. The noise, traffic, and visual impacts generated during construction activities may also temporarily deter recreation in the Offshore Project Area and the Onshore Project Area*. Access would only be restricted to isolated areas along the Offshore Project Area and Onshore Project Area during construction and maintenance activities. Operation and maintenance activities would also result in visible impacts, including lighting of the turbines, as required for maritime navigation and aviation safety.</p>
Commercial and For-Hire Recreational Fishing	<p>The IPFs affecting commercial and for-hire recreational fishing include physical seabed/land disturbance, habitat conversion, noise, traffic, land use and economic change, sediment suspension, and visible structures/lighting.</p> <p>WTGs and other in-water structures are expected to serve as long-term artificial reef structures, providing additional locations for for-hire recreational fishing trips, potentially increasing the number of trips and revenue. Other potential impacts are expected to be short-term. During construction of the facilities within the Wind Farm Area*, commercial and for-hire recreational fishing practices are expected to be temporarily disturbed. The offshore export cable route corridor avoids high density, high value commercial fishing grounds to the extent practicable. Ocean Wind adjusted the orientation of its WTG arrays in the southeast-northwest direction to align with and support the predominant commercial fishing transit routes out from Atlantic City. Very little for-hire recreational fishing occurs within the Wind Farm Area. Construction activities will result in temporarily displacing some recreational fishing trips to abundantly available fishing areas nearby.</p>
Land Use and Coastal Infrastructure	<p>The IPFs affecting land use and coastal infrastructure include physical seabed/land disturbance, discharge/release and withdrawals, noise, traffic, visible structures/lighting, and land use and economic change.</p> <p>Ocean Wind endeavors to locate Project components within land parcels that will avoid impacts or changes to the land use, such as within existing rights-of-way (ROWs), industrial zoned areas, and away from sensitive receptors and habitats where possible. However, some Project components may result in a long-term change to land use in the area where a Project component is constructed or long-term impacts to viewshed. During cable installation, short-term, temporary impacts could occur to in-water infrastructure at crossings of fiber optic cables, pipelines and other utilities. Ocean Wind will secure crossing agreements with utility owners to avoid permanent impacts.</p>

Resource	Summary of Primary Potential Impacts <sup>2</sup>
Navigation and Vessel Traffic	<p>The IPFs affecting navigation and vessel traffic include traffic, visible structures/lighting, and land use/economic change, all of which are long-term.</p> <p>Project structures will pose an allision and height hazard to vessels passing close by and vessels will pose a hazard to the structures. Spacing between WTGs in the evaluated layout provides sufficient sea room for maneuvering for vessel types expected to transit and fish in the Wind Farm Area. Project structures may serve as information navigation aids for mariners, particularly at night because they will be lighted and marked on navigation charts. Emergency rescue procedures will likely be adjusted to account for the Project structures once they are in place. In particular, helicopter-aided search and rescue will be a higher-risk activity in poor visibility, particularly within the Wind Farm Area. An estimated maximum of 0.1 search and rescue missions per year are anticipated in the Wind Farm Area based on the modeling results for allisions. However, this is a conservative estimate because most allision events do not require emergency rescue operations. Project structures with monopile foundations could sustain significant damage from an allision by a deep draft vessel at speed; immediate collapse is not anticipated. However, a jacket foundation is a weaker structure relative to horizontal loads. If the final foundation design for the offshore substation is a jacket, structural collapse from allision by a deep draft vessel at speed cannot be ruled out (jackets are not proposed for Project WTGs). Modeling shows it to be at most a 1-in-2,000-years event. The impacts on marine radar are variable, with the most likely effect being some signal degradation. Proximity to the WTGs is the primary factor that determines the degree of radar signal degradation</p>
Other Marine Uses	<p>The IPFs affecting other marine uses include traffic and visible structures/lighting.</p> <p>The air traffic control and national defense radar in the vicinity of the Project's proposed offshore facilities may be impacted by operation and maintenance phases of the Project. Potential impacts to military operations from vessel traffic are expected to be short-term and localized, and potential impacts to military operations from the permanent placement of structures within the water column and above the sea surface, within the Wind Farm Area, are expected to be long-term and localized. No other potential impacts are expected for other marine uses such as sand, gravel borrow and ocean disposal sites; and offshore energy sites.</p>
Cultural, Historical, and Archeological Resources	<p>The IPFs affecting cultural, historical, and archeological resources include physical seabed/land disturbance and visible structures/lighting.</p> <p>The above water Wind Farm Area infrastructure has the potential to affect the visual character defining feature of historic properties. Seabed disturbance may potentially impact submerged cultural resources. The onshore cables may potentially impact buried cultural resources, though this will be minimized because the onshore export cables are expected to be predominantly buried within existing ROW.</p>

\* Project Area - area occupied by the Project, including the Wind Farm Area, offshore export cable route corridors, onshore export cable route corridors, onshore substation and grid interconnection.

Wind Farm Area – Lease Area occupied by the WTGs, offshore substations, interconnector cables, part of the offshore export cables, and array cables.

Offshore Project Area - Wind Farm Area and offshore export cable route corridors.

Onshore Project Area - onshore Project components including the landfall, onshore export cable route corridors, onshore substation, and grid interconnection.

# Table of Contents

1.	Project and Proponent Information Overview .....	22
1.1	Ocean Wind LLC .....	22
1.1.1	About the Applicant .....	22
1.1.2	Contact Information .....	23
1.1.3	Designation of Operator .....	23
1.1.4	Financial Assurance .....	23
1.1.5	Certified Verification Agent Nomination.....	23
1.2	Introduction.....	23
1.3	Commercial Lease Stipulations and Compliance .....	26
2.	Regulatory Framework and Stakeholder Outreach .....	28
2.1	Required Information in COP .....	28
2.1.1	Location of Required Information in COP .....	28
2.1.2	Departure Requests .....	37
2.2	Permits and Authorizations.....	37
2.2.1	Regulatory Framework .....	37
2.3	Stakeholder Outreach.....	44
3.	Ocean Wind's Purpose and Need of the Proposed Action.....	60
4.	Project Description .....	61
4.1	Ocean Wind Project Location .....	62
4.1.1	Boundary .....	62
4.1.2	The Lease Area and Location Plat .....	62
4.2	Design Envelope Approach.....	66
4.3	Project Infrastructure Overview .....	66
4.4	Project Key Parameters.....	68
4.5	Schedule.....	70
4.6	Phased Development.....	72
5.	Project Development, Route Planning, and Site Selection.....	72
5.1	Project Screening and Siting .....	72
5.1.1	Interconnection Points .....	74
5.1.2	Onshore and Offshore Export Cable Route Corridors.....	76

5.1.3	Landfalls .....	81
5.1.4	Onshore Substations .....	82
5.1.5	Project Boundary .....	83
5.1.5.1	Project Boundary Options Considered .....	83
5.1.5.2	Project Boundary Carried Forward .....	88
5.1.6	Wind Farm Area .....	89
5.2	Design Alternatives Reviewed and Not Carried Forward .....	89
<b>6.</b>	<b>Project Infrastructure and Description of Activities .....</b>	<b>92</b>
6.1	Offshore Infrastructure and Activities .....	92
6.1.1	Project Components .....	92
6.1.1.1	Foundations .....	92
6.1.1.2	Turbines .....	94
6.1.1.3	Offshore Substations .....	97
6.1.1.4	Array Cables .....	102
6.1.1.5	Substation Interconnector Cables .....	105
6.1.1.6	Offshore Export Cables .....	106
6.1.2	Construction .....	109
6.1.2.1	Site Preparation Activities .....	109
6.1.2.2	Foundations .....	113
6.1.2.3	Scour Protection .....	115
6.1.2.4	Turbines .....	115
6.1.2.5	Offshore Substations .....	122
6.1.2.6	Array Cables .....	124
6.1.2.7	Substation Interconnection Cables .....	128
6.1.2.8	Offshore Export Cables .....	128
6.1.3	Construction and Operation Surveys .....	130
6.1.4	Operation and Maintenance .....	131
6.1.4.1	Turbine Foundation and Substation Foundation Maintenance Activities .....	131
6.1.4.2	Turbine Maintenance Activities .....	132
6.1.4.3	Offshore Substation Operation and Maintenance Activities .....	133
6.1.4.4	Cable Maintenance Activities .....	133
6.1.4.5	Operation and Maintenance Vessels .....	135
6.1.5	Non-routine Activities .....	136
6.1.5.1	Spare Parts .....	136

6.1.5.2	Workforce.....	136
6.1.5.3	Site Accessibility .....	136
6.2	Onshore Infrastructure and Activities .....	136
6.2.1	Project Components .....	137
6.2.1.1	Onshore Export Cable .....	137
6.2.1.2	Onshore Substations .....	143
6.2.1.3	Onshore Grid Connection .....	144
6.2.2	Construction .....	149
6.2.2.1	Cable Landfall .....	149
6.2.2.2	Onshore Substation .....	158
6.2.2.3	Onshore Export Cable Installation .....	158
6.2.2.4	Onshore Grid Connection .....	160
6.2.3	Operation and Maintenance .....	160
6.2.3.1	Onshore Operation and Maintenance Facilities .....	160
6.2.3.2	Onshore Operation and Maintenance Activities for Onshore Electrical Plants .....	161
6.2.4	Non-routine Activities.....	162
6.3	Decommissioning Plan .....	162
6.3.1	Offshore Decommissioning .....	162
6.3.2	Onshore Decommissioning .....	163
7.	<b>Health and Safety .....</b>	<b>163</b>
7.1	Introduction.....	163
7.2	Major Components of the Project SMS .....	164
7.2.1	Ocean Wind Organization .....	164
7.2.2	Communication Plan .....	164
7.2.3	Contractor Management.....	165
7.2.4	Risk Management Process.....	165
7.2.5	Competence, Training, and Awareness .....	165
7.2.6	Medical Clearance.....	165
7.2.7	Emergency Preparedness and Response.....	166
7.2.8	Incident Reporting and Investigation .....	166
7.2.9	SMS Evaluation and Monitoring .....	166
7.2.10	SMS Review .....	166
7.3	Cybersecurity.....	166
7.4	Obstruction Lighting and Markings.....	167



7.4.1	Obstruction Lighting.....	167
7.4.2	Markings.....	167
8.	Waste Management and Chemicals.....	168
8.1	Chemicals.....	168
8.2	Waste Management.....	170
8.2.1	Offshore Wastes.....	170
8.2.2	Onshore Wastes.....	171
9.	Other Information.....	171
9.1	Design Standards.....	171
10.	References.....	172

**List of Tables**

Table ES-1.	Summary of primary potential Project impacts.....	8
Table 1.3-1.	Commercial lease stipulations and compliance.....	26
Table 2.2-1.	Regulatory requirements for the Project.....	38
Table 2.3-1.	Consultation with stakeholders.....	46
Table 2.3-2.	Stakeholder engagement.....	58
Table 4.4-1.	Summary of PDE parameters.....	68
Table 5.1-1.	Summary of criteria for Project screening and siting.....	73
Table 5.2-1.	Design alternatives reviewed and not carried forward.....	90
Table 6.1.1-1.	Foundation options for offshore structures.....	93
Table 6.1.1-2.	Maximum design parameters for turbines.....	94
Table 6.1.1-3.	Maximum design parameters and impacts for turbine foundations.....	94
Table 6.1.1-4.	Maximum design parameters for topside offshore substations.....	100
Table 6.1.1-5.	Maximum design parameters and impacts for substation foundations.....	101
Table 6.1.1-6.	Maximum design parameters for piled jacket foundations for substations.....	102
Table 6.1.1-7.	Array cable design parameters and impacts.....	105
Table 6.1.1-8.	Substation interconnector cable parameters and impacts.....	106
Table 6.1.1-9.	Offshore export cable design parameters.....	107
Table 6.1.1-10.	Maximum total impacts for offshore export cables.....	107
Table 6.1.2-1.	Wind turbine vessel trips.....	122
Table 6.1.2-2.	Wind Turbine and Foundation Installation Vessel Details.....	122
Table 6.1.2-3.	Vessels required for substation installation.....	123
Table 6.1.2-4.	Number of installation days for cable sections inshore and offshore.....	124
Table 6.1.2-5.	Vessels required for array cable installation.....	128
Table 6.1.2-6.	Array cable installation vessel details.....	128
Table 6.1.2-7.	Vessels required for substation interconnection cable installation.....	128
Table 6.1.2-8.	Vessels required for offshore export cable installation.....	130
Table 6.1.2-9.	Offshore export cable installation vessel details.....	130
Table 6.1.4-1.	Total Project offshore surveys of foundations, bathymetry, scour protection and cable burial.....	131
Table 6.1.4-2.	Offshore foundation operation and maintenance activities.....	132

Table 6.1.4-3. Total WTG operation and maintenance activities. ....	133
Table 6.1.4-4. Total Project offshore substation operation and maintenance activities. ....	133
Table 6.1.4-5. Total Project offshore cable operation and maintenance activities. ....	134
Table 6.1.4-6. Offshore operation and maintenance vessel summary of maximum annual visits. ....	135
Table 6.1.4-7. Operations jack-up and anchored vessel parameters. ....	135
Table 6.2.1-1. Onshore export cable parameters. ....	137
Table 6.2.1-2. Onshore substation parameters. ....	143
Table 6.2.1-3. Underground and overhead transmission line parameters. ....	144
Table 6.2.2-1. Landfall parameters. ....	150
Table 8.1-1. Summary of maximum potential volumes oils, fuels, and lubricants per WTG. ....	169
Table 8.1-2. Summary of maximum volumes oils, fuels, and lubricants per offshore substation. ....	169
Table 8.1-3. Summary of maximum volumes oils, fuels, and lubricants per onshore substation. ....	169
Table 8.2-1. Anticipated solid and liquid wastes generated during offshore work. ....	170

**List of Figures**

Figure 1.1-1. Lease Area and Project boundaries. ....	25
Figure 4.1-1. Location plat and key Project components. ....	64
Figure 4.1-2. Indicative Location Plan. ....	65
Figure 4.2-1. Indicative key Project components. ....	67
Figure 4.5-1. Indicative schedule. ....	71
Figure 5.1-1. Project location - Oyster Creek. ....	77
Figure 5.1-2. Project location - Barnegat Bay/Oyster Creek. ....	78
Figure 5.1-3. Project location - BL England. ....	79
Figure 5.1-4. Project boundaries considered for the Project. ....	84
Figure 5.1-5. Indicative Location Plan - 1,500 m separation option. ....	87
Figure 6.1.1-1. A monopile with transition piece foundation with scour protection stone bed. ....	93
Figure 6.1.1-2. Maximum design scenario for wind turbines. ....	95
Figure 6.1.1-3. WTG exterior - indicative. ....	96
Figure 6.1.1-4. WTG interior - indicative. ....	96
Figure 6.1.1-5. Indicative monopile foundation offshore substation (London Array). ....	98
Figure 6.1.1-6. Indicative offshore substation with piled jacket foundation (Racebank). ....	98
Figure 6.1.1-7. Indicative offshore substation with helideck (Hornsea I). ....	99
Figure 6.1.1-8. Typical array, interconnector, and offshore export cable cross section. ....	103
Figure 6.1.1-9. Indicative burial for array, interconnector, and offshore export cable (depth could be less based on cable burial risk assessment). ....	104
Figure 6.1.2-1. Examples of displacement plow. ....	111
Figure 6.1.2-2. Example subsea grab. ....	112
Figure 6.1.2-3. Example pre-lay grapnel run string. ....	112
Figure 6.1.2-4. Upending of tower section in load-out port. ....	116
Figure 6.1.2-5. Towers assembled and ready at the load-out port. ....	117
Figure 6.1.2-6. Towers assembled and ready for load-out. ....	117
Figure 6.1.2-7. Nacelles pre-assembled and ready at load-out port. ....	118
Figure 6.1.2-8. Blades ready at load-out port. ....	118
Figure 6.1.2-9. Loading towers onto installation vessel. ....	119
Figure 6.1.2-10. Installation of a WTG blade. ....	120
Figure 6.1.2-11. DP2 vessel and CTV. ....	121

Figure 6.1.2-12. Installation of an offshore substation. ....	123
Figure 6.1.2-13. Subsea cable being spooled from factory/quayside turntable. ....	125
Figure 6.1.2-14. First-end pull. ....	125
Figure 6.1.2-15. Second-end pull. ....	126
Figure 6.2.1-1. Typical concrete-encased duct bank cross-section. ....	139
Figure 6.2.1-2. Typical direct-buried conduit cross-section. ....	140
Figure 6.2.1-3. Indicative HDD configuration (Oyster Creek). ....	141
Figure 6.2.1-4. Indicative onshore transmission cable splice vault. ....	142
Figure 6.2.1-5. Indicative overhead transmission line/underground cable route options – Oyster Creek. ....	146
Figure 6.2.1-6. Indicative underground transmission cable route – BL England. ....	147
Figure 6.2.1-7. Indicative onshore transmission structure for Oyster Creek. ....	148
Figure 6.2.2-1. Typical transitional HDD cross-section. ....	149
Figure 6.2.2-2. Example HDD rig in operation at entry point. ....	150
Figure 6.2.2-3. Indicative layout for HDD site. ....	152
Figure 6.2.2-4. Indicative landfall HDD cross section. ....	153
Figure 6.2.2-5. Indicative 275-kV TJB design. ....	155
Figure 6.2.2-6. Typical open cut landfall. ....	156
Figure 6.2.2-7. Indicative layout for open cut site. ....	157
Figure 6.2.3-1. Proposed location of O&M facility. ....	161

**Abbreviations and Acronyms**

AC	alternating current
ADCP	Acoustic Doppler Current Profiler
AIS	automatic identification systems
ALARP	as low as reasonably practicable
ANJEC	Association of New Jersey Environmental Commissions
APM	applicant proposed measures
AQRV	air quality related values
BOEM	Bureau of Ocean Energy Management
CAFRA	Coastal Area Review Facility Act
CFE	controlled flow excavation
CFR	Code of Federal Regulations
COP	Construction and Operations Plan
CTV	crew transfer vessel
CVA	Certified Verification Agent
DLRP	Division of Land Resource Protection
DLUR	Division of Land Use Regulation
DOD	Department of Defense
DP	dynamic positioning
ECR	export cable route
EMF	electromagnetic fields
EPAAct	Energy Policy Act of 2005
ERP	emergency response plan
ESA	endangered species act
FAA	Federal Aviation Administration
FDR/FIR	facility design report/fabrication and installation report
ft	feet
GCC	ground continuity conductor
GIS	geographical information system
GW	gigawatts
H&S	health & safety
HDD	horizontal directional drilling
HRG	high-resolution geophysical
HRG&G	high-resolution geophysical and geotechnical
HSE	health, safety, and environment
HV	high-voltage
HVAC	high-voltage alternating current
HVDC	high-voltage direct current
IALA	International Association of Marine Aids to Navigation and Lighthouse Authorities
IBSP	Island Beach State Park
IHA	incidental harassment authorization
IMO MARPOL	International Maritime Organization's International Convention for the Prevention of Pollution from Ships
IPF	impact producing factors
IPS	intermediate peripheral structure
IT	information technology

kJ	kilojoule
km	kilometer
kV	kilovolt
KVA	kilovolt-amp
lb	pound
m	meters
MAC	Mariners Advisory Committee
MEC	munitions and explosives of concern
MHW	mean high water
MHHW	mean higher high water
MLLW	mean lower low water
MOU	Memorandum of Understanding
MW	megawatts
N.J.A.C.	New Jersey Administrative Code
N.J.S.A.	New Jersey Statutes Annotated
NEPA	National Environmental Policy Act
NERC	North American Electric Reliability Corporation
NHPA	National Historic Preservation Act
NJBPU	New Jersey Board of Public Utilities
NJDEP	New Jersey Department of Environmental Protection
NJDOT	New Jersey Department of Transportation
NJHPO	New Jersey Historic Preservation Office
NJPDES	New Jersey Pollutant Discharge Elimination Program
nm	nautical miles
NMFS	National Marine Fisheries Service
NOAA	National Oceanic and Atmospheric Administration
NPCC	Northeast Power Coordination Council
O&M	operations and maintenance
Ocean Wind	Ocean Wind LLC
OCS	outer continental shelf
OCSLA	Outer Continental Shelf Lands Act
OCW01	Ocean Wind Offshore Wind Farm Project
OEM	original equipment manufacturer
OREC	Offshore Wind Renewable Energy Certificate
Orsted	Orsted Wind Power North America LLC
OWEDA	Offshore Wind Economic Development Act
PATON	private aid to navigation
PDE	Project Design Envelope
PJM	Pennsylvania, Jersey, Maryland
PSEG	Public Service Enterprise Group Renewable Generation LLC
PVC	polyvinyl chloride
QC	quality control
RAL	radar activated light
RARMS	Risk Mitigation Strategy
RODA	Responsible Offshore Development Alliance
ROV	remotely operated vehicle
ROW	right-of-way

RTO	regional transmission organization
SAP	Site Assessment Plan
SCADA	supervisory control and data acquisition
SES	Surface Effect Ship
SF6	Sulfur hexafluoride
SMS	Safety Management System
SOV	service operation vessel
SPS	significant peripheral structure
STATCOM	static synchronous compensator
STEM	science, technology, engineering, and math
SVC	static VAR compensator
TJB	transition joint bay
U.S.C	United States Code
USACE	U.S. Army Corps of Engineers
USCG	U.S. Coast Guard
USEPA	U.S. Environmental Protection Agency
USFWS	U.S. Fish and Wildlife Service
UXO	unexploded ordnance
VAR	volt amperes reactive
WTG	wind turbine generator

## 1. Project and Proponent Information Overview

### 1.1 Ocean Wind LLC

#### 1.1.1 About the Applicant

As noted above, Ocean Wind is an affiliate of Orsted. Orsted is the world leader in offshore wind development, construction, and operation. With the 2018 acquisition of Deepwater Wind, Orsted has added a local and regional track record of success in offshore wind on the U.S. East Coast that is unmatched. With the joint venture agreement between Orsted and Public Service Enterprise Group Renewable Generation LLC (PSEG), Ocean Wind has added regional onshore energy expertise to the Project.

Orsted's "develop, build, own, and operate model" means the company is vested in the long-term success of its wind farms. Orsted's track record demonstrates that it is careful not to overpromise and upholds its commitments. Orsted remains responsible for delivering on its obligations over the life of the asset. Orsted's financial success is inextricably linked to the performance of generation assets over the useful life of the projects. This means that Orsted's interests are well-aligned with those of the ratepayers Orsted serves.

Orsted's leadership in global offshore wind development is unparalleled with nearly three times the installed capacity of its closest competitors. Over the past 25 years, Orsted has constructed 5,100 MW (5.1 gigawatts (GW)) of offshore wind capacity, with another 3.8 GW under construction, taking its operation base to 9 GW of capacity. The lessons learned over this 25+ year evolution culminate in this Project, reflecting the very best in offshore wind design, engineering, finance and construction, and adapting these best practices to the U.S. East Coast market. All of Orsted's experience in offshore wind in development, construction, operation, and decommissioning is relevant to the Project. Specific examples of Orsted's expertise in development and operations of offshore wind energy projects include:

- Designed and constructed the largest wind farm in operation today (Walney Extension, 2018);
- Competitively awarded a power purchase agreement for what will be the largest wind farms in the world once constructed (Hornsea I and II's combined 2,600 MW);
- Permitted complex projects with input and permitting and authorizations required from numerous stakeholders, including regulatory agencies, non-governmental organizations, and the fishing industry;
- Designed and planned high-voltage transmission solutions capable of delivering power from offshore wind projects to identified onshore grid connection points, from as far away as 50 miles (Walney Extension, Race Bank, and Hornsea I);
- Constructed offshore wind farms in challenging marine environments, including projects that are far from shore, and in environments having high wave heights, high wind speeds, and rough sea conditions; and
- Planned and executed O&M strategies for offshore wind farms.

Orsted's experience gained from the development, construction, and operation of multiple offshore projects in Europe enables the design and implementation of technical solutions that are appropriate and proven. Orsted has unparalleled experience in securing financing, operating, and maintaining offshore wind projects. Orsted's deep understanding of life-cycle cost and risk gained from almost three decades of offshore wind experience allows the company to capture first-mover advantage on key technology.

### 1.1.2 Contact Information

Name of Lease Representative: Peter Allen  
Title: Head of Finance  
Phone Number: 857-354-1002  
Email: PEALL@orsted.com  
Address: 399 Boylston St., 12<sup>th</sup> Floor, Boston, MA 02116

### 1.1.3 Designation of Operator

Ocean Wind will be the operator of the Project.

### 1.1.4 Financial Assurance

In accordance with 30 CFR § 585, Subpart E, Ocean Wind will provide financial assurance to BOEM for both COP approval and authorization to install approved facilities pursuant to the COP.

### 1.1.5 Certified Verification Agent Nomination

Pursuant to 30 CFR § 585.705, a Certified Verification Agent (CVA) must be used to certify to BOEM that the proposed facility is designed to withstand the environmental and functional load conditions for the intended life of the Project at its proposed location. The CVA will also review the relevant design standards and environmental loading for the structural design of the facilities.

#### **Nomination Statement**

In accordance with 30 Code of Federal Regulations (CFR) § 585.706, Ocean Wind nomination for its CVA is set forth in Appendix C.

#### **Qualification Statement**

The Statement of Qualification for the CVA Services is provided in Appendix C. The Statement addresses:

- Previous experience of the nominated CVA in third-party verification and BOEM procedures;
- Technical capabilities of the CVA and staff members;
- Size and type of organization;
- Availability of technology;
- Ability to perform;
- Conflict of interest; and
- Professional Engineer supervision.

#### **Scope of Work**

The CVA Scope of Work is also provided in Appendix C. This document specifies the level of work to be performed by the CVA at all phases of the Project and identifies the documents and subject matter that the CVA will review.

## **1.2 Introduction**

Ocean Wind is developing the proposed Project to generate renewable power off the coast of New Jersey and transfer the electricity to load centers within New Jersey and the Mid-Atlantic region. Under the New Jersey Offshore Wind Economic Development Act (OWEDA), the New Jersey Board of Public Utilities (NJBPU) is required to establish an Offshore Wind Renewable Energy Certificate (OREC) program requiring a percentage of electricity sold in the state be from derived from offshore wind energy, in order to support at least 1,100 MW of generation from qualified projects. On June 21, 2019, the NJBPU selected Ocean Wind to develop the



Ocean Wind Project proposed in this COP. The Project is being developed pursuant to the BOEM requirements for the Ocean Wind BOEM Lease Area OCS-A 0498 Commercial Lease of Submerged Lands for Renewable Energy Development on the Outer Continental Shelf (Lease) (30 CFR Part 585 and regulations therein). The Project will include offshore wind turbines for power generation and associated infrastructure required to transmit electricity generated by the turbines to onshore interconnection points with the regional electric transmission system operated by PJM Interconnection L.L.C. (PJM).

The Lease Area is approximately 75,525 acres and is located approximately 13 nm southeast of Atlantic City (**Figure 1.1-1**). The Project is expected to deliver first power in late 2024 or early 2025.

On December 4, 2020, Orsted announced that it had entered into an agreement to sell a 25 percent ownership interest in the Ocean Wind Project to New Jersey's Public Service Enterprise Group (PSEG). In March 2021, the New Jersey Board of Public Utilities approved the sale by Orsted to PSEG. The joint ownership structure utilizes the respective capabilities and experience of the parties.

Reinforcement and upgrades to the PJM electrical transmission system may be required, subject to the completion of required PJM system studies and final Project interconnection capacity. Historically the power grid in New Jersey was built up to supply the main load centers from large conventional fuel generation, such as coal, oil, gas and nuclear, as well as interconnection with the rest of the state and neighboring states. Two large generators of this type have recently retired on the Atlantic Coast, which were connected to the grid near the Ocean Wind Offshore Wind Farm. These are the Oyster Creek nuclear (636 MW) and the BL England coal, oil, and diesel (450 MW) generators. The power output of these plants was less than the planned capacity of the Ocean Wind Offshore Wind Farm. Also, the grid which connects these plants was originally designed around the power station output and not a substantial amount more. Therefore, injecting the Project power into one location on the onshore grid would require the onshore system to be upgraded accordingly. This may require the grid operator to strengthen the system and potentially build new power lines. In order to reduce the environmental impact and, at the same time provide the most economical solution to the New Jersey rate payers, Ocean Wind is looking to best utilize the available points of interconnection to the onshore grid. Rather than injecting the Project power at Oyster Creek alone, a potential solution is to split the power injection to two different interconnection points with the onshore grid, in amounts similar to the ratings of the old conventional plants, which have now retired. This could reduce the impact of the Project on the existing onshore power grid.

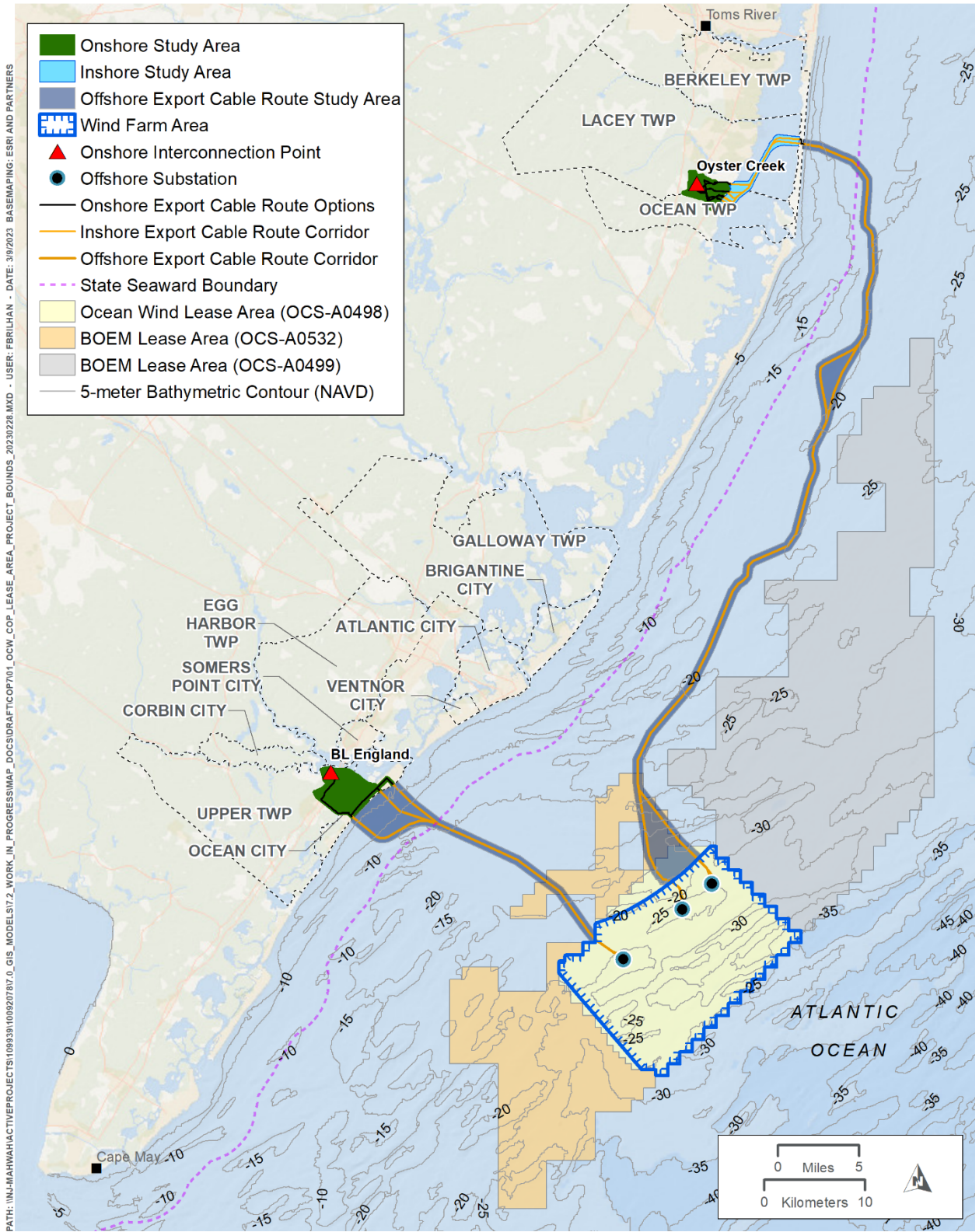

**Figure 1.1-1. Lease Area and Project boundaries**

### 1.3 Commercial Lease Stipulations and Compliance

A description of the measures Ocean Wind will take to satisfy the conditions of the lease stipulations related to the proposed Project activities are summarized in **Table 1.3-1**.

**Table 1.3-1. Commercial lease stipulations and compliance.**

Lease Requirements	Description	Compliance Statement/Location within COP
Section 4: Payments (a)	The lessee must make all rent payments to the Lessor in accordance with applicable regulations in 30 CFR Part 585, unless otherwise specified in Addendum "B".	Ocean Wind has made and will continue to make all rent payments according to the applicable regulations, unless otherwise specified in Addendum "B".
Section 4: Payments (b)	The Lessee must make all operating fee payments to the Lessor in accordance with applicable regulations in 30 CFR Part 585, as specified in Addendum "B".	Ocean Wind will make all operating fee payments in accordance with applicable regulations.
Section 5	The Lessee may conduct those activities described in Addendum "A" only in accordance with a Site Assessment Plan (SAP) or COP approved by the Lessor. The Lessee may not deviate from an approved SAP or COP except as provided in applicable regulations in 30 CFR Part 585.	Ocean Wind will conduct all its activities as described in the SAP and COP, unless a deviation is approved in accordance with 30 CFR Part 585.
Section 6: Associated Project Easements	Pursuant to 30 CFR 585.200(b), the Lessee has the right to one or more project easements, without further competition, for the purpose of installing gathering, transmission, and distribution cables, pipelines, and appurtenances on the outer continental shelf (OCS), as necessary for the full enjoyment of the lease, and under applicable regulations in 30 CFR Part 585. As part of submitting a COP for approval, the Lessee may request that one or more easement(s) be granted by the Lessor. If the Lessee requests that one or more easement(s) be granted when submitting a COP for approval, such project easements will be granted by the Lessor in accordance with the Act and applicable regulations in 30 CFR Part 585 upon approval of the COP in which the Lessee has demonstrated a need for such easements. Such easements must be in a location acceptable to the Lessor and will be subject to such conditions as the Lessor may require. The project easement(s) that would be issued in conjunction with an approved COP under this lease will be described in Addendum "D" to this lease, which will be updated as necessary.	With the approval of this COP, Ocean Wind requests that BOEM issue a project easement for the portions of the Project located in federal waters under the applicable regulations in 30 CFR Part 585.
Section 7: Conduct of Activities	The Lessee must conduct, and agrees to conduct, all activities in the leased area in accordance with an approved SAP or COP, and with all applicable laws and regulations.	Ocean Wind will conduct all activities in the leased area in accordance with the SAP and COP and all applicable laws and regulations.
Section 10: Financial Assurance	The Lessee must provide and maintain at all times a surety bond(s) or other form(s) of financial assurance approved by the Lessor in the amount specified in Addendum "B".	Ocean Wind will provide the necessary financial assurances as described in the Lease and in Section 1.1.4 of Volume I of the COP.

Lease Requirements	Description	Compliance Statement/Location within COP
Section 13: Removal of Property and Restoration of the Leased Area on Termination of Lease.	Unless otherwise authorized by the Lessor, pursuant to the applicable regulations in 30 CFR Part 585, the Lessee must remove or decommission all facilities, projects, cables, pipelines, and obstructions and clear the seafloor of all obstructions created by activities on the leased area, including any project easements within two years following lease termination, whether by expiration, cancellation, contraction, or relinquishment, in accordance with any approved SAP, COP, or approved Decommissioning Application, and applicable regulations in 30 CFR Part 585.	Section 6.3 of Volume I of the COP describes the preliminary decommissioning plans.  The decommissioning efforts will proceed according to all applicable regulations.
Section 14: Safety Requirements	The Lessee must: (a) Maintain all places of employment for activities authorized under this lease in compliance with occupational safety and health standards and, in addition, free from recognized hazards to employees of the Lessee or of any contractor or subcontractor operating under this lease; (b) Maintain all operations within the leased areas in compliance with regulations in 30 CFR Part 585 and orders from the Lessor and other Federal agencies with jurisdiction, intended to protect persons, property and the environment on the OCS; and (c) Provide any requested documents and records, which are pertinent to occupational or public health, safety, or environmental protection, and allow prompt access, at the site of any operation or activity conducted under this lease, to any inspector authorized by the Lessor or other Federal agency with jurisdiction.	(a) Ocean Wind will maintain all places of employment in compliance with applicable standards. (b) Ocean Wind will maintain all operations in the leased area in compliance with applicable regulations. (c) Ocean Wind will provide any requested documents and records and will allow Project access to authorized inspectors.  See also Section 7 in Volume I, plus Appendix B (Safety Management Plan), Appendix C (CVA Services), Appendix D Marine Site Investigation Report, Appendix M (Navigation Safety Risk Assessment), and Appendix U (Conceptual Plans and Typical Design Drawings).
Section 15: Debarment Compliance	The Lessee must comply with the Department of the Interior's non-procurement debarment and suspension regulations set forth in 2 CFR Parts 180 and 1400 and must communicate the requirement to comply with these regulations to persons with whom it does business related to this lease by including this requirement in all relevant contracts and transactions.	Ocean Wind will comply with the applicable debarment and suspension regulations.
Section 16: Equal Opportunity Clause	During the performance of this lease, the Lessee must fully comply with paragraphs (1) through (7) of section 202 of Executive Order 11246, as amended (reprinted in 41 CFR 60-1.4(a)), and the implementing regulations, which are for the purpose of preventing employment discrimination against persons on the basis of race, color, religion, sex, or national origin. Paragraphs (1) through (7) of section 202 of Executive Order 11246, as amended, are incorporated in this lease by reference.	Ocean Wind will fully comply with paragraphs (1) through (7) of section 202 of Executive Order 11246, as amended.
Addendum "B", Section III (Payments)	Unless otherwise authorized by the Lessor in accordance with the applicable regulations in 30 CFR Part 585, the Lessee must make payments as described below.	Ocean Wind will make payments as stipulated in Addendum "B", Section III.

## **2. Regulatory Framework and Stakeholder Outreach**

### **2.1 Required Information in COP**

As required by 30 CFR Part 585, this COP for OCS renewable energy activities on a commercial lease has been prepared to demonstrate that the Project is being conducted in a manner that conforms to the requirements for responsible offshore development established in 30 CFR 585.621. Specifically, this COP demonstrates that the development, operation, and decommissioning of the Project: will conform to applicable laws, implementing regulations, Lease provisions, and stipulations or conditions of the Lease; will not unreasonably interfere with other uses of the OCS; will not cause undue harm or damage to natural resources, life (including human and wildlife), property, the marine, coastal, or human environment, or sites, structures, or objects of historical or archaeological significance; will take measures to prevent the unauthorized discharge of pollutants including marine trash and debris into the offshore environment; will use best available and safe technology; will use best management practices; will use properly trained personnel; and will be safe.

This COP describes the construction, operations, and conceptual decommissioning plans for the Project, including planned construction of onshore and offshore support facilities and anticipated Project easements. Information required in a COP is specified in 30 CFR 585.626 and 627 and is intended to assist BOEM in complying with National Environmental Policy Act (NEPA) obligations and other relevant laws.

#### **2.1.1 Location of Required Information in COP**

Information	Requirements	Location(s)
<b>§585.626(a) You must submit the following surveys including:</b>		
(1) Shallow Hazards: The results of the shallow hazards survey with supporting data	Information sufficient to determine the presence of the following features and their likely effects on your proposed facility, including:	Vol. III, Appendix D, Marine Site Investigation Report
	(i) Shallow faults;	
	(ii) Gas seeps or shallow gas;	
	(iii) Slump blocks or slump sediments;	
	(iv) Hydrates; or	
(v) Ice scour of seabed sediments.		
(2) Geological survey relevant to the design and siting of your facility: The results of the geological survey with supporting data	Assessment of:	Vol. III, Appendix D, Marine Site Investigation Report
	(i) Seismic activity at your proposed site;	
	(ii) Fault zones;	
	(iii) The possibility and effects of seabed subsidence; and	
(iv) The extent and geometry of faulting attenuation effects of geologic conditions near your site.		
(3) Biological: The results of the biological survey with supporting data	A description of the results of biological surveys used to determine the presence of live bottoms, hard bottoms, and topographic features, and surveys of other marine resources such as fish populations (including migratory populations), marine mammals, sea turtles, and sea birds.	Vol. II, Section 2.2 Vol. III, Appendix E, Biological Survey Results
(4) Geotechnical survey: The results of your sediment testing program with supporting data, the various field and laboratory test methods employed, and the applicability of these methods as they pertain to the quality of the samples, the type of sediment, and the anticipated design application. You must explain how the engineering properties of each sediment stratum affect the design of your	(i) The results of a testing program used to investigate the stratigraphic and engineering properties of the sediment that may affect the foundations or anchoring systems for your facility.	Vol. III, Appendix D, Marine Site Investigation Report
	(ii) The results of adequate <i>in situ</i> testing, boring, and sampling at each foundation location, to examine all important sediment and rock strata to determine its strength classification, deformation properties, and dynamic characteristics.	

Information	Requirements	Location(s)
facility. In your explanation, you must describe the uncertainties inherent in your overall testing program, and the reliability and applicability of each test method	(iii) The results of a minimum of one deep boring (with soil sampling and testing) at each edge of the project area and within the project area as needed to determine the vertical and lateral variation in seabed conditions and to provide the relevant geotechnical data required for design.	
(5) Archaeological resources: The results of the archaeological resource survey with supporting data	A description of the historic and prehistoric archaeological resources, as required by the NHPA (16 U.S.C. 470 et. seq.), as amended.	Vol. II, Section 2.4 Vol. III, Appendix F, Archaeology Survey Report
(6) Overall site investigation: An overall site investigation report for your facility that integrates the findings of your shallow hazards surveys and geologic surveys, and, if required, your subsurface surveys with supporting data	An analysis of the potential for:	Vol. III, Appendix D, Marine Site Investigation Report
	(i) Scouring of the seabed	
	(ii) Hydraulic instability	
	(iii) The occurrence of sand waves	
	(iv) Instability of slopes at the facility location	
	(v) Liquefaction, or possible reduction of sediment strength due to increased pore pressures	
	(vi) Degradation of subsea permafrost layers	
	(vii) Cyclic loading	
	(viii) Lateral loading	
	(ix) Dynamic loading	
	(x) Settlements and displacements	
	(xi) Plastic deformation and formation collapse mechanisms	
(xii) Sediment reactions on the facility foundations or anchoring systems		
<b>§585.626(b) Requirements</b>		
(1) Contact information	The name, address, e-mail address, and phone number of an authorized representative.	Vol. I, Section 1.2.2
(2) Designation of operator, if applicable	As provided in § 585.405	Vol. I, Section 1.1.3

Information	Requirements	Location(s)
(3) The construction and operation concept	A discussion of the objectives, description of the proposed activities, tentative schedule from start to completion, and plans for phased development, as provided in § 585.629	Vol. I, Sections 1, 4, 5, and 6
(4) Commercial lease stipulations and compliance	A description of the measures you took, or will take, to satisfy the conditions of any lease stipulations related to your proposed activities.	Vol. I, Section 1.3
(5) A location plat	The surface location and water depth for all proposed and existing structures, facilities, and appurtenances located both offshore and onshore, including all anchor/mooring data.	Vol. I, Section 4.1.2 Vol. III, Appendix G, Location of Offshore Turbines and Substations
(6) General structural and project design, fabrication, and installation	Information for each type of structure associated with your project and, unless BOEM provides otherwise, how you will use a CVA to review and verify each stage of the project.	Vol. I, Sections 1.2, 4, 6, and 9 Vol. III, Appendix C, Certified Verification Agent Services Vol. III, Appendix U, Conceptual Plans and Typical Design Drawings
(7) All cables and pipelines, including cables on project easements	Location, design and installation methods, testing, maintenance, repair, safety devices, exterior corrosion protection, inspections, and decommissioning.	Vol. I, Sections 4 and 6
(8) A description of the deployment activities	Safety, prevention, and environmental protection features or measures that you will use.	Vol. I, Sections 6 Vol. III, Appendix A, Emergency Response Plan Including Oil Spill Response Plan Vol. III, Appendix B, Safety Management System
(9) A list of solid and liquid wastes generated	Disposal methods and locations.	Vol. I, Section 8.2
(10) A listing of chemical products used (if stored volume exceeds Environmental Protection Agency (USEPA) Reportable Quantities)	A list of chemical products used; the volume stored on location; their treatment, discharge, or disposal methods used; and the name and location of the onshore waste receiving, treatment, and/or disposal facility. A description of how these products would be brought onsite, the number of transfers that may take place, and the quantity that that will be transferred each time.	Vol. I, Section 8.1



Information	Requirements	Location(s)
(11) A description of any vessels, vehicles, and aircraft you will use to support your activities	An estimate of the frequency and duration of vessel/vehicle/aircraft traffic.	Vol. I, Section 6
(12) A general description of the operating procedures and systems	(i) Under normal conditions.	Vol. I, Sections 6.1.3, 6.1.4, 6.2.3 and 6.2.4 Vol. III, Appendix B, Safety Management System
	(ii) In the case of accidents or emergencies, including those that are natural or manmade.	Vol. III, Appendix A, Emergency Response Plan
(13) Decommissioning and site clearance procedures	A discussion of general concepts and methodologies.	Vol. I, Section 6.3
(14) A listing of all Federal, State, and local authorizations, approvals, or permits that are required to conduct the proposed activities, including commercial operations	(i) The U.S. Coast Guard, U.S. Army Corps of Engineers, and any other applicable authorizations, approvals, or permits, including any Federal, State or local authorizations pertaining to energy gathering, transmission or distribution (e.g., interconnection authorizations).	Vol. I, Section 2.2
	(ii) A statement indicating whether you have applied for or obtained such authorization, approval, or permit.	
(15) Your proposed measures for avoiding, minimizing, reducing, eliminating, and monitoring environmental impacts	A description of the measures you will use to avoid or minimize adverse effects and any potential incidental take before you conduct activities on your lease, and how you will mitigate environmental impacts from your proposed activities, including a description of the measures you will use as required by subpart H of this part.	Vol. II, Sections 1 and 2
(16) Information you incorporate by reference	A listing of the documents you referenced.	Vol. I, Section 10 Vol. II, Section 3 Vol. III

Information	Requirements	Location(s)
(17) A list of agencies and persons with whom you have communicated, or with whom you will communicate, regarding potential impacts associated with your proposed activities	Contact information and issues discussed.	Vol. I, Sections 2.2 and 2.3
(18) Reference	A list of any document or published source that you cite as part of your plan. You may reference information and data discussed in other plans you previously submitted or that are otherwise readily available to BOEM.	Vol. I, Section 10 Vol. II, Section 3 Vol. III
(19) Financial assurance	Statements attesting that the activities and facilities proposed in your COP are or will be covered by an appropriate bond or security, as required by §§ 585.515 and 585.516.	Vol. I, Section 1.1.4
(20) CVA nominations for reports required in subpart G of this part	CVA nominations for reports in subpart G of this part, as required by § 585.706, or a request for a waiver under § 585.705(c).	Vol. I, Section 1.1.5 Vol. III, Appendix C, Certified Verification Agent Services
(21) Construction schedule	A reasonable schedule of construction activity showing significant milestones leading to the commencement of commercial operations.	Vol. I, Section 4.5
(22) Air quality information	As described in § 585.659 of this section.	Vol. II, Section 2.1.3 Vol. III, Appendix N, Air Quality Analysis
(23) Other information	Additional information as required by BOEM.	Vol. I – III
<b>§585.627(a) Requirements</b>		
<b>Information and Certifications for NEPA and other relevant laws</b>		<b>Location(s)</b>
(1) Hazard information	Meteorology, oceanography, sediment transport, geology, and shallow geological or manmade hazards.	Vol. III, Appendix D, Marine Site Investigation Report Appendix X, MEC and UXO Supplemental Information
(2) Water quality	Turbidity and total suspended solids from construction.	Vol. II, Section 2.1.2
(3) Biological resources	i) Benthic communities	Vol. II, Section 2.2.5 Appendix P, Technical Information to Support the EFH Consultation

Information	Requirements	Location(s)
	ii) Marine mammals	Vol. II, Section 2.2.7 Appendix E, Biological Survey Results Appendix J, Marine Mammal Supplementary Material R-2 Underwater Noise Supplementary Material Protected Species Mitigation and Monitoring Plan (PSMMP)
	iii) Sea turtles	Vol. II, Section 2.2.8 Appendix K, Sea Turtle Supplementary Material R-2 Underwater Noise Supplementary Material Appendix AA, PSMMP
	iv) Coastal and marine birds	Vol. II, Section 2.2.3 Appendix H, Assessment of the Potential Effects of the Ocean Wind Offshore Wind Farm on Birds & Bats Appendix AB, Avian and Bat Post-Construction Monitoring Framework
	v) Fish and shellfish	Vol. II, Section 2.2.6 Appendix I, Atlantic Sturgeon Supplementary Material Appendix P, Technical Information to Support the EFH Consultation R-2 Underwater Noise Supplementary Material Appendix AA, PSMMP
	vi) Plankton	Vol. II, Section 2.1.2.1.2, 2.2.6.1.4 Appendix P, Technical Information to Support the EFH Consultation
	vii) Sea grasses	Vol. II, Section 2.2.5.1.2 Appendix P, Technical Information to Support the EFH Consultation
	viii) Other plant life	Vol. II, Section 2.2.1

Information	Requirements	Location(s)
(4) Threatened or endangered species	As defined by the Endangered Species Act (ESA) of 1973 (16 U.S.C. 1531 <i>et seq.</i> ).	Vol. II, Section 2.2, Vol. III, Appendices H – K, AA, AB
(5) Sensitive biological resources or habitats	Essential fish habitat, refuges, preserves, special management areas identified in coastal management programs, sanctuaries, rookeries, hard bottom habitat, chemosynthetic communities, calving grounds, barrier islands, beaches, dunes, and wetlands.	Vol. II, Section 2.2, Vol. III, Appendices H – K, P, Q, AC
(6) Archaeological resources	As required by the NHPA (16 U.S.C. 470 <i>et seq.</i> ), as amended.	Vol. II, Section 2.4 Vol. III, Appendix F, Archaeology and Historic Properties Survey Report
(7) Social and economic conditions	Employment, existing offshore and coastal infrastructure (including major sources of supplies, services, energy, and water), land use, subsistence resources and harvest practices, recreation, recreational and commercial fishing (including typical fishing seasons, location, and type), minority and lower income groups, coastal zone management programs, and viewshed.	Vol. II, Section 2.3 Vol. III, Appendix L, Visual Impact Assessment Appendix M, Navigation Safety Risk Assessment Appendix O, Fisheries Communication and Outreach Plan Appendix R, Noise Supplementary Material Appendix V, Env. Justice Supplementary Material Appendix AE, Fisheries Mitigation Efforts
(8) Coastal and marine resources	Military activities, vessel traffic, and energy and nonenergy mineral exploration or development	Vol. II, Sections 2.3.3, through 2.3.7 Vol. III, Appendix M, Navigation Safety Risk Assessment Appendix AD, Airspace and Radar Analysis
(9) Consistency Certification	As required by CZMA regulations: (i) 15 CFR part 930, subpart D, if the COP is submitted prior to lease issuance; (ii) 15 CFR part 930, subpart E, if the COP is submitted after lease issuance.	Volume II, Section 2.3.5 Vol. III, Appendix Q, Coastal Zone Consistency Assessment
(10) Other resources, conditions, and activities	As identified by BOEM.	Vol. I-III

Information	Requirements	Location(s)
<b>§585.627(b) Requirements</b>		
(1) One copy of your consistency certification under either subsection 307(c)(3)(B) of the CZMA (16 U.S.C. 1456(c)(3)(B)) and 15 CFR 930.76 or subsection 307(c)(3)(A) of the CZMA (16 U.S.C. 1456(c)(3)(A)) and 15 CFR 930.57, stating that the proposed activities described in detail in your plans comply with the State(s) approved coastal management program(s) and will be conducted in a manner that is consistent with such program(s)	Requirements listed in column to the left.	Volume III, Appendix Q, Coastal Zone Consistency Assessment
(2) "Necessary data and information,"	Required by 15 CFR 930.58.	Volume III, Appendix Q, Coastal Zone Consistency Assessment
<b>§585.627(c) Requirements</b>		
Information	Requirements	Location(s)
Oil Spill Response Plan	Required by 30 CFR part 254	Vol. III, Appendix A, Emergency Response Plan, Including Oil Spill Response Plan
<b>§585.627(d) Requirements</b>		
Information	Requirements	Location(s)
Safety Management System	Required by § 585.810	Vol. III, Appendix B, Safety Management System

### 2.1.2 Departure Requests

Pursuant to 30 CFR 585.103, BOEM may prescribe or approve departures from information required in a COP when necessary to: (1) facilitate the appropriate activities on a lease or grant under this part; (2) conserve natural resources; (3) protect life (including human and wildlife), property, or the marine, coastal, or human environment; or (4) protect sites, structures, or objects of historical or archaeological significance. Ocean Wind previously requested departures in Appendix T, but departures are no longer being requested.

## 2.2 Permits and Authorizations

Regulatory authority over renewable energy activities on the OCS is established from amendments to subsection 8 of the OCSLA (43 United States Code [U.S.C.] 1337), as set forth in section 388(a) of the Energy Policy Act of 2005 (EPAAct) (Pub. L. 109-58). The Secretary of the Interior delegated to BOEM the authority to regulate activities under section 388(a) of the EPAAct. BOEM has published regulations found in 30 CFR Part 585 to establish procedures for the issuance and administration of leases, ROW grants, and right-of-use and easement grants for renewable energy production on the OCS.

The Project components are proposed in Federal and New Jersey State waters, and onshore locations within the State of New Jersey. Within New Jersey State waters, the NJDEP is the lead permitting agency.

### 2.2.1 Regulatory Framework

**Table 2.2-1** below lists the anticipated Federal, State, and local authorizations that will be required for the Project. Ocean Wind has been coordinating with the Federal, State, and local authorities and will file appropriate permit applications based on the regulated activities of the Project. In addition, Ocean Wind was accepted as a “covered project” under FAST-41 (42 U.S.C. § 4370m) on October 15, 2019.<sup>3</sup>

As noted, under the New Jersey OWEDA, the NJBPU is required to establish an OREC program requiring a percentage of electricity sold in the state be from derived from offshore wind energy, in order to support at least 1,100 MW of generation from qualified projects. On June 21, 2019, the NJBPU selected Ocean Wind to develop the Project proposed in this COP.

---

<sup>3</sup> The Fixing America's Surface Transportation Act was enacted on December 4, 2015. Title 41 of that act (FAST-41) established new coordination and oversight procedures for infrastructure projects being reviewed by federal agencies. FAST-41 is intended to: improve early consultation and coordination among government agencies, increase transparency through the publication of project-specific timetables with completion dates for all federal authorizations and environmental reviews, and increase accountability through consultation and reporting on projects.

**Table 2.2-1. Regulatory requirements for the Project.**

Agency	Applicable Permit or Approval	Statutory Basis	Regulation	Anticipated Application Submittal Date or Consultation Status
<b>Federal</b>				
BOEM	Construction and Operations Plan (COP) Approval	Energy Policy Act of 2005	30 CFR Part 585 - Renewable Energy and Alternate Uses of Existing Facilities on the Outer Continental Shelf (contents of COP - 30 CFR §585.626 and §585.627) 43 CFR Part 46 - Department of Interior NEPA regulations	BOEM issued document
		NEPA, 42 U.S.C. §§ 4321 <i>et seq.</i>		
New Jersey Historic Preservation Office (NJHPO), Tribes	National Historic Preservation Act (NHPA) Section 106 Consultation (completed by BOEM as part of the COP review and approval process)	NHPA, 54 U.S.C. § 300101	36 CFR Part 60 - National Register of Historic Places	In conjunction with BOEM COP review
		(New Jersey Register of Historic Places Act N.J.S.A 13:1B)	36 CFR Part 800 - Protection of Historic Properties	In conjunction with BOEM COP review
National Oceanic and Atmospheric Administration (NOAA), National Marine Fisheries Service (NMFS)	Endangered Species Act (ESA) Section 7 Consultation (completed by BOEM as part of the COP review and approval process)	ESA 16 U.S.C. §§ 1531-1544	50 CFR Part 17 and Part 402	In conjunction with BOEM COP review. Consultation was completed April 3, 2023.
NMFS	Magnuson-Stevens Fishery Conservation and Management Act Consultation (completed by BOEM as part of the COP review and approval process)	Magnuson-Stevens Fishery Conservation and Management Act, 16 U.S.C. 1801	50 CFR Part 600	NMFS's EFH conservation recommendations letter was issued February 24, 2023.

Agency	Applicable Permit or Approval	Statutory Basis	Regulation	Anticipated Application Submittal Date or Consultation Status
NMFS	Incidental Take Regulation (ITR)/ Letter of Authorization (LOA)	Marine Mammal Protection Act, 16 U.S.C. 1361 <i>et seq.</i>	50 CFR Part 216	Submitted October 1, 2021 Deemed complete for review February 11, 2022. Proposed Rule issue for public review and comment October 26, 2022.
U.S. Fish and Wildlife Service (USFWS)	ESA Section 7 Consultation (completed by BOEM as part of the COP review and approval process)	ESA, 16 U.S.C. §§ 1531-1544	50 CFR Part 17 and Part 402	In conjunction with BOEM COP review
U.S. Environmental Protection Agency (USEPA) <sup>[1]</sup>	Air Permit for OCS Sources	Clean Air Act Section 328	40 CFR §55.6.	Submitted March 29, 2022; updates submitted on July 18, 2022 and October 7, 2022
U.S. Army Corps of Engineers (USACE)	Individual and Nationwide Permits	Sections 10 and 408 of Rivers and Harbors Act (33 U.S.C. 403 and 408); Section 404 of Clean Water Act (33 U.S.C. 1344)	33 CFR Parts 320 through 332.	Sections 10, 404, and 408 application submitted on April 27, 2022; update submitted January 27, 2023
Federal Aviation Administration (FAA)	FAA Form 7460-1, Notice of Proposed Construction or Alteration (for Hazard to Air Navigation Determination)	49 U.S.C. §1301 <i>et seq.</i>	14 CFR Part 77.	Submittal anticipated Q3 2023
U.S. Coast Guard (USCG)	Private Aid to Navigation (PATON) authorization	Ports and Waterways Safety Act, 33 U.S.C. 1221 <i>et seq.</i>	33 CFR §66.	Submittal anticipated Q3 2023
USCG	Local Notice to Mariners	Ports and Waterways Safety Act, 33 U.S.C. 1221 <i>et seq.</i>	33 CFR §72.01-5	Complete February 7, 2019



Agency	Applicable Permit or Approval	Statutory Basis	Regulation	Anticipated Application Submittal Date or Consultation Status
<b>New Jersey - State Permits/Authorizations</b>				
NJDEP, Division of Land Resource Protection (DLRP)	Individual Waterfront Development Permit and Coastal Consistency Determination	Waterfront Development Act New Jersey Statutes Annotated (N.J.S.A.) 12:5-3; Coastal Zone Management Act 16 U.S.C. §1456	Coastal Zone Management Rules New Jersey Administrative Codes (N.J.A.C.) 7:N.J.A.C. 7:7	Submitted August 3, 2022; Resubmitted January 13, 2023
NJDEP, DLRP	Individual Coastal Areas Facility Review Act Permit and Coastal Consistency Determination	Coastal Areas Facility Review Act, N.J.S.A. 13:19;	Coastal Zone Management Rules N.J.A.C. 7:7	Submitted August 3, 2022; Update submitted January 13, 2023
		Coastal Zone Management Act 16 U.S.C. §1456		
NJDEP, DLRP	Individual Coastal Wetlands Permit	Wetlands Act of 1970, N.J.S.A. 13:9A	Coastal Zone Management Rules N.J.A.C. 7:7	Submitted August 3, 2022; Resubmitted January 13, 2023
NJDEP, DLRP	Individual Flood Hazard Area Permit (obtained as part of Coastal Area Review Facility Act [CAFRA]/Waterfront Development permit)	Flood Hazard Area Control Act N.J.S.A. 58:16A	Flood Hazard Area Control Act Rules N.J.A.C. 7:13	Submitted August 3, 2022
NJDEP, DLRP	Individual Freshwater Wetlands Permit	Freshwater Wetlands Protection Act N.J.S.A. 13:9B	Freshwater Wetlands Protection Act Rules N.J.A.C. 7:7A	Submitted August 3, 2022; Update submitted January 13, 2023
NJDEP, DLRP	Section 401 Water Quality Certification	Section 401 of Clean Water Act (33 U.S.C. § 1341)	Coastal Zone Management Rules N.J.A.C. 7:7	Submitted August 3, 2022
NJDEP, Division of Water Allocation and Well Permitting	Dewatering Permit by Rule	New Jersey Water Supply Management Act, N.J.S.A. 58:1A-1	Water Supply Allocation Permit Rules N.J.A.C. 7:19	Submittal anticipated Q2/Q3 2023
NJDEP, Division of Water Quality	Stormwater Construction General Permit (5G3)	New Jersey Water Pollution Control Act N.J.S.A 58:10A	New Jersey Pollutant Discharge Elimination Program (NJPDES) Rules N.J.A.C. 7:14A	Submittal anticipated Q2/Q3 2023

Agency	Applicable Permit or Approval	Statutory Basis	Regulation	Anticipated Application Submittal Date or Consultation Status
NJDEP, Division of Water Quality	Short Term De Minimis General Permit (B7)	New Jersey Water Pollution Control Act N.J.S.A 58:10A	NJPDES Rules N.J.A.C. 7:14A	Submittal anticipated Q2/Q3 2023
NJDEP, Bureau of Tidelands Management	Tidelands License	Tidelands Act, N.J.S.A. 12:3	NA	Submitted August 19, 2022
NJDEP, Green Acres Program	Major Diversion of Parkland	New Jersey Green Acres Land Acquisition Act, N.J.S.A 13:8A	Green Acres Rules N.J.A.C. 7:36	Pre-Application and Part 1 of Final Application submitted June 10, 2022 Final Application Part 2 submittal December 22, 2022 State House Commission Approval Q1 2023
NJDEP, Division of Parks and Forestry, Natural Heritage Program	Threatened and Endangered Species consultation	New Jersey Endangered Species Conservation Act N.J.S.A 23:2A		Complete December 21, 2021 Updated Spring 2022 Updated January 13, 2023
NJDEP, NJHPO	NHPA Section 106 Consultation (completed by BOEM as part of the COP review and approval process)	New Jersey Register of Historic Places Act N.J.S.A 13:1B	36 CFR Part 60 - National Register of Historic Places;	In conjunction with BOEM COP review Section 106 meetings March 8, 2022, May 4, 2022, November 30, 2022. And February 22, 2023
		NHPA, 54 U.S.C. § 300101	36 CFR Part 800 - Protection of Historic Properties	In conjunction with BOEM COP review Section 106 meetings March 8, 2022, May 4, 2022, November 30, 2022, and February 22, 2023

Agency	Applicable Permit or Approval	Statutory Basis	Regulation	Anticipated Application Submittal Date or Consultation Status
NJDEP, Division of Parks and Forestry	Consultations and approvals for activities on State Lands and Parks	N.J.S.A 13:1B	State Park Service Code (N.J.A.C. 7:2-2.5)	State House Commission approval anticipated Q2 2023
New Jersey Department of Transportation (NJDOT)	Highway Occupancy Permit <sup>[2]</sup>	Highways N.J.S.A 27:1A-5 through 7	Highway Occupancy Permits N.J.A.C 16:41	Submittals anticipated Q2 2023
New Jersey Department of Community Affairs	Construction Permit	N.J.A.C. 5: 23 Uniform Construction Code	N.J.A.C. 5:23 2.1	Submittals anticipated Q2 2023
<b>County/Municipal Permits/Authorizations<sup>[3]</sup></b>				
Ocean County Soil Conservation District	Soil Erosion and Sediment Control Plan Certification	Soil Erosion and Sediment Control Act, N.J.S.A. 4:24	Chapter 251, P.L. 1975	Submittals anticipated Q2 2023
Cape Atlantic Soil Conservation District <sup>[4]</sup>	Soil Erosion and Sediment Control Plan Certification	Soil Erosion and Sediment Control Act, N.J.S.A. 4:24	Chapter 251, P.L. 1975	Submittals anticipated Q2 2023
County of Cape May Department of Engineering	Road Opening Permit		Board of Chosen Freeholders, Cape May County, New Jersey – Resolution No. 922-18	Submittals anticipated Q2/Q3 2023
Municipal/ county building and zoning permits and approvals <sup>[5]</sup>	Ocean City, Upper Township, Lacey Township, Ocean Township Cape May County, Ocean County	Various	Various	Lacey Township site plan for Oyster Creek substation approved September 12, 2022 BL England submittal anticipated Q2 2023

Note: this table does not list authorizations or filings associated with the production of electricity.

<sup>[1]</sup> Pending delegation of authority to NJDEP

<sup>[2]</sup> Construction permit (all others are planning permits).

<sup>[3]</sup> Information included only for the BL England Interconnect portion of the Project (Atlantic and Cape May Counties).

<sup>[4]</sup> Cape Atlantic Soil Conservation District serves Cape May and Atlantic Counties.

<sup>61</sup> Each municipality and county has a unique building, site plan, and zoning approval procedure. Additional permits and approvals such as roadwork, tree removal, land disturbance, and soil erosion and sediment control plans may also be required during the site plan approval process from counties and municipalities

## 2.3 Stakeholder Outreach

The Project has developed and is implementing a detailed stakeholder engagement matrix and communications plan. Ocean Wind puts great emphasis on stakeholder engagement throughout all phases of the Project life cycle and commenced stakeholder outreach at the start of the Project with a number of key parties and interest groups including Federal and State agencies, tribal nations, commercial fisheries, and environmental non-governmental organizations. The Project has invited the Narragansett Indian Tribe, the Shinnecock Indian Nation, and the Lenape Tribe of Delaware to pre-survey meetings in accordance with the Lease stipulations.

In March 2017 and July 2018, Ocean Wind conducted successful multi-agency meetings hosted by the NJDEP to outline its approach to developing the Project that were attended by many State and Federal agencies. In addition, Ocean Wind has attended numerous meetings with BOEM to discuss the baseline characterization work required for the COP.

In accordance with Lease stipulations, Ocean Wind submitted the following phased COP Survey Plans and has followed up with the applicable Federal and/or State agencies regarding specific survey plans as well as necessary survey permits, including application for incidental harassment authorizations (IHAs) to support geophysical and geotechnical survey work.

- COP Survey Plan, submitted April 17, 2018
- COP high-resolution geophysical and geotechnical (HRG&G) Phase 1a for Export Cable Route (ECR), submitted August 31, 2018, approved November 13, 2018
- COP HRG&G Phase GP1b, submitted January 28, 2019, approved April 24, 2019
- COP HRG&G GT2 Phase 1
  - Array Area, submitted February 9, 2019
  - ECR and Landfalls, submitted April 17, 2019
- HRG&G survey plans, submitted December 21, 2021, revised January 21, 2021, approved February 17, 2022
- Survey plan for potential UXO submitted April 19, 2022

Ocean Wind is committed to maintaining a strong working relationship with all commercial and recreational fishermen who may be affected by the Project. Ocean Wind has retained a Mid-Atlantic Fisheries Liaison, and Ocean Wind is actively participating in a variety of research initiatives. For example, Ocean Wind has entered into a Memorandum of Understanding (MOU) with Rutgers University and, under the terms of that MOU, launched an Ecosystem and Passive Acoustic Monitoring (ECO-PAM) project. As part of this project, Ocean Wind launched a New Jersey-based glider that will serve as an integral component of the research for offshore wind, advancing research for detection of North Atlantic right whales and characterization of their habitat in offshore wind lease areas. The ECO-PAM project is in partnership with the University of Rhode Island, Woods Hole Oceanographic Institution, and Rutgers University. Ocean Wind has also entered into a MOU with Stockton University and, under the terms of that MOU, supported a clinic for students and staff at Stockton University to be engaged in an ocean mapping training week. The overarching goal of the program was to expose undergraduate oceanography students to the technologies and opportunities available to assist in responsible ocean energy planning and implementation off New Jersey's coast. Additionally, Ocean Wind has entered into a MOU with Montclair University and, under the terms of that MOU, have five discrete scopes that are currently being executed, involving a variety of initiatives from the support of high school Science, Technology, Engineering, and Math (STEM) programs to the hosting of a roundtable to further engage stakeholders on offshore wind in New Jersey.

With the expansion of the Ocean Wind team, Ocean Wind has increased its fishing outreach as the Project develops. Ocean Wind has and will continue to conduct outreach to various fishing interests fishing within and transiting through the Project area. Over 270 interviews were conducted with commercial and recreational fishermen between July 2019 and September 2020. Outcomes and takeaways from these engagements can be summarized as follows:

- There is a wide variety of interest and a range of attitudes towards the Project;
- There is a strong interest in safe navigation and preserving the ability to fish within the Project area;
- The commercial fishing that does occur in the Project vicinity primarily includes squid and groundfish trawls, conch and lobster pots, and clam and scallop dredging;
- The limited number of mobile gear fishermen identified by outreach have indicated a preference for a layout which maximizes space between WTGs and;
- Fishermen desire to be as informed as possible in this process.

Ocean Wind developed a Fisheries Communication and Outreach Plan (Appendix O) in accordance with BOEM Guidelines; this plan outlines key strategies that Ocean Wind will use to communicate with fishermen and fishing industry representatives associated with the Project. The plan includes the appointment of a dedicated fisheries liaison as well as fisheries representatives who will serve as conduits for providing information to, and gathering feedback from, the fishing industry. An overview of the objectives of Orsted's Fisheries Communication and Outreach Plan is listed below.

- Focus on ways to avoid conflicts with fishermen within the wind energy lease areas.
- Identify all fisheries with a history of operations in or near Orsted U.S. Offshore Wind lease areas.
- Learn about the variety of fishing techniques used in Orsted U.S. Offshore Wind lease areas, their spatial requirements, and times of year fishermen use the area.
- Identify fishermen's concerns about offshore wind development and discuss ways to address those concerns.
- Identify and attend various fisheries working groups organized by state organizations.
- Enlist Fisheries Representatives in or near affected fisheries ports to advise about fishermen's concerns and construction and operation plans.
- Consult with fishermen to gain input and understand their concerns on siting of wind turbines to minimize the impact to fisheries, within the constraints of efficient energy generation.
- Develop informational documents and make them accessible to the fishing community.
- Design and implement effective strategies to alert fishermen to activities that could affect their operations.
- Identify knowledge gaps and discuss research priorities with fishermen.
- Develop effective channels for communication throughout the planning, construction, and normal operations phases to ensure safety of all individuals operating in the lease area.
- Work with fishermen to design and conduct a research program that provides scientifically credible information about the impacts of offshore wind farms on the marine environment and on the fishing industry.

In addition to this plan, Orsted has also developed a fishing gear conflict prevention and claim procedure.

**Table 2.3-1** summarizes outreach coordination.

**Table 2.3-1. Consultation with stakeholders.**

Date	Stakeholder	Summary of Discussion
April 2017	NJDEP	Initial Project kickoff meeting
	USACE - Philadelphia District	
	USFWS	
	NMFS	
April 2017	Environmental Protection Agency	Identify local recreational and charter fishing stakeholders. Conduct outreach to fisheries in the Mid-Atlantic.
	NMFS	Discuss planned high-resolution geophysical and geotechnical (HRG&G) surveys and role of the Fishery Representative in survey activities. Discuss opportunities to meet with NJ Marine Fisheries Council.
	NJDEP, Division of Fish & Wildlife, Bureau of Marine Fisheries	Outline of NJ Ocean Wind survey schedule and outreach to local fisheries groups.
June 2017	NJDEP, Division of Fish & Wildlife, Bureau of Marine Fisheries	Update on NJ Ocean Wind survey schedule and outreach to local fisheries groups.
	Mid-Atlantic Fishery Management Council	Advise on current expected schedule for HRG&G survey and outreach to fisheries groups.
August 2017	NMFS	Discuss Ocean Wind survey activities and possible presentation at a future Mid-Atlantic Fishery Management Council meeting.
September 2017	NMFS	Update on Ocean Wind outreach to fisheries groups both in Southern New England and the Mid-Atlantic.
December 2017	NMFS, Fishery Outreach, and BOEM	Update on Project development and progress of geotechnical survey of the area.
April 2018	NJDEP	Project kickoff meeting
July 2018	NJDOT	Project coordination meeting
	BOEM	Project desktop study meeting Section 106 meeting Project update and permit planning
	USACE - Philadelphia District	Project update and permit planning
	NJDEP - Multiple departments	
	NMFS	
	USFWS	
NJDOT	Project Introduction and request for contacts to review cable routes in state roads.	
NJDEP - all departments	Courtesy pre-application meeting and Project update to all NJDEP departments.	
August 2018	BOEM	Project kickoff meeting
		Project desktop study webinar
	NJDEP - Green Acres Program	Preliminary review of potential green acres impacts and review of rules

Date	Stakeholder	Summary of Discussion
September 2018	FAA	Project introduction meeting and expectations for wind turbine lighting and marking per FAA.
	USACE	Coastal Project coordination. Review of cable burial depth under federal beach re-nourishment projects.
	USCG	Headquarters, Waterways Management meeting
	Town of Lacey	General Project introduction and request to work with local engineers on cable routes.
	Ocean Township	
	NJDOT - Utility Management Unit	Review of cable routes utilizing state roads.
October 2018	Ocean City - Engineering Dept.	General Project information and updates. Review of cable routes.
	NJDEP, BOEM	Section 106 conference call
	NJDEP - DLUR	Route coordination with Division's Threatened & Endangered Species Unit
	NJDEP - Marine Fisheries	Project coordination regarding proposed cable routes
	Office of the Assistant Secretary of Defense	Provided informal review by the DOD Military Aviation and Installation Siting Clearinghouse
	North American Aerospace Defense Command	Project siting and coordination
	New Jersey Turnpike Authority	Review of cables route along Garden State Parkway in Upper Township
November 2018	USCG	USCG Aviation Operations
	NJDEP - Marine Fisheries	Project coordination regarding proposed cable routes
	DOD	Siting Clearinghouse, Readiness Sustainment and Compatibility meeting
	BOEM	Project site investigations meeting
	Upper Township	Local municipality meeting
	NJDOT Office of Marine Resources	Navigation channel conference call
December 2018	BOEM	Native American Tribe meeting
	Township of Ocean, Township of Lacey	Local municipality meeting
	NJDEP - Office of Permit Coordination and Environmental Review	Project coordination meeting
	USCG	Delaware Bay Sector coordination, Waterways Management meeting
January 2019	USCG	Delaware Bay Sector coordination
	Mariners Advisory Committee for the Bay and River	Project coordination meeting.
March 2019	USACE	Coastal Projects meeting.
	USCG	Search and Rescue introduction conference call.



Date	Stakeholder	Summary of Discussion
	USCG, BOEM	District 5, Sector Delaware Bay, Air Station Atlantic City - introduction to the Ocean Wind Project, Navigation Safety Risk Assessment, and continued coordination
	USFWS, Galloway NJ	General project discussion.
April 2019	Lenape Tribe of Delaware	Upcoming Project surveys within the Lease Area and export cable route
	Mid-Atlantic Fisheries Management Council	General project update
May 2019	Ocean County Administration and Engineering	Cable route planning
June 2019	BOEM	COP update meeting
July 2019	NJDEP - Office of Permit Coordination and Environmental Review	Project coordination meeting
	Atlantic City Mayor's Office	Local municipality meeting
	U.S. Marine Corps	Military flights
August 2019	Atlantic City Engineering (Maser) and other departments	Local municipality meeting
	Atlantic City Community Meeting & Open House	Introductory open house/community meeting
	Ocean City Community Meeting & Open House	
	Waretown Community Meeting & Open House	
September 2019	Barnegat Bay Partnership	General project meetings with a consortium of Ocean County stakeholders.
	Ocean City	General project update and field trip to tour flood-prone areas
	Clean Ocean Action	General project update
October 2019	NJDEP Commissioner's Office	Stakeholder outreach update
	Township of Ocean	General project update
	Township of Lacey	General project update
	New Jersey Audubon	General project update
	NJ Environmental Justice Alliance	General project update
November 2019	Monmouth University and Montclair University	Partnership scoping
	NJ Audubon	Project update to discuss avian assessment
	NJ Non-Governmental Organizations	Project update and introduction meeting
	NJDEP Commissioner's Office	Stakeholder outreach update
	Atlantic City	General project update
	Longport	General project update
	Atlantic County	General project update
	Cape May County	General project update
December 2019	Ocean City	General project update
	City of Longport	General project update
	Ventnor	General project update
	Upper Township	General project update
	Ocean County	General project update

Date	Stakeholder	Summary of Discussion
January 2020	New Jersey Historic Preservation Office	APE and Assessment of Visual Effects on Onshore Historic Properties Methodology
	NJDEP Division of Land Use Regulation	Federal Coastal Zone Consistency
	Ventnor	General project update
	Brigantine	General project update
	Responsible Offshore Development Alliance (RODA) Meetings, Cape May, Atlantic City, Barnegat Light, and Task Force	General project update
February 2020	Sea Isle City	General project update
	Avalon	General project update
	Stone Harbor	General project update
	Wildwood Crest	General project update
	Cape May	General project update
	Atlantic City Community Meeting & Open House	Open house/community meeting
	Ocean City Community Meeting & Open House	
	Waretown Community Meeting & Open House	
	NJDEP Division of Land Use Regulation	Project update and permitting discussions
May 2020	U.S. EPA Region 2, NJDEP Division of Air Quality	Project update and permitting discussion
June 2020	Mariner's Advisory Committee	Project update
July 2020	RODA meeting	Project update meeting and Project layout discussion
	NJ Audubon and environmental non-governmental organizations	Project update meeting
September 2020	USCG (Members from HQ, District 5, Sector Delaware Bay, Station Atlantic City)	Navigation safety and search and rescue Operations
	Mariner's Advisory Committee	Project update
	US Maritime Administration (Administrator)	Navigation safety
October 2020	Environmental Non-Governmental Organization Workshop	Discuss project construction methodology
	Virtual Open Houses	Open house/community project update meeting
November 2020	Upper Township	General project update
December 2020	NJDEP	Oyster Creek interconnection point pre-application meeting
	NJDEP	Fisheries meeting
	Mariner's Advisory Committee	Project update
January 2021	NJDEP and USFWS	Rare, threatened and endangered species meeting
	Township of Ocean	General project update
	Township of Lacey	General project update
	NJ Department of Transportation	General project update and discussion of permitting requirements.

Date	Stakeholder	Summary of Discussion
February 2021	USCG Atlantic Area Commander	General Project update, with emphasis on navigation safety
	Ocean City	General project update
	Atlantic City	General project update
March 2021	Mariners Advisory Committee	Project Update
	NJ Historic Preservation Office and BOEM	Update on Ocean Wind's Visual Effects on Historic Properties Assessment
	Atlantic City	Update on Ocean Wind's Visual Effects on Historic Properties Assessment
	Ventnor	Update on Ocean Wind's Visual Effects on Historic Properties Assessment
	Stone Harbor	Update on Ocean Wind's Visual Effects on Historic Properties Assessment
	NJDEP and NOAA Fisheries	Fisheries meeting
April 2021	USACE	General project update and Section 408
	USFWS	Rare, threatened and endangered species meeting
May 2021	NJDEP	General Project update meeting
		Green Acres Program update; Island Beach State Park state lands lease coordination
	U.S Navy Fleet Forces Command	Project update
	USCG District 5	Project update boundary setback – NOI comments
June 2021	USCG District 5	Air assets search and rescue discussion
	Mariners Advisory Committee	Project update
	USCG District 5	Marking and lighting discussion
	USCG Headquarters	Comments to NOI setback
	USN Fleet Forces	UXO Response
July 2021	NJDEP	Green Acres Program pre-appraisal meeting
	NMFS	Barnegat Bay alternatives meeting
	NJDOT Office of Maritime Resources	General Project update; crossing of Oyster Creek Channel
	American Waterway Operators and Tug/Tow Industry	Project update - navigation safety (MITAGS)
August 2021	NJDEP	Dredging and sediment sampling plan coordination
	Recreational Boaters	Project Update – navigation safety (MITAGS)

Date	Stakeholder	Summary of Discussion
	USCG Headquarters and District 5, Sector Delaware River, National Academies of Science	Project Update – navigation safety (MITAGS)
	NMFS and BOEM	Incidental Take Authorization kickoff call
September 2021	NJDEP	Permit plan walkthrough and coordination
	USACE and NJDEP	Ocean City landfall and Section 408
	NJDEP, USACE, and NJDOT Office of Maritime Resources	Dredging and sediment sampling plan coordination
	NJDEP	Tidelands Bureau and Green Acres Program update; Island Beach State Park Land and Water Conservation Fund coordination
October 2021	NJDEP	Wetland delineation and letter of interpretation coordination; Green Acres Program update; Stormwater management coordination; Island Beach State Park State Lands Lease coordination
	NJDEP and BOEM	Island Beach State Park alternatives coordination
	New Jersey Pinelands Commission	Pinelands Commission coordination
	USCG Headquarters	Project update discussion about virtual aids to navigation
November 2021	Ocean City	General Project update public open house
	NJDEP, Garden State Seafood Association	Pre-application meeting
		Green Acres Program appraisal coordination
	USCG District 5	Private aids to navigation
	New York Department of State	Cable routing
NMFS and BOEM	Meetings following submission of ITA application to discuss content and approach	
December 2021	NJDEP	General Project update/milestone schedule review
		Survey/Sediment Sampling Analysis Plan coordination
		BL England wetland delineation discussion
	USEPA and NJDEP	Air Dispersion Modeling Protocol Discussion
	Native American Tribes	Tribal Pre-Survey Meeting
January 2022	NJDEP	Bureau of Tidelands - License Coordination
		Project update and design plan coordination meeting

Date	Stakeholder	Summary of Discussion
		Island Beach State Park coordination meeting
	Ocean City	Green Acres Scoping Hearing coordination meetings for Ocean City diversion (public meeting)
	BOEM	Survey Plan coordination
		Fisheries monitoring survey coordination
	NMFS and BOEM	Discussion of NMFS comments to revised ITA application
USEPA, NJDEP	OCS air permit coordination	
February 2022	USACE and BOEM	Pre-Application Meeting for Section 404/10 Permit
		Wetland delineation and verification coordination
	USFWS and BOEM	Red knot survey work update
	USFWS, USEPA, and NJDEP	Air Quality Related Values (AQRV) Analysis Discussion for Class I area (Edwin B. Forsythe National Wildlife Refuge)
	NJDEP	Island Beach State Park geotechnical survey equipment access/storage coordination
	Native American Tribes	Tribal outreach follow up meeting (attended by the Delaware Tribe of Indians)
March 2022	BOEM, NMFS, and USACE	Construction schedule and potential work windows within Barnegat Bay
	USEPA and NJDEP	OCS Air Permit Pre-application Meeting
	NJDEP	Geotechnical survey permitting coordination
		Wetland delineation and verification coordination
	Native American Tribes	Barnegat Bay submerged aquatic vegetation (SAV)
Native American Tribes	Section 106 Consulting Party Meeting 1	
April 2022	NJDEP	SAV monitoring coordination
May 2022	NMFS and BOEM	Discuss ITR application
	USFWS and USEPA	Discuss AQRV analysis inputs, review OCS source modeling, air permit coordination
June 2022	USEPA	Discuss OCS source modeling, air permit coordination

Date	Stakeholder	Summary of Discussion
	NJDEP	Oyster Creek Alternatives Meeting
	NJDEP - Green Acres Program	Discuss Green Acres diversion application
	NMFS and Marine Mammal Commission	Discuss ITR application
	Native American Tribes	Potential UXO inspection tribal pre-survey meeting (attended by the Delaware Tribe of Indians)
	Ocean Township	Update on onshore survey work, request for access to perform necessary survey work
	Lacey Township	Update on onshore survey work, request for access to perform necessary survey work
	Ocean County	Update on onshore survey work, request for access to perform necessary survey work
	Rowan University	Workforce development, supply chain, research and development
	Save Barnegat Bay	Barnegat Bay and Island Beach State Park Impacts
	NJDOT	Discuss DOT onshore permits
July 2022	NMFS	Discuss ITR application
	NJDEP	Quarterly Project update
	NJDOT	Discuss DOT onshore permits
	Upper Township	BL England substation relocation
August 2022	USFWS and USEPA	Discuss AQRV analysis, OCS source modeling, air permit coordination
	NMFS and Marine Mammal Commission	Discuss ITR application
	NMFS and BOEM	Monitoring and mitigation for proposed nighttime piling
	NJHPO and BOEM	BOEM Draft Environmental Impact Statement and COP comment review
	NJDOT	Discuss DOT onshore permits
	NJDEP - Green Acres Program	Discuss Green Acres diversion application
	Native American Tribes	Geotechnical survey tribal meeting (attended by the Delaware Tribe of Indians and the Stockbridge Munsee Tribe)
	Jersey Coast Shark Anglers Association	Project updates
	Lacey Township	Project update
	Upper Township	Substation relocation

Date	Stakeholder	Summary of Discussion
	Save Barnegat Bay	Barnegat Bay and Island Beach State Park Impacts
September 2022	USEPA	Discuss EPA comments on the revised OCS air permit application submitted July 2022
	USACE	Discuss geotechnical boring permit revision
	USCG	Update to USCG Sector Delaware Bay and District 5 staff – project timelines, lighting and marking
	Mariners' Advisory Committee (MAC) – Delaware River and Bay	General update on Orsted projects
	NJDEP	Draft Barnegat Bay SAV Restoration and Mitigation Plan; BL England Substation Relocation Discussion
	NMFS	Discuss ITR application
	NMFS and BOEM	Monitoring and mitigation for proposed nighttime piling
	NJDEP - Green Acres Program	Discuss Green Acres diversion application
	NJDOT	Discuss DOT onshore permits
	USFWS	Suitable habitat assessments
	Stone Harbor Property Owners Association	Project overview
	Chamber of Commerce of Southern NJ	Project update
	Lacey Township	Oyster Creek Substation Site Plan Hearing
	Upper Township	Notice of acoustic survey work
Ocean City	Notice of acoustic survey work	
October 2022	USFWS and USEPA	Discussion on the updated AQRV analysis
	USFWS and BOEM	Discuss request for information to support BOEM's ESA consultation
	NMFS	Discuss ITR application
	NJDEP	Discuss geotechnical boring permit revision; Ocean Wind NJDEP Supplemental Information for application for Waterfront Development, Wetlands Act of 1970, CAFRA, Flood Hazard Control Act and Freshwater Wetlands Protection Act Individual Permit
	BOEM, NJDEP, USACE, FWS, NMFS	SAV Mitigation
	EPA	Modelling discussion

Date	Stakeholder	Summary of Discussion
	Association of New Jersey Environmental Commissions (ANJEC)	Project overview at ANJEC Environmental Congress
November 2022	USEPA	Discuss EPA comments on the revised OCS air permit application
	NMFS	Discuss ITR application
	NMFS and BOEM	Discuss monitoring and mitigation for proposed nighttime piling
	Native American Tribes and Consulting Parties	Section 106 Consulting Party Meeting
	NJDEP - Green Acres Program	Ocean Wind hosted final Green Acres hearing
	Upper Township	Public meeting
December 2022	USACE	Discuss Preliminary Draft Barnegat Bay SAV Restoration and Mitigation Plan
	NJDEP	Discuss Preliminary Draft Barnegat Bay SAV Restoration and Mitigation Plan; CAFRA/Island Beach State Park (IBSP) Mitigation Project discussion; discuss Waterfront Development/Coastal Wetlands permit application re-submission; Public hearings
	NJDEP – Green Acres Program	Green Acres compensation discussion
	NMFS and BOEM	Discuss Preliminary Draft Barnegat Bay SAV Restoration and Mitigation Plan
	NMFS	Discuss ITR application
	NMFS and BOEM	Discuss monitoring and mitigation for proposed nighttime piling
January 2023	USEPA	Discuss EPA comments on the revised OCS air permit application
	USEPA	Discuss EPA comments on the modeling approach included in the OCS air permit application
	USACE	Discuss Section 10 and 408 of Rivers and Harbors Act of 1899 and Section 404 of the Clean Water Act Individual Permit modification
	NMFS	Discuss ITR application
	NMFS and BOEM	Discuss monitoring and mitigation for proposed nighttime piling
	NJDEP	Discuss Ocean Wind NJDEP Waterfront Development and Coastal Wetlands



Date	Stakeholder	Summary of Discussion
		Individual Permit; discuss updates to Tidelands License applications
	USACE, NJDEP, NJDOT	Discuss agency comments on BL England HDD alignment
	NJDEP – Green Acres Program	Discuss Green Acres application and State House Commission meeting preparation
	USFWS	Avian and Bat post-construction monitoring framework discussion
February 2023	NJDEP	EPA air permit update; discuss general project updates related to pending applications/permit schedule
	USEPA	Discuss EPA comments on the modeling approach included in the OCS air permit application
	NMFS	Discuss ITR application
	USFWS and BOEM	Discuss request for information to support BOEM’s ESA consultation
	Native American Tribes and Consulting Parties	Section 106 Consulting Party Meeting
	NJDEP – Green Acres Program	Discuss Green Acres application and State House Commission meeting preparation
	USACE	Discuss Section 10 and 408 of Rivers and Harbors Act of 1899 and Section 404 of the Clean Water Act Individual Permit modification
March 2023	NJDEP	Sediment modelling, permit plans
	USACE	Discuss Section 10 and 408 of Rivers and Harbors Act of 1899 and Section 404 of the Clean Water Act Individual Permit modification
	NMFS	Discuss ITR application
	USEPA	Discuss EPA comments on the modeling approach included in the OCS air permit application
April 2023	NJDEP	Discuss application comments

Ocean Wind conducts bi-monthly Project coordination calls with NJDEP (started Q4 2018) and BOEM (Q1 2018). Ocean Wind coordinated with stakeholders for development of plans to conduct high-resolution geophysical (HRG) surveys for the offshore component of the Project. During the surveys themselves, Ocean Wind coordinated on a regular basis with the fishing community, federally recognized Native American tribes, and mariners, including issuing Notices to Mariners.

In September 2019 Orsted hosted representatives from the U.S. Coast Guard, Delaware Bay Pilots, commercial fishing (RODA) industry and others in Grimsby, England. Participants learned from the members of the UK's Maritime and Coast Guard agency of the impeccable safety record of offshore wind and toured the Race Bank wind farm aboard a crew transfer vessel. The event provided participants an increased level of comfort and familiarity with offshore wind developments. Orsted recognizes it is not practical to bring significant numbers of stakeholders to England (or Germany or Taiwan) to navigate within wind farms, so the Marine Affairs Team engaged two of the leading US vessel navigation simulation centers, Maritime Institute of Technology and Graduate Studies (MITAGS) in Linthicum Heights, Maryland and United States Maritime Resource Center (USMRC) in Middletown, Rhode Island, to develop exacting models of the proposed Ocean Wind development and Revolution Wind development, respectively. The concept is to bring various stakeholder groups to the facilities to participate in hands-on demonstrations within the navigation simulators. The simulator provides key maritime stakeholders, regulators, and others the opportunity to “navigate” near or among wind farm arrays and provides first-hand understanding of scale and navigability of simulated turbine arrays, especially navigation safety and search and rescue operations. Through this Simulation, Orsted has provided a hands-on method for testing the practicality of various aspects of proposed arrays, including layout, lighting, marking, and search and rescue corridors.

The Project has developed a systematic and strategic approach to bringing the Project to local communities for their feedback and input. The key stakeholder groups include the coastal communities in the Project Area. The Ocean Wind team has engaged numerous mayors and representatives in coastal communities including:

- Ocean City
- Upper Township
- Lacey Township
- Ocean Township
- Margate
- Longport
- Brigantine
- Atlantic City
- Avalon
- Stone Harbor
- Sea Isle City
- Cape May
- North Wildwood
- City of Wildwood
- Ventnor
- Wildwood Crest

Ocean Wind has been engaging in its home communities since acquiring the Lease in May 2016. This includes participation in panels, networking events, conferences, symposiums, and receptions.

Ocean Wind has also extended invitations for pre-survey meetings and project updates to representatives of 15 Native American tribes, many of which are federally recognized:

- Absentee-Shawnee Tribe of Indiana of Oklahoma
- The Delaware Nation
- Delaware Tribe of Indians
- Eastern Shawnee Tribe of Oklahoma
- Shawnee Tribe
- Stockbridge-Munsee Community Band of Mohican Indians
- The Narragansett Indian Tribe
- The Shinnecock Indian Nation
- Nanticoke Indian Association, Inc.
- Nanticoke Lenni-Lenape Tribal Nation
- Nanticoke Lenni-Lenape Tribe
- Powhatan Renape Nation
- Ramapough Lenape Indian Nation
- Ramapough Mountain Indians
- Lenape Indian Tribe of Delaware

Ocean Wind's stakeholder outreach is ongoing. Proper noticing and advertising for these outreach meetings will take place in order to make sure all interested parties have been notified and given the opportunity to comment on the Project. The following list includes, but is not limited to, the groups that will be consulted throughout the process:

- Residents Against Giant Electric
- NJ Audubon Society
- ReClam the Bay
- Lund's Fisheries

- Ocean City Fishing and Cruising Fleet
- Atlantic Cape Fisheries, Inc.
- Atlantic Offshore Lobsterman Association
- Oceanside Marine LLC
- Seawatch International
- The Nature Conservancy
- American Waterways Operators
- Mariners Advisory Committee (MAC) for the Bay and River Delaware
- The New Jersey Boatmen
- The Area Maritime Safety Committee
- Recreational Fisherman’s Alliance
- Responsible Offshore Development Alliance (RODA)

A summary of engagement with stakeholders outside of regulatory agencies and the Tribes is provided in **Table 2.3-2.**

**Table 2.3-2. Stakeholder engagement.**

Stakeholder	Summary of Engagement
<b>All Stakeholders</b>	<ul style="list-style-type: none"> <li>• Public Open House: Waretown February 2020</li> <li>• Public Open House: Atlantic City February 2020</li> <li>• Public Open House: Ocean City February 2020</li> <li>• Public Open Houses: three virtual sessions October 2020</li> <li>• Public Open House: Ocean City November 2021</li> </ul>
<p><b>Fishing Communities &amp; Other Offshore Stakeholders</b> are important stakeholders with which the Project strives to achieve co-existence the Lease Area.</p>	<ul style="list-style-type: none"> <li>• Corporate Fisheries Liaison focused on working with fisheries organizations to achieve broad engagement within sectors of the fishing industry.</li> <li>• Keep current the “Mariners” section of the Orsted website which includes the most current briefing of Ocean Wind survey activity <a href="https://us.oreded.com/Mariners">https://us.oreded.com/Mariners</a>.</li> <li>• Developed Fisheries Communication and Outreach Plan for Orsted U.S. Offshore Wind.</li> <li>• Distributed Notices to Mariners in both electronic and hard-copy format to share information regarding offshore survey activities.</li> <li>• Partnered with the RODA to create an opportunity for commercial fishermen to provide direct input to the wind energy industry.</li> <li>• Attend and participate in fisheries trade events such as American Fisheries Society Annual Meeting in August 2018 and September 2020.</li> <li>• Participated in the Atlantic City Boat Show to engage with recreational boating community in February 2019 and February 2020.</li> <li>• Reconfigured Project layout based on extensive feedback from fisheries interests, US Coast Guard, and RODA to incorporate appropriate vessel transit movement.</li> <li>• Met with North American Submarine Cable Association (NASCA) to discuss export cable configuration and terms for potential crossing agreements.</li> <li>• Holds regular weekly open port hours.</li> <li>• Posted an online survey for stakeholders to share their use of the Project area and communicate any concerns.</li> <li>• Distributed a Marine Affairs Newsletter in January 2021 to showcase the department and Orsted Offshore North America Projects.</li> <li>• Partnered with Maritime Institute of Technology and Graduate Studies (MITAGS) to create an exacted model of the Ocean Wind Farm for use with the bridge simulator to provide an opportunity to simulate navigating through the wind farm.</li> <li>• Provide quarterly project updates to the MAC.</li> <li>• Held a virtual meeting in January 2022 to inform stakeholders, including Lunds, Atlantic Capes, GSSA, and ROSA, of collaboration with Atlantic Shores to develop a proposed alternative submitted to BOEM to address boundary setback concern raised by the USCG.</li> <li>• Held a Project overview meeting in February 2022 in Sea Isle City, New Jersey</li> </ul>

Stakeholder	Summary of Engagement
	Attended by roughly one dozen conch fishermen.
<p><b>Labor and Local Business Interests</b> can benefit from the Project through job creation, local purchasing of supplies and equipment and other development and operations support opportunities.</p>	<ul style="list-style-type: none"> <li>• Executed a Memorandum of Understanding with the South Jersey Building Trades in February 2018.</li> <li>• Hosted a high-level project briefing for a number of stakeholders, including members of labor and local business/economic development organizations, in May 2019 and September 2019.</li> <li>• Maintain active involvement with Alliance for Action, Cape May County Chamber of Commerce, The Greater Atlantic City Chamber of Commerce, Chamber of Commerce of Southern New Jersey, Greater Toms River Chamber of Commerce, Monmouth Ocean Development Council, Southern Ocean County Chamber of Commerce, Atlantic County Economic Alliance, New Jersey Energy Coalition, the Southern New Jersey Development Council and New Jersey Business &amp; Industry Association.</li> <li>• Attended meetings and presented to business organizations to share updates on offshore wind and Ocean Wind’s plan, including Atlantic City Economic Development Advisory Committee, Monmouth Ocean Development Council, Southern Ocean County Chamber of Commerce, Chamber of Commerce of Southern New Jersey, the New Jersey Business and Industry Association, and the R&amp;D Tech Council of New Jersey.</li> <li>• Executed a memorandum of understanding with North America’s Building Trades Unions (NABTU) to develop workforce training programs in November 2020.</li> </ul>
<p><b>Environmental Organizations</b> including but not limited Surfrider Foundation, Patcong Creek Foundation, The Wetlands Institute, Urban Coast Initiative, NJ Environmental Lobby, Sustainable Jersey, Citizens Climate Lobby, NJ Audubon Society, Marine Mammal Stranding Center, the New Jersey Corporate Wetlands Restoration Partnership, and Environment New Jersey</p>	<ul style="list-style-type: none"> <li>• Held and attended meetings with environmental organizations to gather input, hear concerns, and share updates regarding Ocean Wind’s plans and activity status.</li> <li>• Sponsored various events and programs in support of environmental organizations, including: Sustainable Jersey; Friends of Island Beach State Park; The Marine Mammal Stranding Center’s Dancing with Dolphins Annual Fundraiser; The New Jersey Environmental League Awards; The NJ Work Environment Council Awards Dinner; New Jersey Audubon Society’s World Series of Birding; The Nature Center of Cape May’s “Catch of Cape May” and The Wetlands Institute’s horseshoe crab program ReTURN the Favor NJ, in which Orsted employees also participated.</li> <li>• Contributed funding to Whale Alert App.</li> <li>• Maintain membership in The New Jersey Corporate Wetlands Restoration Partnership.</li> </ul>

Stakeholder	Summary of Engagement
<p><b>Local Communities</b> have the potential to be directly impacted by construction and operation of the Project and Ocean Wind is committed to engaging with these communities to share information and minimize potential disturbance.</p>	<ul style="list-style-type: none"> <li>• Met with and continue ongoing coordination in the following communities local to the Project’s potential landfall locations: Ocean Township, Lacey Township, Ocean City, Upper Township, Ocean County and Cape May County.</li> <li>• Met with the following mayors and business administrators in Atlantic and Cape May County coastal communities during summer/fall 2018 and fall 2019 to brief them on project: Atlantic City, Ocean City, Margate, Longport, Ventnor, Avalon, Stone Harbor, Sea Isle City, Cape May, North Wildwood, Wildwood Crest, as well as Galloway Township in February 2018 and the Atlantic County Parks and Environmental Commission in October 2018. Continued project updates in coastal communities since 2019 (see <b>Table 2.3-1</b>).</li> <li>• Active presence on social media to provide up-to-date information on surveys and other Project activities.</li> <li>• Maintain involvement and support of several local and regional organizations, including: Boys and Girls Club of Atlantic City; Atlantic City Air Show; NJ Friends of the Guard and Reserve, Community FoodBank of New Jersey, Southern Branch; EarthShare NJ, Jersey Shore Partnership; Atlantic City Police Foundation; Atlantic City, Ventnor, Margate and Longport Green Teams; American Heart Association; and NJ Coast Guard Foundation.</li> <li>• Hosted FLiDAR Buoy Launch event in Atlantic City in July 2018 to educate public about the geophysical and geotechnical work undertaken as part of project.</li> <li>• Participated in the New Jersey League of Municipalities in November 2018 and 2019.</li> <li>• Hold membership in the New Jersey Conference of Mayors.</li> </ul>
<p><b>Universities</b> can provide a wealth of valuable data and have served as leaders in both science and job training.</p>	<ul style="list-style-type: none"> <li>• Worked with several area universities and institutions to support primary research in offshore wind-related fields of study including Stockton University, Rowan University and Rutgers University.</li> <li>• Executed a Memorandum of Understanding with Stockton University in March 2019 to provide funding to assist in promoting educational programming related to alternative energy, climate change and resiliency.</li> <li>• Executed a Memorandum of Understanding with Rutgers University in May 2019 to support academic research activities related to offshore wind.</li> <li>• Executed a Memorandum of Understanding with Rowan University in April 2019 to support innovative offshore wind engineering clinics.</li> <li>• Developed an MOU with Montclair University to host a Wind Energy Roundtable session for stakeholders; support clean energy and sustainability analytics research; support student and faculty researcher participation in outreach and dissemination through presenting at workshops, conferences, and meetings; and support STEM initiatives including a summer camp in 2020 and other related programs.</li> <li>• Hosted a high-level project briefing for a number of stakeholders, including members the academic community, in May and September 2019.</li> <li>• Participated in the Rutgers Energy Institute Symposium in May 2019.</li> <li>• Provided undergraduate and graduate-level lectures at Monmouth University and a number of colleges and universities throughout New Jersey.</li> </ul>

### 3. Ocean Wind’s Purpose and Need of the Proposed Action

The purpose of the Project is to develop a wind generation project within the BOEM Lease Area (OCS-A 0498) that meets the need for competitively priced renewable energy and additional capacity in accordance with State and regional renewable energy demands and goals. Under the New Jersey OWEDA, the NJBPU is required to establish an Offshore Wind Renewable Energy Certificate (OREC) program requiring a percentage of electricity

sold in the state be from derived from offshore wind energy, in order to support at least 1,100 MW of generation from qualified projects. On June 21, 2019, the NJBPU selected the Ocean Wind Project. The Project is expected to deliver first power in late 2024 or early 2025.

New Jersey has a need for additional renewable energy generation to meet State renewable energy goals. New Jersey's OWEDA (NJSA 48:3-49) was signed in August 2010 and mandates the development of a minimum of 1,100 MW of offshore wind resources when there is a demonstrated net economic benefit for New Jersey. OWEDA directed the NJBPU to establish an OREC Program and to establish an application process for interested Offshore Wind developers to apply to be eligible to receive ORECs.

In January 2018, New Jersey Governor Phil Murphy signed Executive Order 8 reestablishing OWEDA, setting an energy goal of 3,500 MW by 2030 and directing the NJBPU to move forward with developing the OREC process. In November 2019, Executive Order 92 increased the goal to 7,500 MW by 2035. In September 2022, Governor Murphy signed Executive Order 307, increasing New Jersey's offshore wind energy goal by nearly 50 percent to 11,000 MW by 2040.

Assembly Bill 3723, which passed in the State Senate on May 23, 2018, established that by 2020, 21 percent of the kilowatt hours sold in the State by each electric power supplier and each basic generation service provider be from Class I renewable energy sources. It goes on to set goals to achieve 35 percent renewables by 2025, 50 percent by 2030, and 100 percent by 2050. The Ocean Wind Project will promote and help New Jersey achieve its renewable energy generation goals as outlined in the *Draft 2019 New Jersey Energy Master Plan, Policy Vision to 2050*<sup>4</sup>, released in June 2019. Ocean Wind will create over 3,000 direct jobs through development and an approximately three-year construction cycle<sup>5</sup>. Upon startup the Project will power approximately 500,000 New Jersey homes and promote and help New Jersey achieve its ambitious renewable energy generation goal of supplying more than 1.5 million New Jersey homes with offshore wind power.

On June 21, 2019, the NJBPU selected the Ocean Wind Project to develop the offshore wind farm proposed in this COP. On December 4, 2020, Orsted announced that it had entered into an agreement to sell a 25% ownership interest in the Ocean Wind Project to New Jersey's Public Service Enterprise Group (PSEG). In March 2021, the New Jersey Board of Public Utilities approved the sale by Orsted to PSEG. The joint ownership structure utilizes the respective capabilities and experience of the parties.

## 4. Project Description

The Lease Area will be developed for the Project, as further described in Sections 4.1 and 4.6. Pursuant to 30 CFR 585.626, this Project description details all planned facilities, including offshore, onshore and support facilities.

This Project description provides a reasonable range of Project designs to accommodate refinements following BOEM review and during detailed design. The design parameters assessed throughout the COP represent the maximum anticipated impact design for each resource. The PDE for each component is described in the relevant section of Section 6.

The physical dimensions of potential wind turbines are provided rather than turbine rated capacity. With advancements in wind turbine design, turbine capacity is less indicative of overall design parameters and may vary depending on site conditions. In addition, environmental impacts are generally related to physical

---

<sup>4</sup> Available at <https://nj.gov/emp/pdf/Draft%202019%20EMP%20Final.pdf>.

<sup>5</sup> The estimate was generated by utilizing the R/ECON model, with the assistance of Rutgers Bloustein School. See Volume II Section 2.3.1.2.1 for additional detail.

dimensions, such as turbine height and rotor diameter, rather than capacity. Therefore, it is more appropriate to constrain the design envelope based on physical dimensions rather than turbine capacity.

## 4.1 Ocean Wind Project Location

### 4.1.1 Boundary

The boundaries of the Project Area are depicted on **Figure 1.1-1** and specifically consist of:

- Wind Farm Area: This is the area where the turbines, array cables, offshore substation(s), substation interconnector cables, and portions of the offshore export cables are located;
- Offshore export cable route corridor: Area in which the offshore export cable systems will be installed;
- Onshore export cable route corridor: Area in which onshore export cable systems will be installed, including onshore export cables) and grid connections; and
- Onshore substations.

The Wind Farm Area is located within Federal waters. The offshore export cable route corridor(s) will be partially located in Federal waters and partially in New Jersey waters. The onshore export cable route corridor(s) will be located within New Jersey. The Project boundary does not include interconnection upgrades or non-Project specific O&M and port facilities.

During construction, the Project will involve temporary construction laydown areas and construction ports. The primary ports that are expected to be used during construction, but which have independent utility and are not dedicated to the Project, are as follows:

- Atlantic City, NJ - construction management base. The site area is intended to offer an opportunity for a combined base for crew transfer vessel (CTV) operations for the construction phase.
- Paulsboro, NJ or Europe (directly) - for foundation scope. The port area is intended to offer an opportunity for both foundation fabrication facilities as well as staging and load-out operations in collaboration with a key subcontractor.
- Norfolk, VA or Hope Creek, NJ - for WTG scope. The port area is intended to offer an opportunity for WTG pre-assembly and load-out facility without any air draft clearance restrictions covering jack-up installation vessel assets.
- Port Elizabeth, NJ, Charleston, SC, or Europe (directly) - cable staging (unless transported directly from the cable supplier). The intended terminal area and quay infrastructure will be used for various cable staging and operation activities, if required.

During operations, Ocean Wind intends to utilize an O&M Facility in Atlantic City that will serve as a regional operations and maintenance center for multiple Orsted projects in the mid-Atlantic, including the Project. This facility is discussed in Section 6.2.3.1.

### 4.1.2 The Lease Area and Location Plat

The Commercial Lease of Submerged Lands for Renewable Energy Development on the Outer Continental Shelf (Lease Area OCS-A 0498) from BOEM allows Ocean Wind the exclusive right to seek BOEM approval for the development of a leasehold. The lease allows Ocean Wind the exclusive right to submit a SAP and a COP, and to conduct activities in the leased area that are described in the SAP or COP as approved by BOEM.

On December 8, 2020 Ocean Wind requested that BOEM segregate portions of 160,480-acre original Lease Area OCS-A 0498 into a new lease area of approximately 84,955 acres (**Figure 1.1-1**). On March 26, 2021, BOEM approved this request with this area designated a new lease number (OCS-A 0532) and assigned to a

separate affiliate of Orsted. Ocean Wind is continuing to develop the Project on the remaining portions of Lease Area OCS-A 0498, which is approximately 75,525 acres (**Figure 4.1-1**).

The portion of the Lease Area that the offshore infrastructure, including turbines, offshore substations, and array and substation interconnector cables would be located is referred to as the Wind Farm Area.

(**Figures 4.1-1** and **4.1-2**). Water depths in the Wind Farm range from 49-118 ft below mean lower low water (MLLW) with the seabed sloping generally offshore toward the southeast at less than 1°. The Wind Farm Area is approximately 68,450 acres.

Approximate locations for the offshore turbines and offshore substations are provided in Appendix G. The results of HRG surveys will be used to inform decisions regarding micro-siting to avoid boulders or other features. To allow for micro-siting of Project offshore infrastructure, the HRG survey area has been designed to be larger than the actual area of impact for the WTGs, offshore substations, and cable routes.



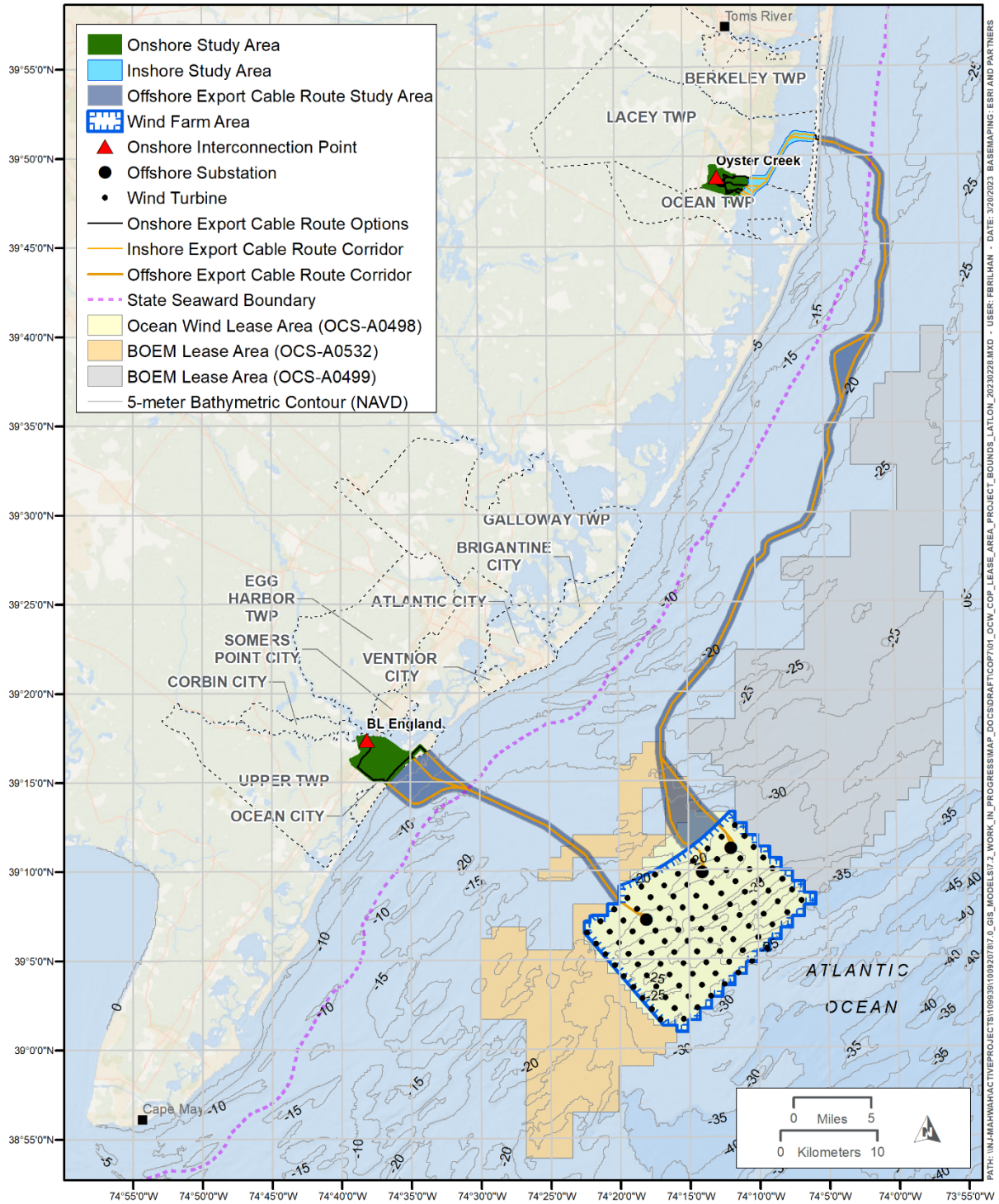

**Figure 4.1-1. Location plat and key Project components.**

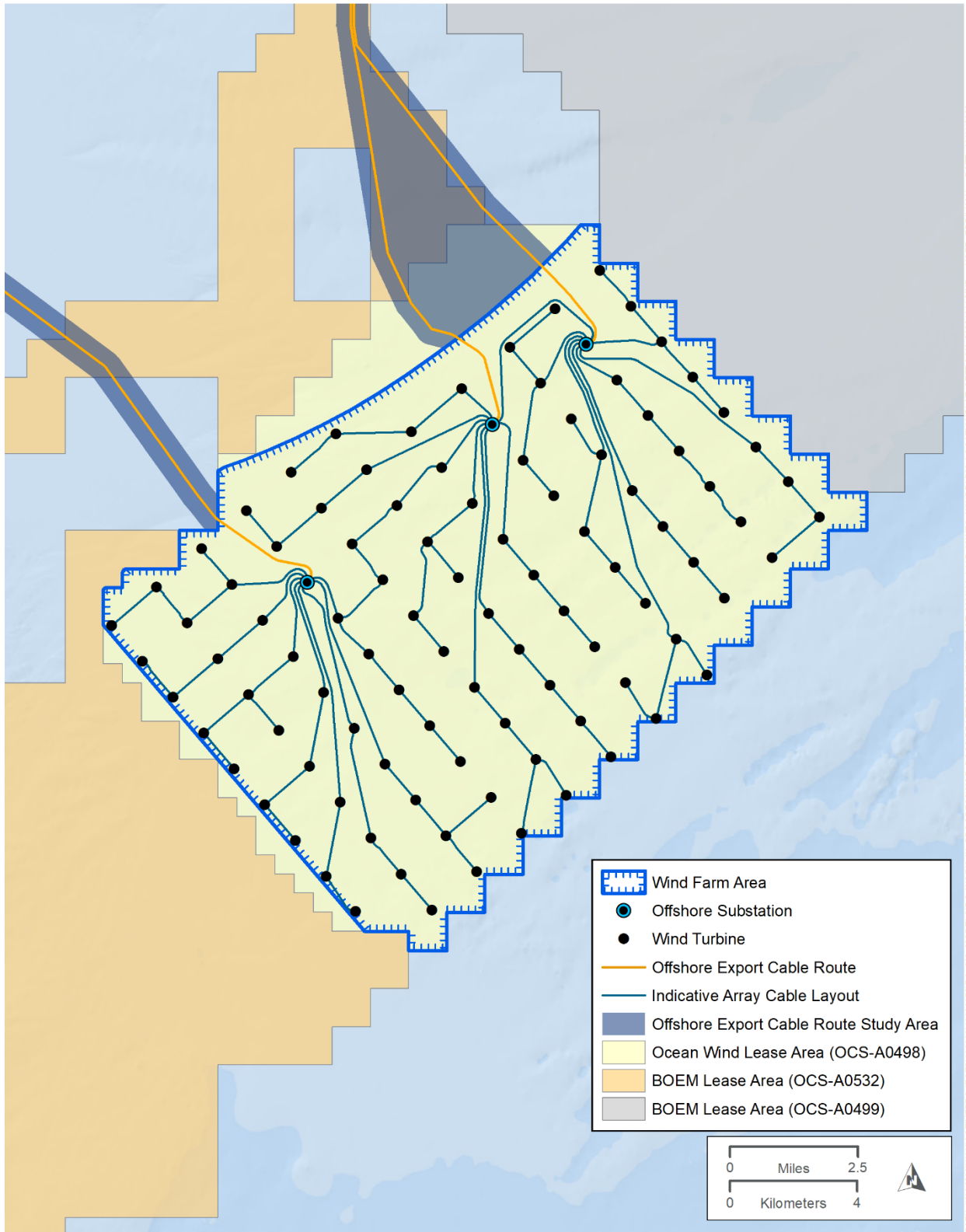

Figure 4.1-2. Indicative Location Plan.

## 4.2 Design Envelope Approach

BOEM has communicated its support of and preliminary recommendation that applicants voluntarily use the PDE (or design envelope) Approach in submission of COPs for offshore wind energy facilities in its *Draft Guidance Regarding the Use of a Project Design Envelope in a Construction and Operations Plan*, dated January 12, 2018 (BOEM 2018). “BOEM has concluded that the Project-specific information in a COP may be submitted in the form of a PDE, and that BOEM may approve a COP using a PDE approach, so long as the PDE description provides sufficient detail to allow BOEM to analyze its environmental impacts and conduct required consultations consistent with the requirements of NEPA and other relevant environmental statutes” (BOEM 2018).

BOEM indicated that use of a design envelope approach allows a permitting agency to review and analyze the maximum impacts that could occur from a range of designs and facilitates review of projects with phased development and assessment of cumulative impacts. The permitting agency can then assess potential impacts, focusing on design parameters that result in the greatest potential impact to a given resource (e.g., fish, benthic habitat, marine mammals) referred to in the BOEM guidance as “maximum design scenario”.

The design envelope approach has been taken throughout the COP to allow meaningful assessment of the Project to proceed, while still allowing reasonable flexibility for future Project design decisions.

## 4.3 Project Infrastructure Overview

The Project will include turbines and all infrastructure required to transmit power generated by the WTGs to two interconnection points with the PJM electric transmission system or power pool. Grid connections will be made at Oyster Creek and BL England.

The Project will have a maximum of 98 GE Haliade-X 12 MW turbines.

The electrical system is comprised of the cables and components required to step up/down the voltages at the WTGs and to transport the electricity generated from the Offshore Wind Farm to the interconnection points. The system consists of a low voltage side from the WTGs to the offshore substation and a high voltage side from the offshore substations to the interconnection points. Each offshore substation will collect the power transmitted from the WTGs and transform the voltage for transmission through the export cable to the onshore substations. Where environmentally and economically feasible, Ocean Wind is also considering an alternative design to transport the electricity generated from the Project to the interconnection point directly. The alternative system consists of only low voltage electrical components from WTG to interconnection point without the need for an offshore substation.

The onshore infrastructure will consist of a buried onshore AC export cable system, AC substations, and a buried connection to the existing electrical grid at each interconnection point. As noted, two interconnection points will be required, one at BL England and one at Oyster Creek. At Oyster Creek, Ocean Wind is considering an overhead grid connection option from the proposed onshore substation to the existing interconnection point as described in Section 6.2.1.3.

The Project will include the following components (**Figure 4.2-1**):

### Offshore Components

- Offshore wind turbines, foundations, and scour protection;
- Offshore substations with supporting substructure foundation, including scour protection where required;

- Array cable systems - linking the individual turbines together to offshore substations and including cable protection;
- Substation interconnector cables - linking the substations to each other; and
- Offshore export cable systems (includes offshore export cables and cable protection).

### Onshore Components

- Onshore export cable system - including TJBs, splice vaults/grounding link boxes, and fiber optic system, including manholes;
- Onshore substation(s); and
- Connection to the existing grid.

### Other Supporting Components

- Supervisory Control and Data Acquisition (SCADA) system;
- Temporary construction staging areas, including storage areas; and
- Permanent and temporary access roads.

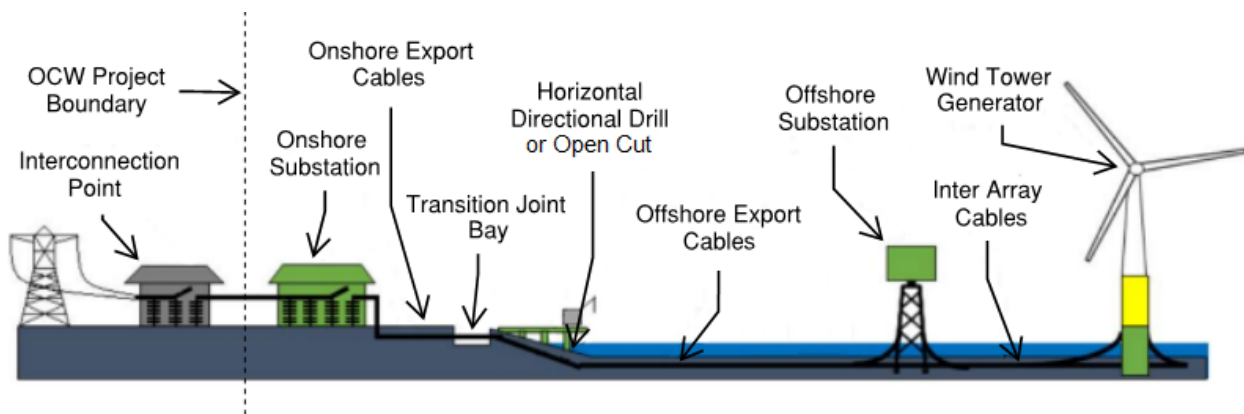

**Figure 4.2-1. Indicative key Project components.**

Power will be generated at the offshore wind turbines. Array cables will carry that power to offshore substations where the power will be collected and 'stepped up' to a higher voltage by transformers within the substation. The offshore substations will be connected to each other by substation interconnector cables to provide redundancy, providing the voltage is the same across the wind farm. If the voltage is not the same, then back links may be utilized to keep the turbines energized. Power will be transmitted to shore via offshore export cables.

The offshore substations will be connected to the onshore substations via offshore and onshore export cable systems. The offshore export cable will connect with the onshore export cable at the TJBs at the landfall location(s). The onshore export cables then transmit the power to the onshore substation where the voltage will be stepped up or down to match the grid voltage. The onshore substation constructed at Oyster Creek will receive power from offshore power at 275 kV or 220 kV that will be transformed to 230 kV, whereas the onshore substation constructed at BL England will receive power at 275 kV or 220 kV from offshore that will be interconnected to the grid at 138 kV. The power generated by the Project would be provided to the grid via a connection with the onshore substation(s). Appendix U includes conceptual plans and drawings for the Project.

It is likely that the Project components will be fabricated at a number of manufacturing sites across the U.S., Europe, or elsewhere. This will be determined based on the development of the supply chain in the U.S., as part of a competitive bidding process, and the completion by Ocean Wind of a Final Investment Decision. Some

components, including foundations and turbines, may be stockpiled at a port facility that serves as a construction base prior to delivery to the Wind Farm Area for installation. Other components may be delivered directly to the Wind Farm Area when required.

#### 4.4 Project Key Parameters

The key components of the Project are listed in **Table 4.4-1** along with the function of the component. The proposed activities include construction, operation and maintenance, and decommissioning of the proposed facilities.

**Table 4.4-1. Summary of PDE parameters.**

Project Parameter Details
<b>General (Layout and Project Size)</b>
<ul style="list-style-type: none"> <li>• Up to 98 WTGs</li> <li>• Project anticipated to be in service in late 2024 or early 2025</li> </ul>
<b>Foundations</b>
<ul style="list-style-type: none"> <li>• Monopile foundations with transition piece; or one-piece monopile/transition piece, where the transition piece is incorporated into the monopile</li> <li>• Foundation piles to be installed using a pile driving hammer</li> <li>• Scour protection around all foundations</li> </ul>
<b>Wind Turbine Generators (WTGs)</b>
<ul style="list-style-type: none"> <li>• Rotor diameter up to 788 ft (240 meters [m])</li> <li>• Hub height up to 512 ft (156 m) above MLLW</li> <li>• Upper blade tip height up to 906 ft (276 m) above MLLW</li> <li>• Lowest blade tip height 70.8 ft (22 m) above MLLW</li> </ul>
<b>Inter-Array Cables</b>
<ul style="list-style-type: none"> <li>• Target burial depth of 4 to 6 ft (1.2 to 1.8 m) depending on site conditions, navigation risk and third-party requirement (final burial depth dependent on cable burial risk assessment and coordination with agencies). Cables could be up to 170 kV</li> <li>• Preliminary layout available however final layout pending</li> <li>• Maximum total cable length is 190 mi (approximately 300 kilometers [km])</li> <li>• Cable lay, installation and burial: Activities may involve use of a jetting tool (both jet remotely operated vehicle (ROV) and/or jet sled), vertical injection, leveling, mechanical cutting, plowing (with or without jet-assistance), pre-trenching, controlled flow excavation (CFE)</li> </ul>
<b>Offshore Export Cables</b>
<ul style="list-style-type: none"> <li>• Up to three max. 275 kV export cables. Target burial depth of 4 to 6 ft (1.2 to 1.8 m) depending on site conditions, navigation risk and third-party requirements (final burial depth dependent on burial risk assessment and coordination with agencies)</li> <li>• Two export cable route corridors, Oyster Creek and BL England.</li> <li>• Maximum total cable length is 143 miles (230 km) for Oyster Creek and 32 miles (51 km) for BL England</li> <li>• Cable lay, installation and burial: Activities may involve use of a jetting tool (both jet ROV and/or jet sled), vertical injection, leveling, mechanical cutting, plowing (with or without jet-assistance), pre-trenching, backhoe dredger, CFE</li> </ul>

Project Parameter Details
<b>Offshore Substations</b>
<ul style="list-style-type: none"> <li>• Up to three offshore substations</li> <li>• Total structure height up to 296 ft (90 m) above MLLW</li> <li>• Maximum length and width of topside structure 295 ft (90 m; with ancillary facilities)</li> <li>• Offshore substations installed atop a modular support frame and monopile substructure or atop a piled jacket foundation substructure</li> <li>• Foundation piles to be installed using a pile driving hammer</li> <li>• Scour protection installed at foundation locations where required</li> </ul>
<b>Landfall for the Offshore Export Cable</b>
<ul style="list-style-type: none"> <li>• Open cut or trenchless (e.g., HDD, direct pipe, or auger bore) installation at landfall</li> <li>• Up to six cable ducts for landfall, if installed by trenchless technology</li> <li>• A reception pit (may be subsea pit, not yet finalized) would be required to be constructed at the exit end of the bore</li> <li>• Construction reception pit: excavator barge, land excavator mounted to a barge, sheet piling from barge used for intertidal cofferdams, swamp excavators</li> <li>• Sheet pile would be used at open cut landfall to stabilize the trench through the shoreline</li> </ul>
<b>Offshore Substations Interconnector Cable</b>
<ul style="list-style-type: none"> <li>• Max. 275 kV cables. Target burial depth 4 to 6 ft (1.2 to 1.8 m) depending on conditions (final burial depth dependent on burial risk assessment and coordination with agencies)</li> <li>• Potential layout available, however, not yet finalized</li> <li>• Maximum total cable length is 19 mi (approximately 30 km)</li> <li>• Cable lay, installation and burial: Activities may involve use of a jetting tool, vertical injection, pre-trenching, scar plow, trenching (including leveling, mechanical cutting), plowing, CFE</li> </ul>
<b>Onshore Export Cable</b>
<ul style="list-style-type: none"> <li>• Will connect with offshore cables at TJB and carry electricity to the onshore substation</li> <li>• Will be buried at a target burial depth of 4 ft (1.2 m) (this represents a target burial depth rather than a minimum or maximum)</li> <li>• Could require up to a 50 ft (15 m) wide construction corridor and up to a 30 ft (9 m) wide permanent easement for Oyster Creek and BL England cable corridors excluding landfall locations and cable splice locations to accommodate space for splice vaults, joint bays, and HDD. Permanent easements are expected to be larger at splice vaults and transition joint bay locations.</li> <li>• Up to eight export cables circuits will be required, with each cable circuit comprising up to three single cables. The cables will consist of copper or aluminum conductors wrapped with materials for insulation protection and sealing</li> <li>• TJBs, splice vaults/grounding link boxes, and fiber optic system, including manholes</li> </ul>
<b>Onshore Substations and Interconnector Cable</b>
<ul style="list-style-type: none"> <li>• Two onshore substations located in proximity to existing substations with associated infrastructure</li> <li>• Each onshore substation would require a permanent site (for Oyster Creek interconnection point up to 31.5 acres and for BL England up to 13 acres), including area for the substation equipment and buildings, energy storage and stormwater management and landscaping</li> <li>• During construction, up to an additional 3 acres would be required for temporary workspace</li> <li>• The main buildings within the substations would be up to 1,017 ft long, 492 ft wide and 82 ft tall (310 m long, 150 m wide and 25 m tall)</li> <li>• Secondary buildings may be used to house reactive compensation, transformers, filters, a control room and a site office. The external electrical equipment may include switchgear, busbars, transformers, high voltage (HV) reactors, static VAR compensator (SVC)/ static synchronous compensator (SVC/statcom), synchronous condensers, harmonic filters, and other auxiliary equipment. Lightning protection would include up to 35 lightning masts at Oyster Creek and up to 25 masts at BL England for a total height up to 98 ft (30 m).</li> <li>• Maximum height of overhead lines would be 115 ft (35 m).</li> <li>• Interconnector cable to existing sub-station</li> </ul>

Other supporting infrastructure includes metbuoys<sup>6</sup>, communication systems, temporary construction staging areas at each substation landfall, and on or near the onshore cable routes; permanent and temporary access roads; and a vessel support area.

#### 4.5 Schedule

**Figure 4.5-1** is the proposed schedule for the Project which is based on a Record of Decision in early Q3 2023. In addition to permitting, the design, resource monitoring, impact studies, construction, and operational activity schedules will be driven by the requirements of the OREC award and the ability of the Project to inject the generated power into the New Jersey grid.

- **Final Engineering Design.** Design activities are underway for each of the main packages of the Project. Design activities are expected to be complete within 24 months of the initiation of activities.
- **Procurement.** Ocean Wind is currently negotiating contracts (e.g., equipment supply and construction services).
- **Fabrication.** Fabrication of main components begins with the onshore part of the export cable and finishes with the final WTG delivered to the site ready for installation.

Construction will begin upon BOEM approval of the COP and other required regulatory approvals: currently anticipated in 2023. The Project is scheduled to deliver first power in late 2024 or early 2025.

---

<sup>6</sup> Ocean Wind will collect and analyze meteorological data, inclusive of wind speed and direction, waves and currents and information on other meteorological and metocean conditions within the Lease OCS-A 0498. See Appendix Y, Site Conditions Assessment.

# Ocean Wind 1 – Indicative Construction Schedule

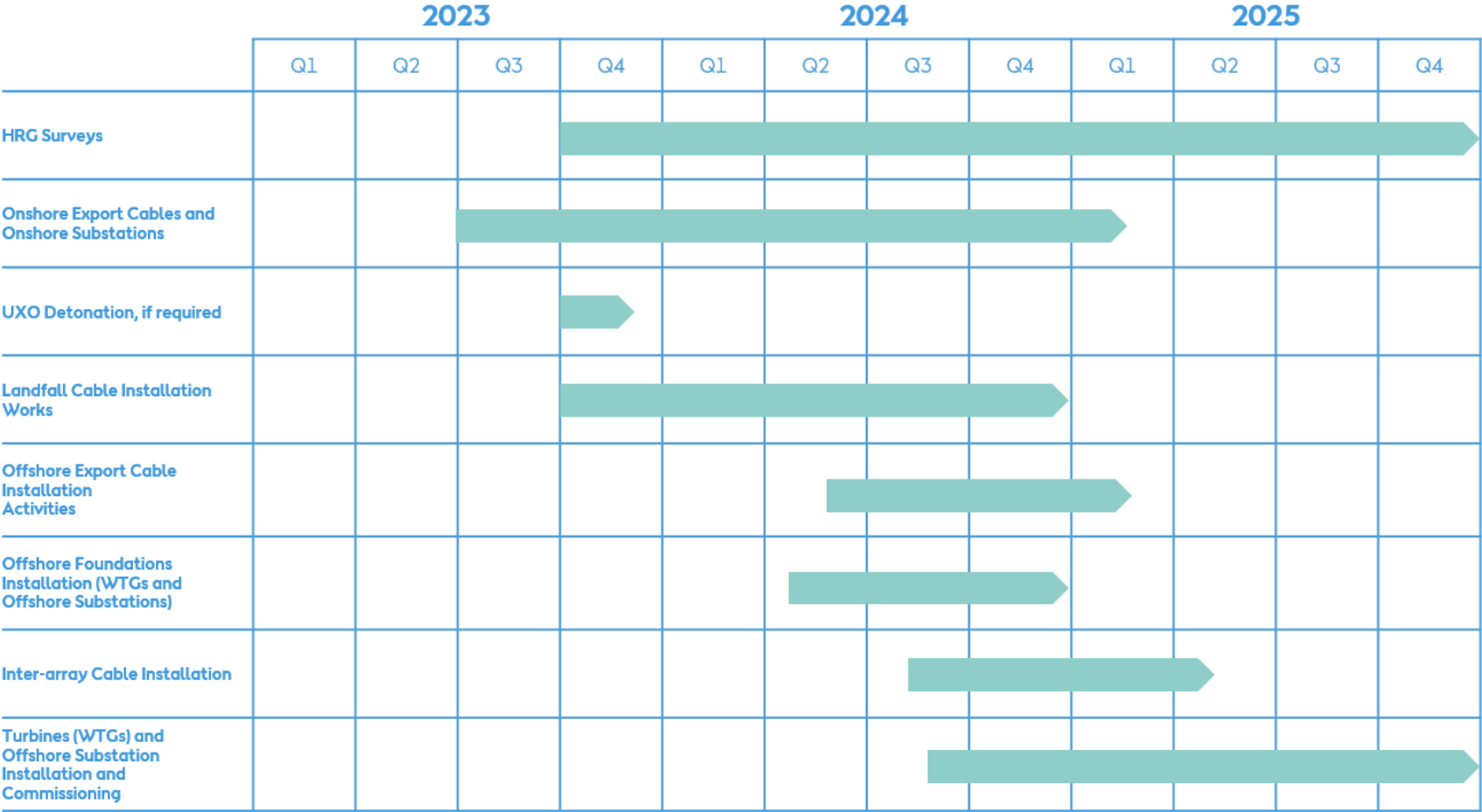

Figure 4.5-1. Indicative schedule.



## 4.6 Phased Development

The proposed Project will be in the northeastern portion of the original Lease Area (**Figure 1.1-1**). The Lease Area OCS-A 0498, after segregation (**Figure 4.1-1**), generally aligns with but is larger than the boundaries of the Wind Farm Area. As noted, the Project is expected to deliver renewable generation in late 2024 or early 2025. Future development of other parts of the original Lease Area, which has been designated a new lease number (OCS-A 0532), would represent a separate approval process.

## 5. Project Development, Route Planning, and Site Selection

BOEM published a Call for Information and Nominations - Commercial Leasing for Wind Power on the Outer Continental Shelf Offshore New Jersey in the Federal Register for public review in April 2011. The public comment period for the Call concluded on June 6, 2011. The New Jersey Wind Energy Area was separated into two lease areas (OCS-A 0498 and OCS-A 0499). An environmental review was conducted by BOEM for the sale of the wind leases. The notice of availability of an Environmental Assessment and Finding of No Significant Impact for commercial wind lease issuance was published in the February 3, 2012, Federal Register. On September 23, 2015, BOEM announced a Final Sale Notice for the commercial leases would occur on November 9, 2015. On April 14, 2016, Ocean Wind LLC submitted an application to assign 100 percent of the commercial lease OCS-A 0498. BOEM approved the assignment of all 160,480 acres of the original Lease Area OCS-A 0498 to Ocean Wind LLC on May 10, 2016. As noted in Section 4.1.2, on December 8, 2020 Ocean Wind requested that BOEM segregate Lease Area OCS-A 0498 into two similarly sized lease areas; the Wind Farm Area layout would remain unchanged. On March 26, 2021, BOEM approved this request.

The sections below provide a summary of the screening and siting of the Project.

### 5.1 Project Screening and Siting

During Project planning, Ocean Wind assessed several options for interconnection points, turbine layout, offshore and onshore substations, and export cable routes. These options were reviewed relative to Ocean Wind's purpose and need, schedule, and geographic requirements, as well as avoidance and minimization of potential impacts during construction, operation and maintenance, and decommissioning. The screening and siting of the Project is being conducted in three phases: 1) initial screening, 2) desktop study, windshield surveys, and stakeholder outreach, and 3) site specific surveys. The initial screening process involved the review and evaluation of various potential interconnection options, taking into consideration Ocean Wind's purpose and need and the criteria summarized below in **Table 5.1-1**.

Project screening and siting evaluations were conducted in the context of creating the PDE for the Project, to allow for reasonable flexibility in certain Project elements, while supporting Project review and approval processes being undertaken by BOEM under the terms of the Lease as well as other Federal, State, and local regulations.

**Table 5.1-1. Summary of criteria for Project screening and siting.**

Project Segment	Criteria
Wind Turbine Array	<ul style="list-style-type: none"> <li>• Clustered development for consolidated use of export cables and O&amp;M economies.</li> <li>• WTG location that minimizes visual impacts</li> <li>• Optimize WTG spacing - avoid spacing that limits options for future development and optimize wind resource and generation.</li> <li>• Avoid known submerged shipwrecks and other cultural resources.</li> <li>• Avoid known artificial reefs and unique habitats.</li> <li>• Avoid and minimize conflicts to existing users (e.g., fishermen and USCG operations)</li> </ul>
Interconnection Points	<ul style="list-style-type: none"> <li>• Availability of interconnection points (breaker positions) at the substation, or the capability to add interconnection points.</li> <li>• Capability of existing circuits connected to the substation that could accommodate the additional capacity of the Project.</li> <li>• Extent or the need for substation or system upgrades.</li> </ul>
Onshore Substations	<ul style="list-style-type: none"> <li>• Avoid or minimize impacts to environmental features (e.g., critical habitat, wetlands, cultural resources, existing contamination).</li> <li>• Proximity to the export cable route to minimize environmental impacts, neighborhood disruption (e.g., disturbances, interruptions, or changes), and costs associated with the cable connections to the point of interconnection.</li> <li>• Sufficient land available (a minimum of 6 acres).</li> <li>• Consistency with, and potential impacts on, adjacent land uses.</li> <li>• Constructability and cost.</li> <li>• Optimization of cable route lengths.</li> <li>• Availability of suitable landfall locations (i.e., those that minimize environmental impacts and are within 10 miles of the substation).</li> </ul>
Export Cable Landfalls	<ul style="list-style-type: none"> <li>• Avoid or minimize impacts to environmental features (e.g., critical habitat, shellfish lease areas, fish spawning areas, cultural resources, and existing contamination) by leveraging existing conditions (i.e., targeting areas that are closed to shellfish harvesting permanently).</li> <li>• Consistency with, and potential impacts on, adjacent land uses.</li> <li>• Constructability and cost.</li> <li>• Optimization of cable route lengths.</li> <li>• Availability of suitable landfall locations (i.e., those that minimize environmental impacts and are within 10 miles of the substation).</li> <li>• Use of existing ROWs when a landfall location was not adjacent to the water.</li> </ul>
Offshore Export Cable Route	<ul style="list-style-type: none"> <li>• Minimize extreme changes in slope and water depths.</li> <li>• Coarse grain sediments of sufficient depth to meet target cable burial depths while avoiding pockets of contaminated sediments and organic sediments.</li> <li>• Optimization of cable route lengths.</li> <li>• Avoid or limit crossing navigation channels and anchorage areas.</li> <li>• Avoid known submerged shipwrecks and other cultural resources.</li> <li>• Avoid mining and or dredge spoil areas.</li> <li>• Minimize number of infrastructure (e.g., utility) crossings.</li> <li>• Minimize impacts to aquatic communities and sensitive habitats.</li> <li>• Constructability and cost.</li> </ul>

Project Segment	Criteria
Onshore Export Cable Route	<ul style="list-style-type: none"> <li>Minimize extreme changes in slope.</li> <li>Property availability and State-owned and existing utility ROW.</li> <li>Avoid known Superfund Sites or sites designated as hazardous.</li> <li>Avoid known locations of historic or archaeological resources.</li> <li>Avoid or minimize number of infrastructure (e.g., roads, bridges, culverts) crossings.</li> <li>Minimize impacts to wetlands and floodplains.</li> <li>Minimize the overall length of the route to minimize impacts to terrestrial communities, wildlife species, and sensitive habitats.</li> <li>Minimize impacts to aesthetic resources.</li> <li>Minimize impacts to sensitive receptors such as hospitals, schools, and churches.</li> </ul>

After the initial statewide screening of interconnection points, taking into consideration the geographic, engineering, and interconnection criteria, a desktop analysis of the practicable interconnection options was conducted using geographical information system (GIS) data to identify opportunities and constraints. Constraints were defined as resources or conditions that could limit or prevent siting and routing. Constraints also included areas restricted by regulatory requirements or areas where impacts on resources would be difficult to mitigate. Opportunities were defined as resources or conditions that would facilitate Project development. In some instances, a resource could be both an opportunity and a constraint. For example, high and moderate shellfish areas are a constraint and were avoided to minimize impacts, while areas that are permanently closed to shellfishing were an opportunity as potential cable routes could be sited in these areas, therefore minimizing impacts to other areas that are not closed to shellfishing. The identification of opportunities and constraints were also based on technical guidelines (i.e., engineering and design requirements). These guidelines are specific to the Project and provide technical limitations related to the design, ROW requirements, and reliability.

#### 5.1.1 Interconnection Points

The selection of interconnection points was conducted based on a phased screening approach, which included an initial high-level assessment and then a desktop study and windshield survey. A total of 14 interconnection points were reviewed for the Project. During the initial screening, four were not carried forward. The remaining ten IPs were reviewed during the next stages of screening and ultimately three IPs were selected for the final stage of evaluation. A summary of the screening process is provided below.

During the initial screening of potential interconnection points, the following substation locations were identified in New Jersey, including: Monmouth, Colts Neck Township; Larrabee, Howell Township; Oyster Creek, Lacey Township; Cardiff, Egg Harbor Township; Dennis, Dennis Township; Salem, Lower Alloways Creek Township; Deepwater, Pennsville Township; New Freedom, Winslow Township; Deans, South Brunswick Township; Lewis, Egg Harbor Township; Manitou, Toms River Township; Higbee, Atlantic City; Ontario, Atlantic City; and BL England, Upper Township. During initial screening, the Dennis, Deepwater, Salem, and Monmouth interconnection points were eliminated from consideration and not carried forward into the desktop study phase due to engineering constraints, required upgrades, environmental and permitting constraints, and lack of available real estate to construct an onshore substation for connection. Specific details are as follows and further described in Section 5.2:

- Dennis: Substantial system wide upgrades would be required for the Project load.
- Deepwater: The route would require either high-voltage direct current (HVDC) cables or would need high-voltage alternating current (HVAC) cables with a booster station due to the distance from the substation to the Lease Area. In addition, offshore export cables would be installed within the Delaware River and Delaware State waters, and for an HVAC booster station to be effective, its siting

location would need to be near the mouth of the Delaware River. Therefore, HVDC, or HVAC cabling with a HVAC booster, would trigger additional State permitting requirements and coordination and would not minimize potential environmental impacts.

- Salem: The route would require either a HVDC cable, or HVAC cables with a booster station, due to the distance from the substation to the Lease Area. Offshore export cables would be installed within the Delaware River and Delaware State waters, and for an HVAC booster station to be effective, its siting location would need to be near the mouth of the Delaware River. Therefore, HVDC, or HVAC cabling with a HVAC booster, would trigger additional State permitting requirements and coordination and would not minimize potential environmental impacts. Additionally, while the nuclear power plants at Salem and Hope Creek are operational, extensive system-wide updates would also be needed to interconnect the Project load.
- Monmouth: The route would require either a HVDC cable, or HVAC cables and a booster station, due to the distance from the substation to the Lease Area and would not minimize potential environmental impacts.

During the next phase of screening, a desktop study and windshield surveys were conducted to further evaluate the existing opportunities and constraints for the remaining interconnection points: Oyster Creek, BL England, Cardiff, New Freedom, Manitou, Deans, Higbee, Ontario, Lewis, and Larrabee. Interconnection points were removed during this phase because real estate for the onshore substation was not currently available, and because of engineering constraints. Several of these interconnection alternatives would require longer onshore export cable routes, which would increase potential impacts to existing resources which is inconsistent with the criteria identified in **Table 5.1-1** for siting substations and export cable routes. The following interconnection points were eliminated for consideration as they do not meet the criteria identified in

**Table 5.1-1:**

- Cardiff: Routing to Cardiff was assessed crossing Lakes Bay and Absecon Bay through the wetlands with HDD. This was not carried forward due to space constraints and unfavorable ground conditions for HDD, and the proximity to developed areas adjacent to the bridges.
- New Freedom: Route would require either a HVDC system, or HVAC system with onshore located HVAC booster. The export cable would require a long and complicated onshore route through the New Jersey Pinelands, and to make a HVAC booster effective, it would need to be located onshore.
- Manitou: This interconnection point is to the north of Oyster Creek and the additional distance from the offshore lease area meant a HVAC booster would be required. It was not pursued over Oyster Creek which would not require a HVAC booster.
- Deans: Located much further north than any other interconnection point considered meant this option could only be built using a HVDC system. Deans would require a very long offshore export cable route, north along the Atlantic Coast, passing through both Sandy Hook Bay and Raritan Bay. No suitable onshore route was found to access the Deans substation.
- Lewis: Routing to Lewis would also require crossing the same bridges described for Cardiff and was discounted due to the same engineering complexity and environmental impact.
- Larabee: Route would require either a HVDC cable or would need to include a HVAC booster. There were very limited onshore cable route opportunities found for this option.

Based on discussions with utilities regarding substation upgrades, and on available technology and the results of the desktop study, the following interconnection point options were identified to carry forward for further project development:

- Oyster Creek
- BL England
- Higbee/ Ontario.

As project development progressed, Oyster Creek and BL England are the two interconnection points that were selected and are being carried forward in the COP. Although the Higbee and Ontario substations in Atlantic City are located closest to the Wind Farm Area, these substations are unable to accept the output of the Ocean Wind Project without major widespread onshore system upgrades. These additional upgrades did not fall within the Ocean Wind Project schedule and therefore, this interconnection point is not being further developed for this Project.

The Oyster Creek nuclear plant was retired during the Project development phase and is entering the decommissioning phase. Similarly, the BL England coal, oil, and diesel plant has retired in phases from 2014 to 2019. Utilizing the existing grid infrastructure used to formerly interconnect these plants provides the most efficient method of connecting offshore wind energy to the grid.

Consistent with the PDE approach, Ocean Wind is retaining options for landfall locations and, within the onshore study area, export cable route flexibility between landfall locations and interconnection point options (Oyster Creek and BL England) to allow for route refinement and optimization. Retaining options within a study area allows for flexibility as the Project design advances and is optimized (e.g., number of circuits and substation design developed), providing an opportunity to optimize technological advances, and utilize the supply chain which continues to evolve as it responds to the opportunities presented by the growing U.S. offshore wind market.

#### 5.1.2 Onshore and Offshore Export Cable Route Corridors

Once the terminal points, the Lease Area, and interconnection points were identified, further desktop study analysis was conducted to describe opportunities and constraints for the proposed Project's offshore and onshore export cables. Resource maps were developed using existing GIS resource data (no new data were generated for this study) and were based on the application of Project criteria (**Table 5.1-1**). Existing resources were reviewed and included bathymetry, geology, contaminated sediments, commercial and recreational fishing activities, navigation channels, anchorage areas, shipping activities, restricted areas, environmentally sensitive areas, cultural and historical resources, existing infrastructure, wetlands, and threatened and endangered species, as these resources are likely to impact the development, permitting, and construction of the Project.

The resource maps were used to identify and develop study areas, corridors and route options. Study areas were developed based on the PDE and developed to allow for flexibility for routing based on the site investigation surveys. Study areas were then further refined to develop export cable route corridors and indicative route options. In order to determine corridors, mapped resources were coded as an opportunity or a constraint. Corridors were selected to take advantage of opportunities and avoid constraints where possible. Route options were then developed based on resource opportunities and constraints in combination with engineering requirements. Buffers were established around constraints so they could be avoided where possible. Candidate routes were identified to take advantage of opportunities, including State owned and existing ROW, and to avoid constraints such as artificial reefs and cultural resources. Routes that crossed railroad ROWs were eliminated based on engineering and construction challenges; and routes that crossed inlets, wildlife refuges, and wildlife management areas were eliminated due to sensitive habitats and permitting requirements. Project study areas and indicative route options are shown in **Figures 1.1-1** and **4.1-2** and **Figures 5.1-1** through **5.1-3** and summarized below. In early 2022, Ocean Wind expanded its review of potential landfall alternatives associated with the Lighthouse Drive and Bay Parkway cable route options as well as cable route options to enter the Oyster Creek substation. Those additional routes are incorporated into **Figures 5.1-1** and **5.1-2**.



**Figure 5.1-1. Project location - Oyster Creek.**

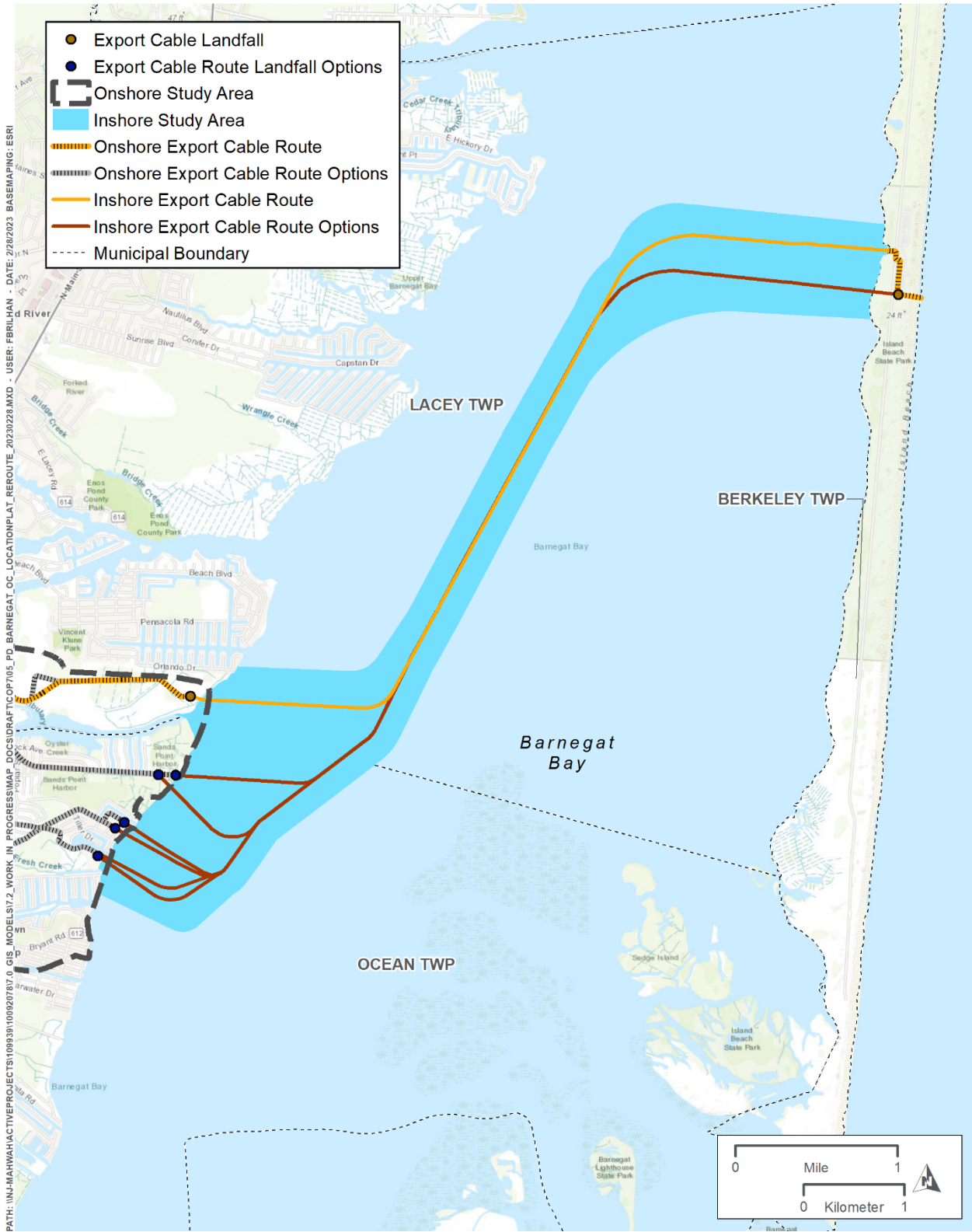

Figure 5.1-2. Project location - Barnegat Bay/Oyster Creek.



Figure 5.1-3. Project location - BL England.



Ocean Wind has not selected a single option for the onshore and offshore export cable routes, but rather, using the PDE approach, retains several options to allow for review of the Project through site specific field surveys, site investigations, agency coordination, and stakeholder outreach. Further, retaining options within a study area allows for greater flexibility as the Project design advances (e.g., number of circuits), as technological advances occur, and as supply chain characteristics evolve in the U.S. offshore wind market.

Section 4 provides a detailed description of the Project and associated PDE and Section 6 provides information regarding the location, installation, operation, and decommissioning of the facilities. Volume II describes the potential impact-producing factors resulting from the construction, operation and maintenance, and decommissioning of the Project, an analysis of potential impacts to the resources associated with the PDE and the proposed mitigation measures for these impacts.

For the COP, two offshore export cable route corridors were identified. These corridors were developed to avoid sensitive resources and hazards and will be able to accommodate modifications to routing based on site specific HRG&G surveys as well as anticipated activities during construction, operation and maintenance and decommissioning. The beaches of Ocean City are in the USACE Beach Nourishment Program, which requires a minimum cable burial depth below the active beach template (which starts at approximately -30 feet North American Vertical Datum [NAVD]) to avoid the cable being impacted by beach erosion. Therefore, trenchless technology is under consideration at this beach for the offshore cable to reach the TJB.

- Oyster Creek:
  - Offshore Export Cable Route Corridor: The corridor begins within the Wind Farm Area and proceeds northwest to the Atlantic Ocean side of Island Beach State Park (IBSP).
  - Inshore Export Cable Route Corridor (Figure 5.1-2):
    - Inshore Export Cable Route (Prior Channel Route) - The corridor will diverge and continue north within parking lots, then northwest under Shore Road, and then west into the Bay side of IBSP on the west side of a maintenance area off of Shore Road. The route will continue via open cut into Barnegat Bay within a prior channel that was previously dredged, then southwest to make landfall near Oyster Creek in Lacey Township.
    - Inshore Export Cable Route Option - The corridor would exit into the Bay from the west side of IBSP (Berkeley Township), directly across from the Atlantic Ocean landfall, and would cross Barnegat Bay southwest, to make landfall near the Oyster Creek substation on the west side of Barnegat Bay.
- BL England:
  - Offshore Export Cable Route Corridor: The corridor begins within the Wind Farm Area and proceeds west to make landfall in Ocean City, New Jersey.

Ocean Wind has identified indicative onshore cable route options that are representative of the potential existing conditions and impacts within the onshore study area for Oyster Creek and BL England.

- Oyster Creek:
  - Onshore Export Cable Route - A straightened (shorter) route would make landfall and travel west, taking advantage of previously disturbed areas where possible along the Holtec property. The crossing of Oyster Creek and Route 9 would be conducted using trenchless technology methods to an existing private road, and the route would continue within the existing private road to the substation parcel.<sup>7</sup>

---

<sup>7</sup> This route was developed as Project design has been refined. The updates are within the onshore study area and potential impacts within the extent of environmental analysis in the COP.

- Onshore Export Cable Route Option - A route developed earlier would make landfall and travel west across undeveloped land, taking advantage of previously disturbed areas where possible, before following abandoned roadways associated with the existing confined disposal facility and Holtec property. In order to minimize potential impacts to wetlands and vegetation, the route would follow existing berms, paths and trails where practical. The route would then follow existing roadways State Route 9 and a private road to the substation parcel. The crossing of Oyster Creek could be conducted using trenchless technology methods or by an independent utility bridge (existing Route 9 bridge or new construction).
- Marina Alternative - The route starts at a landfall within the Lighthouse Marina; continues northwest within the marina property to Southwind Drive. From Southwest Drive the route would stay within public ROWs and previously disturbed areas to Letts Landing Road; continues west within Letts Landing Road to Main Street; continues north within Main Street to the west side of Route 9. The route would cross Route 9 on private land and then northwest using trenchless technology into the substation.
- Nautilus Drive Alternative - The route starts at a landfall within Nautilus Drive and follows the public ROW to Lighthouse Drive; continues southwest on Lighthouse Drive to Main Street; continues northwest within Main Street to Route 9; continues north on Route 9; the route then crosses Route 9, the crosses within private land and then northwest using trenchless technology into the substation.
- Bay Parkway Alternative –The route starts at a landfall within Bay Parkway; continues within Bay Parkway to Route 9; continues south on Route 9, continues west within private land. The route continues north along an old access road; continues northwest using trenchless technology to the substation access road and finally continues along the substation access road to the substation.
- Additional Onshore Export Cable Route Options -The Bay Parkway and Lighthouse Road routes in Ocean Township are examples of an all-road route. Construction would be within existing County ROW and previously disturbed areas.
- BL England:
  - Construction on 5<sup>th</sup> Street, 13<sup>th</sup> Street or 35<sup>th</sup> Street in Ocean City would be within existing ROW of local streets.
  - Using the 5<sup>th</sup> and 13<sup>th</sup> Street routes, the cable would then be within West Avenue to 35<sup>th</sup> Street.
  - After making landfall at 35<sup>th</sup> Street in Ocean City and travelling on local roads west, the cable would cross Peck Bay (undeveloped area) at Roosevelt Boulevard Bridge via trenchless technology methods and then the cable would continue on existing County road ROW of Roosevelt Blvd turning north on State Rte. 9 to the potential substation property at the decommissioned BL England Generating Station.

### 5.1.3 Landfalls

Several landfall options were identified within each study area during the desktop study. These landfall sites were then reviewed to see if they met design and construction criteria. If the landfall did not meet those criteria it was removed from further evaluation. The remaining landfalls were then screened based on real estate availability, windshield surveys, and meetings with the local municipalities. The following landfall options have been identified, and based on preliminary engineering, are suitable for cable installation. Ocean Wind plans to use trenchless technology, where feasible, to make landfall at beaches under the USACE Beach Nourishment Program. Site specific topographic and geotechnical surveys will be conducted to further refine landfall options within the study areas.

- Oyster Creek
  - The IBSP landfall is located within an auxiliary parking lot of Swimming Area #2. The area is comprised of paved areas.
  - The Holtec property landfall is located at the shore of Barnegat Bay, and targets previously disturbed areas where possible.
  - The Bay Parkway landfall is located at the end of Bay Parkway within an existing road ROW.
  - The Lighthouse Drive landfall is located at the end of Lighthouse Drive on private property and then utilizes existing road ROW
  - Nautilus Drive landfall is located at the end of Nautilus Drive within an existing road ROW.
  - The Marina landfall is located within the Holiday Harbor Marina within previously disturbed graveled areas.
  
- BL England
  - Ocean City: The 5<sup>th</sup> street landfall is located in a municipal parking lot that is paved.
  - Ocean City: The 13<sup>th</sup> Street landfall is located within the local roadway
  - Ocean City: The 35<sup>th</sup> Street landfall is located within ROW of the local roadway
  - Upper Township: The Roosevelt Boulevard landfall is achieved via trenchless technology under Peck Bay landing on an access road south of the Roosevelt Blvd Bridge.

As noted, Ocean Wind has not selected a single option for the landfalls, but rather, consistent with the PDE approach, retains several options to allow for review of the Project through site specific field surveys, site investigations, agency coordination, and stakeholder outreach. Further, retaining options within a study area allows for greater flexibility as the Project design advances (e.g., number of circuits), as technological advances occur, and as supply chain characteristics evolve in the U.S. offshore wind market. As discussed in Section 5.1.2, further discussion of the Project and associated PDE, including information regarding the location, installation, operation, and decommissioning of the facilities, occurs in Sections 4 and 6, and Volume II of the COP describes the potential impact-producing factors resulting from the construction, operation and maintenance, and decommissioning of the Project, an analysis of potential impacts to the resources associated with the PDE, and the proposed mitigation measures for these impacts.

#### 5.1.4 Onshore Substations

Potential onshore substation parcel options are identified in **Figures 5.1-2** and **5.1-3** for Oyster Creek and BL England interconnection points. To minimize potential impacts, the parcels that are being considered are in proximity to the interconnection point and have been previously developed, maintained, or disturbed. Final selection of the onshore substation will be based on real estate negotiations and coordination with municipalities. However, for the purposes of the COP, onshore existing conditions and impacts are described within the study area using indicative substation layout and typical property conditions.

For the BL England onshore substation, Ocean Wind originally planned to use a portion of the former BL England Generating Station property that was previously used as a golf course (BL England Golf Course; greenfield) as shown in the initial COP iterations and BOEM's Draft Environmental Impact Statement for the Project. In response to comments from Upper Township's town council received during the Draft EIS Public Hearing on July 14, 2022 and in an effort to reduce impacts on areas zoned for recreation and park use as per the Township of Upper Redevelopment Plan adopted by the Township Governing Body on January 25, 2021, Ocean Wind has moved its preferred substation location to an adjacent portion of the same property which formerly housed elements of the BL England Generating Station. These elements of the former BL England Generating Station, including coal storage, and waste-water storage tanks, were demolished, and the site remediated, and the area was subsequently made available to Ocean Wind for its substation development that

would allow for a reduction in impacts. The recently remediated site offers little habitat due to recent disturbance from demolition and remediation and what is present is low quality habitat as compared to the greenfield site on the golf course. In addition, multiple wetlands were delineated within the golf course site that would have been permanently filled as a result of construction of the substation. While the onshore export cable extension may impact some of these wetlands, the cable would be buried below ground and any wetland impacts would be temporary. The coal storage brownfield location is devoid of wetlands, and as such permanent wetland impacts associated with the substation will be avoided. There are tidal wetlands along the western boundary of the new substation site, outside of a concrete wall. There may be a need to temporarily impact wetlands at the western boundary of the coal storage brownfield location in relation to the existing concrete wall and there will be a small area of permanent impact to the tidal wetland associated with the direct footprint of a proposed stormwater outfall. For these reasons, the BL England Golf Course greenfield option for the BLE substation location is no longer being carried forward.

#### 5.1.5 Project Boundary

##### *5.1.5.1 Project Boundary Options Considered*

As shown in **Figure 5.1-4**, multiple project boundary limits were considered for the Project in conjunction with the Project purpose and need (Section 3) and the Project screening and siting criteria included in **Table 5.1-1**. Options were developed and considered as the design evolved and from feedback from agencies and stakeholders.

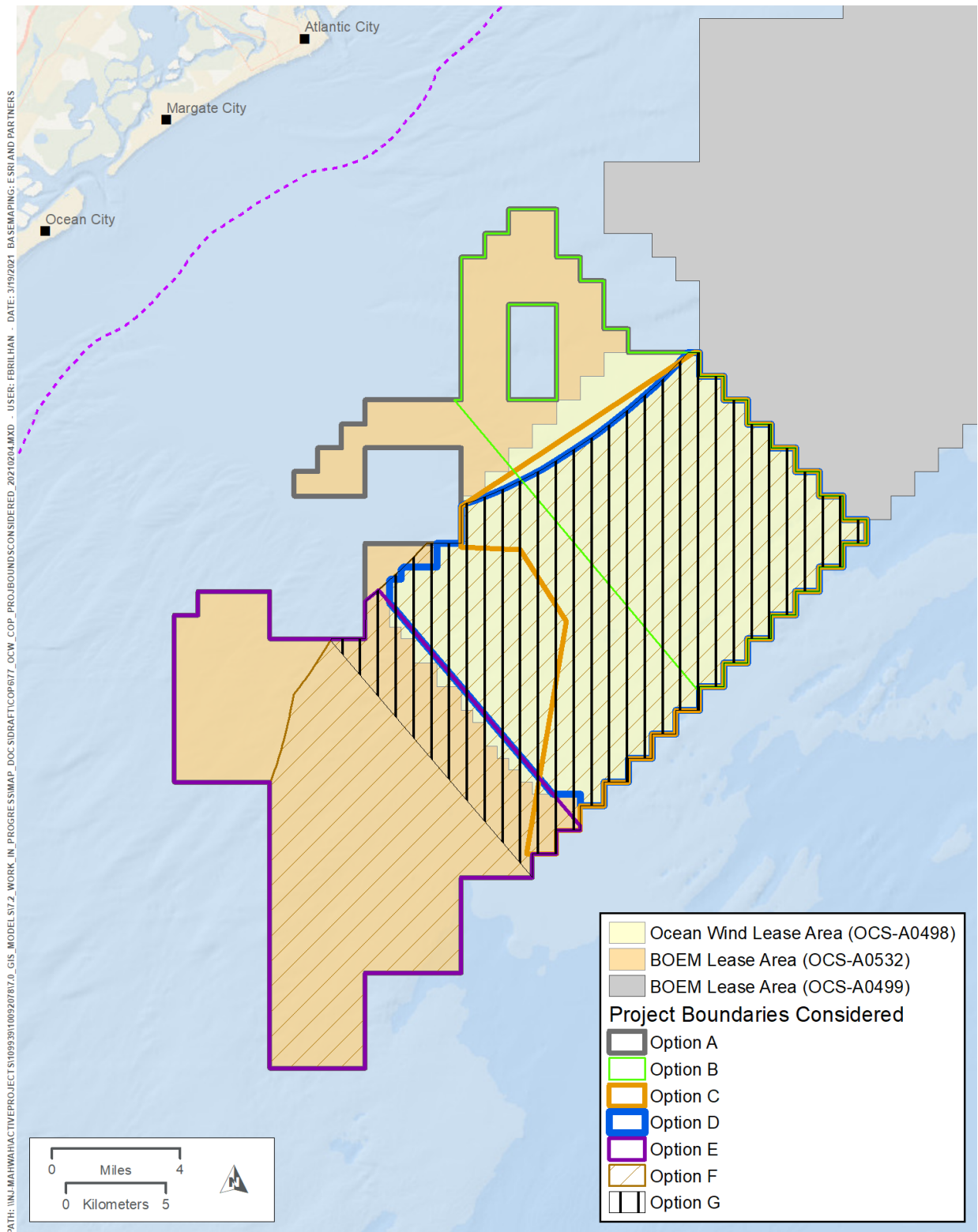

**Figure 5.1-4. Project boundaries considered for the Project.**

#### 5.1.5.1.1 Option A

Option A considered using the entire original Lease Area as the boundary for the Project. Use of the original Lease Area for the Project boundary would not be consistent with the siting criteria for clustered development to allow for consolidated use of export cables and O&M economies and optimization of cable route lengths. Not meeting these criteria would affect constructability and cost.

Use of the entire original Lease Area for this Project would limit options for future development and optimization of wind resources and generation within the Lease Area. This would not be consistent with siting criteria for optimizing wind resource and generation, with New Jersey's goals for renewable energy, or with the purpose and need for the Project. Therefore, this option was not carried forward for further consideration.

#### 5.1.5.1.2 Option B

Option B considered using the northernmost portion of the original Lease Area for the Project, building the WTG array at the closest point to shore, and not having any corridors or regular spacing of turbines. Based on review of initial visual simulations for the Project as well as comments from stakeholders, Option B was not carried forward for further consideration as it did not minimize visual impacts or accommodate usage of the Lease Area by transiting vessels.

#### 5.1.5.1.3 Option C

Option C considered using the northern portion of the original Lease Area and siting facilities a minimum of 13 nm from shore to minimize visual impacts. The boundary from Option B was used as a starting point and modified to eliminate the area closer than 13 nm to shore. This left inadequate area to site facilities to maximize generation, so the boundary was extended in an irregular shape to the southwest with greater extension farthest from shore.

Option C supported a non-orthogonal array layout (changes in array layout are discussed further in Section 5.1.6). Non-orthogonal array layouts optimize WTG spacing by positioning WTGs to minimize wake effects and maximize energy production while minimizing array cable lengths to the extent practicable. Ocean Wind received feedback from Federal and State regulatory agencies and from the maritime community that the non-orthogonal array layout presented challenges for fishing vessels and USCG operations. As a result, the non-orthogonal array layout was dismissed from further evaluation.

When combined with a regularly spaced layout rather than non-orthogonal array layout, Option C's irregularly shaped extension to the south and west would not be consistent with the siting criteria for clustered development to allow for consolidated use of export cables and O&M economies, and optimization of cable route lengths. Not meeting these would affect constructability and cost. Therefore, Option C was not carried forward for further consideration.

#### 5.1.5.1.4 Option D

Option D considered using the northern portion of the original Lease Area and siting facilities a minimum of 13 nm from shore to minimize visual impacts. The boundary from Option B was used as a starting point and modified to eliminate the area closer than 13 nm to shore. This left inadequate area to accommodate facilities, so the boundary was extended to the southwest in a generally rectangular shape. This shape was suited to line spaced layouts, which are discussed further in Section 5.1.6.

Option D Alternative (1,500 m Separation Distance Option) – This alternative modifies Option D in response to the USCG's request for a setback from the shared border between the Ocean Wind and Atlantic Shores Projects (**Figure 5.1-5**). In order to facilitate marine traffic, navigation safety, as well as USCG search and rescue operations between Lease Area OCS-A 0498 and Lease Area OCS-A 0499, Ocean Wind and Atlantic

Shores Offshore Wind, LLC (Atlantic Shores) identified a 1,500-meter buffer corridor between WTGs of the two Lease Areas in which no surface structures would be created as an alternative for evaluation under BOEM's Alternative C scenarios. Previously, Ocean Wind and Atlantic Shores evaluated a 750-meter setback area from the shared Lease Area boundary, however, as indicated by the USCG, the buffer corridor does not need to be measured from the centerline, but instead from individual turbines in the respective lease areas to enable a total 1,500 m separation corridor.

To achieve the buffer corridor, Ocean Wind would relocate the northern most row (A02-A09) of turbines to 1 nautical mile from the second most northern row (B02-B09) (**Figure 5.1-5**). This action would also align row A's turbine spacing to be consistent with the rest of the rows within the Ocean Wind Wind Farm Area. In relocating turbines, Ocean Wind will create the necessary space to achieve the 1,500-meter corridor between the lease areas. Therefore, the Option D Alternative is carried forward and considered in this COP and represented in **Figures 4.1-1** and **4.1-2**.

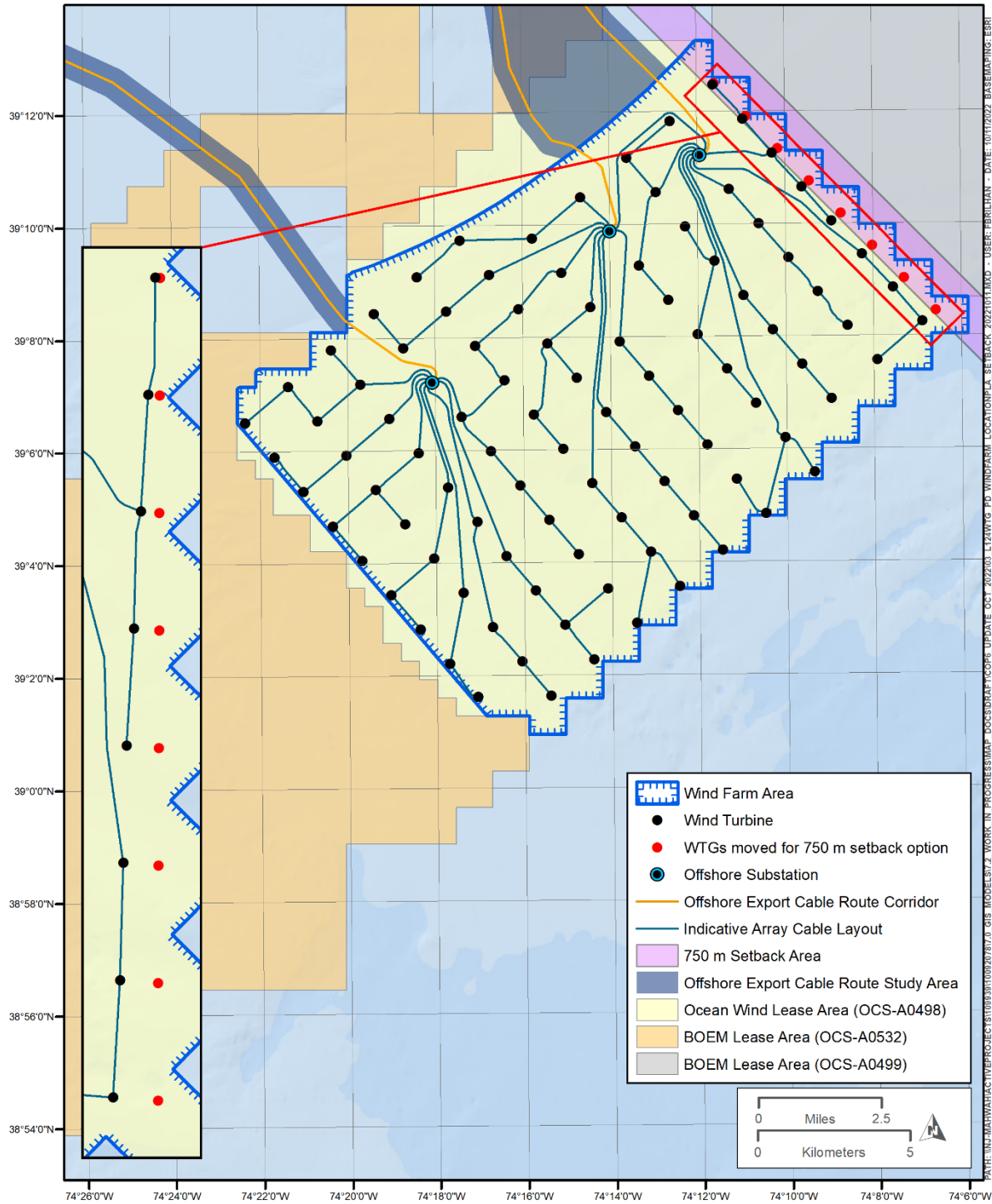

Figure 5.1-5. Indicative Location Plan - 1,500 m separation option.



#### 5.1.5.1.5 Option E

Option E considered using the southernmost portion of the original Lease Area for the Project. As shown on **Figure 1.1-1**, the southern portion of the original Lease Area is farthest from the Interconnection Points and would require longer cable routes and potentially additional infrastructure, such as AC booster stations to prevent losses along the cable routes. Longer routes and additional infrastructure would potentially result in greater impacts and greater cost. Option E is inconsistent with the siting criteria for optimizing route lengths, minimizing environmental impacts, and constructability and cost criteria. Option E was not carried forward for further consideration.

#### 5.1.5.1.6 Option F

Option F considered the original Lease Area beginning 13 nm from shore. Similar to Option A, locating Project components throughout the Lease Area beginning 13 nm from shore would affect a larger area and would increase impacts during construction, operation and maintenance, and decommissioning. This option would not be consistent with the siting criteria for clustered development to allow for consolidated use of export cables and O&M economies and optimization of cable route lengths. Not meeting these criteria would affect constructability and cost.

Use of the entire original Lease Area starting 13 nm for this Project would limit options for future development and optimization of wind resources and generation within the original Lease Area. This would not be consistent with siting criteria for optimizing wind resource and generation, with New Jersey's goals for renewable energy, or with the purpose and need for the Project. Therefore, this option was not carried forward for further consideration.

#### 5.1.5.1.7 Option G

Option G considered an expanded version of Option D as the Project boundary. The boundary is similar to Option D but extends further southwest. Similar to Options A and F, this would involve a larger area, which would increase environmental impacts. Therefore, this option was not carried forward for further consideration.

#### 5.1.5.2 Project Boundary Carried Forward

Ocean Wind selected the Option D Alternative to carry forward for further design of the Project because the Option D Alternative is consistent with siting criteria listed in **Table 5.1-1**. The northern portion of the Lease Area is closest to the interconnection points with the existing grid. Proximity to the grid connections minimizes export cable route lengths and array cable lengths, eliminates the need for additional infrastructure (such as AC boosters that would be required for longer cable routes), minimizes environmental impacts during construction, operation and maintenance and decommissioning and minimizes costs. Siting the project within the northern portion of the original Lease Area is consistent with optimizing cable route length, minimizing environmental impacts, and constructability and cost siting criteria. The Option D Alternative is located a minimum of 13 nm from shore to minimize visual impacts, consistent with visual impact siting criteria as well as minimizing impacts to birds by avoiding the migratory pathway. The Option D Alternative boundary also minimize impacts to navigation and commercial fishing use of the Lease Area (Appendix M). And lastly, Ocean Wind and Atlantic Shores have agreed to the separation layout specified by the Option D Alternative, in collaboration with the Coast Guard, in the interest of facilitating navigation safety and effective search and rescue; the Option D Alternative would significantly enhance navigational safety by providing vessel traffic a clear and consistent buffer between the two lease areas (Lease Area OCS-A 0498 and Lease Area OCS-A 0499, respectively).

As mentioned above in Section 4.1.2, BOEM segregated portions of Lease Area OCS-A 0498 into a new lease area. Based on this change, Ocean Wind reviewed the Project Boundaries discussed above. The Option D

Alternative best aligns with siting criteria, and while minimizing impacts, remains the Project boundary carried forward in this COP.

#### 5.1.6 Wind Farm Area

As shown in **Figure 4.1-1**, the Wind Farm Area will include the WTGs, offshore substations, interconnector cables, part of the offshore export cables, and array cables. Final layouts of these components will be based on the results of the phased site investigation HRG&G surveys. Ocean Wind evaluated a number of WTG and offshore substation layouts for the Project. Layouts were reviewed based on maximizing the use of the wind resource and energy production while minimizing visibility of the Project and potential impacts to resources and conflicts with navigation and commercial and recreational use of the Lease Area.

The two WTG layouts that were considered are the Non-Orthogonal Array and the southeast-northwest Array. The Non-Orthogonal Array is an “optimized” array format commonly used in European developments. In this type of array, the WTGs are positioned to minimize wake effects such that energy production is maximized. As a result, the spacing appears to be randomized. The East-West Array is comprised of rows of WTGs oriented east to west. The WTGs are positioned along the rows as necessary to maintain optimization and minimize wake loss.

The Non-Orthogonal Array offered several advantages for the Project. The number of WTGs and pattern of optimization allowed Ocean Wind to reduce wake loss and maximize efficiency of capturing wind resource, producing energy more effectively than the southeast-northwest array. Typically, this optimization significantly decreases the cost of energy production, resulting in significant savings for local ratepayers. However, through engagement with Federal and State regulatory agencies and the maritime community, Ocean Wind received feedback that the Non-Orthogonal Array had disadvantages, including potential challenges for fishing vessels and USCG operations. For this reason, the Non-Orthogonal Array was dismissed from further evaluation for this Project (**Table 5.2-1**).

Based on this feedback, the Project array was redesigned in the southeast-northwest orientation. Although the modification of the layout reduces the overall efficiency and energy production of the Project, it satisfies the concerns of the regulatory agencies and the maritime community, and still allows for commercially feasible development of the Lease Area.

Ocean Wind sought to optimize capacity, navigation, and schedule, while accommodating commercial fishing needs, minimizing cable and turbine footprint, and preserving the original lease area for future development in combination with the selected Project boundary. Therefore, a spacing of 1 nm by 0.8 nm between WTGs was selected.

Ocean Wind would deploy up to 98 turbines. This layout is reflected in the COP and is considered indicative, as geophysical and geotechnical surveys are still underway. In order to minimize potential impacts to navigation and viewshed, the offshore substations are sited within the Wind Farm Area. Only after this extensive analysis was completed, the Option D Alternative carried forward, was lease segregation initiated to provide for potential future development by Orsted.

## 5.2 Design Alternatives Reviewed and Not Carried Forward

During the routing and siting process described above, Ocean Wind considered multiple design alternatives that were not carried forward for consideration in the COP. Design alternatives were either eliminated at the desktop stage, or based on windshield surveys and coordination with agencies, municipalities, and property owners. A summary of these is provided below in **Table 5.2-1**.

**Table 5.2-1. Design alternatives reviewed and not carried forward**

Design Alternative	Reason Not Carried Forward
<b>Technology</b>	
HVDC	<ul style="list-style-type: none"> <li>• HVDC is not economically or technically desirable for this Project as it is typically used for transmitting energy over longer distances than the Ocean Wind Project.</li> <li>• HVDC cable supply is constrained and use of this technology would not meet the Project schedule.</li> <li>• HVDC cable would require the construction of converter stations which would increase potential environmental impacts.</li> </ul>
AC Boosters	<ul style="list-style-type: none"> <li>• Not needed as interconnection points are close.</li> <li>• Additional impacts associated with siting additional facilities either offshore or onshore.</li> </ul>
Monopod Suction Caisson Foundations	<ul style="list-style-type: none"> <li>• Site conditions including water depths and geology are not suitable.</li> <li>• Requires a larger footprint which would result in greater impacts to the seabed.</li> <li>• Supply chain availability would not meet Project schedule.</li> <li>• Supply chain is not mature enough with these technologies to make these options cost effective.</li> </ul>
Suction Caisson Jacket Foundations	<ul style="list-style-type: none"> <li>• Site conditions including water depths and geology are not suitable.</li> <li>• Requires a larger footprint which would result in greater impacts to the seabed.</li> <li>• Supply chain availability would not meet Project schedule.</li> <li>• Supply chain is not mature enough with these technologies to make these options cost effective.</li> </ul>
Piled Jacket Turbine Foundations	<ul style="list-style-type: none"> <li>• Water depths at site are shallower than typical water depths of piled jacket turbines.</li> <li>• Additional bottom impacts anticipated.</li> </ul>
Gravity Base Turbine and Offshore Substation Foundations	<ul style="list-style-type: none"> <li>• Technology has not been fully developed or assessed in terms of technical feasibility, supply chain capability, and cost.</li> <li>• Orsted has not implemented this substructure technology within its existing portfolio and the timeline for such development cannot be delivered in time to support the Project.</li> <li>• Manufacturing places not available in the area.</li> <li>• Larger footprint and area of disturbance.</li> </ul>
Floating Platforms	<ul style="list-style-type: none"> <li>• Technology has not been fully developed or tested.</li> <li>• Technology is appropriate only for projects in deeper water depths than found in the Project boundary.</li> </ul>
<b>Project Boundary and Wind Farm Area</b>	
Non-Orthogonal Array Layout	<ul style="list-style-type: none"> <li>• Impacts to navigation, other marine uses, commercial and recreational fishing would be greater.</li> </ul>
Offshore Substations Location Outside of the Lease Area	<ul style="list-style-type: none"> <li>• Impacts to navigation, other marine uses, commercial and recreational fishing would be greater.</li> <li>• Impacts to viewshed would be greater.</li> </ul>
Project Boundary Option A	<ul style="list-style-type: none"> <li>• Impacts to marine environment would be greater.</li> <li>• Not consistent with siting criteria for clustered development to allow for consolidated use of export cables and O&amp;M economies and optimization of cable route lengths. Not meeting these criteria would affect constructability and cost.</li> </ul>
Project Boundary Option B	<ul style="list-style-type: none"> <li>• Not consistent with siting criteria</li> <li>• Did not minimize visual impacts</li> <li>• Presented challenges for fishing vessels and USCG operations</li> </ul>
Project Boundary Option C	<ul style="list-style-type: none"> <li>• Presented challenges for fishing vessels and USCG operations</li> <li>• Not consistent with the siting criteria for clustered development to allow for consolidated use of export cables and O&amp;M economies, and optimization of cable route lengths.</li> </ul>
Project Boundary Option E	<ul style="list-style-type: none"> <li>• Impacts to marine environment would be greater.</li> </ul>

Design Alternative	Reason Not Carried Forward
	<ul style="list-style-type: none"> <li>Not consistent with siting criteria for clustered development to allow for consolidated use of export cables and O&amp;M economies and optimization of cable route lengths. Not meeting these criteria would affect constructability and cost.</li> </ul>
Project Boundary Option F	<ul style="list-style-type: none"> <li>Impacts to marine environment would be greater.</li> <li>Not consistent with siting criteria for clustered development to allow for consolidated use of export cables and O&amp;M economies and optimization of cable route lengths. Not meeting these criteria would affect constructability and cost.</li> </ul>
Project Boundary Option G	<ul style="list-style-type: none"> <li>Impacts to marine environment would be greater.</li> <li>Not consistent with siting criteria for clustered development to allow for consolidated use of export cables and O&amp;M economies and optimization of cable route lengths. Not meeting these criteria would affect constructability and cost.</li> <li>Historic and present use of the area</li> </ul>
Landfalls	
Crossing Southern End of Island Beach State Park (IBSP) for connection to Oyster Creek	<ul style="list-style-type: none"> <li>No previously disturbed areas available sufficient to meet HDD layout requirements</li> <li>Would impact wildlife management area.</li> <li>Would impact additional recreational areas during construction.</li> </ul>
Single HDD under IBSP Island Beach State Park (i.e., no landfall) for connection to Oyster Creek	<ul style="list-style-type: none"> <li>HDD design limitations due to existing geotechnical conditions, water depths, and length of HDD.</li> </ul>
Landfall North of IBSP for connection to Oyster Creek	<ul style="list-style-type: none"> <li>HVDC technology would be required due to length of offshore export cable route. Change in technology would increase potential impacts due to construction of a converter station and/or HVAC booster.</li> <li>Longer onshore and offshore cable routes would result in additional impacts over a longer period of time.</li> </ul>
Sea Isle City for connection to BL England	<ul style="list-style-type: none"> <li>Longer onshore and offshore cable routes would result in additional impacts to the public, parks, and natural resources including wetlands, and over a longer period of time.</li> <li>Cannot avoid borrow areas and their buffers.</li> <li>Onshore route would involve several stream crossings, including a major tributary of Ludlam Bay (intracoastal waterway), as well as crossings of underground pipeline connectors.</li> <li>Additional impacts to cultural resources within Sea Isle City to cultural resources including historic buildings, historic districts, and archeological grid sites.</li> </ul>
Offshore Export Cable Routes	
Exit Lease Area to the East	<ul style="list-style-type: none"> <li>HVDC technology would be required due to length of offshore export cable route. Change in technology would increase potential impacts due to construction of a converter station and/or HVAC booster.</li> <li>Longer offshore cable routes would result in additional impacts over a longer period of time.</li> </ul>
Barnegat Inlet Crossing	<ul style="list-style-type: none"> <li>Sediments in the inlet are dynamic; therefore, additional cable protection such as cable mattresses would be needed that would result in additional impacts to natural resources.</li> <li>Due to hydrodynamics at the inlet, access to the inlet by other vessels would be restricted during construction, which would result in additional impacts to other marine uses and navigation.</li> <li>Engineering and construction requirements for installing and designing cable in area of highly mobile sediments.</li> </ul>
Multiple HDDs to Cross Barnegat Bay	<ul style="list-style-type: none"> <li>Requires larger footprint during construction and would therefore result in additional environmental impacts.</li> </ul>

Design Alternative	Reason Not Carried Forward
(i.e., water-to-water HDD)	<ul style="list-style-type: none"> <li>In-water construction would be conducted over multiple seasons and temporary platforms would be in water during summer season. This would likely result in additional impacts to navigation and use of the bay in the Project Area.</li> <li>Cable cannot be pulled into long HDDs due to excessive pulling tensions.</li> </ul>
Forked River	<ul style="list-style-type: none"> <li>Design and construction constraints due to narrow channel and shallow water depths outside of the channel.</li> <li>Regulatory approval to install cable within the federally maintained navigation channel.</li> <li>Greater environmental impacts</li> </ul>
Oyster Creek Channel	<ul style="list-style-type: none"> <li>The channel is currently dredged at the entrance, which would require very deep cable burial.</li> <li>A shallow area existing just offshore of the channel would require leveling or a long cable pull with multiple interim tensioners.</li> <li>If there is a failure of the cable during operations, the entire cable throughout the Oyster Creek Channel would need to be replaced, affecting access to abutting properties and boating, and disturbing an excessive amount of material within the channel.</li> </ul>
Great Egg Harbor Inlet	<ul style="list-style-type: none"> <li>Sediments in the inlet are dynamic; therefore, additional cable protection such as cable mattresses would be needed, resulting in additional impacts to natural resources.</li> <li>Access to the inlet by other vessels would be restricted during construction, which would result in additional impacts to other marine uses and navigation.</li> <li>There is an existing USACE borrow area at the mouth of the inlet. USACE typically does not authorize crossing of borrow areas.</li> </ul>
Onshore Export Cable Routes	
Garden State Parkway	<ul style="list-style-type: none"> <li>Longer onshore export cable route, which would likely result in additional impacts to community and resources.</li> <li>Regulatory and permitting restrictions to install utility within the Parkway ROW.</li> <li>Engineering and construction limitations to install cable at edge of ROW.</li> </ul>
Abandoned Railroad in Ocean City and Upper Township	<ul style="list-style-type: none"> <li>HDD not feasible due to length of HDD and geotechnical conditions.</li> <li>Portion of the abandoned railroad is Green Acres encumbered<sup>8</sup>.</li> <li>Narrow ROW for open cut would result in the need for additional impacts.</li> <li>Longer onshore export cable route may extend construction schedule and result in additional impacts.</li> </ul>
Outside of the Study Area	<ul style="list-style-type: none"> <li>Longer onshore and offshore export route, which would result in additional impacts.</li> </ul>

## 6. Project Infrastructure and Description of Activities

### 6.1 Offshore Infrastructure and Activities

The following sections provide a description of construction and installation; operation and maintenance; and non-routine activities for offshore components of the Project.

#### 6.1.1 Project Components

##### 6.1.1.1 Foundations

Foundation types for offshore structures are summarized in **Table 6.1.1-1**. Maximum design parameters are provided under each Project component.

<sup>8</sup> The Green Acres Program was created in 1961 to acquire land and open space throughout New Jersey for preservation purposes. These land areas are held by the NJDEP and use of these lands requires specific permission from the Department.

**Table 6.1.1-1. Foundation options for offshore structures.**

	Turbine	Offshore Substation
Monopile	Yes	Yes
Piled jackets	No	Yes

The monopile with transition piece, or alternatively a one piece foundation where the transition piece is part of the monopile, design for all of the WTG locations reflects the planned type of foundation based on the preliminary site data obtained for the Project. This foundation is Orsted’s preferred foundation in Europe and has been perfected over the past 17 years. Based on the early site investigation results, the monopile was selected as it is the most economical solution, the simplest, quickest to install, and requires the least seabed disturbance. Monopile foundations typically consist of a single steel tubular section, consisting of sections of rolled steel plate welded together. A transition piece is fitted over the monopile and secured via bolts or grout. The transition piece includes boat landing features, ladders, a crane, and other ancillary components as well as a connection to the turbine tower (**Figure 6.1.1-1**). It is also possible for the monopile and transition piece to be fabricated and installed as one component, with the boat landing and other ancillary features installed subsequently. The transition piece will be painted yellow and marked according to USCG requirements. The paint will protect against corrosion. In addition, anodes will be used as cathodic protection against corrosion. Anodes are highly active metals which are attached to less active metals to attract the electrolytes that would normally corrode and weaken the less active metal. Anodes required for corrosion protection would be aluminum or similar reactive metal, which corrodes preferentially, protecting the steel of the turbine. Anodes would be installed at each WTG (number of anodes to be determined during detailed design). Maximum design parameters for monopile foundations are provided in **Tables 6.1.1-2** and **6.1.1-3**. See Appendix Z-1 for the Foundation Feasibility Study.

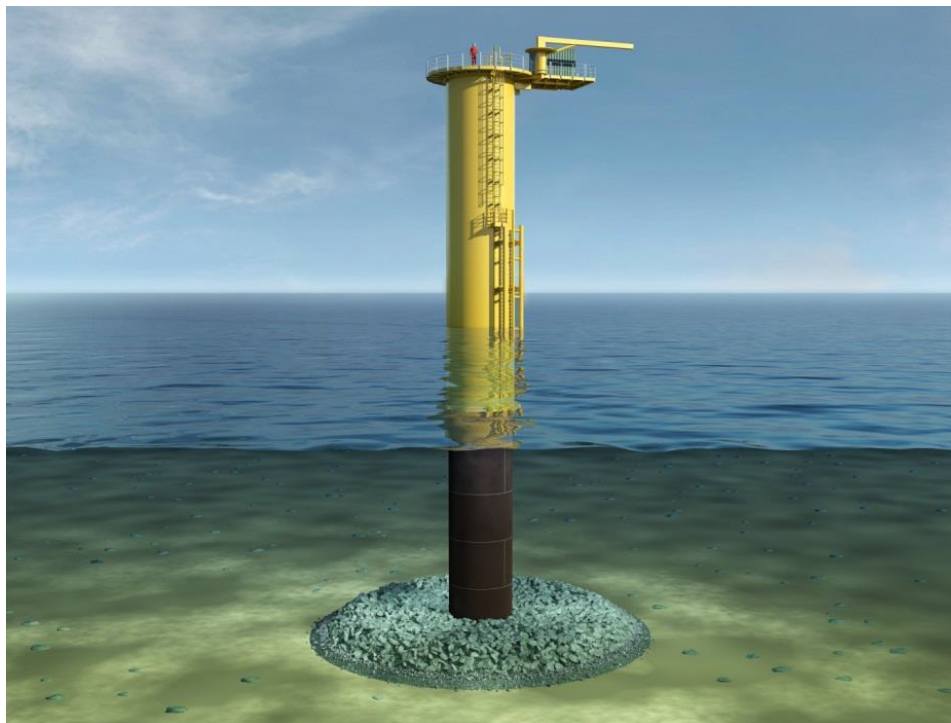

**Figure 6.1.1-1. A monopile with transition piece foundation with scour protection stone bed.**

### 6.1.1.2 Turbines

#### 6.1.1.2.1 Design Parameters

Ocean Wind has selected the GE Haliade-X 12 MW offshore wind turbine. Each turbine will have three blades connected to a central hub, forming a rotor which turns a shaft connected to the generator. The generator will be enclosed within the nacelle, which sits atop a tower structure and is able to rotate to face the oncoming wind direction. The tower will be fixed to a transition piece or foundation. In addition, if there is a delay in connecting a turbine to the grid, a temporary backup diesel generator may be installed at the turbine until the connection is made. A drawing illustrating this design is shown in **Figure 6.1.1-2**, and indicative illustrations of the exterior and interior of the WTG are shown in **Figures 6.1.1-3** and **6.1.1-4**.

**Table 6.1.1-2. Maximum design parameters for turbines.**

Parameter	Maximum Design Parameters
<b>Parameters per Turbine</b>	
Minimum lower blade tip height (ft) (relative to MLLW)	70.8
Maximum upper blade tip height (ft) (relative to MLLW)	906
Maximum rotor diameter (ft)	788

**Table 6.1.1-3. Maximum design parameters and impacts for turbine foundations.**

Parameter	Maximum Design Parameters*
<b>Parameters per Turbine Foundation</b>	
Outer diameter at seabed of main tubular structure (ft)	37
Sea surface diameter (ft)	27
Scour protection (if required) diameter (yards)	61
Scour protection (if required) layer thickness (ft)	8.2
Seabed structure area per monopile (acres)	0.023
Seabed scour protection (if required) area per monopile (acres)	0.59
Seabed permanent area affected per monopile (acres)	0.85
Scour protection (if required) volume per monopile (cubic yards)	7,764
Pile structure grout volume per monopile (cubic yards)	144
Seabed penetration (ft)	164
Maximum hammer energy kilojoules (kJ)	4,000
Indicative continuous piling duration per turbine (hours)	4
<b>Maximum Total Impacts for Wind Turbine Foundations</b>	
Maximum number of turbines	98
Total seabed structure area (acres)	2.3
Total scour (if required) protection area (acres)	58
Total permanent affected area (acres)	60.3
Total scour (if required) protection volume (cubic yards)	761,000
Total pile structure grout volume (cubic yards)	14,000

Notes:

\*Total foundation values based on 99 monopile foundations for wind turbines. The PDE was subsequently reduced to 98 turbines; because the PDE was reduced (not increased), the impact assessment was not changed. Totals have been rounded up in some cases.

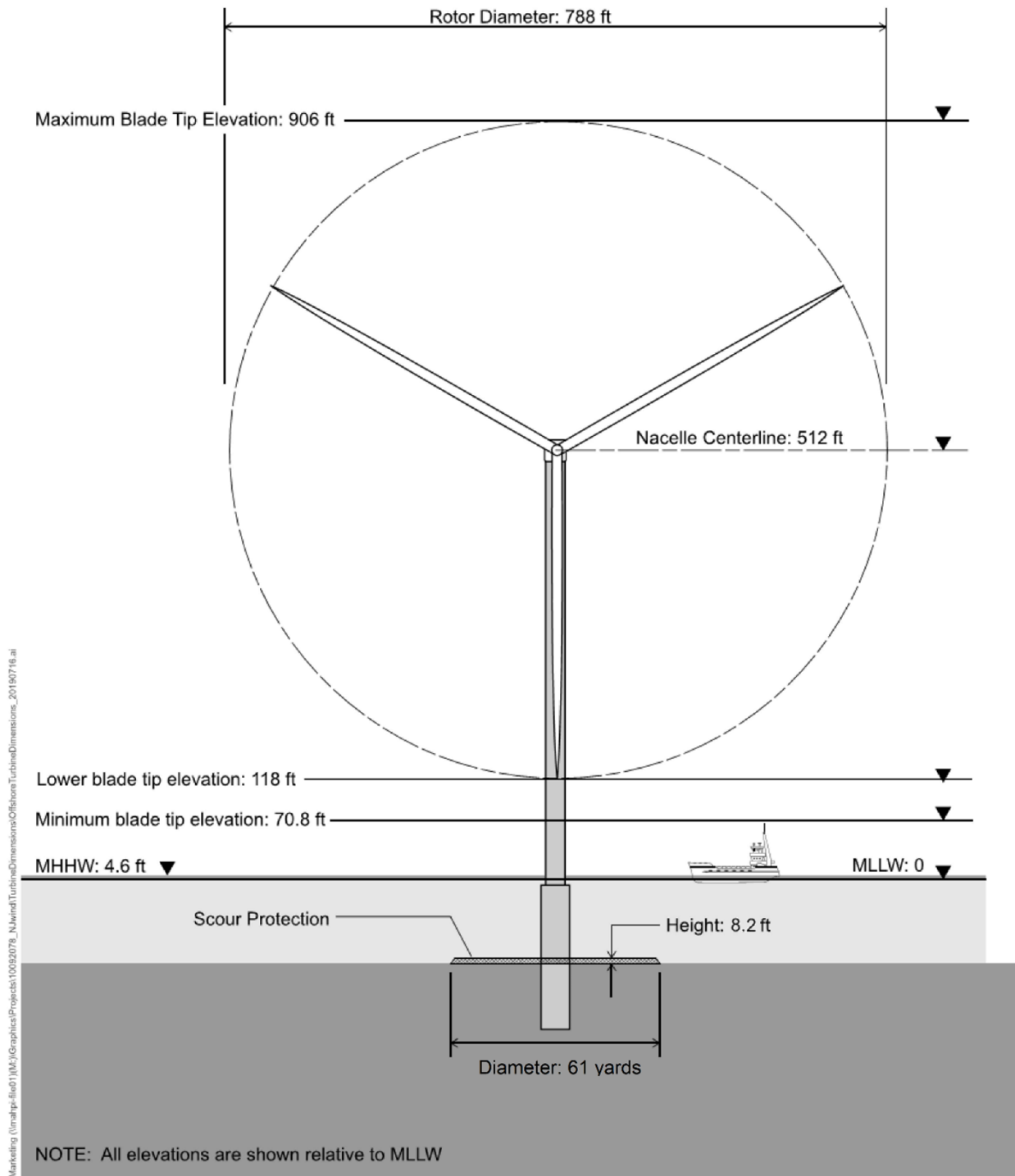

**Figure 6.1.1-2. Maximum design scenario for wind turbines.**





Figure 6.1.1-3. WTG exterior - indicative.

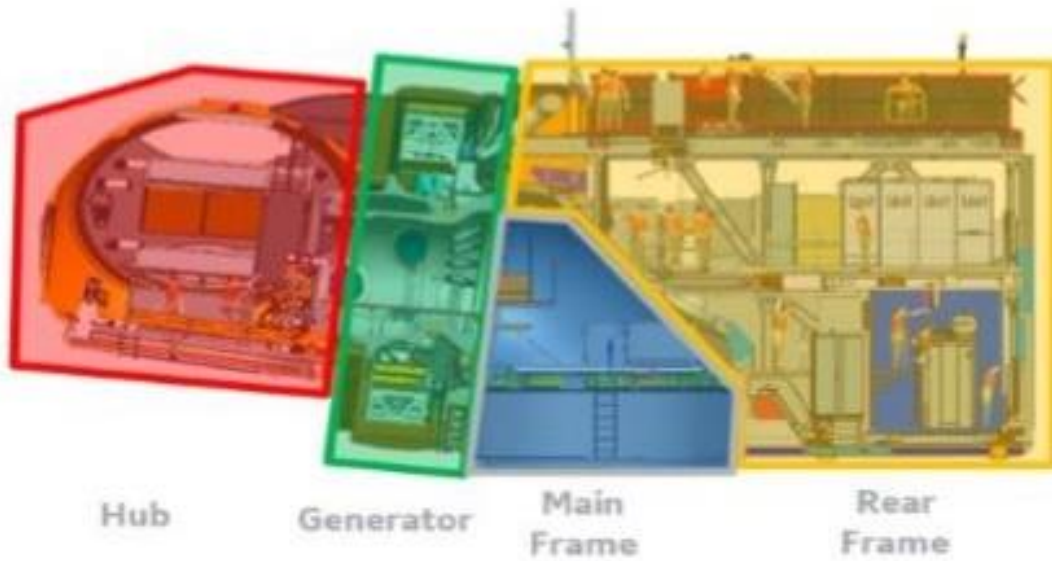

Figure 6.1.1-4. WTG interior - indicative.

#### 6.1.1.2.2 Access

The turbines may be accessed from a vessel via a personnel lifting and/or ladder climbing system or stabilized gangway to the foundation.

#### 6.1.1.2.3 Control Systems

Each turbine will have its own control system to carry out functions like yaw control and ramp down in high wind speeds. These systems can be controlled manually from within the turbine nacelle or tower base, or remotely. The turbines will be connected to a central SCADA system for control of the Project remotely. The SCADA system will communicate with the wind farm via fiber optic cables, microwave, or satellite links. This allows for remote turbine shutdown if faults occur.

Up to two wave buoys will be installed in the Wind Farm Area to collect surface measurements of metocean conditions during the construction stage. After construction one wave buoy will stay in place for up to five years to support a structural monitoring campaign on one WTG. The location of these buoys are to be decided once the WTG to be tested is determined. Buoys will be located up to a maximum distance of 1,640 ft (500 m) from the WTG. See Appendix W for additional discussion.

#### 6.1.1.3 Offshore Substations

Offshore substations are required for AC transmission systems dependent on the system design. The purpose of the offshore substation is to stabilize and maximize the voltage of power generated offshore, reduce the potential electrical losses, and transmit electricity to shore. Up to three offshore substations may be required to collect the electricity generated by the offshore turbines. The voltage will be 'stepped up' to a higher voltage by transformers on the substation before transmission to shore.

The offshore substations will likely consist of a topside structure and a foundation substructure (examples shown in **Figure 6.1.1-5** to **6.1.1-7**). The topside structure may have one or more decks. The offshore substations will carry equipment for high voltage transmission and distribution and will include the equipment required to switch and transform electricity to higher voltage and provide compensation. They may also include equipment and facilities for operating, maintaining, and controlling the substation and access to the substation by vessels.



**Figure 6.1.1-5. Indicative monopile foundation offshore substation (London Array).**



**Figure 6.1.1-6. Indicative offshore substation with piled jacket foundation (Racebank).**



**Figure 6.1.1-7. Indicative offshore substation with helideck (Hornsea I).**

Access to the offshore substations will be provided from a boat landing. The boat landing located at the offshore substation substructure provides access to the cable deck via a staircase and an intruder cage will be installed to prevent unauthorized access to the offshore substations. In case of emergency on the offshore substation, the platform can be abandoned by means of life rafts. The main platform may include a helicopter platform (helideck). Other equipment will include a backup diesel generator, batteries, panels for WTG control, and communication and SCADA system equipment.

Array cables transferring electrical energy from the WTGs terminate at the offshore substation cable deck. At the offshore substation, the incoming electrical energy is passed through a suite of switchgear equipment and step-up transformers where the voltage levels are appropriately increased for distribution and transmission to the onshore substation via the export cable systems.

The topside structure will accommodate the transformer and high voltage components comprising the electrical transmission and distribution systems. The offshore substation also provides for the medium- and low-voltage electrical systems that power the on-board mechanical components, such as cranes and beam hoists, and electrical services such as fire alarm systems, fire emergency systems and communication systems.

Structurally, the topside are typically a steel brace column system with architectural walls that act as a climate shield and be non-load-bearing except for local wind loads. The main braces and columns are circular or tubular members, and members throughout the decks will be wide H-flange profile beams. This design is used in most of the offshore oil and gas installations worldwide. The benefits of the design include:

- Wide availability of a global and competent fabricator supply base that is adept at fabricating similar topside design schemes for industries other than offshore wind;
- Feasibility for parallel fabrication process because each deck may be concurrently fabricated; and
- Added flexibility to incorporate design changes during the fabrication process.

Irrespective of the final design developed by the Project, all elements will be subject to certification.

The helideck structure will consist of a main deck structure and welded lattice support structure and sub-frame, weighing roughly 220 tons. The helideck would be electrically and mechanically equipped to accommodate systems such as, but not limited to:

- Helideck re-fueling and drainage system;
- Deck integrated fire-fighting;
- Fire emergency and fire alarm system;
- Communication systems;
- Closed circuit television; and
- Surrounding netting.

In the offshore substation, each array cable circuit connects to a 66 kV gas insulated circuit breaker which in-turn is connected via an integral busbar system. Interconnecting cables connect the 66 kV busbars to two oil-filled power transformers via dedicated circuit breakers. Each of the transformers steps-up the 66 kV array system voltage to the transmission system voltage. The high voltage side of the transformers are connected to a common busbar via a dedicated circuit breaker. The high voltage busbar allows a common electrical connection to be made to the oil-filled shunt reactor (designed to provide inductive reactance to compensate for the export cable’s capacitive reactance) and the subsea export cables.

Typically, the offshore substation comprises the following high voltage and medium voltage electrical components:

- One gas-insulated switchgear, consisting of one export cable bay with T-off to the shunt reactor, one interlink cable bay and two transformer feeder bays;
- One shunt reactor;
- Two main transformers;
- One 66 kV gas-insulated switchgear, consisting of two Busbars connected with a Bus-coupler, seven array bays, and two transformer feeder bays;
- Two 66/0,48 kV, 500 kilovolt-amp (KVA), emergency auxiliary transformers for auxiliary voltage supply and earthing of main transformers; and
- Two neutral earthing resistors for earthing of the neutral point of auxiliary transformers.

Equipment for wind monitoring will also be included. Housing accommodations, storage, workshop and logistics facilities for operating and maintaining the offshore wind turbines may also be included.

Construction vessels may refuel at sea due to multiday offshore operations. However, construction support vessels will not refuel at sea. All vessels will be certified by the Project to conform to vessel operations and maintenance protocols designed to minimize the risk of fuel spills and leaks. Maximum design parameters for substation topsides are provided in **Table 6.1.1-4**. Representative locations for the offshore substations are shown on **Figures 4.1-1** and **4.1-2**.

**Table 6.1.1-4. Maximum design parameters for topside offshore substations.**

Parameter	Maximum Design Parameter
Number of substations	3
Length of topside main structure (ft)	230
Width of topside main structure (ft)	230
Length of topside main structure inclusive of ancillary structures (ft)	295
Width of topside main structure inclusive of ancillary structures (ft)	295

Parameter	Maximum Design Parameter
Total structure height - including ancillary structures (ft) (relative to MLLW)	296
Bridge links link length (ft)	328

Monopile or piled jacket foundation types are being considered to allow for an assessment of potential impacts while maintaining flexibility that will allow Ocean Wind to select the appropriate substation foundations available as technology evolves. Maximum design parameters and impacts for substation foundations are provided in **Table 6.1.1-5**. Design of these foundations is described below and maximum design parameters for piled jacket foundations are provided in **Table 6.1.1-6**.

**Table 6.1.1-5. Maximum design parameters and impacts for substation foundations.**

Parameter	Maximum Design Parameters (per foundation)	Maximum Scenario Foundation Type
Maximum number of structures	3	-
Maximum scour protection (if required) dimension (yards)	72	Monopile
Maximum structure dimension at seabed (yards)	77	Piled Jacket
Maximum structure dimension at sea surface (yards)	77	Piled Jacket
Number of Piles	16	Piled Jacket
Seabed preparation area (acres)	0	N/A
Seabed gravel bed area (acres)	0	N/A
Seabed structure area (acres)	0.04	Monopile
Seabed scour protection (if required) area (acres)	1	Monopile
Seabed total permanent area (acres)	0.6	Piled Jacket
Scour protection (if required) volume (cubic yards)	1,721	Piled Jacket
Pile-structure grout volume (cubic yards)	222	Piled Jacket

#### 6.1.1.3.1 Monopile Foundations for Substations

Design parameters for monopile foundations would be the same as described above for turbine monopile foundations. For substation application, a modular support frame would be installed atop the monopile foundation to support the topside. The modular support frame will be equipped with an integrated cable deck.

#### 6.1.1.3.2 Substation Piled Jacket Foundations

A piled jacket foundation, being considered for the offshore substations only (**Table 6.1.1-1**), is formed of a steel lattice construction (comprising tubular steel members and welded joints) secured to the seabed by means of hollow steel pin piles attached to the jacket feet. Unlike monopiles, there is no separate transition piece. The transition piece and ancillary components are fabricated as an integrated part of the jacket. The final offshore substation foundation selected, and associated design specifications will be determined by the final engineering design process, informed by factors including seabed conditions, wave and tidal conditions, Project

economics, and procurement approach. Detailed information on the foundation selected will be included in the facility design report/fabrication and installation report (FDR/FIR), to be reviewed by the CVA and submitted to BOEM prior to construction.

The offshore substation foundations will include an anti-corrosion cathodic protection system comprising multiple anode bars, J-tubes for array and export cables, boat landings, and access ladders with resting platforms.

Maximum design parameters and impacts for substation piled jacket foundations are provided in **Table 6.1.1-6**.

**Table 6.1.1-6. Maximum design parameters for piled jacket foundations for substations.**

Parameter	Maximum Design Parameters (per foundation)
Number of legs per foundation	6
Number of piles per foundation (4 piles per corner)	16
Separation of adjacent legs at seabed (ft)	230
Separation of adjacent legs at sea surface(ft)	230
Height of platform above MLLW (ft)	131
Jacket leg diameter (ft)	15
Pin pile outer diameter at seabed (ft)	8
Mud-mat area (ft <sup>2</sup> )	4,306
Seabed structure area (acre)	<0.1
Seabed scour protection (if required) area (acres)	0.2
Seabed total permanent area (acres)	0.6
Scour protection (if required) volume (cubic yards)	1,721
Pile-structure grout volume (cubic yards)	222
Embedment depth (below seabed) (ft)	230
Maximum hammer energy (kJ)	2,500
Maximum piling duration per foundation (days)*	15
Indicative continuous piling duration per pile (hours)*	4

\* The 15 days is inclusive of activities (i.e., mobilization, clearance times, demobilization) and not just pile driving. The indicative piling duration per pile is 4 hours. The maximum active piling duration per foundation would be up to 64 hours (16 piles per foundation x 4 hours per pile) spread over up to 15 days.

#### 6.1.1.4 Array Cables

Cables carrying the electrical current produced by the turbines will link the turbines to an offshore substation. Several turbines will typically be grouped together on the same cable 'string' connecting those turbines to the substation. Multiple cable strings will connect back to each offshore substation. During the detailed design, consideration will be given to using array cables as backlinks to ensure turbines can remain powered if a fault should occur in the array cable string.

The array cables will consist of a number of conductor cores, usually made from copper or aluminum surrounded by layers of insulating material as well as material to armor or protect the cable from external damage. **Figure 6.1.1-8** provides a cross section of a typical array cable. Maximum design parameters and impacts are provided in **Table 6.1.1-7**.



**Figure 6.1.1-8. Typical array, interconnector, and offshore export cable cross section.**

The array cables will be installed below the seabed where possible. The target burial depth for array cables may vary based on existing conditions and potential risks, such as trawling and vessel anchors (**Figure 6.1.1-9**). The target burial depth is determined based on an assessment of seabed conditions integrated from geophysical and geotechnical surveys, seabed mobility, and the risk of interaction with external hazards such as fishing gear and vessel anchors, while also considering other factors such as maintained navigational channels and thermal conductivity.



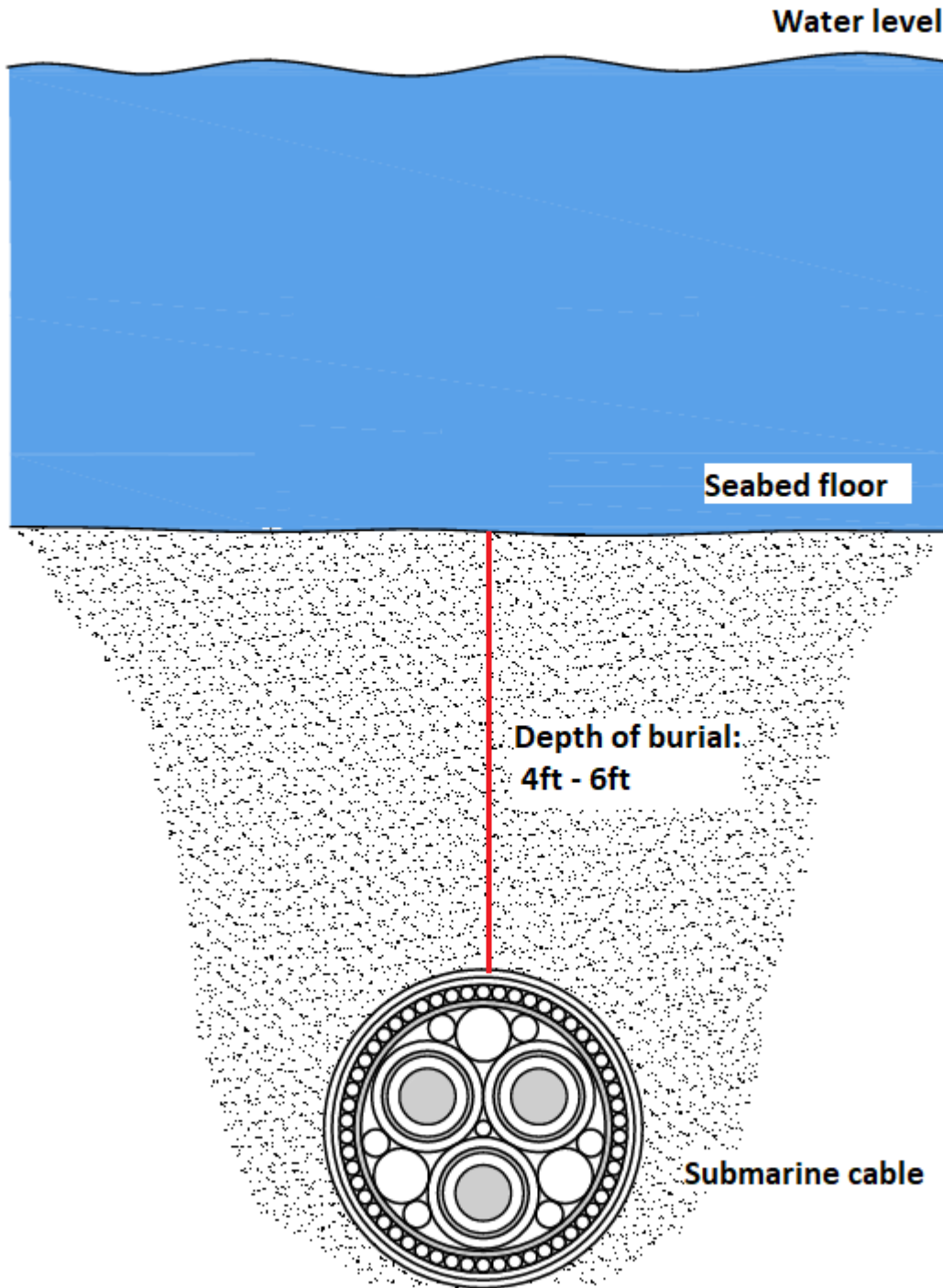

Figure 6.1.1-9. Indicative burial for array, interconnector, and offshore export cable (depth could be less based on cable burial risk assessment).

Where burial cannot occur, sufficient burial depth cannot be achieved, or protection is required due to array cables crossing other cables or pipelines, additional armoring or other cable protection methods may be used. Cable protection methods may include rock placement, concrete mattresses, frond mattresses, rock bags, and seabed spacers. These are described in greater detail in Section 6.1.2.6.

The maximum design parameters and assumptions for array cables are provided in **Table 6.1.1-7**. The values presented in the table will be refined when the survey results have been analyzed and incorporated into the design.

**Table 6.1.1-7. Array cable design parameters and impacts.**

Parameter	Maximum Design Parameters
Cable diameter (inches)	8
Estimated total length of cable (miles)	190
Typical voltage (kV)	66
Maximum voltage (kV)	170
Target burial depth (ft) (final burial depth based on Cable Burial Risk Assessment)	4 - 6
Cable separation - typical (ft)	328
Offshore Cable disturbance corridor width (ft)	82
<b>Maximum Total Impacts for Array Cables</b>	
Full corridor width seabed disturbance (acres)	1,850 <sup>1</sup>
Boulder clearance - seabed disturbance (acres)	2,220 <sup>2</sup>
Sandwave clearance - seabed disturbance (acres)	220 <sup>6</sup>
Sandwave clearance - material volume (cubic yards)	588,580 <sup>3</sup>
Burial spoil: jetting/plowing/control flow excavation material volume (cubic yards)	2,354,000 <sup>4</sup>
Percent of cable requiring protection	10%
Cable protection area (acres) <sup>5</sup>	77
Cable protection volume (cubic yards)	341,000
Cable/pipe crossings: pre- and post-lay rock berm area (acres)	0
Cable/pipe crossings: pre- and post-lay rock berm volume (cubic yards)	0

<sup>1</sup>Assumes 82-foot wide corridor disturbed

<sup>2</sup>Assumes 98-foot wide corridor and 100% of route affected

<sup>3</sup>Assumes 98-foot wide corridor, 17-foot average height, and 1% of route affected

<sup>4</sup>Assumes 95% with shallow burial depth (4 to 6 ft) and 5% with deep burial (33 ft)

<sup>5</sup>Could be rock, mattress, frond mattress, rock bags or seabed spacers as described in Section 6.1.2.6.3 Cable Protection

<sup>6</sup>Assumes 98-foot wide corridor and 1% of route affected

#### 6.1.1.5 Substation Interconnector Cables

Substation interconnector cables will connect the offshore substations to each other. Up to two cables will be installed with each cable linking two substations. The substation interconnector cables are usually made from copper or aluminum surrounded by layers of insulating material as well as material to armor or protect the cable from external damage. **Figure 6.1.1-8** provides a cross section of a typical substation interconnector cable.

As described for the array cables, the substation interconnector cables will be buried below the seabed whenever possible and that depth may vary. The target burial depth is determined based on an assessment of seabed conditions integrated from geophysical and geotechnical surveys, seabed mobility, and the risk of

interaction with external hazards such as fishing gear and vessel anchors, while also considering other factors such as maintained navigational channels and thermal conductivity. The target burial depths will be determined through a post-COP approval Cable Burial Risk Assessment, and where burial cannot occur, sufficient depth cannot be achieved, or protection is required due to interconnector cables crossing other cables or pipelines, additional armoring or other cable protection methods may be used.

The maximum design parameters for substation interconnector cables are provided in **Table 6.1.1-8**. The values presented in the table will be refined when the survey results have been analyzed and incorporated into the design.

**Table 6.1.1-8. Substation interconnector cable parameters and impacts.**

Parameter	Maximum Design Parameters
Number of substation interconnector cables	2
Estimated total length of cable (miles)	19
Cable diameter (inches)	13
Maximum voltage (kV)	275
Target burial depth (ft) (final burial depth dependent on cable burial risk assessment and coordination with agencies)	4-6
Cable seabed disturbance width (ft)	82
<b>Maximum Total Impacts for Substation Interconnection Cables</b>	
Total seabed disturbed - full corridor width (acres)	185 <sup>1</sup>
Seabed disturbed- boulder clearance (acres)	222 <sup>2</sup>
Seabed disturbed- sandwave clearance (acres)	2 <sup>6</sup>
Sandwave clearance volume (cubic yards)	58,860 <sup>3</sup>
Burial spoil - jetting/plowing/control flow excavation volume (cubic yards)	235,000 <sup>4</sup>
Cable protection area (acres) <sup>5</sup>	8
Cable protection volume (cubic yards)	34,000
Percent of cable requiring protection	10%
Cable/pipe crossing- pre- and post-lay rock berm area (acres)	0
Cable/pipe crossing- pre- and post-lay rock berm volume (cubic yards)	0

<sup>1</sup>Assumes 82-foot wide corridor disturbed

<sup>2</sup>Assumes 98-foot wide corridor and 100% of route affected

<sup>3</sup>Assumes 98-foot wide corridor, 17-foot average height, and 1% of route affected

<sup>4</sup>Assumes 95% with shallow burial depth (4 to 6 ft) and 5% with deep burial (33 ft)

<sup>5</sup>Could be rock, mattress, frond mattress, rock bags or seabed spacers as described in Section 6.1.2.6.3 Cable Protection

<sup>6</sup>Assumes 98-foot wide corridor and 1% of route affected

#### 6.1.1.6 Offshore Export Cables

Offshore export cables will carry electrical power from the offshore substation to the onshore TJB, where the offshore export cable will be joined to the onshore export cable. Offshore export cables will be installed below the seabed and buried onshore up to the TJB. The Project will include two interconnection points; at BL England and Oyster Creek as depicted on **Figure 1.1-1**. See Appendix Z-2 for the Cable Burial Feasibility Assessment.

One offshore export cable would make landfall and deliver electrical power at the existing BL England substation and up to two offshore export cables would make landfall and deliver electrical power at the existing Oyster Creek substation.

As described for the array cables, the offshore export cables will be buried below the seabed where possible. The target burial depths will be determined following detailed design and Cable Burial Risk Assessment. The target burial depth is determined based on an assessment of seabed conditions integrated from geophysical and geotechnical surveys, seabed mobility, and the risk of interaction with external hazards such as fishing gear and vessel anchors, while also considering other factors such as maintained navigational channels and thermal conductivity. Where burial cannot occur, sufficient depth cannot be achieved, or protection is required due to the export cable crossing other cables or pipelines, additional armoring or other cable protection methods may be used.

The maximum design parameters for offshore export cables are provided in **Tables 6.1.1-9** and **6.1.1-10**. The values presented in the table will be refined when the survey results have been analyzed and incorporated into the design.

**Table 6.1.1-9. Offshore export cable design parameters.**

Parameter	Design Parameters
Offshore export cable diameter (inches)	13
Typical export cable voltage (kV)	275
Cable seabed disturbance width per cable (ft)	82
Target burial depth (ft) (final burial depth based on cable burial risk assessment)	4-6
Cable weight in air (kg/m)	138
Cable weight in water (kg/m)	90

**Table 6.1.1-10. Maximum total impacts for offshore export cables.**

Parameter	Within the Wind Farm Area	Outside the Wind Farm Area	Total Export Cable*
<b>Oyster Creek</b>			
Number of cable sections per cable	4		
Number of cable joints	3		
Offshore cables	2		
Length of offshore export cable route (miles)	3	69	72
Length of offshore export cable (miles) (2 cables within corridor)	6	136	143
Full corridor width seabed disturbance (acres)	70	1,360	1,430 <sup>1</sup>
Boulder clearance- seabed disturbance (acres)	70	1,630	1,710 <sup>2</sup>
Sandwave clearance- seabed disturbance (acres)	1	16.3	17 <sup>6</sup>
Sandwave clearance- material volume (cubic yards)	19,620	431,620	451,240 <sup>3</sup>
Burial spoil: vertical injection material volume (cubic yards)	29,000	636,000	665,000 <sup>4</sup>

Parameter	Within the Wind Farm Area	Outside the Wind Farm Area	Total Export Cable*
Burial spoil: plowing/control flow excavation material volume (cubic yards)	78,000	1,726,000	1,805,000
Cable protection area (acres) <sup>5</sup>	2	68	70
Cable protection volume (cubic yards)	12,000	388,000	400,000
Percent of cable requiring protection			10%
Cable/pipe crossings: pre- and post-lay rock berm area (acres)	0	48	48
Cable/pipe crossings: pre- and post-lay rock berm volume (cubic yards)	0	279,000	279,000
<b>BL England</b>			
Number of cable sections per cable		3	
Number of cable joints		2	
Offshore cables		1	
Length of offshore export cable route (miles)	4	28	32
Length of offshore export cable (miles) (1 cable within corridor)	4	28	32
Full corridor width seabed disturbance (acres)	50	270	320 <sup>1</sup>
Boulder clearance- seabed disturbance (acres)	50	350	400 <sup>2</sup>
Sandwave clearance- seabed disturbance (acres)	<1	3.5	4 <sup>6</sup>
Sandwave clearance- material volume (cubic yards)	11,770	88,290	100,060 <sup>3</sup>
Burial spoil: vertical injection material volume (cubic yards)	17,000	129,000	148,000 <sup>4</sup>
Burial spoil: plowing/control flow excavation material volume (cubic yards)	47,000	353,000	400,000
Cable protection area (acres) <sup>5</sup>	2	14	16
Cable protection volume (cubic yards)	7,000	80,000	87,000
Percent of cable requiring protection			10%
Cable/pipe crossings: pre- and post-lay rock berm area (acres)	0	12.6	12.6
Cable/pipe crossings: pre- and post-lay rock berm volume (cubic yards)	0	75,000	75,000

\* Some differences may occur due to rounding

<sup>1</sup>Assumes 82-foot wide corridor disturbed

<sup>2</sup>Assumes 98-foot wide corridor and 100% of route affected

<sup>3</sup>Assumes 98-foot wide corridor, 17-foot average height, and 1% of route affected

<sup>4</sup>Assumes 95% with shallow burial depth (4-6 ft) and 5% with deep burial (33 ft)

<sup>5</sup>Could be rock, mattress, frond mattress, rock bags or seabed spacers as described in Section 6.1.2.6.3 Cable Protection

<sup>6</sup>Assumes 98-foot wide corridor and 1% of route affected

Up to six nearshore floating or bottom mounted Acoustic Doppler Current Profilers (ADCPs) will be deployed in 33 ft (10 m) of water directly in front of the cable landfall points and along the cable route at deeper locations,

and up to one wave buoy and/or bottom mounted ADCP may be deployed in Barnegat Bay, to support the cable installation works. Ocean Wind will ensure that these instruments will not be a hazard to navigation for vessels transiting the Wind Farm Area; locations will be published in the local Notice to Mariners. These will provide real-time wave and current data to the installation vessels through telemetry from a surface buoy. The exact number and location of these instruments are pending final route and cable design. Coordination with stakeholders will ensure they are positioned at a distance that they will not disrupt operations. See Appendix W for an overview of the proposed systems and further discussion.

## 6.1.2 Construction

### 6.1.2.1 Site Preparation Activities

A number of site preparation activities are necessary in the Wind Farm Area and offshore cable corridor prior to the start of construction. An overview of these activities is provided below.

#### 6.1.2.1.1 Pre-construction Surveys

Ocean Wind is conducting a phased site investigation campaign which will include HRG&G surveys of the Wind Farm Area, export cable route corridors and landfalls. These surveys have begun and will continue prior to the start of construction to identify detailed seabed conditions and morphology, verify seabed layers, and to determine the presence or absence of potential hazards or obstructions. For the HRG surveys, remote sensing techniques include side scan sonar, sub-bottom profiling, multibeam bathymetry, and backscatter and high-density magnetometer surveys.

Geotechnical surveys will include borings, cone penetration tests, and vibrocores. Prior to final cable routing and micro siting of all assets, the Project will implement an Unexploded Ordnance/ Munitions and Explosives of Concern (UXO/MEC) Risk Assessment with Risk Mitigation Strategy (RARMS) designed to evaluate and reduce risk in accordance with the As Low As Reasonably Practicable (ALARP) risk mitigation principle. The RARMS consists of a phased process beginning with a Desktop Study and Risk Assessment that identifies potential sources of UXO/MEC hazard based on charted UXO/MEC locations and historical activities, assesses the baseline (pre-mitigation) risk that UXO/MEC pose to the Project, and recommends a strategy to mitigate that risk to ALARP. The UXO/MEC Risk Assessment with Risk Mitigation Strategy for the Project and other supplemental UXO/MEC information is included in Appendix X.

#### 6.1.2.1.2 UXO/MEC Risk Mitigation

Avoidance is the preferred approach for UXO/MEC mitigation; however, it is anticipated that there may be instances where confirmed UXO/MEC avoidance is not possible due to layout restrictions, presence of archaeological resources, or other factors that preclude micro siting. In such situations, confirmed UXO/MEC may be removed through in-situ disposal or physical relocation. Selection of a removal method will depend on the location, size, and condition of the confirmed UXO/MEC, and will be made in consultation with a UXO/MEC specialist and in coordination with the appropriate agencies.

In-situ disposal of MEC/UXO will be done with low order (deflagration) or high order (detonation) methods or by cutting the MEC/UXO to extract the explosive components. The UXO/MEC might also be relocated through a "Lift and Shift" operation, in which case the relocation will be to another suitable location on the seabed within the APE or previous designated disposal areas for either wet storage or disposal through low or high order methods as described for in situ disposal. For all UXO/MEC clearance methods, safety measures such as the use of guard vessels, enforcement of safety zones, and others will be identified in consultation with a UXO/MEC specialist and the appropriate agencies and implemented as appropriate.

During Project construction, the likelihood of UXO/MEC encounter is very low. HRG surveys and data analysis are still underway, and the exact number and type of UXOs in the Project area are not yet known. As a conservative approach however, it is currently assumed that up to 10 UXOs may have to be detonated in place. If necessary, these detonations would occur on up to 10 different days (i.e., one detonation would occur per day). Ocean Wind will work with BOEM to identify appropriate response actions, which may include developing an emergency response plan, conducting UXO/MEC-specific safety briefings, retaining an on-call UXO/MEC consultant, or other measures (See Appendix X for additional detail).

#### 6.1.2.1.3 Boulder Clearance

There is a potential to encounter boulders during construction and installation of the offshore infrastructure. Boulders pose the following risks:

- Exposed or shallow buried cables that may require post-lay cable protection such as armoring with rock or concrete mattresses;
- Obstruction of cable installation equipment that may lead to failure to reach cable burial depth, equipment damage, and/or delayed cable installation due to multiple installation passes; and
- Risk of damage to cable assets.

The results of HRG surveys will be used to determine where boulders occur and to inform decisions regarding micro-siting to avoid boulders or which clearance methods will be used.

Boulder clearance will take place prior to construction to clear the cable corridor in preparation for trenching and burial operations. A combination of displacement plow, subsea grab or in shallower waters a backhoe dredger may be used to clear boulders and undertake route clearance activities.

For dense boulder fields, a displacement plow will most likely be used to clear boulders. A displacement plow (**Figure 6.1.2-1**) is a Y-shaped tool composed of a boulder board attached to a plow. The plow is pulled along the seabed and scrapes the seabed surface pushing boulders out of the cable corridor. The plow is lightly ballasted to clear the corridor of boulders, but not create a deep depression in the seabed. A displacement plow cannot be used in areas where slopes are steep. A displacement plow is not practical where it may encounter large obstacles (force greater than 80 metric tons) that may shift or rotate the tool, causing reduced clearance effectiveness or damage to the tool. Multiple passes may be required dependent on the burial tool selected and seabed conditions.

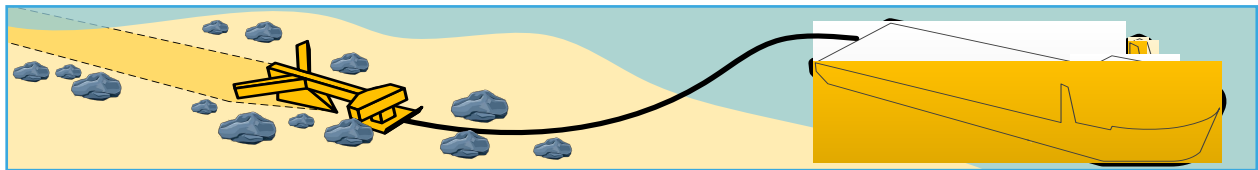
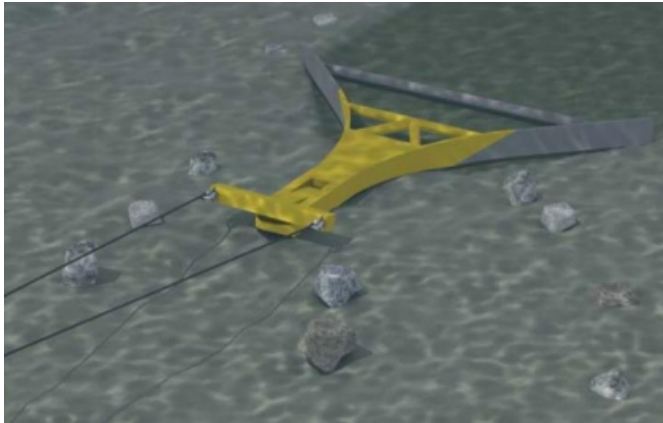

**Figure 6.1.2-1. Examples of displacement plow.**

Where there are steep slopes, large obstructions occur, or boulder density is low, a subsea grab (**Figure 6.1.2-2**) may be used. The subsea grab is an effective way to relocate individual boulders with limited interaction with and disturbance of the seabed.

The subsea grab is equipped with a survey and ROV spread to assist in subsea positioning of the grab onto a boulder and to record the boulder's new position. The presence, position, and nature of the boulders will be visually confirmed through ROV inspection.

In shallower waters, a backhoe dredger may be used. A backhoe dredger is a type of mechanical excavator mounted on a vessel, pontoon or amphibious vehicle. Backhoe dredgers are widely used in shallow waterways and shores to remove vegetation and undertake targeted route clearance.





**Figure 6.1.2-2. Example subsea grab**

Source: DEME Group; Hornsea 3 2018

Results of the geophysical surveys will be used to determine where boulder clearing would be required and to plan which clearing tool to use.

#### 6.1.2.1.4 Pre-lay Grapnel Run

There is a potential to encounter obstructions during installation of the cables, such as abandoned cables, fishing gear, and marine debris. Obstructions pose risks of damage to cables and installation tools, as well as installation delays.

Following pre-construction surveys, possible UXO clearance, and boulder clearance, a series of grapnels will be towed along the final cable route to locate and clear remaining obstructions prior to cable installation (i.e., a pre-lay grapnel run). A pre-lay grapnel run will be undertaken usually no more than two weeks before installation of the cable along a particular route length. This is to minimize the risk of obstructions (e.g., fishing lines) from obstructing the cable-lay operation as shown in **Figure 6.1.2-3**.

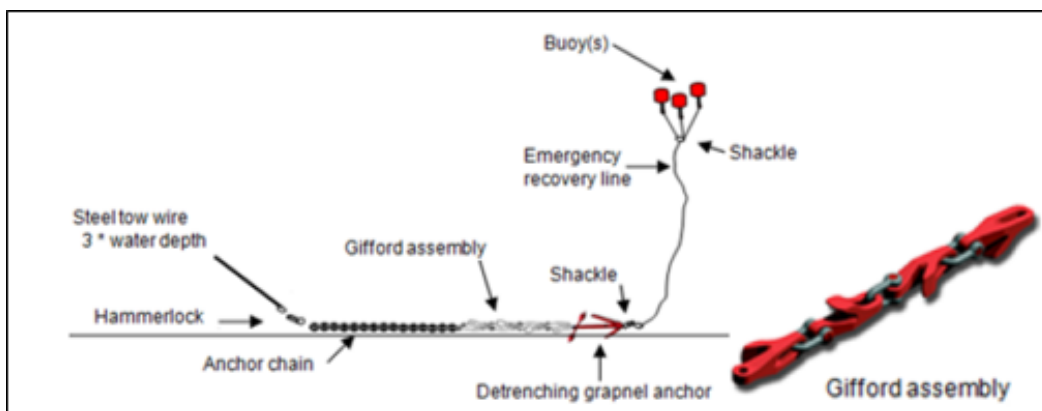

**Figure 6.1.2-3. Example pre-lay grapnel run string.**

Items will be recovered and taken to a licensed disposal facility or if appropriate relocated outside the cable route. Results of the survey will be used to determine the need for further clearance activities. Out-of-service or abandoned cables crossing the cable route will be recovered, cut, and removed from the cable route. Cable removal will be carried out in consultation with the cable owner and in accordance with International Cable Protection Committee guidelines.

#### 6.1.2.1.5 Sandwave Clearance and Dredging

Sandwaves are generally mobile slopes of sediment on the seabed. Cables must be buried at a depth beneath the level where natural sandwave movement would uncover them. In addition, the natural slope of the sandwaves can pose a hazard for installation tools that require a relatively level surface to operate effectively. In some cases, it is necessary to remove the mobile sediments prior to cable installation.

Sandwave clearance will be completed as needed within the Wind Farm Area and along the offshore cable export corridor in advance of cable installation. Sandwave clearance volumes were estimated based on the sandwave height, anticipated cable burial depth, likely installation technique, and required clearance area.

Sandwave clearance may be undertaken where cable exposure is predicted over the lifetime of the Project due to seabed mobility. This facilitates cable burial below the reference seabed. Alternatively, sandwave clearance may be undertaken where slopes become greater than approximately 10° (17.6 percent), which could cause instability to the burial tool. The work could be undertaken by traditional dredging methods such as a trailing suction hopper. Sandwave clearance may also require CFE or sandwave removal plow to side cast material if necessary, for cable installation, multiple passes may be required. The method of sandwave clearance will be chosen based on the results from the site investigation surveys and cable design.

Where there is a time gap between sandwave clearing and installation, the area may start to infill. Where this occurs, pre-sweeping may be required to remove partial infill, as discussed in the next section.

Maintenance dredging may be required in the Oyster Creek Federal Channel to allow construction vessel access into Barnegat Bay. Dredging for the purposes of cable installation may take place in the Atlantic Ocean HDD exit pits and in Barnegat Bay (Prior Channel option and Holtec landfall).

#### 6.1.2.1.6 Seabed Preparation for Foundations

Some form of seabed preparation may be required for each foundation type. Seabed preparation may include seabed levelling and removal of surface or subsurface debris such as boulders, lost fishing gear, or lost anchors. Excavation may be required where debris is buried or partially buried. Seabed preparation for piled jacket foundations may include placement of a layer of stone, if conditions are muddy, to prevent the jacket structure from subsiding in deep mud or slipping on mud while the first pile is being driven.

#### 6.1.2.2 Foundations

Monopiles and transition pieces are expected to be manufactured in Europe and transported across the Atlantic Ocean to a U.S. feeder port where their assembly is completed. Potential feeder ports are identified in Section 4.1.1. Two European-based installation vessels will sail directly to the Wind Farm Area, and the monopiles and transition pieces will be transported from the port to the Wind Farm Area using feeder barges.

Special vessels will be needed to transport and install foundations (see vessels Sections 6.1.2.4.2, 6.1.2.5, 6.1.2.6.5, 6.1.2.7, and 6.1.2.8). A filter layer and/or scour protection layer (typically rock) (if required) may be needed on the seabed and will be installed before and/or after foundation installation.

#### 6.1.2.2.1 Monopile Foundations

Seabed preparation for monopile foundations are usually minimal and typically limited to removal of boulders or other obstructions. Monopiles and transition pieces will be transported to the site on installation vessels or on dedicated transport vessels. Typical monopile construction activities include the following:

1. Monopile Delivery - Monopiles may be transported directly to the Wind Farm Area for construction or to the construction staging port. Monopiles (and transition pieces) are transported to site by an installation vessel or a feeder barge.
2. At the foundation location, the main installation vessel upends the monopile in a vertical position in the pile gripper mounted on the side of the vessel. The pile hammer is lifted on top of the pile to commence pile driving.
3. Pile Driving - Piles are driven until the target embedment depth is met, then the pile hammer is removed and the monopile is released from the pile gripper. After the monopile has reached its final position, the anode cage will be installed on the monopile. Pile driving during nighttime hours could potentially occur when a pile installation is started during daylight and, due to unforeseen circumstances, would need to be finished after dark. New piles could be initiated after dark to meet schedule requirements.
5. Transition Piece Installation - Once the monopile is installed to the target depth, the transition piece is lifted over the pile by the installation vessel. The transition piece comes fully fitted with boat fenders, access ladders, etc. It is also possible for the monopile and transition piece to be fabricated and installed as one component, with the boat landing and other ancillary features installed subsequently.
6. Grouting (or Bolting) - The joint between the monopile foundation and the transition piece may be cemented using grout, an inert cement mix. Grout is pumped from the installation vessel or another support vessel into the joint and carefully controlled and monitored to prevent loss of grout into the surrounding environment. Alternatively, the transition piece may be bolted to the monopile.
7. Completion - Once installation of the monopile and transition piece is complete, the vessel moves to the next installation location.
8. Scour Protection for Foundations - Several types of scour protection exist, including rock placement, mattress protection, sand bags, and stone bags. If scour protection is required, it encompasses the placement of large quantities of crushed rock around the base of the foundation structure is the most frequently used solution (rock placement). The rock placement scour protection solution may comprise a rock armor layer resting on a filter layer. The filter layer can either be installed before the foundation is installed (pre-installed) or afterwards (post-installed). Alternatively, by using heavier rock material with a wider gradation, it is possible to avoid using a filter layer and pre- or post-install a single layer of scour protection. The need for and amount of scour protection required will vary for the different foundation types being considered and based on the local site conditions. Flexibility in scour protection need and choice is required to accommodate changes in available technology and to allow for the most appropriate engineering solution within the design envelope and Project economics. The final choice as for the need for and detailed design of scour protection measures for the Project will be made after detailed design of the foundation structure, taking into account a range of aspects including geotechnical data, metocean data, water depth, foundation type, maintenance strategy, agency coordination, stakeholder concerns, and cost.

#### 6.1.2.2.2 Piled Jacket Foundations

The installation of piled jacket foundations is similar to monopiles, with structures transported to the site and lowered onto the seabed by the installation vessel. The pin piles can be installed either before or after the jacket is lowered to the seabed. The pin piles are driven into the seabed, similar to the monopile. Site

preparation would be similar to that of the preparation for monopiles, however it would require four times the preparation per turbine as for monopile.

If piles are installed first, a template (welded steel structure) is placed on the seabed to guide the pile locations. The piles are installed through the template. The jacket is lowered into position on the piles, and either welded or swaged to the piles.

If piles are installed after the jacket is lowered to the seabed, the piles will be installed through the jacket feet at the seabed or through the legs of the jacket from the top of the structure.

Installation vessels are described in Section 6.1.2.4.2.

### 6.1.2.3 *Scour Protection*

Scour protection is used to protect the offshore foundations from erosion of the seabed. The maximum area and volume of scour protection for each Project component is provided in Section 6.1.1. Scour protection for foundations, if required, may be placed pre- and post- installation. Methods of installation may include side stone dumping, fall pipe, or crane placement.

Side stone dumping uses a specialized vessel with a flat deck, which is loaded with stone, and mechanical shovels that push rock over the side. Anchors and winches are used for positioning. Side stone dumping may be used in water depths less than 164 ft. Fall pipe installation utilizes a fall pipe or string of buckets guided by a ROV to move rock from the installation vessel to the seabed.

### 6.1.2.4 *Turbines*

#### 6.1.2.4.1 General Turbine Installation

The main components of the turbine (tower, nacelle, and rotors) are expected to be manufactured in Europe and shipped across the Atlantic Ocean to the U.S. Once pre-assembly is complete, vessels in full compliance with the requirements of the Jones Act (46 U.S.C. § 883) will transport the nacelle-rotor assembly and towers to the Project site for installation

To support the offshore wind industry in the U.S., Orsted is investigating plans to develop an area at Hope Creek, NJ, adjacent to PSEG's nuclear facility, or in Norfolk, VA, into a WTG pre-assembly harbor. Either site, if developed, is expected to have utility that is broader than, and not constrained by, the Ocean Wind Project scope. The development of a WTG pre-assembly site at either Hope Creek or Norfolk is expected to be permitted independently from the Ocean Wind Project as such a site would have independent utility (the Ocean Wind Project can be developed without Hope Creek or Norfolk, and Hope Creek or Norfolk can be built without the Ocean Wind Project).

Generally, turbines will be installed using the following process:

- Turbine components are loaded onto barges, installation vessels or dedicated transport vessels.
- The barge, transport or installation vessel will travel to the Wind Farm Area.
- The crane on the installation vessel will lift the components onto the existing monopile foundation.
- Components will be fastened together as they are lifted into place.

#### **Pre-Assembly**

At the pre-assembly/load-out harbor, the WTG components will be pre-assembled, prepared for load-out and made ready for installation. The load-out harbor also functions as storage for WTG components, ensuring a constant supply to the installation vessel transiting between the offshore installation site and the load-out port.

The main pre-assembly activity, requiring the most resources, is tower assembly and outfitting. Incoming tower sections are inspected for overseas transport damage, and temporarily stored by means of purpose built heavy-duty tower lift-trucks.

When assembling the complete tower structure, the bottom tower section is upended from horizontal to vertical and bolted into a temporary tower stacking foundation near the quayside (**Figure 6.1.2-4** and **6.1.2-5**). Thereafter, middle section(s) are stacked and bolted on top, the service-lift is installed inside the complete structure, and multiple electrical connections are run for high voltage cable, communication, davit crane and nautical marking components. Certification work is carried out on certified structural elements and components. Pre-commissioning work prior to load-out includes applying identification-markings and a Quality Control (QC) walk-down with the owner's representative (see **Figure 6.1.2-6**).

Nacelles are unloaded at the pre-assembly harbor by means of multi wheelers or a harbor crane. A thorough inspection for overseas transport damage is conducted. Pre-assembly consists of mounting the Heli-hoist (basket), cooling unit with wind measurement instruments, and aviation marking components. If a nacelle is stored for a longer period, it needs to be conditioned by means of dehumidification and rotating of the entire drive train (e.g., generator). Prior to load out, the nacelle assembly is pre-commissioned, ID-markings applied, and a QC walk-down with the owner's representative is conducted (see **Figure 6.1.2-7**).

WTG blades are stored at the pre-assembly site as well, transported via harbor crane and trucks with special trailers. Little pre-assembly or inspection is required (see **Figure 6.1.2-8**).



**Figure 6.1.2-4. Upending of tower section in load-out port.**

Source: Gode Wind 2015.



**Figure 6.1.2-5. Towers assembled and ready at the load-out port.**

Source: Gode Wind 2015.



**Figure 6.1.2-6. Towers assembled and ready for load-out.**

Source: Gode Wind 2015.



**Figure 6.1.2-7. Nacelles pre-assembled and ready at load-out port.**

Source: Gode Wind 2015.



**Figure 6.1.2-8. Blades ready at load-out port.**

Source: Gode Wind 2015.

### **Wind turbine generator installation**

After pre-assembly of the WTGs, the WTG components (blades, nacelle, and tower) are loaded onto the Jones Act-compliant heavy lift installation and transportation vessel or other vessel, such as a barge. WTG components are fastened onto the deck of the installation vessel using specially-designed seaworthy fastenings. Once fully loaded, WTGs sets can be stored on board for transport and installation offshore (see **Figure 6.1.2-9**).

Once positioned at the offshore site, the installation vessel jacks-up and connects with a preinstalled foundation via gangway. Installation for each WTG is performed in five lifts; tower, nacelle, and three blades. This method of installing full towers and single blades from a dedicated installation vessel has proven to be an efficient and safe way to install WTGs offshore (see **Figure 6.1.2-10**).



**Figure 6.1.2-9. Loading towers onto installation vessel.**

Source: Gode Wind 2015.





**Figure 6.1.2-10. Installation of a WTG blade.**

Source: Borkum Riffgrund Wind Farm 1, 2014.

### Wind turbine generator commissioning

After installation, the WTG is connected to the grid and commissioned. Typically, the onshore substation will be energized and connected to the offshore substation, followed by the offshore substation, the array cables and finally the turbines. As described in Section 6.1.2.6.1, the array cables will typically be energized before burial and by the time the WTGs arrive on site to allow commissioning and the 240-hour run-test to be performed, as well as providing a back-feed to the WTG ancillary power supplies. If there is a delay in connecting a turbine to the grid, the turbines will need a back-up power supply until a connection can be made. A temporary backup diesel generator would be installed at the turbine until the connection is made.

Atlantic City will serve as the commissioning harbor and commissioning is included in the scope of the WTG supplier; however, commissioning would likely be completed by technicians hosted by either a CTV and/or dynamic position, or DP2, vessel with a “walk to work” access system (see **Figure 6.1.2-11**). The DP2 vessel uses a gangway system to transfer commissioning technicians to the WTGs and acts as a hotel vessel at the same time. CTVs push onto the boat landing on the foundations to allow technicians to ascend the WTG. WTGs typically begin producing power 1 to 4 days after installation has been completed.



**Figure 6.1.2-11. DP2 vessel and CTV.**

Source: Gode Wind 1 & 2, 2015.

Average installation period (including loading and transport) is expected to be up to 60 hours per turbine, of which the actual installation period is expected to be up to 24 hours per turbine. The total duration of installation of all turbines is expected to be approximately 12 months. Commissioning will follow installation.

#### 6.1.2.4.2 Vessels

Installation vessels will typically be a jack-up vessel to provide a stable platform when on site. It is anticipated that up to two jack-up vessels will be used. Jack-up barges towed by tugs may also be used. Where installation vessels are not used to transport the turbines to the installation site, dedicated transport, feeder barges, or jack-ups would be used for transport.

In addition, support vessels may be used including crew boats, hotel vessels, tugs, and other miscellaneous support vessels if needed (e.g., security vessels).

Where turbine installation and commissioning are occurring in the same area, up to eight vessels may be working simultaneously in 1.9 square miles.

**Table 6.1.2-1** provides the maximum number of vessels and the maximum number of trips to the Wind Farm Area from port that are anticipated throughout the turbine installation period. **Table 6.1.2-2** provides details on the type of vessels anticipated for turbine and foundation installation.

Construction vessels may refuel at sea due to multiday offshore operations. However, construction support vessels will not refuel at sea.

**Table 6.1.2-1. Wind turbine vessel trips.**

Vessel Type	Maximum Number of Simultaneous Vessels	Maximum Number of Round Trips Per Vessel Type
<b>Wind Turbine Foundation Installation</b>		
Scour Protection Vessel	1	50
Installation Vessel	4	99
Support Vessels	16	396
Transport / Feeder Vessels (including tugs)	40	396
- of which are anchored	2	198
<b>Structure Installation</b>		
Installation Vessels	2	99
Transport / Feeder Vessels	12	99
Other Support Vessels	24	594

**Table 6.1.2-2. Wind Turbine and Foundation Installation Vessel Details.**

Project Component	Vessel Details
Wind Turbine Installation	Installation Vessel: 145m long x 60m wide (not including helideck, crane); Displacement – 4,3000t
	Unpowered feeder barges: 125m long x 35m wide; Displacement – 21,000t
	Tug: 45m long x 15m wide
Foundations	Monopile installation: Floating Heavy Lift Vessel 240m x 50m, Displacement: 61,000T
	Offshore substation installation: Jack Up Vessel 140m x 40m, Displacement 8,000T
	Noise mitigation vessel: 90m x 20m, Displacement 4,900T

#### 6.1.2.5 Offshore Substations

Ocean Wind assumes that offshore substation supply and fabrication will be from an Asia-Pacific domiciled supplier. This assumption reflects alignment with a global supply chain that Orsted applies to its fleet of offshore wind farms, leveraging the most competitive fabrication tender prices from the present global market.

Offshore substations are generally installed in two phases, first the foundation substructure will be installed and then the topside structure will be installed on the foundation structure. The foundation substructure and topside structure may be transported to the site together or separately. An installation vessel will be used to lift the topside onto the pre-installed foundation substructure. Installation is expected to take up to two months per platform, not including cable pull-in, which is included in cable installation. The offshore substation topside and substructure components will be fabricated at a location to be determined, which is not planned to be in the State of New Jersey. Upon fabrication completion, the topside(s) will be sea transported to the site for installation (**Figure 6.1.2-12**). The transportation and installation vessels will be planned to ensure compliance

with the Jones Act. The installation window is expected to be 67 days or less for each offshore substation (topside and substructure).



**Figure 6.1.2-12. Installation of an offshore substation.**

Each substation is expected to require two primary installation vessels. Primary vessels may include self-propelled jack-up vessels, jack-up barges (towed by tugs), sheerleg barges (either self-propelled or towed by tugs), or Heavy-Lift Vessels. Up to 12 support vessels may be required including up to six tug boats, one dedicated leveling/dredging vessel, up to two crew boats, and up to two guard boats. In addition, transport vessels may be required. Alternatively, foundations and topsides could be transported on the installation vessel. The vessel requirements for substation installation are presented in **Table 6.1.2-3**.

**Table 6.1.2-3. Vessels required for substation installation.**

Parameter	Maximum Design Parameters	Maximum Return Trips per Vessel Type
Primary Installation Vessels	2	12
Support Vessels	11	72
Transport Vessels	4	24
Maximum Duration (days)	67	

If a monopile type foundation is used for the substructure, the installation of the substructure will follow the same procedure outlined above for WTG foundations and will be carried out by the same vessels used for the monopile/transition piece installation for WTGs.

An end-to-end commissioning schedule will be developed to ensure the safe operational function, performance and integration of the individual mechanical and electrical systems and associated communication signals on board the offshore substations. The commissioning phase is segregated into three discrete phases: Factory Acceptance Test, Site Acceptance Test, and Site Integration Test. Additionally, a series of off-load tests will be performed for first energization of high voltage equipment offshore. The method will be formalized in the FDR/FIR, will be reviewed by the CVA, and will be submitted to BOEM prior to construction. Typically, the onshore substation will be energized and connected to the offshore substation, followed by the offshore substation, the array cables and finally the turbines.

#### 6.1.2.6 Array Cables

Ocean Wind assumes that the array cables will be fabricated in the U.S., Europe or the Asia-Pacific region and shipped to a staging harbor in Port Elizabeth, New Jersey or Charleston, South Carolina unless transported directly to the Project site from the supplier. Depending on the array cable lengths, the array cables will be installed as either pre-cut sections, continuous lengths, or a combination of both. Array cables will be buried below the seabed where possible. As indicated in **Table 6.1.1-7**, the target burial depth will be 4 – 6 ft, though the final burial depth will be based on Cable Burial Risk Assessment.

Cable installation timing varies based on weather, sediment conditions and cable lay speed. **Table 6.1.2-4** provides an indicative estimate number of days for installation. This does not include mobilization, transit, port calls and down days.

**Table 6.1.2-4. Number of installation days for cable sections inshore and offshore.**

Cable Section	Estimated Number of Days
Oyster Creek (Inshore Cable)	56
Oyster Creek (Offshore Export Cable)	179
BL England (Offshore Export Cable)	26
Substation Interconnector Cable	13
Wind Farm Area (Array Cables)	112

Cables will typically be laid, and post-lay burial will be performed using a jetting tool, if seabed conditions allow. Cables may remain on the seabed within the Wind Farm Area for up to two weeks. Alternatively, the array cables may be simultaneously laid and buried. Array cables can be installed using a tool towed behind the installation vessel to simultaneously open the seabed and lay the cable, or by laying the cable and following with a tool to imbed the cable. Possible installation methods for these options include jetting, vertical injection, control flow excavation, trenching, and plowing. DP2 vessels with associated support craft will be used to install the array cables. The cables will either be loaded from the berth of the cable manufacturer or transported from the cable manufacturer to the designated load-out harbor. Interim storage for the cables may be required at the load-out harbor. The cable installation vessel loads the cables in batches. **Figure 6.1.2-13** provides an illustration of typical subsea cable being spooled from a factory or turntable. Post-lay burial of array cables is estimated to be performed at a rate of approximately 9.6 km per day (400 m per hour).

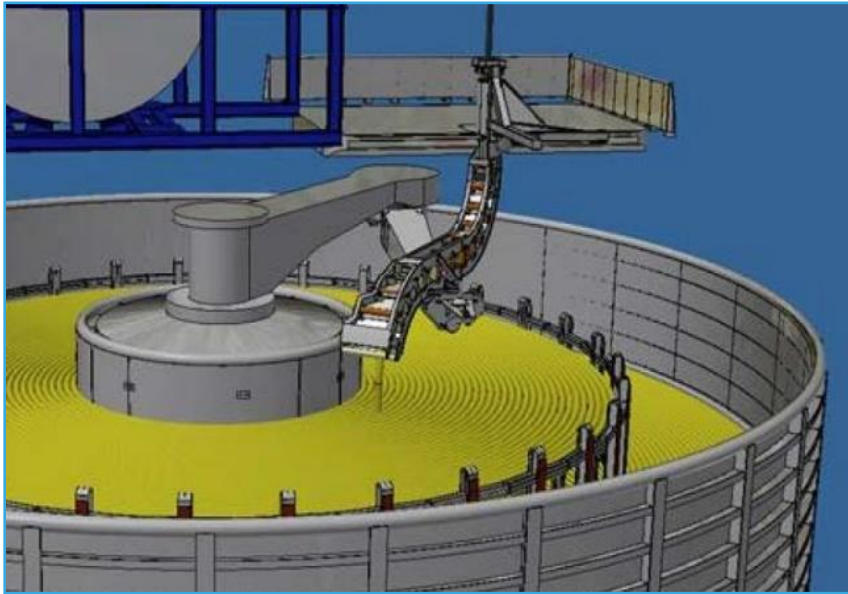

**Figure 6.1.2-13. Subsea cable being spooled from factory/quayside turntable.**

After load-out of the first batch of cable section(s) at the load-out port, the DP2 cable installation vessel will transit to the Wind Farm Area and commence cable installation of the first section of subsea cable in the direction of the offshore substation. At the offshore substation, a cable protection system is attached to the cable and the cable (pulling-head) will be pulled up by a winch through a dedicated J-tube onto the offshore substation cable deck, where it will be laid within the offshore substation cable management system. The following are steps in installing the cables.

#### 6.1.2.6.1 First-end pull

As described in Section 6.1.2.4.1, the array cables are typically pre-installed and terminated within the transition pieces before the WTGs are installed. The array strings may be energized before burial and by the time the WTGs arrive on site. This allows commissioning and the 240-hour run-test to be performed, as well as providing a back-feed to the WTG ancillary power supplies.

As the cable installation vessel approaches a foundation/transition piece, a winch wire is passed to the vessel. A cable protection system is attached to the cable and the cable is directly pulled to the termination point (see **Figure 6.1.2-14**).

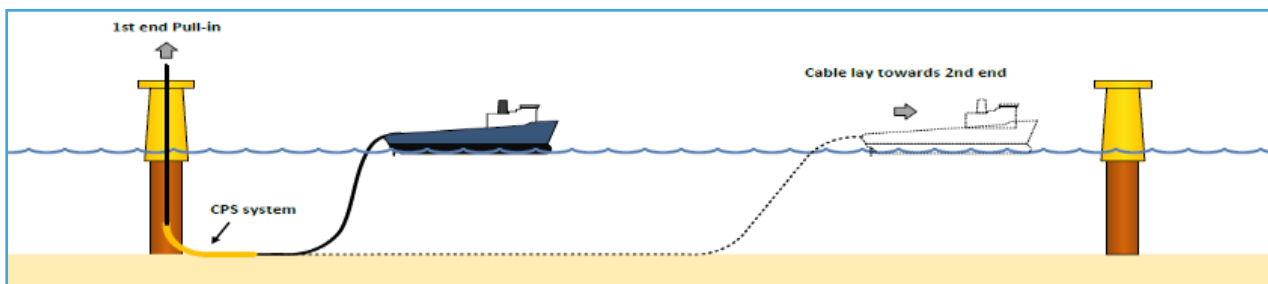

**Figure 6.1.2-14. First-end pull.**

#### 6.1.2.6.2 Second-end pull

The second-end pull requires a “quadrant” to be deployed. As the vessel approaches the foundation/transition piece, a winch wire will be passed to the vessel. A cable protection system is attached to the cable and the cable is deployed to the seabed on a quadrant. Once the cable reaches the termination point, the quadrant is tipped, and the cable is released to the seabed (see **Figure 6.1.2-15**). However, situations might arise that the foundation/ transition piece is not in place. In these cases, the cable end will be temporarily laid down on the seabed near the foundation location and the position recorded. After installation of the foundation/transition piece, the cable end will be recovered to the cable lay vessel and a second end pull in will be executed.

The cable second end will be sufficiently sealed and equipped with recovery rigging in order to be temporarily laid to seabed, until such time as the monopile is installed to enable pull in.

The cable and termination will be temporarily laid to a pre-determined corridor, away from the proposed monopile. A full subsequent as laid survey will then be carried out in order to provide detailed information of the cable route and to enable the monopile installation.

The cable will be recovered for future pull in, by utilizing a winch wire from the installation vessel and attaching to the pre-installed cable recovery rigging. The cable will be hauled to deck and placed within the cable tensioner, whereby a suitable length will be recovered in order to enable the final lay and pull in to the monopile, utilizing a quadrant setup.

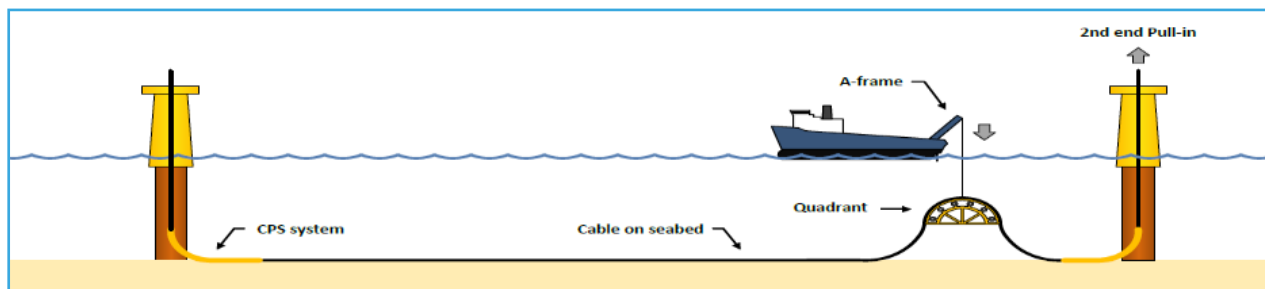

**Figure 6.1.2-15. Second-end pull.**

Surveys will be conducted to locate any third-party infrastructure, such as existing cables, that will need to be crossed. If array cables must cross third party infrastructure, the cable will be laid, and post-lay burial or post-lay protection will occur to allow for protection of both the existing infrastructure and the cable installed. This protection typically consists of a separation layer on the existing cable (usually a rock berm) as well as a protection layer on the array cable. These are described below. Ocean Wind would work with the owner of the existing infrastructure to develop a crossing agreement.

#### 6.1.2.6.3 Cable Protection

Cable protection may be required where burial cannot occur, sufficient depth cannot be achieved, or protection is required due to crossing other cables or pipelines. Rock placement, mattresses, frond mattresses, rock bags, or seabed spacers may be used to protect the cable.

##### **Rock Placement**

Rocks of different grade sizes are placed from a fall pipe vessel over the cable. Initially smaller stones are placed over the cable as a covering layer to protect the cable from larger rocks, followed by larger rocks.

The rocks generally form a trapezoid, up to 4.9 feet above the seabed with a 2:1 gradient. This may vary depending on expected scour. The trapezoid shape is designed to protect against anchor drag as well as

anchor drop. The length of the protection depends on the length of cable that is not buried or has not achieved target depth. Where rock placement is used for crossing another cable or utility, a separation layer may be laid on the seabed before rock placement.

### **Mattress Placement**

Mattresses generally have dimensions of 19.7 ft by 9.8 ft by 1 foot. They are formed by interweaving a number of concrete blocks with rope and wire. They are lowered to the seabed on a frame. Once positioning over the cable has been confirmed, the frame release mechanism is triggered, and the mattress is deployed. The mattress placement process is repeated over the length of cable that requires additional protection. Mattresses provide protection from anchor drop but are less effective at protecting against anchor drag. Where mattresses are used for crossing another cable or utility, a separation layer must be laid on the seabed before mattress placement.

### **FronD Mattress Placement**

FronD mattresses are designed to mimic natural seagrass and promote the formation of protective, localized sand berms. Buoyant fronds are built into the mattress and when deployed they float in the water column trapping sand. FronD mattresses are installed following the same procedure as general mattress placement. The fronds floating in the water column can impede the correct placement of additional mattresses.

### **Rock Bags**

Rock bags consist of various sized rocks constrained within a rope or wire netting containment. They are placed using a crane and deployed to the seabed in the correct position. Rock bags are more appropriate for cable stability or trench scour related issues.

### **Seabed Spacers**

Seabed spacers consist of plastic or metal half shell sections that are bolted together to form a circular protection barrier around the cable as the cable is installed. Because they must be installed during installation, they are only used at areas where it is known burial will not be achieved, such as crossings or rock areas. Rock may be placed on top to provide additional protection from anchors or fishing gear.

#### **6.1.2.6.4 Post-installation survey**

When the cable has been installed, post cable-lay surveys and depth-of-burial surveys will be carried out to determine whether the cable has reached desired depth. Remedial protection measures such as rock or mattress placement may be required if the target burial depth is not met.

#### **6.1.2.6.5 Vessels**

During construction, a few different primary ports may be used (See Section 4.1.1). Installation vessels for array cable installation include main laying vessels and burial vessels in addition to support vessels. Main laying and burial vessels could include barges or DPs, each with three associated anchor handling tugs. Anchoring will occur every 1,640 ft, also known as the anchor position spacing. Each main vessel will have up to eight anchors spaced 984 to 1,640 ft from the vessel. Support vessels will be required including crew boats, service vessels for pre-rigging foundations with cable, and vessels for divers, pre-lay grapnel run, and post lay inspection. **Table 6.1.2-5** provides the vessel information for array cable installation. **Table 6.1.2-6** provides details on the type of vessels anticipated for array cable installation.



**Table 6.1.2-5. Vessels required for array cable installation.**

Parameter	Maximum Number of Simultaneous Vessels	Maximum Number of Return Trips per Vessel Type
Main Laying Vessels	3	99
Main Burial Vessels	3	99
Support Vessels	12	594
Duration per cable section (days)	-	3.5
Total Duration (months)	-	12

**Table 6.1.2-6. Array cable installation vessel details**

Construction Activity	Vessel Type
<b>Array Cable Installation – Primary Array Cable Installation Vessels</b>	
Array Cable Lay	Approx. Length: 140m; Beam: 30m; Deadweight: 10,000Te
Trenching Support	Approx. Length: 100m; Beam: 30m; Displacement: 12,200Te
<b>Array Cable Installation– Secondary Support Vessels</b>	
Pre-lay Grapnel Runs	Approx. Length: 70m; Beam: 20m; Gross tonnage: 1,660 ITC
Boulder removal	Approx. Length: 95m; Beam: 20m; Deadweight: 3,285 LT
Survey	Approx. Length: 50m; Beam: 12m; Gross tonnage: 615 GT
Crew Transport Vessel	Approx. Length: 30m; Beam: 11m; Gross tonnage: 235 GT
Crew transfer and accommodation	Approx. Length: 90m; Beam: 20m; Deadweight: 4,870 LT
Rock Installation	Approx. Length: 160m; Beam: 36m; Cargo: 24,000Te

**6.1.2.7 Substation Interconnection Cables**

Installation of the substation interconnection cables will be as described for the array cables in Section 6.1.2.6 or the offshore export cables in Section 6.1.2.8. Vessels required for substation interconnection cable installation are provided in **Table 6.1.2-7**.

**Table 6.1.2-7. Vessels required for substation interconnection cable installation.**

Parameter	Maximum Number of Simultaneous Vessels	Maximum Number of Return Trips per Vessel Type
Main Laying Vessels	Included in numbers for export and array cables	8
Main Burial Vessels		8
Support Vessels		12
Duration: per cable (days)		20
Duration: total (months)		1

The number of days expected to be required to install the substation interconnection cables are shown in **Table 6.1.2-4**.

**6.1.2.8 Offshore Export Cables**

Ocean Wind assumes that the onshore and offshore export cables will be fabricated in Europe, the U.S., or from the Asia-Pacific region, and shipped to a staging harbor in Port Elizabeth, New Jersey or Charleston, South Carolina unless transported directly to the Project site from the supplier. From this port, installation vessels will load the cable turntables for transport and installation at the Wind Farm Area.

The cables will be spooled on to the installation vessel in sections, as may be dictated by the vessel's turntable capacity or the specified cable design length (e.g., to accommodate an offshore field-joint at a particular location). The cable installation vessel will transport cable from the load-out port to the barge in the nearshore section.

Offshore export cables would typically be buried below the seabed. The offshore export cable installation area will be prepared, and cables will be installed in a similar manner described in Section 6.1.2.6 for array cables. The installation vessel will transit to and take position at the landfall location and the cable end will be pulled into the preinstalled duct ending in the TJB. The installation vessel will transit the route toward the offshore substation, installing the cable by simultaneous lay and burial (plow/jetting/cutting) or surface lay and burial by a cable burial vessel (jetting/cutting/control flow excavation). It is anticipated that approximately 1 to 3 miles of cable would be installed per day during active installation. The offshore export cables are broken into sections for installation purposes and the length of these sections are determined by the weight or volume capacity of the installation vessels carrying the cable. Where offshore joints or termination at an offshore substation occur, up to 328 yards of cable may remain on the seabed until the foundation is installed or the next cable section is available for installation or jointing. For offshore joints along the export cable route, transponders will be affixed to the end of the cable and the cable will remain on the seabed, to allow the installation vessel to reload for the new cable section and return to the site, after which the joint will be made, the cable will be buried, and installation of the next section of cable will continue. In the case that the cable installation sequence does not allow for immediate jointing, and a significant increase of time is expected between laydown and jointing, then exposed cable ends will be temporarily buried and later recovered prior to jointing process. Where offshore substation foundations are not ready, the cable will remain on the seabed until the substation foundation is ready for a second end pull in. In the unlikely event of unanticipated emergency weather conditions during installation, the cable may be cut, sealed and lowered to the seabed to allow the vessel and crew to seek safety.

Installation vessels for offshore export cable installation include main laying vessels, jointing vessels, and burial vessels in addition to support vessels. Main laying and burial vessels could include barges or DPs, each with three associated anchor handling tugs. Main jointing vessels include barges, DPs, and jack-up vessels, each with three associated anchor handling tugs. Anchoring will occur every 1,640 ft, also known as the anchor position spacing. Each main vessel will have up to eight anchors spaced 984 to 1,640 ft from the vessel.

Support vessels will be required including crew boats, service vessels for pre-rigging platforms with cable, and vessels for divers, pre-lay grapnel run, leveling, and survey.

Protection measures will also be installed as described above for array cables as per Section 6.1.2.6.3. A cable protection system will be implemented during cable installation. The ends of the cable will be pulled into the TJB and the offshore substation cable deck. The number of days expected to be required to install the offshore export cables are shown in **Table 6.1.2-4**. It is estimated that the simultaneous lay and bury lay speed of the offshore export cables will be approximately 3 km per day (125 km per hour). This is an average speed which is driven by the requirement for the vessel to stop to perform anchor resets. Construction activities such as HDD and offshore substation pull-ins and crossings will be multi day operations and are lower than the average daily rate.

**Table 6.1.2-8** provides the vessel information for offshore export cable installation. **Table 6.1.2-9** provides details on the type of vessels anticipated for offshore export cable installation.

**Table 6.1.2-8. Vessels required for offshore export cable installation.**

Parameter	Maximum Design Parameters	Maximum Number of Return Trips per vessel type
Main Cable Laying Vessels	3	48
Main Cable Jointing Vessels	3	36
Main Cable Burial Vessels	3	48
Support Vessels	15	72
Duration per cable section (days)	-	59
Typical Duration (months)	-	6

**Table 6.1.2-9. Offshore export cable installation vessel details.**

Construction Activity	Vessel Type
<b>Export Cable Installation</b>	
Export Cable Lay (offshore)	Approx. Length: 130m; Beam: 30m; Deadweight: 10,800Te
Trenching Support	Approx. Length: 100m; Beam: 20m; Deadweight: 3,000Te
Export Cable Lay (inshore)	Approx. Length: 125; Beam: 35m; Depth: 8m Plus Anchor handler support vessels
<b>Export Cable Installation – Secondary Support Vessels</b>	
Pre-lay Grapnel Runs, Boulder Removal, Mattressing, Surveys	Approx. Length: 80m; Beam: 20m; Gross: 2,400 GT
Survey	Approx. Length: 50 m; Beam: 10m; Gross 615 GT
Anchor Handling Tug	Approx. Length: 30m; Beam: 15m; Gross: 345 GT
Rock Installation	Approx. Length: 160m; Beam: 40m; Cargo: 24,000Te
Crew Transport Vessel	Approx. Length: 27m; Beam: 11m; Gross: 235 GT

### 6.1.3 Construction and Operation Surveys

Ocean Wind is planning on conducting construction and post-construction HRG surveys. Pre-construction geotechnical surveys are described in the survey plan currently under BOEM's review. At this time no construction or post-construction geotechnical surveys are planned. However, if geotechnical surveys are needed Ocean Wind will develop a survey plan for BOEM review.

While the final survey plans will not be completed until construction contracting commences, Ocean Wind assumes that HRG survey operations during construction would be conducted 24 hours per day, with an assumed daily average survey distance of 70 km. Up to three vessels may be working concurrently within a 24-hour period and would generally conduct survey effort at a transit speed of approximately 4 knots, which equates to 110 km per 24-hr period. However, based on past survey experience (i.e., knowledge of typical daily downtime due to weather, system malfunctions, etc.), Ocean Wind assumes 70 km as the average daily distance. On this basis, an annual total of 88 survey days (approximately 47.5 survey days in the Offshore Wind Farm and 40.5 survey days in the export cable route area) is expected during Years 1, 4, and 5.

Some inter-year variance in survey locations may be expected, however, 88 survey days annually is anticipated to be required regardless of location. It is estimated that a total of 6,110-linear kilometers (km) will be needed within the Offshore Wind Farm and export cable route area. Survey effort will be split between the Offshore Wind Farm and the ECR area: 3,000 km for the array cable, 2,300 km for the Oyster Creek export cable, 510 km for the BL England export cable, and 300 km for the offshore substation interconnector cable.

During WTG and offshore substation construction and operation, it is anticipated that up to 180 survey days per year will be required, which includes up to 11,000 km of export cable surveys, 10,500 km of array cable surveys, 1,065 km of foundation surveys, 250 km of WTG surveys, and up to 2,450 km of monitoring and verification surveys. In certain shallow-water areas, vessels may conduct surveys during daylight hours only, with a corresponding assumption that the daily survey distance would be halved (35 km). However, for purposes of analysis, a single vessel survey day is assumed to cover the maximum 70 km. Multiple vessels may conduct HRG surveys simultaneously.

#### 6.1.4 Operation and Maintenance

This section provides a description of the reasonably foreseeable planned and unplanned maintenance activities for the Project. The Project is anticipated to have an operational life of 35 years. Per the Lease, the operations term of the Project is 25 years and will commence on the date of COP approval. It is anticipated that Ocean Wind will request to extend the operations term in accordance with applicable regulations in 30 CFR § 585.235.

Maintenance activities will include both preventive and corrective maintenance. Preventive maintenance will be undertaken in accordance with scheduled services whereas corrective maintenance covers unexpected or emergency repairs, component replacements, retrofit programs, and breakdowns.

Ocean Wind will conduct surveys of foundations, bathymetry, scour (and associated scour protection if deployed), and cable burial. The total inspections anticipated over the life of the Project are presented in **Table 6.1.4-1**.

An onshore O&M facility in or near Atlantic City will be used and this facility may serve multiple projects, therefore is not a specific part of the Project. The O&M facility is discussed in Section 6.2.3.1. Multiple types of vessels will be required for O&M activities, as discussed in Section 6.1.3.5.

The maximum Operation and Maintenance activities projected over the life of the Project are summarized in **Tables 6.1.4-2** through **6.1.4-5**. Actual activities may be less. Vessel trips associated with Operation and Maintenance activities are provided in **Table 6.1.2-6**.

**Table 6.1.4-1. Total Project offshore surveys of foundations, bathymetry, scour protection and cable burial.**

Facility	Activity	Maximum
All Offshore Facilities	Seabed Surveys - for Bathymetry, Cable Burial Depth, Scour during Project lifetime (events)	38

##### 6.1.4.1 Turbine Foundation and Substation Foundation Maintenance Activities

Foundation maintenance is anticipated for offshore wind turbines and substations. Ocean Wind will conduct inspections of foundations, bathymetry, scour (and associated scour protection if deployed), and cable burial. Multibeam echosounder (MBES) surveys are planned to be conducted during Years 1, 4, and 5 post-commissioning. Subsequently, an optimal survey frequency will be determined based on initial findings. Sonar, remotely operated vehicles, drones, and divers may be required. Depending on the inspection, follow up maintenance will be performed as needed and may include cleaning (e.g., periodic cleaning of guano or marine growth on access ladders), painting, or replacement of access ladders, anodes or J-tubes, as summarized in **Table 6.1.4-7**. Vessels will be used for each type of maintenance to transport crew and materials. Jack-up vessels will be required for ladder replacement, anode replacement, and J-tube replacement.

Each subsea foundation component will be cleaned of organic build-up as needed. Marine growth and guano will be physically brushed off turbines to break down build-up where required, followed by a high pressure wash. Divers may be required.

Painting will be required at each foundation to protect against corrosion. Offshore turbine foundations may be fully painted every ten years and may require touch-up paint every three years. Substation foundations will require one full paint job during the life of the Project. It is anticipated that technicians and equipment—largely hand tools—will be deployed from a CTV or similar vessel. Surface preparation is required to break down existing surface coatings and any associated corrosion prior to painting.

Access ladders may need to be replaced due to corrosion or damage.

Anodes are highly active metals which are attached to less active metals to attract the electrolytes that would normally corrode and weaken the less active metal. Anodes required for corrosion protection would be aluminum or similar reactive metal, which corrodes preferentially, protecting the steel of the turbine or substation foundation. Anode replacements are likely to be conducted by divers from a dive support vessel.

J-tubes are used to protect cables at the WTGs and offshore substations from the power of the sea as the cables transition from the foundation to upper parts of the WTG or substation. J-tubes may require modifications or corrective maintenance, including alterations to the bell mouth of the J-tubes during cable repair or replacement. This may include cutting and re-welding. J-tube repair or replacement would be conducted by divers from a diver support vessel or using a jack-up vessel.

If needed, concrete crack repairs (external work on platform or transition piece) will occur. This would include grinding and cutting in concrete, and application of cement mortar and/or epoxy based resins.

**Table 6.1.4-2. Offshore foundation operation and maintenance activities.**

Facility	Activity	Maximum *
Wind Turbine Foundations	Repainting (events)	347
	Cleaning (guano removal) (events)	17,325
	Access Ladder Replacement (events)	693
	Anode Replacement (events)	693
	J-tube Replacement (events)	198
	Concrete Crack Repairs (events)	99
Offshore Substations	Repainting (events)	3
	Cleaning (guano removal) (events)	525
	Access Ladder Replacement (events)	21
	Anode Replacement (events)	21
	J-tube Replacement (events)	6

\* Maximum events for the entire Project over the life of the Project. Actual events may be less.

**6.1.4.2 Turbine Maintenance Activities**

Routine operation and maintenance activities for the offshore wind turbines include annual and periodic maintenance. Annual maintenance includes routine service, safety surveys and checks, oil and HV maintenance, and blade maintenance, as well as painting, cleaning and ladder replacement as described above. In addition, major overhauls are expected every five to seven years. Fault rectification will take place on a rolling basis and it is assumed that there will be up to ten per year per turbine (extreme case).

Additionally, major component replacement (e.g., wind turbine blades, blade bearings, hub generators, yaw rings, or nacelles) is expected over the life of the Project as listed in **Table 6.1.2-8**. A suitable jack-up vessel and crew boat, like those used during installation, will be required. A second jack-up vessel might be necessary acting as feeder vessel. Visits may increase towards the end of the Project life or if the lifetime is extended. Jack-up operations outside the lease area might be necessary for some of the positions.

**Table 6.1.4-3. Total WTG operation and maintenance activities.**

Facility	Activity	Maximum
Wind Turbines	Major Component Replacement (events)	966

#### 6.1.4.3 Offshore Substation Operation and Maintenance Activities

Each electrical plant will be routinely maintained for preventative maintenance up to 12 times per year. Electrical inspections will be undertaken up to twice per year at each item of plant and scheduled maintenance may occur annually. Minor fault rectification is anticipated at each plant up to ten times per year. Vessels are expected to be required for each type of maintenance to transport crew and materials.

In addition to routine activities, major component replacements are anticipated at each substation over the life of the Project as listed in **Table 6.1.2-9**. Jack-up vessels for corrective maintenance are anticipated to be required for these activities.

**Table 6.1.4-4. Total Project offshore substation operation and maintenance activities.**

Facility	Activity	Maximum
Offshore Substations	Major Faults/Component Replacements (events)	6

#### 6.1.4.4 Cable Maintenance Activities

The offshore export cables, inter-array cables, and offshore substation interconnector cables typically have no maintenance requirements unless a fault or failure occurs. Cable failures are mainly anticipated as a result of damage from external influences, such as anchors and fishing gear. To evaluate integrity of the cables, Ocean Wind intends to conduct a multibeam echosounder (MBES) bathymetry survey along the entirety of the cable routes immediately following installation (scope of installation contractor), and during Years 1, 4, and 5 after commissioning. Survey frequency thereafter will depend on the findings of the initial surveys (i.e., site seabed dynamics and soil conditions). Additional surveys may be conducted as needed, such as after a major storm event (i.e., greater than 10-year event). Surveys of the cables may be conducted in coordination with scour surveys at the foundations. Vessels will be used to transport crew and materials. Sonar, remotely operated vehicles and related equipment, drones, and divers may be required. Jack-up vessels may be required for cable recovery/repairs within 656 ft (200 m) of the offshore substations and WTGs.

Portions of the cables are expected to become exposed due to natural sediment transport processes and are expected to require scour protection replenishment or reburial. In addition, seabed disturbance would be required associated with repair of cable faults. **Table 6.1.2-5** provides maximum anticipated reburial and faults, as well as estimates for associated jetting, seabed disturbance, and rock placement. Following reburial, survey will be conducted to determine the success of reburial.

Cable faults are expected to occur over the life of the project. Faults would be detected by the wind farm protection system and would require location testing using remote diagnostic testing to identify the exact location along the cable length. Where a fault is detected, cable will be exposed and repaired or replaced. A

new section of cable will be jointed aboard the cable handling vessel. Upon completion of the repair, the cable will be lowered onto the seabed and assessed to determine whether it is on or as close as practicable to the original cable/trench location. Reburial by a jetting tool is expected. Post-burial survey would be completed to determine the success of burial.

Cable maintenance duration typically lasts up to three months including mobilization, survey, exposing the cable, recovery, repair, re-burial, and post-lay survey, however this could be longer due to weather.

Maximum parameters for cable O&M are provided in **Table 6.1.4-5**. Ocean Wind is also developing a cable monitoring and maintenance plan which will be included in the FDR and reviewed by the CVA.

**Table 6.1.4-5. Total Project offshore cable operation and maintenance activities.**

Facility	Activity	Maximum *
Array Cable	Remedial Burial for the life of the Project (miles)	13
	Jetting Remedial Burial - Length per event (miles)	1.24
	Jetting Remedial Burial - Width per event (feet)	328
	Jetting Remedial Burial - Seabed disturbance area (acres per event)	49.4
	Cable Faults (number of events)	6
	Cable Faults - Seabed disturbance area per event (acres)	4.9
	Cable Faults - Rock berm area per event (acres)	1.5
	Cable Faults - Rock berm volume per event (cubic yards)	8,800
Substation Interconnector Cables	Remedial Burial for the life of the Project (miles)	1.9
	Jetting Remedial Burial - Length per event (miles)	1.2
	Jetting Remedial Burial - Width per event (feet)	328
	Jetting Remedial Burial - Seabed disturbance area (acres per event)	49.4
	Cable Faults (number of events)	2
	Cable Faults - Seabed disturbance area per event (acres)	4.9
	Cable Faults - Rock berm area per event (acres)	1.5
	Cable Faults - Rock berm volume per event (cubic yards)	8,800
Offshore Export Cables	Jetting Remedial Burial - Length per event (miles)	1.24
	Jetting Remedial Burial - Width per event (feet)	328
	Jetting Remedial Burial - Seabed disturbance area (acres per event)	49.4
	Cable Faults - Seabed disturbance area per event (acres)	4.9
	Cable Faults - Rock berm area per event (acres)	1.5
	Cable Faults - Rock berm volume per event (cubic yards)	8,800
Oyster Creek Export Cables	Remedial Burial for the life of the Project (miles)	3.1
	Cable Faults (number of events)	13
BL England Export Cables	Remedial Burial for the life of the Project (miles)	1.2
	Cable Faults (number of events)	3

\* Maximum events for the entire Project over the life of the Project. Actual events may be less.

**6.1.4.5 Operation and Maintenance Vessels**

Multiple types of vessels will be required for the O&M activities described above. Annual vessel trips for O&M are summarized in **Table 6.1.2-6**. The Project will use a variety of vessels to support O&M, including CTVs, Service Operation Vessels (SOVs), jack-up vessels, and crew and supply vessels. The type and number of vessels will vary over the operational lifetime of the Project. For each vessel type, the route plan for the vessel operation area will be developed to meet industry guidelines and best practices in accordance with International Chamber of Shipping guidelines. The Project will require operational Automatic Identification Systems (AIS) on all vessels associated with the construction, operation, and decommissioning of the Project, pursuant to USCG and AIS carriage requirements. AIS will be required to monitor the number of vessels and traffic patterns for analysis and compliance with vessel speed requirements. All vessels will operate in accordance with applicable rules and regulations for maritime operation within U.S. and federal waters. Similarly, all aviation operations, including flying routes and altitude, will be aligned with relevant stakeholders including FAA. Additionally, the Project will adhere to vessel speed restrictions as appropriate in accordance with NOAA requirements.

CTVs or Surface Effect Ships (SES) would be required and would be active daily except in severe weather. Compared to conventional CTVs, SES are high-speed crew transfer air-cushion catamarans that provide a combination of high speed and excellent seakeeping for offshore wind farm operation.

In addition, SOVs built for accommodation and motion compensated gangway transfer of technicians to offshore assets would be required. SOVs would typically be used seasonally; however, extended operation would be possible.

Jack-up vessels are mobile platforms that consist of a buoyant hull, that allows the vessel to be easily transported, and legs capable of raising the hull above the sea surface. **Table 6.1.2-7** provides operations jack-up vessel parameters.

Drones and autonomous underwater vehicles may be used for a number of activities associated with O&M. These technologies will be used for inspection of the Ocean Wind assets (i.e., for blade inspection, underwater foundation inspection, and seabed surveys). As these technologies are constantly evolving and maturing, they could also be potentially used for light logistics in the future.

**Table 6.1.4-6. Offshore operation and maintenance vessel summary of maximum annual visits.**

Vessel Type	Maximum Number of Trips per year
Jack-Up Vessels	102
Crew Vessels	908
Supply Vessels	104

**Table 6.1.4-7. Operations jack-up and anchored vessel parameters.**

Parameter	Maximum Design Parameters
Number of jack-up vessel legs	6
Area of each leg base at the seabed (ft <sup>2</sup> )	1,830
Anchored vessel - anchor dimensions (ft)	32.8 x 32.8
Anchored vessel - number of anchors per vessel	8



### 6.1.5 Non-routine Activities

Non-routine activities include items such as corrective maintenance or unscheduled repairs. These maintenance activities can be in response to equipment performance, natural phenomenon (e.g., severe storms or other natural disaster), or other unanticipated events. Ocean Wind will strive to minimize the need for non-routine activities through a Project preventative maintenance program, however unscheduled maintenance and repairs will be necessary during the operation of the Project.

Corrective maintenance is required on an as-needed basis and therefore difficult to estimate and quantify, and for this reason proper preparation is imperative. Ocean Wind will implement corrective maintenance as needed based on the availability of the key items such as spare parts, workforce, or site accessibility. Corrective action may be delayed due to one or more of these items. Ocean Wind will strive to minimize these delays through proper planning and regularly scheduled maintenance.

#### 6.1.5.1 *Spare Parts*

Ocean Wind will maintain recommended stocks of spare parts for key Project components to mitigate potential downtime from necessary corrective maintenance. Stocks of spare parts and key Project components will be based on original equipment manufacturer (OEM) recommendations, reliability of the components and Orsted experience.

As part of the Project maintenance program, Ocean Wind will monitor the use of corrective maintenance stocks and purchase additional stocks to maintain recommended levels. Spare parts for corrective maintenance may be stored at the Project maintenance facilities, Ocean Wind facilities, OEM facilities, or other storage facilities as appropriate.

#### 6.1.5.2 *Workforce*

In the event that staff from the Ocean Wind maintenance staff are unavailable or unqualified to complete a necessary repair (e.g., major WTG repairs, offshore substation platform repairs, or export cable repairs), Ocean Wind may be required to hire workers to complete the corrective maintenance. These workers could be from local workforces (i.e., labor unions or general contractors) or from international repair teams if the local workforce is not equipped to execute the necessary corrective maintenance. Ocean Wind will utilize a trained maintenance staff and corrective maintenance may be delayed or contingent upon availability of appropriately skilled workers.

#### 6.1.5.3 *Site Accessibility*

In the event that maintenance cannot be addressed remotely, such as through the remote monitoring systems, corrective maintenance crews may be required to access the Project site to complete the necessary maintenance. Maintenance activities for the Project will be coordinated with Orsted's Health and Safety Protocols to provide the safest working conditions for workers completing corrective actions.

## 6.2 Onshore Infrastructure and Activities

The following sections provide a description of construction and installation, O&M, and non-routine activities for onshore components of the Project. During the development of the onshore export cable routes and onshore substation a number of surveys will be carried out, including ground penetrating radar, service and utility searches and geotechnical investigation. These surveys are required to assist with the design of the substation and onshore export cable routes.

## 6.2.1 Project Components

### 6.2.1.1 Onshore Export Cable

Onshore cables will connect with offshore cables at TJBs, as described for cable landfall in Section 6.2.2.1, and carry electricity to the substation. Each three-core submarine cable will be separated and spliced into three separate single-core cables within the TJBs. Each of these single-core cables comprise a single circuit of the onshore transmission cable system. The cables will consist of copper or aluminum conductors wrapped with materials for insulation protection and sealing. From the TJB the onshore transmission cable system will be contained within an underground duct bank to the new proposed onshore substation.

Onshore cables would be buried and housed within one duct bank, which would require a construction corridor and a smaller permanent easement as shown in **Table 6.2.1-1**. This table provides maximum design parameters for onshore export cables which will be finalized during the design phase as available land and engineering constraints are better defined.

**Table 6.2.1-1. Onshore export cable parameters.**

Parameter	Maximum Design Parameters
Type of cable	XLPE, FF Copper and Aluminum
Diameter of cable (inches)	8
Diameter of cable ducts (inches)	13
Maximum voltage (kV)	275
Target burial depth (ft)	4*
<b>Construction Areas and Volumes</b>	
<b>Oyster Creek</b>	
Length of onshore cable route (miles)	5.3
Cable trenches	2
Total onshore cables	6
Corridor width - permanent (ft)	30
Corridor width - temporary and permanent used for construction (ft)	50
Corridor area - permanent (acres)	19
Corridor area - temporary and permanent used for construction (acres)	32
Number of joint bays	34
Joint bays total area (acres)	2
Joint bays spoil volume per pit (cubic yards)	3,000
Joint bays spoil total volume (cubic yards)	97,200
Link bays total area (acres)	0.03
Link bays spoil volume per pit (cubic yards)	9
Link bays spoil total volume (cubic yards)	311
Utility bridge length (ft)	200
Utility bridge height and width (ft)	10
<b>BL England</b>	
Length of onshore cable route (miles)	8
Cable trenches	1
Total onshore cables	3
Corridor width - permanent (ft)	30

Parameter	Maximum Design Parameters
Corridor width - temporary and permanent used for construction (ft)	50
Corridor area - permanent (acres)	29
Corridor area - temporary and permanent used for construction (acres)	48
Number of joint bays	26
Joint bays total area (acres)	1.5
Joint bays spoil volume per pit (cubic yards)	3,000
Joint bays spoil total volume (cubic yards)	19,000
Link bays total area (acres)	0.02
Link bays spoil volume per pit (cubic yards)	9
Link bays spoil total volume (cubic yards)	55

\* Burial depth is target burial rather than maximum burial depth.

The duct bank would be concrete-encased and use six polyvinyl chloride (PVC) conduits for the power cables. The ducts will be arranged in a 3x4 orientation. There will also be two PVC conduits for fiber optic communications cables and two PVC conduits for ground continuity conductors (GCCs). The circuits will be housed within this single duct bank and there is currently no plan for spare conduits. **Figure 6.2.1-1** shows the proposed concrete-encased duct bank cross-section.

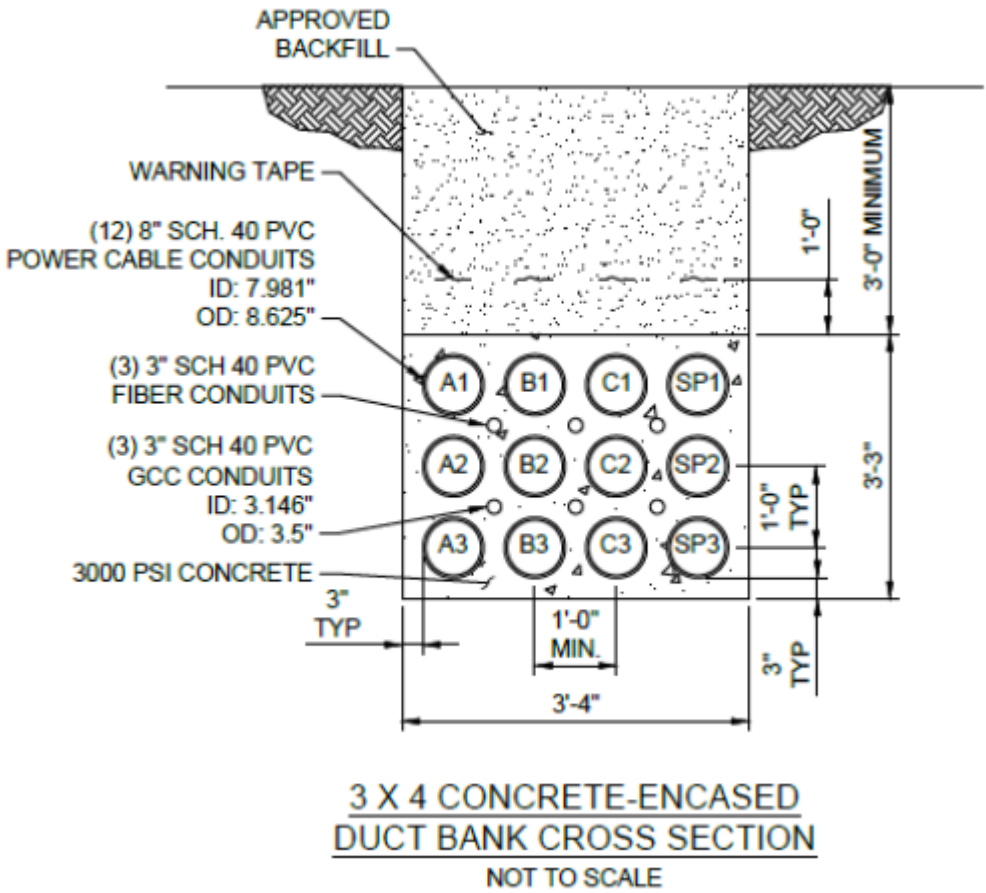
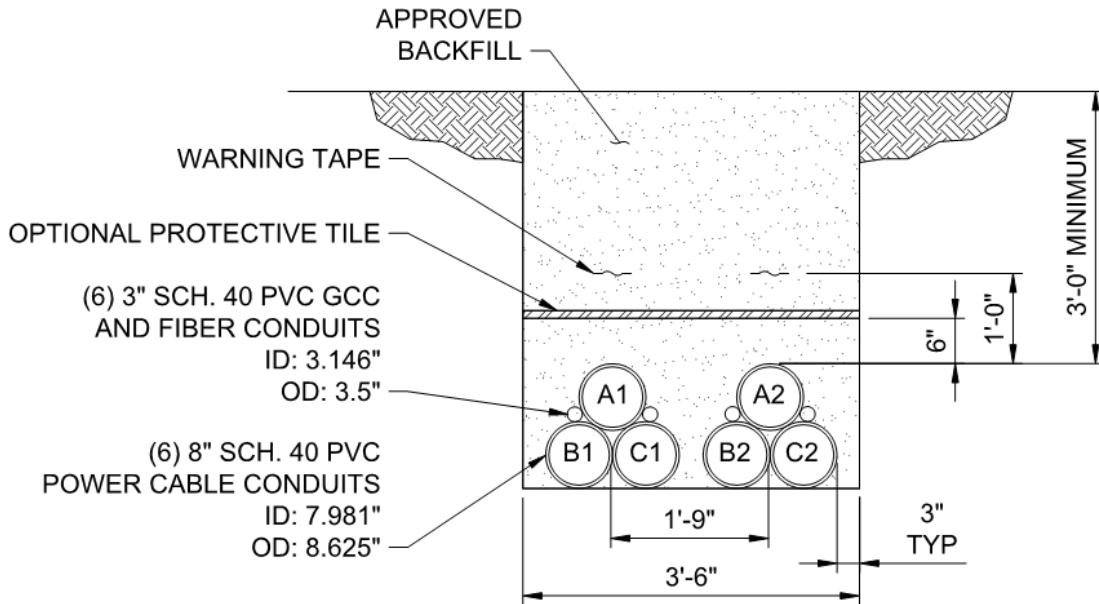

Figure 6.2.1-1. Typical concrete-encased duct bank cross-section.

A second possible installation method utilizes direct-buried conduits. For this type of installation, up to eight PVC conduits would be arranged in a trefoil configuration (two sets and a spare per circuit), with two PVC conduits bundled to each set of the power cable conduits for both fiber optic cable, GCC and a spare (Figure 6.2.1-2).



**Figure 6.2.1-2. Typical direct-buried conduit cross-section.**

In addition to the duct bank packages mentioned above, for the Oyster Creek cable route, the onshore transmission cable system may require a crossing of Oyster Creek, which may be accomplished using trenchless technologies, cable burial, or an above ground utility bridge. Utility bridges are structures constructed exclusively for utilities to cross over highways and waterways and are used as an alternative to underground or aerial crossings. The design of this structure will conform to all structural and safety standards and all pertinent State and local laws and regulations. The design envelope for the utility bridge is included in **Table 6.2.1-1**. The clearance under the utility bridge would match or exceed the clearance above water as the existing road and pedestrian bridges that cross Oyster Creek. Additionally, trenchless technologies may also be required next to the bridge on Roosevelt Boulevard as part of one of the BL England cable routes. A typical arrangement cross section of the proposed Oyster Creek HDD configuration is shown in **Figure 6.2.1-3**.

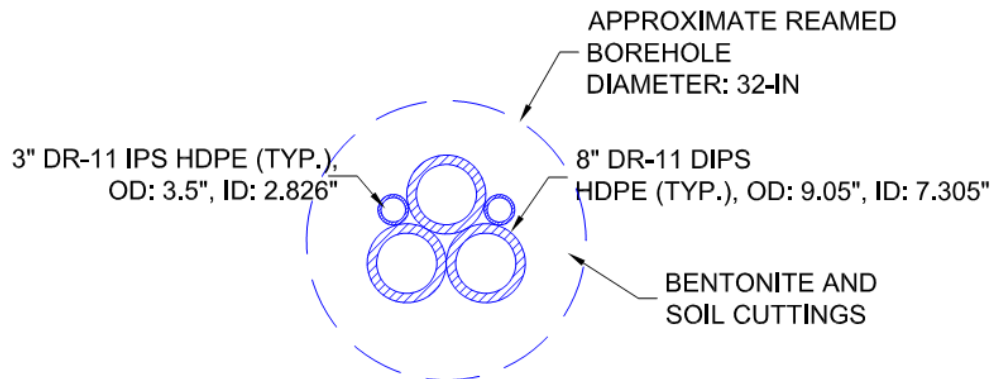

NOTES:

1. 10" DR-11 DIPS DUCT MAY BE REQUIRED, DEPENDING ON CABLE DIAMETER.
2. THERMAL GROUT FILL OF THE BOREHOLE ANNULUS MAY BE REQUIRED
3. FINAL BOREHOLE SIZE DEPENDENT ON DUCT BUNDLE DIAMETER

**Figure 6.2.1-3. Indicative HDD configuration (Oyster Creek).**

Ocean Wind will work to site the transmission cable system duct bank and splice vaults/grounding link boxes within public ROWs such that conflicts with existing utilities are minimized. Final vault spacing will be dependent on cable pulling calculations, cable manufacturer limits, and transportation logistics determined during the detailed design phase of the Project. Typical arrangement dimensions for the 275-kV splice vaults are shown in **Figure 6.2.1-4**. Following installation and jointing, access would be via manhole access lids into the chambers.

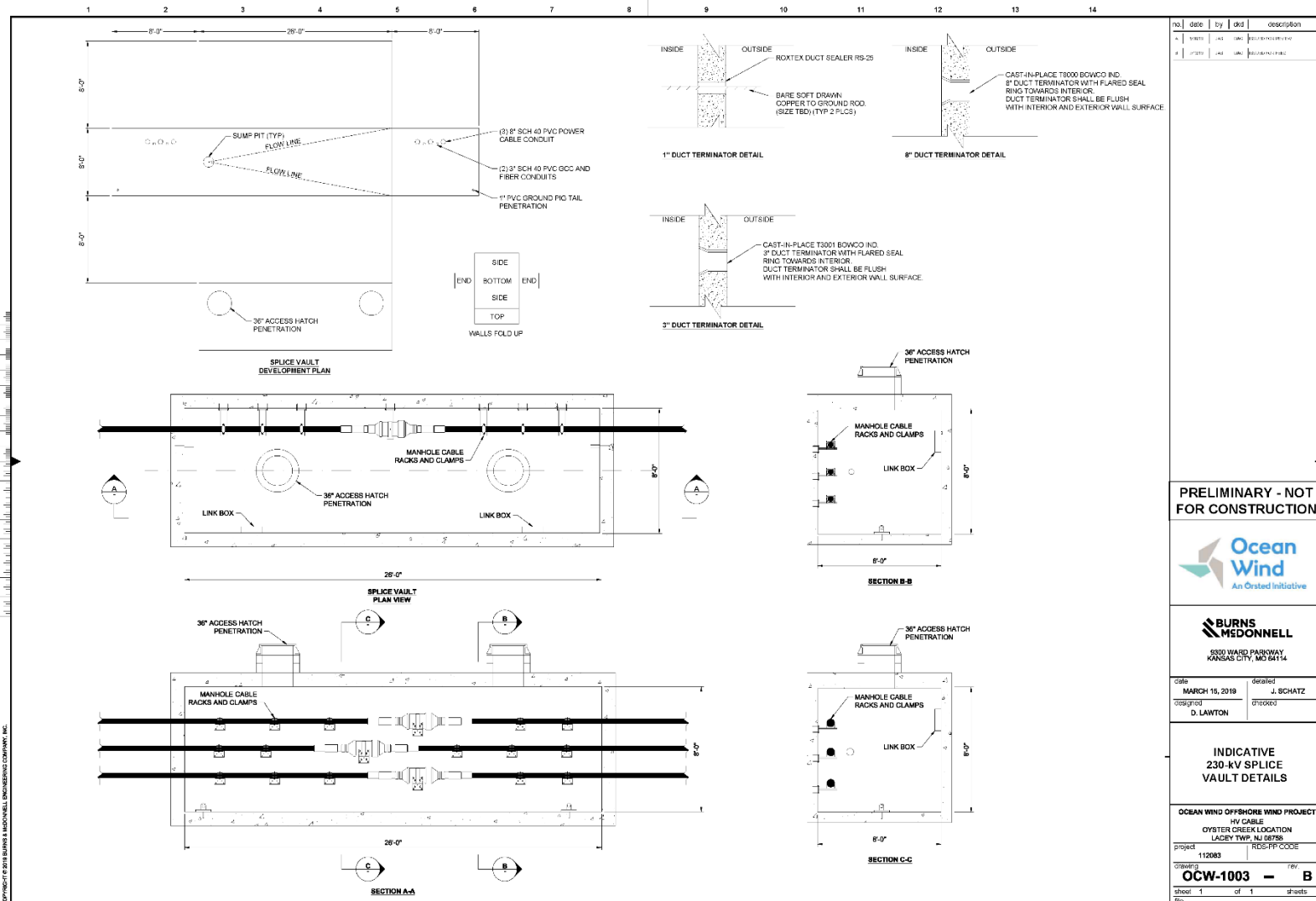

Figure 6.2.1-4. Indicative onshore transmission cable splice vault.

### 6.2.1.2 Onshore Substations

Each onshore substation would receive electricity generated at the offshore wind farm, via the onshore cable, transform the voltage to the level required for the grid connection, and provide reactive compensation. The onshore substations would include the equipment required for these purposes, as well as auxiliary equipment and facilities for operating, maintaining, and controlling the substation. Indicative substation drawings are included in Appendix U.

The engineering of the onshore substation will be based on either gas-insulated switchgear or air-insulated switchgear. Appendix U provides indicative plans for both an air-insulated switchgear substation and a gas-insulated switchgear substation. Either could be used at each of the substations. Each onshore substation will be equipped with cable terminals to accept up to five offshore export cables from the offshore platform, and up to five cables to the interconnection point with the PJM grid. A control center will be equipped with protective relaying and control systems that will provide onsite and remote control of equipment.

The major types of equipment in the onshore substation will be equipment typical to high voltage switchyards, such as switchgear (air-insulated switchgear or gas-insulated switchgear), reactors, transformers, filters, STATCOMs, and synchronous condensers. There will be multiple items of each type of equipment. Equipment selection will be identified prior to issuing invitations to tender.

The SCADA module typically consists of five main elements:

- Substation control system;
- Wind farm control system and WTG SCADA system (delivered under the WTG contract);
- Metering system;
- Information technology network system (“backbone” network); and
- Radio communication and information systems.

Each onshore substation would require a permanent site, including area for the substation equipment and buildings, energy storage and stormwater management and landscaping. During construction, additional land would be required for temporary workspace at each substation. Land requirements for each substation are provided in **Table 6.2.1-2**. The substations would include a main building and secondary buildings may be used to house reactive compensation, transformers, filters, a control room and a site office. The external electrical equipment may include switchgear, busbars, transformers, HV reactors, SVC/statcom/synchronous condensers, harmonic filters, and other auxiliary equipment. Lightning protection may consist of lightning masts each with a height up to 98 ft. Maximum height of power mast infrastructure will be 115 ft. **Table 6.2.1-2** provides the onshore substation design parameters.

**Table 6.2.1-2. Onshore substation parameters.**

Parameter	Maximum Design Parameters (Oyster Creek)	Maximum Design Parameters (BL England)
Permanent site area (acres)	31.5	13
Temporary construction workspace (acres)	2	3
Main building length (ft)	1,017	656
Main building width (ft)	492	525
Main building area (acres)	11.5	7.9
Main building height (ft)	82	82
Maximum secondary building(s) length (ft)	105	154
Maximum secondary building(s) width (ft)	105	105
Secondary building(s) height (ft)	33	33



Parameter	Maximum Design Parameters (Oyster Creek)	Maximum Design Parameters (BL England)
Fire-wall height (ft)	82	82
Number of lightning masts	35	25
Lightning protection height (ft)	98	98
Power mast infrastructure height (ft)	115	115
Transformer height (ft) <sup>1</sup>	46	46
HV reactor height (ft) <sup>1</sup>	46	46
SVC/Statcom height (ft) <sup>1</sup>	39	39
Harmonic filter height (ft) <sup>1</sup>	49	49
Bus duct height (ft) <sup>1</sup>	49	49
Other auxiliary equipment height (ft) <sup>1</sup>	33	35

<sup>1</sup> Where located in the open.

### 6.2.1.3 Onshore Grid Connection

Additional underground cables or, at Oyster Creek, overhead transmission lines, would be required to connect each onshore substation to the existing grid. Multiple circuits may be installed to each grid connection point.

For the underground option at each location, the design will be similar to the onshore export cable, but must be at the appropriate voltage to connect to the existing grid. The length and number of circuits for the grid connection will be optimized to reduce the number of splice vaults/grounding link boxes, and electrical losses. For the underground option, Ocean Wind would install a riser at the existing substation for grid connections for the proposed onshore substation location.

For the Oyster Creek interconnection, overhead transmission may be used from the onshore substation to an interconnection point at the Oyster Creek Generating Station (**Table 6.2.1-3, Figure 6.2.1-5**). The structure types anticipated are monopoles that are typical of overhead transmission lines in the area (**Figure 6.2.1-7**).

For the BL England interconnection, underground transmission cable will be used from the onshore substation to an interconnection point at Beesley's Power Substation (**Table 6.2.1-3, Figure 6.2.1-6**). An indicative plan is included in Appendix U.

**Table 6.2.1-3. Underground and overhead transmission line parameters.**

Underground Options	Parameter
Maximum trench depth (ft)	10.25
Average trench width (ft)	4.25
Maximum temporary work space, offset from centerline on each side (ft)	30
Oyster Creek	
Maximum length of onshore interconnection cable (miles)	0.5
Number of splice vaults/grounding link boxes associated with interconnection cable	2
Number of poles	1
Maximum pole height (ft)	117

Underground Options	Parameter
<b>BL England</b>	
Maximum length of onshore interconnection cable (miles)	0.5
Number of splice vaults/grounding link boxes associated with interconnection cable	2
Number of poles	1
Maximum pole height (ft)	117
Overhead Option	Parameter
<b>Oyster Creek</b>	
Maximum length of onshore interconnection cable route (miles)	0.5
Number of poles	6
Maximum pole height (ft)	115

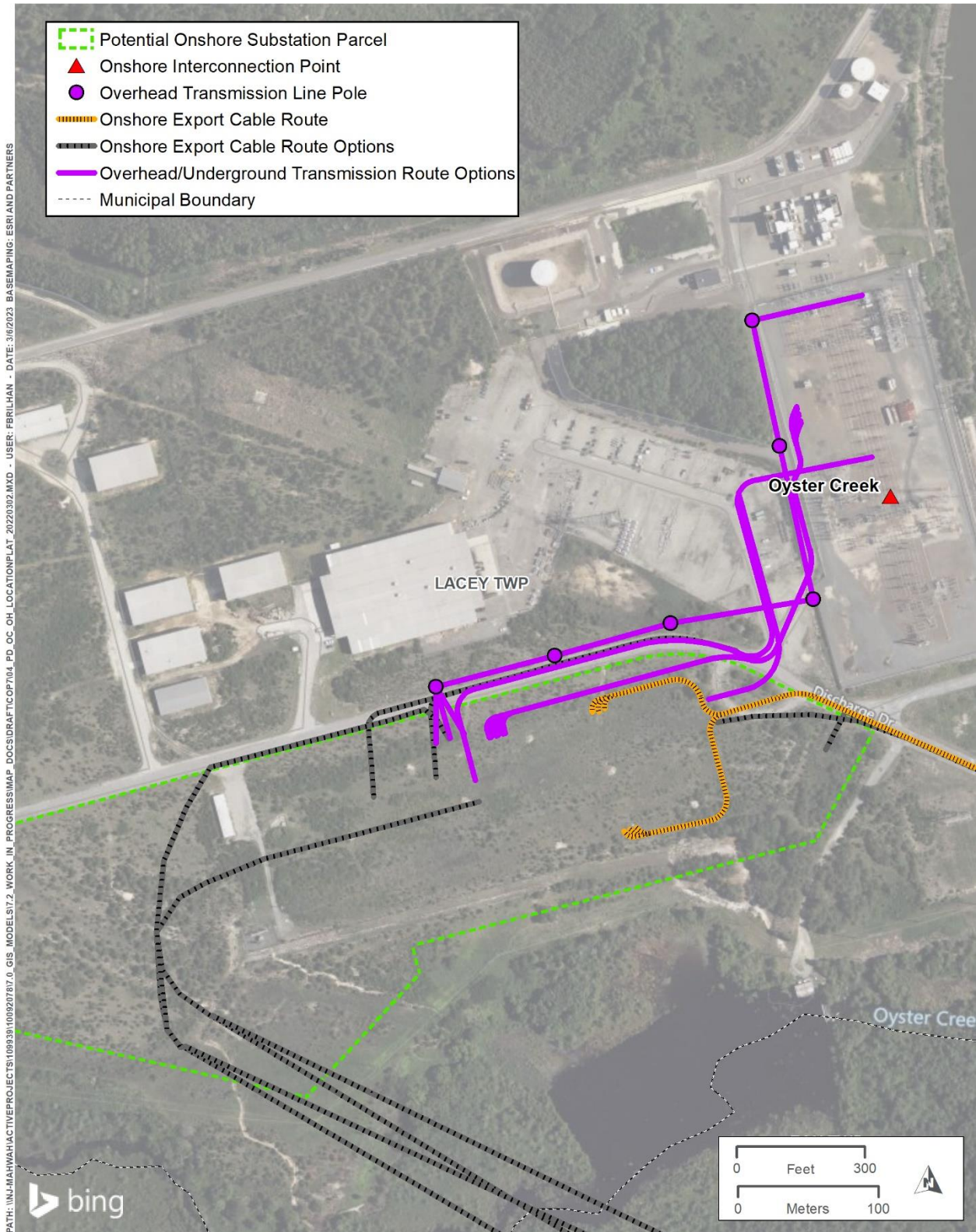
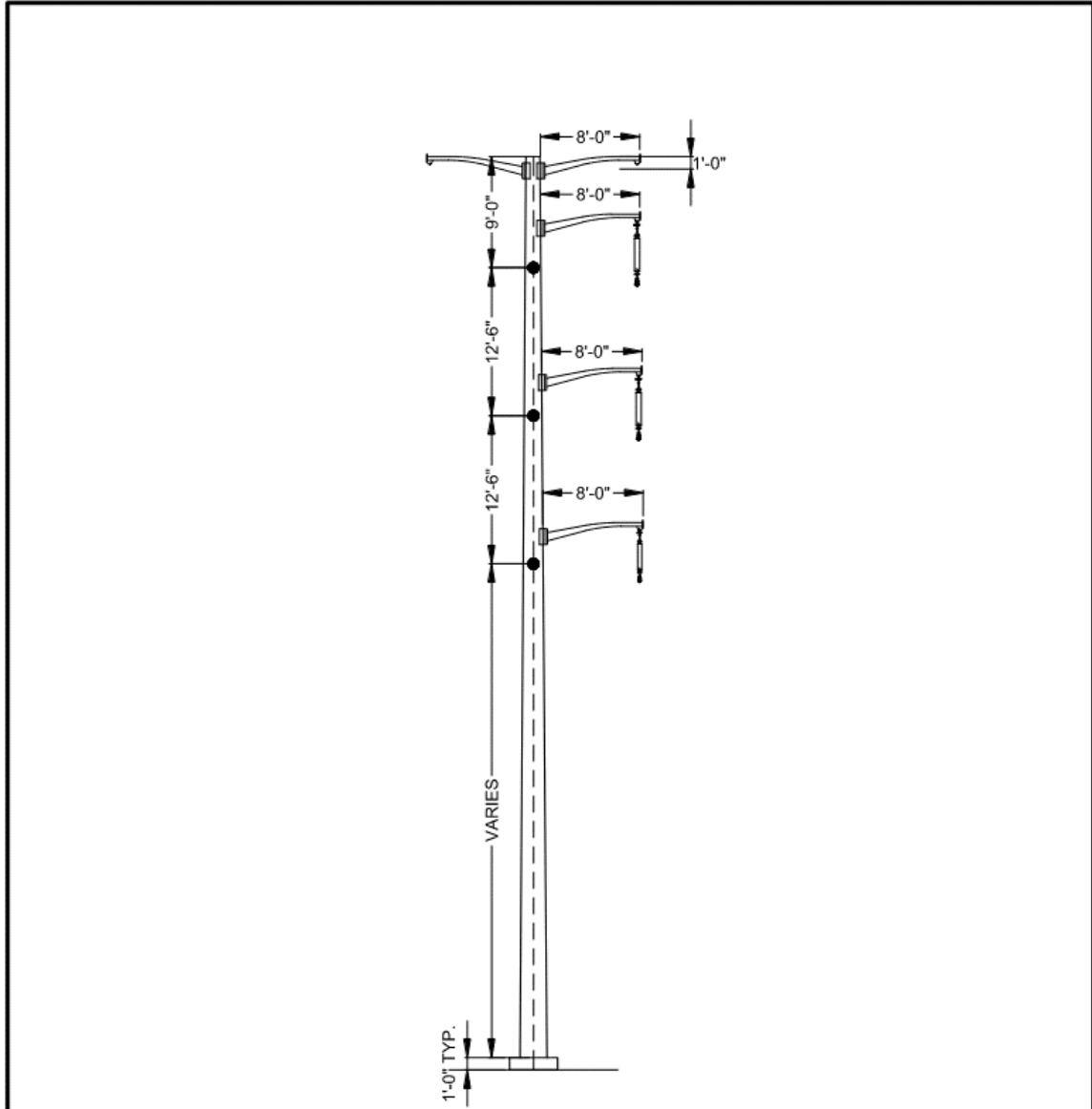

Figure 6.2.1-5. Indicative overhead transmission line/underground cable route options – Oyster Creek.



Figure 6.2.1-6. Indicative underground transmission cable route – BL England.



						PREPARED BY				
										
						138kV S/C STEEL MONOPOLE				
						VERTICAL DEADEND 0-90°				
						DES.	DR.	CK.	DATE	SCALE NONE
A	3/9/20	AKZ	INITIAL ISSUE FOR FEED REVIEW	CM	BM	APPROVED		APPROVED		INDEX
NO.	DATE	BY	DESCRIPTION OF REVISION	CK.	APP.	APPROVED		APPROVED		NO.
										SHEET NUMBER 1 OF 1

Figure 6.2.1-7. Indicative onshore transmission structure for Oyster Creek.

## 6.2.2 Construction

### 6.2.2.1 Cable Landfall

Cable landfall is where the submarine offshore cable transitions to an onshore cable. Offshore cables would be connected to onshore cables at underground TJBs located onshore. TJBs provide a clean dry environment for joining the offshore and onshore cable and provide protection to the cable joint during operation. One TJB is required for each three-core submarine cable.

Offshore export cables would be installed up to the TJB using open cut (i.e., trenching) or trenchless methods (bore or HDD) (**Figures 6.2.2-1** and **6.2.2-2**). The final method to be used shall be determined during the design and engineering phase and shall be based on an assessment of topography, bathymetry, accessibility, tidal conditions, geotechnical situation, environmental constraints and other parameters. Landfall for BL England includes beaches that are included in the USACE beach nourishment program. Based on USACE guidance, the cable must be buried at depths not attainable by open cut or trenching (-30 feet or more) and therefore HDD is the preferred option. At Oyster Creek, HDD has been selected as the approach for the east side of IBSP, and open cut has been selected for the west side of IBSP and the Holtec landfall. In other locations, the preferred methodology will be chosen to suit the conditions prevalent to ensure the optimal methodology is applied to achieve the installation with least impact. The method will be formalized in the FDR/FIR, will be reviewed by the CVA, and will be submitted to BOEM prior to construction.

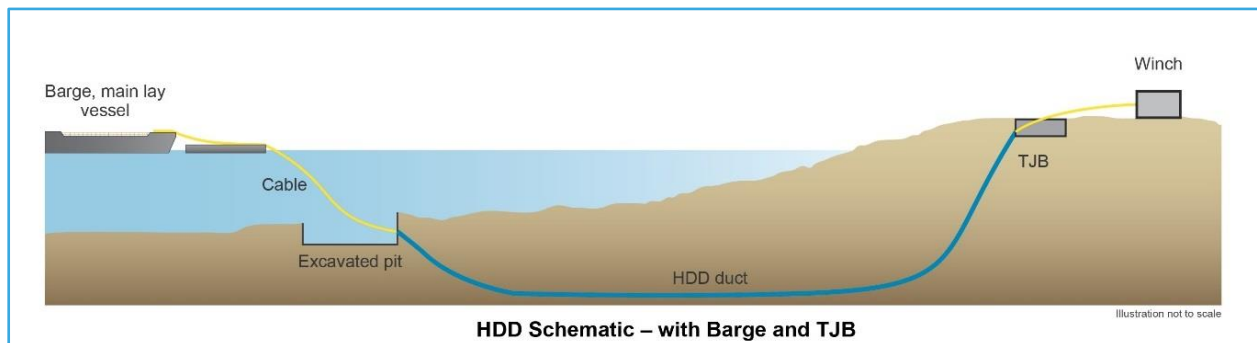

Figure 6.2.2-1. Typical transitional HDD cross-section.



**Figure 6.2.2-2. Example HDD rig in operation at entry point.**

The maximum cable landfall design parameters are provided in **Table 6.2.2-1**, These values will be finalized during the design phase as available land and engineering constraints are better defined.

**Table 6.2.2-1. Landfall parameters.**

Parameter	Maximum Design Parameters
Landfall type	Open cut or Trenchless technology
HDD noise (decibels)*	120
Number of personnel	60
Daily vehicle movements (non-HGV)	10
Daily vehicle movements (HGV)	5
Inadvertent return contingency vehicles	4
HDD exit pit depth (ft)	15
HDD exit pit (acres)	0.4 (164 ft x 98 ft)
HDD onshore workspace (acres)	15
TJB depth (ft)	20
TJB area (acres)	0.06 (33 ft x 82 ft)
TJB workspace (acres)	0.4 (131 ft x 131 ft)
<b>Oyster Creek</b>	
Number of TJBs	8

Parameter	Maximum Design Parameters
Landfall width (ft)	262
<b>BL England</b>	
Number of TJBs	3
Landfall width (ft)	131

\* Depends on rig spread to be used, phase of drilling, ground conditions, ancillary equipment, etc.

Note - Ares of workspace and disturbance are inclusive of open cut trench.

### 6.2.2.1.1 Trenchless Technology

#### **HDD**

For landfall areas, where HDD is selected, the HDD equipment will be setup near the landfall, and the bore paths will extend from land to sea, terminating at the location where the submarine cables will enter the bore(s). Exit pit locations for the HDDs will be based on the water depths allowed by the cable laying vessel or barge, and the HDD bore path geometries. An indicative layout for an HDD site is shown in **Figure 6.2.2-3**.

The HDDs will be offset from one another such to allow for landing constraints, for example, within the roadway, while maintaining suitable lateral offset between the bores. If a third circuit and HDD are deemed necessary, the HDD entry locations will be staggered so that a minimum vertical and horizontal separation are maintained between each of the bore paths. These separation requirements will be determined subsequent to the geotechnical investigation.

The HDD process involves drilling a small diameter bore along the designed drill path and subsequently enlarging the bore through a process referred to as 'reaming'. Drilling fluid containing a bentonite and water mix, is pumped at high pressure down the drill string to create the bore and ensure it remains stable. Tooling and drilling fluid is adapted and changed to compliment the ground conditions encountered to ensure the process is optimized in-situ. Once the reamed bore has been verified, a conduit is pulled into the bore, normally from offshore to onshore, using the HDD rig. The conduit string will be fused together from short sections of conduit at a suitable onshore staging location or an existing waterfront facility and maneuvered into the water and towed to the offshore HDD exit in a complete string by vessel, aligned with the bore and pulled in.

The HDD process would be supported by a marine spread, encompassing a work platform offshore and support vessels. The marine spread will assist the HDD process and ensure the connection with drilling assembly and conduit can be made. It is expected that in advance of the reaming process, the marine spread would be positioned at the HDD exit and a seabed excavation would be carried out to enable subsequent lay down and burial of the conduit installed. Typically, the HDD exit pit may be excavated deeper or casing be installed to allow for control and removal of excess drilling fluid. Where HDD is used, an HDD Inadvertent Return Plan will be developed, specifying the exact means of containment, and used during construction. Any temporary containment shall be removed upon completion of the installation.

Upon completion of the HDD and subsequent cable installation, whereby the export cable is pulled through the installed HDD conduit, a thermal grout may be pumped into the conduit to fill the annulus around the cable, where this is calculated to complement the cable ratings (the potential benefits of using a thermal grout will be evaluated during the detailed design process). After the drills have been completed and the casings installed, the submarine cables can then be pulled through the bores to the TJBs. The preliminary landfall HDD cross section is shown in **Figure 6.2.2-4**.



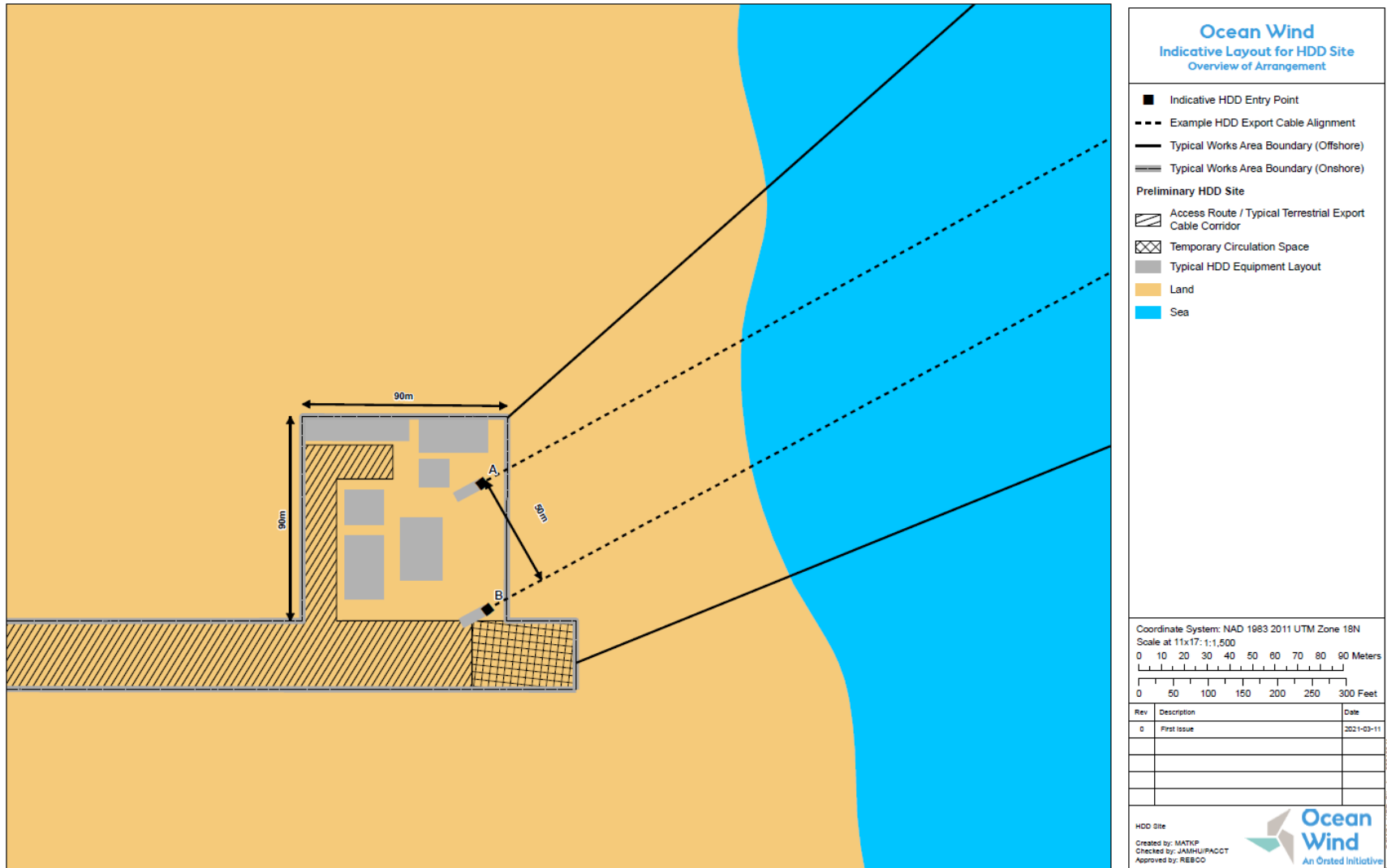
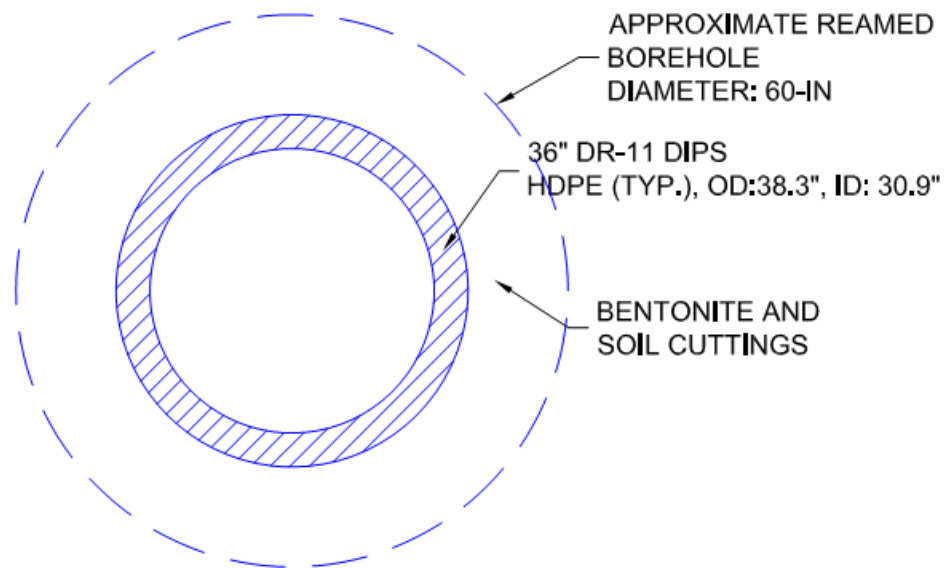

Figure 6.2.2-3. Indicative layout for HDD site.



- NOTES:
1. THERMAL GROUT FILL OF THE BOREHOLE ANNULUS MAY BE REQUIRED
  2. FINAL BOREHOLE SIZE DEPENDENT ON DUCT DIAMETER

**Figure 6.2.2-4. Indicative landfall HDD cross section.**

A temporary work area will be established in proximity to the selected landfall site. Each offshore cable will be pulled through a dedicated (and sleeved) HDD borehole and routed to a circuit-specific TJB within the temporary work area. The HDD rig will be set up at the selected landfall site with the drill directed seawards. The maximum length of the HDD bore will be dictated by the cable's torsional limits and local ground conditions. However, other factors will determine the exact length of the HDD bore, including width of the dune/beach area, designated areas, bathymetry, geologic conditions, etc. Typically, the HDD bores will "punch-out" near the 10 m contour, sufficient to accommodate the cable installation vessel (see **Figure 6.2.2-1**).

Prior to the cable installation vessel arriving at the exit site in the water, the HDD duct will be exposed, and any spoil will be deposited either on a barge or placed into a temporary cofferdam. It is anticipated that the excavation previously detailed will be backfilled upon completion or re-excavated to enable exposure of the conduit. This shall depend on the timeframe between the two operations.

The mechanism to provide a closed system and containment of drilling fluids for the HDD operation during the reaming phase shall need to be engineered accordingly, including development of an Inadvertent Return Plan, and may comprise a large diameter steel casing pipe installed into the seabed or possibly a sheet piled cofferdam or similar. In the event that the excavated pit is required, rock bags may be temporarily stored inside the pit to prevent natural backfill and keep the excavation free of debris and from silting back in. The cofferdam, if required, would be installed as a sheet piled structure into the sea floor.

The HDD duct will be lifted above the waterline by either an anchored barge, a jack-up vessel or tracked excavator, depending on the water depth and expected water conditions. Once the end-seal is removed, a winch wire will be threaded through the HDD bore and tensioned to pull the cable (via the pulling-head) from offshore through the HDD bore to the TJB.

### **Other Trenchless Technology (Direct Pipe and Auger Bore)**

Direct pipe is a curved or directional 'microtunnel' that utilizes combines elements of traditional micro tunneling and HDD. Direct pipe allows for a fully supported tunnel with a curved drill path.

Auger boring is the process of forming a horizontal bore by jacking a casing through the earth from a main shaft to a reception shaft. Spoil is removed from inside the encasement by means of a rotating auger which carry the spoil back to through the casing pipe to the main shaft for removal. An auger boring machine bores through ground with a cutting head attached to the 'lead' auger to install casing pipe.

### **Transition Joint Bays (TJB)**

The current design will utilize a TJB for each of the proposed circuits. A typical arrangement, plan and elevation view, of the proposed TJB is shown in **Figure 6.2.2-5**. The TJBs will be buried below grade. From the surface, the only visible components of the cable system will be the manhole covers.

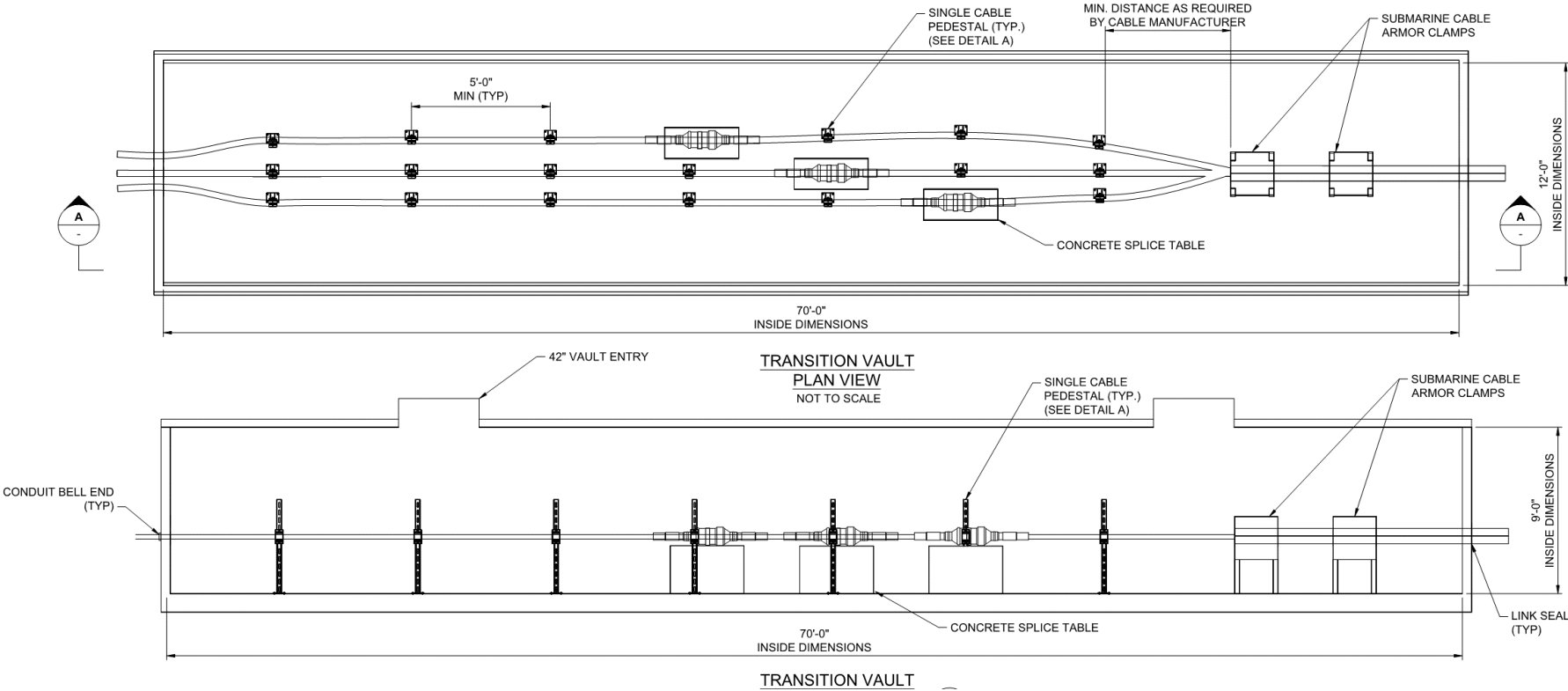

Figure 6.2.2-5. Indicative 275-kV TJB design.

#### 6.2.2.1.2 Open Cut

Open cut installation could be considered in addition to trenchless installation in areas not under the USACE beach nourishment program. For the open cut method, there are a number of options available, e.g., post cable installation burial, pre-trenching or the pre-installation of a cable duct prior to the arrival of the cable installation vessel. For the excavation work, a variety of equipment can be used depending on the water depth and local circumstances. The trench will be excavated with either land-based excavators, swamp excavators or excavators positioned on an ultra-shallow barge. The same equipment can be used to backfill the trench upon completion of the cable installation or installation of the cable conduit.

Open cut installation can be undertaken if the cable can be pulled directly from the installation vessel to the TJB without compromising any permitting constraints or topographical restrictions (**Figure 6.2.2-6**). Once the cable is pulled to, and secured at the TJB, the burial tool is pulled as close to shore as possible and subsea burial of the cable can commence. Where there is a gap between the position where the burial tool can be pulled to and the shoreline, post cable pull burial will be required. If this position is within an intertidal zone, an excavator can dig a trench into which the cable falls. Then the excavator can backfill the trench. If the position where the burial tool can be pulled to lies within the water column, sheet piling may be required to support the trench. This can be installed prior to the cable pull. After the cable pull, the trench will be backfilled and the piles removed. Where the cable pull is in excess of approximately 3,000 feet, interim tensioners will be required to reduce the cable pull tension. The tensioners are secured to the seabed by anchors or spud poles, or can be placed on a small jack up barge.

Under certain circumstances, open cut installation can be a method that is more efficient, and sometimes can have less effects, for installing cable at the landfall than trenchless technology. The method is especially suited in case of high organic material in the ground at the landing site as organic material is known to lower the power capacity of the cables causing system inefficiencies. An indicative layout for an open cut landfall is shown in **Figure 6.2.2-7**

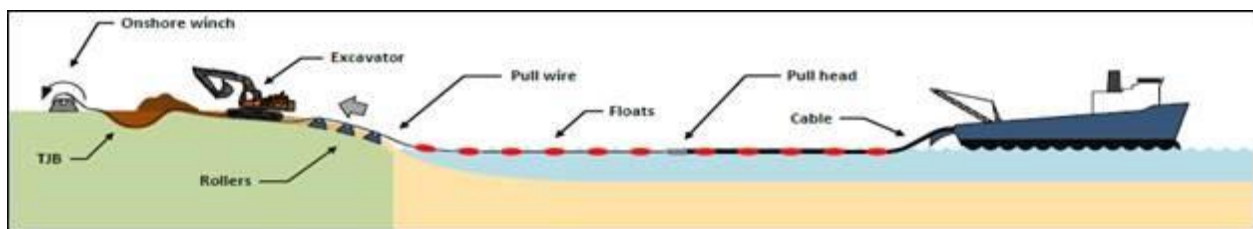

**Figure 6.2.2-6. Typical open cut landfall.**

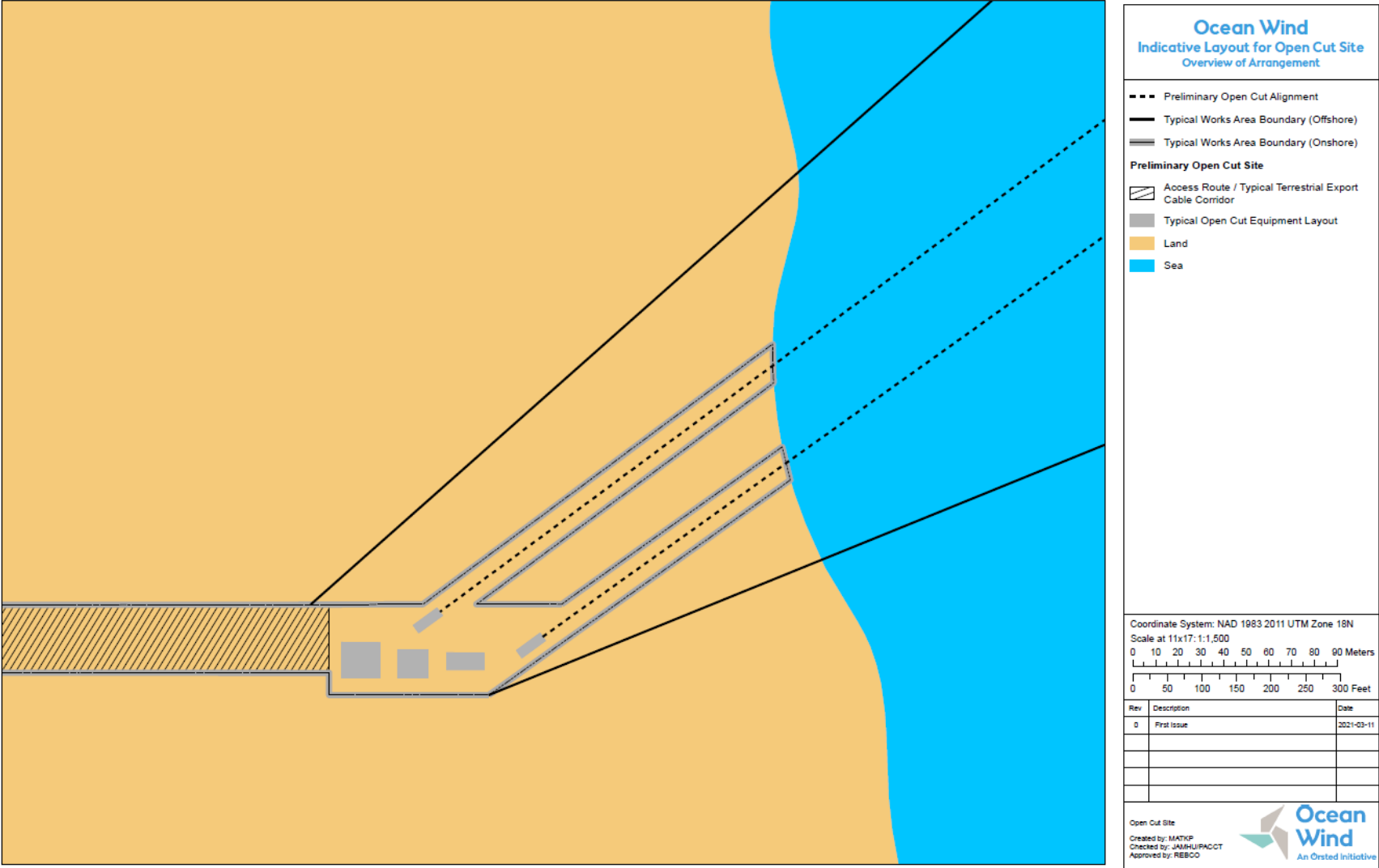

Figure 6.2.2-7. Indicative layout for open cut site.

#### 6.2.2.2 Onshore Substation

Construction of each onshore substation is expected to take up to a maximum of 36 months. Ocean Wind will be responsible for the detailed design, procurement, construction, and commissioning of the onshore substation. Ocean Wind's contractor will decide how and to what extent equipment manufacturers will be responsible for transportation, rigging, and placing the equipment- on the concrete foundations.

The rigging company is expected to be a subcontractor to the equipment manufacturer and is further expected to be responsible for all logistical services (e.g., engineered rigging and hauling plans, routing, permitting, clearance checking, escort, police escort, load analysis of transport and dimensional restrictions). When required by Ocean Wind's contractor, the rigging company may also be responsible for the temporary local warehouse storage of equipment and components. Upon installation of the equipment on the foundations, the rigging company will be responsible for checking the alignment, anchoring, and proper temporary protection from weather.

Upon placing the equipment, the manufacturers will be required to complete the attachment of all components associated with each piece of equipment. When required as part of final deployment, the equipment will be filled with an insulating fluid and/or insulating gas.

Construction would include installation of fencing around the construction workspace and a security gate. Erosion and sediment controls would be installed prior to any ground disturbing activities. Once erosion and sediment controls are in place, the site will be prepared for construction. Site preparation may include clearing and grading, installation of a gravel layer, and installation of an access road. Excavation for foundations would be prepared and foundations would be installed. Equipment would be delivered and installed on the pre-installed foundations. Buswork and ductwork for electrical connections would be installed. Cables and control equipment would be installed, and electrical connections would be completed. The station would be tested and commissioned.

#### 6.2.2.3 Onshore Export Cable Installation

Installation of onshore cable is expected to take up to 30 months with work progressing along multiple construction spreads. Up to five construction spreads are anticipated, each 2.5 to 3 miles long. Work at any location is expected to take three months to complete, and the trench in any given location is not expected to be open for more than one week.

The construction of the duct bank includes the following steps:

1. Carry out desktop assessment of existing services along the cable routes;
2. Carry out site investigation boreholes to confirm ground conditions and thermal properties of the soil;
3. Carry out test pitting to confirm presence, or lack of, services in targeted areas;
4. Survey and mark splice vault locations; survey and mark duct bank location;
5. Set up erosion and siltation controls, including silt sacks or similar protection for existing storm drains;
6. Set up traffic management measures, in coordination with local police and public works officials;
7. Open roads and install duct bank;
8. The trench will be backfilled and repaved/reinstated in accordance and agreement with the permitting and statutory requirements of the highway/ roadway or respective landowner; and
9. Clean up work area, remove erosion controls.

The duct bank installation will be performed using conventional construction equipment (e.g., hydraulic excavator, loader, dump trucks, and flatbed trucks) to deliver PVC pipe, crew vehicles, cement delivery trucks, and paving equipment).

The design of the proposed trench arrangement for the duct bank would incorporate the following considerations:

- The minimum overall width required for both the cable trench and the associated construction activities, such as excavations, trench support, vehicle movements and general safety, taking into consideration the permissible working area and in line with the United States Department of Transportation to specify the standards by which traffic signs, road surface markings, and signals are designed and installed to avoid, and minimize, the impacts on residents, businesses whilst maintaining the flow of traffic within the community to minimize any disruption.
- The appropriate size of ducts and arrangement for both ease of installation and thermal effects influencing the cable design and sizing.
- The minimum depth of cover to the top of the cables, in line with industry practices in the U.S. or New Jersey area.
- Any protective covers necessary in line with U.S. or New Jersey industry practices.
- Any preexisting utilities that are predetermined.
- The use of high-quality concrete or backfill materials to reduce the spacing between cables to minimize the overall trench width and depth and to enhance the thermal resistivity properties of the material to best influence the cable design.
- The use of any advanced construction or duct installation techniques to minimize construction activities and decrease the overall construction time. For example, for installations within the roadway it would be difficult to have a stepped or battered trench configuration due to the space restrictions and ground conditions – shoring or trench boxes would potentially be used for this type of installation. It may be possible to have a battered or sloped trench, but this would be determined by a number of factors (e.g., ground stability, water table levels and space constraints).
- The identification of preferred joint bay positions along the route, taking into consideration the maximum cable pulling length between joint bays based on the maximum installation on limitations of the cable, the location and size of any joint bays will be designed and sited to cause minimal disruption to local houses, local access, road junctions, traffic arrangements, and disruption to local residents and road users.
- Traffic management and lane closure arrangements to minimize disruption to local residents and road users.
- Construction techniques such as trenchless technology are to be considered at particular areas of engineering difficulty or areas sensitive to local residents, road users or other constraints.
- Identification of location for installation of the cables, such as roadside shoulder.

The splice vaults/grounding link boxes are typically two-piece (top and bottom) pre-formed concrete “boxes” with holes at both ends to connect with the PVC piping to the cables to be spliced. Once the duct bank is in place, the cables (one cable per duct) can be pulled using a winch wire driven by a winch.

Temporary construction staging areas may also be required on or near onshore cable route for laydown and storage of materials, employees, as well as space for small temporary offices, welfare facilities (rest rooms, changing rooms, personal storage, and rest areas), security, and parking. The construction staging areas will be removed, and sites restored to their original condition when construction has been completed. The size of these staging areas is not currently anticipated to be greater than 270 ft by 300 ft and locations will be determined during the detailed design and positioned based on available land.



#### 6.2.2.4 Onshore Grid Connection

Ocean Wind is considering both underground and overhead transmission lines for grid connections at Oyster Creek, and underground transmission lines at BL England. The alignment of the onshore interconnect cable system duct bank will be spaced at a minimum of 15 feet from the onshore transmission cable system duct bank, in order to maintain thermal isolation between the two circuits.

The two installation methods described above (concrete-encased duct bank or direct-buried conduits in trefoil) will also be the options used for the onshore interconnect cable system. Currently, no splice vaults/grounding link boxes are anticipated for the onshore interconnect cable system duct bank pending final design and termination locations inside the proposed export substation and the local utility's substation.

Overhead lines may be used instead for the interconnection at Oyster Creek subject to landowner consent. If overhead lines are utilized, the construction will begin with constructing the foundations for the transmission structures, then installing the steel poles, finally installing conductors between the poles and connecting to the substations at each end. The foundations are anticipated to be concrete drilled shaft type foundations. The depth and diameter of the foundations will depend on soil geotechnical conditions and specific loading conditions on the poles. The installation will be performed using augers, cranes (for rebar and anchor bolt cages), and concrete trucks. Following foundation installation (and appropriate concrete curing time), the poles will be set on the foundations using cranes. Once all of the poles are set, three sets (phases) of conductor and one shield wire will be installed between each pole and tensioned to appropriate design tensions, and electrical "jumpers" installed on the poles between the conductors on each side. The total construction time for the overhead transmission installation is anticipated to be approximately two to three months, depending on the final design parameters and number of poles. Laydown areas for the overhead lines will be within the workspace for the new substation. No additional laydown areas will be required.

Construction of the underground interconnection cable option will be similar to that described for onshore export cables. A riser will be installed to bring the interconnection cable aboveground at the existing substation. Construction of the riser will begin with the foundation, then the steel riser will be installed, and finally conductors will be installed from underground line to the riser and connected to the substations at each end. The foundations are anticipated to be concrete drilled shaft type foundations. The depth and diameter of the foundation will depend on soil geotechnical conditions and specific loading conditions on the riser. The installation will be performed using augers, cranes (for rebar and anchor bolt cages), and concrete trucks. Following foundation installation (and appropriate concrete curing time), the riser will be set on the foundations using cranes. The total construction time for the underground interconnection line installation is anticipated to be approximately two to three months. Laydown areas for the underground interconnection lines will be within the workspace for the new substations. No additional laydown areas will be required.

### 6.2.3 Operation and Maintenance

#### 6.2.3.1 Onshore Operation and Maintenance Facilities

The operation phase of the Project will include the use of an onshore O&M facility in Atlantic City. The O&M Facility will serve as a regional operations and maintenance center for multiple Orsted intends to develop in the mid-Atlantic, including the Project.

Orsted has identified parcels, 600 & 701 North Delaware Ave., Atlantic City, which are adjacent to Clam Creek (**Figure 6.2.3-1**). The parcels served as a marine terminal for 70 years, until the 1970s. There are two existing buildings on the site. A small one-story structure in the southeast portion would remain as a police community center, and the other building would be demolished.

The O&M facility would contain up to 26,900 ft<sup>2</sup> of office space and up to 21,530 ft<sup>2</sup> of warehouse and workshop space. Approximately 500 ft of dockside harbor facilities and associated parking facilities will be added.



**Figure 6.2.3-1. Proposed location of O&M facility.**

Operational hours will be 24 hours per day, seven days per week. The number of onshore personnel has not been determined.

The City of Atlantic City intends to secure authorization for marina upgrades, namely dredging in the marina and at Absecon Inlet, for the benefit of multiple marina users, and both this in-water activity and upland improvements by Orsted (including office and warehouse) are being separately reviewed and authorized by the USACE and state and local agencies. In particular, the USACE has recently confirmed to Ocean Wind that all work at the O&M facility (both in-water and upland improvements) will be considered as part of USACE's Section 106 consultation. This work would be completed in advance of, and is not dependent upon, approval of the Project.

Thus, although the O&M Facility complements and benefits the Project, it will be reviewed in conjunction with other activities and benefits to other marina users (such as dredging of Absecon Inlet); and it is not necessary for BOEM to consider it part of the same undertaking as the Project's subsequent Section 106 consultation.

#### *6.2.3.2 Onshore Operation and Maintenance Activities for Onshore Electrical Plants*

O&M activities at onshore electrical plants will include inspections, preventive maintenance, and corrective maintenance. Inspections would occur as often as weekly. Routine preventive maintenance would occur annually for main servicing, but individual aspects may occur each quarter. Corrective maintenance would occur as required. Ocean Wind will monitor the onshore substations both remotely and locally on a continuous basis. The equipment in the onshore substations will be configured with a condition monitoring system that will

sound an alarm upon detecting equipment faults, unintended shutdowns, or other issues. Ocean Wind will put in place an established and documented program for the maintenance of all equipment critical to reliable operation. Maintenance programs will conform to the equipment manufacturer's warranty requirements.

In addition, a reliability-centered maintenance program will be implemented. Preventive maintenance will be performed on the onshore substations and line equipment, and planned outages will be conducted in accordance with applicable Reliability First Region standards, and protective system maintenance will be performed in accordance with the applicable Reliability First Region standard. Equipment will be maintained in accordance with the interconnection agreement; maintenance will be completed by qualified personnel in accordance with applicable industry standards and good utility practice to provide maximum operating performance and reliability.

Typical maintenance activities for overhead grid connection, if used at Oyster Creek, will include replacing transmission poles and stringing new cable. This typically will be planned in advance and due to the short distance these would be used, is expected to happen once during the lifetime of the Project. To support O&M of the onshore overhead grid connection, up to a 100-ft-wide operational ROW centered on the cables will be requested.

#### 6.2.4 Non-routine Activities

Non-routine activities for onshore facilities would be unscheduled maintenance and repairs similar to those described for offshore facilities in Section 6.1.4.

### 6.3 Decommissioning Plan

At the end of the operational lifetime of the Project, Ocean Wind will decommission the Project in accordance with 30 CFR § 585.902 and 30 CFR §§ 585.905 through 585.912. The process will start with the submission of a decommissioning application in accordance with 30 CFR § 585.905. It is anticipated that all structures above the seabed level or aboveground will be completely removed. The decommissioning sequence will generally be the reverse of the construction sequence, will involve similar types and numbers of vessels, and will use similar equipment.

Although decommissioning may not require the same level of precision and care as the initial installation, it will nonetheless be undertaken in the same controlled manner and in accordance with an approved risk management plan to ensure the highest levels of safety.

#### 6.3.1 Offshore Decommissioning

The dismantling and removal of the turbine components (e.g., blades, nacelle, and tower) will largely be a "reverse installation" process subject to the same constraints as the original construction phase. Using today's technology, dismantling the turbine components requires a jack-up vessel to ensure adequate control of the demolition process and to manage the high lifts and high crane hook loads.

It is anticipated that the monopile foundations will be cut below the seabed level in accordance with standard practices at the time of demolition. The exact depth will depend on seabed conditions (e.g., dynamics and site characteristics) and developing industry best practices. The cutting process is likely to be via mechanical cutting, water-jet cutting, or other common industry practices.

If deployed, the scour protection placed around the base of each monopile will be left in situ as the default option in order to preserve the marine life that may have established itself on this substrate during the period of operation. If it is necessary to remove the scour protection, then the removal will proceed according to the best practices applicable at the time of decommissioning.

The offshore substation will be decommissioned by dismantling and removing its topside and foundation (substructure). As with the turbine components, this operation will be a reverse installation process subject to the same constraints as the original construction phase.

Offshore cables will either be left in situ or removed, or a combination of both, depending on the regulatory requirements at the time of decommissioning. It is anticipated that the array cables will be removed using controlled flow excavation or a grapnel to lift them from the seabed. Alternatively, depending on available technology, a ROV may be used to cut the cable so that it can be recovered to the vessel. The export cables will be left in situ or wholly/partially removed. Any cable ends will be weighed down and buried if the cables are to be left in situ to ensure that the ends are not exposed or have the potential to become exposed post-decommissioning. Cables may be left in situ in certain locations, such as pipeline crossings, to avoid unnecessary risk to the integrity of the third-party cable or pipeline.

### 6.3.2 Onshore Decommissioning

Onshore cables generally will be abandoned in place. Some components of the onshore electrical infrastructure may still have substantial life expectancies at the time of decommissioning. Hence, the potential reallocation of some or all of these assets may be investigated with PJM, the onshore grid operators. The future disposition of this infrastructure will depend in part on these discussions.

Any cable ends will be buried if the cables are to be abandoned in situ to ensure that the ends are not exposed or have the potential to become exposed post-decommissioning. If buried cables are removed in most locations, they may be left in situ in certain specific locations such as road or railroad crossings to avoid unnecessary risk to the integrity of the surrounding infrastructure. Onshore cables installed overhead may either be used for other projects or be removed depending on the need at that time.

Offshore wind turbines have a large amount of material that must be removed after the structures are decommissioned. Disposal will be according to decommissioning industry best practices and the applicable regulations at the time of decommissioning. The appropriate waste hierarchy will also be followed: reuse is considered first and maximized when possible, followed by recycling, incineration with energy recovery, and lastly, disposal.

## 7. Health and Safety

### 7.1 Introduction

Appendix B provides the project Safety Management System (SMS) developed for the Ocean Wind Offshore Wind Farm. This SMS describes leadership commitments and the Health and Safety (H&S) responsibilities of the Project employees working on-site, including the Project H&S policy, orientation and training, safe work practices, standards and procedures, transportation and logistics, monitoring and implementation, and other Project safety requirements. The Project SMS is applicable to all activities performed in relation to Project offices, Project travel, and other work locations, including vessels, ports, and construction sites.

The goal of the Project SMS is to identify and mitigate hazards associated with the activities undertaken by employees, contractors, and their subcontractors which have the potential to impact human health, safety, or the environment. The Project SMS is based on over 25 years of hands-on experience by Orsted in developing and operating offshore wind projects across Europe and Asia. The Project SMS is founded on this experience and is guided by the following commitments to promote a safe workspace:

- Provide and maintain safe working environments where risks to health, safety, and welfare are either eliminated, controlled, or reduced to As Low As Reasonably Practicable (ALARP).

- Set standards which, at a minimum, comply with the relevant statutory requirements relating to health, safety, and welfare with regard to the effect on employees, contractors, subcontractors, visitors, and the general public.
- Safeguard employees and others from foreseeable hazards connected with work activities, processes, and working systems.
- Require that adequate guidance, instruction, training, and supervision is provided when new substances, plant machinery, equipment, processes, or premises are introduced, in order to develop safe work practices.
- Train all employees to be aware of their own responsibilities with respect to relevant H&S matters, and require that they help prevent accidents and implement measures to prevent work-related injury.
- Require that contractors and subcontractors be informed of the relevant training and standards required, and are monitored and encouraged to promote compliance without detracting from the contractors' legal responsibilities to comply with statutory requirements.
- Promote good H&S practices amongst employees and be concerned with preventing occupational and non-occupational disorders and diseases.
- Cooperate with the appropriate authorities and technical organizations to update policies and review standards so that they reflect best practices.
- Conduct inspection, audits, and reviews to achieve the Project's H&S objectives.

## **7.2 Major Components of the Project SMS**

The following subsections summarize the major components of the Project SMS. Appendix B should be consulted for more details.

### **7.2.1 Ocean Wind Organization**

The Project SMS includes a well-defined organizational structure to clearly designate specific roles, lines of authority, and responsibilities for the (a) program director, (b) mid-level managers (i.e., project development managers, package managers, consent project managers, technical project managers, and commercial project managers), (c) the project safety manager, (d) the safety department, and (e) employees, contractors, and subcontractors.

### **7.2.2 Communication Plan**

Contractor safety plans will be assessed and approved (or modified, as needed) before the start of any Project work to ensure that these plans align with the Project SMS and are properly communicated to all employees, contractors, and third parties. External communications, such as notice to mariners, notice to specific parties, or other public announcements will be issued, as needed.

All employees are encouraged to participate in safety campaigns, safety meetings, and other safety-related activities. These efforts include contractors establishing a strong working relationship with their subcontractors in order to align themselves with Ocean Wind's quality, health, safety, and environment strategy and programs, maintain on-going relationships, and foster review of safety programs.

Safety campaigns are implemented at the Project site to highlight specific work-related hazards and provide educational materials to all Project workers to promote safety awareness and provide risk mitigation information.

Safety alerts (i.e., a document that identifies an issue which represents a significant risk to personnel, assets, or equipment, and requires an immediate response) and safety notices (i.e., a document which communicates issues which are significant but do not represent a substantial risk to personnel, assets, or equipment, and do

not require an immediate response) may be sent out to the Project as required to communicate safety concerns and the need to undertake specific actions to mitigate the risk of a new hazard or emerging trend.

### 7.2.3 Contractor Management

Only those contractors and subcontractors with strong safety performance and health, safety, and environment (HSE) management systems are allowed to perform work on the Project. Each contractor must submit for review their safety plan, SMS, work procedures, and the results of the risk assessments of their work activities. Project management staff engages with contractors and subcontractors throughout the entire contractor relationship to communicate safety expectations, improve safety performance, and approve permits to work.

### 7.2.4 Risk Management Process

Ocean Wind has adopted a risk-based approach to manage the safety risks to its employees, contractors, and subcontractors in all phases of the Project. This approach requires identifying and evaluating all the hazards that may impact health and safety. Any risks present during the design and planning stages are mitigated to the extent possible to meet a tolerable level. This risk is further assessed and managed to a level considered to be ALARP before the work activities are executed in the field. Risk management programs have been developed to address key hazards that significantly impact worker safety during the execution of the Project. These key hazards are as follows:

- Alcohol and drugs;
- High- and low-voltage electricity;
- Vessel operation;
- Extreme weather;
- Transfer onto or off of offshore structures;
- Craning and lifting;
- Manual material handling;
- Remote monitoring, control, and shut down;
- Fall protection;
- Control of hazardous energy (lockout tagout);
- Confined space entry;
- Hazardous chemicals;
- Personal protective equipment;
- Fire prevention;
- Hot work (open flames, grinding, welding, plasma cutting, other heat-generating work);
- Diving; and
- Welfare facilities (rest rooms, changing rooms, personal storage, rest areas).

### 7.2.5 Competence, Training, and Awareness

All contractors hired for the Project are selected based on their track record to safely perform their assigned work scope. Competence is determined based on their qualifications, training, and experience. The Global Wind Organization Basic Safety Training, or an equivalent standard, is demanded as a minimum training requirement for offshore workers. This training establishes that all personnel accessing and working on an offshore project have a common understanding, awareness, and training in (a) working and rescue at height, (b) first aid, (c) manual handling, (d) fire awareness, (e) sea survival, and (f) vessel transfer.

### 7.2.6 Medical Clearance

All workers will be evaluated by a licensed medical physician to determine that they are physically and mentally fit to perform their assigned duties before they are authorized to work on the Project. All workers must also

possess a medical clearance certificate consisting of a medical examination and physical capability assessment.

#### 7.2.7 Emergency Preparedness and Response

The Project emergency response plan (ERP) identifies procedures that are appropriate and consistent with best practice. The Project ERP is tested and evaluated through drills and table-top exercises to assess its effectiveness. Drills also test performance across management levels and the success of the training programs. Ocean Wind's coordinates the communication of its ERP with all on-site contractors and relevant subcontractors. A gap analysis is performed where multiple ERPs exist in order to identify differences and inconsistencies. If necessary, a bridging document establishing an agreed-upon coordination of response activities is created and implemented.

#### 7.2.8 Incident Reporting and Investigation

All incidents, near misses, and observations of unsafe conditions or behaviors at the Project site will be reported, no matter how insignificant. An incident investigation will be conducted following a serious incident in order to identify the root cause and causal factors, and establish corrective action to prevent similar incidents from occurring in the future. The applicable Project or site manager will be assigned responsibility to implement the corrective action.

#### 7.2.9 SMS Evaluation and Monitoring

Ocean Wind uses both inspections and audits to check the completion of objectives and to measure the effectiveness of assigned actions. Project and site managers plan safety inspections to (a) maintain a safe work environment, (b) verify that workers follow approved procedures, and (c) ensure that the facility and equipment meet relevant safety standards. Internal and external audits are performed to evaluate legal compliance with and the effectiveness of the Project SMS.

#### 7.2.10 SMS Review

Orsted conducts regular management review meetings to evaluate (a) its management system, (b) the overall performance of its activities (including the adequacy of the management system), and (c) the strategy to manage the HSE impacts of its activities.

Similarly, the Ocean Wind steering committee conducts a regular review during the development and construction phases of the Project to evaluate the HSE performance of the Project and the Project's safety performance and ability to manage HSE risks.

### **7.3 Cybersecurity**

Information technology (IT) Cybersecurity risks will be regularly evaluated and incorporated within the designs for the SCADA Control System. Various IT security measures are established to protect against unauthorized intrusion. Cybersecurity risks are managed by SCADA Communication and Orsted IT. Cybersecurity risks have been evaluated and incorporated within the designs for the SCADA Control System. Security measures to protect against unauthorized intrusions or access meet existing NERC Critical Infrastructure Protection requirements. Among these measures include Physical Security Perimeters, Electronic Security Perimeters, Electronic Access Points, encrypted communication, firewalls handling all external communication and a demilitarized zone between the process control network and the plant information network, network access storage, and an Information Security Management Audit program. Where vulnerabilities are identified in incidents or audits, they are investigated to establish the threat points and additional measure are implemented to prevent recurrence.

## 7.4 Obstruction Lighting and Markings

### 7.4.1 Obstruction Lighting

Ocean Wind will adhere to FAA filing requirements for the WTGs, as applicable<sup>9</sup>. All WTGs will be lighted and marked in accordance with FAA Advisory Circular 70/7460-1L (FAA 2018), and as recommended by BOEM's guidance on marking and lighting offshore wind farms (BOEM 2021), as detailed below:

- Red wavelength light emitting diode lighting should be in the infrared portion of the spectrum between 800 and 900 nanometers to ensure compatibility with night vision goggles;
- Lights should have photometric values of an FAA Type L-810, L-864, and L-885 medium intensity red obstruction light;
- Lights should flash simultaneously at 30 flashes per minute (FPM);
- Structure lights should be visible in all directions in the horizontal (i.e., visible spread from 360 degrees);
- For any turbines with a tip height of 699 ft or less, lighting should be placed at the highest point of the turbine nacelle. For any turbines with a tip height greater than 699 ft, lighting should be placed at both the highest point of the turbine nacelle and mid-mast;
- Every turbine should be outfitted with a light, but not all turbine lights need to be turned on as long as there are no unlit separations or gaps of more than 0.5 statute miles between the turbines around the perimeter of the entire facility;
- There should be no unlit separation or gaps of more than 1 statute mile within the facility (or cluster of turbines within the facility); and
- All turbines above 499 ft should remain lit during nighttime hours unless connected to an approved aircraft detection lighting system (ADLS).

Ocean Wind proposes to implement an ADLS to automatically turn the aviation obstruction lights on and off in response to the presence of aircraft in proximity of the wind farm. Such a system may reduce the amount of time that the lights are on, thereby potentially minimizing the visibility of the WTGs from shore; this system would not, however, increase the potential for impacts to aviation in the Wind Farm Area.

The offshore substations will be lit and marked in accordance with FAA and USCG requirements and BOEM proposed guidance for aviation and navigation obstruction lighting, respectively. Aviation lights placed on top of the nacelle of each WTG will flash in a synchronized fashion. Finally, in order to minimize light pollution and confusion for mariners, the aeronautical obstruction lights fitted to the tops of the WTGs will not be visible to mariners below the horizontal plane of these lights.

### 7.4.2 Markings

The WTGs will each be lit, individually marked, and maintained as private aids to navigation in accordance with the guidance provided in the *Aids to Navigation Manual* (USCG 2015) and will also comply with *International Association of Marine Aids to Navigation and Lighthouse Authorities (IALA) Recommendation O-139 on The Marking of Man-Made Offshore Structures* (IALA 2013) and, unless a deviation requested, the BOEM guidance on marking and lighting of offshore wind farms (BOEM 2021) which requires:

- All turbines should be marked conspicuously and distinctly for both day and night recognition;
- The foundation base of all turbines should be painted yellow, RAL 1023, all around from the level of Mean Higher High Water (MHHW) to 50 ft above MHHW;

---

<sup>9</sup> The Project is being proposed greater than 12 miles offshore which is outside the FAA jurisdictional limit. However, it is assumed that BOEM will adopt similar requirements.



- Ladders at the foundation base of all turbines may be painted in a color that contrasts with the recommended yellow. Painting the ladders in a distinguishable color will allow for ease of identification for operations and maintenance personnel;
- Wind energy facilities should have flashing yellow lights energized from sunset to sunrise and from sunrise to sunset in restricted visibility. Structure lights should be visible in all directions in the horizontal (i.e., visible spread from 360 degrees);
- Retro-reflective material (white, yellow or silver) may be used, visible through a 360-degree arc, and should be applied in at least 2-foot bands around structures, no less than 30 ft above MHHW;
- Each wind turbine generator in a wind energy facility should be designated, marked, and charted with a unique alphanumeric designation, which enables quick recognition and reference by mariners and agencies for search and rescue, law enforcement, and other purposes. The bottom of the alphanumeric characters should be located at least 30 ft and no more than 50 ft above MHHW. The alphanumeric characters should be as near to 9.8 ft in height as practicable, should be visible above any service platforms in a 360-degree arc from the water's surface, and should be applied with retro-reflecting paint or material to enhance visibility under low light conditions. If feasible, each generator's unique alphanumeric designation should be duplicated below any servicing platform;
- Significant Peripheral Structures (SPS) (i.e., "corners" or other significant peripheral points) should be marked with quick flashing yellow lights with an operational range of not less than 5 nm;
- Intermediate Perimeter Structures (IPS) are those located along a wind energy facility's outside boundary between SPSs. IPSs should be marked with 2.5-second flashing yellow lights with an operational range of not less than 3 nm;
- For larger wind energy facilities with multiple levels, inner boundary towers may be identified as those immediately inside the line of IPS and SPS towers. These should be marked with 6- or 10-second flashing yellow lights with a 2-nm operational range;
- Other turbines inside the wind energy facility should be marked with 15-second flashing yellow lights with a 1-nm operational range;
- Lights serving the same function (SPS, IPS, inner boundary, etc.) should be synchronized.
- In the case of 2 or more adjacent wind energy facilities, USCG may coordinate marking and lighting characteristics or synchronization across the wind energy facilities to best support safe navigation through all abutting areas; and
- All temporary foundation base, tower, and construction components should be marked only with quick flashing yellow obstruction lights visible in a 360-degree arc with a 5-nm operational range. This lighting configuration requires USCG notification, but not a PATON permit, for appropriate marine notices and broadcasts until the final structure marking is established. .

## **8. Waste Management and Chemicals**

The Emergency Response Plan, which includes an Oil Spill Response Plan, is contained in Appendix A.

### **8.1 Chemicals**

Project facilities will contain components that require lubricating oils, hydraulic oils, and coolants for operation, as well as fuels and batteries. In some design concepts, electrical plant equipment commonly associated with the offshore substation may be included on the turbine. To avoid complicating the design envelope, the chemicals associated with electrical plants on the turbine are accounted for in the electrical substation design parameters. The spill containment strategy for each offshore substation is comprised of preventive, detective, and containment measures. The offshore substations will be designed with a minimum of 110 percent of

secondary containment of all identified oils, grease, and lubricants. These measures are discussed in more detail in the Emergency Response Plan in Appendix A.

**Table 8.1-1** shows the maximum requirements for oils and fluids in a single offshore wind turbine. The spill containment strategy for each WTG is comprised of preventive, detective and containment measures. These measures include 100 percent leakage-free joints to prevent leaks at the connectors; high pressure and oil level sensors that can detect both water and oil leakage; and appropriate integrated retention reservoirs capable of containing 110 percent of the volume of potential leakages at each WTG.

**Tables 8.1-2 through 8.1-3** show the maximum anticipated requirements for a single offshore substation and onshore substation.

**Table 8.1-1. Summary of maximum potential volumes oils, fuels, and lubricants per WTG.**

WTG System/Component	Oil/Fuel Type	Oil/Fuel Volume
WTG Bearings and yaw pinions	Grease <sup>a</sup>	187 gallons
Hydraulic Pumping Unit, Hydraulic Pitch Actuators, Hydraulic Pitch Accumulators	Hydraulic Oil	40 gallons
Drive Train Gearbox (if applicable), Yaw Drives Gearbox	Gear Oil	106 gallons
Transformer	Dielectric Fluid	1,585 gallons
Emergency Generator	Diesel Fuel	1,200 gallons
Switchgear	Sulfur Hexafluoride (SF6)	243 lbs
Transformer and Converter Cooling System	Propylene Glycol	357 gallons
Converter Primary Cooling	Ethylene Glycol	48 gallons

<sup>a</sup> Approximately 26 gal to 40 gal (100 L to 150 L) per large bearing.

**Table 8.1-2. Summary of maximum volumes oils, fuels, and lubricants per offshore substation.**

Equipment	Oil/Fuel Type	Oil/Fuel Volume
Transformers and Reactors	Transformer oil	79,252 gallons
Generators	Diesel Fuel	52,834 gallons
High-Voltage & Medium-Voltage Gas-insulated Switchgear	Sulfur Hexafluoride (SF6)	4,950 lbs
Crane	Hydraulic Oil	317 gallons

**Table 8.1-3. Summary of maximum volumes oils, fuels, and lubricants per onshore substation.**

Parameter	Oil/Fuel Volume
Transformer oil substation	38,170 gallons
Fixed shunt reactor 1 oil	15,500 gallons
Fixed shunt reactor 2 oil	7,350 gallons
Variable shunt reactor oil	18,300 gallons
SF6 substation	6,603 lbs
Batteries (lead acid gel)	4,034 lbs

## 8.2 Waste Management

Anticipated solid and liquid wastes generated by the Project during the construction, operation, and decommissioning phases, and their disposal methods are outlined below and managed through the Safety Management System (Volume III Appendix B). The Safety Management System details how the Project would manage, store dispose and record wastes.

### 8.2.1 Offshore Wastes

Draft plans regarding how Ocean Wind will implement appropriate and legally compliant waste management practices are included in the Safety Management Plan in Volume III, Appendix B. Ocean Wind will meet applicable regulations and standards, as set by the International Maritime Organization’s International Convention for the Prevention of Pollution from Ships (IMO MARPOL), the USCG, and applicable State regulations, for treatment and disposal of solid and liquid wastes generated during all phases of the Project. Solid and liquid waste volumes for the Project will be updated for the Facility Design Report and Fabrication and Installation Report.

Wastes generated offshore are containerized, segregated and categorized. Wastes would then be transported via vessel to an onshore storage location until coordination can occur for pickup and disposal by a licensed waste management company. Wastes generated during offshore work, including those from vessel activity during the construction, operations, and decommissioning phases, and disposal are listed in **Table 8.2-1** along with the potential treatment methods.

**Table 8.2-1. Anticipated solid and liquid wastes generated during offshore work.**

Source <sup>a</sup>	Method of Disposal
Oily bilge water	Stored onboard and delivered to a port reception facility or treated onboard with an oil water separator
Oily residues (sludge)	Stored onboard and delivered to a port reception facility
Tank washings (slops)	N/A
Sewage	Treated onboard with a USCG-certified Marine Sanitation Device and discharged overboard or delivered to a port reception facility
Plastics	Stored onboard and delivered to a port reception facility
Food wastes	Stored onboard and delivered to a port reception facility or discharged overboard in accordance with US regulations
Domestic wastes	Stored onboard and delivered to a port reception facility
Cooking oil	Stored onboard and delivered to a port reception facility
Incinerator ashes	N/A
Operational wastes	Stored onboard and delivered to a port reception facility
Cargo residues	N/A

<sup>a</sup> Solid and liquid waste categories are based on waste categories provided in Annexes I, II, IV, and V of MARPOL

All vessels will comply with USCG standards in U.S. territorial waters to legally discharge uncontaminated ballast and bilge water, and standards regarding ballast water management. Outside of U.S. territorial waters, vessels will be compliant with the IMO Ballast Water Management Convention standards. Vessels will observe

the 3-nm No-Discharge Zone and will be equipped with a USCG-certified Marine Sanitation Device for treatment of sewage if the vessel is to discharge treated effluent outside of the 3-nm No-Discharge Zone.

### 8.2.2 Onshore Wastes

Wastes associated with the onshore portion of the Project include solid trash, drilling solids, drilling muds, and stormwater. All wastes generated shall comply with the applicable state and federal regulations, including but not limited to the Resource Conservation and Recovery Act and Department of Transportation (DOT) Hazardous Materials regulations. Ocean Wind's instructions for handling waste offshore where it is generated and onshore where it is stored and coordinated for pickup and disposal are provided in Appendix B. Ocean Wind is likely to use a site-specific Waste Management Register to identify, profile, categorize, and coordinate each waste stream. Where feasible, Ocean Wind will reduce waste and recycling as well as set waste reduction goals to minimize its waste generation.

During construction of the onshore substations, waste material would be disposed of in an appropriate licensed disposal facility and/or recycling center. In addition, drilling solid and liquid wastes generated by trenchless installation for each of the onshore routes would be disposed of in an appropriate licensed landfill and/or recycling center. There is potential for trench materials excavated during installation of the onshore cables to be disposed of depending on the properties of soil materials. The amounts of trenched material to be disposed of is dependent on final design and the results of subsurface soil investigations. A Licensed Site Remediation Professional will be retained to develop management for any contaminated soils (see Volume II Section 2.1.1). Stormwater that collects on the onshore portions of the Project during construction will be addressed in the construction Stormwater Pollution Prevention Plan, which Ocean Wind will develop and submit for approval by appropriate agencies prior to construction and once final design is completed. Stormwater that collects on either onshore substation site will be directed to a stormwater management basin and discharged, or alternative solution in agreement with the relevant agencies. Anticipated stormwater discharge amounts are dependent on final substation design and engineering.

Solid and liquid wastes generated during decommissioning would be dependent on the plans for the onshore facilities at the end of Project's operational life. Decommissioning of the onshore portions of the Project would occur in accordance with a detailed Project decommissioning plan that will be developed in compliance with applicable laws, regulations, and best management practices at the time. Solid and liquid wastes will be disposed of in accordance with New Jersey regulations and standards.

## 9. Other Information

### 9.1 Design Standards

Ocean Wind will follow a "design-basis" approach, whereby the project design criteria and standards to apply are outlined and justified. The proposed approach utilizes the project certification structure in the IECRE OD-502 Project Certification Scheme<sup>10</sup> as a baseline for establishing the design criteria and fulfilling the requirement for a BOEM-approved CVA to monitor the Project. Any requirements from BOEM are added on top of this structure.

Ocean Wind will apply the approach specified in IECRE OD-502 and outlined in the CVA Scope of Work provided as part of the CVA nomination. The Project development will follow the following general stages:

Site Conditions Assessment

---

<sup>10</sup> International Electrotechnical Commission System for Certification to Standards Relating to Equipment for Use in Renewable Energy Applications (IECRE).

- Design Basis Evaluation
- Design Evaluation
- Manufacturing Surveillance
- Transportation and Installation Surveillance

The detailed list of codes and standards for the Project will be presented during the Design Basis Evaluation, during which design, manufacturing, and transportation philosophies, assumptions, and site-specific design criteria based on site assessment data are documented for the design of all major Project components - including wind turbines, offshore support structures, electrical service platforms (offshore substations), and subsea cables. This documentation will be reviewed, commented upon, verified, and approved by the CVA before commencing with the detailed design activities for the Project. Each of the major components will produce a design basis document package, which will form a part of the final FDR/FIR submission to BOEM. This design basis package will list the codes and standards along with specific Ocean Wind requirements, general design philosophies, and site-specific design criteria and assumptions.

Conceptual plans and drawings, in addition to those provided above in Volume I are provided in Appendix U.

## 10. References

- Bureau of Ocean Energy Management (BOEM). 2021. United States Department of the Interior, Bureau of Ocean Energy Management Office of Renewable Energy Programs. Guidelines for Lighting and Marking of Structures Supporting Renewable Energy Development. April 2021.  
<https://www.boem.gov/sites/default/files/documents/renewable-energy/2021-Lighting-and-Marking-Guidelines.pdf>. Accessed April 2022.
- Bureau of Ocean Energy Management (BOEM) 2019. Draft Proposed Guidelines for Providing Information on Lighting and Marking of Structures Supporting Renewable Energy Development. October 2019.  
Retrieved from: <https://www.boem.gov/sites/default/files/documents/renewable-energy/Lighting-and-Marking-Guidelines.pdf>.
- Bureau of Ocean Energy Management (BOEM). 2018. Draft Guidance Regarding the Use of a Project Design Envelope in a Construction and Operations Plan. Bureau of Ocean Energy Management. Sterling, VA.
- Federal Aviation Administration (FAA). 2018. Advisory Circular No.70/7460-1L. Obstruction Marking and Lighting. Available online: [https://www.faa.gov/documentlibrary/media/advisory\\_circular/ac\\_70\\_7460-1l\\_-\\_obstruction\\_marking\\_and\\_lighting\\_-\\_change\\_2.pdf](https://www.faa.gov/documentlibrary/media/advisory_circular/ac_70_7460-1l_-_obstruction_marking_and_lighting_-_change_2.pdf). Accessed July 2019.
- Hornsea Project Three (Hornsea 3). 2018. Hornsea Project Three Offshore Wind Farm Environmental Statement: Project Description. May 2018.
- IALA. 2013. IALA 0-139, The Marking of Man-Made Offshore Structures, December 2013. Available online: <https://www.iala-aism.org/product/markings-of-man-made-offshore-structures-o-139>. Accessed July 2019.
- U.S. Coast Guard (USCG) 2005. Aids to Navigation Manual- Administration, COMDTINST M16500.7A. Available online: [https://media.defense.gov/2017/Mar/29/2001724016/-1/-1/0/CIM\\_16500\\_7A.PDF](https://media.defense.gov/2017/Mar/29/2001724016/-1/-1/0/CIM_16500_7A.PDF). Accessed July 2019.