

SANTA CLARA UNIT
AMENDED PLAN OF DEVELOPMENT
LEASE OCS P-0216



PUBLIC INFORMATION

UNION OIL COMPANY OF CALIFORNIA

NOVEMBER 30, 1979

APPENDIXES

- A. Field Rules for Drilling Procedures and Well Designs
- B. Summary of Industry Guidelines Necessary for Compliance with OCS Order No. 5
- C. Contingency Plan for H₂S and SO₂
- D. Oil Spill Contingency Plan

APPENDIX A

FIELD RULES
FOR
DRILLING PROCEDURES
AND
WELL DESIGNS

UNITED STATES
DEPARTMENT OF THE INTERIOR
GEOLOGICAL SURVEY
CONSERVATION DIVISION
WESTERN REGION
PACIFIC AREA

FIELD DRILLING RULES FOR DEVELOPMENT WELLS
TOTAL VERTICAL DEPTH BELOW MUD LINE 10,000 FEET (3048 METERS),
SANTA CLARA UNIT, LEASE OCS P-0217,
PLATFORM GRACE, OFFSHORE CALIFORNIA

These field drilling rules are established pursuant to the authority prescribed in 30 CFR 250.11 and in accordance with 30 CFR 250.34, 250.41 and 250.91. All development wells to a true vertical depth (BOF) not to exceed 10,000 feet (3048 meters) from Platform Grace, Lease OCS P-0217, shall be drilled in accordance with the provisions of these rules and in accordance with the provisions of OCS Order No. 2, Pacific Area, that are not in conflict herewith. Each Application for Permit to Drill (Form 9-331C) for development wells from this platform shall include all information required under 30 CFR 250.91 and the integrated casing, cementing, mud, and blowout prevention program for the well, and shall comply with the following requirements. Any departure from these requirements must be approved by the Supervisor pursuant to 30 CFR 250.12(b)(1).

- I. WELL CASING AND CEMENTING. All development wells shall be cased and cemented in accordance with the requirements of 30 CFR 250.41(a)(1). Each Application for Permit to Drill (Form 9-331C) shall contain a statement that all zones which contain oil, gas or fresh water shall be fully protected by casing and cement. Each Application for Permit to Drill shall also contain the casing strings to be installed and the setting depths required as set out below. All depths refer to true vertical depth below the ocean floor (TVD-BOF). After each casing string is set, pressure tests shall be conducted after drilling the casing shoe to determine that casing annular seals are competent.

A. Drive or Structural Casing.

This casing string will be set between 200' (61 meters) - 500' (152 meters) and cemented to the ocean floor.

B. Conductor Casing.

None required.

C. Surface Casing.

1. Pico-Repetto and Monterey Zones completions.

This casing string shall be set between 1000' (305 meters) and 2500' (762 meters). The casing shall be cemented with

a volume sufficient to return cement to the ocean floor. Actual setting depths for the surface casing shall be according to the following table:

<u>Minimum Depth of Drive or Structural Pipe</u>	<u>Maximum Depth of Surface Pipe</u>
200' (61 meters)	1000' (305 meters)
300' (91 meters)	1500' (457 meters)
400' (122 meters)	2000' (610 meters)
500' (152 meters)	2500' (762 meters)

D. Intermediate Casing.

1. Pico-Repetto Zones Completion.

None

2. Monterey Zone Completion.

The intermediate casing string shall be set at 3500' (1067 meters) but may be set as deep as 5000' (1524 meters) when a minimum of 1500' (457 meters) of surface casing has been set.

E. Protective Casing.

1. Pico-Repetto Zones Completion.

This protective casing string shall be set a minimum of 3500' (1067 meters) but may be set as deep as 5000' (1524 meters) when a minimum of 1500' (457 meters) of surface casing has been set. The casing shall be cemented with a volume of cement sufficient to fill the annular space from the casing shoe to a minimum of 200' (61 meters) into the next larger casing string.

2. Monterey Zone Completion.

This string shall be set between 6500' (1981 meters) and 8000' (2438 meters); below the abnormal pressure Pliocene sands but in any case, above the fractured Monterey Zone. This string shall either be a blank liner or a full string to the surface. The liner shall be cemented with sufficient volume of cement to fill opposite the entire length of the liner. The liner shall be set and tested in accordance with OCS Order 2.1.E. The full casing string shall be cemented with sufficient volume to fill the annular space from the casing shoe to at least 500' (152 meters) above the shallowest uncased hydrocarbon zone.

- F. Production Casing. This casing shall be set at the appropriate depth before completing the well for production. This casing shall be cemented in a manner necessary to cover or isolate all zones which contain hydrocarbons and a volume of cement sufficient to fill the annular space at least 500' (152 meters) above the uppermost hydrocarbon zone shall be used. When a blank or combination liner is run as production casing and the lap is cemented, the testing and minimum length of the lap between the liner top and the next larger string shall be conducted as specified for protective liners in OCS Order No. 2. The surface casing shall never be used as production casing.
- G. Pressure Testing. Prior to drilling the plug after cementing, all casing strings, except those which are installed by driving, shall be pressure tested and recorded on the driller's logs, as prescribed in OCS Order No. 2.1.H.
- II. BLOWOUT PREVENTION EQUIPMENT. Blowout prevention equipment shall be installed and maintained ready for use on all casing strings as prescribed in OCS Order No. 2. Blowout preventers shall be tested and auxiliary equipment shall be provided as described in OCS Order No. 2.
- III. MUD PROGRAM. The characteristics, use, and testing of drilling mud and the conduct of related drilling procedures shall be such as are necessary to prevent the blowout of any well and shall follow the requirements prescribed in OCS Order No. 2.

These field drilling rules may be changed upon application by the operator and approval by the Supervisor; to prescribe different setting depths for any casing string; to add or delete any casing string as experience, then existing conditions, or additional safety requirements may dictate; or to change the requirements for blowout prevention equipment and mud programs.

These field drilling rules shall be reviewed by the Supervisor at least once each year and changed as may be necessary to assure that all development wells drilled from Platform Grace will be drilled in a manner which will protect the natural resources of the OCS and result in the maximum economic recovery of the mineral resources in a manner compatible with sound conservation practices.

Effective Date: Nov. 1, 1978

Date Issued: Oct. 13, 1978

(Original signed by)
F. J. Schambeck
Oil and Gas Supervisor
Pacific Area

APPENDIX B

SUMMARY OF INDUSTRY GUIDELINES
NECESSARY FOR COMPLIANCE WITH
OCS ORDER NO. 5

SUMMARY OF INDUSTRY GUIDELINES NECESSARY FOR COMPLIANCE WITH
OUTER CONTINENTAL SHELF ORDER NO. 5

SAFETY FEATURE	SPECIFICATION *	RECOMMENDED PRACTICE	TESTING	COMPLIANCE
<u>SUBSURFACE SAFETY VALVE</u> (GENERAL)				
	API Spec 14A, 3rd Ed, 11/78	API RP 14B, 1st Ed, 10/73		1. Purchase SSSV equipment in compliance with RP 14A and SPPE-1.
1. Subsurface controlled	API Spec 14A, 3rd Ed, 11/78	API RP 14B, 1st Ed, 10/73	API RP 14B, Sub-section 2.9	2. Maintain records of location and history.
2. Surface controlled	API Spec 14A, 3rd Ed, 11/78	API RP 14B, 1st Ed, 10/73	API RP 14B, Appendix E	3. Conduct inspections and tests as rec'd by RP 14B. 4. Installing, operating, and maintaining as rec'd by RP 14B. 5. Reporting equipment failures to the manufacturer, API and USCS.
<u>PLATFORM PRODUCTION SAFETY SYSTEMS (GENERAL)</u>				
		API RP 14C, 2nd Ed, 1/78 (except Section A9, "Pipelines")		
1. Wellhead surface safety valve	API Spec 14D, 2nd Ed, 11/77 (Supplement 1, 1978)		API Spec 14D; Section 4; Appendix G	1. Purchase WSSV's in compliance with Spec 14D and SPPE-1. 2. Maintain records of location & history. 3. Conduct tests and inspections as rec'd by Spec 14D. 4. Install, operate, and maintain as rec'd by Spec 14D. 5. Report failures to the manufacturer, API and USCS.

*All SPPE shall conform to ANSI/ASME SPPE-1-1977 and SPPE-2-1977.

SUMMARY OF INDUSTRY GUIDELINES NECESSARY FOR COMPLIANCE WITH
OUTER CONTINENTAL SHELF ORDER NO. 5

SAFETY FEATURE	SPECIFICATION *	RECOMMENDED PRACTICE	TESTING	COMPLIANCE
PLATFORM PRODUCTION				
SAFETY SYSTEMS (GENERAL)				
Continued				
2. Flow diagram and SAFE chart		API RP 14C, Figure E1 API RP 14C, Subsection 4.3C		Organize according to RP 14C.
3. Pipelines				
A- Materials/ dimensions	ANSI B 31.4 ANSI B 31.8			Purchase or specify pipe in compliance with ANSI specifications.
B- Safety systems		API RP 14C		Design or specify safety systems as per RP 14C. Inspect as recommended.
- gas	ANSI B31.8			
C- Welding	API Std 1104, Sec 2 ASME Code, Sec IX	API RP 1111, Sec 5		Train or have welder certified to ASME and API standards.
- welder qualification	API Std 1104, Sec 3 ASME Code, Sec IX	API RP 1107, Sec 3		
- design/preparation	API Std 1104, Sec 4			
- acceptability	API Std 1104, Sec 6	API RP 1107, Sec 6		
- radiographic inspection	API Std 1104, Sec 8			
- repairs/defects	API Std 1104, Sec 7	API RP 1107, Sec 7		
- automatic welding	API Std 1104, Sec 9			
- maintenance		API RP 1107, Sec 4		
- inspection/testing	API Std 1104, Sec 5			

*All SPPE shall conform to ANSI/ASME SPPE-1-1977 and SPPE-2-1977.

SUMMARY OF INDUSTRY GUIDELINES NECESSARY FOR COMPLIANCE WITH
OCEAN CONTINENTAL SHELF ORDER NO. 3

SAFETY FEATURE	SPECIFICATION *	RECOMMENDED PRACTICE	TESTING	COMPLIANCE
PLATFORM PRODUCTION GAS LIFT SYSTEMS (CONTRACT) Continued				
D- Design				
- pressure		API RP 14E API RP 1111, Sec 202	API RP 1111, Sec 6 API RP 1110	Design or specify piping as rec'd by RP 14E.
- temperature	ANSI B31.8 841.1	API RP 1111, Sec 200.3		Design or specify as rec'd by ANSI.
- expansion/ flexibility	ANSI B31.4 419 ANSI B31.8 832 & 833			Design or specify as rec'd by ANSI.
- supports	ANSI B31.4 421 ANSI B31.8 834 & 835			Design or specify as rec'd by ANSI.
- auxiliary piping	ANSI B31.4 ANSI B31.8			Design or specify as rec'd by ANSI.
E- Corrosion Control				
		NACE RP-06-75 NACE RP-01-75 API RP 1111, Sec. 8		Design or specify as rec'd by NACE. Inspect as rec'd by NACE and API.
4. Area Classification Electrical Inst.		API RP 5005, 2nd Ed, 7/73		Design or specify according to RP 5005.
5. Fire & Gas Detectors	National Electrical Code 1975 Ed, Article 760	API RP 14C, 1st Ed, 9/78 Section 4, Appendix A; Section 3.2g	API RP 14C, Sec 7	1. Purchase detectors in compliance with NEC. 2. Install, operate, and maintain as per RP 14C.
6. Pressure Vessels (Coded)	ASME Boiler & Pressure Vessel Code	API RP 14C, Section A4		1. Purchase vessels in compliance with ASME code. 2. Install, operate, and maintain as per RP 14C.

*All SPPE shall conform to ANSI/ASME SPPE-1-1977 and SPPE-2-1977.

SUMMARY OF INDUSTRY GUIDELINES NECESSARY FOR COMPLIANCE WITH
OCTER CONTINENTAL SHELF ORDER NO. 3

SAFETY FEATURE	SPECIFICATION *	RECOMMENDED PRACTICE	TESTING	COMPLIANCE
<u>PLATFORM PRODUCTION</u>				
<u>SAFETY SYSTEMS (GENERAL)</u>				
Continued				
A- Pressure Relief Valves	ASME Code, Sections I, IV, VIII			<ol style="list-style-type: none"> 1. Purchase relief valves in compliance with ASME codes. 2. Install, operate, and maintain as per ASME.
B- Steam Generators	ASME Code, Sections I, IV	API RP 14C, Section A6		<ol style="list-style-type: none"> 1. Purchase steam generators in compliance with ASME code. 2. Install, operate, and maintain as per RP 14C.
7. Flow Lines		API RP 14C, Section A1 API RP 14E		Design or specify and install, operate, and maintain as per RP 14C and RP 14E.
8. Pressure Sensors		API RP 14C, Sections 2,3,4 OCS Order 3, Para. 5.1.2		<ol style="list-style-type: none"> 1. Purchase sensors in compliance with RP 14C. 2. Install, operate, and maintain as per RP 14C.
9. Emergency Shutdown System		API RP 14C, Section G1		Install, operate, and maintain as per RP 14C.
10. Engine Exhausts		API RP 14C, Subsect. 4.2C(4)		Install, operate, and maintain as per RP 14C.
11. Glycol Dehydration Units		API RP 14C, Section A6 API RP 14C, Subsect. A7.2b(1), A7.3a, A7.3c.		<ol style="list-style-type: none"> 1. Purchase dehydration unit in compliance with RP 14C. 2. Install, operate, and maintain as per RP 14C.

*All SPPE shall conform to ANSI/ASME SPPE-1-1977 and SPPE-2-1977.

SUMMARY OF INDUSTRY GUIDELINES NECESSARY FOR COMPLIANCE WITH
OUTER CONTINENTAL SHELF ORDER NO. 5

SAFETY FEATURE	SPECIFICATION *	RECOMMENDED PRACTICE	TESTING	COMPLIANCE
PLATFORM PRODUCTION SAFETY SYSTEMS (GENERAL) Continued				
12. Gas Compressors				
A- New		API RP 14C, Section A8		1. Purchase or modify gas compressors in compliance with RP 14C.
B- Existing		If enclosed by shelter, exclude from API RP 14C, Subsection A8.3b and A8.3d.		2. Install, operate, and maintain as per RP 14C.
C- Small (745 Kw or less)		Exclude from API RP 14C, Subsection A8.3d.		
13. Fire Fighting Systems				
		API RP 14C, 1st Ed, 9/78, Subsection 5.2.		1. Purchase system in compliance with RP 14C. 2. Install, operate, and maintain as per RP 14C.
14. Electrical Equipment				
A- Motors, lighting	National Electrical Code (1975)	API RP 500B API RP-14F, Sections 5,7		1. Specify and purchase electrical equip. in compliance w/NEC and IEEE Stds.
B- Wiring	National Electrical Code (1975) IEEE Std 45-1977	API RP 14F, Section 4		2. Install, operate, and maintain as per RP 14F.
15. Erosion				
		OCS Order 5, Paragraph 5.1.11		

*All SPPE shall conform to ANSI/ACME SPPE-1-1977 and SPPE-2-1977.

SUMMARY OF INDUSTRY GUIDELINES NECESSARY FOR COMPLIANCE WITH
OUTER CONTINENTAL SHELF ORDER NO. 5

SAFETY FEATURE	SPECIFICATION *	RECOMMENDED PRACTICE	TESTING	COMPLIANCE
<u>WELDING PROCEDURES</u>	National Fire Protection Association No. 518, 1971	API RP 14E, Subsection 8.3 OCS Order 5, Paragraph 5.4		Conduct welding procedures in compliance with NFPA code and RP 14E.
<u>SAFETY DEVICE SYSTEMS (GENERAL)</u>			API RP 14C, App D OCS Order 5, Paragraph 5.3	1. Inspect and test safety devices as rec'd by RP 14C. 2. Report failures to manufacturer, API and USCS.
1. Surface Safety Valves			API RP 14C, Sect D4, Table D2, Subsection L, Subsection M	
2. Flowline Safety Valves			API RP 14C, Sect D4, Table D2, Subsection D	
<u>SAFETY DEVICE TRAINING</u>		API RPT-2, 10/75		Train employees as rec'd by RPT-2.
<u>FAILURE AND INCIDENT INVESTIGATION SYSTEM</u>		ANSI/ASME SPPE-1-1977, Appendix III OCS Order 5, Paragraph 6		Maintain FIRS as specified by SPPE-1.
<u>CRANE OPERATIONS</u>	API Spec 2C, 2/72	API RP 2D, 10/72	API RP 2D, Sect 3	1. Purchase cranes in compliance with spec 2C. 2. Conduct inspections & tests as per RP 2D. 3. Install, operate, and maintain as per RP 2D.

*All SPPE shall conform to ANSI/ASME SPPE-1-1977 and SPPE-2-1977.

SUMMARY OF INDUSTRY GUIDELINES NECESSARY FOR COMPLIANCE WITH
 OUTER CONTINENTAL SHELF ORDER NO. 5

SAFETY FEATURE	SPECIFICATION #	RECOMMENDED PRACTICE	TESTING	COMPLIANCE
<u>EMPLOYEE ORIENTATION</u>		API RE I-1, 1/74		Train and motivate employees as rec'd by RP I-1.
<u>EMPLOYEE SAFETY PROGRAM</u>		API Bulletin T-5, 9/74		Train and motivate employees as rec'd by API Bulletin T-5.
<u>EMPLOYEE TRAINING AND QUALIFICATION IN WELL CONTROL EQUIPMENT</u>		API RPT-3, 1st Ed, 7/76		Train employees as rec'd by RPT-3.

SUMMARY OF INDUSTRY GUIDELINES NECESSARY FOR COMPLIANCE WITH
 OUTER CONTINENTAL SHELF ORDER NO. 7

	GUIDELINE	PERMIT COMPLIANCE
<u>LIQUID DISPOSAL (GENERAL)</u>	40 CFR 110 40 CFR 112.7 40 CFR 122.16 CWA - 301(b)(2)(F)	40 CFR 122.20 40 CFR 122.21 Liquids will be disposed of as recommended. Discharges will be monitored for oil content. Facilities will be inspected for leaks and unusually large quantities of oil or oil-containing liquids. Accidents will be reported to Company supervisor.
1. Drilling Mud Components	40 CFR 112.7(e)(5-7) 40 CFR 435.12	
2. Hydrocarbon Handling Equipment	40 CFR 112.7(e)(2-7) 40 CFR 435.12	
3. Curbs, Gutters, Drains	40 CFR 112.7(e)(1) 40 CFR 122.45 40 CFR 435.12	
4. Discharges from Fixed Platforms	40 CFR 110. 40 CFR 112.7(e) 40 CFR 435.12	
<u>SOLID MATERIAL DISPOSAL (GENERAL)</u>	40 CFR 122.16	40 CFR 122.20 40 CFR 122.21 Solids will be disposed of as recommended. All accidents will be reported to Company supervisor.
1. Well Solids	40 CFR 435.12	
2. Containers	OCS Order 7, Paragraph 1.2.2	
3. Equipment	OCS Order 7, Paragraph 1.2.3 In emergency, OCS #1, Paragraph 4	

SUMMARY OF INDUSTRY GUIDELINES NECESSARY FOR COMPLIANCE WITH
OUTER CONTINENTAL SHELF ORDER NO. 7

	GUIDELINE	PERMIT COMPLIANCE
<u>PERSONNEL</u>	API RP 7-7 API RP 7-3 API Bulletin 7-5	Train personnel as recommended; periodically review and test personnel in safety procedures recommended.
<u>POLLUTION INSPECTIONS</u>		
1. Manned Facilities	OCS Order 7, Paragraph 2.2.1	Inspect facilities as recommended. Make necessary repairs.
2. Unattended Facilities	OCS Order 7, Paragraph 2.2.2	Inspect facilities as recommended. Make necessary repairs.
<u>POLLUTION REPORTS</u>		
	33 CFR 153.203 OCS Order 7, Paragraph 2.3	Report spills to USCS & EPA as directed.
1. Spills	CWA Section 311 OCS Order 7, Paragraph 2.3.1.	Report spills to USCS & EPA as directed.
<u>PCE AND CONTINGENCY PLANS</u>		
1. Equipment and Materials	40 CFR 112, Section 112.7(c)	Maintain PCE as recommended by 40 CFR 112.
2. Oil Spill Contingency Plan	40 CFR 112 API Bulletin D16	Maintain SPCC Plan as directed. Provide copy of Plan to EPA as directed.
<u>DRILLS</u>	OCS Order 7, Paragraph 4 40 CFR 112.7(e)(10)	Hold pollution drills as recommended. Maintain records of drills. Submit time schedule of drill.
<u>TRAINING</u>	OCS Order 7, Paragraph 4.2 40 CFR 112.7(e)(13)	Train personnel as rec'd. Retain course completion certificates.
<u>SPILL CONTROL AND REMEDIAL</u>	OCS Order 7, Paragraph 5 API Bulletin D16 40 CFR 112	Take immediate corrective action as rec'd.

APPENDIX C

CONTINGENCY PLAN

FOR

HYDROGEN SULFIDE

AND

SULFUR DIOXIDE

APPENDIX C

CONTINGENCY PLAN FOR H₂S and SO₂

The following plan is prepared in the event formations are encountered that contain hydrogen sulfide while drilling wells on Platform Gilda. ALL personnel should be acquainted with this plan, whether they are regular workers on the drilling rigs, part-time workers, visitors, or short-term contractors.

This plan deals with hydrogen sulfide, since the only likely presence of sulfur dioxide would come from burning of gas with fractional concentrations of hydrogen sulfide. To avoid problems with SO₂, any intentional burning of formation gas will be done from the top of a flare extending ten feet above the highest working area occupied by personnel. In the event of an unintentional fire, there will be more important problems than sulfur dioxide to contend with, and all personnel will, for obvious reasons, work upwind of the fire source in an effort to contain and extinguish it.

GENERAL

H₂S is a poisonous gas. The degree of danger depends upon the concentrations in the air breathed. It should be remembered that changes in atmospheric conditions, wind, composition of a gas, etc., can quickly increase the concentration many times. Poor ventilation in enclosed spaces or buildings where gas may be leaking can cause the accumulation

of dangerous concentrations of H_2S . H_2S is colorless and 18% heavier than air and tends to accumulate close to the floor or ground in depressions, inside of firewalls, in manifold pits, in sumps, and above the roofs of floating roof tanks below the upper rim of the tank sides, or other unventilated and protected areas.

TOXIC EFFECTS OF H_2S

Concentration in PPM	Effect
0.1	Approximate odor threshold. Air pollution measurements require detection below this level.
10	Threshold Limit Value (TLV) Recommend maximum safe level for 8-hour exposure.
20	Current OSHA "ceiling" concentration. Respiratory irritation after long exposures. Possible eye irritation.
50	Current maximum allowable by OSHA up to 10 minutes per day if no other exposure exists. Respiratory protective equipment required at higher levels.
100	Coughing, loss of sense of smell, serious respiratory irritation if exposure is prolonged.
500	Unconsciousness within 2 minutes. Respiratory failure within 15 minutes.
1000	Immediately hazardous to life.

PHYSIOLOGICAL RESPONSE TO HYDROGEN SULFIDE

The serious and acute effects of hydrogen sulfide occur in the higher ranges of concentrations: 500 or more ppm. Breathing in this atmosphere results very quickly in unconsciousness and stoppage of respiration. If this occurs, artificial respiration will be required (in a fresh air area) within a very few minutes to preserve life. If respiration is restored promptly, no serious after-effects are expected from such an exposure. This points out the absolute necessity of having at least two people present where hydrogen sulfide is a possible contaminant.

Effects from exposures to concentrations in the range of 50 to 450 ppm are irritation of mucous membranes, eyes, and the respiratory tract. Although hydrogen sulfide can be detected by smell in concentrations of less than 1 ppm, exposure to 100 ppm for two to fifteen minutes and much shorter exposures at higher concentrations will deaden the olfactory nerves to the extent that hydrogen sulfide cannot be smelled at any concentration.

These effects are sufficiently uncomfortable (coughing, eye burn, throat irritation) that personnel familiar with the physiological response, can recognize the symptoms and remove themselves from the area of contamination. The maximum concentration in which an employee should work for a period of eight hours a day without respiratory protection is 20 ppm (OSHA Rules and Regulations Federal Register 10-18-72).

PERSONNEL SAFETY AND PROTECTION

All personnel shall undergo an eardrum examination before assignment to H₂S prone areas. Personnel with a perforated eardrum shall be prohibited from working in an H₂S environment.

The mud logger on duty will be monitoring hydrogen sulfide prior to and during the penetration of formations likely to contain hydrogen sulfide and shall alert the man in charge of operations at the first signs of hydrogen sulfide showing up in the mud.

Personnel will introduce caustic or other acceptable additives to the mud to reduce the possibility of sulfide stress cracking. All appropriate personnel will be instructed in the safe handling of such chemicals. Any gas from the mud logger's monitor shall be vented a safe distance outdoors. In addition, there will be sensors with alarms on the rig floor, at the shale shakers, in the living quarter areas, in the ventilation system supplying air to the lower decks, and near the floor in the lower deck areas where H₂S is most likely to collect so that people sleeping or at rest can be notified instantly of the attainment of concentrations of hazardous amounts of H₂S. The sensors will activate a visible and audible alarm when the concentration reaches 10 ppm in the ventilation system and living quarters and at all other positions except for an alarm setting of 20 ppm at the mud logger's monitor. Personnel shall proceed to a safe briefing area which is to be designated on the

Station Bill. When the level of H_2S reaches 20 ppm in the mud stream, two personnel equipped with self-contained breathing equipment will introduce caustic or other acceptable additives to the mud system to reduce this concentration. If it appears this concentration will spread to working or living areas, all nonessential personnel will evacuate the facility. Radio communication shall be used to alert helicopter and water craft in the immediate vicinity of the condition, and agencies listed at the end of this appendix.

There will be twenty (20) self-contained, pressure-demand breathing apparatus available for members of the working crew and supervisors so that an unexpected contamination of dangerous quantities of hydrogen sulfide can be corrected and placed under control by the crew in complete safety. These units will be equipped with 30 minute cylinders. Twenty eight (28) spare cylinders and three (3) cascade refill system manifolds will also be provided aboard the platform.

There will also be eighty (80) five-minute escape capsules available to equip outside contractors or other transients on the platform to protect themselves while leaving the premises. The escape capsules are not to be used for entering H_2S contaminated areas; they are supplied for escape purposes only.

Ropes, with safety harnesses to retrieve incapacitated personnel from contaminated areas, and a stokes litter or equivalent will be available for use on the platform.

A resuscitator with mask, oxygen bottle and spare oxygen bottle will be located in the drilling office.

A training program for all working personnel and supervisors will be conducted prior to penetration of the first zone of suspected hydrogen sulfide contamination. This program will assure that all workers will be familiar with the location and use of available equipment and understand the physiological effects of hydrogen sulfide. They will also be informed of the safety and alarm features on the platform and will be instructed in procedures that must be taken in the event of an emergency. This instruction will include the proper use of personnel safety equipment, the use of mechanical ventilation equipment, the location of briefing areas, identification of evacuation routes, and will also include the rapid instruction of outsiders (who could be present in an emergency) in the use of the escape capsules for their protection. All personnel in the working crew will be trained in basic first aid. During training sessions and drills, emphasis will be placed upon rescue and first aid for H₂S victims. The working crew will be trained in the use of the first aid equipment on board.

There will also be two movable blowers on the rig floor of sufficient size to enable the crew to create its own breeze and up-wind-areas in the event of a H₂S release during a dead calm. There shall be sufficient caustic soda aboard for rapid feeding into the mud stream to react with and nullify the effects of hydrogen sulfide should the mud become contam-

inated. A supply of reactive chemicals will be available for treating the mud to prevent the possibility of H₂S reforming.

Four portable Hydrogen Sulfide Detectors will be placed on board and distributed to areas where it may become necessary to determine the ambient concentrations of hydrogen sulfide at any time. These will be located at the following: 1 - rig floor, 1 - mud pumps, 1 - drilling office, 1 - production office. In the event of an alarm from any source, two men wearing self-contained breathing equipment will work as a team monitoring the hazardous areas with portable hydrogen sulfide detectors, and only when the monitoring equipment indicates safe levels of this gas may personnel remove breathing apparatus, or personnel without breathing apparatus, move into these areas once again.

FIRST AID

In case a man is overcome, summon the nearest help, put on self-contained breathing equipment, then immediately get the victim into the fresh air and proceed as follows:

- A. Apply mouth-to-mouth artificial respiration, without interruption, until the resuscitator is available.

Use the resuscitator until normal breathing is restored.

Symptoms may pass off rapidly; however, keep the victim warm, even during artificial respiration.

B. Summon a doctor as soon as possible.

C. Summon transportation if required by doctor. When the patient has recovered and can be safely moved, he must be sent to the hospital and never allowed to stand until released by the doctor.

NOTE: The man in charge of the working crew shall be in full charge of safety precautions and shall direct operations necessary to the safety and health of all people on the platform.

PROCEDURE FOR OPERATING CONDITIONS

Moderate Danger (10-20 ppm H₂S)

Three briefing areas have been designated. They are located

EAST SIDE OF DRILLING DECK

WEST SIDE OF DRILLING DECK

HELIPORT

If there is a steady breeze, the upwind area shall be the safe briefing area at any time. If there is no wind blowing, the movable blowers will be available to establish an upwind briefing area where necessary.

Under normal conditions, each operating crew should undergo a hydrogen sulfide drill each week, in conjunction with other drills required in offshore operations. Drills should acquaint personnel with the problem of putting on a self-contained breathing apparatus or an escape capsule, the use of movable blowers and the best approaches to their briefing areas and abandon platform stations. Records of attendance will be maintained aboard the platform.

At a fixed time each day, one member of the crew will check the alarm systems to see that they are functioning.

Extreme Danger (Over 20 ppm H₂S)

Operational danger signs (8' x 4') indicating "DANGER HYDROGEN SULFIDE H₂S will be displayed on each side of the platform, and a number of warning flags shall be hoisted in a manner visible to any water craft or aircraft that may be in the area.

When the level reaches 20 ppm H₂S in the working or living areas, all nonessential personnel will be evacuated as soon as possible, and all working people will put self-contained breathing apparatus on and move to the upwind briefing area for instructions. Movable blowers will be started, if required to establish an ample area of safety upwind of the source. Two men with self-contained breathing apparatus on and functioning, will add caustic to the mud, and survey the various working areas with H₂S detectors and report to the Supervisor of conditions throughout the platform. The Supervisor will then make the decision whether to set the crew to immediate corrective action with self-contained breathing apparatus on and functioning, or to evacuate as soon as possible. If the Supervisor wishes to make this decision at the beginning of the H₂S alert, we can dispense with the two-man survey.

RESPONSIBILITIES OF PERSONNEL

The Supervisor in charge of drilling operations at any time will also supervise the action to be taken in an H₂S emergency. One man in each crew shall be designated as the H₂S detector operator. He should be fully acquainted with its operation and be prepared to be the front-line man in putting on his self-contained breathing apparatus and testing the atmosphere at points directed by the Supervisor. One man shall also be designated in each crew to take over the Supervisor's position immediately, if the Supervisor should become incapacitated by hydrogen sulfide inhalation.

EVACUATION PLAN

The evacuation of personnel will follow the procedures set forth in the Coast Guard Station Bill.

AGENCY NOTIFICATION

The following agencies shall be immediately notified if hydrogen sulfide concentrations reach 10 ppm or above:

U.S. GEOLOGICAL SURVEY:

Mr. M. F. Reitz	Office 805-648-5131	Home 805-642-3043
or Mr. C. Dennis Rau	Office 805-648-5131	Home 805-642-2244
or Mr. R. O. Courtwright	Office 805-648-5131	Home 805-642-0825
or Mr. F. J. Schambeck	Office 213-688-2846	Home 213-861-5075

U.S. COAST GUARD:

805-487-9822

LISTING OF MEDICAL PERSONNEL AND FACILITIES

HOSPITALS

Cottage Hospital 320 West Pueblo Santa Barbara, California	(850) 963-1661
St. Francis Hospital 601 East Micheltorena Santa Barbara, California	(805) 962-7661 or 966-1531
Community Memorial Hospital of San Buenaventura 2800 Loma Vista Road Ventura, California	(805) 648-3201
St. John's Hospital 333 North "F" Street Oxnard, California	(805) 483-1141

DOCTORS

Santa Barbara Medical Clinic 215 Pesetas Lane Santa Barbara, California	(805) 964-6211
Ventura Medical Group 3003 Loma Vista Road Ventura, California	(805) 643-2161



AMBULANCE

Coastal Ambulance 1913 State Street Santa Barbara, California	(805) 963-3561
Courtesy-Ventura 3110 Loma Vista Road Ventura, California	(805) 643-5496
Oxnard Ambulance Service 321 South "C" Street Oxnard, California	(805) 486-6333

FIRE DEPARTMENTS

Santa Barbara City	(805) 965-5252
Ventura City	(805) 643-6121
Oxnard City	(805) 483-2211

POLICE DEPARTMENTS

Santa Barbara Police	(805) 965-5151
Santa Barbara Country Sheriff (Santa Barbara)	(805) 963-1611
Highway Patrol	Zenith 12000
Ventura County Sheriff	(805) 648-3311
Oxnard Police	(805) 486-1663

HARBOR MASTER

Santa Barbara	(805) 963-1737
Ventura	(805) 642-8538
Oxnard	(805) 487-5511

U. S. COAST GUARD

(805) 985-9822

HELICOPTERS

*Rotor-Aids	(805) 642-8347
	(805) 644-5903
*Condor	(805) 487-5451
	(805) 487-5389

*(Will depend on Contract Services)

APPENDIX D

OIL SPILL CONTINGENCY PLAN

FOR

SOUTHERN DISTRICT,

VENTURA AREA,

UNION OIL COMPANY

OF

CALIFORNIA

OIL SPILL CONTINGENCY PLAN

POLICY

The policy of Union Oil Company of California concerning environmental matters is to vigorously support conservation of natural resources in all operations. The Company will comply with, and wherever feasible exceed the regulations established by governmental agencies charged with pollution control. Operations are conducted to minimize air and water contamination and the most modern pollution control equipment is planned as an integral part of all facilities.

The Company will make every effort to prevent pollution of the ocean, and will cooperate with others in reporting, controlling and cleaning up spills of oil and liquid pollutants.

Union Oil Company of California retains the responsibility and authority for the direction and supervision of clean-up operations of spills occurring from facilities it operates.

Union Oil Company of California acknowledges its responsibility and delegates the authority for conducting response operations to its Oil Spill Response Coordinator for pollution and oil spills emanating from its facilities.

OIL SPILL RESPONSE PROCEDURES

Union Oil Company has established the following degrees of spill severity:

- Type I - Well blowout
- Type II - Marine pipeline failure
- Type III - Malfunction or rupture of production facilities (piping & vessels)
- Type IV - Minor spills (drainage system malfunctions, accidental discharges)

The Type I spill could be a major on-going spill requiring the full use of all available equipment. The Type II spill would be limited in volume and immediately controllable. All or part of the CSI equipment might be necessary for adequate control. The Type III spill would be in the minor category (10,000 gallons or less) and could be cleaned up with equipment maintained on the platform. Part of the CSI equipment would probably be used. The Type IV spill would normally be in the range of 100 gallons or less. In the Santa Barbara Channel, this type of spill will dissipate within minutes, therefore, prompt clean-up response is essential. Equipment maintained on the platform would be sufficient for this type of spill.

Upon discovery of an oil spill or unidentified spill, area management is first notified, who will then contact proper authorities and notify the Oil Spill Response Coordinator.

OIL SPILL NOTIFICATION
UNION OIL COMPANY PERSONNEL

CALL IN THIS ORDER:

1. Foreman on call - call the answering service at 805/643-8641 or 805/485-5523 and ask for Pager numbers as follow:
 - a. George Reed (Pager #0850)
11267 N. Oakcrest
Ojai, CA 93023 [REDACTED]
 - b. Robert Beattie (Pager #0851)
90 Watkins Way
Oak View, CA 93022 [REDACTED]
 - c. Robert Mounts (Pager #0852)
1300 Saratoga #2104
Ventura, CA 93003 [REDACTED]
2. Field Superintendent - Howard E. Henley
4819 Aurora
Ventura, CA 93003 [REDACTED]

Office: 5565 Carpinteria Ave
Carpinteria, CA 93013
(805/684-2513)
3. Area Production Superintendent - Gary E. Carlson
436 Morrison
Santa Paula, CA 93060 (Home - 805/525-1956)

Office: 1003 Main Street
Santa Paula, CA 93060
(805/525-6672)
4. District Production Superintendent - Richard C. Keller
2216 Vista Del Mar
Ventura, CA 93003 (Home - 805/643-0567)

Office: 2323 Knoll Drive
Ventura, CA 93003
(805/659-0130)
5. District Operations Manager - Ray M. Barnds
1076 Via Cielito
Ventura, CA 93003 (Home - 805/642-5027)

Office: 2323 Knoll Drive
Ventura, CA 93003
(805/659-0130)

OFFSHORE OIL SPILL NOTIFICATION
REGULATORY AGENCIES

CALL IN THIS ORDER:

1. U. S. Coast Guard

- a. National Response Number - 800/424-8802
- b. Notify one of the following local stations:

Santa Barbara
111 Harbor Way
Santa Barbara, CA 93109
805/962-7430

Channel Islands Harbor
4201 Victoria Avenue
Oxnard, CA 93030
805/985-9822

Long Beach
400 Ocean Gate
Long Beach, CA 90822
213/590-2225

2. U. S. Geological Survey

- a. Santa Barbara District Office
145 N. Brent
Ventura, CA 93003
24 hour telephone number - 805/648-5131

Mike Reitz
Denny Rau
Ray Courtright

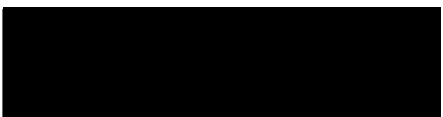

All spills of oil and liquid pollutants must be reported orally within 12 hours for spills less than 1 cubic meter (6.3 barrels), and without delay for spills greater than 1.0 cubic meter, to the District U. S. Geological Survey Supervisor and confirmed in writing.

All pollution reports shall include the following:

1. The cause.
2. Location.
3. Volume of spill.
4. Action taken.

Reports of spills of more than 5 cubic meters (31.5 barrels) must include

items 1-4 above and the following:

1. Sea state conditions.
2. Meteorological conditions.
3. Size and appearance of slick.

All spills of oil and liquid pollutants must be reported pursuant to 33 CFR 153.203.

SHORE SITE OIL SPILL NOTIFICATION
REGULATORY AGENCIES

CALL IN THIS ORDER:

1. U. S. Coast Guard

- a. National Response Number - 800/424-8802
- b. Notify one of the following local stations:

Santa Barbara
111 Harbor Way
Santa Barbara, CA 93109
805/962-7430

Channel Islands Harbor
4201 Victoria Avenue
Oxnard, CA 93030
805/985-9822

Long Beach
400 Ocean Gate
Long Beach, CA 90822
213/590-2225

2. State of California, Office of Emergency Services - 800/852-7550

All spills of oil and liquid pollutants must be reported pursuant to 33 CFR 153.203.

OIL SPILL RECOVERY AND DISPOSAL

In the event of an oil spill, Union Oil Company has established a response team capable of taking prompt corrective action in a spill situation. This team is led by the Oil Spill Response Coordinator, Mr. Ray M. Barnds, District Operations Manager. Response Team members are trained in their respective assignments. Specific Response Team assignments are listed in Figure 2.

An Oil Spill Response Center has been established at Union Oil Company's District Office, 2323 Knoll Drive, Ventura, CA 93003. It is felt that from this location, the Response Coordinator can best be in communication with platform personnel, clean-up supervisors and regulatory agencies. Union Oil Company has a well-established, company-operated, nationwide telephone system, as well as an extensive inventory of two-way, FM radios operating on frequencies exclusively assigned to Union Oil Company.

FIGURE 2
OIL SPILL RESPONSE TEAM

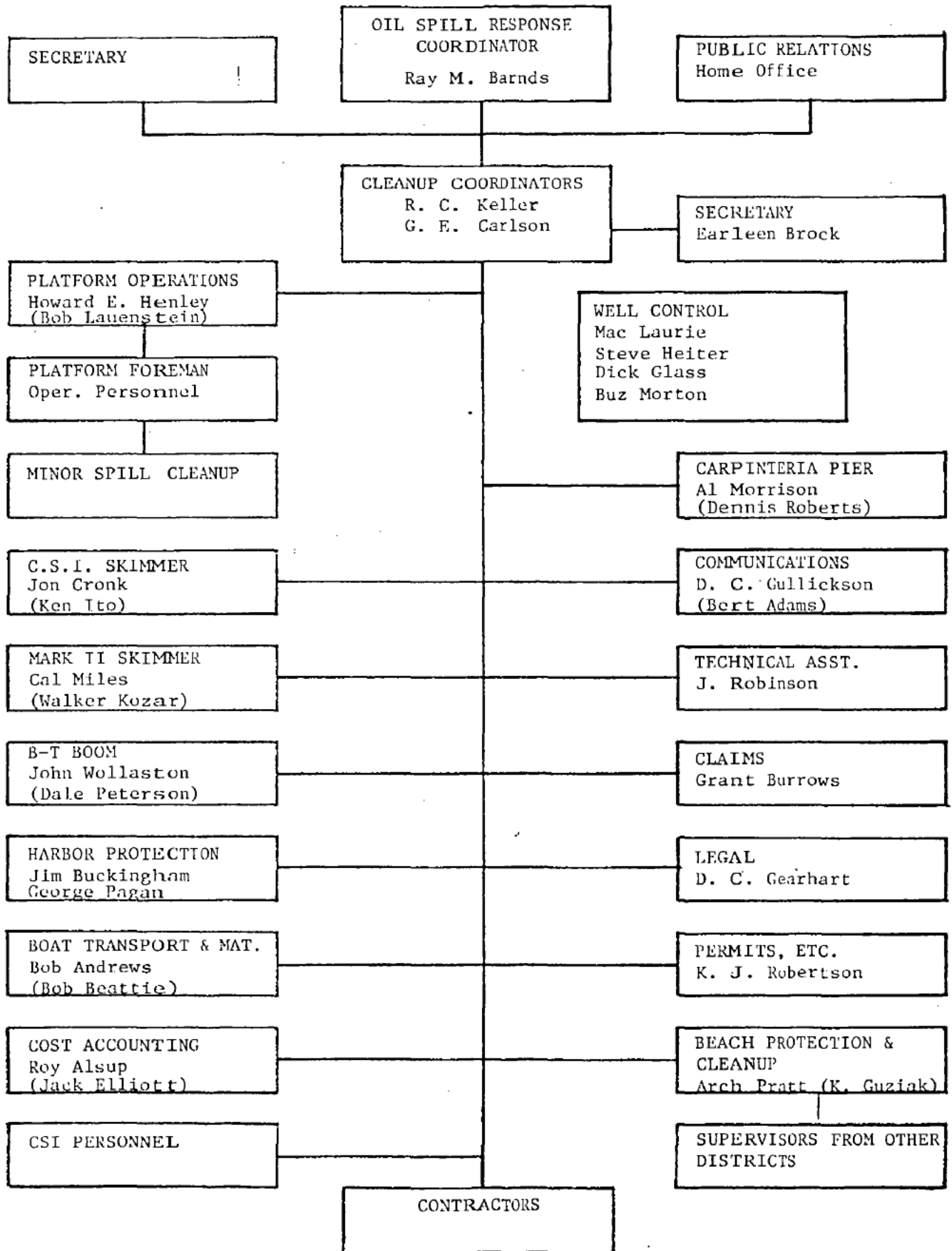

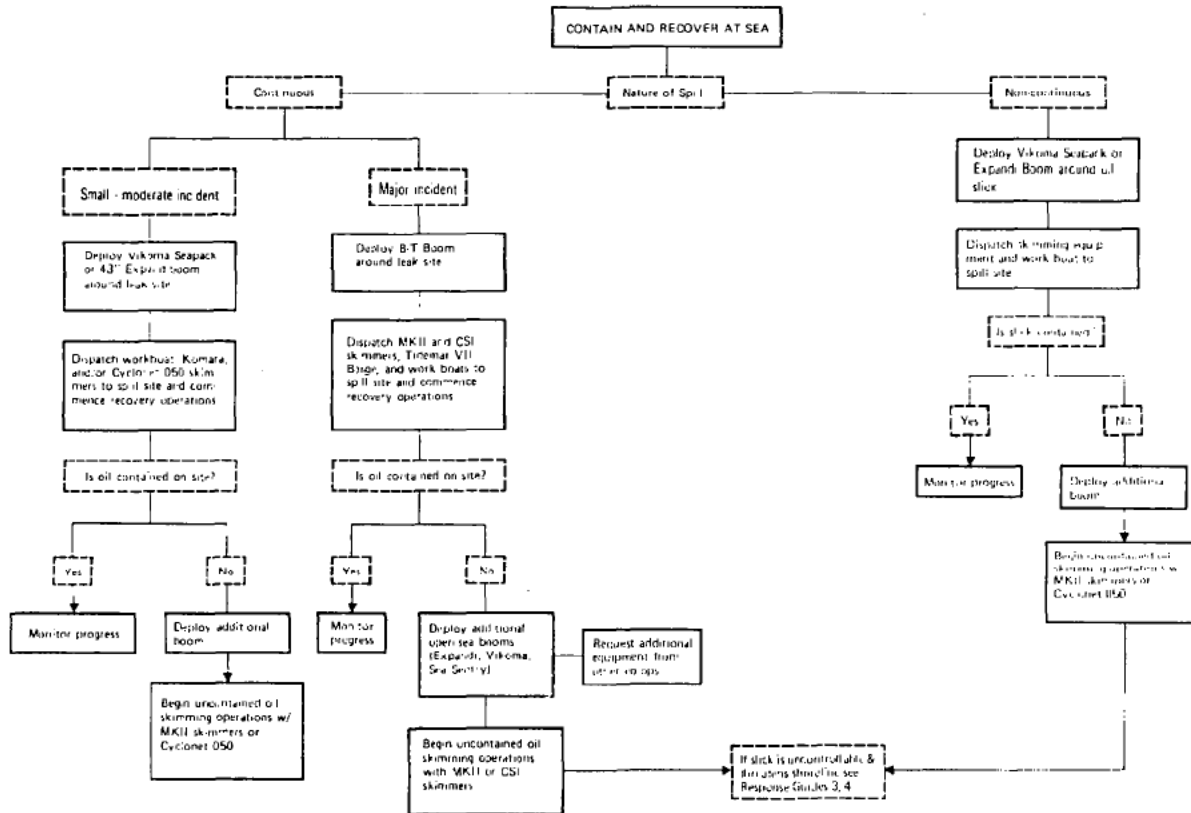

FIGURE 3

PERSONNEL

In addition to the personnel listed in the Organization Chart, four men working on the platforms have been trained as foremen and can be used either in the cleanup activity or as platform supervisors; thus, releasing the permanent foremen for cleanup work. Within twelve to twenty-four hours, supervisors from the other districts, as well as Home Office, Research, and Refinery personnel can be made available for the various jobs.

Clean Seas Incorporated personnel will be available. The C.S.I. manager and any other full-time employees will be used to mobilize and place in operation the various items of C.S.I. equipment.

Contractor-supplied labor forces will be used where deemed necessary.

DISPOSAL

Several disposal methods are available. They include oil and water separation, burial, and natural degradation. The specific disposal method selected depends on the nature of the oil-contaminated material, the location of the spill, and the prevailing weather conditions.

Every practicable effort will be made to recover spilled material. Oil/water mixtures can be separated in treatment tanks at local oil production facilities located along the Santa Barbara Channel coastline, and recovered oil can then be sent to a refinery.

Contaminated wastes, including sorbents, can be buried safely on land in Class I disposal sites if correct procedures are followed. It is advisable during waste handling, transfer, or storage to prevent contamination by covering the area of operation with plastic sheets.

In the event of any shoreline cleanup operation, establishing a temporary oily waste disposal site close to the cleanup operation is very important. The purpose of a temporary storage site is to provide a location to accumulate oily sediment and debris removed during shoreline cleanup operations until a final disposal site can be located, approved, and arrangements made for its use. The temporary storage sites should be located in an area with good access to the shoreline cleanup operation and to nearby streets and highways. Good storage site locations should be flat areas such as parking lots (paved or unpaved) or underdeveloped lots adjacent to the shoreline.

CLASS I DUMPS

SANTA BARBARA COUNTY

Casmalia Disposal (private site) 805/969-4703 or
Office: N.T.U. Road 925-1616
Casmalia, California Unit 208

Disposal site location:
West of Santa Maria, follow blacktop road,
turn right on N.T.U. Road.

VENTURA COUNTY

Carney and Sons Land Fill, Inc. 805/487-9176
5085 West Fifth
Oxnard, California

Simi Valley Landfill 805/522-1116

Disposal site location:
Near intersection of Brea Canyon and
State Highway 118 - can take Group I
liquids, sludges, and solid wastes on
Wednesdays 8 A.M. to 12 Noon only.

LOS ANGELES COUNTY

Calabasas Landfill 213/699-7414
Office: Los Angeles County Sanitation
Districts
2020 Beverly Boulevard
Los Angeles, CA 90057

Disposal site location: 213/885-1430
26919 West Ventura Freeway, Agoura, 1
mile west of Las Virgenes Road (west of
San Fernando Valley) - can take liquids,
sludges, and solid wastes.

Palos Verdes Landfill 213/699-7414
Office: same as Calabasas Landfill

Disposal site location: 213/772-2631 or
Southwest Los Angeles area, 26301 South 377-3514
Crenshaw, Rolling Hills - can take liquids,
sludges, and solid wastes.

West Covina Landfill 213/432-8461
Office: B.K.K. Corporation
3031 East "I" Street
Wilmington, California

Disposal site location: 213/965-2519
East Los Angeles, 2210 Azusa Avenue,
West Covina - can take liquids, sludges,
and solid wastes.

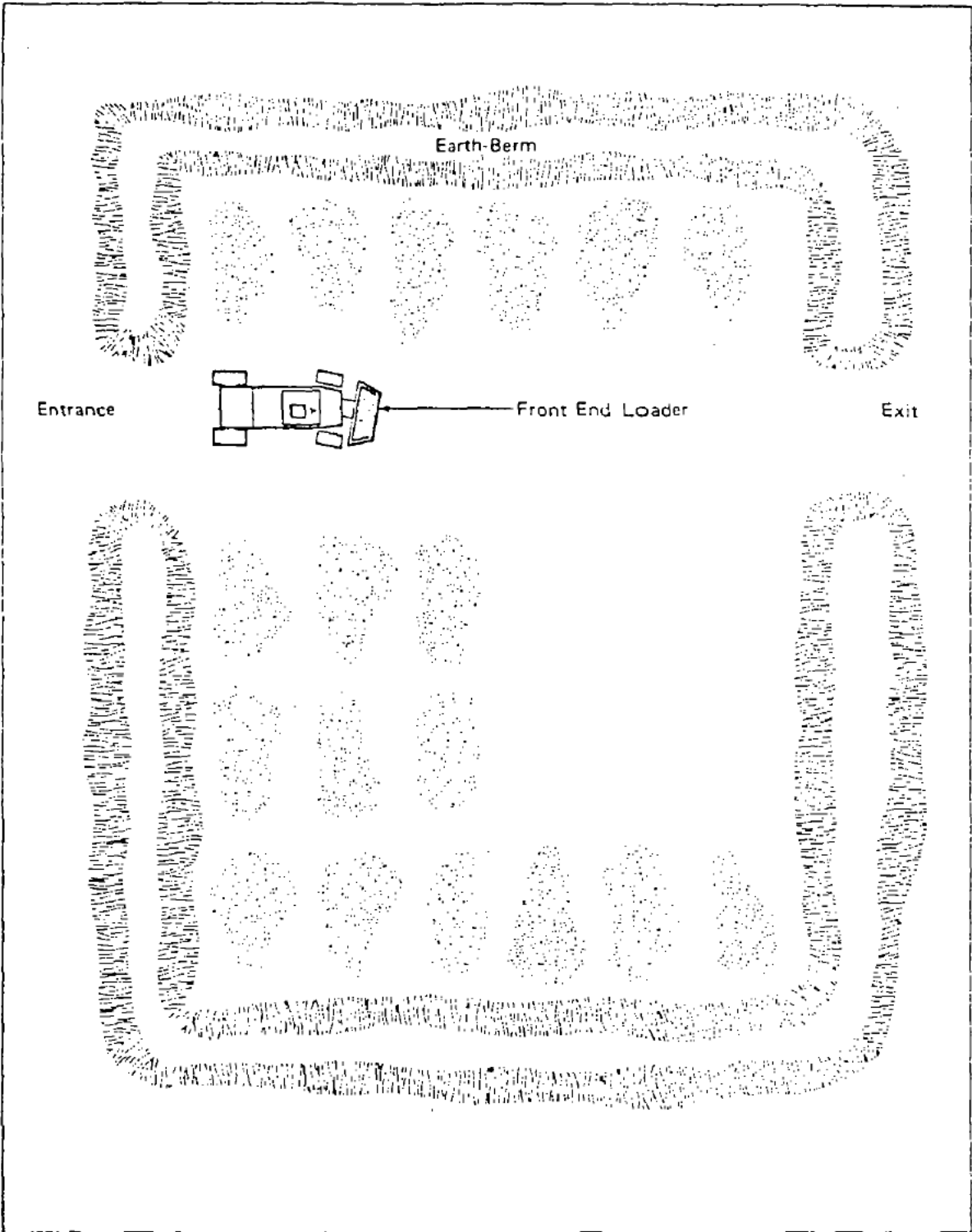

TEMPORARY WASTE STORAGE SITE

EQUIPMENT & SUPPLIES

Inventories of equipment and supplies are listed on the following pages. The inventories have been grouped into locally committed and uncommitted, and regionally committed and uncommitted categories. In addition to the equipment planned for the Ilucneme and Santa Clara OCS platforms, additional equipment will be placed aboard the platforms as required by the USGS Area Supervisor.

Nearly all of the equipment stored on Platforms A, B & C can be loaded on board a currently chartered crew boat for fast transportation to the proposed platform areas. Numerous Company owned vehicles equipped with 2-way radios are also available on short notice.

Much of the Clean Seas Incorporated (CSI) equipment is stored aboard trailer vans parked near selected harbors and beaches. Each van is selectively stocked with equipment best suited for that particular location. Deployment of this equipment requires very little time.

There are currently no plans to store large amounts of spill control or clean up materials at the onshore production processing facility. All equipment or materials needed in the event of an offshore emergency are readily accessible from nearby sources as described in the OSCP and the CSI Manual.

The onshore site is located in a sheltered, enclosed area, protected from sensitive habitat areas. The onshore site will, however, be equipped with routine clean up capability to control any possible upset conditions within the confines of the facility.

LOCALLY COMMITTED EQUIPMENT & MATERIALS
UNION OIL OWNED

ITEM	QUANTITY	DESCRIPTION	LOCATION	TIME/DEPLOYMENT **
1.	800'	Kepner 8" Sea Curtain oil containment boom, 12" skirt.	Platform A	2-1/2 hrs.
2.	800'	Kepner 8" Sea Curtain oil containment boom, 12" skirt.	Platform B	2-1/2 hrs.
3.	800'	Kepner 8" Sea Curtain oil containment boom, 12" skirt.	Platform C	2-1/2 hrs.
4.	1000'	Kepner 8" Sea Curtain oil containment boom, 12" skirt.	Platform Gilda*	20 min.
5.	1000'	Kepner 8" Sea Curtain oil containment boom, 12" skirt.	Platform Gina*	20 min.
6.	480'	3M Absorbent Boom	Platform B	
7.	3 boxes	Conwed Sorbent boom and sweeps	Platform Gilda*	15 min.
8.	3 boxes	Conwed Sorbent boom and sweeps	Platform Gina*	15 min.
9.	1	Watermaster skimming pump, Model 706-5, with hose & floating suction device, 5 hp gas engine.	Platform A	2-1/2 hrs.
10.	1	Watermaster skimming pump, Model 706-5, with hose & floating suction device, 5 hp gas engine.	Platform B	2-1/2 hrs.
11.	1	Watermaster skimming pump, Model 706-5, with hose & floating suction device, 5 hp gas engine.	Platform C	2-1/2 hrs.
12.	1	Acme oil skimmer, air driven with hoses & floats.	Port Hueneme	1-1/2 hrs.
13.	1	Acme 51T oil skimmer	Platform Gilda*	30 min.
14.	1	Acme 51T oil skimmer	Platform Gina*	30 min.
15.	1	17' Boston whaler boat, 70 hp outboard.	Platform B	4 hrs.
16.	1	12' Skiff with 9-1/2 hp outboard.	Platform A	2 hrs.
17.	1	Cummins diesel engine, Model V6-155-1F powering a Berkeley centrifugal pump, Model B3JQM, equipped with series 750-CS carbon steel deck gun and suction hose.	Casitas Pier	3 hrs.

LOCALLY COMMITTED EQUIPMENT & MATERIALS
UNION OIL OWNED

ITEM	QUANTITY	DESCRIPTION	LOCATION	TIME/DEPLOYMENT **
18.	1	Lister diesel engine, Model SR-4, powering a Pacific single stage pump, rated at 170 gpm and 150 psi, with one dispersant injector pump.	Port Hueneme	2-1/2 hrs.
19.	400'	Oil containment boom, continuous cylindrical bouy type, rubber coated canvas.	Port Hueneme	2-1/2 hrs.
20.	275 gal.	Exxon 9527 oil dispersant ***	Platform A	N/A
21.	275 gal.	Exxon 9527 oil dispersant ***	Platform B	N/A
22.	275 gal.	Exxon 9527 oil dispersant ***	Platform C	N/A
23.	550 gal.	Exxon 9527 oil dispersant	Platform Gina*	15 min.
24.	550 gal.	Exxon 9527 oil dispersant	Platform Gilda*	15 min.
25.	165 gal.	Polycomplex A-11 oil dispersant	Carpinteria Warehouse	2 hrs.

* -Equipment planned for Hueneme and Santa Clara OCS platforms

** -Represents time required to mobilize and arrive at either Platform Gina or Gilda.

*** -10 drum/platform requirement satisfied by onshore storage at CSI yard.

N/A -Not applicable

CSI EQUIPMENT STORED IN CARPINTERIA YARD

TOTAL NO.	EQUIPMENT
	<u>BOOMS</u>
1 - 1600'	Vikoma seapack
800'	8" Kepner
400'	16" Kepner
1210'	Sea Sentry (Goodyear)
2000'	B-T boom
	<u>SKIMMERS</u>
3	Floating weirs
1	Komara Mini
1	Cyclonet 050
2	Mark II (1 with 125 hp enging, 1 with 2 - 55 hp engines)
	<u>OIL MOPS</u>
1	400' 9" Mop & MK-II-9 machine
	<u>SORBENTS</u>
1 - Conwed	Booms (box)
74 - 3M Co.	Sheets (box)
6 - Conwed	Blankets (box)
3 - Conwed	Rugs (box)
1 - 3M Co.	Sweeps (box)
5	Oil snare (box)
76 - Dow	Imbiber blankets (box)
8 - Dow	Imbiber bags (box)
	<u>STORAGE BAGS</u>
1	1200 gallon
	<u>HOSE</u>
2	2" - 15' suc.
3	3" - 25' suc.
3	3" - 25' disc.
6	3" - 50' suc.
1	4" - 25' disc.
3	6" - 27' suc.
1	6" - 15' suc.
1	6" - 17' suc.
1	6" - 18' suc.
1	6" - 32' suc.
1	6" - 42' suc.

This equipment can be transported to an affected area in 4 hours.

CSI EQUIPMENT STORED IN CARPINTERIA YARD (cont'd)

TOTAL NO.	EQUIPMENT
	<u>ANCILLARY</u>
1	Vikoma power block w/2 ton coffering hoist and A-frame
2	B-T box w/air guns, tools, air hose
1	CSI skimmer box w/line, anchors, buoy, chains, tools
1	Mark II box w/2" line for mooring
1	2-1/2 ton F-600 truck
1	3/4 ton R-250 truck
1	15' aluminum boat w/15 hp Evinrude engine
1	19' boat w/70 hp Evinrude engine
6	Scare-Away w/propane
2	Air motor for B-T boom
4	100 bbl oil retention tank
2	100 bbl separating tank
2	Marlow pump (gas) 3"
1	Diesel 3" Stang pump
2	Wilden pump (M-15)
1	Homelite pump 192 (ballast)
1	Vikoma box w/line
1	Mark II box w/gas cans, line, slings, grease, tools
1	Cyclonet 050 box w/suction line, air pump, towing line, etc.

This equipment can be transported to an affected area in 4 hours.

VAN DESCRIPTIONS

CSI EQUIPMENT STORED IN VANS

VAN #1

CARPINTERIA YARD

800' 16" Kepner

400' 8" Kepner

Sorbents

Conwed

Booms 10 bx/24' ea

Sweeps 5 boxes

Rugs 2 rolls

Blankets 2 boxes

3M Company

Booms 10 bx/40' ea

Sweeps 2 bx/100' per

Dow

Bags 1 bx/100 per

Blankets 20 bx/1 per

Oil Snare 1 bx/30 ea

51T Acme skimmer w/1200 gal bag

3" 25' hose w/2" - 3" valves

3" 25' skimmer disc. hose

1 - 30' buoy line w/buoy

1/2" nylong, 3/4" nylon, 1/4" nylon

Floats/skimmers 5

Rakes 1

Pitchforks 2

Tools Misc

55 gallon drum 2

Anchors 3/40#, 1/22# 4

Anchor lines, 200' 1/2" nylon 4

Crown line w/buoy 200' 4

Towing bridle 5/8" wire 1

Chemical lights 15

Life preservers 4

Mops 5

This equipment could be transported to any affected area in 2 hours.

CSI EQUIPMENT STORED IN VANS

VAN #2

GETTY TERMINAL, GAVIOTA

800' 16" Kepner Boom

Sorbents

Conwed

Booms 10 bx/24' per

Sweeps 5 boxes

3M Company

Sheets 10 bx/100 per

Sweeps 2 bx/100' per

Dow

Blankets 20 bx/1 per

Oil Snare 1 bx/30 per

51T Acme skimmer w/5000 gal bag	
25' 3" hose w/30' 1/2" buoy line 2/buoy	1
Skimmer hose	2
100' 1/2" nylon, 100' 3/4" tow line	3
1000' 1/4" manila line	1 bx
Hose floats	5
Life preservers	4
Pitchforks	2
Rakes	1
Tools	Misc.
55 gallon drum	2 ea
Anchors 3/40#, 1/22#	4
Anchor line 200' 1/2" nylon	4
Crown line 200' 1/2" poly w/buoy	4
3" valve	2
Chemical lights	5

This equipment could be transported to any affected area in 3 hours.

CSI EQUIPMENT STORED IN VANS

VAN #3

AVILA BEACH

1300' 43" Expandi boom
492' 30" Expandi boom

Sorbents

Conwed

Booms 5 bx/40' per
Sweeps 3 boxes

3M Company

Booms 5 bx/40' per
Sheets 5 bx/100 per
Sweeps 5 bx/100' per

Dow

Bags 1 bx/100 per
Blankets 20 bx/1 per
Oil Snare 1 bx/100 per

51T Acme skimmer w/1200 gallon bag
Skimmer hose
25' 3" discharge hose 2
3" valve 1
30' 1/2" poly buoy line w/buoy 1
100' 1/2" nylon, 100' 3/4" tow line 1
1000' 1/4" manila 1
Hose floats 5
Life preservers 5
Pitchforks 2
Rakes 1
Tools Misc.
55 gallon drums 2
Anchors 22# 4
Anchor line 200' 1/2" nylon 4
Crown line 200' 1/2" poly w/buoy 4
Chemical lights -5
15' aluminum boat w/9.8 hp outboard motor - 1

This equipment could be transported to an affected area in Ventura or Santa Barbara counties in 4 hours.

CSI EQUIPMENT STORED IN VANS

VAN #4

VENTURA HARBOR

1500' 43" Expandi boom
738' 30" Expandi boom

Sorbents

Conwed

Boom 10 bx/24' per
Sweeps 5 boxes
Blankets 1 roll
Rugs 1 roll

3M Company

Boom 10 bx/40' per
Sheets 10 bx/100' per
Sweeps 2 bx/100' per

Dow

Blankets 20 bx/1 per
Bags 1 bx/100 per
Oil Snare-1 bx/30 per

51T Acme skimmer w/1200 gallon bag
Skimmer hose 2
25' 3" hose 1
3" valve 2
3' 1/2" poly buoy line w/buoy 1
100' 1/2" nylon, 100' 3/4" tow line 1 ea
1000' 1/4" manila line 1 bx
Hose floats 5
Life preservers 4
Pitchforks 2
Rakes 1
Tools Misc.
55 gallon drums 2
Anchors 4/22# 4
Anchor line 200' 1/2" nylon 4
Crown line 200' 1/2" poly w/buoy 4
Chemical lights 10
15' aluminum boat 2/9.8 hp outboard motor - 1

This equipment could be transported to any affected area in 2 hours.

CSI EQUIPMENT STORED IN VANS

VAN #5

SANTA BARBARA

1500' 43" Expandi boom
800' 8" Kepuer boom

Sorbents

<u>Conwed</u>	
Sweeps	3 bx
Rugs	1 roll
Blankets	1 roll
<u>3M Company</u>	
Booms	10 bx/40' ea
Sheets	5 bx/100' ea
Sweeps	2 bx/100' ea
<u>Dow</u>	
Bag	1 bx/100 per
Blankets	20 bx/1 per
<u>Oil Snare</u>	1 bx/30 per

39T Acme skimmer w/1200 gallon bag	
Skimmer hose	2
25' 3" discharge hose	1
3" valve	2
30' 1/2" poly line w/buoy	1
100' 1/2" nylon, 100' 3/4" tow line	1
1000' 1/4" manila	1 bx
Hose floats	5
Life preservers	4
Pitchforks	2
Rakes	1
Tools	Misc.
55 gallon drums	2
Anchors 4/22#	4
Anchor line 200' 1/2" nylon	4
Crown line 200' 1/2" poly w/buoy	4
Mops	5
Chemical lights	10

This equipment could be mobilized in 2 hours.

CSI EQUIPMENT STORED IN VANS

VAN #6

POINT DUME

410' 30" Expandi boom

Sorbents

Conwed

Sweeps 3 boxes
Rugs 1 roll
Blankets 1 roll

3M Company

Booms 10 bx/40' ea
Sheets 5 bx/100' ea
Sweeps 2 bx/100' ea

Dow

Bag 1 bx/100 per
Blankets 20 bx/1 per
Oil Snare 1 bx/30 per

51T Acme skimmer w/1200 gallon bag
Skimmer hose 2
25' 3" discharge hose 1
3" valve 2
30' 1/2" poly line w/buoy 1
100' 1/2", 100' 3/4" tow line 1
1000' 1/4" manila 1 bx
Hose floats 5
Life preservers 4
Pitchforks 2
Rakes 1
Tools Misc.
55 gallon drums 2
Anchor 4/22# 4
Anchor lines 200' 1/2" poly w/buoy 4
Crown lines 300' 1/2" poly w/buoy 4
Chemical lights 5

This equipment could be transported to any affected area in Ventura County in 2 hours.

SELF-PROPELLED OIL RECOVERY EQUIPMENT

EQUIPMENT	LOCATION	MATERIALS STORED ON EQUIPMENT	
Tide-Mar VII Barge	Ventura Marina	Hose: Sorbents:	11 ea. 4" x 25' suc. <u>Conwed</u> Boom - 3 boxes Sweeps - 3 boxes Rugs - 1 roll Blankets - 1 roll <u>3M Company</u> Boom <u>Dow</u> Imbiber Blankets - 3 boxes
CSI Skimmer	Santa Barbara Harbor	Boom:	<u>Kepner</u> 480' x 30"
		Storage Bag: Hose:	5000 gallon 4 ea. 4" x 25' suc. 3 ea. 2" x 25' suc.

The above equipment is maintained for immediate use. Mobilization would be affected by support vessel availability. Mobilization would require approximately 6 hours. Full deployment could be achieved in 2 hours.

LOCAL UNCOMMITTED EQUIPMENT

CSI - MEMBER OWNED

The following is an inventory of known anti-pollution equipment and material owned by member companies of CSI. It is felt that any or all of this equipment could be fully deployed within 8 hours of notification.

COMPANY	QUANTITY	ITEM	LOCATION	
Atlantic-Richfield	300'	Kepner Sea Curtain boom	Platform Holly	
	500'	Whittaker 30" Expandi-Boom	Platform Holly	
	1	Acme 51T skimmer unit	Platform Holly	
	5 bales	3M Type 156 sorbent	Platform Holly	
	2 drums	Shell oil herder	Platform Holly	
	600'	Conwed sorbent boom	Rincon Island	
	4 bales	3M Type 156 sorbent	Rincon Island	
	3 drums	Shell oil herder	Rincon Island	
	Chevron U.S.A.	360'	Conwed sorbent boom	Platform Hope
		2 boxes	Conwed pre-assembled sweeps	Platform Hope
2 boxes		Conwed sweeps	Platform Hope	
360'		Conwed sorbent boom	Platform Heidi	
2 boxes		Conwed pre-assembled sweeps	Platform Heidi	
2 boxes		Conwed sweeps	Platform Heidi	
1		Unitized skimmer system w/storage	Platform Heidi	
300'		8" Kepner Sea Curtain boom	Platform Heidi	
360'		Conwed sorbent boom	Platform Hazel	
2 boxes		Conwed pre-assembled sweeps	Platform Hazel	
360'		Conwed sorbent boom	Platform Hilda	
2 boxes		Conwed pre-assembled sweeps	Platform Hilda	
2 boxes		Conwed sweeps	Platform Hilda	
1		Unitized skimmer system w/storage	Platform Hilda	
5 boxes		Conwed sorbent booms (3-8' pieces/box)	Morro Bay	
10-35# bags		Conwed sorbent fibers	Morro Bay	
10 pkgs.		3M oil sorbent sheets - Type 151 (200 sheets/pkg, 3/16" thick)	Morro Bay	
10 pkgs.		3M oil sorbent sheets - Type 156 (100 sheets/pkg, 3/8" thick)	Morro Bay	
20		3M oil sorbent booms - Type 270 (10' each)	Morro Bay	
5		3M oil sorbent sweeps - Type 126 (100' each)	Morro Bay	
3-1/2		3M oil sorbent rolls - Type 100 (150' each)	Morro Bay	
3		3M oil sorbent pillow (approx. 2' x 1-1/2' each)	Morro Bay	
10		Boxes 45 gallon plastic trash bags (100 bags each)	Morro Bay	
2 bales		Burlap sacks (approx. 500 sks ea)	Morro Bay	
200 bales		Excelsior	Morro Bay	

CSI MEMBER OWNED LOCAL UNCOMMITTED EQUIPMENT (cont'd)

COMPANY	QUANTITY	ITEM	LOCATION
Chevron U. S. A.	1	Acme sk 51T-A1.7 tunnel skimmer gasoline engine driven	Morro Bay
	1	3000' Kepner sea boom	Morro Bay
	3	Pumps (1 Jaeger, 1 Wilden, 1 Rex)	Morro Bay
	1	Air compressor	Morro Bay
	10	Portable radios	Morro Bay
	1	Emergency light plant (lights, generator)	Morro Bay
	Misc.	Suction hoses	Morro Bay
	Misc.	Shovels, rakes, asphalt lutes (approx. 100 each)	Morro Bay
Exxon Co., U. S. A.	1000'	Whittaker 43" expandi boom	Platform Hondo
	1	Komara Mini-Skimmer system	Platform Hondo
	1	Dunlop 1000 gallon dracone	Platform Hondo
	20	Cyalume chemical lights	Platform Hondo
	5 bales	3M type 156 sorbent	Platform Hondo
	2 drums	Corexit 9527 dispersant	Platform Hondo
	2 drums	OC-5 collectant	Platform Hondo
	1	Hudson sprayer	Platform Hondo
	1	21' Boston whaler w/2-70 hp outboards	Platform Hondo
Getty Oil - Union Oil	1	25' boom launch w/225 hp engine and 500' of 8" x 12" boom	Santa Barbara
	1	25' boom launch w/225 hp engine and 500' of 10" x 16" boom	Santa Barbara
Mobil Oil	29 boxes	Conwed sorbent pads (110 pads/bx)	Ferguson Lease
	1	21' Boston whaler (135 hp and trailer)	Ferguson Pier
	608'	3M type 270 sorbent boom in container	Ferguson Pier
	30 bales	Excelsior	#2 Tank Farm - Padre Lease
	4 bales	Excelsior	Compressor House - Padre Lease
Phillips Petroleum	6	Conwed sorbent blankets (3' x 200')	Tajiguas site
	4 boxes	Conwed sorbent sweeps (120 pads/box)	Tajiguas site
	4 boxes	Conwed sorbent sweeps (120 pads/box)	Platform Hogan
	3	Conwed sorbent blankets (3' x 50')	Platform Hogan
	160'	3M type 270 sorbent boom	Platform Hogan
	3	3M type 120 sorbent sweeps (22' x 100')	Platform Hogan
	500'	Slickbar 6" x 10" boom	Platform Hogan

CSI MEMBER OWNED LOCAL UNCOMMITTED EQUIPMENT (cont'd)

COMPANY	QUANTITY	ITEM	LOCATION
Phillips	1	MIMCO saucer skimmer w/motor	Platform Hogan
Petroleum	5 drums	Corexit 7664 dispersant	Platform Hogan
	2 boxes	Conwed sorbent sweeps (120 pads/box)	Platform Houchin
	4	Conwed sorbent blankets (3' x 150')	Platform Houchin
	160'	3M type 270 sorbent boom	Platform Houchin
	4	3M type 120 sorbent sweep (22" x 100')	Platform Houchin
	500'	Slickbar 6" x 10" boom	Platform Houchin
	1	MIMCO saucer skimmer w/motor	Platform Houchin
	1	175 cfm compressor for use with booms on platforms Hogan/Houchin	Platform Houchin
	5 drums	Corexit 7664 dispersant	Platform Houchin
	6	Conwed sorbent blankets (3' x 50')	La Conchita site
	4 boxes	Conwed sorbent sweeps (120 pads/bx)	La Conchita site
	10 bbl	Corexit 7664 dispersant	CSI yard-Carpinteria
Sun Oil	1200'	Slickbar 6" x 10" boom	Platform Hillhouse*
	1	36" Acme skimmer w/motor	Platform Hillhouse*
	1	Holman air compressor	Platform Hillhouse*
	10 drums	Corexit 7664 dispersant	Platform Hillhouse*
	200'	Conwed sorbent boom	Platform Hillhouse*
	120	Conwed Petro-mesh sorbent pillows	Platform Hillhouse*
*After completion, Platform Henry will be outfitted similarly.			
Texaco	2	1200 gallon floating oil containers	South Mountain Warehouse
	1722'	Whittaker 30" expandi boom w/ towing line and adapters	South Mountain Warehouse

LOCAL AVAILABLE UNCOMMITTED
EQUIPMENT & MANPOWER

The following is a list of local contractors specializing in oil-field support activities, such as field construction, trucking and material handling. It is felt that the companies listed represent only a portion of services available in Ventura County and could be fully mobilized in 8 hours.

AVAILABLE EQUIPMENT INVENTORIES

VENTURA AREA

American Welding Company
1070 North Ventura Aven
Ventura, California 93001
(805) 643-4275

Roustabout Crews

Barnett Trucking, Inc.
136 Telegraph Road
Post Office Box 416
Fillmore, California 93015
(805) 524-2377

4 - 100-Barrel Vacuum Trucks
5 - 60-Barrel Vacuum Trucks
2 - A-frames
1 - Bobtail
7 - Semi's
1 - Forklift
2 - Pickups
2 - Lowbeds

Bruce's Transport Service
Post Office Box 1457
Ventura, California 93001
(805) 648-5344

3 - 3/4 Ton Trucks
1 - 1 Ton Truck
2 - 5 Ton Trucks
2 - 10 Ton Trucks
5 - Truck-Tractors
10 - 40 Foot Trailers

Ecology Control (Formerly J & G)
2567 No. Ventura Avenue
Ventura, California 93001
(805) 648-5123

9 - 100-Barrel Vacuum Trucks
5 - 60-Barrel Vacuum Trucks

Petroleum Construction, Inc.
1350 East Santa Paula Street
Post Office Box 592
Santa Paula, California 93060
(805) 525-2144

See Attached Schedule 5/23/77

Trico Superior, Inc.
Post Office Box 4787
1804 Lirio
Ventura, California 93003
(805) 647-4166

Roustabout Crews
3 - A-Frames
2 - Forklifts
1 - Skiploader

Van Construction Company
1585 South Lirio Street
Ventura, California 93003
(805) 647-1103 or 647-5757

Roustabout Crews
10 - A-Frames
D6 Dozer w/side boom
Lowbed
1 - 1000-Gallon Water Truck
Air Compressors
Rubber-tired Loader
1 - Yard Backhoe

Offshore Crane, Inc.
335 Ponoma Street
Port Hueneme, California 93041
(805) 488-4475

10 - Truck Tractors
33 - Flatbed Trailers
9 - Cranes (various capacities)
2 - Forklifts

AVAILABLE EQUIPMENT INVENTORIES

VENTURA AREA

Reed Land Clearing, Inc.
1676 North Ventura Avenuc
Ventura, California 93001
(805) 648-3075

Cat 922 1-1/2 Cu Yd Skiploader
Cat 944 1-1/2 Cu Yd Skiploader
Cat 950 3.0 Cu Yd Skiploader
Cat 966A 3-1/2 Cu Yd Skiploader
Cat 966B 3-1/2 Cu Yd Skiploader
Cat 977 Skiploaders
Cat 977 Skiploader w/rock bucket
Cat 12F Grader
Backhoes - Rubber-tires 12", 18", 24", 30"
D-6 "C" Dozer
D-6 with Slopeboard
D-7 Dozer w/rippers
D-7 Dozer w/root Knife
D-8 Dizer 15A w/hyster winch & rock rake
D-8 Dozer 46A w/rippers
6' Essick Vibrating Sheepsfoot
6' Essick Vibrating Smooth Rooler
9' Brush Disc
4 x 4 Double-drum Pull Sheepsfoot
10-12 Cu.Yd. Dump Trucks
Semi Dump Truck, high volume demo/
54 Cu Yd
Semi Rock Trailer
K.W. Heavy Duty Tractor and Lowbed

DESCRIPTION OF EQUIPMENT

DOZERS

JD 450 Crawler w/Sideboom

GENERATORS

Portable Single-Phase Generator
Miller, 10KW Single Phase

POWER SAWS, DRILLS & GRINDERS

Skill Saw
Power Drills
Power Grinder
Chain Saw
Roto Hammer

PIPELINE EQUIPMENT

Pipe Benders
Pipe Locator
Pipe Wrapper
Pipe Line-up Clamps
Power Threaders
Victaulic Groovers 2" to 2-1/2"
Victaulic Groovers 3" to 4"
Reed Pipe Cutters 6" to 8"
Reed Pipe Cutters 9" to 12"
Reed Pipe Cutters 14" to 18"
Hot Tap Machine 1" to 2"
Hot Tap Machine 3" to 6"
Crossing Plates
Holiday Detector
Pipe Beveling Machine, 1-1/2" to 4"
Pipe Beveling Machine, 4" to 8"
Pipe Beveling Machine, 8" to 12"
Arrow Hydra Hammer

PUMPS

2" Diaphragm - Hand Pump
3" Centrifugal
3" Diaphragm
Homelite Pump
Test Pump
3" Discharge Hose (50' each)
1-1/2" Discharge Hose (50' each)
1-1/2" Fire Hose (50' each)
3" Suction Hose
High Pressure Trailer-mounted Test Pump
Submersible Electric
Butane Pot w/torch

SAND BLASTER

Sand Blast Pot w/hoses + Sand
w/Air Compressor & 50' hose

SKIP LOADERS

JD-300 Skip
JD-544 Skip

STEAM CLEANER

Clayton - Trailer-mounted
plus Cleaning Compounds

TRAILERS

2-Wheel Tool Trailers
4-Wheel Equipment Trailers

TRUCKS

Pickups
"A" Frame Trucks
Flat Bed
Crew Cabs
Crew Cabs - 4-Wheel Drive
Truck - 6-Wheel Drive
Dump Truck (5 yards)
5-Ton Bucyrus Crane (3-hr. Min.)
w/Clam Breaking Ball or Cement Bucket

MISCELLANEOUS EQUIPMENT

Acetylene Welding Equipment
Portable Lights
Portable Paint Rig
Special Small Tools
Tank Flange Cutters
Tar Pot
Transit
Trench Jacks
Welding
Step Jacks
Hydro Jacks - 1-12 Tons
Hydro Jacks - 20-50 Tons
Asphalt Roller - 1-1/2 to 2 Tons
High Pressure Sprayer

DESCRIPTION OF EQUIPMENT

BACKHOES

John Deere 350 Crawler w/dozer
Sideboom & Backhoe

John Deere 400 (rubber tires)
Backhoe & Loader

John Deere 450 Crawler w/dozer
Sideboom & Backhoe

John Deere 500 (rubber tires)
Backhoe & Loader w/Concrete Breaker
Including 210 cu. ft. Air Compressor

COMPRESSORS & ACCESSORIES

125-cu ft. w/one Air Tool & 100' hose

210-cu ft. w/out tools

365-cu ft. w/out tools

Air Tools, each

Air Hose, 50' each

Air Tank Fan

Air Impact Wrench

Chisels, Clay Spade, Gads, Paving Cutter,

Points & Drill Steel

Air Breathing Equipment w/Air Compressor

and 100' Air Hose

Gas Detector

CONCRETE EQUIPMENT

Concrete Mixer (1/2 Sack)

Concrete Vibrator

Concrete Hand Tools

Cement Saw

Plus \$1.00/1,000" Blade Wear

LOCALLY AVAILABLE UNCOMMITTED
MARINE & DIVING CONTRACTORS

Several marine and diving contractors operate facilities in the Channel Islands area. The following is a list of those companies. The local marine contractors have at their disposal a number of vessels suitable for offshore use, most of which are based out of Port Hueneme or Santa Barbara. It is felt that these vessels would be available within 6 hours of notification.

The diving companies listed have extensive local inventories of diving equipment, including materials for repairing all pipelines operated in the Santa Barbara Channel. These companies can be mobilized in 4 hours, and could be on location in the Ventura area within 8 hours.

BOATS

Crowley Maritime Corporation	Port Hueneme	805/488-3518
General Marine Transport	Santa Barbara	805/963-3808
Tidewater Marine Pacific, Inc.	Santa Barbara	805/963-1774

DIVERS

Ocean Systems, Inc.		805/965-3321
Associated Divers, Inc.		805/967-8118
Taylor Diving & Salvage		805/644-9939
Martec, International		805/964-9894

LOCALLY UNCOMMITTED AIRCRAFT

Following is a list of available aircraft in the Ventura County area. It is felt that the majority of aircraft would be available within 8 hours of notification.

HELICOPTERS

<u>NO. AVAIL.</u>	<u>TYPE OF CRAFT</u>	<u>WHERE TO OBTAIN</u>
3	Sikorsky S-55 6 passenger 1200# payload	Rotor Aids Offshore, Inc. 1500 Spinnaker Drive P. O. Box 1238 Ventura, CA 93001
2	Alouette II 4 passenger 700-800# payload	Ventura Marina - 805/642-8584 or 805/642-8347 Santa Barbara Airport - 805/964-1825
1	Bell 205 13 passenger 3000# payload	
3	Bell G5 2 passenger 600# payload	Coastal Chemical Company Ventura County Airport 805/483-3234 or 805/487-4961
1	Lear Jet Model 23 6 pass. 2 pilots	Oceanaire Helicopter Services, Inc. 714/534-9110 After hours: [REDACTED]
1	Turbo Navajo Twin Engine 6 passenger	
3	Bell Jet 206B 4 passenger	
2	H-1100 4 pass. 900# payload	Condor Helicopters & Aviation, Inc. Ventura County Airport [REDACTED]
2	Bell Jet Ranger 206B 4 pass. 1400# payload	
1	Sikorsky S-50 12 pass. 400# payload	
1	Boeing BO 105 Twin engine turbo 2500# payload	
1	Bell G-5 (equipped for spraying liquid chemicals, 100 gal cap.) 2 pass - 600# payload	
1	Bell G-3-B-1 (equipped for spraying liquid chemicals, 100 gal cap.) 2 pass - 600# payload	

LOCALLY UNCOMMITTED AIRCRAFT (cont'd)

FIXED WING

NO. AVAIL.	TYPE OF CRAFT	WHERE TO OBTAIN
1	Grumman Ag-Cat 2000# payload 220 gallon tank	Condor Helicopter & Aviation, Inc. Ventura County Airport [REDACTED]
3	Grumman Ag-Cat 2000# payload 300 gallon tanks	Coastal Chemical Company, Aviation Div. Ventura County Airport [REDACTED]

REGIONALLY COMMITTED AVAILABLE EQUIPMENT

The following is a list of regionally committed equipment owned by Union Oil Company. Additionally, an extensive inventory of anti-pollution and cleanup equipment is available through the Southern California Petroleum Contingency Organization, 213/833-4426. It is an organization similar to Clean Seas, and this equipment would be available within 24 hours of notification.

COMPANY	QUANTITY	ITEM	LOCATION
Union Oil	2	Aluminum workboats (14'), one with 7 hp outboard	Avila Wharf
	10	Assorted hand tools	Avila Wharf
	4	Handy-talkies (var. frequencies)	Avila Wharf
	4	Walkie-talkies (var. channels)	Avila Wharf
	1	Base station (var. channels)	Avila Wharf
	1500'	Kepner Sea Curtain (16" x 24")	Avila Wharf
	600'	Slickbar boom (6-1/2" x 6")	Avila Wharf
	6 bxs	Conwed sorbent pads	Avila Wharf
	9 bxs	Poly-pro sorbent	Avila Wharf
	10 bxs	Conwed Petro-mesh sorbent pillows	Avila Wharf
	1	100 gallon Kepner Seovac separator	Avila Wharf
	2	Homelite 2" trash pumps	Avila Wharf
	1	Dayton portable generator (1.5 kw)	Avila Wharf
	1	Fiberglass skiff 14' w/15 hp outboard	Avila wharf

This equipment could be transported to any affected area in Santa Barbara or Ventura counties within 5 hours.

REGIONALLY UNCOMMITTED AVAILABLE INVENTORIES

The following is a listing of selected contractors providing oil field support services in the Wilmington and Santa Maria areas. It is felt that this list reflects only a portion of available contractors, and could be fully mobilized and on location within 24 hours.

SANTA MARTA AREA

Jerry Nunn, Contractor
848 W. Betteravia Road
Santa Maria, California 93454
(805) 925-6711 Night: 925-7726

1 - D-6 Cat
1 - Motor Grader
2 - Backhoes
10 - Pickups
1 - Skiploader
8 - Cranes
10 - 2-Ton Trucks w/A-Frames
4 - Large Hi-bed Trucks
Men and Tools

Tony Sanchez
Post Office Box 204
Santa Maria, California 93454
(805) 922-5545

4 - D-8 Cats
3 - D-6 Cats
1 - Motor Grader

Rich-Sand
Post Office Box 2403
Orcutt, California 93454
(805)937-6681

Vacuum Trucks:
7 - 70-barrel
2 - 130-barrel
1 - 110-barrel

Engel and Gray Trucking
Post Office Box B
745 W. Betteravia Rd.
Santa Maria, California 93454
(805) 925-2771

1 - Skiploader
2 - Backhoes
4 - Cranes
4 - 2-Ton Trucks w/A-Frames
4 - Lowbed Trucks
4 - Semi's w/Tractors

Trico Superior
2615 Skyway Drive
Santa Maria, California 93454
(805) 922-5874 or 925-1018

1 - Backhoe
8 - 2-Ton Trucks w/A-Frames
Men, Tools, Pickups

Van Construction
495 Betteravia Road
Santa Maria, California 93454
(805) 922-5397

1 - Backhoe and Skiploader
Men, Pickups and Tools
2 - 2-Ton Trucks

AVAILABLE EQUIPMENT INVENTORIES

SEAL BEACH AREA

O'Meara & Rogers
1250 E. 23rd Street
Post Office Box 1728
Long Beach, California 90801
(213) 426-9451

Bulldozers
Backhoes
Trucks
Men and Equipment
24-Hour Call

Trico Superior
6155 South Eastern Avenue
Los Angeles, California 90022
(213) 726-0212

Trucks
Men and Equipment
24-Hour Call

Steverson Vacuum Truck Service
18062 Gothard Street
Huntington Beach, California 92648
(714) 847-1072

9 - 100-Barrel Vacuum Trucks
and Lo-bed Trucks

Routh Transportation
800 West 15th Street
Long Beach, California 90813
(213) 435-4823

Vacuum Trucks
24-Hour Service

IT Services
217 N. Lagoon Avenue
Wilmington, California 90744
(213) 830-1720

Vacuum Trucks
Trucks
Men & Equipment
Marine Pollution Control Equipment
24-Hour Service

Speed's Oil Tool Service
110 Betteravia Road
Santa Maria, California 93454
(805) 925-1369 or 925-4510

Vacuum trucks:
4 - 70-barrel
2 - 110-barrel
1 - 55-barrel

BOATS

Pacific Towboat & Salvage Co.	213/432-6487
Jones Tug & Barge Co.	213/432-6419
San Pedro Tugboat Co.	213/832-1158
Wilmington Transportation Co.	213/832-4292

DIVERS

Ocean Systems	213/830-7868
International Divers	408/248-3262

SPCC PLANNING FOR SENSITIVE HABITAT AREAS

The first map (Figure I) shows the southern portion of the CSI area of interest and divides the shoreline area into individual segments, identifying areas of special biological significance.

Figure I points out different designations of offshore and shoreline areas in the Santa Barbara Channel Region. Of five main types of important and somewhat biologically unique . . . recently described by the Bureau of Land Management (BLM), three types occur in the Channel Region:

- (1) Area of Special Biological Significance (ASBS);
- (2) Unique Biological Area (UBA); and
- (3) Biologically Sensitive Area (BSA)

An ASBS is a specific BLM designation further identified by the California State Water Resources Control Board as an area requiring special protection of marine life through prohibition of waste discharges. Within the Channel Region, two ASBS occur: (a) Mugu Lagoon to Latigo Point; and (b) around San Miguel, Santa Rosa, Santa Cruz and Anacapa Islands.

A UBA is not specifically defined, but the entire shoreline of San Miguel Island (the only UBA in the Channel Region) is designated as a UBA because of the island's breeding and foraging significance to pinned (marine mammal) and seabird populations.

A BSA is likewise not specifically defined, but a number of mainland shoreline locations have been designated BSA based on recent studies by Dr. J. L. Siva of Atlantic Richfield Company. Eight BSA locations have been identified because of unique biological or ecological significance or because of vulnerability to oil pollution: (a) Point Conception; (b) Burmah Beach; (c) Goleta Slough; (d) Goleta Rocks; (e) Carpinteria Slough (El Estero); (f) Chevron Pier; (g) Ventura River Mouth; and (h) Santa Clara River Mouth.

Additionally, Figure I depicts each estuary, anadromous fish stream and other unusual mainland features or areas that could require protection in the event of a pollution incident.

All of the above are further described, one by one, in the following sections. Each sensitive area is fully identified as corresponding to a specific response action in the Clean Seas, Inc., manual (Response Guide 3). Addressed are types of shorelines, descriptions of the nature of the biological resources, determination of response actions and implementation.

Depending on the scale of significance used, there are a number of other areas (for example, scattered rocky shore areas along the entire coastline, kelp beds or coastal strand dune vegetation systems) that could be considered sensitive simply because of proximity to a spill. In the event of such an incident, any rocky shore area or kelp bed could be adversely affected directly by oil, while a dune system could be indirectly affected through the use of nearby areas as staging points for cleanup equipment. These numerous scattered areas have not been specifically identified in the following sections, but would be taken into consideration in the event of a spill incident.

SENSITIVE HABITAT A
of the
SANTA BARBARA CHANNEL

Legend:

- E ESTUARY
- E-1 SANTA YNEZ RIVER
- E-2 JALAMA BEACH
- E-3 GOLETA SLOUGH & UNIVERSITY LAGOON
- E-4 CARPINTERIA SLOUGH (EL ESTERO)
- E-5 VENTURA RIVER
- E-6 SANTA CLARA RIVER
- E-7 MUGU LAGOON
- GOLETA ROCKS & ANACAPA I. also contain Pinniped Rookeries and/or Hauling Areas & Bird Nesting/Breeding Areas

- ▲ ANADROMOUS FISH STREAM
- ⋯ PINNIPED ROOKERIES AND/OR HAULING AREAS
- ▨ BIRD NESTING/BREEDING AREAS
- ▩ UNIQUE BIOLOGICAL AREA (UBA)
- ▧ BIOLOGICALLY SENSITIVE AREAS (BSA)
- ▦ AREAS OF SPECIAL BIOLOGICAL SIGNIFICANCE (ASBS)

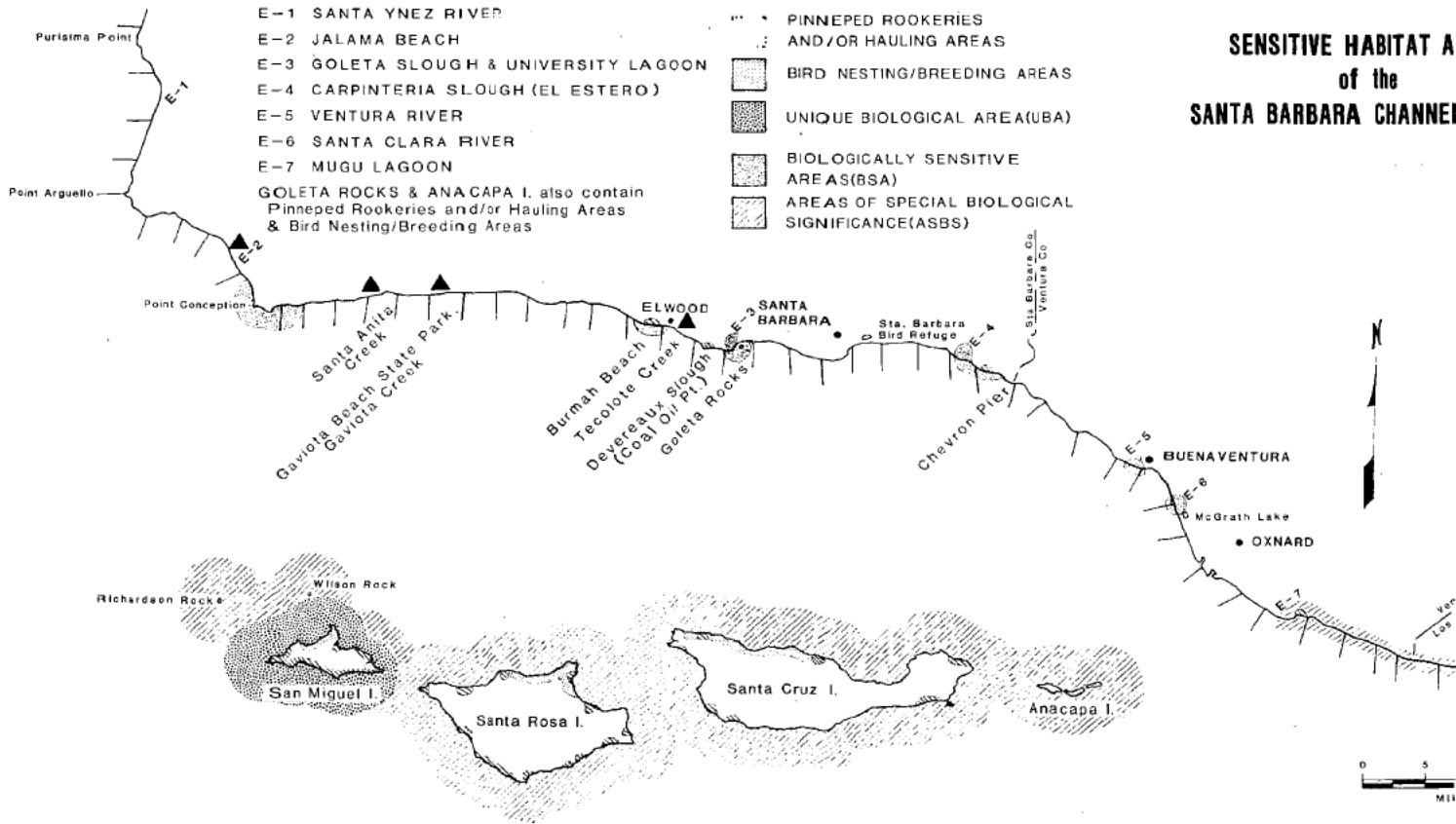

SUMMARY OF SENSITIVE HABITAT AREAS

SANTA YNEZ RIVER MOUTH AND ESTUARY - A highly productive estuarine system commonly used as feeding grounds by numerous shorebird populations. The river mouth is commonly barred by sand but opens up at certain times of the year dependent on river flood or storm surge conditions.

JALAMA CREEK AND BEACH - A small estuary provides entrance to an anadromous fish stream. The creek mouth is commonly closed to the ocean by a sand bar but opens up at certain times of the year.

POINT CONCEPTION - A BSA because of the undisturbed rich rocky intertidal communities and its importance as a biogeographical boundary between cold and warm temperate biotic provinces; a well-described natural oil seep area.

SANTA ANITA CREEK MOUTH - An anadromous fish stream opening to a sandy beach.

GAVIOTA CREEK MOUTH - An anadromous fish stream opening to a sandy beach at Gaviota Beach State Park.

BURMAN BEACH - A BSA; sandy beach used as a haul-out area and (possibly) occasionally used as a rookery area by pinnepeds.

TECOLOTE CREEK MOUTH - An anadromous fish stream opening to a sandy beach at Ellwood; near a well-documented natural oil seep area.

DEVEREAUX SLOUGH AND COAL OIL POINT - Certain specific locations used as haul-out areas by pinnepeds; the slough is a large productive estuarine system occasionally open to the ocean but usually enclosed by a sand bar; Coal Oil Point is a well documented natural oil seep area.

GOLETA SLOUGH, UNIVERSITY LAGOON, AND GOLETA ROCKS - Both estuaries are highly productive and are breeding or foraging areas for large bird populations; Goleta Slough is designated a BSA because of its large size and significance to bird populations; Goleta Rocks are designated a BSA because of their use as a pinneped haul-out area. Additionally, Goleta Slough is habitat for

at least two endangered species of birds. Goleta Slough is usually open to the ocean, but occasionally closed by a sand bar; University Lagoon is usually closed by a sand bar.

CARPINTERIA SLOUGH (EL ESTERO) - A BSA because the large, highly productive estuarine system serves as a breeding/foraging area for a number of bird populations, including at least two endangered species; this is the largest marsh complex in Santa Barbara County, opening to the ocean via a tidal channel at Sand Point.

CHEVRON (CASITAS) PIER AREA - A BSA due to its use as a haul-out area for pinnepeds.

VENTURA RIVER MOUTH AND ESTUARY - A BSA because of its highly productive estuarine system and use by bird populations; Ventura River mouth is seasonally barred by sand.

SANTA CLARA RIVER MOUTH AND ESTUARY - A BSA because of its large size, its high estuarine productivity and its use as a breeding/foraging area by numerous bird populations.

MUGU LAGOON - The largest and most important estuarine system in Ventura County, the far north end of the Mugu-Lagoon-to-Latigo-Point ASBS; contains a pinneped haul-out area near its southern center, and is used as a breeding/foraging area by numerous bird populations, including at least one endangered species; lagoon is maintained to be open to ocean.

MUGU LAGOON TO LATIGO POINT - A designated ASBS by BLM and the CSWRCB due primarily to its biologically rich intertidal and subtidal areas, but also because of the use of certain shoreline locations as breeding/foraging areas by numerous bird populations.

SAN MIGUEL ISLAND AND SURROUNDING WATERS - An ASBS out to the 3-mile limit (including certain offshore nearby rocks), and a UBA; this island contains a number of seabird breeding/foraging areas and the largest concentration

of pinneped rookeries and haul-out areas in the Channel Region; habitat for at least three rare/endangered species.

SANTA ROSA ISLAND AND WATERS - An ASBS out to the 3-mile limit because of the presence of a large number of seabird breeding/foraging areas and pinneped rookeries/haul-out areas; habitat for at least two rare/endangered species.

SANTA CRUZ ISLAND AND WATERS - An ASBS out to the 3-mile limit for reasons similar to those of the above two islands, although only certain parts of the island are heavily used by seabirds and/or pinnepeds; habitat for at least three rare/endangered species.

ANACAPA ISLAND AND WATERS - An ASBS out to the 3-mile limit because of use by seabirds and pinnepeds; habitat for at least one endangered species; part of Channel Islands National Monument.

LOMPOC LANDING

Shoreline Characteristics

General Description: Mostly rocky to the north giving way to low, flat, sandy beach with tidal ponds at Santa Ynez River.

Backshore: sand dunes or rocky cliffs to the north; sandy area to the south

Trafficability: good - firm sand

Cleanup Technique Code

(4 and 3 for park beach): temporary disposal site at beach parking area

Access

Principal Entry Points: Surf road and/or Lompoc Landing Road. Surf road unimproved and steep; requires RR crossing. Boat access at state park.

Boat Launching Facilities: ramp at county park

Inlets/Streams

Inlets: None

Streams: Santa Ynez River

Ownership and Control

Principal Property Owner(s):

Address: (1)	(2)
Vandenberg Air Force Base	County of Santa Barbara
Vandenberg, California	Ocean or Surf Beach Park
Phone: (805) 866-1611	(805) RE6-6693

Controlling Government Authority: Dept. of Defense & County Parks & Rec.

Waterfront Usage: Santa Ynez estuary is natural area.

Biological Data

Potential Threat to Wildlife: Numerous birds in Santa Ynez River wetlands

Special Biological Significance: CC designates Santa Ynez River wetlands and estuary and coastal area as part of a special marine environment.

Seasonal Factors

Entrance to Santa Ynez River commonly barred - inlet could open up at certain times of year.

Special Factors Affecting Spill Control

High currents will restrict booming seaward of RR trestle crossing estuary.

Comments

Monitor entrance to estuary for development of bar.

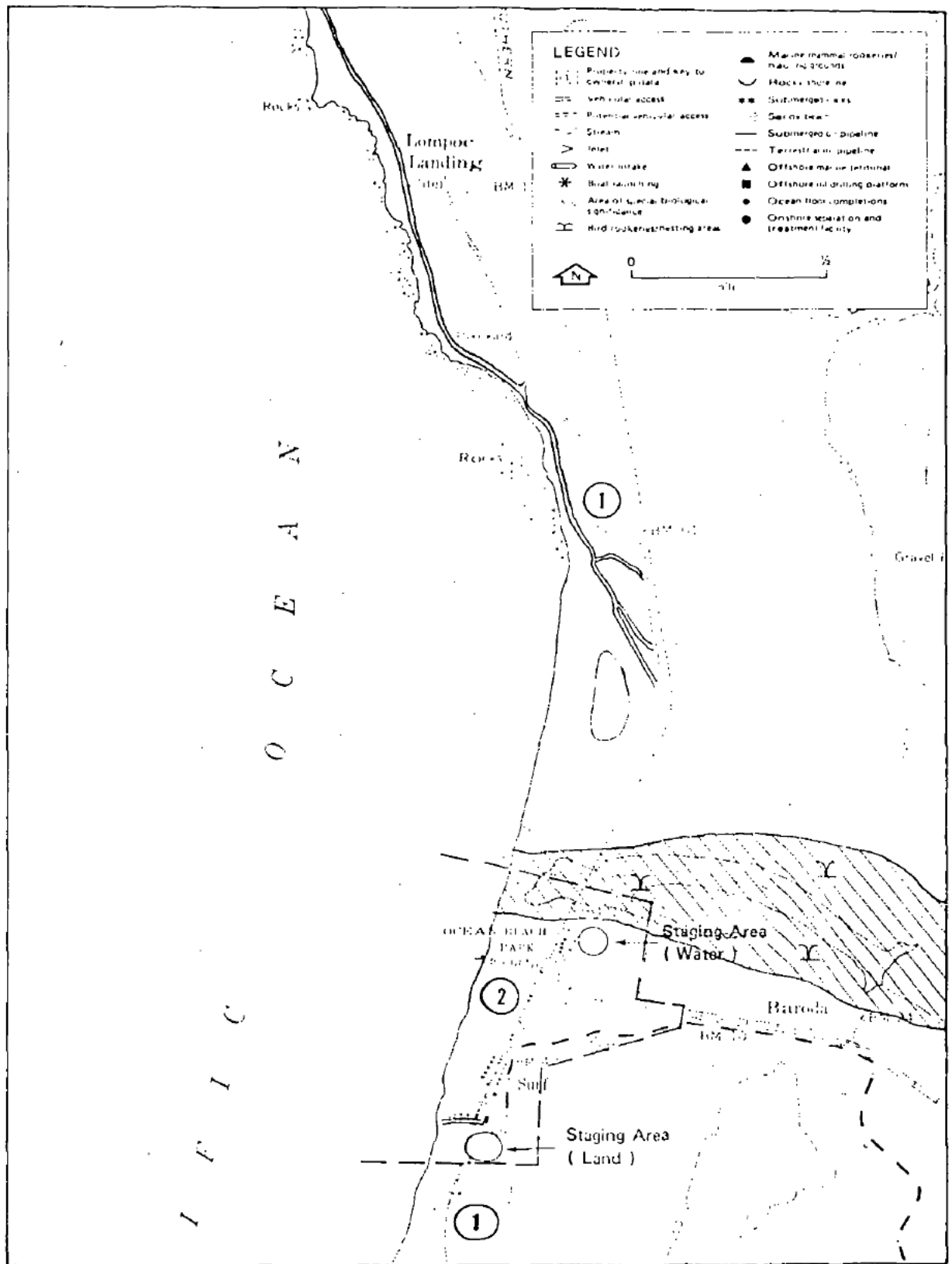

LOMPOC LANDING

JALAMA

Shoreline Characteristics

General Description: combination of rocky cliffs and small, narrow, steep, sandy beaches in north becoming broader and more sandy in the south

Backshore: steep bluffs

Trafficability: good on intertidal areas

Cleanup Technique Code: (4 - northern half, 3 - beach area);
temporary disposal site at beach parking area

Access

Principal Entry Points: Jalama Beach Road from the east of coast road from the south; stream crossing at Jalama Park may be impassable

Boat Launching Facilities: None Nearest: Gaviota

Inlets/Streams

Inlets: None

Streams: Jalama Creek (anadromous fish stream) and several other high gradient creeks

Ownership and Control

Principal Property Owner(s):

Address:

(1)	(2)	(3)
Vandenberg Air Force Base Vandenberg, California	County of Santa Barbara Park Dept Jalama Beach, California	Point Conception Co. 523 W. 5th Street Los Angeles, CA

Phone:

(805) 866-1611	(805) 736-0222	Unlisted
----------------	----------------	----------

Controlling Government Authority: Dept. of Defense & Parks and Recreation

Waterfront Usage: Natural and recreational

Biological Data

Potential Threat to Wildlife: anadromous fish

Special Biological Significance: Coastal area is designated as a special marine habitat.

Seasonal Factors

Jalama Creek inlet commonly barred; inlet could open at certain times of year. Sandy beaches may migrate on- and offshore seasonally.

Special Factors Affecting Spill Control

Jalama Creek inlet would have to be closed off if sand is eroded.

Comments

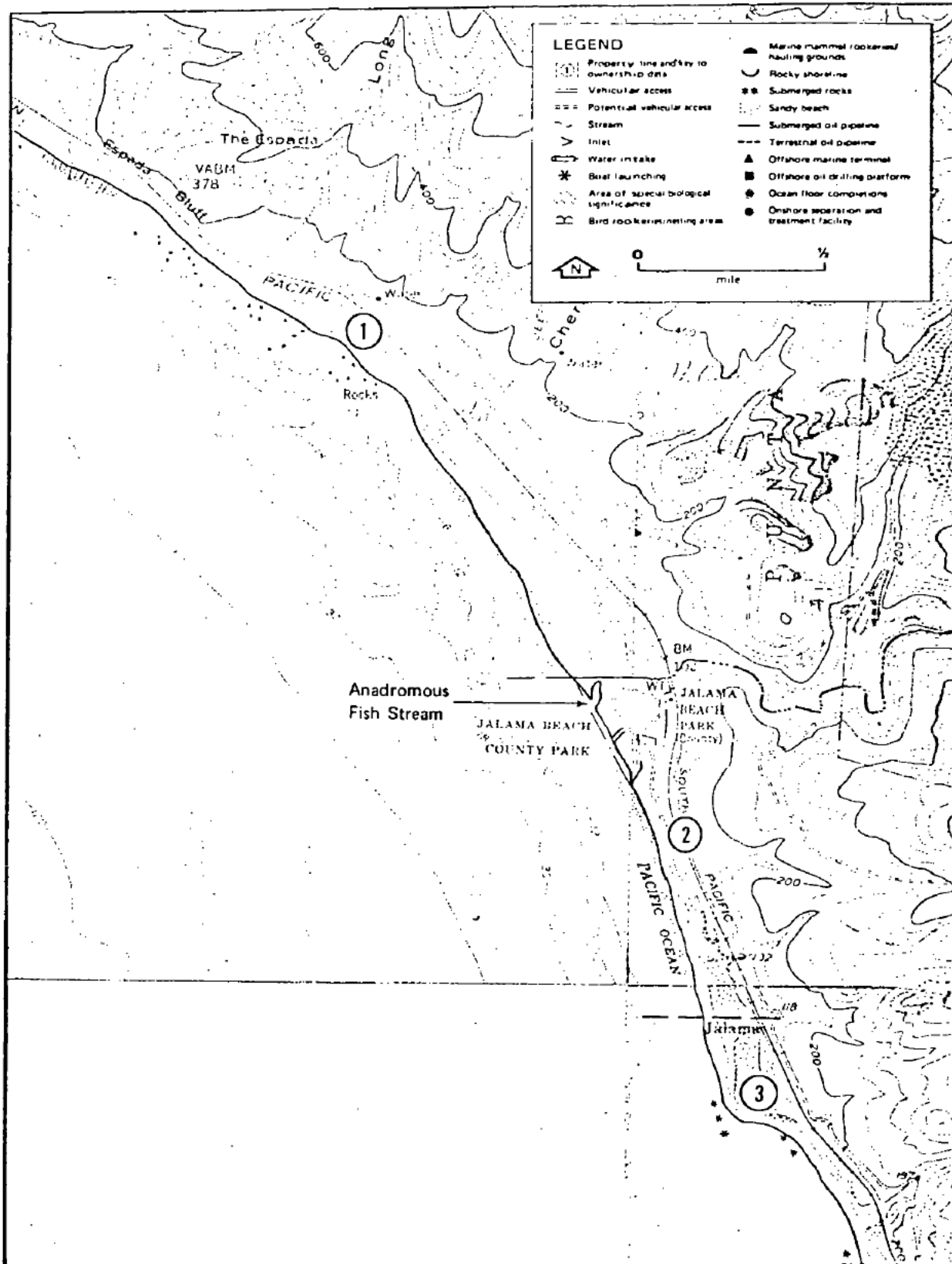

JALAMA

POINT CONCEPTION

Shoreline Characteristics

General Description: narrow, steep, sandy beaches with many submerged rocks toward the north

Backshore: steep bluffs, many cliffs

Trafficability: Unknown

Cleanup Technique Code: (4)

Access

Principal Entry Points: Jalama Beach Park Road to the north; Coast Guard station at Point Conception in the south

Boat Launching Facilities: None Nearest: Gaviota

Inlets/Streams

Inlets: None

Streams: several high gradient intermittent streams

Ownership and Control

Principal Property Owner(s):

Address: (1)	(2)	(3)
Point Conception Co. 523 W. 5th Street Los Angeles, CA	Standard Oil Co. 1 Dominion Road Santa Maria, CA	USCG Reservation Point Conception CA
Phone: not listed/unknown	(805) WE7-6333	(805) 962-7430

Controlling Government Authority:

Waterfront Usage: natural

Biological Data

Potential Threat to Wildlife:

Special Biological Significance: Kelp beds off the east coast of Point Conception provide good fishing for Santa Barbara's commercial fleet. Point Conception is the boundary between southern and central faunal zones; the boundary fauna is of particular interest and should be preserved (Siva, 1976).

Seasonal Factors

Special Factors Affecting Spill Control

Very high energy environment, self-cleaning should be rapid.

Comments

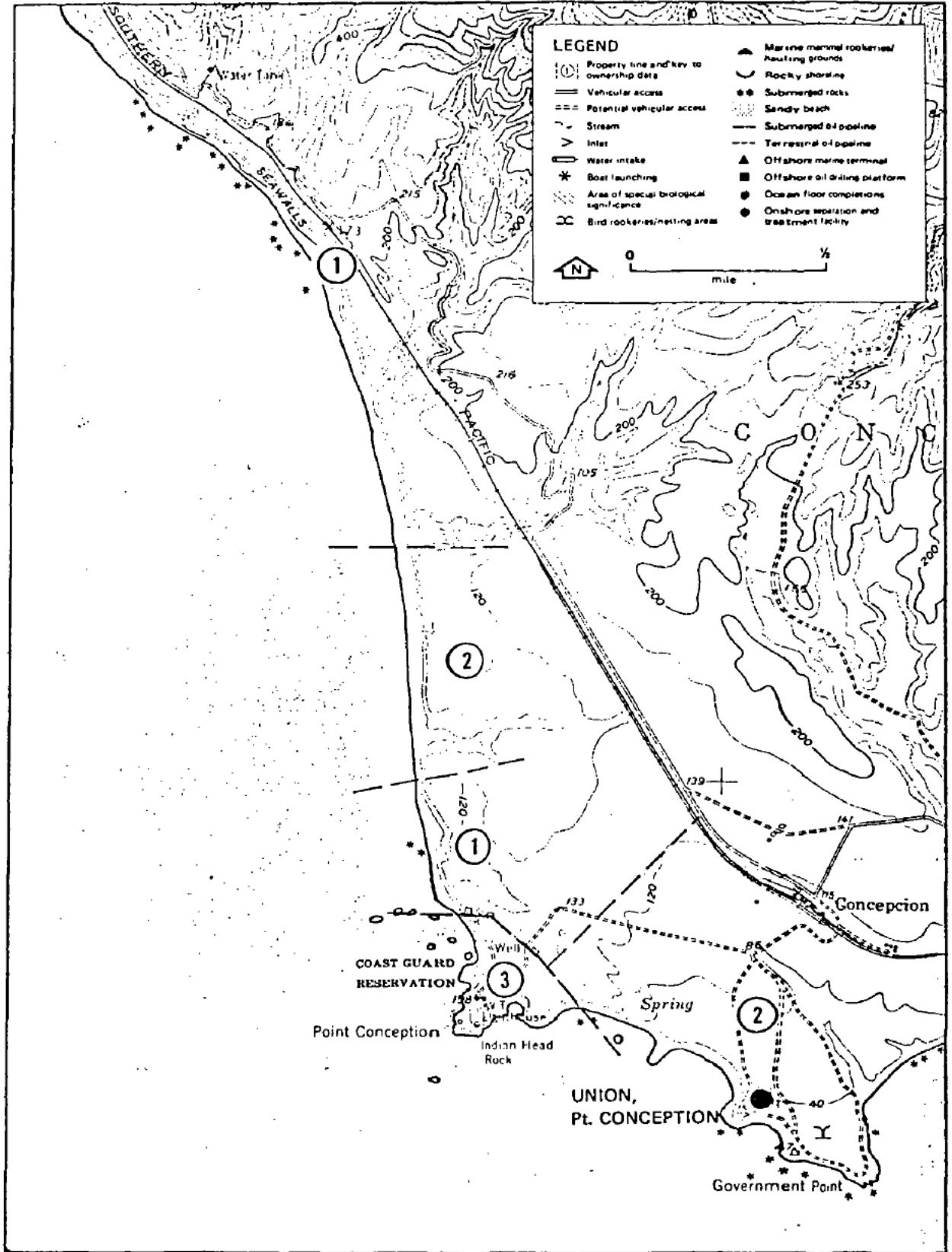

POINT CONCEPTION

DRAKE

Shoreline Characteristics

General Description: straight, narrow beaches with rocks and/or cliffs
on points; broad, flat beaches at some stream outfalls
Backshore: high bluffs or cliffs
Trafficability: unknown

Cleanup Technique Code: (4)

Access

Principal Entry Points: Hollister Ranch/coast road accessed from Gaviota
Beach State Park - roads will carry all types of vehicles
Boat Launching Facilities: None Nearest: Gaviota

Inlets/Streams

Inlets: None
Streams: Santa Anita Creek is identified by the CC as an anadromous fish
stream. Several other high gradient intermittent creeks.
Ownership and Control

Principal Property Owner(s):
Address: (1) Hollister, James
137 Anapamu St.
Santa Barbara, CA
Phone: (805) 963-6711
Controlling Government Authority: State of California
Waterfront Usage: limited private recreation and cattle grazing on bluffs

Biological Data

Potential Threat to Wildlife: tidal pool and kelp bed ecological systems
Special Biological Significance: South Coast Intertidal Preserve. CC notes
that the intertidal zone from Point Conception to Ellwood is particu-
larly valuable. It includes the state's most extensive kelp beds,
which support many fish; it should be protected from overuse so
that high productivity can be maintained.

Seasonal Factors

Sand beaches may migrate offshore in winter, exposing rock ledges.

Special Factors Affecting Spill Control

High energy environment - should self-clean rapidly.

Comments

Possible local burial of oil by shifting channels at major creek mouths

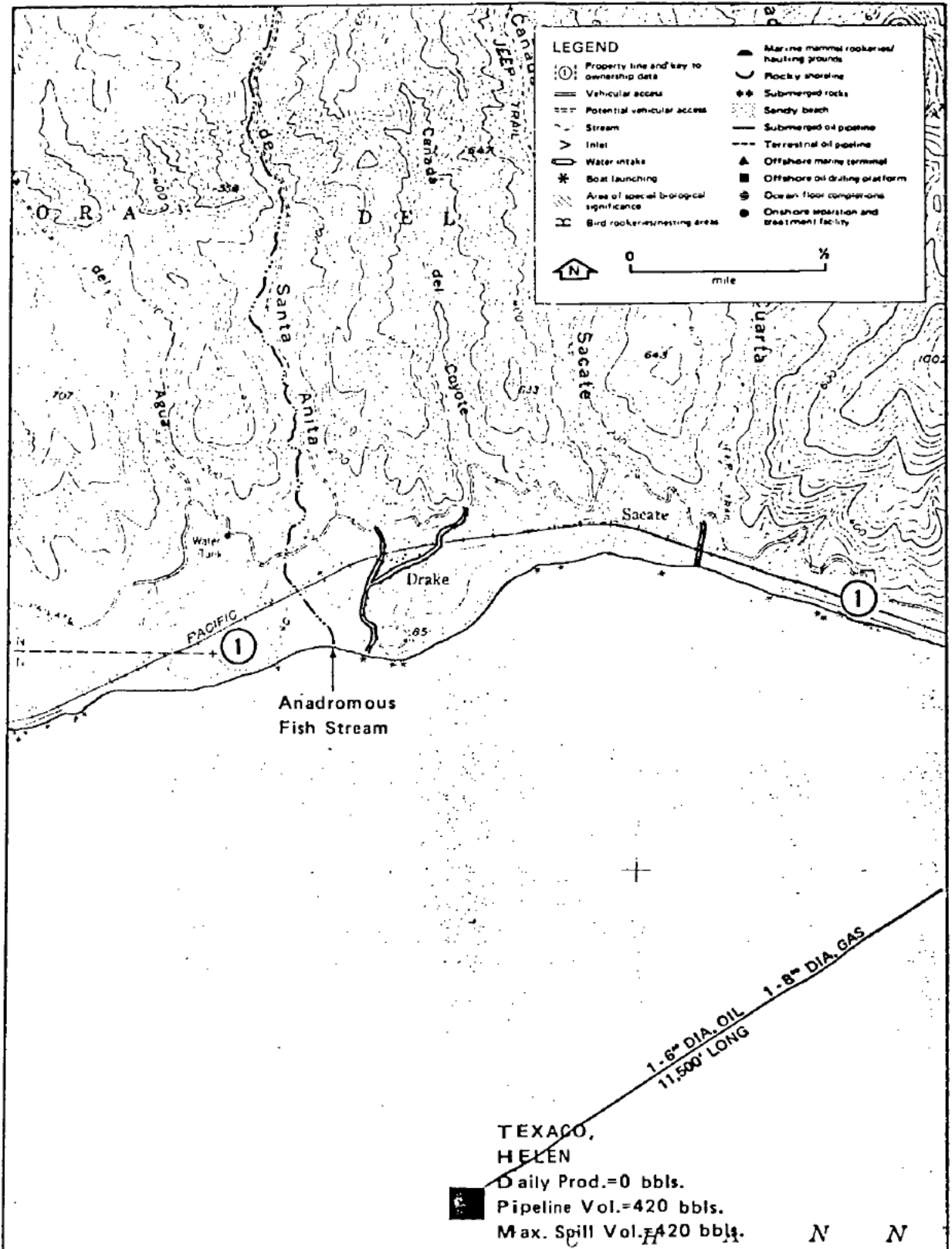

DRAKE

PORT ORFORD

Shoreline Characteristics

General Description: straight, narrow sand/cobble beach - small estuary at Gaviota Beach State Park

Backshore: cliffs

Trafficability: good on sand, poor on cobble

Cleanup Technique Code

(3); temporary disposal site at Gaviota Beach parking area

Access

Principal Entry Points: through Gaviota Beach State Park and along the beach with all types of vehicles, which could be trapped at high tide

Boat Launching Facilities: pier at Gaviota Beach

Inlets/Streams

Inlets: None

Streams: Gaviota Creek is identified by the CC as an anadromous fish stream - numerous intermittent high gradient creeks

Ownership and Control

Principal Property Owner(s):

Address:

(1) James Hollister	(2) State of California	(3) Getty Oil Co.
137 Anapamu St.	Gaviota Beach State Park	P. O. Box 54050
Santa Barbara, CA	Gaviota, California	Los Angeles, CA
Phone: (805) 963-6711	(805) 688-5105	(805) 968-4608
Controlling Government Authority: State of California		
Waterfront Usage: recreation and industrial		

Biological Data

Potential Threat to Wildlife:

Special Biological Significance: South Coast Intertidal Preserve. CC notes that the intertidal zone from Point Conception to Ellwood is particularly valuable. It includes the state's most extensive kelp beds, which support many fish; it should be protected from overuse so that high productivity can be maintained.

Seasonal Factors

Sand may migrate offshore seasonally, exposing rock and terraces.

Special Factors Affecting Spill Control

Gaviota Creek entrance commonly blocked by sand bar. When open can be protected by booming at the railroad trestle or landward.

Comments

Daily there are strong gusty winds out of the pass from afternoon through late night. With bad weather, they often reach gale force.

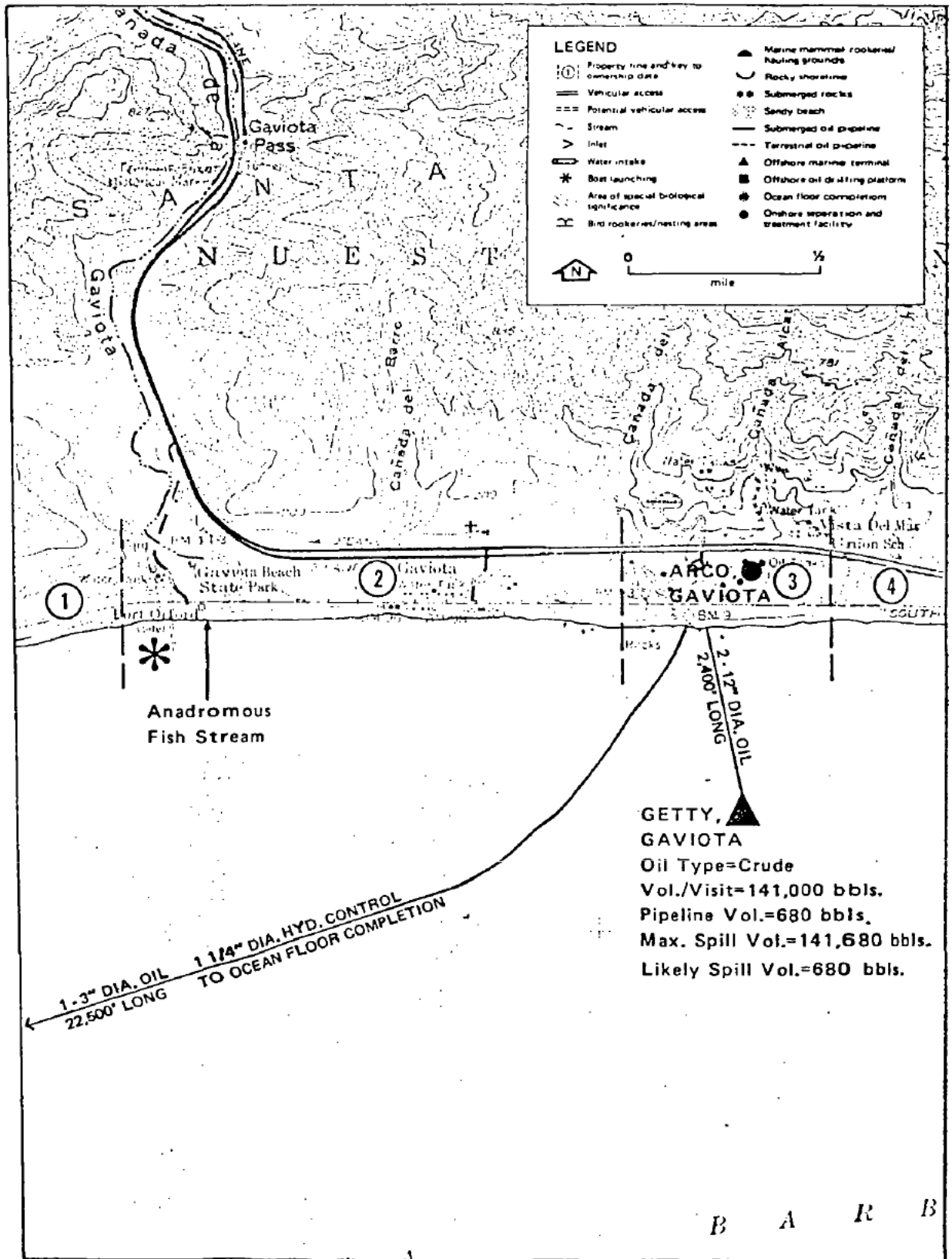

PORT ORFORD

NAPLES

Shoreline Characteristics

General Description: Sandy beaches with a few rocky sections; most beaches are submerged at high tide.

Backshore: Cliffs and steep bluffs

Trafficability: Good on sandy intertidal beaches

Cleanup Technique Code (4)

Access

Principal Entry Points: Rancho Dos Pueblos Canyon Rd.

Boat Launching Facilities: None Nearest: Goleta

Inlets/Streams

Inlets: None

Streams: Several intermittent creeks

Ownership and Control

Principal Property Owner(s):

Address:

(1)	(2)	(3)	(4)
Timothy Doheny	Signal Properties	Crocker-Citizens	Security Pacific
714 W. Olympic	Rancho Los Dos Pueblos	P.O. Drawer HH	Nat. Bank
Los Angeles	Goleta, CA	Santa Barbara	Chembeault, Est.
(213) 748-4307	(805) 968-7546	Branch unknown	Santa Barbara, CA
			Branch unknown

Controlling Government Authority: Santa Barbara County

Waterfront Usage: Limited recreation; oil wells and related activities on bluffs largely natural

Biological Data

Potential Threat to Wildlife: Seals

Special Biological Significance: The Burmah Beach area is also a significant harbor seal nighttime haul-out area (Siva, 1976).

Seasonal Factors

Sand may move offshore seasonally, exposing rocks and terrace.

Special Factors Affecting Spill Control

Harbor seal haul-out area would require special attention.

Comments

A. Wenner has singled out the Naples Beach area as a particularly strategic location because it is in the outer edge of the Santa Barbara Channel eddy (Siva, 1976).

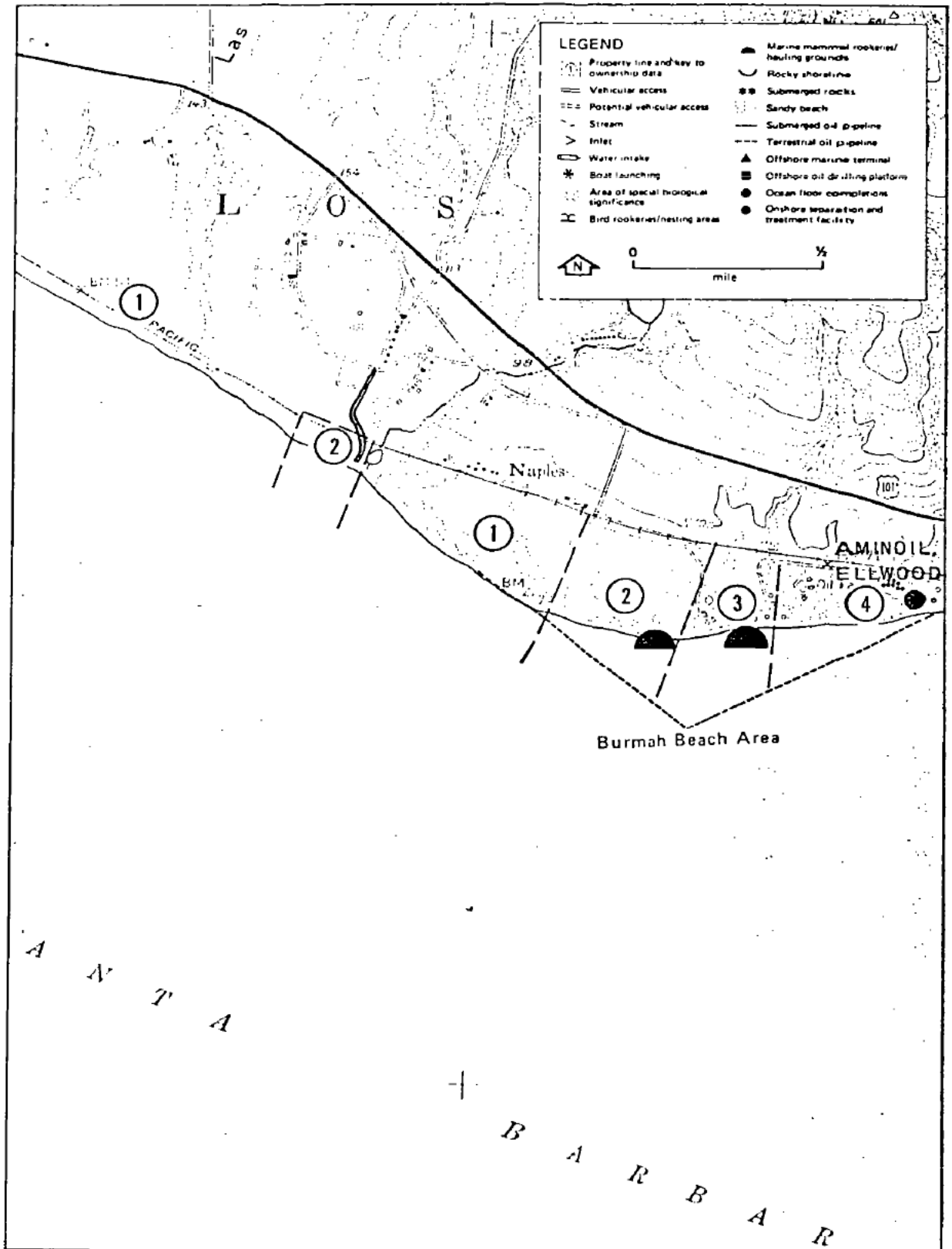

NAPLES

BELL CANYON

Shoreline Characteristics

General Description: rocks, sand, and cobbles
Backshore: steep bluffs
Trafficability: poor on cobbles

Cleanup Technique Code

(3)

Access

Principal Entry Points: Both access points have locked gates. Telephone numbers for access are (805) 968-1404 for Signal Oil gate to the west and (805) 968-2212 for Arco gate to the east.
Boat Launching Facilities: None Nearest: Goleta

Inlets/Streams

Inlets: None
Streams: Tecolote Creek, several high gradient intermittent creeks

Ownership and Control

Principal Property Owner(s):

Address:

(1)	(2)	(3)
Security Pacific Nat. Bank Chembeault, Est. Santa Barbara, CA	Atlantic Richfield Hollister Ave. at Hyw 101 Goleta, CA	Wallover Inc. 640 5th St. New York, N.Y.
Phone: Branch unknown	(805) 998-6312	Unknown

Controlling Government Authority: Santa Barbara County
Waterfront Usage: Recreation and industrial

Biological Data

Potential Threat to Wildlife: Tecolote Creek is identified by the CC as an anadromous fish stream.
Special Biological Significance:

Seasonal Factors

Sand may migrate offshore seasonally, exposing cobbles and rocks.

Special Factors Affecting Spill Control

High energy shoreline - should self-clean rapidly.

Comments

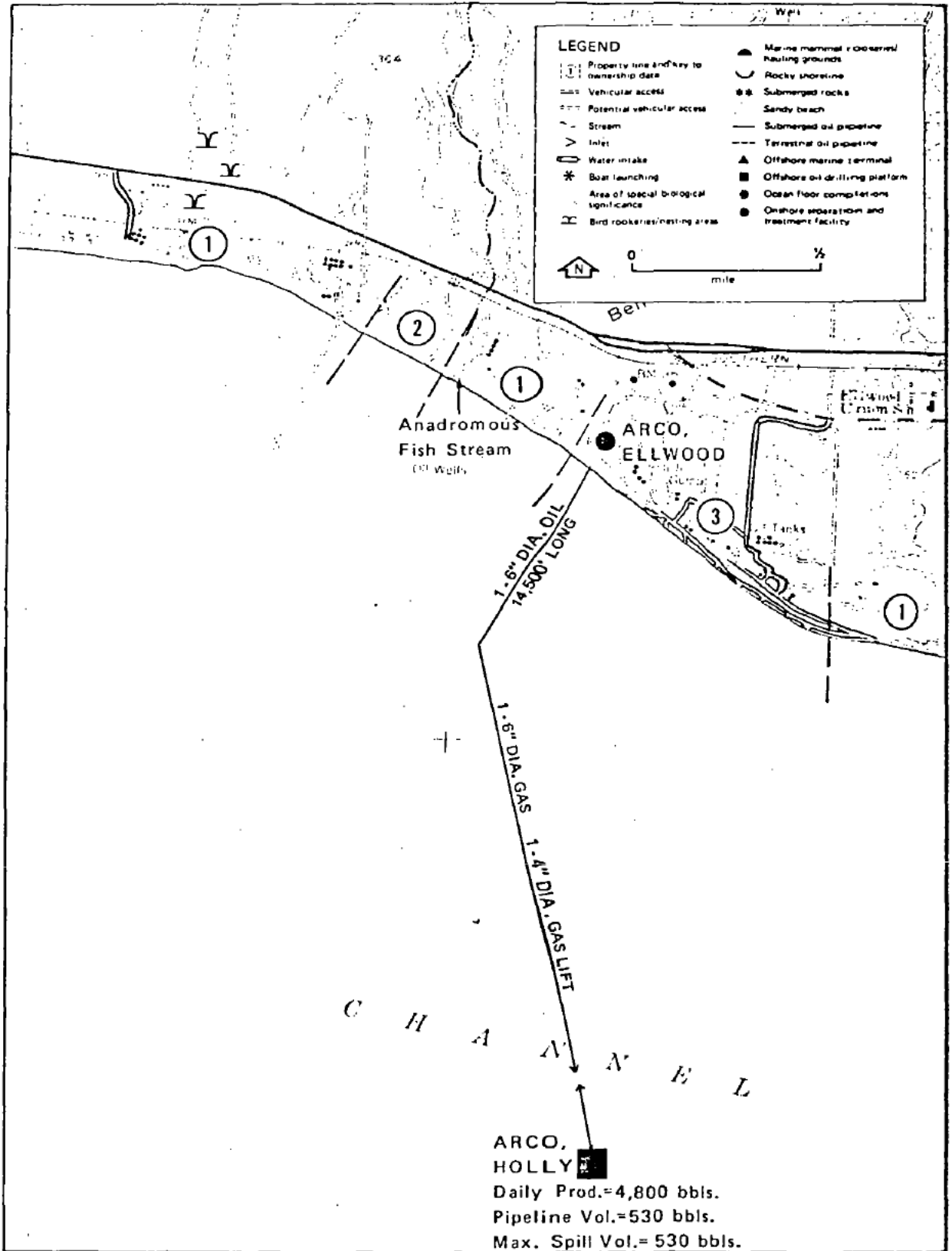

BELL CANYON

COAL OIL POINT

Shoreline Characteristics

General Description: primarily sandy beaches some boulders at Coal Oil Point; estuary at Coal Oil Point

Backshore: a few rocky cliffs, mostly sandy beaches of varying widths backed by steep bluffs

Trafficability: good on intertidal sand, poor on backshore area

Cleanup Technique Code (3); temporary disposal site at oil sump

Access

Principal Entry Points: Access through Devereaux Ranch but backshore is soft and steep. Also in Isla Vista and north of Devereaux Ranch. Estuary entrance may be impassible.

Boat Launching Facilities: None Nearest: Goleta

Inlets/Streams: Inlets: None Streams: Devereaux slough

Ownership and Control

Principal Property Owner(s):

Address:	(1)	(2)	(3)
	Sierra Downs, Inc.	S. Barb Shores Homeowners	A.G. Baydon
	W. Lincoln St.	7959 Pales Verdes Dr.	Coronado del
	Anaheim, CA	Goleta, CA	Mar Ranch
			Goleta, CA

Phone:

Unlisted

(805) 968-6044

Unlisted

(4)

State of California
Division of Parks and Beaches
411 Canon Perdido, Santa Barbara

Phone: (305) 967-3494

Controlling Government Authority:

Waterfront Usage:

Biological Data

Potential Threat to Wildlife: Pinniped haul-out sites located at Devereaux Slough/Coal Oil Point

Special Biological Significance: Devereaux Slough is a large lagoon-slough complex (fifteen acres of marshland and thirty acres of water) that is bordered by sand dunes; it may sometimes be open to the sea during very wet months. It is included in the Coal Oil Point Reserve of the University of California Natural Land and Water Reserve System (Siva, 1976).

Seasonal Factors

Estuary normally closed by bar. Sand may move offshore seasonally, exposing rock and cobbles.

Special Factors Affecting Spill Control

Devereaux Slough would have to be boomed if open to ocean. See Map 700-3 (end of section) for special booming procedures. Sand dunes in Coal Oil Point Reserve are protected and should not be disturbed by heavy equipment.

Comments

Area receives chronic contamination from natural offshore seeps.

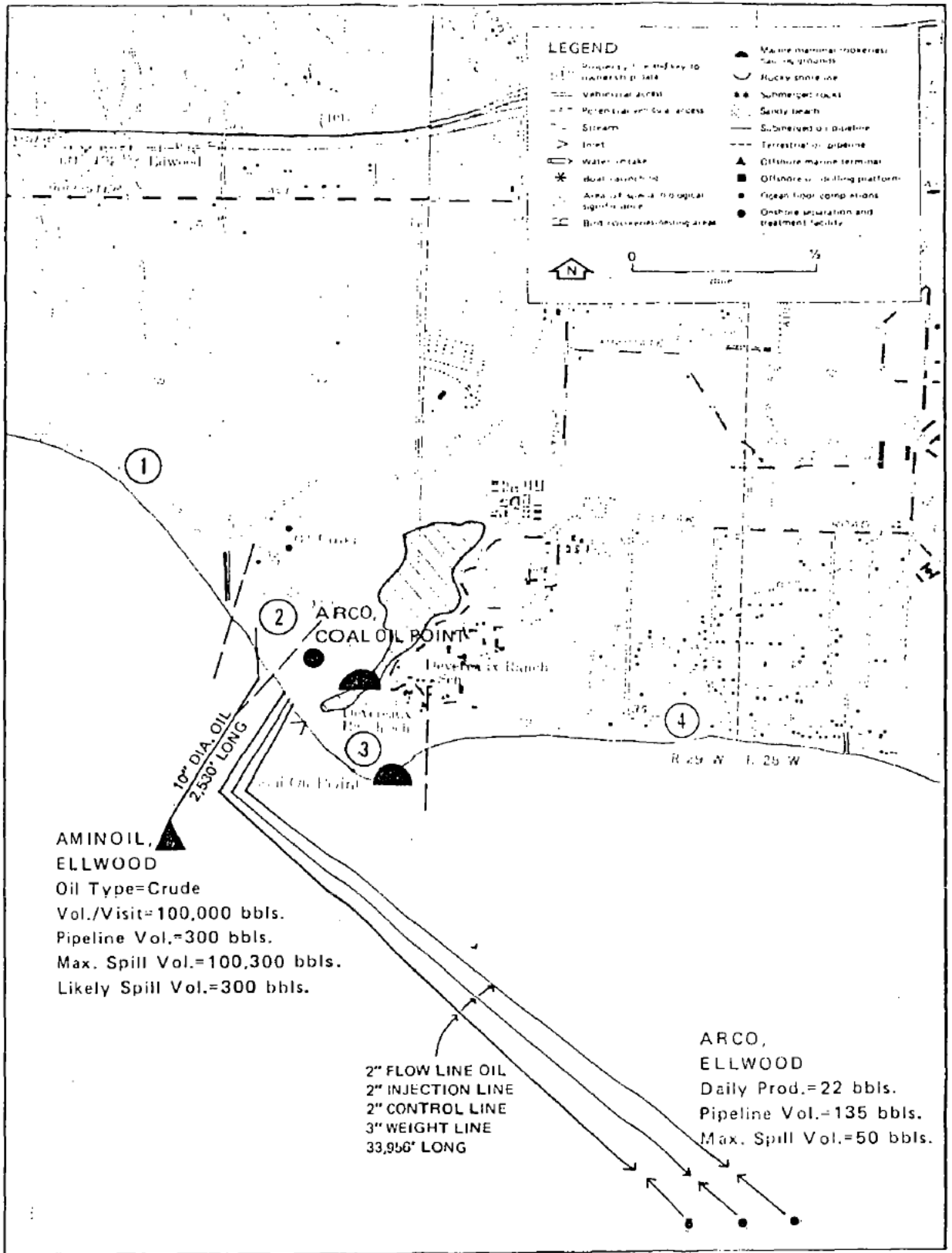

COAL OIL POINT

GOLETA POINT

Shoreline Characteristics

General Description: predominantly sandy beach except for rocky area at Goleta Point
Backshore: sloughs and wetlands backing Goleta Point and Goleta Beach, otherwise high bluffs or cliffs
Trafficability: good on foreshore; backshore soft

Cleanup Technique Code

(3) temporary disposal site at Goleta Point and Beach parking lot

Access

Principal Entry Points: access at Goleta beach & just west of Goleta Point
Boat Launching Facilities: Goleta Pier

Inlets/Streams

Inlets: Goleta Slough
Streams: Goleta Slough

Ownership and Control

Principal Property Owner(s):

Address: (1) State of California	(2) Santa Barbara County
Division of Parks and Beaches	Parks Administration
411 Canlon Perdido, Santa Barbara	123 Anapamu
Phone: (805) 967-3494	(805) 966-1611

(3) More Mesa Homeowners Assn.
Santa Barbara, CA
Each owner has key to beach
Mr. Grahn and others

Phone: (805) 967-6460
(805) 964-2252 and 967-2200

Controlling Government Authority: 1) State of California, 2,3) Santa Barbara County

Waterfront Usage: Recreation

Biological Data

Potential Threat to Wildlife: Birds and harbor seals

Special Biological Significance: Goleta Rocks - A rocky outcrop near Goleta is used regularly by harbor seals as a daytime haul-out area (Siva, 1976). Goleta Slough - This area includes about 125 acres of productive salt marsh, a lagoon, and unvegetated tidal flats. The slough opens to the ocean via a broad channel, which is occasionally closed by the formation of a sand bar. More than 75 bird species spend about 150,000 bird-days in the marsh per year. It is used as a study and educational area by local university, school, and environment groups (Siva, 1976). Habitats for two endangered species, the light-footed clapper rail and Belding's savannah sparrow, are located at Goleta Slough. University Lagoon is a highly productive, brackish water lagoon; its opening to the sea is presently blocked by a sand bar (Siva, 1976).

Seasonal Factors

Special Factors Affecting Spill Control: If Goleta slough is open it would have to be boomed landward from the entrance in an area of low current. See Map 700-4 (end of section) for special booming procedures.

Comments

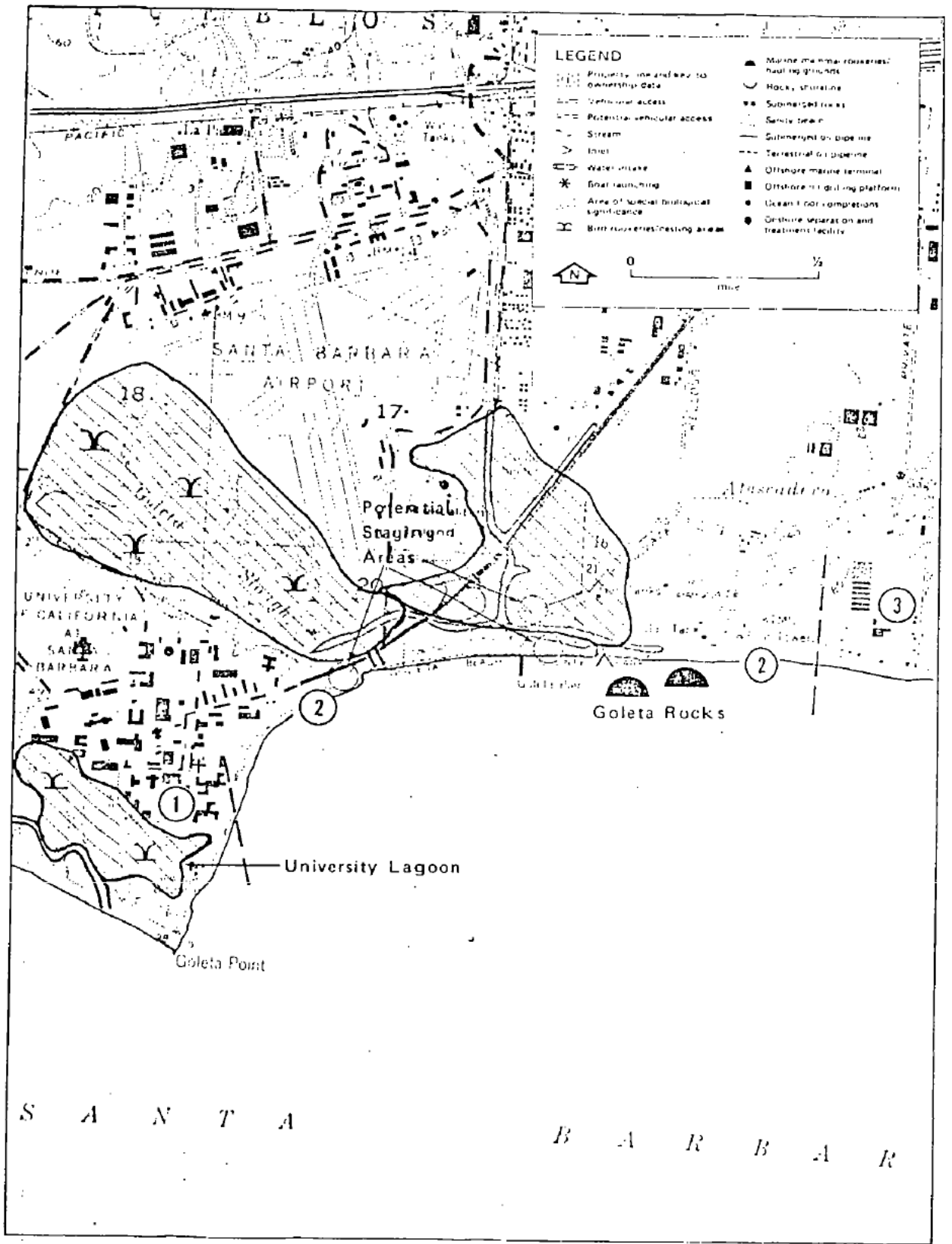

GOLETA POINT

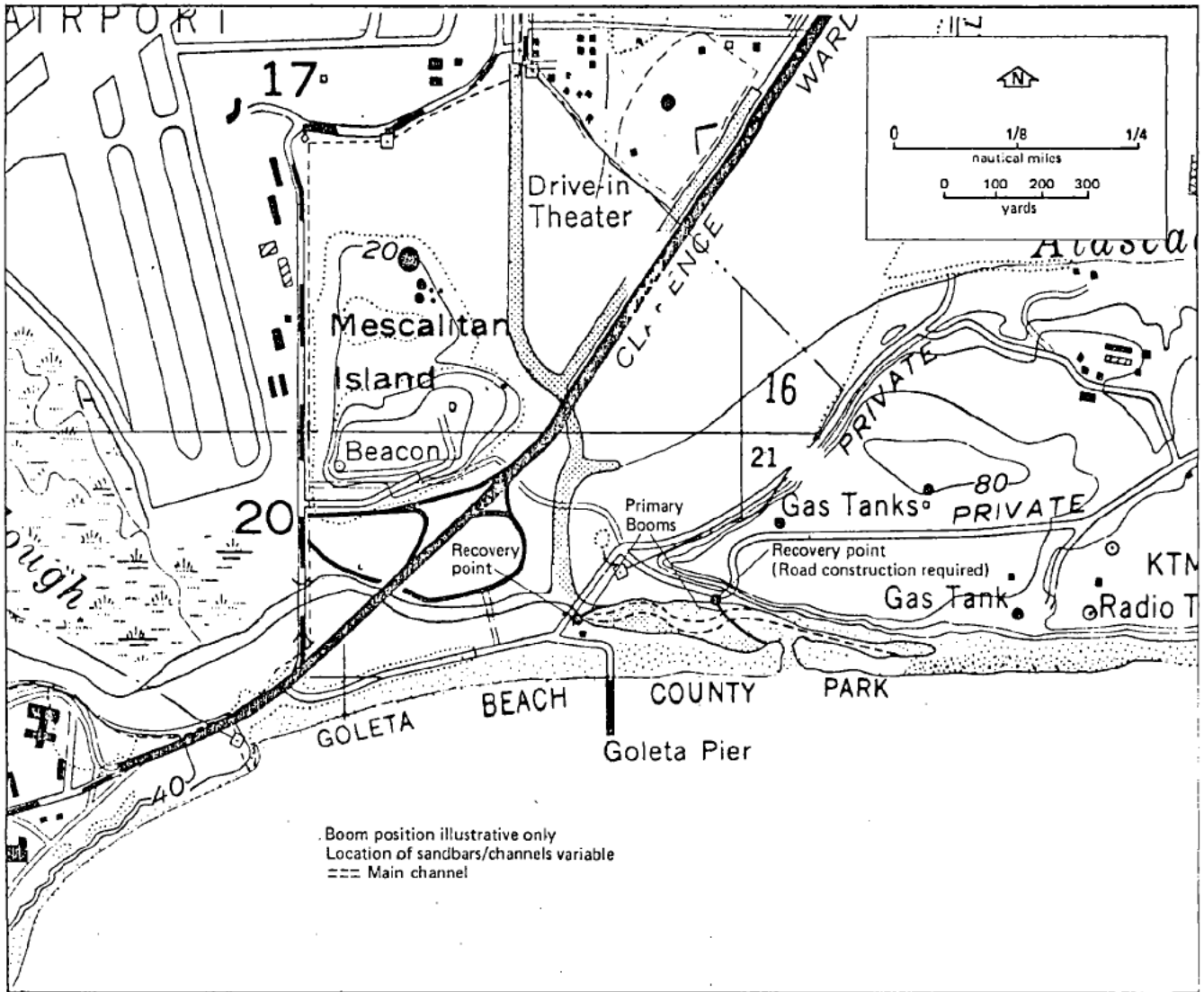

GOLETA SLOUGH

SAND POINT

Shoreline Characteristics

General Description: rip-rap north of Sandyland; remainder consists of short sandy stretches of beach between rocky sections.

Backshore: low sand dunes

Trafficability: good on sand beach intertidal area

Cleanup Technique Code

(2) in bird sanctuary, (3) elsewhere: temporary disposal site at beach parking area

Access

Principal Entry Points: Private access at Sandyland and Sandyland Cove.

Easy vehicular access at Carpinteria Beach and the area east

Boat Launching Facilities: None Nearest: Chevron Pier

Inlets/Streams: Carpinteria Creek; El Estero Slough

Ownership and Control: Principal Property Owner(s):

Address:	(1) Myrtle Lawler 818 Hot Springs Rd Santa Barbara	(2) Spindrift Land/Sandyland Cove 863 Spindrift Lane Carpinteria, CA
Phone:	(805) 969-2648	(805) 483-2649

	(3) State of California Carpinteria State Beach Carpinteria, CA	(4) State of California Division of Parks and Beaches Santa Barbara
Phone:	(805) 584-4714	(805) 967-3494

Controlling Government Authority: State of California

Waterfront Usage: 1, 3 and 4) Recreation, 2) Bird sanctuary

Biological Data

Potential Threat to Wildlife: Birds, wetland

Special Biological Significance: El Estero, or Carpinteria Slough. This marsh complex is the largest in Santa Barbara County, with 150 acres of marsh, 35 acres of mudflats, and 15 acres of tidal channels. It communicates with the ocean via a channel that opens at Sand Point. More than 120 bird species have been identified from the marsh area, representing some 170,000 bird-days of use per year (Siva, 1976). Habitats for two endangered species, the light-footed clapper rail and the Belding's savannah sparrow, are located in El Estero Slough.

Seasonal Factors

Sand may migrate on- and offshore seasonally.

Special Factors Affecting Spill Control

Entrance to Estero Slough may have to be boomed or barred. See Map 700-6 (end of section) for special booming procedures.

Comments

Natural seeps occur in State Park.

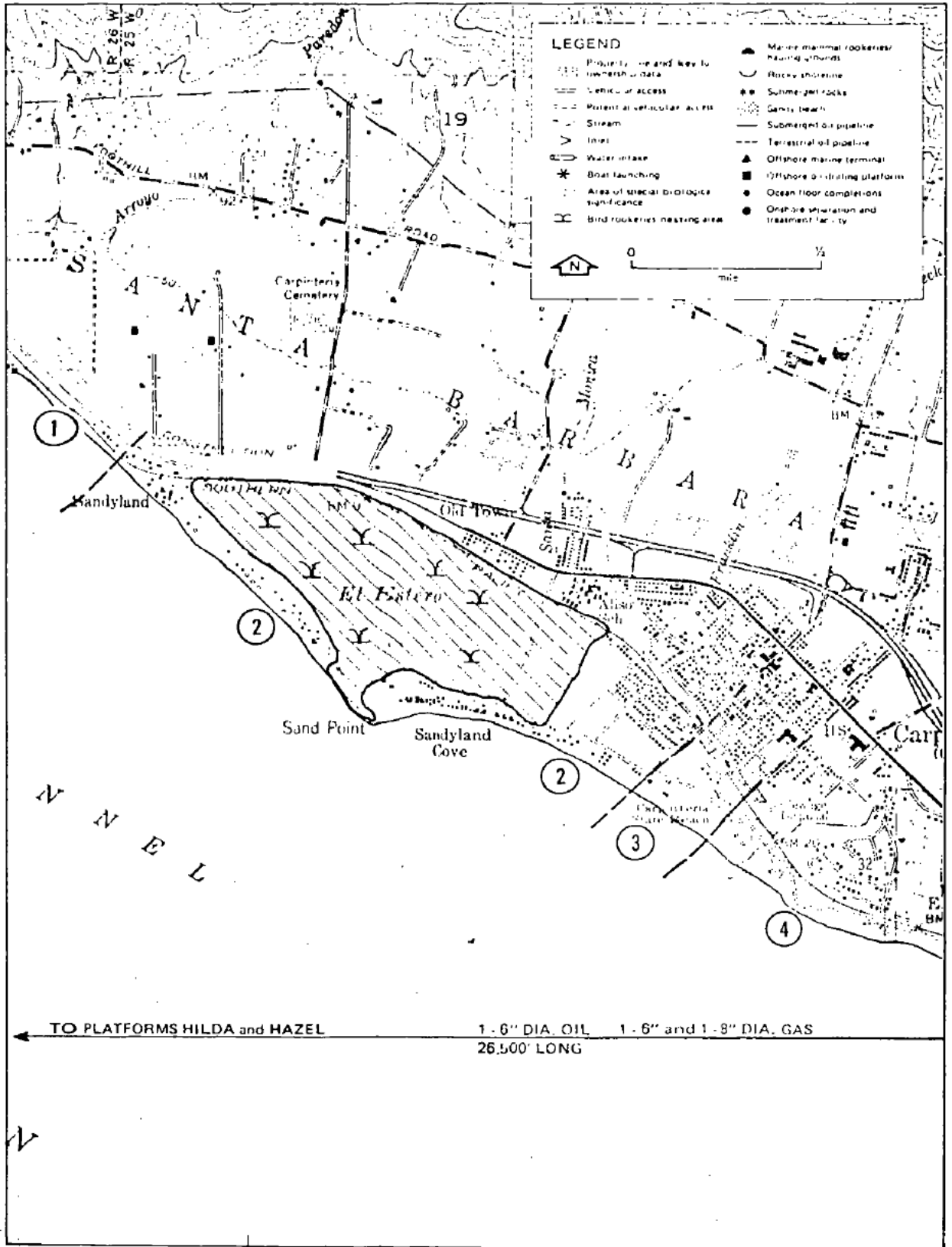

SAND POINT

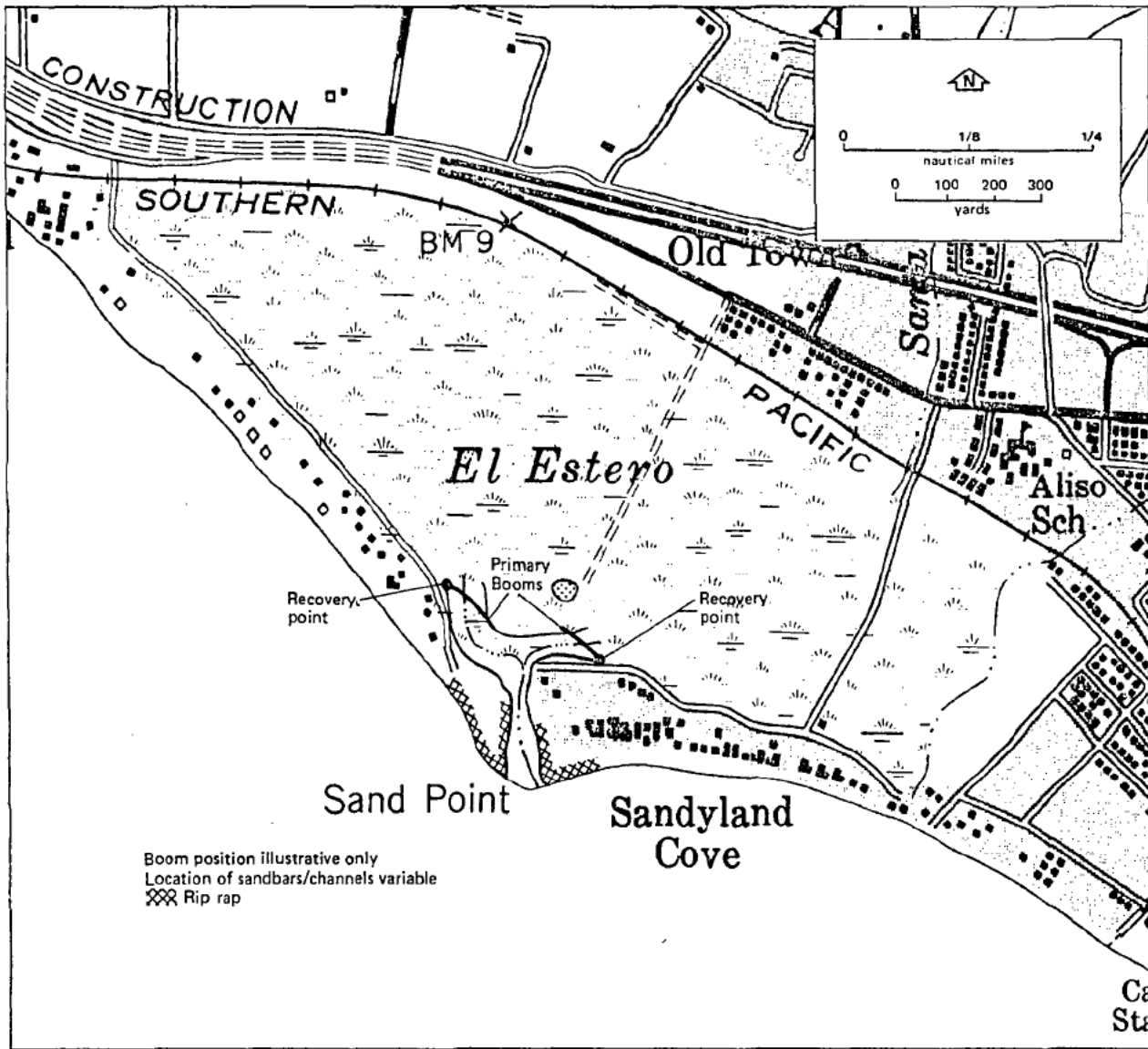

EL ESTERO SLOUGH

EL RINCON

Shoreline Characteristics

General Description: narrow sandy beach; many areas underwater at high tide
Backshore: cliffs
Trafficability: unknown

Cleanup Technique Code

(2) near Chevron Pier, (3) elsewhere

Access

Principal Entry Points: Chevron Pier
Boat Launching Facilities: Chevron Pier

Inlets/Streams

Inlets: None
Streams: Rincon Creek

Ownership and Control

Principal Property Owner(s):

Address:

(1)
State of California
Division of Parks and Beaches
Santa Barbara, CA

Phone: (805) 967-3494

Controlling Government Authority: State of California

Waterfront Usage: Recreation

Biological Data

Potential Threat to Wildlife: Marine mammals, intertidal habitats

Special Biological Significance: Standard Oil Pier: A significant harbor seal nighttime haul-out area (Siva, 1976). Carpinteria Intertidal Reef: The Coastal Commission identifies this as the most diverse intertidal area in Santa Barbara County, south of Point Arguello. It is regarded as fragile.

Seasonal Factors

Sand may migrate offshore seasonally exposing rocks and cobbles. Small lagoon at Rincon Point may be open seasonally.

Special Factors Affecting Spill Control

Special consideration should be given to cleaning of haul-out areas.

Comments

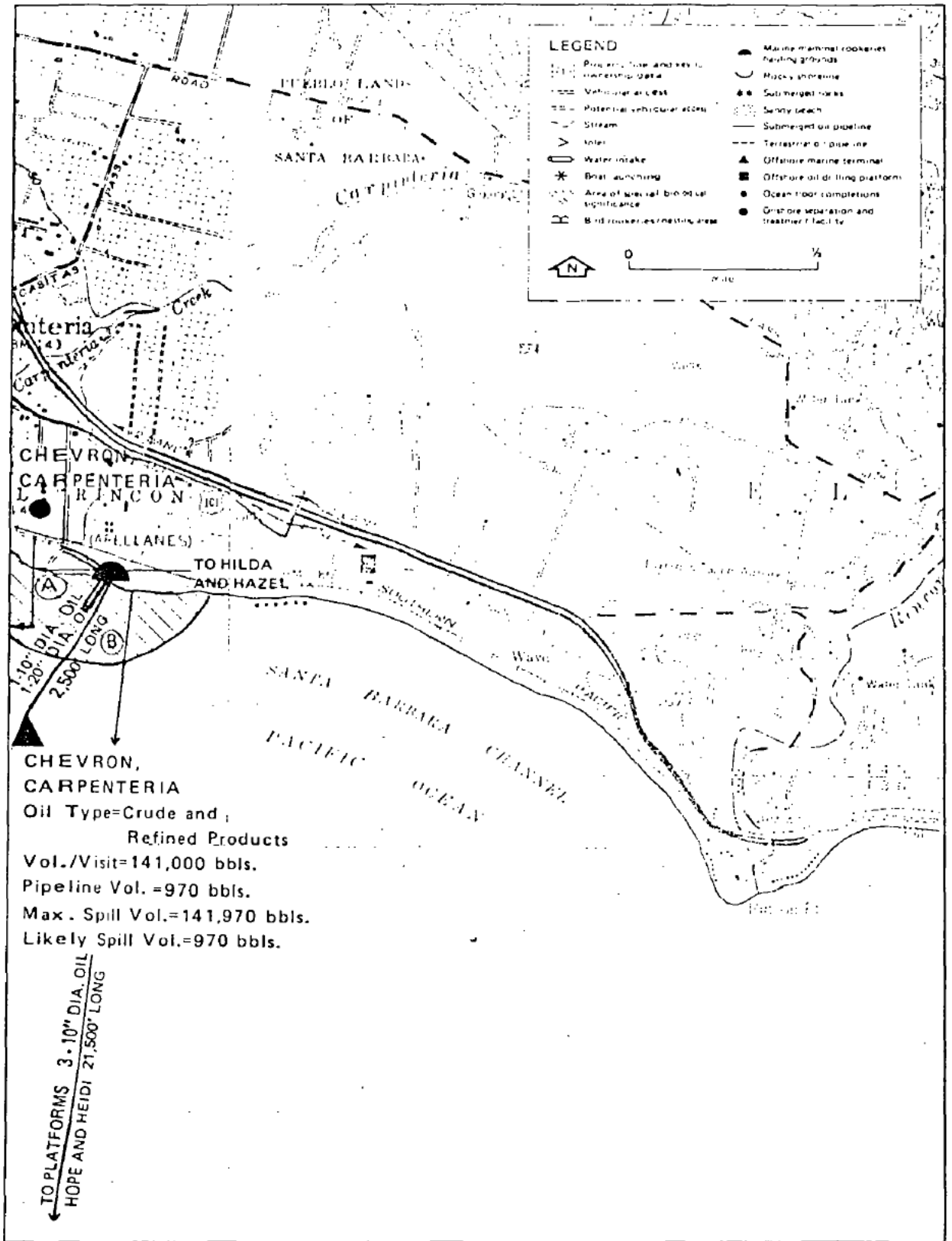

EL RINCON

VENTURA RIVER

Shoreline Characteristics

General Description: A) Cobble beach B) flat sandy beach entrance to
Ventura River C) cobble beach

Backshore: narrow and steep with seawalls protecting Highway 101
to the north; marshland to the south

Trafficability: good on sandy beach, poor on cobbles

Cleanup Technique Code

(3); temporary disposal site at Babe Ruth Field parking area

Access

Principal Entry Points: From fairground road in Section C - mouth of
Ventura River may be impossible to cross.

Boat Launching Facilities: None Nearest: Ventura Marina

Inlets/Streams

Inlets: Allesandro Lagoon

Streams: Ventura River

Ownership and Control

Principal Property Owner(s):

Address:

(1)	(2)	(3)
Emma Wood	State of California	Ventura Cnty
State Bch	Department of Highways	Fair Grounds
Ventura, CA	157 So Garden	Seaside Park
Phone:	(805) 648-2771	(805) 643-5547

Controlling Government Authority: State of California

Waterfront Usage: Recreation

Biological Data

Potential Threat to Wildlife:

Special Biological Significance: Allesandro Lagoon includes wetland
habitat. First and second mouths of the Ventura River support a
small marsh area (five acres of marsh, five acres of water) which
is considered to be important because the adjacent area is gener-
ally arid (OCS, 1975). It is an anadromous fish stream with fishery
potential.

Seasonal Factors

Cobble beaches may be seasonal. Probably will become sandy during spring
and summer. Mouth of Ventura River seasonally barred.

Special Factors Affecting Spill Control

Opening to Allesandro Lagoon and Ventura River estuary can be blocked
with sand or possibly boomed.

Comments

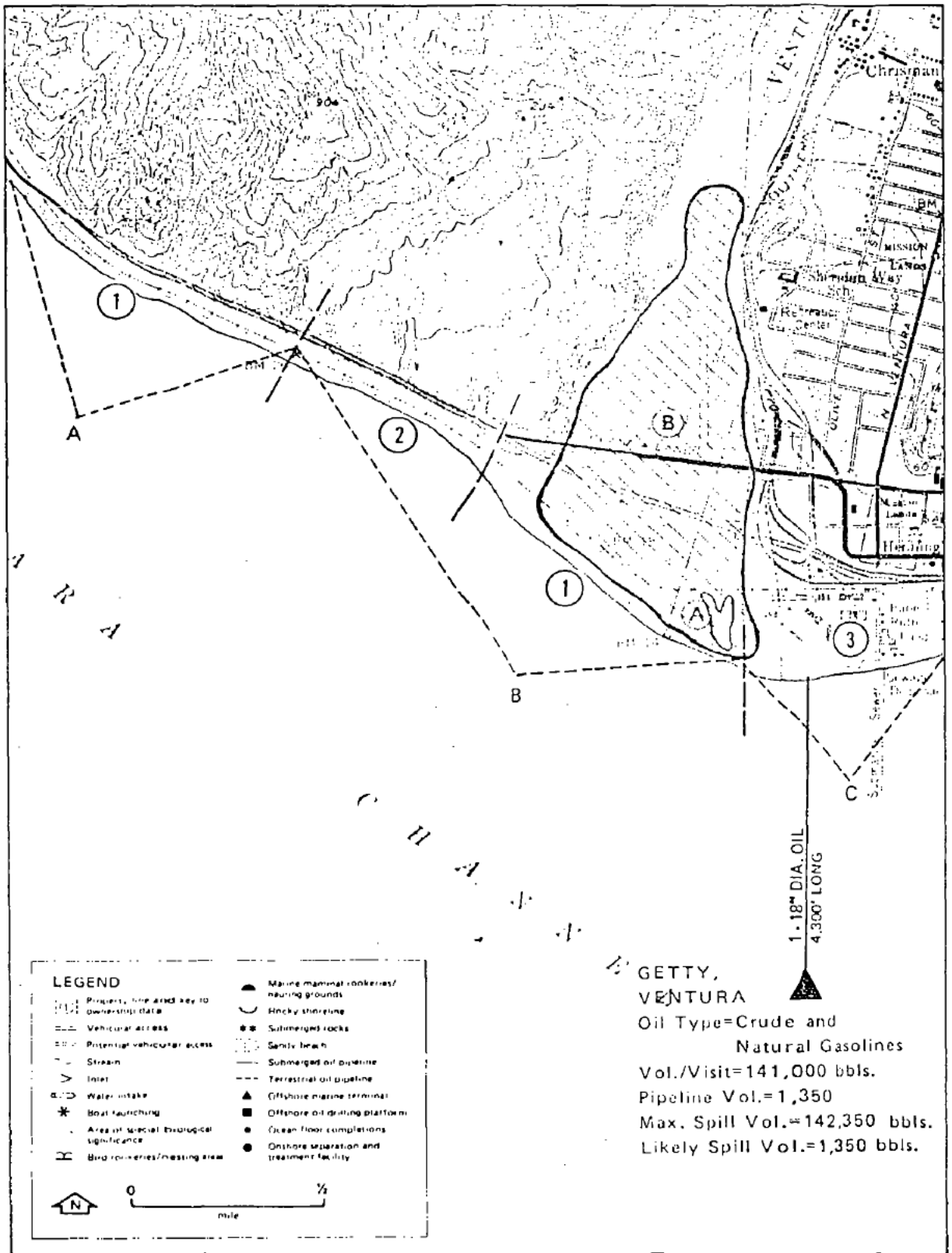

LEGEND

▭ Property line and key to ownership data	● Marine mammal rookeries/hauling grounds
▭ Vehicular access	☾ Rocky shoreline
▭ Potential vehicular access	● Submerged rocks
▭ Stream	● Sandy beach
▭ Inter	▭ Submerged oil pipeline
▭ Water intake	▭ Terrestrial oil pipeline
* Boat launching	▲ Offshore marine terminal
▭ Area of special biological significance	■ Offshore oil drilling platform
▭ Bird rookeries/nesting area	● Ocean floor completion
	● Onshore separation and treatment facility

0 1/2 mile

GETTY,
VENTURA
Oil Type=Crude and
Natural Gasolines
Vol./Visit=141,000 bbls.
Pipeline Vol.=1,350
Max. Spill Vol.=142,350 bbls.
Likely Spill Vol.=1,350 bbls.

VENTURA RIVER

VENTURA

Shoreline Characteristics

General Description: flat sandy beach, entrance Ventura Marina
Backshore: sand dunes
Trafficability: good

Cleanup Technique Code

(3); temporary disposal sites at State Beach parking areas

Access

Principal Entry Points: totally accessible since most streets end
at beach; limited access at McGrath Beach to the south
Boat Launching Facilities: Ventura Marina

Inlets/Streams

Inlets: None
Streams: Santa Clara River - artificial opening at mouth of river

Ownership and Control

Principal Property Owner(s):

Address:

(1)	(2)	(3)
City of San Buena Ventura	Buena Ventura	State of California
625 E. Santa Clara	State Beach	McGrath Beach State Park
Ventura, CA	Ventura, CA	Ventura, CA
Phone: (805) 643-9911	(805) 643-5447	(805) 643-5447

Controlling Government Authority: State of California
Waterfront Usage: Recreation

Biological Data

Potential Threat to Wildlife: Waterfowl
Special Biological Significance: Santa Clara River Estuary. The river
forms some large lagoons with associated tidal flats near its
mouth. About sixty acres of salt marsh are associated with this
habitat (Siva, 1976).

Seasonal Factors

Sand may migrate on- and offshore seasonally, entrance to Santa Clara
River Estuary seasonally barred.

Special Factors Affecting Spill Control

Ventura Marina would have to be boomed. If Santa Clara River Estuary
is open it would require booming or blocking by pushing sand into
entrance channel. See Map 700-7 (end of section) for special booming
procedures.

Comments

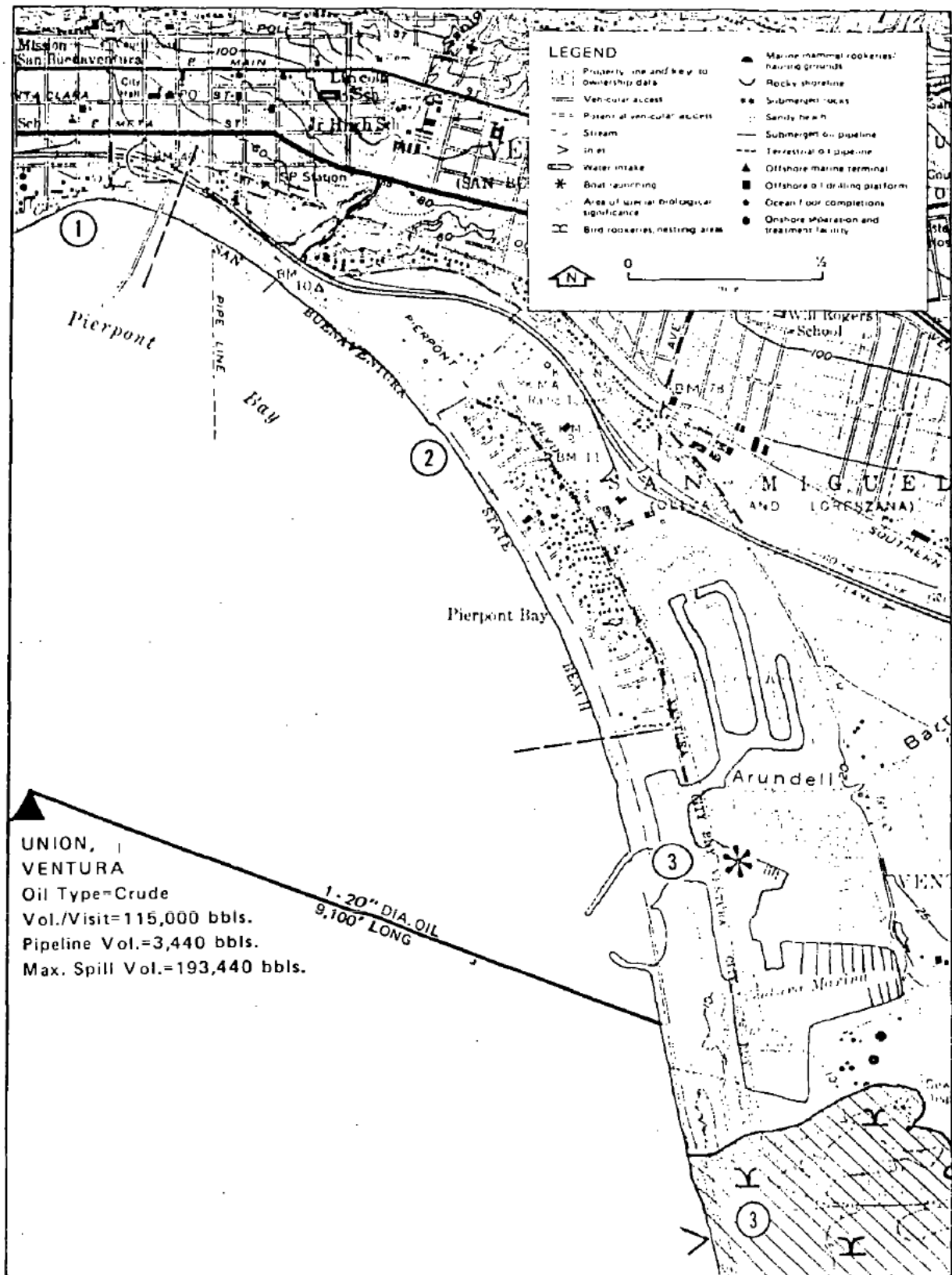

VENTURA

RIO DE SANTA CLARA

Shoreline Characteristics

General Description: flat sandy beach

Backshore: wide backshore, primarily sand dunes

Trafficability: fair to good in sandy intertidal area

Cleanup Technique Code

(3); temporary disposal site at empty lot at end of Arnold Road

Access

Principal Entry Points: Arnold Road to the north, base security for access south of Arnold Road

Boat Launching Facilities: None Nearest: Channel Islands Harbor

Inlets/Streams

Inlets: None

Streams: None

Ownership and Control

Principal Property Owner(s):

Address:

U.S. Navy Base Point Mugu
Pacific Missile Range
Point Mugu, California

Phone:

(805) 982-7907

Controlling Government Authority: U.S. Navy

Waterfront Usage: Limited Recreational use by navy personnel

Biological Data

Potential Threat to Wildlife: Bird nesting areas and a pinniped haul-out site is located at the sand flats in Mugu Lagoon.

Special Biological Significance: Mugu Lagoon. The wetlands located at Mugu Lagoon are considered to be the most important in Ventura county, with 1420 acres of marsh, 500 acres of mud flat, and 250 acres of water. This comprises 95 percent of the county total (OCS, 1975). The area has remained pristine because the Navy has maintained it as open space and has limited public access. It is a major stopover for birds on the Pacific Flyway during both spring and fall migrations. More than 200 species, including several rare or endangered bird species, have been sighted at Mugu, and some of these nest in the lagoon area. The lagoon opens to the sea through a variable channel that must at times be kept open by dredging (Siva, 1976). Habitats for the endangered species, California Least tern are located in Mugu Lagoon.

Seasonal Factors

Sand may migrate on- and offshore seasonally.

Special Factors Affecting Spill Control

Comments

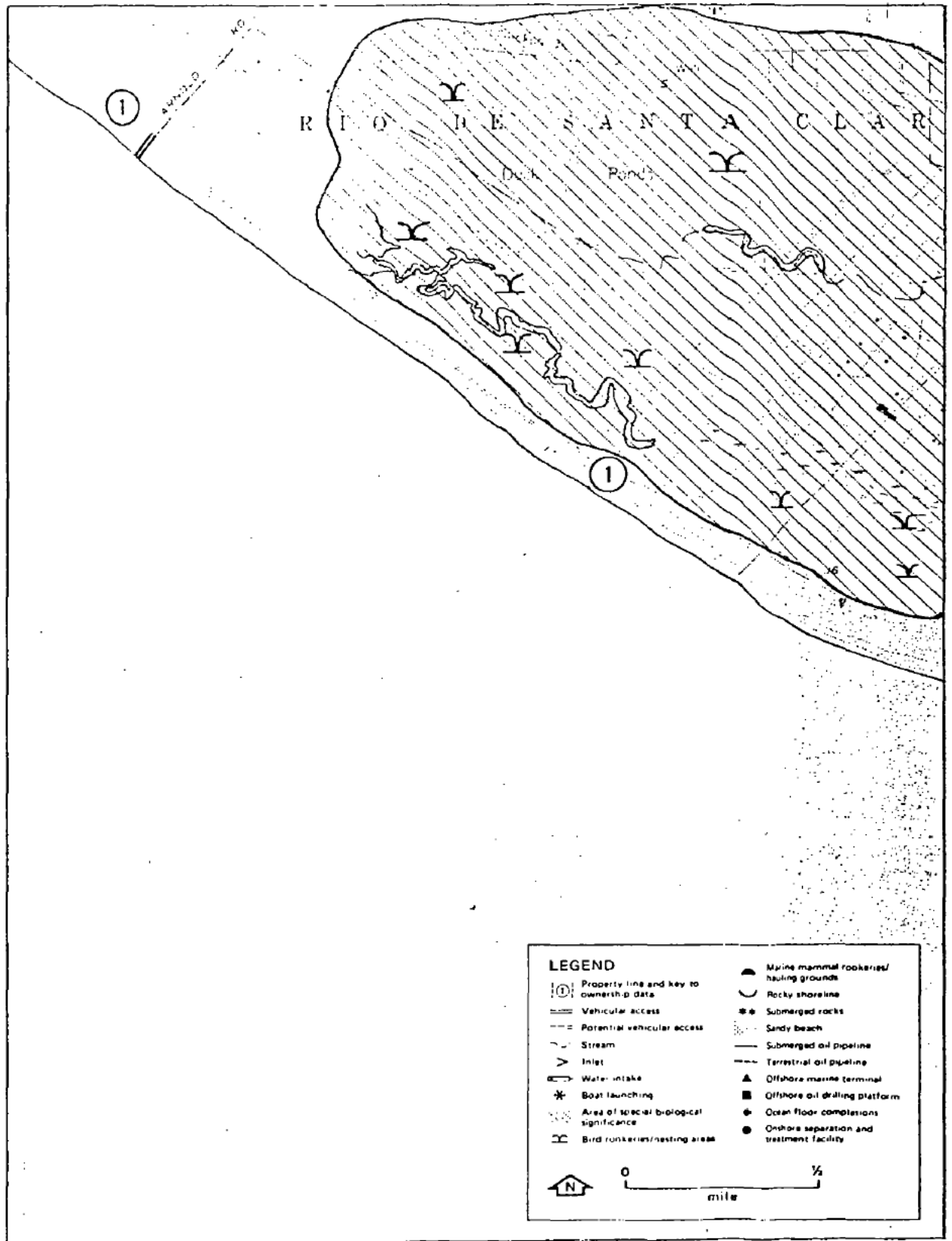

RIO DE SANTA CLARA

LAGUNA POINT

Shoreline Characteristics

General Description: Predominantly sandy beach; eastern section is a sand bar.

Backshore: sand dunes

Trafficability: good on sandy intertidal area

Cleanup Technique Code: (2) Mugu Lagoon, (3) elsewhere; temporary disposal site beside Hwy 1 north of Mugu Rock

Access

Principal Entry Points: At Laguna Pt. through U.S. Navy Base Point Mugu Security (805) 982-7907; no passage across Mugu Lagoon entrance.

Boat Launching Facilities: Navy has boats for use in lagoon.

Inlets/Streams: Inlets: Mugu Lagoon (Calleguas Creek). Streams: Calleguas Creek

Ownership and Control: Principal Property Owner(s):

Address: U.S. Navy Point Mugu
Pacific Missile Range
Point Mugu, CA

Phone: (805) 982-7907

Controlling Government Authority: U.S. Navy

Waterfront Usage: Limited Recreation (Lagoon: natural)

Biological Data

Potential Threat to Wildlife: Many bird nesting areas in lagoon wetlands along with a pinniped haul-out site at the sand flats.

Special Biological Significance: Mugu Lagoon. The wetlands located at Mugu Lagoon are considered the most important in Ventura County, with 1420 acres of marsh, 500 acres of mudflat, and 250 acres of water. This comprises 95 percent of the county total (OCS, 1975). The area has remained pristine because the Navy has maintained it as open space and has limited public access. It is a major stopover for birds on the Pacific Flyway during both spring and fall migrations. More than 200 species, including several rare or endangered bird species, have been sighted at Mugu, and some of these nest in the lagoon area. The lagoon opens to the sea through a variable channel that must at times be kept open by dredging (Siva, 1976). Habitats for the endangered species, the California Least tern, are located in Mugu Lagoon.

Seasonal Factors

Sand may migrate on- and offshore seasonally. Entrance to Mugu Lagoon open continually.

Special Factors Affecting Spill Control

Pollutants could easily be transported across the sand bar into the tidal ponds and lagoon. Booms should be deployed inside of entrance beyond high current area. See Map 700-10 (end of section) for special booming procedures.

Comments

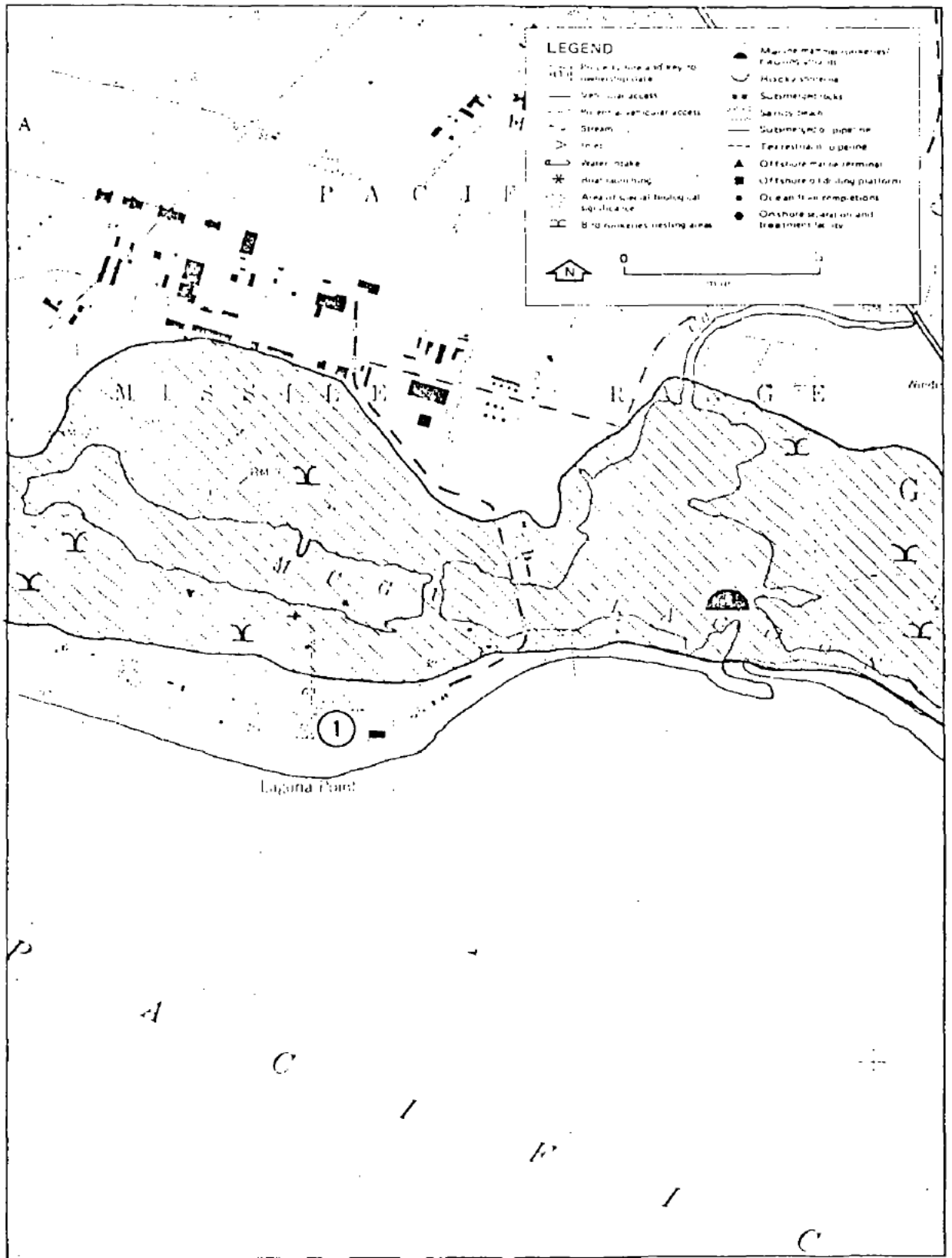

LAGUNA POINT

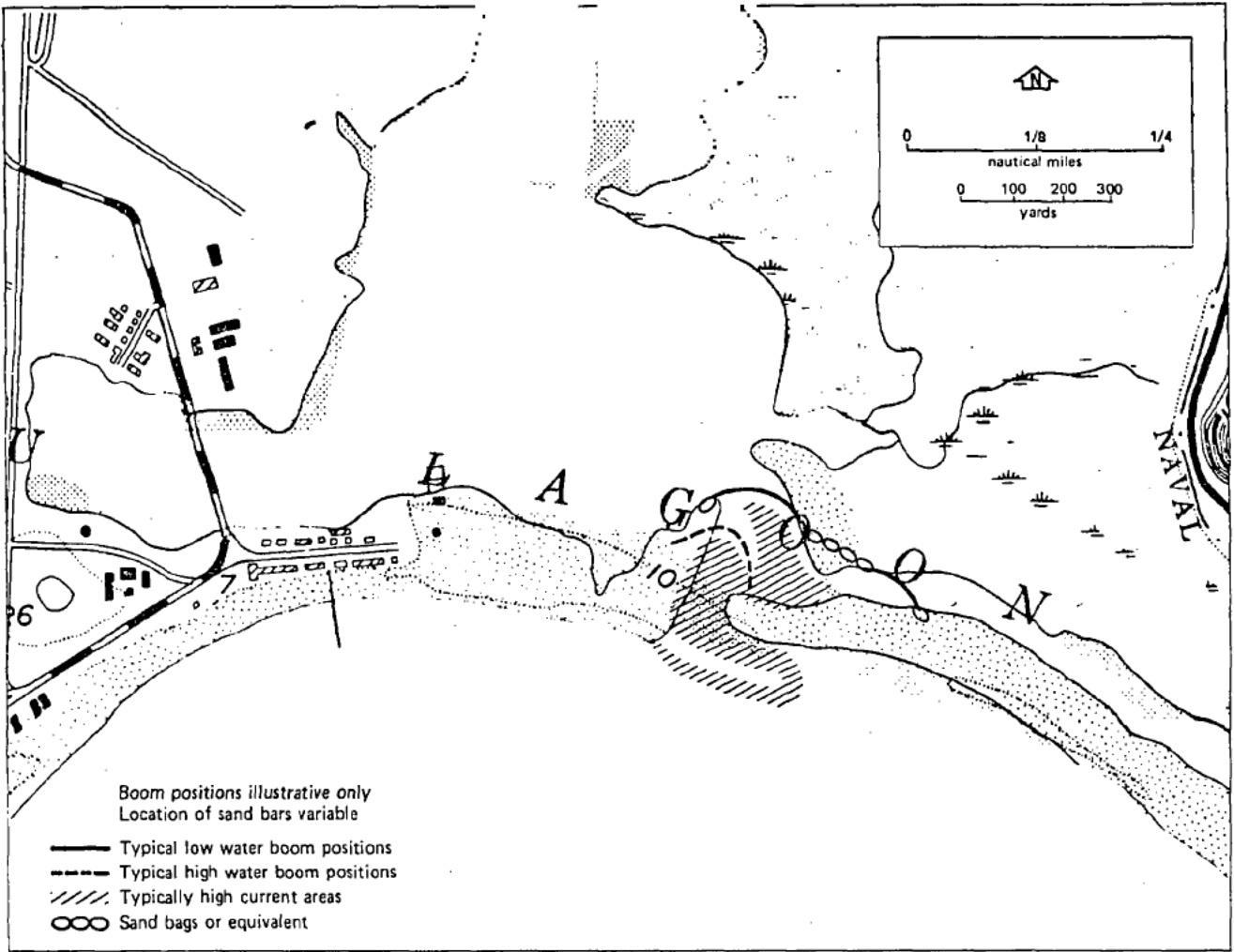

MUGU LAGOON

POINT MUGU

Shoreline Characteristics

General Description: A) sandy beach backed by sand dunes, B) cliffs into the water, no beach
Backshore: A) sand dunes
Trafficability: A) undetermined
B) inaccessible to mobile equipment

Cleanup Technique Code

(3) for A, (4) for B

Access

Principal Entry Points: South end of Naval Reservation with potential access extending north along beach area
Boat Launching Facilities: Navy has boats for use in the lagoon.

Inlets/Streams

Inlets: None
Streams: None

Ownership and Control

Principal Property Owner(s):

Address:

(1)	(2)
U.S. Navy Base Point Mugu	State of California
Pacific Missile Range	Parks and Recreation Dept.
Point Mugu, CA	Ventura, CA
Phone: (805) 982-7907	(805) 643-5447

Controlling Government Authority: U.S. Navy and State of California
Waterfront Usage: Very limited recreation by navy personnel; mostly natural

Biological Data

Potential Threat to Wildlife: Many bird rookeries inside lagoon area
Special Biological Significance: Mugu Lagoon to Latigo Point is an area of special biological significance that includes extensive kelp beds and nearshore rocky areas.

Seasonal Factors

Sand may migrate on- and offshore seasonally.

Special Factors Affecting Spill Control

High energy environment along cliffs; high potential for natural cleaning

Comments

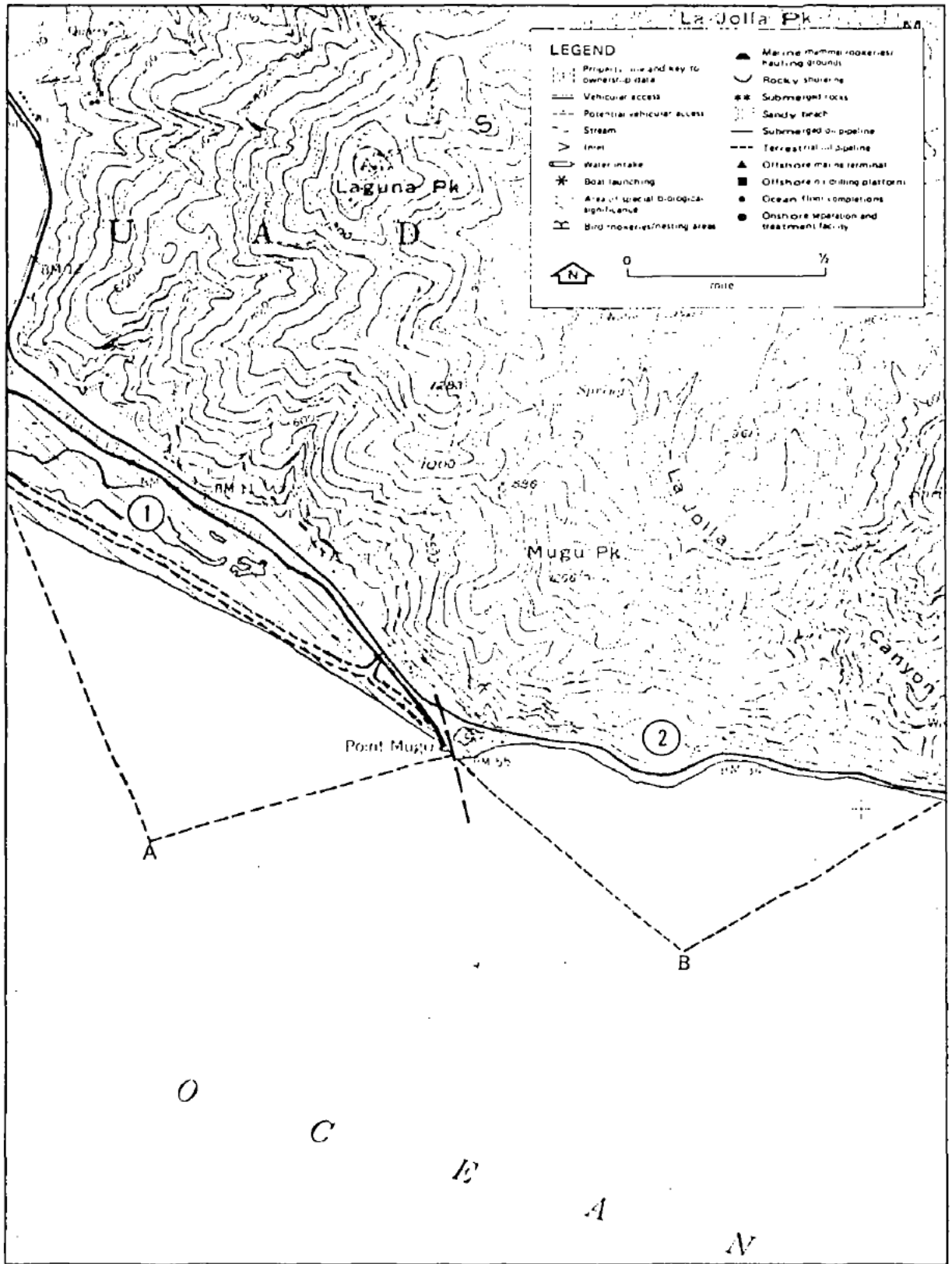

POINT MUGU

SAN MIGUEL ISLAND

Shoreline Characteristics

General Description: Predominantly steep, cliffs with occasional sand/gravel pocket beaches and rocky shoreline sections.

Backshore: A few large, flat, sandy beaches are located at the Western tip of the island, Simonton Cove, Cuyler Harbor, and Cardwell Pt.

Trafficability: Good on sandy beaches

Cleanup Technique Code (3)

Access

Principal Entry Points: Potential access by boat at Southern side of Pt. Bennett in fair weather and at Cuyler Harbor

dangerous.

Inlets/Streams

Inlets: None

Streams: Intermittent creeks

Ownership and Control

Principal Property Owner(s): U.S. Government

Address:

Phone:

Controlling Government Authority: U.S. Navy

Waterfront Usage: Natural

Biological Data

Potential Threat to Wildlife: Marine Mammals and birds

Special Biological Significance: This island provides rookeries for five pinniped species and a haul-out area for a sixth. The west end is particularly important (Siva, 1976). The waters surrounding the island are of special biological significance, and the Coastal Commission recommends that offshore and onshore habitats be preserved in their present, relatively undisturbed, condition. The Santa Barbara Channel waters and islands are regarded by the Coastal Commission as a fragile resource area. Numerous points and reefs provide excellent habitats for aquatic species, and consequently a prime resource for fishermen. There are major fishing areas on Ventura Flats, immediately west of Goleta, and around the islands. San Miguel Island is presently inhabited by three rare and endangered species. The endangered species is the California Brown Pelican and the rare species are the Guadalupe Fur Seal and the Island Fox.

Seasonal Factors

Sand beaches can be expected to migrate on- and offshore seasonally.

Special Factors Affecting Spill Control

The convergence of ocean and channel currents at the easternmost tip of the island results in breakers and rough seas, making access or approach extremely dangerous.

Comments

Pinnipeds are very sensitive to human disturbance thus no onshore cleanup should be attempted near haul-out or rookery areas.

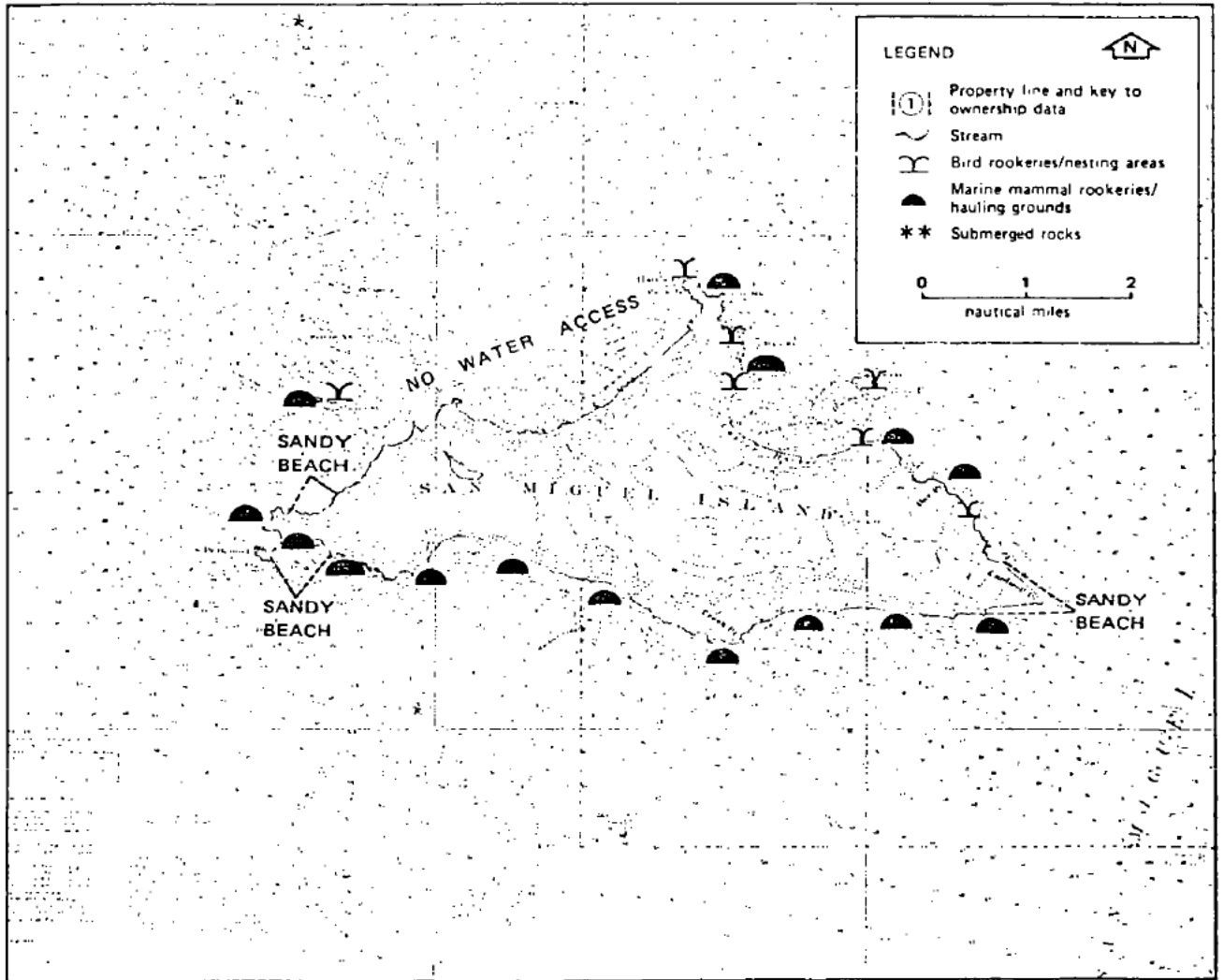

SAN MIGUEL ISLAND

SANTA ROSA ISLAND

Shoreline Characteristics

General Description: Predominantly steep or vertical cliffs falling directly into the water with occasional pocket sand/gravel beaches and/or rocky shoreline

Backshore:

Trafficability:

Cleanup Technique Code (3)

Access

Principal Entry Points: Landing is possible at most pocket beaches during fair weather

Boat Launching Facilities: Unknown

Inlets/Streams

Inlets: None

Streams: Numerous steep intermittent creeks

Ownership and Control

Principal Property Owner(s):

Address:

A. Yail
123 W. Padre St.
Santa Barbara, CA 93105

Phone:

Controlling Government Authority: Federal Government

Waterfront Usage: Sheep and cattle grazing on bluffs

Biological Data

Potential Threat to Wildlife: Birds and marine mammals

Special Biological Significance: Santa Rosa Island supports pinniped rookeries (Siva, 1976), and the waters surrounding it have been designated an area of special biological significance. Santa Rosa Island is inhabited by an endangered species, the California Brown Pelican and a rare species, the Island Fox. The island is also a hauling ground for Northern Elephant Seals, Harbor Seals, and California Sea Lions (Mate, 1977).

Seasonal Factors

Special Factors Affecting Spill Control

Extensive kelp beds off the northwestern tip of the Island can restrict access to adjacent shoreline.

Comments

Pinnipeds are very sensitive to human disturbance thus onshore cleanup should not be attempted near haul-out or rookery areas.

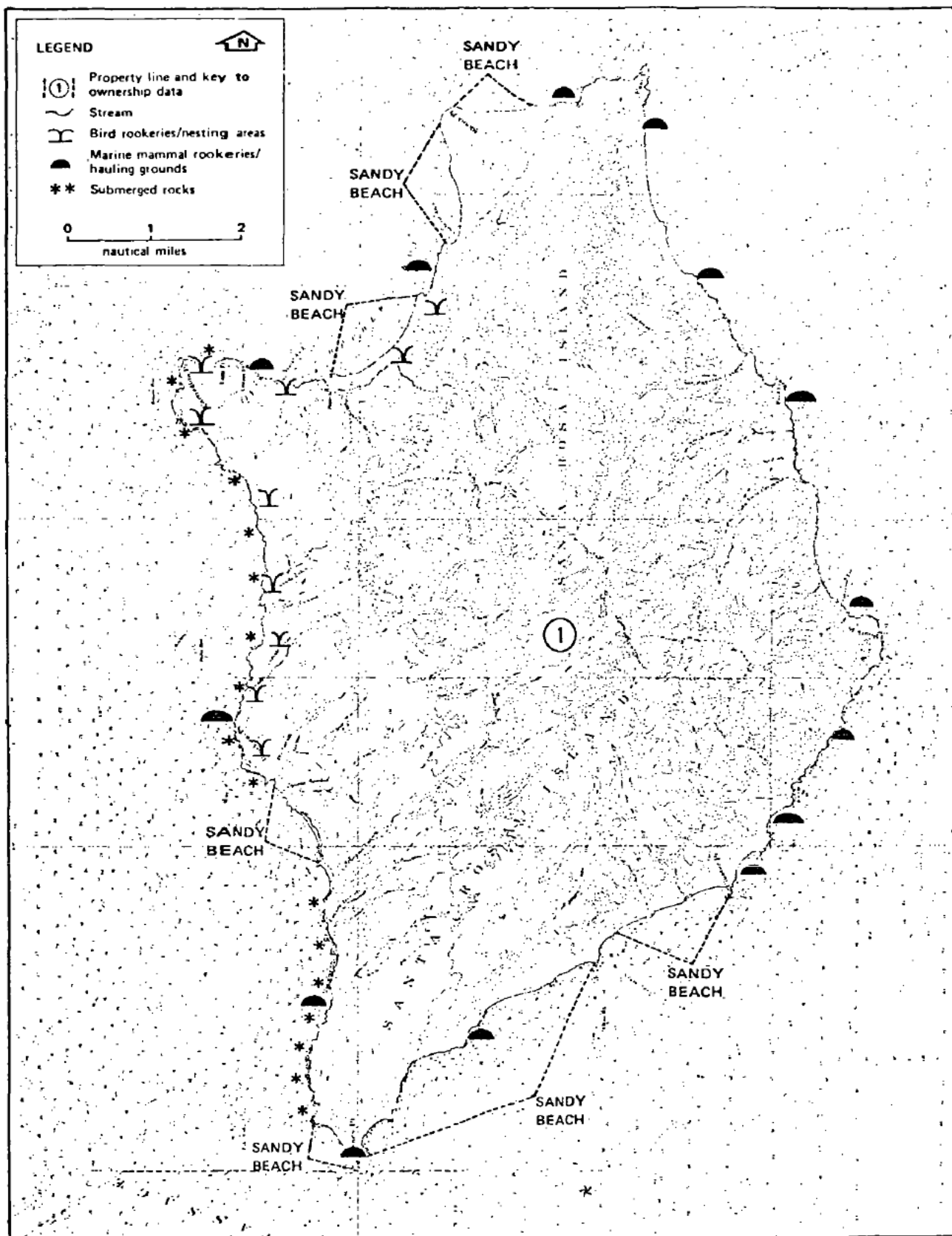

SANTA ROSA ISLAND

SANTA CRUZ ISLAND

Shoreline Characteristics

General Description: Predominantly steep or vertical cliffs falling directly into the water with occasional pocket sand/gravel beaches and rocky shoreline in the sheltered areas

Backshore:

Trafficability:

Cleanup Technique Code (3)

Access

Principal Entry Points: Access by boat at landings located at Scorpion Anchorage, Prisoner's Harbor and Willows Anchorage. There is also a roadway ending at Scorpion Anchorage.

Boat Launching Facilities: Scorpion and Willows anchorages and Prisoner's Harbor

Inlets/Streams

Inlets: None

Streams: Intermittent creeks

Ownership and Control

Principal Property Owner(s):

<u>Address:</u>	(1)	(2)
	Pier Gherini	Santa Cruz Island Company
	230 La Arcada Blvd.	Suite 1400
	Santa Barbara, CA 93104	615 S. Flower St.
		Los Angeles, CA 90017

Phone:

Controlling Government Authority: U.S. Government

Waterfront Usage: Cattle and sheep grazing on bluffs; natural

Biological Data

Potential Threat to Wildlife: Birds and marine mammals

Special Biological Significance: Santa Cruz Island supports seal and sea lion rookeries. The fauna of the intertidal zone is relatively undisturbed, and is biologically significant because the west end of the island intercepts the lower edge of the Santa Barbara Channel eddy (Siva, 1976). The waters surrounding the island have been designated an area of special biological significance. Santa Cruz Island supports habitats for three rare and endangered species. The endangered species is the California Brown Pelican and the rare species are the Guadalupe Fur Seal and the Island Fox. The island also supports rookeries and hauling grounds for Northern Elephant Seals, Harbor Seals, and California Sea Lions (Mate, 1977).

Seasonal Factors

Sand and gravel in pocket beaches will move on- and offshore seasonally.

Special Factors Affecting Spill Control

Currents off Fraser Point can be extremely dangerous.

Comments

Pinnipeds are very sensitive to human disturbance thus onshore cleanup should not be attempted near haul-out or rookery areas.

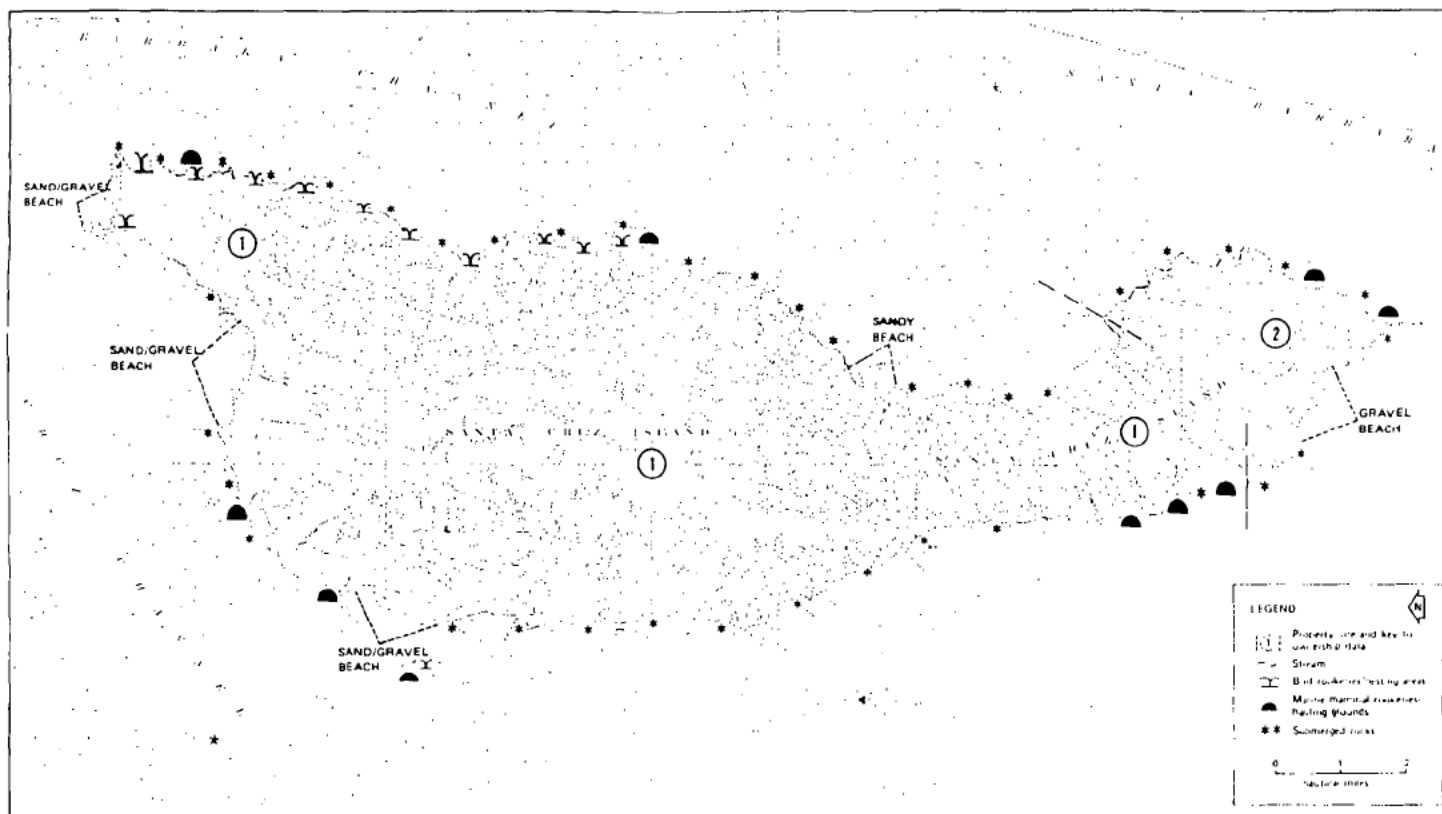

SANTA CRUZ ISLAND

ANACAPA

Shoreline Characteristics

General Description: Almost entirely vertical cliffs, terraces, and rocky shoreline with a few gravel pocket beaches

Backshore:

Trafficability:

Cleanup Technique Code (3)

Access

Principal Entry Points: Access by boat is possible at the Coast Guard landing on the north side near the eastern extremity. Other landings can be made on either side of the island near the west opening and at East Fish Camp.

Boat Launching Facilities: Coast Guard Landing

Inlets/Streams

Inlets: None

Streams: None

Ownership and Control

Principal Property Owner(s):

Address:

Channel Islands National Monument
1699 Anchors Way
Ventura, CA 93003

Phone:

Controlling Government Authority: U.S. National Park Service

Waterfront Usage: Limited recreation, diving, camping; mostly natural.

Biological Data

Potential threat to Wildlife: Birds, marine mammals, and intertidal communities

Special Biological Significance: The waters around the island are designated an area of special biological significance. Anacapa Island is inhabited by the California Brown Peican which is listed as an endangered species. The island also supports rookeries and hauling grounds for Northern Elephant Seals, Harbor Seals and California Sea Lions (Mate, 1977). In addition, Anacapa supports the richest tide pools in southern California.

Seasonal Factors

Special Factors Affecting Spill Control

Any disturbance of bird rookeries should be avoided. Helicopter landing is possible above Fish Camp and atop Middle and Eastern Islands.

Comments

Pinnipeds are very sensitive to human disturbance thus onshore cleanup should not be attempted near haul-out or rookery areas.

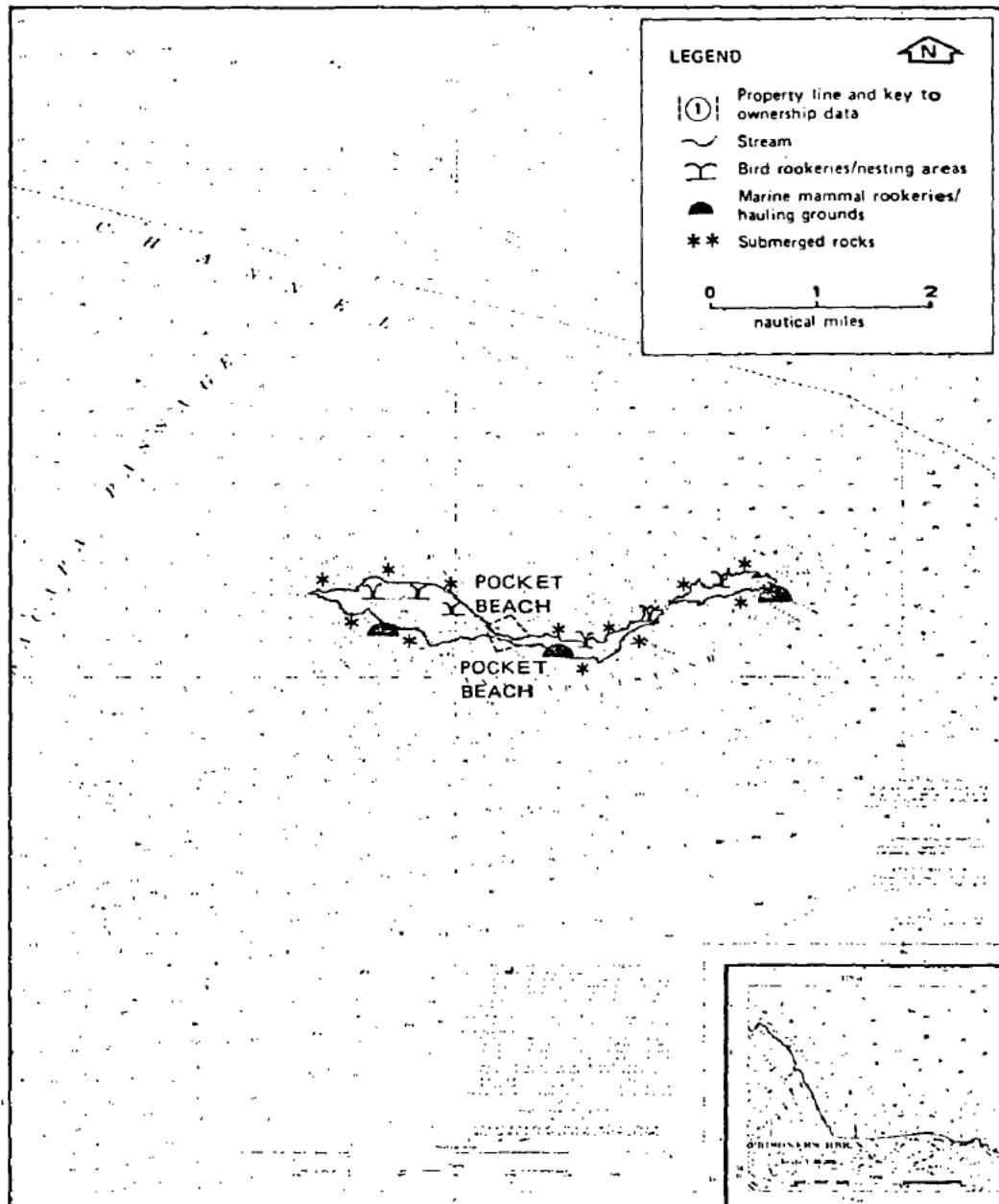

ANACAPA ISLAND

EXHIBITS

NUMBER	TITLE
I-A	Vicinity and Unit Map
I-B	Schedule of Activities
V-A	Typical Repetto Drilling Procedure and Well Design
V-B	Typical Monterey Drilling Procedure and Well Design
V-C	Diverter Arrangement Repetto Well
V-D	Blowout Preventer Arrangement 12,000' Rig
V-E	BOPE Pressure Requirement Calculations Repetto Producer
V-F	Diverter Arrangement Monterey Well
V-G	Blowout Preventer Arrangement 20,000' Rig
V-H	BOPE Pressure Requirement Calculations Monterey Producer
V-I	Blowout Preventer Arrangement 20,000' Rig
V-J	Blowout Pressure Requirement Calculations 20,000' Rig
VI-A	Platform - West Elevation
VI-B	Platform - South Elevation
VI-C	Drilling Deck Layout
VI-D	Production Deck Layout
VI-E	Sub-Deck Layout

NUMBER	TITLE
IX-A	Typical Gas Compressor Installation
IX-B	Simplified Flow Diagram
IX-C	Typical Installation of Safety Valves and Sensors
IX-D	Typical Installation of Pressure Vessels
IX-E	Typical Header Safety Devices
IX-F	Typical Pump Installation
XI-A	Pipeline Route Map
XII-A	Plot Plan of Onshore Site
XII-B	Artist's Conception of Plan View of Onshore Site
XII-C	Artist's Conception of Onshore Site Elevations-Existing
XII-D	Artist's Conception of Onshore Site Elevations-Proposed
XII-E	Piping and Instrumentation-Onshore Site
XVI-A	Proposed and Alternate Pipeline Routes

SECTION I

INTRODUCTION

The Santa Clara Unit, by virtue of the Santa Clara Unit Agreement approval, became effective March 31, 1973. The Unit is located in the southeast portion of the Santa Barbara Channel off the Ventura-Oxnard, California coast. It is comprised of the following eight leases: OCS P-0204, 0205, 0208, 0209, 0210, 0215, 0216, and 0217. See exhibit I-A.

In October, 1976, Chevron U.S.A. Inc., formerly Standard Oil of California, as operator for the Unit, submitted a Plan of Development for the north portion of the Santa Clara Unit on leases OCS P-0215, 0216, and 0217. After multiple amendments and modifications, this Plan of Development was approved on July 14, 1977. Subsequently, it was mutually agreed by Chevron and Union, and later sanctioned on August 3, 1979, by the U.S.G.S., that Union operate and develop separately its 100 percent working interest lease, OCS P-0216. Consequently, Chevron is the operator of the Unit, and Union has been designated agent for any and all operations conducted on lease OCS P-0216. Therefore, this Amended Plan of Development proposes operations necessary for the development of the Repetto and Monterey formations on OCS P-0216 by the Union Oil Company of California.

Union Oil Company of California's lease OCS P-0216, formerly tract 373, was acquired in a Federal lease sale in April, 1968, for a bonus of \$12,176,000. The lease contains 5869.6 acres and is located in Federal waters about eight miles off the coast in approximately 200 feet of water. The adjoining leases, OCS P-0217 on the west and P-0215 on the east, are held by Chevron U.S.A. Inc.

Platform Gilda, a proposed self-contained drilling and production platform, will be set in September, 1980, on OCS P-0216. The platform will contain conductor guides for 90 wells. Fifty have been designated for development of the Repetto reservoirs and thirty for development of the Monterey reservoir on OCS P-0216. The remaining ten well conductors on Platform Gilda will be available for use by Chevron for developing related Repetto and Monterey hydrocarbon accumulations on their adjacent lease to the east, OCS P-0215. To the west, Chevron's Platform Grace on OCS P-0217 will be used to develop reserves from Repetto and Monterey reservoirs on Chevron's lease which are separated structurally from oil and gas trapped on Union's lease OCS P-0216.

This Plan is a complete description of the proposed development project for lease OCS P-0216, and is the Amended Plan of Development to be submitted to the U.S.G.S. and other concerned agencies as described in OCS Order Nos. 8 and 11. It will, therefore, include the following: 1) a geotechnical review, 2) the field history and geology, 3) the reservoir descriptions, 4) the drilling procedures and facilities, 5) the platform structure and site, 6) the platform description and specifications, 7) the platform facilities, 8) a description of the production and power systems, 9) a description of the safety, antipollution, and control systems, 10) the pipeline system, 11) the onshore site, 12) the oil spill contingency plan, 13) the critical operations and curtailment plan, 14) a description of the circumstances under which critical drilling and production operations will be curtailed, 15) the alternatives available to the proposed plan, and 16) an appendix.

This Plan also describes the activities necessary to complete: 1) fabrication and installation of a drilling and production platform in 210 feet of water, 2) fabrication and installation of the facilities on said platform necessary to test, measure, and transport the production, and to measure and inject produced water, 3) installation of two drilling rigs with associated facilities, 4) installation of an oil pipeline and gas pipeline to shore, and a return pipeline for produced water, 5) installation of onshore facilities necessary to receive, heat, separate, measure, and distribute the production, and 6) installation of safety controls and pollution prevention facilities necessary to protect operating equipment and the environment.

The development will be in accordance with the schedule of activities given in exhibit I-B.

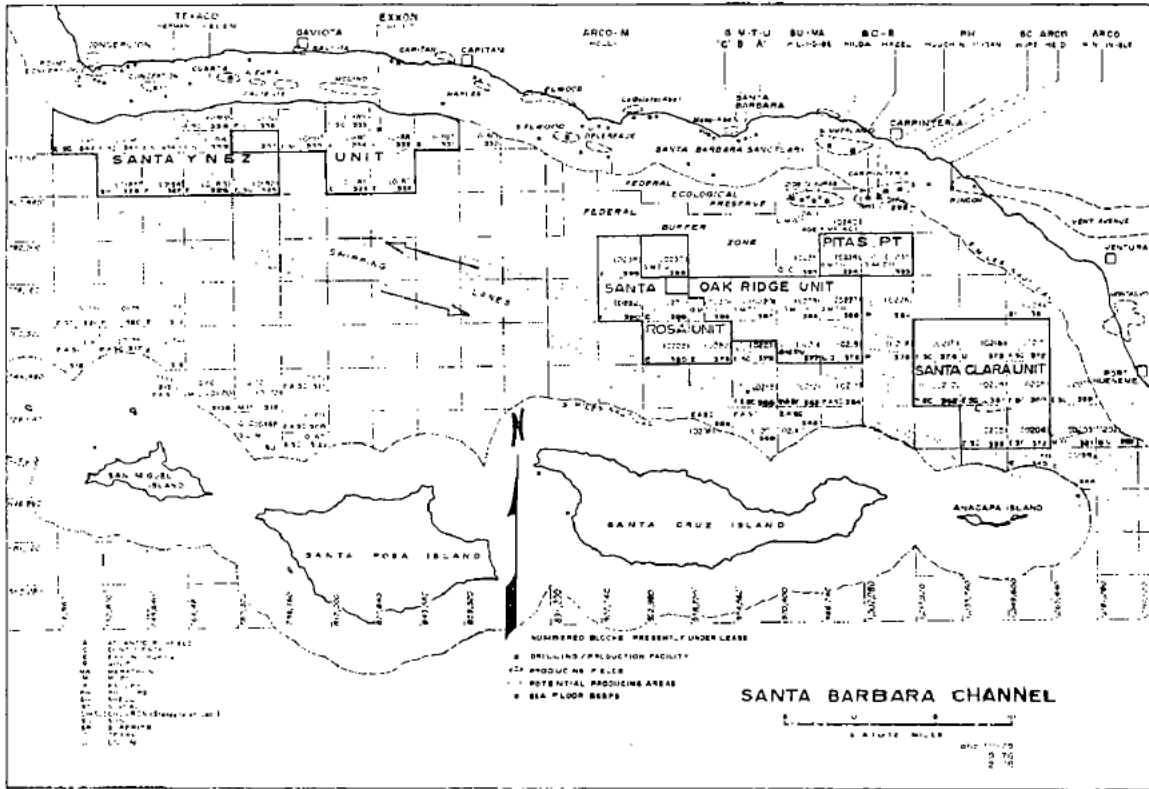

EXHIBIT I-A

SANTA CLARA DEVELOPMENT
PLATFORM GILDA

		1978		1979						1980						1981	1982	1983	1984	1985
		S-O	N-D	J-F	M-A	M-J	J-A	S-O	N-D	J-F	M-A	M-J	J-A	S-O	N-D	J-D	J-D	J-D	J-D	J-D
ONSHORE SITE	ENGINEERING						██████████													
	ORDER MATERIAL							██████████	██████████	██████████	██████████	██████████	██████████	██████████						
	CONSTRUCTION											██████████	██████████	██████████						
PERMITS	U.S.G.S.						██████████	██████████	██████████	██████████	██████████	██████████	██████████							
	COASTAL ZONE MNGT.						██████████	██████████	██████████	██████████	██████████	██████████	██████████							
	CORPS OF ENGINEERS						██████████	██████████	██████████	██████████	██████████	██████████	██████████							
	U.S.G.S. (ROW.)						██████████	██████████	██████████	██████████	██████████	██████████	██████████							
	STATE LANDS (ROW.)						██████████	██████████	██████████	██████████	██████████	██████████	██████████							
	E.I.R./E.A. COASTAL COMM.						██████████	██████████	██████████	██████████	██████████	██████████	██████████							
SUPPORT	POWER CABLE-ELEQUIP.						██████████	██████████	██████████	██████████	██████████	██████████	██████████							
	ENGINEERING						██████████	██████████	██████████	██████████	██████████	██████████	██████████							
	ORDER MATERIAL							██████████	██████████	██████████	██████████	██████████	██████████							
	INSTALL PIPELINE												██████████							
PLATFORM	ENGINEERING						██████████	██████████	██████████	██████████	██████████	██████████	██████████							
	ORDER MATERIAL												██████████							
	FABRICATION													██████████						
	TRANSPORATION														██████████					
	ERECTION															██████████				
	ORDER RIG, RIG UP																██████████			
	FACILITIES ENGINEERING																			
	ORDER MATERIAL																			
INSTALL																				
DRILL 1 WELL																				
DRILL 16 WELLS																				
DRILL 24 WELLS																				
DRILL 19 WELLS																				
DRILL 16 WELLS																				
DRILL 4 WELLS																				

SECTION II

GEOTECHNICAL REVIEW

The approved Plan of Development, Santa Clara Unit, OCS leases P-0215, P-0216, and P-0217, submitted by Chevron U.S.A. dated October, 1976, thoroughly discussed the regional and area geotechnical conditions of the Santa Clara Unit. The platform location, X = 1,041,760 and Y = 747,980, proposed by Union on OCS P-0216 and a portion of the pipeline route have been examined in terms of sea floor and shallow subsea floor hazards. Basis of this evaluation was a December, 1974, high resolution geophysical survey conducted by Aquatronics, and the resulting interpretations. This survey incorporated a dual 1.5 K joule sparker, an echo sounder, side scan sonar, and 3.5 KHz sub-bottom profiler. Interpretation of data obtained indicates that there will be no problems with respect to sea bottom slope or unconsolidated surface sediments (20 feet). The proposed site location lies in an area with a gently sloping seabed (80 feet per mile) with no evidence of seafloor irregularities, mounds, or gas seeps in the immediate vicinity of the proposed site. Additionally, no evidence of any cultural resources was defined by side scanning sonar, microprofiler or fathometer surveys. These surveys also showed that the proposed pipeline route from the platform location to the eastern boundary of OCS P-0216 has no anomalies on the surface of the gently sloping seabed.

Examination of sparker data does indicate that some evidence of reflection amplitude increases in the site area. The amplitude increases are seen at calculated depths of 400' and 1150', respectively. The amplitude

increases are of a similar nature to an increase over the site of Union's OCS P-0216 No. 2 well. This well encountered no significant shallow gas occurrences and experienced no drilling problems in this section.

The proposed hazard survey for the platform site will be of superior quality with a closer grid density and should more than adequately define these amplitude increases and assess their potential for a platform setting problem. Presently available data indicate that the platform location and the portion of the pipeline route are clear of any substantial hazards or risks.

The seabed at the Platform Gilda site is a thick deposit of silt similar to other locations sampled in the Santa Clara Unit. The soil at this site should provide an excellent foundation for the platform. Tests made to date on soil samples from the location show these soils capable of carrying the foundation pile loads with no tendency to liquify under expected earthquake loading.

The static and dynamic foundation soil testing program is well under way by Fugro, Inc., Long Beach. Two soil borings were taken at the proposed platform site in early July, 1979. Generally, the material found in the borings is a uniform, normally consolidated silt, containing traces of mica particles and fine sand. Tectonic studies and engineering assessments will determine the foundation soils' load-carrying capacity

under both static and earthquake loads. From these studies, the probable level of earthquake shaking for the strength level platform design will be determined.

SECTION III

GEOLOGY AND FIELD HISTORY

The Santa Clara field lies on the Oakridge structural trend and is a multi-reservoir, commercial accumulation of oil and gas. The ages of the productive reservoirs are Pliocene and Miocene. Within the area of leases OCS P-0215, P-0216, and P-0217, the structure is a faulted anticline and trends in an east-west direction. This generally east-west-trending anticlinal structure is bounded on the south by a high-angle reverse fault.

There are structural lows, or saddles, and faults interrupting the continuity of the hydrocarbon concentrations along the general trend, and particularly in the area of leases OCS P-0215, P-0216, and P-0217. Saddles are structural features created by the sagging of an anticline. Faults, another type of structural feature, are fractures or a fracture zone along which there has been displacement of the two sides relative to one another parallel to the fracture. These saddles and faults have combined to form structural traps which separate hydrocarbon accumulations on one lease from similar accumulations on the other leases. Also, there are stratigraphic changes existing within the geologic strata encompassed by these leases which likewise effect traps and isolate the hard-to-find pools of oil and gas.

The Repetto formation of Pliocene age contains several oil-bearing intervals. The upper interval, LP-B, between the LP-B and LP-B₁ markers, has produced crude; the lower interval, LP-C, between the LP-B₁ and LP-D markers, has also produced crude. These markers are discussed further in Section IV.

The fractured Monterey shale of Miocene age has tested measurable quantities of varying gravity crude oils and gas. No significant pattern of reservoir quality or productive extent has been determined for the Monterey on OCS P-0216.

Hydrocarbons were first discovered in February, 1971, by Union OCS P-0216 No. 1. Extensive testing produced oil and gas from the lower Repetto formation of lower Pliocene age. Chevron (formerly Standard Oil Company of California) drilled OCS P-0215 No. 1 in 1973, discovering Miocene Monterey formation oil producible at favorable rates. Chevron drilled OCS P-0217 Nos. 1 and 2 in 1975, which established oil reserves in the Repetto and Monterey formations. Chevron is currently developing these reserves on OCS P-0217 with Platform Grace.

Flanked by these successful exploratory wells, Union drilled OCS P-0216 No. 2 in 1976. This well tested oil and gas from the Monterey at encouraging rates, and well logs indicated the Repetto formation to have hydrocarbons present. All attempts to test the Repetto in this well were unsuccessful, however, and Union drilled OCS P-0216 Nos. 3 and 4 in 1978-1979 to test and delineate the extent of the Repetto hydrocarbon accumulation. These wells proved the presence of a significant Repetto oil field on Union's lease OCS P-0216.

A redrill of well no. 3, OCS P-0216 No. 3 RD 1, revealed the inconsistency of the Monterey reservoir when it tested low gravity crude oil at low rates from the Monterey formation. This inconsistency was confirmed by Chevron's OCS P-0215 No. 2 which also produced low gravity crude at a low rate.

SECTION IV

RESERVOIR DESCRIPTION

For the purpose of readily identifying and relating specific stratigraphic intervals from one well to another, the upper Repetto formation was subdivided on the basis of easily recognizable electric log (e-log) characteristics. These correlative e-log markers were named and now represent the basic scheme of nomenclature used for identification.

Exploratory wells tested sands of the upper Repetto formation within two distinct segments of sedimentary rock between e-log marker LP-B and LP-D. For this reservoir evaluation portion of the Plan, section IV, the shallower test segment is referred to as the LP-B interval with its top defined by the LP-B e-log marker and its base by the LP-B₁ e-log marker. The second and slightly deeper test segment is called the LP-C interval. Its boundaries are the LP-B₁ marker at the top and the LP-D marker for the base.

In order to optimize the development of these Repetto reservoirs, Intercomp's Beta II black oil model was used to simulate various development schemes. From this model study the following conclusions were reached:

1. Under solution gas drive, 40 producers on approximately 20-acre spacing would produce the oil reservoirs in 20 years from the LP-B and LP-C intervals if each well produced at a sufficient rate.

2. Additional oil could be recovered from both intervals by these wells if the produced water is injected in a peripheral pattern.
3. Additional production and injection data will be required before full pressure maintenance can be initiated.

The production schedule produced by the simulator for the optimum producing scheme assumed that 40 producers and 10 injectors on 20-acre spacing would be drilled. The injectors, for injection of all of the produced water, would be drilled as needed. Wells would be drilled at the rate of two per month.

Initial development wells will be drilled on approximately 40-acre spacing with the earliest wells designed to acquire additional structural-geologic information and reservoir production data. After defining the reservoir, infield wells on 20-acre spacing will be drilled. Injection wells will be drilled to return the produced water to the formation. Injection and production performance will be closely monitored and the results analyzed. Additional water injection schemes will be simulated after observing early field performance.

Because of the unconsolidated nature of the Repetto sands, gravel-packed completions will be necessary for both injectors and producers. The gravel-packs will cover all the Repetto intervals, and all production from the Repetto will be commingled within each well.

The Monterey formation of Middle and Upper Miocene is the secondary objective on OCS P-0216. This formation is age equivalent and deposi-

tionally analogous to the Cat Canyon field near Santa Maria, California. As such, data from the Cat Canyon field was used in the analysis of the Monterey on OCS P-0216.

Development of the Monterey formation is currently planned to commence near the end of the 50-well Repetto program. The first well would be drilled to an upstructure location near OCS P-0216 No. 2. The production characteristics of the Monterey on OCS P-0216 are not predictable, nor is the oil gravity. Therefore, a conservative development program is planned, and it involves moving one 40-acre location at a time away from the proven productive area. It is anticipated that additional information about the producing characteristics of the Monterey formation will be obtained from OCS P-0217 development and will be available well in advance of the initiation of drilling as proposed in this Plan. Consequently, the development scheme for the Monterey may be expedited and modified in order to achieve maximum recovery from this formation.

SECTION V

DRILLING

Two drilling rigs will be utilized to drill the wells. One of the rigs will be rated at 1,000 horsepower and capable of drilling to 12,000' M.D. using 4 1/2" drill pipe. The other rig will be rated at 2,000 horsepower and be capable of drilling to 20,000' M.D. with 4 1/2" drill pipe. These rigs will be especially designed and/or adapted for use on offshore platforms. The 12,000' M.D. capacity drilling rig will be purchased by Union and maintained on the platform for subsequent use. The 20,000' M.D. capacity drilling rig will be obtained from a contract rig owner and removed from the platform at the end of the drilling program. The crews necessary to operate both rigs will be supplied by contract drilling companies. The rig components will be designed for mobilization and demobilization using the platform cranes. The masts will be designed in accordance with API standard 4D for freestanding masts.

A skid beam and transverse skid base will be provided to support the rig substructure. The skid beam/transverse skid base system will be equipped with hydraulic jacks and will be capable of moving the drilling rigs over the various well locations in the wellhead rooms.

A separate mud system will be provided for each rig. Two 1,000 H.P. mud pumps will be provided for each rig along with a surge tank, mixing pump

and hopper. The smaller rig will have an active mud tank of 400 barrels working capacity and a mud storage tank of 300 barrels working capacity. The larger rig will have an active mud tank of 500 barrels working capacity and a mud storage tank of 500 barrels working capacity. Weight of the mud for structural design purposes is assumed to be 18 lb./gallon. The storage tanks will be interconnected for emergency use, but will normally be separated by closed valves in the interconnecting piping. Each mud tank will be equipped with agitation equipment and transfer pumps.

Return mud will be treated with separate high-speed, dual-screen shale shakers, desanders, desilters, degassers and a cuttings washing system.

Mud volumes will be closely monitored using a pit volume totalizer system; an incremental flowrate indicator; a pit level indicator; and a fill-up measurement system. These systems will be equipped with sensors to provide for visual monitoring and audible alarms near the driller's console.

One diesel-powered dual cementing unit and three 1,000 cu. ft. bulk storage tanks will be provided for well cementing and well completion operations.

Power for the operation of the rigs will be supplied from a public utility using an offshore marine combination power transmission and communication cable, transformers, and SCR units. This method of powering the rigs has been determined to have the least environmental

impact and is discussed more fully in section XVI and in the accompanying Environmental Report. Since the larger power loads resulting from drilling operations last a relatively short time, public utility power will result in significant economies of operation as compared to alternate power sources.

The drilling procedures and well designs shown on exhibits V-A and V-B, are in accordance with approved Field Rules for adjacent block OCS P-0217. A copy of those Field Rules is included in appendix A for reference. Blowout prevention equipment will be installed and maintained ready for use on all casing strings as prescribed in OCS Orders. Calculations of maximum pressure to be contained by each BOP stack are given in the exhibits. A separate blowout prevention system will be in use on each rig as follows:

12,000' rig: (Repetto Wells) Before drilling below the 20" conductor casing, a 500 psi working pressure diversion system will be installed in accordance with OCS Order No. 2, section 2-B. The diverter system will be equipped, as shown in exhibit V-C, with automatic, remotely-controlled valves designed to open prior to shutting in the well.

Before drilling below the 16" surface casing, the blowout prevention system will include four remotely controlled, hydraulically operated blowout preventors, including two equipped with pipe rams, one with blind rams, and one annular-type blowout preventer, as shown in exhibit V-C. The blowout preventer and riser assembly will have a rated working pressure of 3000 psi which exceeds the maximum anticipated surface pressure, as calculated in exhibit V-E.

20,000' rig: (Repetto and Monterey Wells) Before drilling below the 24" conductor casing, a 500 psi working pressure diversion system will be installed in accordance with OCS Order No. 2, section 2-B. The diverter system will be equipped, as shown in exhibit V-F, with automatic, remotely controlled valves designed to open prior to shutting in the well.

Before drilling below the 20" surface casing, the blowout prevention system will include three remotely controlled, hydraulically operated blowout preventers, including one pipe ram and one blind ram, and one annular-type blowout preventer, as shown in exhibit V-G. The blowout preventer and riser assembly will have a rated working pressure of 2000 psi, which exceeds the maximum anticipated surface pressure, as calculated in exhibit V-H.

Before drilling below the 13-3/8" intermediate casing, the blowout prevention system will include four remotely controlled, hydraulically operated blowout preventers, including two equipped with pipe rams, one with blind rams, and one annular-type blowout preventer, as shown in exhibit V-I. The blowout preventer and riser assembly will have a rated working pressure of 5000 psi, which exceeds the maximum anticipated surface pressure, as calculated in exhibit V-J.

Both blowout prevention systems will be equipped with the following:

1. A hydraulic actuating system that provides sufficient accumulator capacity to repeatedly operate the blowout preventers.
2. If side outlets are not provided in the blowout preventer body, a drilling spool with side outlets will be installed to provide for kill and choke lines.

3. Choke and kill lines, choke manifold, and fill-up line.
4. A top kelly cock installed below the swivel and another at the bottom of the kelly of such design that it can be run through the blowout preventers.
5. An inside blowout preventer and a full opening drill string safety valve in the open position shall be maintained on the rig floor at all times while drilling operations are being conducted. The valves will be maintained on the rig floor to fit all connections in the drill string.

The blowout prevention system will be pressure tested when the equipment is installed, before drilling out after each string of casing is set, not less than once each week while conducting drilling operations, and following repairs that require disconnecting a pressure seal in the assembly. All pressure tests will be in accordance with OCS Orders.

EXHIBIT V-A

SANTA CLARA UNIT

TYPICAL REPETTO WELL
PROCEDURE

1. Rig up.
2. Drill 26" hole to 500' VD (200' BOF).
3. Run and cement 20" casing 200' BOF. Install diverter.
4. Directionally drill 17-1/2" hole to 1300' VD (1000' BOF). Underream hole to 22".
5. Run and cement 16" casing 1000' BOF. Install and test 3000 psi BOPE.
6. Directionally drill 15" hole to 3800' VD (3500' BOF).
7. Run and cement 10-3/4" casing 3500' BOF.
8. Directionally drill 9-7/8" hole to 6700' TMD, 5940' TVD.
9. Run logs.
10. Underream Repetto interval to 15" from 6200' to 6700'.
11. Run Caliper log.
12. Run 7" combination blank and slotted 20-mesh wire-wrapped casing to 6680'.
13. Gravel pack Repetto interval.
14. Cement blank section above gravel-packed interval.
15. Run completion equipment on 2-7/8" tubing.
16. Remove BOPE and install Christmas tree.

WATER DEPTH 210'
 RT TO MLLW 90'
 RT TO ML 300'

20" 94# C 500' VD
 (200' BOF)

16" 75# C 1300' VD
 (1000' BOF)

10-3/4", 40.5# C 3800' VD
 (3500' BOF)

Top Repetto 6200' MD

7" Port Collar
 7" Lynes Packer
 7" Port Collar

9-7/8" hole opened to 15" 6200'-6700'
 20-M wire-wrapped casing 6200'-6680'
 Gravel packed with 10-20 mesh gravel.

7" 26# I. 6680'
 6700' IMD
 5940' TVD
 5640' TVD BML

EXHIBIT V-A CONT'D.

REV.	DATE

SANTA CLARA FIELD
 SANTA BARBARA CHANNEL
 UNION-OCS P-0216
TYPICAL WELL SCHEMATIC
REPETTO WELL

UNION OIL COMPANY OF CALIFORNIA

DRAWN J.F. CKD.
 APPD.
 SCALE NONE
 DATE 10-79

SHEETS / SHEET

EXHIBIT V-B

SANTA CLARA UNIT

TYPICAL MONTEREY PRODUCER
PROCEDURE

1. Rig up.
2. Drill 30" hole to 600' VD (300' BOF).
3. Run and cement 24" casing 300' BOF. Install diverter.
4. Directionally drill 17-1/2" hole to 1800' VD (1500' BOF). Underream to 26".
5. Run and cement 20" casing 1500' BOF. Install and test 2000 psi BOPE.
6. Directionally drill 18-5/8" hole to 4800' VD (4500' BOF). Run logs.
7. Run and cement 13-3/8" casing 4500' BOF. Remove 2000 psi BOPE and install 5000 psi BOPE.
8. Directionally drill 12-1/4" hole to 8700' MD. (7000'± BOF) Run logs.
9. Run and cement 9-5/8" casing at 7000'± BOF.
10. Directionally drill 8-1/2" hole to 9700' MD, 8800' TVD. Run logs.
11. Run and cement 7" liner from 9700' to 8400'.
12. Run cement bond log.
13. Perforate Monterey interval.
14. Run completion equipment on 2-7/8" tubing.
15. Remove BOPE and install Christmas tree.

WATER DEPTH	210'
RT TO MLLW	90'
RT TO ML	300'

24" C 600' VD
(300' BOF)

20" 94# C 1800' VD
(1500' BOF)

13-5/8", 72# C 4800' VD
(4500' BOF)

9-5/8", 47# C 8700' MD

Top Monterey 8700' MD

7", 26# C 9700'

9700' TMD
8800' TVD
8500' TVD BML

EXHIBIT V-B CONT'D.

REV.	DATE

SANTA CLARA FIELD
SANTA BARBARA CHANNEL
UNION-OCS P-0216
TYPICAL WELL SCHEMATIC
MONTEREY WELL

UNION OIL COMPANY OF CALIFORNIA

DRAWN	J.F.	CKD.	
APP'D.			
SCALE	NONE		
DATE	10-79		

SHEETS | SHEET

12" FLOW LINE
(TO SHAKERS)

AUTOMATIC VALVES

12"
DIVERTER
LINE

12"
DIVERTER
LINE

DIVERTER

RISER
CONNECTOR

20"
RISER

ADAPTER

20"
CASING
(CMT'D
200'
BOF)

EXHIBIT V-C

REV.	DATE

DIVERTER ARRANGEMENT

500 PSI WORKING PRESSURE
REPETTO WELL

DRAWN J.F. CKD. _____
APP'D. _____
SCALE NONE
DATE 10-79

UNION OIL COMPANY OF CALIFORNIA

SHEETS | SHEET

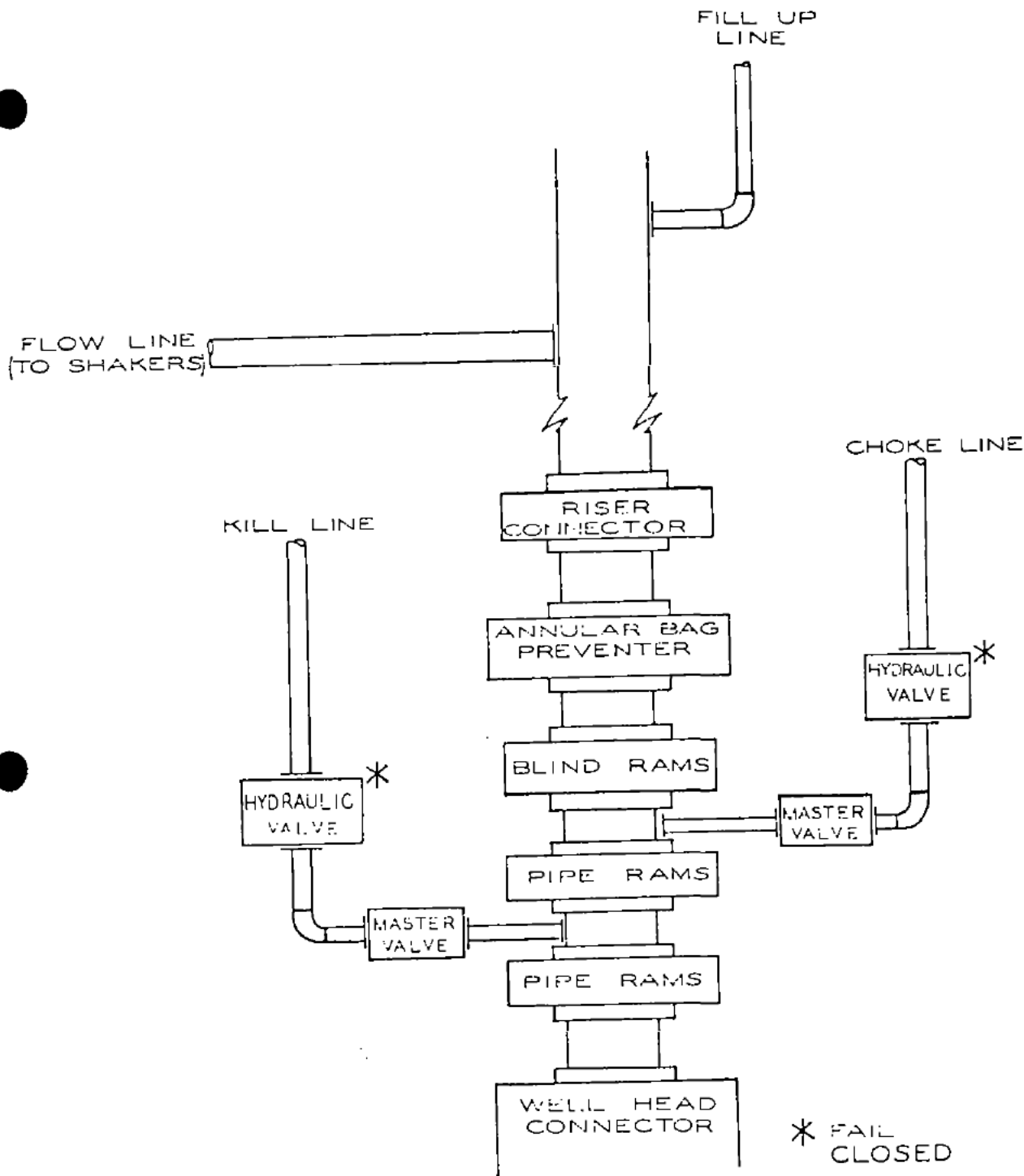

EXHIBIT V-D

REV.	DATE

**BLOWOUT PREVENTER
ARRANGEMENT**
3,000 PSI WORKING PRESSURE
12,000' RIG

UNION OIL COMPANY OF CALIFORNIA

DRAWN J.F. CKD.
APPD. _____
SCALE NONE
DATE 10-79

SHEETS 1 SHEET

EXHIBIT V-E

SANTA CLARA UNIT
PLATFORM GILDA

BOPE PRESSURE REQUIREMENTS - REPETTO PRODUCER

Calculation of Maximum Pressure to be Contained by BOP Stack:

While drilling at 5640' BOF (5940' VD), T.D.

- (1) Theoretical maximum surface pressure = shut-in formation pressure of 3250 psi based on drill stem test data compiled from drilling on OCS P-0215, P-0216, and P-0217.

If correction is made for weight of gas column:

$$\text{Surface Pressure} = \frac{3250 \text{ psi}}{e^{.0000347 \times .67 \times 5940}} = \underline{2831 \text{ psi}}$$

- (2) Anticipated maximum possible based on fracture pressure at shoe of last casing string (10-3/4") set at 3500' BOF (3800' VD, 3700' VD below MLLW).

$$3700' \times 0.76 \text{ psi/ft}^* = \underline{2812 \text{ psi}}$$

* Estimated from formation leakoff tests in OCS P-0216 #3.

If correction is made for weight of gas column:

$$\text{Surface pressure} = \frac{2812 \text{ psi}}{e^{.0000347 \times .65 \times 3800}} = \underline{2581 \text{ psi}}$$

- (3) Compare (1) and (2) corrected for weight of gas column with rated working pressure of BOPE = 3000 psi - rams
3000 psi - annular

12" FLOW LINE
(TO SHAKERS)

AUTOMATIC VALVES

12"
DIVERTER
LINE

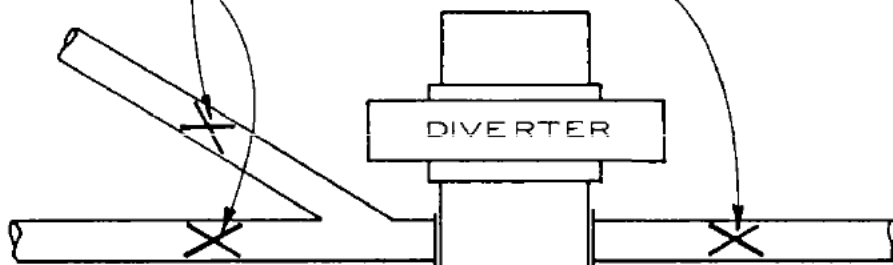

12"
DIVERTER
LINE

DIVERTER

RISER
CONNECTOR

20"
RISER

ADAPTER

24"
CASING
(CMT'D
300'
BOF)

EXHIBIT V-F

REV.	DATE

DIVERTER ARRANGEMENT 500 PSI WORKING PRESSURE MONTEREY WELL

UNION OIL COMPANY OF CALIFORNIA

DRAWN J. F. CKD.
APP'D. _____
SCALE NONE
DATE 10-79

SHEETS | SHEET

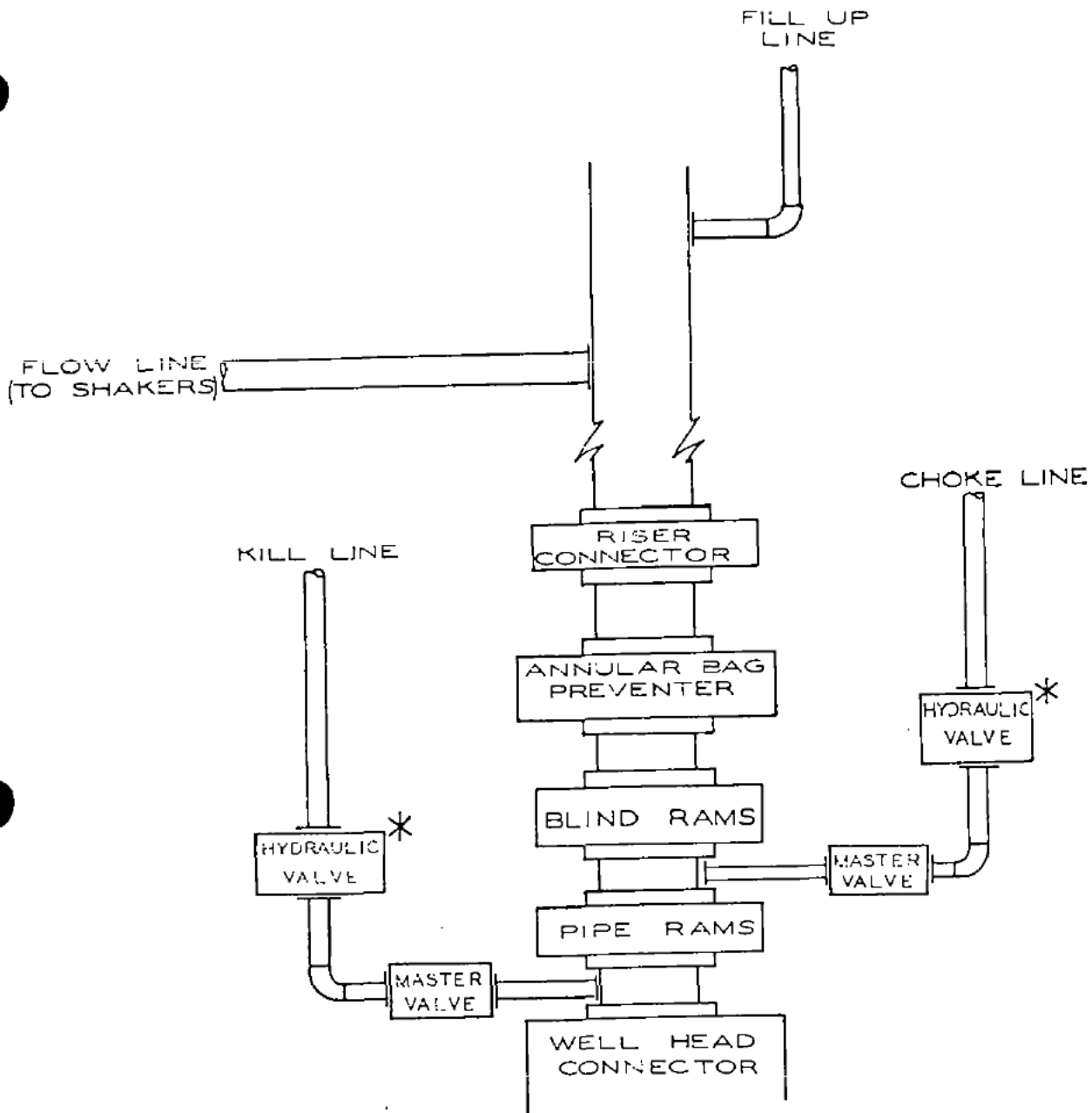

* FAIL CLOSED

EXHIBIT V-G

REV.	DATE

BLOWOUT PREVENTER
ARRANGEMENT
2,000 PSI WORKING PRESSURE
20,000' RIG

UNION OIL COMPANY OF CALIFORNIA

DRAWN J.F. CKD.
APPD. _____
SCALE NONE
DATE 10-79

SHEETS / SHEET

EXHIBIT V-H

SANTA CLARA UNIT
PLATFORM GILDA

BOPE PRESSURE REQUIREMENTS - MONTEREY PRODUCER

Calculation of Maximum Pressure to be Contained by BOP Stack:

While drilling at 4500' BOF (4800' VD) - 13-3/8" casing point

- (1) Theoretical maximum surface pressure = estimated shut-in formation pressure:

$$4800' \times 0.514 \text{ psi/ft}^* = \underline{2467 \text{ psi}}$$

*gradient of maximum anticipated mud weight (74 pcf)

If correction is made for weight of gas column:

$$\text{Surface Pressure} = \frac{2467 \text{ psi}}{e^{.0000347 \times .65 \times 4800}} = \underline{2214 \text{ psi}}$$

- (2) Anticipated maximum pressure possible based on fracture pressure at shoe of last casing string (20") set at 1500' BOF (1800' VD, 1700' below MLLW).

$$1700' \times 0.78 \text{ psi/ft}^* = \underline{1326 \text{ psi}}$$

*Estimated from formation leakoff test in OCS P-0216 #3.

- (3) Compare (2), the controlling factor in this case with rated working pressure of BOPE = 2000 psi - rams
2000 psi - annular

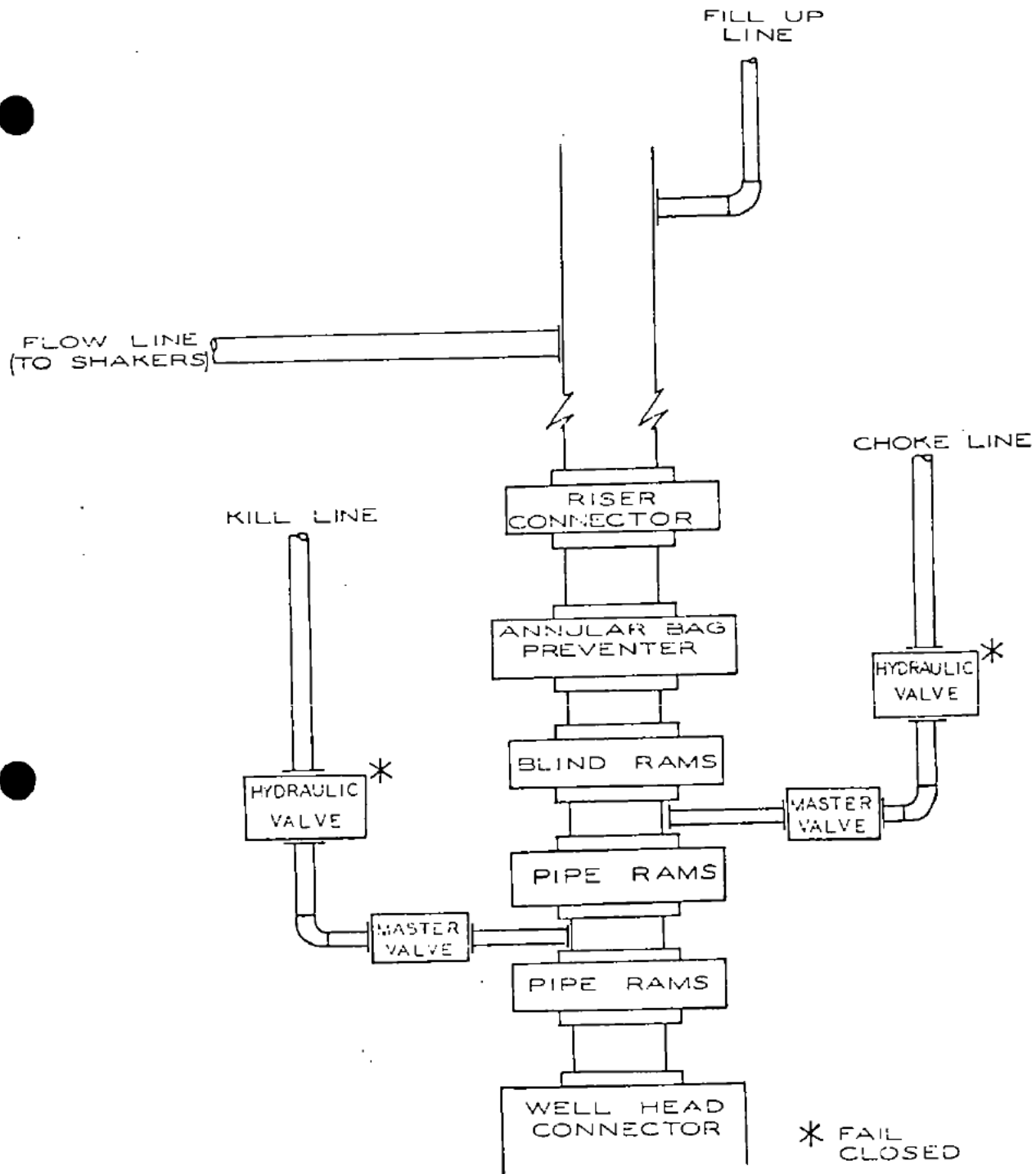

EXHIBIT V-I

REV.	DATE

BLOWOUT PREVENTER
ARRANGEMENT
5,000 PSI WORKING PRESSURE
20,000' RIG

UNION OIL COMPANY OF CALIFORNIA

DRAWN	_____	CKD.	_____
APP'D.	_____	SCALE	NONE
DATE	10-79		

SHEETS | SHEET

EXHIBIT V-J

SANTA CLARA UNIT
PLATFORM GILDA

BOPE PRESSURE REQUIREMENTS - MONTEREY PRODUCER

Calculation of Maximum Pressure to be Contained by BOP Stack:

- (a) While drilling at 7000' BOF (7300' VD)
9-5/8" casing point at top Monterey

- (1) Theoretical maximum surface pressure = estimated shut-in formation pressure:

$$7300' \times 0.729 \text{ psi/ft}^* = \underline{5322 \text{ psi}}$$

* gradient of maximum anticipated mud wt. (105 pcf)
(OCS P-0216 #3 mud wt. at this depth was 103 pcf.)

If correction is made for weight of gas column:

$$\text{Surface pressure} = \frac{5322 \text{ psi}}{e^{.0000347 \times .65 \times 7300}} = \underline{4514 \text{ psi}}$$

- (2) Anticipated maximum pressure possible based on fracture pressure at shoe of last casing string (13-3/8") set at 4500' BOF (4800' VD, 4700' below MLLW).

$$4700' \times 0.790 \text{ psi/ft}^* = \underline{3713 \text{ psi}}$$

* Estimated from formation leakoff tests in OCS P-0216 #2 and #3.

If correction is made for weight of gas column:

$$\text{Surface Pressure} = \frac{3713 \text{ psi}}{e^{.0000347 \times .65 \times 4800}} = \underline{3332 \text{ psi}}$$

- (3) Compare (1) and (2) corrected for weight of gas column with rated working pressure of BOPE = 5000 psi - rams
5000 psi - annular

EXHIBIT V-J (CONT'D)

(b) While drilling at 8500' TVD BOF (8800' VD)

- (1) Theoretical maximum surface pressure = shut-in formation pressure of 3880 psi, based on drill stem test data compiled from drilling on OCS P-0209, P-0215, P-0216 and P-0217.

If correction is made for weight of gas column:

$$\text{Surface Pressure} = \frac{3880 \text{ psi}}{e^{.0000347 \times .65 \times 8800}} = \underline{3181 \text{ psi}}$$

- (2) Anticipated maximum pressure possible based on fracture pressure at shoe of last casing string (9-5/8") set at 7000' BOF (7300' VD, 7200' below MLLW).

$$7200' \times 0.79 \text{ psi/ft}^* = \underline{5688 \text{ psi}}$$

*Estimated from formation leakoff tests in OCS P-0216 #2 and #4.

If correction is made for weight of gas column:

$$\text{Surface pressure} = \frac{5688 \text{ psi}}{e^{.0000347 \times .65 \times 7300}} = \underline{4825 \text{ psi}}$$

- (3) Compare (1) and (2) corrected for weight of gas column with rated working pressure of BOPE = 5000 psi - rams
5000 psi - annular

SECTION VI

PLATFORM STRUCTURE AND SITE

Platform Gilda will be a 12-leg template-type structure installed in 210 feet of water at Lambert coordinates X = 1,041,760 and Y = 747,980 (California Lambert Grid Zone VI).

The structure will be designed to meet or exceed the latest OCS Orders for the most severe loads that might occur during all phases of transportation, installation, and subsequent operations. Design considerations will also take into account severe wind and wave conditions. Seismic design of the platform will follow the guidelines set forth in API RP2A par. 2.10 and will include Zone 4 seismic criteria applied to a three-dimensional analytical model using the response spectrum method. The analysis will be done under the supervision of a registered civil engineer well acquainted with the techniques involved in earthquake resistant design of offshore structures.

To assure compliance with the OCS Orders for the Pacific Region, the procedures set out in the following documents will be used to verify the structural integrity of the platform:

- a. Operating Procedures for the Platform Verification Program.
- b. Requirements for Verifying the Structural Integrity of OCS Platforms.
- c. Appendices to Requirements for Verifying the Structural Integrity of OCS Platforms.

The twelve main legs will be framed with horizontal and diagonal bracing which will provide a high degree of redundancy and add substantially to the stability of the platform under severe weather or earthquake loads. The structure will be secured to the ocean floor with piles driven through the main legs and attached by welding and grouting.

A wind, wave, current, and storm study of the specific site has been completed. A program of soil borings, soil analysis, and development of earthquake response spectra and soil spring analysis is being performed. Final piling and platform design will be based on information from the soil boring analysis. The above studies will provide information on sediments at the platform site, data for piling design and driveability, and ocean bottom hazards.

The structure will be thoroughly analyzed by a Certified Verification Agent. Union Oil Company of California, Science and Technology Division personnel will be made available on a consulting basis for assistance in the structural analysis.

To facilitate this project, one or more contractors will be engaged to provide engineering, fabrication, transportation, and installation. The principal components of the structure are the jacket, piling, and deck sections. These components will be constructed in a suitable fabrication yard and transported to the erection site. The jacket will be launched from a specially constructed barge and lowered to the ocean

bottom by controlled flooding, utilizing equipment aboard the derrick barge for partial support and final structural position. The piling will then be driven to the design depth through each of the 12 jacket legs, the jacket leveled, and the piling welded to each of the 12 jacket legs. The production deck sections will then be secured in place atop the piling. Following installation of the production deck, major production and support equipment components will be placed on the deck for future installation. The drill deck will then be set in place above the production deck. Two 70-ton diesel-powered cranes will then be installed and placed in service.

Two drilling rigs will be installed using the platform cranes. Crew quarters will be provided for approximately 20 crewmen. Life support systems will be provided for the maximum number of people to be onboard the platform at any given time.

Corrosion control of the platform will be accomplished by sacrificial anodes below MLLW, Tidegard 171 in the splash zone and protective paint (inorganic-zinc) or galvanizing where applicable above MLLW.

Exhibits VI-A and VI-B are elevations of the platform. Exhibits VI-C, VI-D, and VI-E are layouts of the drilling deck, production deck, and sub-deck.

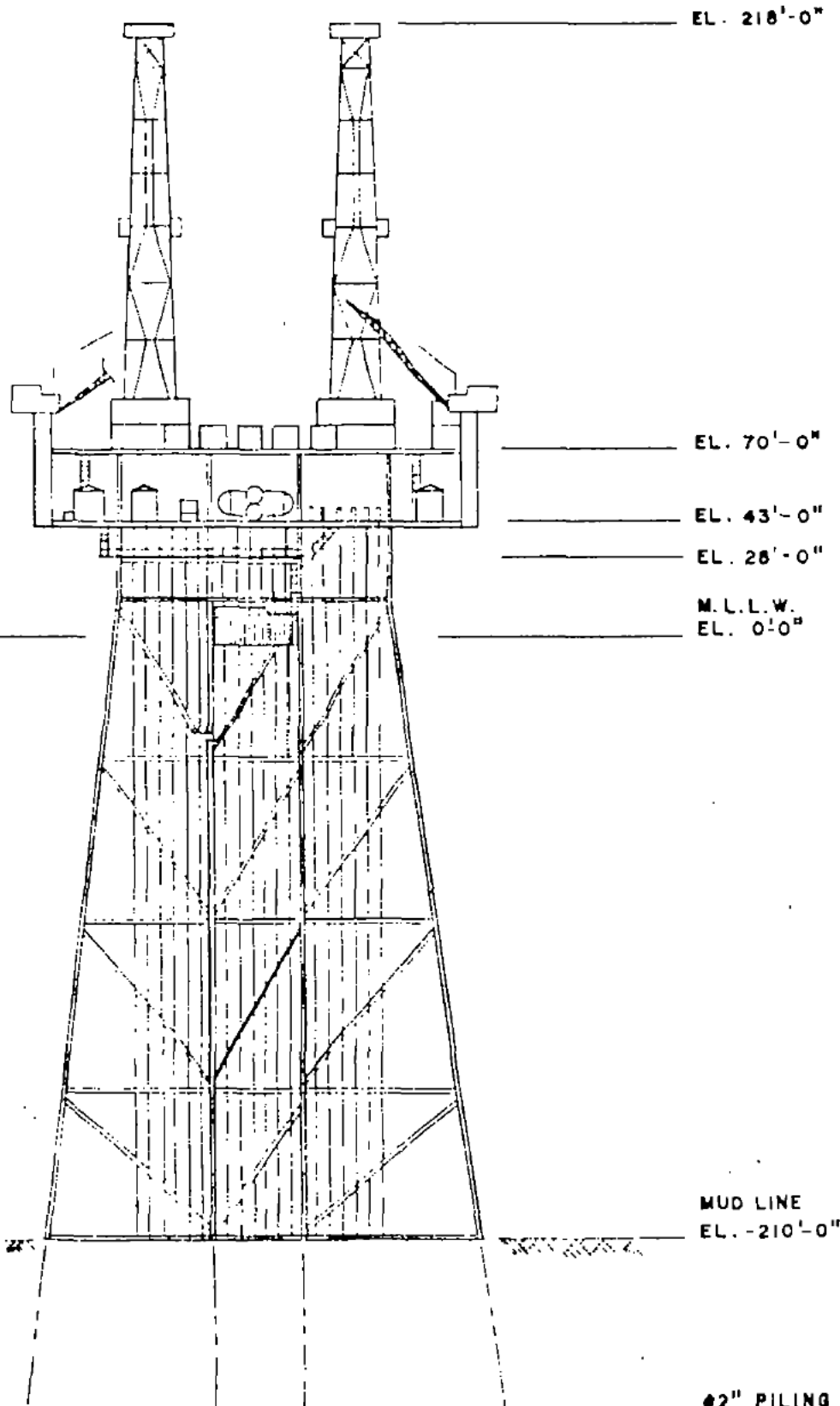

WEST ELEVATION
LOOKING EAST

union
Union Oil Company of California
Los Angeles, California

MEMBER SIZES & EXACT CONFIGURATIONS ARE NOT SHOWN
UNTIL FINAL DESIGN ENGINEERING & STABILITY CHECKS ARE COMPLETE

EXHIBIT VI-A

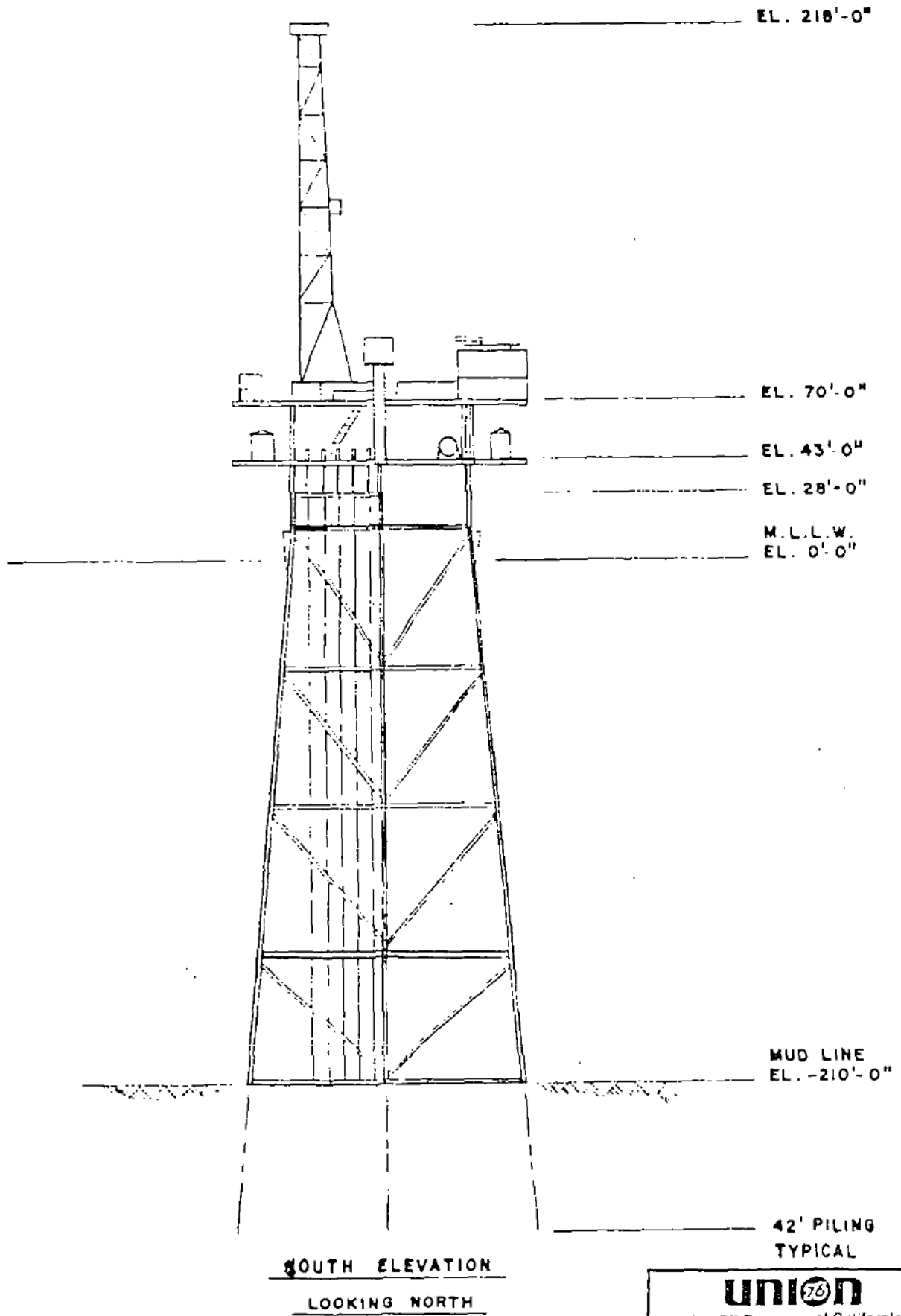

union
 Union Oil Company of California
 Los Angeles, California

MEMBER SIZES & EXACT CONFIGURATIONS ARE NOT SHOWN
 UNTIL FINAL DESIGN ENGINEERING & STABILITY CHECKS ARE COMPLETE

EXHIBIT VI-B

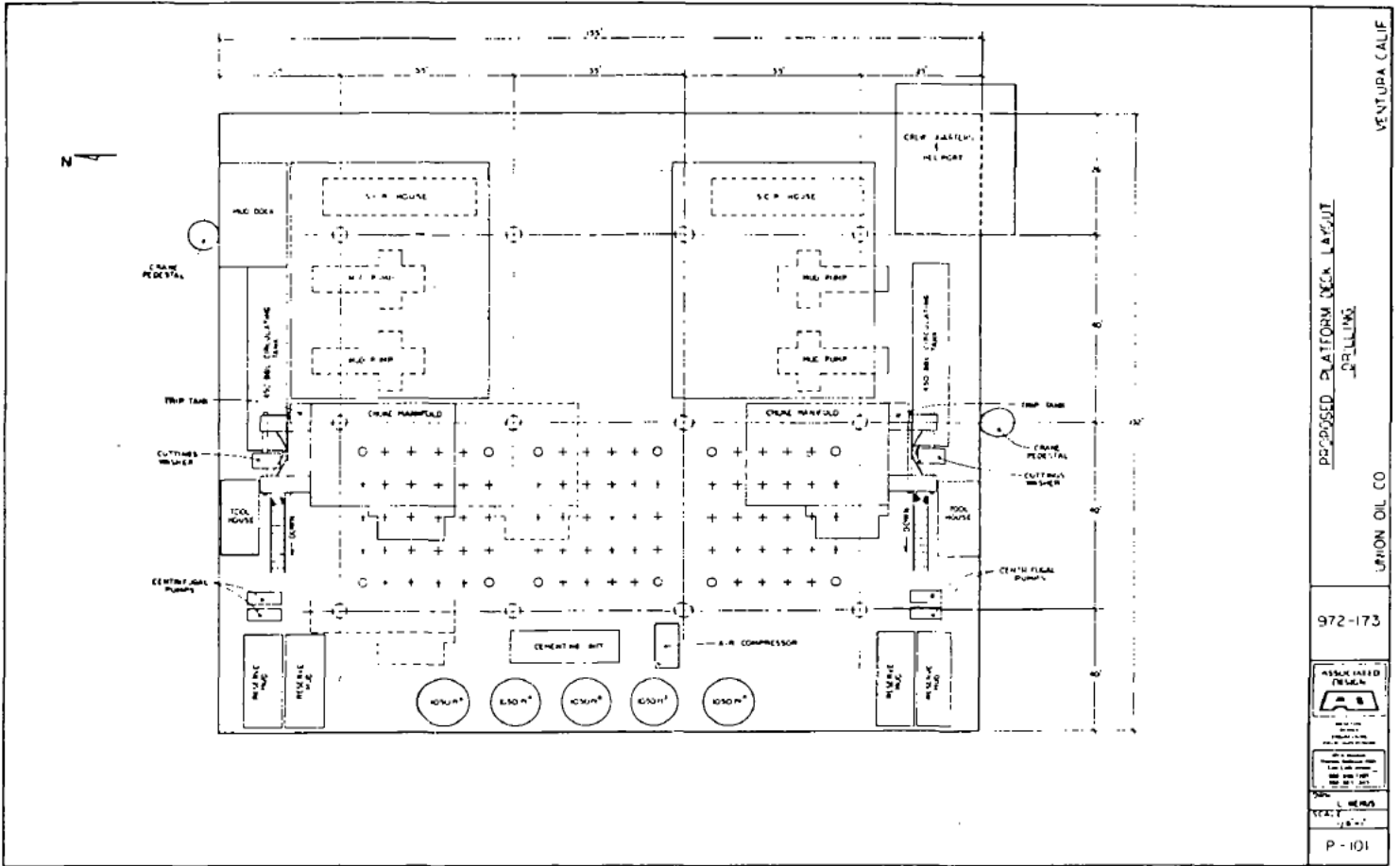
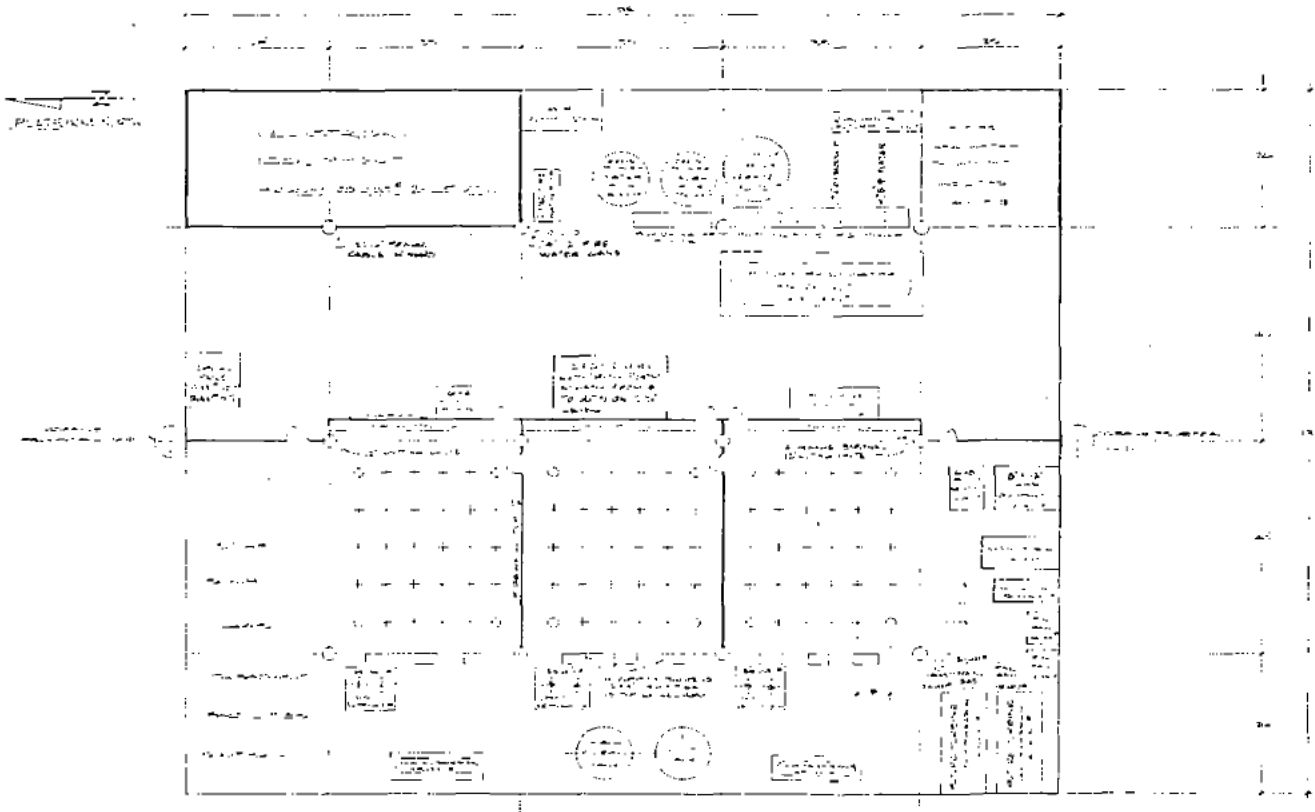

EXHIBIT VI-C



LABORATORY RECORDS
 PRODUCTION
 WEAVER, G. CO

100-100
 ASSOCIATED
 100-100
 100-100
 100-100
 100-100
 100-100

EXHIBIT VI-D

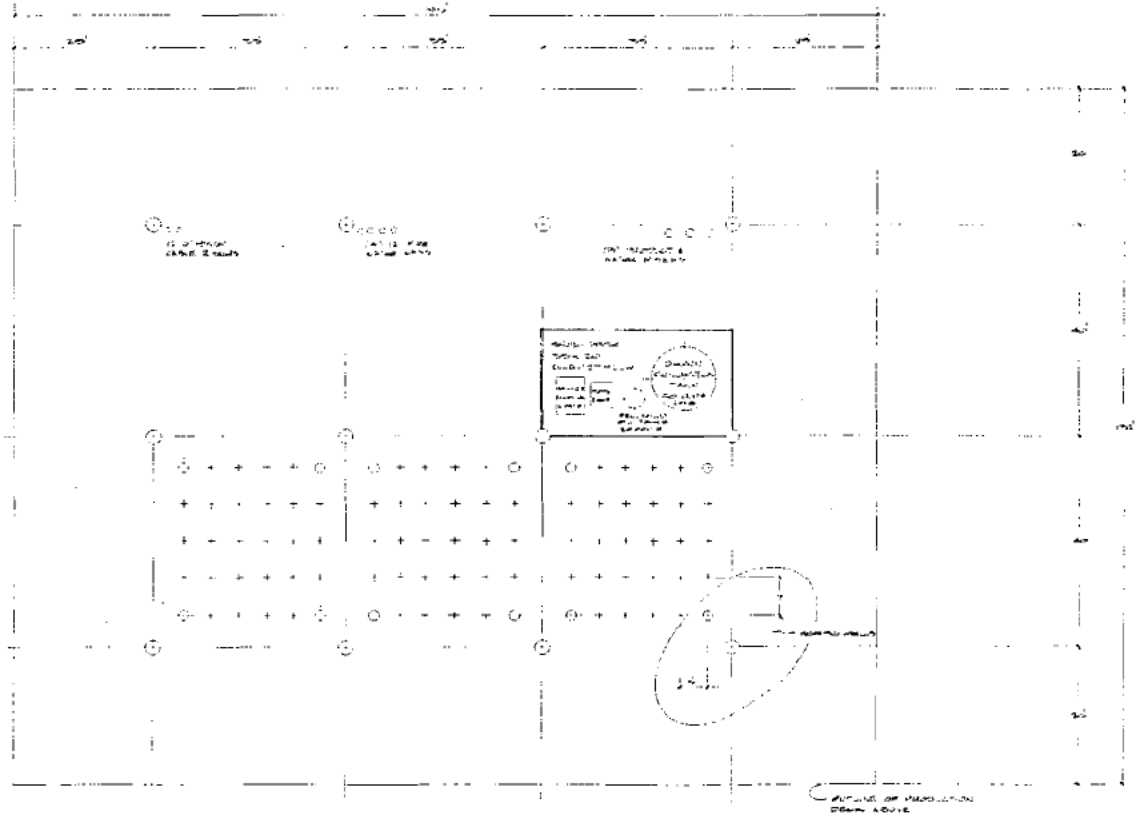
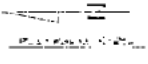

PLATFORM ORIENT.

972-83

ASSOCIATED DESIGN

DATE: _____

BY: _____

APP. BY: _____

DATE: _____

P-102

UNION OIL CO.

VERMONT, CALIF.

EXHIBIT VI-E

SECTION VII

PLATFORM DESCRIPTION AND SPECIFICATIONS

1. Number of well conductors 90 conductor guides sized for 24" conductors
2. Water depth 210'
3. Number of piles 12
4. Drill deck size 155' by 132'
 Elevation +70' MLLW
5. Production deck size 155' by 132'
 Elevation +43' MLLW
6. Sub-deck 40' by 20'
 Elevation +28' MLLW
7. Orientation - The platform will be orientated to offer the least resistance to the maximum wind and wave forces.
8. Piling design-The piling will be designed to support the platform under the worst combination of forces which might occur including the maximum credible earthquake, as determined by a qualified soil engineering firm.
9. The platform will be designed to satisfy the following conditions as set out in API RP2A-Tenth Edition:
 - (a) Strength requirements:

The response spectrum approach will be used to analyze the platform's earthquake strength requirements. The API response

spectrum for Zone 4-Soil Type A will be used for preliminary design. A site specific response spectra will be provided for the final design. The pile foundation will be modeled using an equivalent stiffness matrix to represent the foundation in the three-dimensional model. For the final design, this stiffness matrix will be provided by the Union-retained soils and foundation consultant.

(b) Ductility requirements:

Ductility will be demonstrated by showing that the structure-foundation system can absorb four times the amount of energy absorbed at the strength design requirement without experiencing catastrophic structural failure.

10. Wind and wave design - 100-year maximum

Maximum wave	30'
Period	12 seconds
Direction of approach	145° east of north
Maximum wind	50 knots sustained
	75 knots gusts
Direction of approach	130° or 270° east of north

11. Current

2.5 knots at surface
1.2 knots at midpoint
0.8 knots at bottom
All toward WNW

12. Cranes - 2 One on north side of platform
 One on south side of platform
 Weight 77,000 pounds
 Maximum lift 76,000 pounds
 (Crane pedestals to be equipped for diesel fuel storage)
13. Heliport - 40' x 40' maximum capacity 8,000 pounds
14. Cargo hatch - 15 ft. sq. near center of drill deck
15. Maximum drilling deck load - Maximum dead load 2,546 Kips
 Maximum live load 3,990 Kips
16. Maximum production deck load - Outside of well room, uniform deck
 loading of 400 lbs./sq. ft.
 Maximum live and dead loads on
 production deck will not exceed
 2,500 Kips.
17. Maximum sub-deck load - 100 Kips
18. South boat landing - 2-tier, for secondary use equipped with boat
 bumpers.
19. North boat landing - 3-tier, for primary use equipped with boat
 bumpers.
20. Barge and boat bumpers - tie-offs and boat bumpers supplied for
 north and south sides of platform.

21. Pipeline risers - 1 - 12.75" OD .500 w.t. 5LX42 series 900 ASA fittings - test pressure 3240 psig
1 - 10.75" OD .500 w.t. 5LX42 series 900 ASA fittings - test pressure 3240 psig
1 - 6.625" OD .280 w.t. 5LX42 series 900 ASA fittings - test pressure 3240 psig

All risers will be clamped to the structure in accordance with Department of Transportation regulations.

22. Power cable conductors Two 6"
23. Sewage disposal conductor One 4" from +14' to -180' MLLW
24. Drill cutting conductor Two 12" from +14' to -150' MLLW
25. Fire and seawater conductors Four 12" from +15' to -70' MLLW
26. Corrosion protection in splash zone - Tidegard-171
27. Protective coating - Ameron Dimetecote D-3 or equal
28. Cathodic protection - sacrificial anodes attached to platform jacket
29. Drains - All decks will be equipped with curbs and drains. Drain lines will connect to the sub-deck where effluent will be treated before shipment or disposal.
30. Decks - All decks to be sheet steel seal welded to the supporting beams. All decks will be equipped with guard rails which conform to OSHA regulations.
31. Stairs - All stairs will be equipped with guard rails which conform to OSHA regulations.
32. Well conductor deck penetrations on the production deck will be 26" ID with a lip extending 2" above the elevation of the deck curb.

33. Well conductor penetrations on the drill deck will be 30" ID with a lip extending 2" above the elevation of the deck curb. A cover will be provided for each penetration.
34. The platform and its appurtenances will comply with all applicable codes, laws, and regulations of the Federal Government including, but not limited to, the U.S.G.S., U.S.C.G., OSHA, Department of Transportation and Department of Commerce. Appendix B lists the several codes, specifications and recommended practices which will be used to assure compliance.

SECTION VIII

PLATFORM FACILITIES

The platform will be equipped with the following items which are considered support for the drilling and production operations.

1. One electrically driven fire water pump.
2. One diesel-driven fire water pump.
3. Two 70-ton-capacity cranes with 100-foot booms.
 - (a) One on north side of drilling deck.
 - (b) One on south side of drilling deck.
4. One 2.5-ton crane on production deck.
5. Deck drain collection and disposal system.
6. Potable water tank and pump.
7. Sewage disposal unit. (Similar to Microphor Marine Sanitation Device - uses bacterial action to reduce sewage to liquid and carbon dioxide.)
8. Public address system.
9. Alarm system.
10. Navigational aid (fog horn + lights) as required by U.S. Coast Guard.
11. Life saving and floatation equipment.
12. First aid equipment (Company personnel will be qualified through Red Cross First Aid training).
13. Fire hose reels and fire monitors as required.
14. Portable chemical fire extinguishers on the rig floor, on the drilling and production decks, and in enclosed areas.
15. Direct telephone communications.
16. Radio communications.

17. Hydrocarbon gas detectors.
18. H₂S detectors.
19. Flame detectors.
20. Oil containment and cleanup equipment consisting of:
 - (a) 1,000' of Kempner 8" Sea Curtain oil containment boom.
 - (b) One Acme 51 T oil skimmer.
 - (c) Ten drums of Corexit #9527 oil dispersant.
 - (d) Three boxes of Conwed sorbent boom.
 - (e) Three boxes of Conwed sweeps.
 - (f) Such other equipment as required by the USGS Area Supervisor.
21. Utility air system.
22. Instrument air system - including air dryer.
23. Fire water deluge system in all well rooms and other critical locations on the production deck.

SECTION IX

PRODUCTION SYSTEM

An artificial lift system will be installed in each producing well to deliver produced fluid to the surface at a pressure of approximately 200 psig. Gas from the annulus will be gathered in the platform gas gathering system. Each well will be equipped with surface-controlled subsurface safety valves in both the production tubing and the annulus as well as surface safety valves and check or flow safety valves. All piping will be designed to withstand maximum shut-in well pressure. Safety and anti-pollution control equipment will be designed and installed to comply with current OCS Orders for the Pacific Area and the latest editions of applicable API Recommended Practices.

Exhibits IX-A, B, C, D, E, and F are typical of the safety and anti-pollution controls which will be used to assure compliance. Each exhibit makes reference to the applicable API Recommended Practice. Symbols used are taken from API Recommended Practice 14C and are the standards of the Instrument Society of America. A complete listing of codes and specifications to be used are included in appendix B.

Oil from the wellhead will flow to a header system. The header system will be connected to a gross separator and/or through diverting valves to a test separator. From the gross separator and/or the test separator, fluid will flow to a shipping surge tank for pipeline shipment to the onshore treating facility. Gas will be gathered from the

separators and the well annuli, compressed to pipeline pressure, dehydrated by refrigeration, and transmitted to the onshore site. All vessels on the platform will be connected to a vapor recovery system which will discharge into the gas gathering system. All pressure vessels containing gas will be connected to an emergency vent gas scrubber and gas vent safety system. The gas scrubber will be sized to contain entrained liquids which might be carried through the vent system in the event of an emergency shutdown. It is estimated that the water content of the produced fluid will gradually increase over the life of the field, reaching 20% in 1985. If required at that time, a free water knockout and water treating system will be installed. Water separated on the platform would be treated by an induced gas flotation cell and filters before being injected into the producing formation.

Fluid production from the platform will be measured through a Custody transfer meter, then pumped through a 12.75" OD pipeline to the onshore site at Mandalay. At the onshore site, the fluid will pass through a gas separator, a free water knockout, a heater treater, a shipping surge tank, and through a Lease Automatic Custody Transfer (LACT) Unit into the pipeline.

At the onshore site water will be gathered from all sources and treated in an induced gas flotation cell. Treated water will then be pumped through 6-5/8" OD pipelines to either Platform Gina or Platform Gilda for injection.

Platform Gilda gas production will be compressed to pipeline pressure, treated for dew point depression, measured, and transferred to the onshore site. At the onshore site, the gas will be commingled with the treated gas from the onshore process vessels and transferred to the gas purchaser's pipeline system.

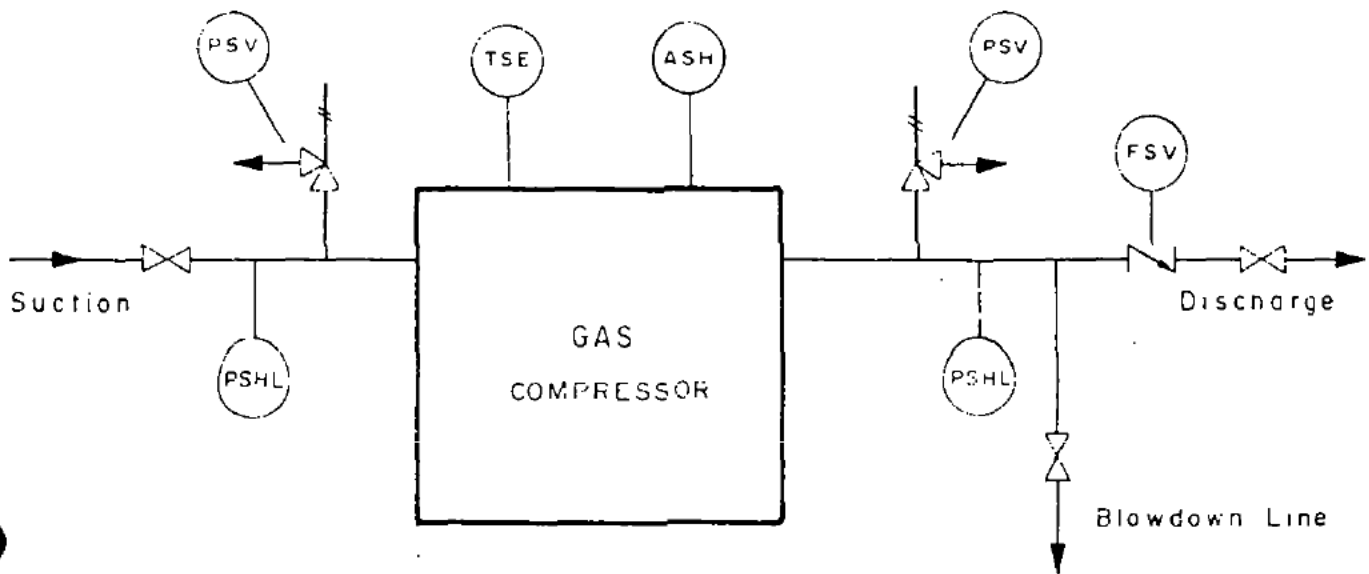

Note: See fig. for typical gas scrubber safety devices.

Ref: API RP 14C Second Edition

UNION
 Union Oil Company of California
 Los Angeles, California

TYPICAL GAS COMPRESSOR INSTALLATION

EXHIBIT IX-A

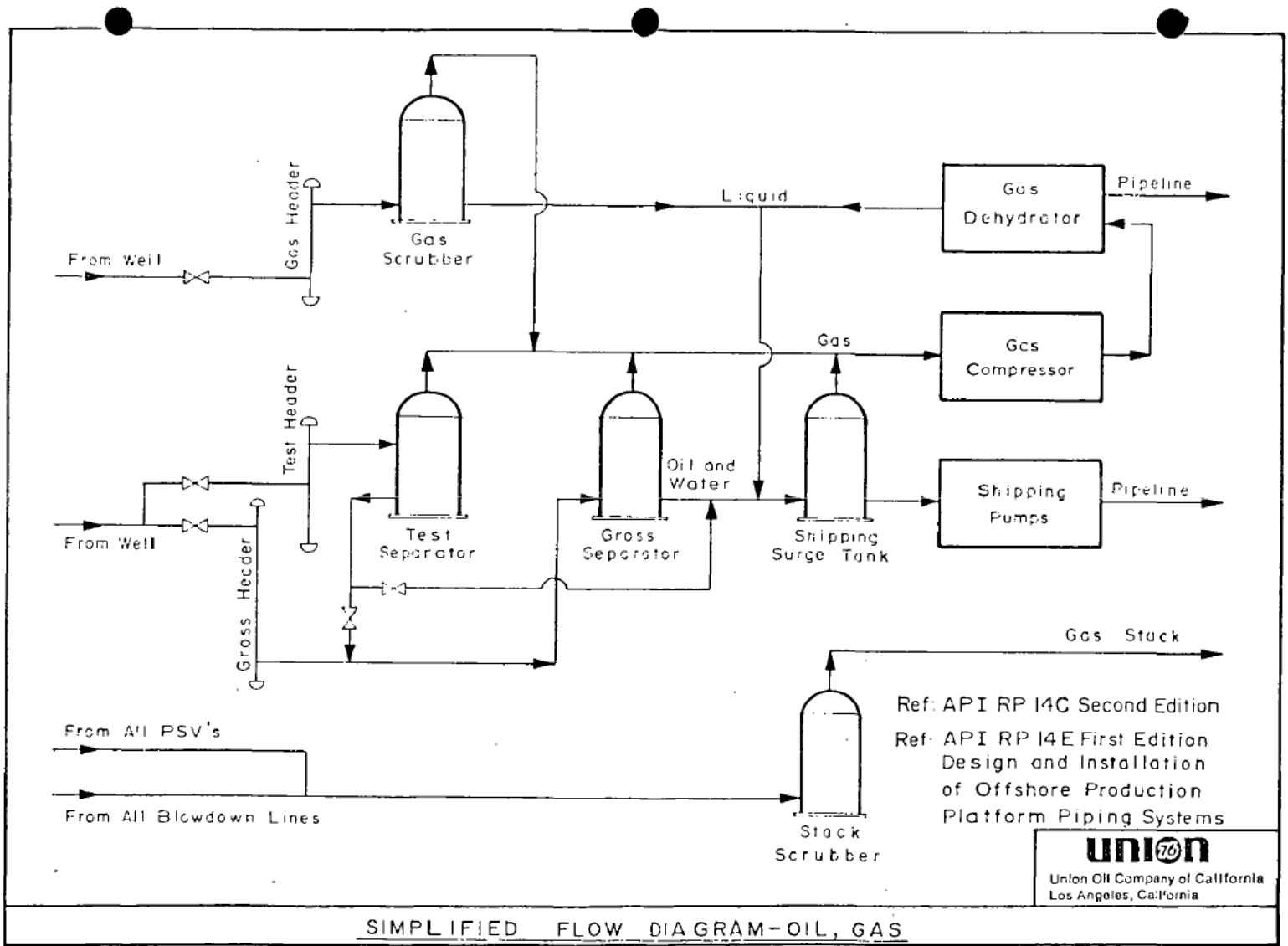

SIMPLIFIED FLOW DIAGRAM-OIL, GAS

EXHIBIT IX-B

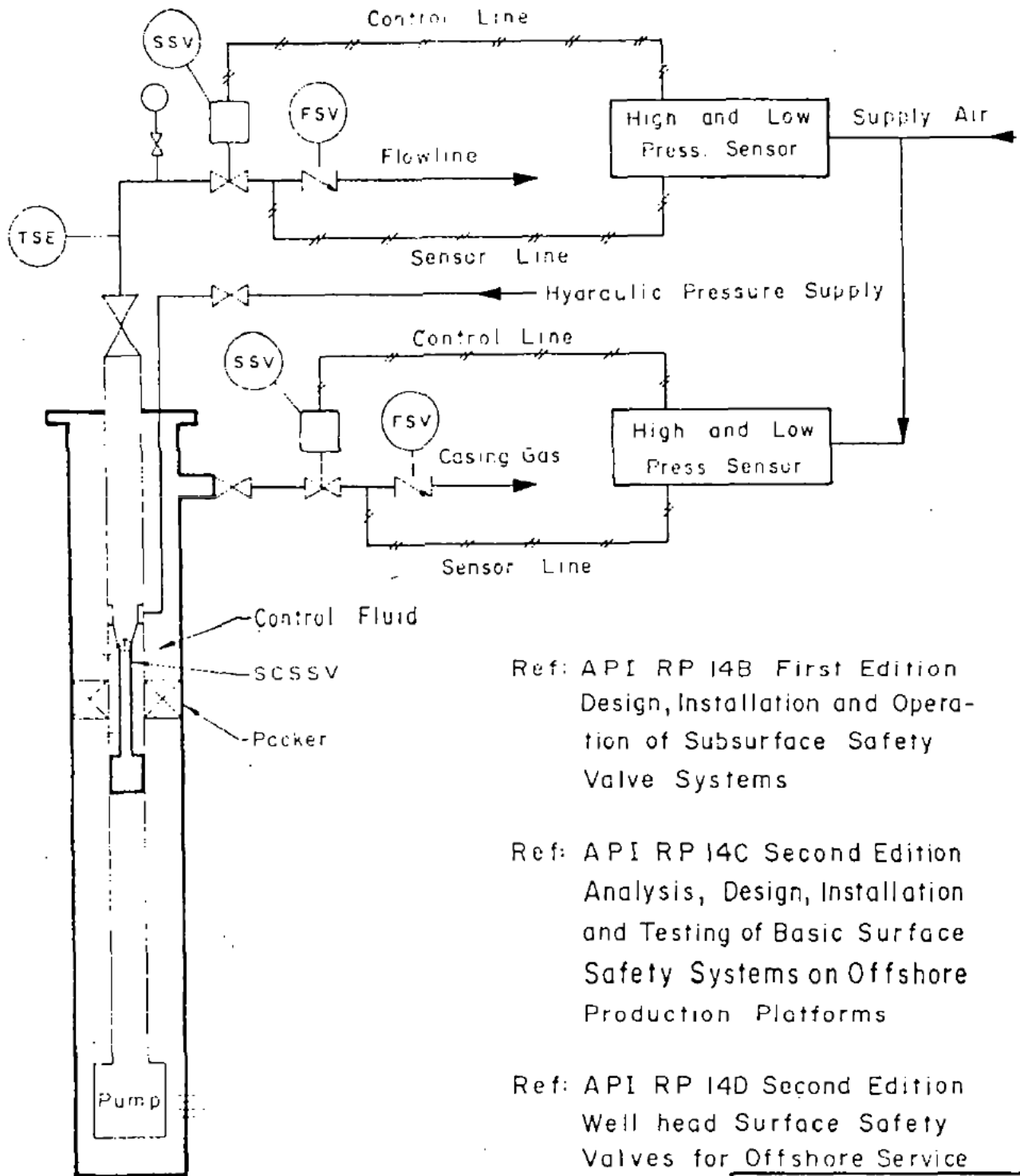

Ref: API RP 14B First Edition
Design, Installation and Operation
of Subsurface Safety
Valve Systems

Ref: API RP 14C Second Edition
Analysis, Design, Installation
and Testing of Basic Surface
Safety Systems on Offshore
Production Platforms

Ref: API RP 14D Second Edition
Well head Surface Safety
Valves for Offshore Service

union⁷⁶

Union Oil Company of California
Los Angeles, California

TYPICAL INSTALLATION AND OPERATION OF SURFACE CONTROLLED
SUBSURFACE SAFETY VALVES (SCSSV), SURFACE SAFETY VALVES
(SSV) AND HIGH AND LOW PRESSURE SENSORS.

EXHIBIT IX-C

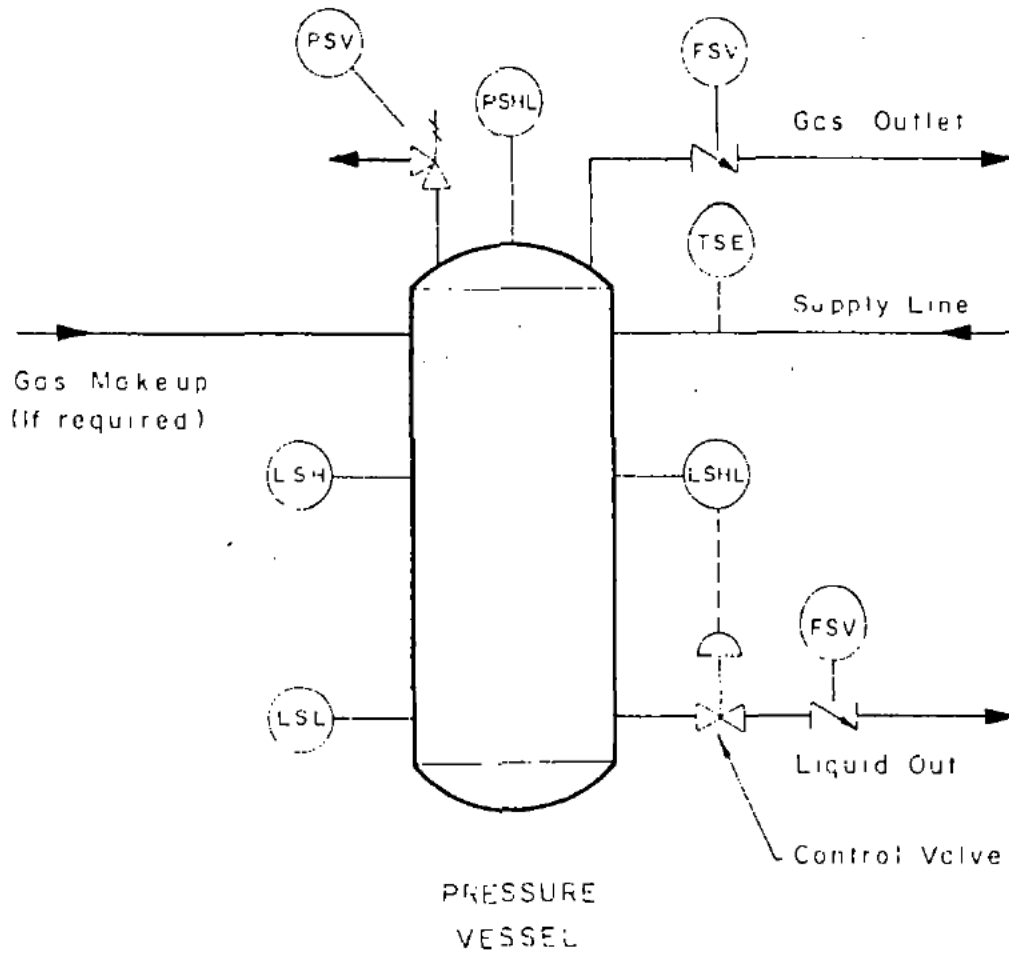

Ref: API RP 14C Second Edition
 Analysis, Design, Installation
 and Testing of Basic Surface
 Safety Systems on Offshore
 Production Platforms.

union⁷⁰
 Union Oil Company of California
 Los Angeles, California

TYPICAL ALL PRESSURE VESSELS

EXHIBIT IX-D

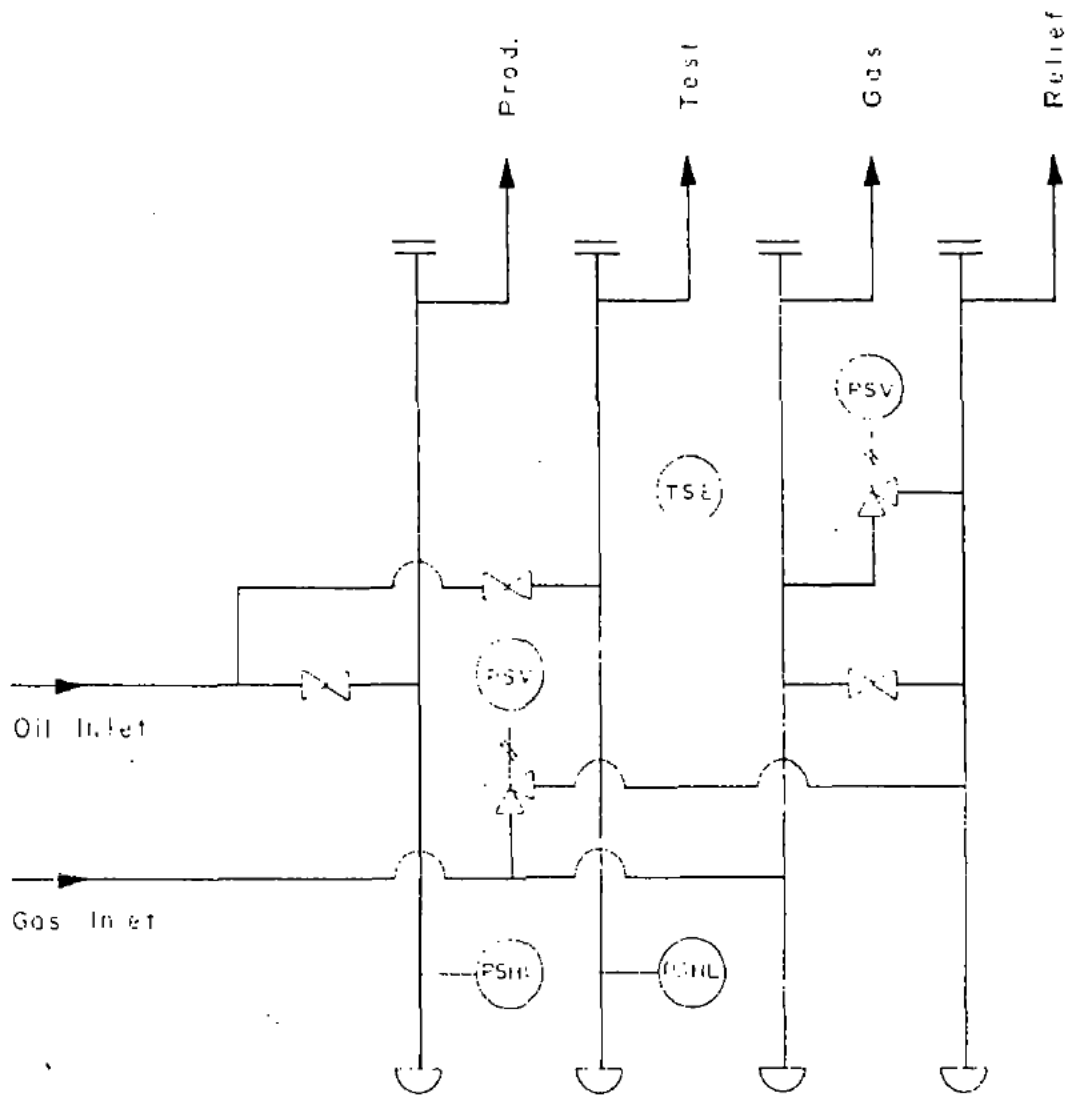

Ref: API RP 14C Second Edition

union 76
 Union Oil Company of California
 Los Angeles, California

TYPICAL HEADER SAFETY DEVICES

EXHIBIT IX-E

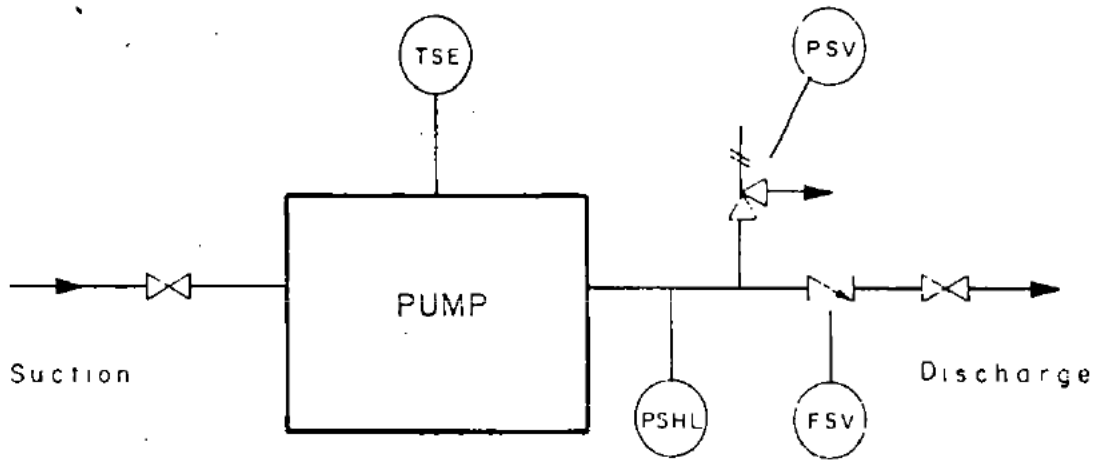

Ref: API-RP 14C Second Edition

union⁷⁶
Union Oil Company of California
Los Angeles, California

TYPICAL PUMP INSTALLATION

EXHIBIT IX-F

POWER

Power for the platform will be supplied by a submarine power cable from the onshore Mandalay site. Voltage will be transmitted at 16.0 KV. Maximum demand will be approximately 5,000 KVA during the drilling phase. When drilling is complete, the production load will be less than 2,000 KVA.

A small diesel-driven generator will be provided to automatically provide emergency power for Aids to Navigation, lighting, and other safety functions in the event of a power failure.

The power cable will be buried from the metering station to MLLW at a minimum depth of 6'. The cable will be covered by 6" of red concrete for protection. Experience has shown that from the surf line to the platform, the power cable will bury itself.

The alternates to a submarine power cable are discussed in section XVI.

ENERGY REQUIREMENTS

Diesel Fuel

During the construction phase, energy requirements will primarily include use of diesel fuel for offshore transportation of personnel, supplies, and construction equipment. During the drilling phase, diesel fuel will be used for crew boat operations, platform cranes, and supply boat operations. An order-of-magnitude estimate of diesel fuel consumption

during the construction and drilling phases of Platform Gilda is 200,000 gallons for the period September, 1980, to December, 1984. Thereafter, the diesel fuel requirement will be approximately 30,000 gallons/year.

Natural Gas

Natural gas will be used at the onshore processing facility to separate produced oil/water and associated gas from the combined production of Platforms Gina and Gilda. The source for this energy resource would be from the associated natural gas produced on both platforms. Estimated consumption of this resource while operating at peak production levels would be approximately 280 MMCF per year.

Electrical Power

During the drilling and production phases of Platform Gilda, electrical power would be used for all platform operations except for occasional use of cranes, emergency fire pumps, and the standby generator set. The source of electrical power will be from a submarine cable placed parallel with the transport pipeline system. Transmission voltage will be 16.5 KV. Maximum project power demand during the drilling phase will be approximately 5,000 KVA, which during the operating phase will be reduced to less than 2,000 KVA. Power requirements for the onshore site will be approximately 500 KVA for the life of the project.

SECTION X

SAFETY, ANTI-POLLUTION AND CONTROL SYSTEMS

Safety, anti-pollution and control systems will be installed on all piping headers, machinery, and vessels as required. The system will be a combination of electric and pneumatic controls. All automatic control valves will be designed to be fail-safe. Control devices will include the following:

1. High-low pressure alarm and shutdown sensors.
2. High-low liquid level alarm and shutdown sensors.
3. Flow safety valves.
4. Pressure safety valves.
5. Vibration sensors.
6. High-low temperature alarm and shutdown sensors.

All of the above items will be designed and installed to facilitate testing. The devices will be tested for accurate operation on a schedule to be approved by the U.S.G.S.

All of the above safety devices will be interconnected through a central control panel. When a malfunction occurs, an alarm will be sounded; and if the condition is not immediately corrected, the platform will shut down. Shutdowns will be accomplished by automatically closing the surface controlled subsurface safety valves and the surface controlled surface

safety valves. Produced fluid will continue to move off the platform through the pipeline until the equipment is automatically shut down by either low levels or low pressure. If the malfunction is pipeline related, liquids would not be pumped off the platform, but instead the vessels would automatically shut in and contain the production.

A contingency plan describing actions to be taken in the event of encountering hydrogen sulfide gas while drilling is included in appendix C.

SECTION XI

PIPELINE SYSTEM

It will be necessary to install three pipelines from the platform to the onshore site. The oil pipeline will be 12.75" OD .500" wall thickness 5LX42 equipped with Series 900 ASA fittings and have a working pressure of 2160 psig. Test pressure will be 3240 psig. API RP1111 will be used as a guide for design along with USGS OCS Orders for the Pacific Area, Department of Transportation Reg. 49, part 195 and ANSI B 31.4. Safety and pollution control equipment will include automatic shutdown valves, flow safety valves, and pressure sensors high and low.

The gas pipeline will be 10.75" OD .500" wall thickness 5LX42 equipped with Series 900 ASA fittings and have a working pressure of 2160 psig. Test pressure will be 3240 psig. API RP1111 will be used as a guide for design along with USGS OCS Orders for the Pacific Area, Department of Transportation Reg. 49, part 192 and ANSI B 31.8. Safety and pollution control equipment will include automatic shutdown valves, flow safety valves, and pressure sensors high and low.

The return water pipeline will be 6.625" OD .280" wall thickness 5LX42 equipped with Series 900 ASA fittings below MLLW. This pipeline will be built and tested to the same specifications as the oil pipeline.

All of the pipelines will be externally coated with a 70-mil high density polyethylene protective coating. Cathodic protection will be pro-

vided by sacrificial anodes in bracelet form attached to the pipelines in a manner which will not create a hazard to the fishing industry.

The most probable method of installation is the pull method. The three pipelines will be individually but simultaneously welded together, and as sections are completed, the pipeline will be pulled offshore to the platform. Buoyancy will be added to minimize the drag on the pipe. When the pipelines are pulled to the platform, they will be connected underwater to the platform risers by divers. The pipelines will be buried through the surf line out to a water depth of 20'. From MLLW to the onshore site, the pipelines will be buried a minimum of 3'.

The method of burial through the surf line involves a minimum of trenching with a tractor or backhoe. Seaward from the surf line, the pipelines will be buried by diver jetting the sand from under the pipelines, allowing them to sink. As the pipelines sink, the jetted sand will settle back in place over the pipelines with a minimum of disturbance to the ocean floor.

There are no plans to do any dredging in connection with the pipeline installation.

The welding specification to be used is API 1104. All welds will be inspected by x-ray. Before construction, a complete set of certified plans will be submitted for approval. Exhibit XI-A shows the proposed pipeline route.

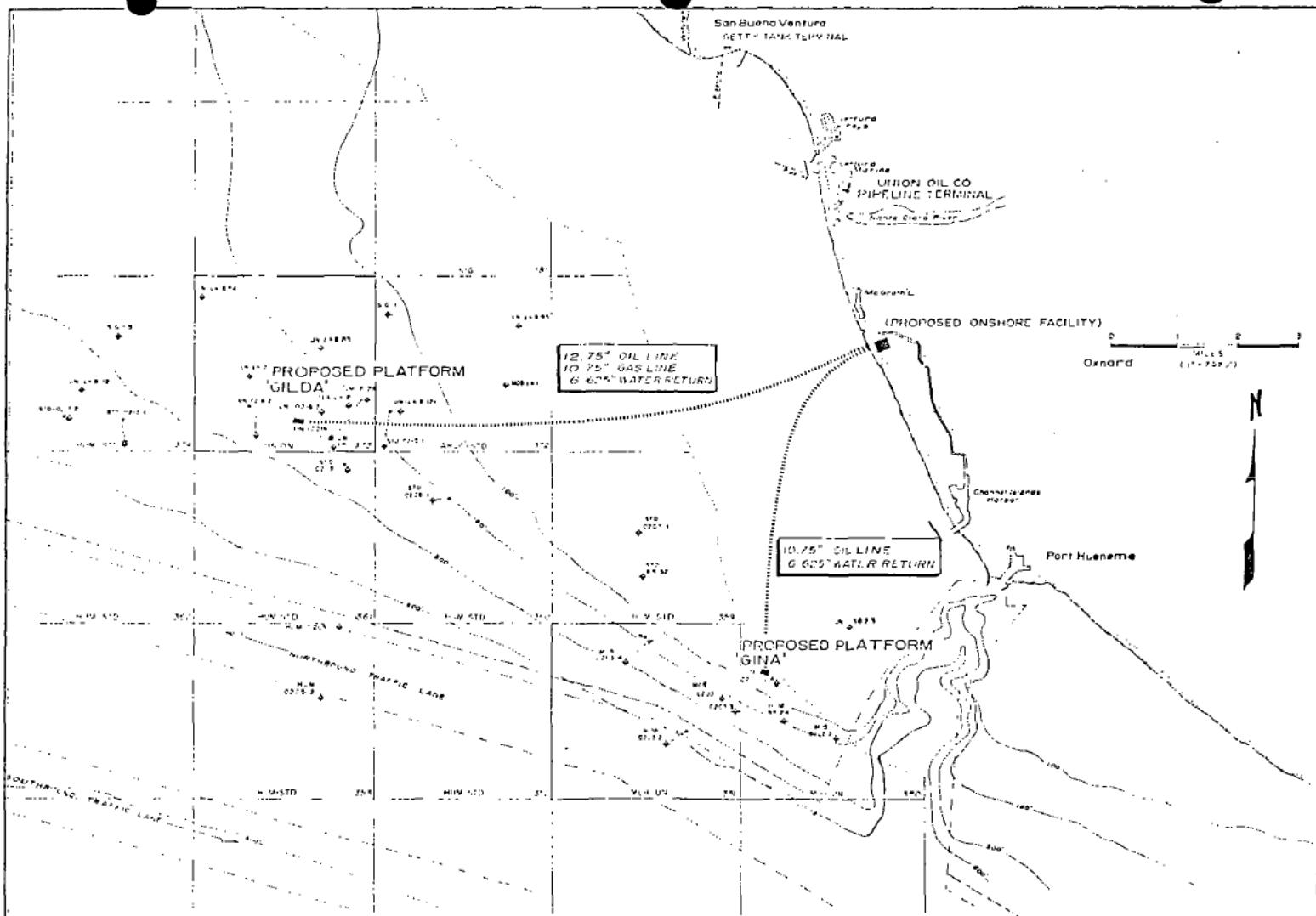

EXHIBIT XI-A

SECTION XII

ONSHORE SITE

The onshore site will be located immediately south of the Mandalay Power Plant in the northwest corner of the proposed Ventura County Mandalay Beach Park. The site will be 200' by 400' (1.8 acres). On the south and west sides, visible to the public, the facility will be surrounded by a camouflaging block wall fence. On the north and east sides, visible only from inside the power plant, the facility will be surrounded by a chain link fence. The onshore site will be landscaped to blend in with the Mandalay Beach Park after discussion with the County. The facility will be located approximately 460' inland from the beach.

The proposed onshore site has been designed to treat oil from both Platform Gilda and Platform Gina. Since the viscosity of the oil water emulsion from Platform Gilda will vary with the percent water, it will be necessary to transport oil from the two platforms in separate pipelines. Effluent from Gilda will be transported through a 12.75" pipeline, arriving at the onshore pig receivers at a pressure of ± 150 psig. From the pig receivers, the effluent will go to a three-phase separator where gas will be flashed off at a pressure of ± 100 psig, free water drawn off the bottom, and the remaining oil water emulsion will go to the economizers on the heater treaters. Exhaust gas from the heater treaters will enter the economizers at a temperature of approximately 800° F. After preheating in the economizer, the emulsion will go to the free water knockout where free water will be drawn off. The remaining emulsion will then receive final treatment in the heater treaters, then

to to the shipping surge tank, the Lease Automatic Custody Transfer unit and into the pipeline.

Water from all the facility vessels will be gathered in a wash tank. Oil collected in the wash tank will be treated in either the main treating system or the small 1 MM BTU/hr. heater treater.

All vessels will be connected to a vapor recovery system. Sumps and wash tanks will be sealed.

Gas from the pipeline and onshore pressure vessels and tanks will be gathered, compressed to pipeline pressure, dehydrated for dew point depression, and sold directly into the gas pipeline. Any hydrocarbon condensate will be shipped with the oil.

The onshore treating facility will be 200' x 400' (1.8 acres). A close examination of this site reveals that the 200' x 400' configuration will fit easily into an area which is flat and behind sand dunes on the south and west sides of the Southern California Edison Mandalay power generation station. By using this configuration, the existing dunes and vegetation will be minimally disturbed both during the construction and operation phases.

Gas handling and treating, water treating, and pumping capacities will be designed to handle the projected production. All of the equipment will be designed to present a low profile and will utilize best available control technology for pollution control. The onshore electrical metering

station will be within the confines of the site. Exhibit XII-A is a plot plan of the site. Exhibits XII-B, XII-C, and XII-D are artists' conceptions of the onshore site in relation to the existing power plant. Exhibit XII-E is a piping and instrumentation drawing of the onshore site.

The onshore site as proposed is the same as that which is currently under study by the EIR/ES contractor for the Hueneme project. The equipment to be installed will be essentially the same as for the Hueneme project except that the heater treaters will be increased in number from one to three.

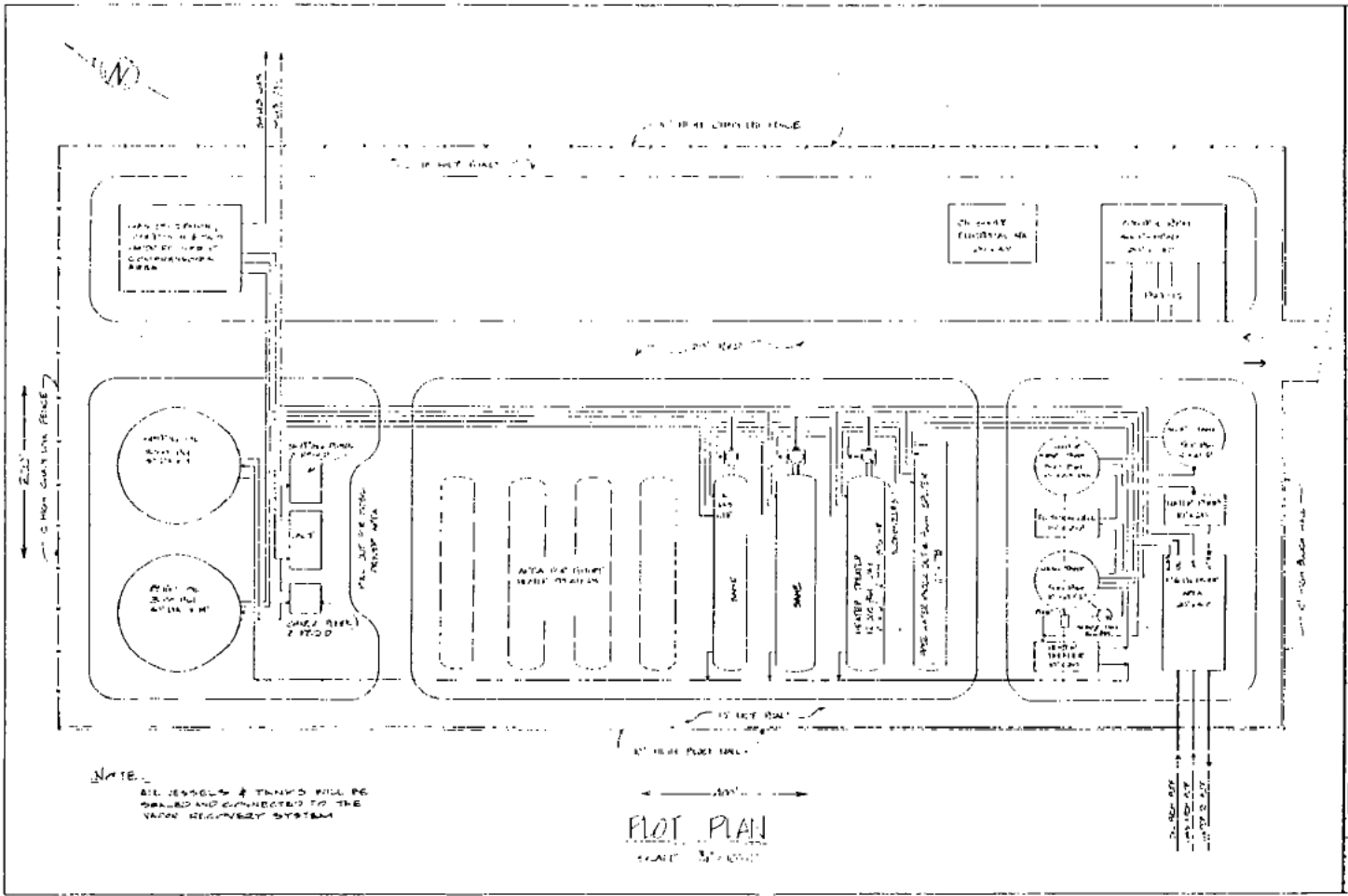

Job No. 172 18

1002

EXHIBIT XII-A

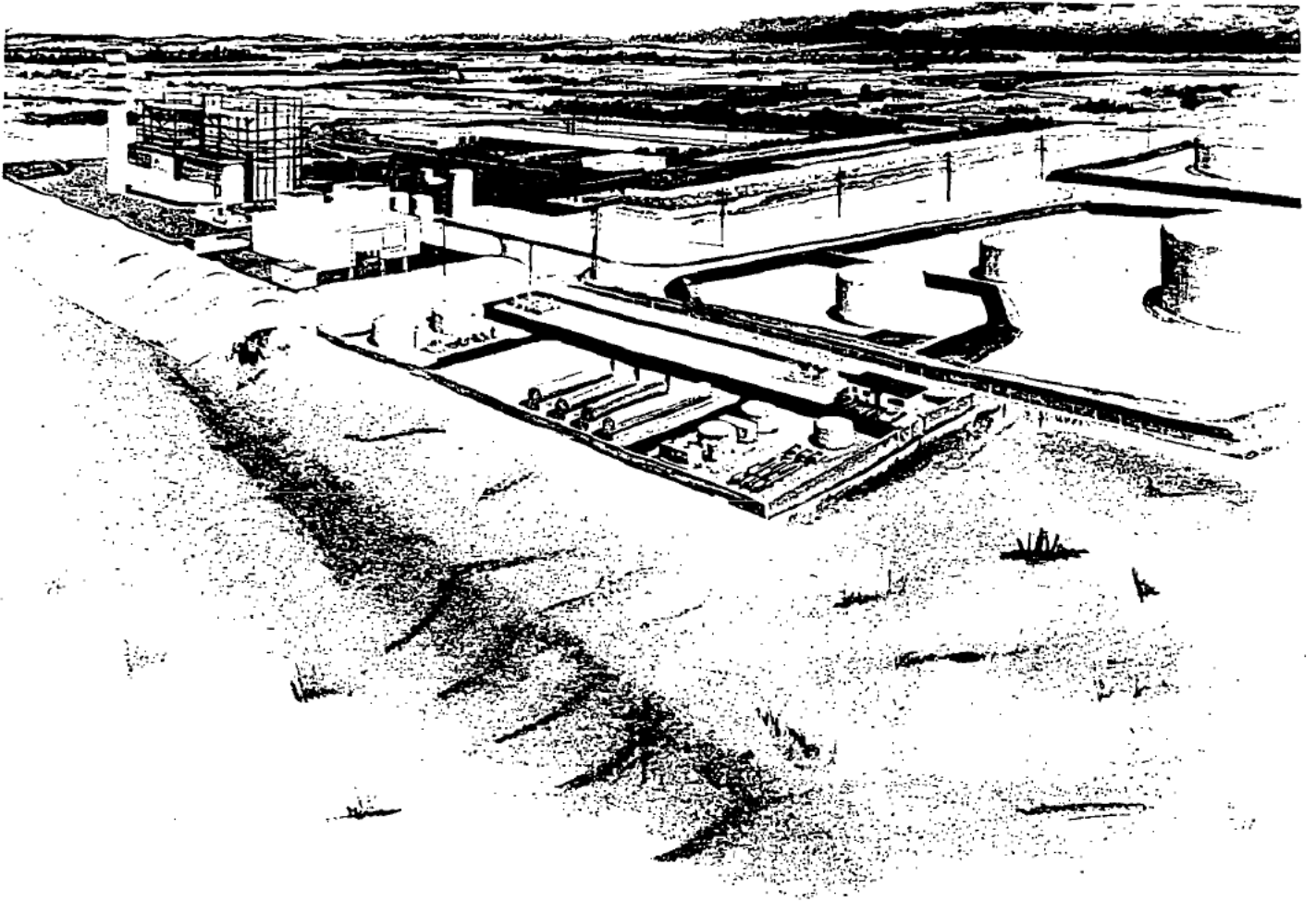
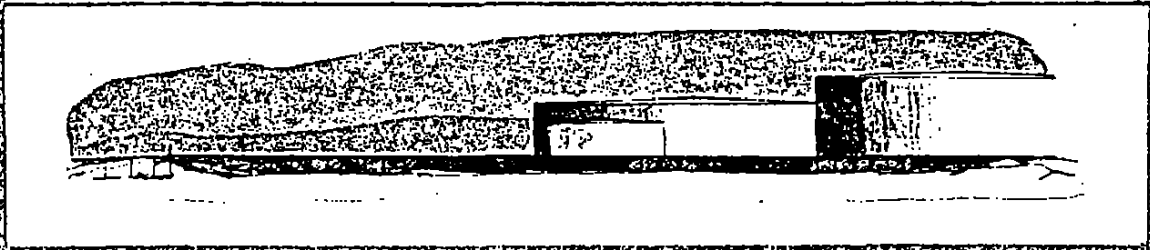
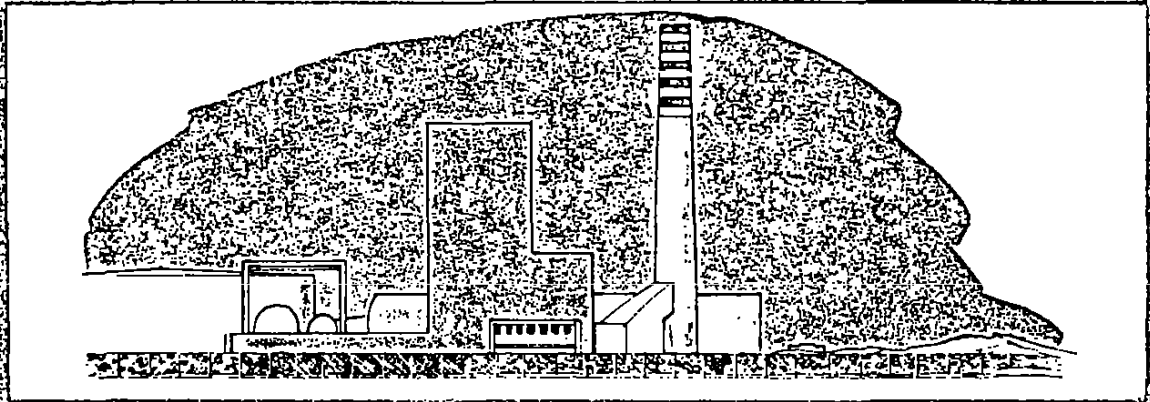

EXHIBIT XII-B



WEST



NORTH

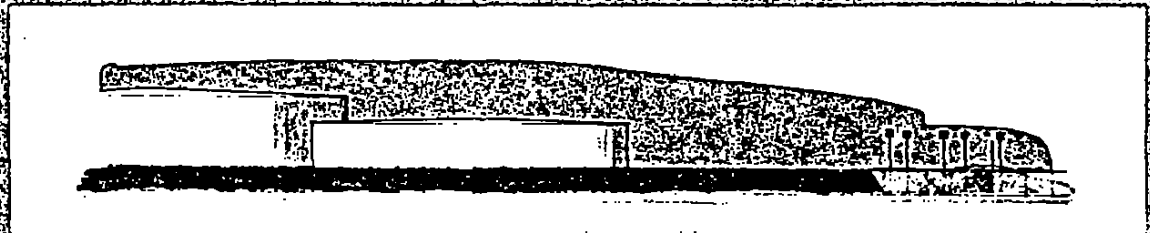

EAST

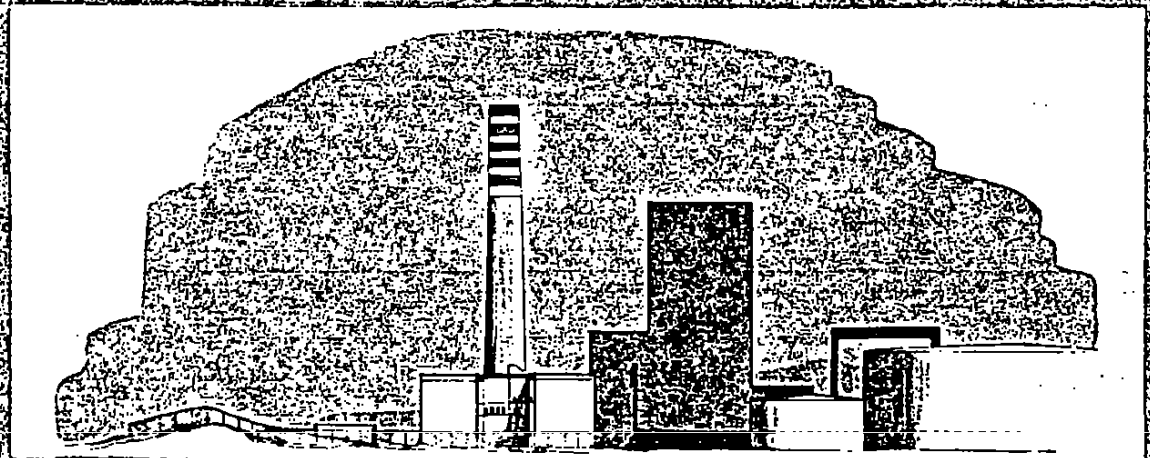

SOUTH

EXISTING
EXHIBIT XII-C

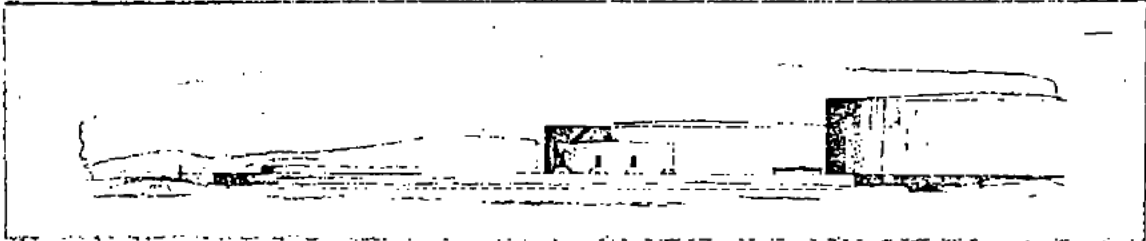

WEST

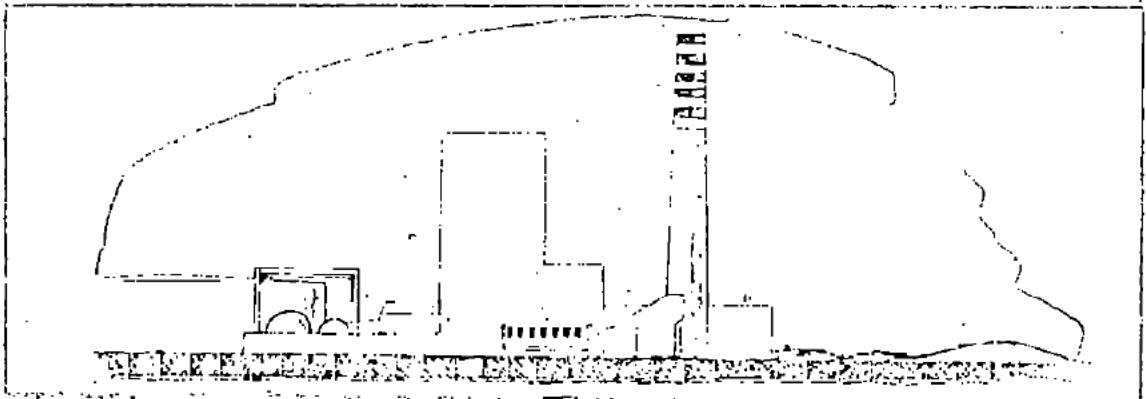

NORTH

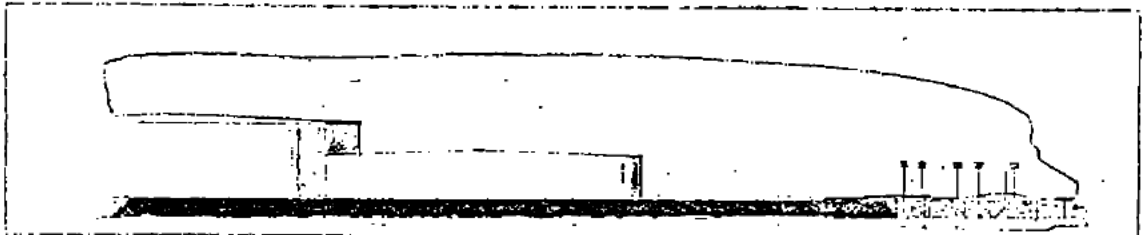

EAST

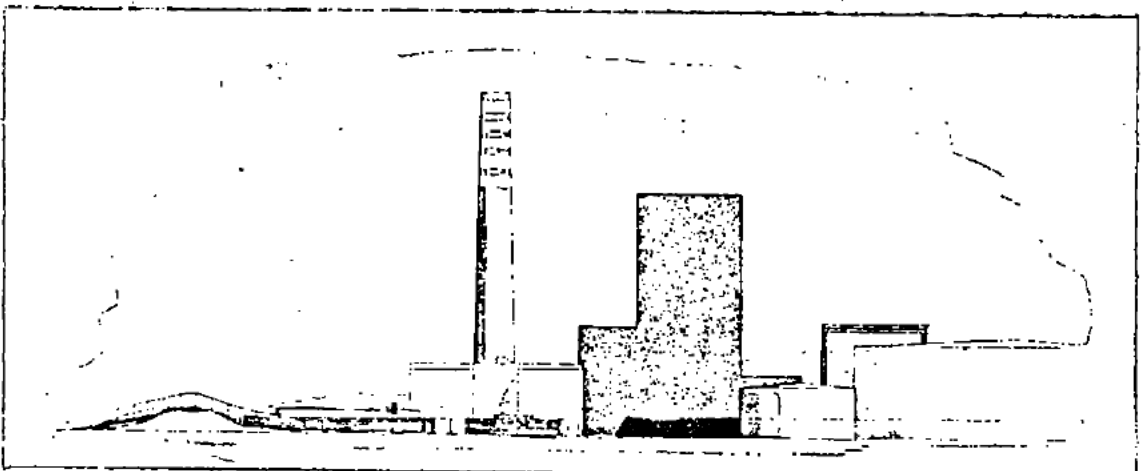

SOUTH

PROPOSED
EXHIBIT XII-D

SECTION XIII

OIL SPILL AND CLEANUP PLANS

Union Oil Company of California is a supporting member of various cleanup organizations on the West Coast. As a member, Union has call on the equipment and expertise of these organizations. OCS P-0216 is in the area covered by the Clean Seas, Inc. organization. CSI has secured the latest most efficient cleanup and containment equipment. Considerable time and effort is expended by CSI to train various company personnel in the operation of this equipment. Union Oil personnel participate in these training exercises. A copy of the CSI Contingency Plan, with equipment lists, is on file with various U.S.G.S. offices.

In addition, Union has its own contingency plan which is updated frequently. Since Union is the operator of three platforms on OCS P-0241, a high degree of efficiency has been developed in the use of platform pollution control equipment and safety and pollution control devices.

Before drilling and production is initiated, key platform personnel will be trained in the rapid deployment of the platform booms, the use of an oil pickup device (skimmer), the proper use of sorbent material and the proper use of dispersants. This equipment can be deployed and in use in less than one hour after an incident. In most cases, depending on the location of the crew boat, this time can be greatly reduced.

The company personnel needed to effectively direct and supervise beach, harbor and "unique area" protection can be mobilized within two hours.

Simultaneously, additional Union personnel will be utilized to mobilize the offshore cleanup equipment owned by CSI to control a spill in the ocean.

Because of the location of a number of Union's Operating Divisions in Southern California, an adequate number of people experienced in the supervision and control of oil spill cleanup can be mobilized within a period of four hours. This will be accomplished by contacting selected managers who will in turn activate personnel from within their own group.

A copy of the Union Oil Company of California's Oil Spill Contingency Plan for the Southern District, Ventura area, covering all operations in the Santa Barbara Channel, can be found in appendix D.

SECTION XIV

CRITICAL AND SIMULTANEOUS OPERATIONS AND CURTAILMENT PLAN

The following plan is designed to cover Union Oil Company of California's operations on OCS P-0216. The intent of this plan is to minimize, as far as practicable, performing certain critical drilling and production operations during those times when wind and/or sea conditions would seriously impede containment and cleanup of any oil spilled on the water, or seriously interfere with communications or transportation to the platform of any material needed in an emergency. "Critical Operations" are defined as those operations where a significant spill potential exists.

List of Critical Drilling and Production Operations on Offshore Wells

- A. Spudding in when in close proximity (within 20') of another pressurized well.
- B. Pulling out of the hole if a production formation, capable of flowing oil or gas to the surface, is exposed.
- C. Drilling in a known lost circulation zone if a formation capable of flowing oil or gas to the surface is exposed or will be exposed while lost circulation conditions exist.
- D. Formation (drillstem) testing.
- E. Running casing if a formation capable of flowing oil or gas to the surface is exposed.
- F. Cutting and recovering casing if a formation capable of flowing oil or gas to the surface is exposed.

- G. Conducting well logging or wireline operations.
- H. Perforating for production.
- I. Major maintenance or construction work involving welding or moving heavy equipment.
- J. Preventive maintenance which would require the shutdown of critical equipment.
- K. Routine testing of safety and anti-pollution control devices.
- L. Scheduled Abandon Platform Drills.
- M. Scheduled Fire Drills.
- N. Any unnecessary activity which, in the judgement of the platform supervisor, could result in a loss of efficiency or reliability of any of the platform drilling, production, support, or safety systems.

SECTION XV

CIRCUMSTANCES UNDER WHICH CRITICAL DRILLING AND
SIMULTANEOUS PRODUCTION OPERATIONS WILL BE CURTAILED

Critical drilling operations as defined above will not be commenced or conducted under the circumstances listed below:

NOTE: If a critical operation is in progress when one of these circumstances arises, the District Engineer, U.S.G.S., will be notified and the continuation or cessation of the critical operation will require the approval of the District Engineer and shall be based on a determination of whether immediate cessation of the operations might endanger the well or increase the risk of oil spillage.

- A. When a significant wave height is such that transportation or containment and cleanup operations would be seriously hampered.
- B. When winds exceed 40 knots.
- C. When the bulk of Clean Seas, Inc. or commercial contractor containment and cleanup equipment is out of the area or is being fully utilized at a spill in the area.
- D. When there are not enough boats in the area to deploy the necessary booms and skimmers.
- E. When there is an insufficient supply of drilling fluid materials to control the well.
- F. When the emergency containment and cleanup equipment is not at the approved location or is not maintained in good working order.
- G. When fog is so dense that visibility on the structure is limited.

H. When the manpower required to safely conduct the critical operations is not available.

If an unusual storm that endangers the safety of the platform should occur, or if the platform is threatened by fire from a spill from another facility, all operations will be suspended and the wells shut in in a safe and secure manner until the emergency is over.

SECTION XVI

ALTERNATES

A. Power Cable vs Onsite Power Generation

Before the decision was made to install a power cable from shore and purchase power from a public utility, the use of onsite generation was thoroughly investigated.

The conversion of natural gas or diesel oil into electrical power using turbine generators is relatively inefficient. Under normal operating conditions, the thermal efficiency is approximately 35% but can be increased to a maximum of 70% if the waste heat can be utilized. On the proposed platform Gilda, utilization of waste heat would be minimal, since no oil treating facilities will be on the platform. Additionally, it would initially be necessary to operate the turbines using diesel oil until gas production is established in sufficient quantities to provide an alternate source of fuel. Transportation of the diesel oil would cause an increase in boat traffic, with a proportional increase in emissions.

The power requirements for the platform will be greatest during the drilling phase, which will last approximately four years. When the drilling is complete, the production power requirements and the occasional remedial well work power requirements will be only 40% of the installed capacity. Thus, the installation of generating equipment is not cost effective.

Air pollutants from the turbines would be in excess of 50 tons/year and the space requirements for the turbine generators would impose limitations on the amount of additional space available for the use of No_x converters and/or So_x scrubbers. Additional platform space can normally be provided for, but for this project, it is estimated that it would be more practical to set two smaller platforms if onsite power generation is desired.

Commercial power plants located in Ventura County export power to other areas of the state. Since the proposed power cable will be connected to the electric grid system, the emissions caused by this additional power useage will have no significant effect on the Ventura County air basin.

Commercial power plants operate at an overall thermal efficiency of 90% and are more reliable than onsite generation.

The space requirements for a power cable installation with the necessary transformers and switchgear is much less than would be required for turbine generators. The disturbance to the ocean floor will be minimal because the cable is only 3.25" in diameter, and will be laid gently on the ocean floor and sink rapidly into the mud line. The cable will be installed in the same right-of-way as the pipelines.

B. Pipelines to New Onshore Site vs Pipeline
to Chevron's Platform Grace (Exhibit XVI-A)

The new onshore processing facility proposed by Union to handle production from the east end of the Santa Barbara channel has been designed to process oil, gas, and water from Platform Gilda. This site is ideally located to receive oil from Gilda, separate the oil and water, and ship the oil 2.5 miles through existing pipelines and/or expanded pipelines to Union's Marine terminal. Existing storage at the terminal will be utilized, and the oil will be shipped via an existing pipeline directly to the Los Angeles area. Separation of the oil and water will occur at the onshore facility where it can be done in an efficient manner using Best Available Control Technology. (The "Authority to Construct" has been issued by the Ventura County APCD for the onshore facilities as described in section XII.)

The Plan of Development for leases OCS P-0215, 0216 and 0217 in the Santa Clara Unit, submitted by Chevron U.S.A. Inc. discusses the various alternates for processing and transporting the production. The plan describes the facilities necessary to process and ship 28°API gravity oil produced from the Monterey formation through a new 12" pipeline to Chevron's existing facilities at Carpinteria. This plan considers only the Monterey production with minimal production from the Repetto formation.

From Platform Gilda both the Monterey and Repetto formations on OCS P-0216 will be developed. Tests indicate that the gravity of produced

oil will vary between 12° and 24°API and average approximately 20° API. The Plan of Development for Platform Gilda proposes a 10.75" O.D. gas pipeline and a 12.75" O.D. oil pipeline to a new onshore processing site at Mandalay Beach.

Disadvantages associated with shipping Platform Gilda production through the Platform Grace pipelines are as follows:

1. One additional platform would be required for treating facilities.
2. The pumping pressure necessary to move the total production from Platform Grace and Platform Gilda to Platform Hope would be 2300 psig which exceeds the maximum working pressure (1620 psig) of the pipeline.
3. The maximum production rate would exceed the capacity of the pipeline.
4. The 10" section of pipeline between Platform Hope and the Carpinteria onshore site could not handle the maximum production.
5. Additional facilities and storage would be required at Carpinteria.
6. Tanker loadings at Carpinteria would be increased by 200%.
7. Pipeline shipments from Carpinteria to a pipeline connection in Ventura would cause oil produced from P-0216 to be pumped approximately 40 additional miles.
8. The cost of building the treating facilities on a second offshore platform would increase the capital cost of the treating facilities by 1,000%.

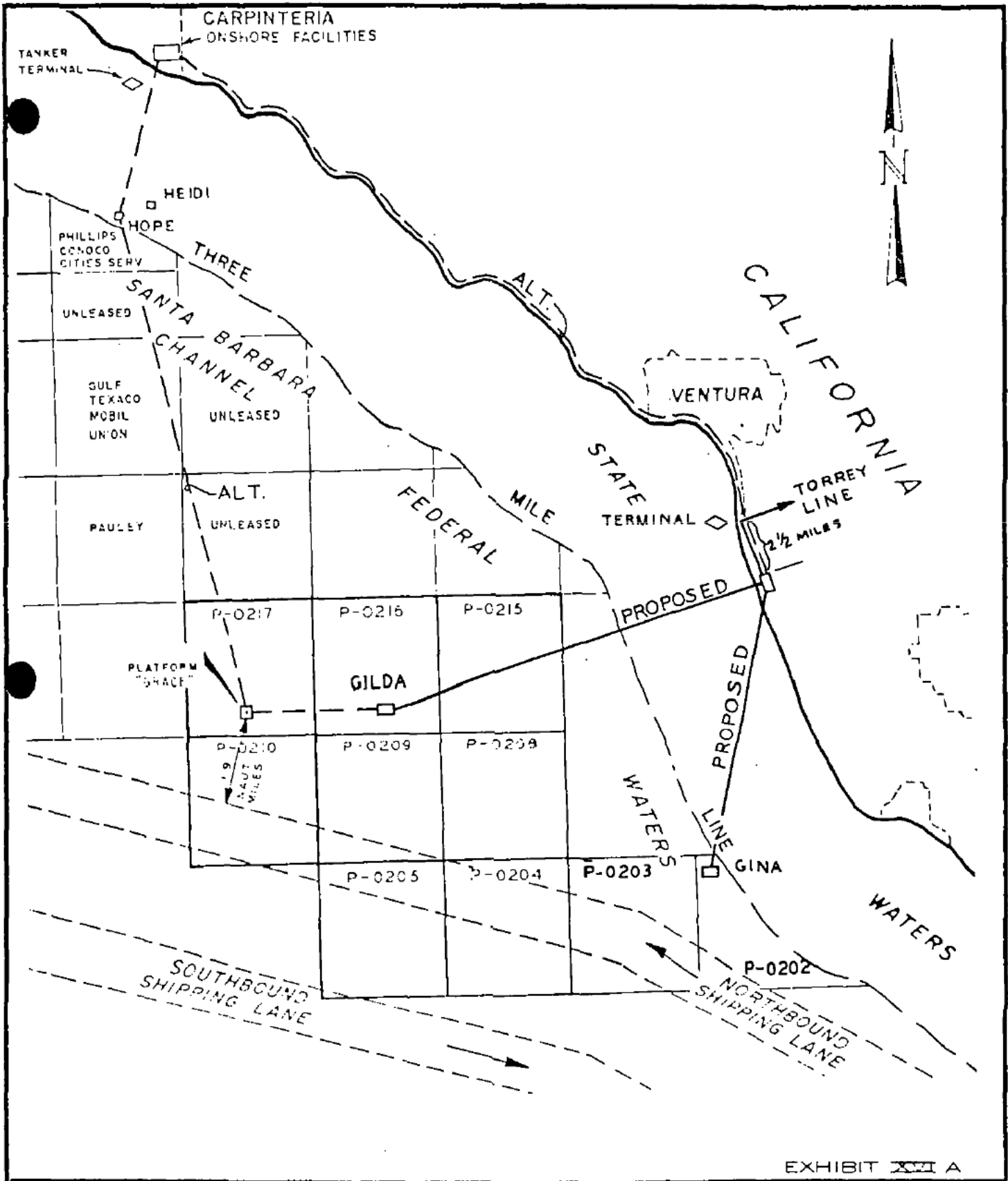

EXHIBIT XXI A

REV.	DATE

PROPOSED AND ALTERNATE PIPELINE ROUTES

DRAWN J.F. CKD. _____
 APPD. _____
 SCALE _____
 DATE _____

UNION OIL COMPANY OF CALIFORNIA

SHEETS 1 SHEET