

Appendix AA: Offshore Electric and Magnetic Field Assessment

Coastal Virginia Offshore Wind Commercial Project



Submitted by:
Dominion Energy Services, Inc.
707 E. Main Street,
Richmond, VA 23219

Prepared by:
Exponent, Inc.
17000 Science Drive, Suite 200
Bowie, MD 20715

Submitted to:
Bureau of Ocean Energy Management
45600 Woodland Road
Sterling, VA 20166

The assessment presented herein is consistent with the Project Design Envelope considered by Dominion Energy Virginia (Dominion Energy) prior to summer 2022. Due to maturation of the Coastal Virginia Offshore Wind Commercial Project (Project) design, Dominion Energy was able to refine several components of the Project and has subsequently revised the Construction and Operations Plan (COP) as re-submitted in February 2023. The primary changes are summarized as follows:

- The Maximum Layout includes up to 202 wind turbine generators (WTGs), with a maximum WTG capacity of 16 megawatts. As the Preferred Layout, Dominion Energy proposes to install a total of 176, 14.7-megawatt capacity WTGs with 7 additional positions identified as spare WTG locations. For both the Preferred Layout and Maximum Layout, the Offshore Substations will be within the WTG grid pattern oriented at 35 degrees and spaced approximately 0.75 nautical mile (1.39 kilometers) in an east-west direction and 0.93 nautical mile (1.72 kilometers) in a north-south direction.
- Removal of Interconnection Cable Route Options 2, 3, 4, and 5 from consideration. As the Preferred Interconnection Cable Route Option, Dominion Energy proposes to install Interconnection Cable Route Option 1.

The analysis presented in this appendix reflects the initial 205 WTG position layout as well as Interconnection Cable Route Options 1, 2, 3, 4, 5, and 6 as the maximum Project Design Envelope. Reduction in the Project Design Envelope is not anticipated to result in any additional impacts not previously considered in the COP. Therefore, in accordance with the Bureau of Ocean Energy Management's Draft Guidance Regarding the Use of a Project Design Envelope in a Construction and Operations Plan (2018), the appendix has not been revised. Additional details regarding evolution of the Project is provided in Section 2 of the COP and details regarding the full Project Design Envelope are provided in Section 3 of the COP.

Exponent®

*Electrical Engineering and Computer Science
Practice*

Ecological and Biological Sciences Practice

**Dominion Energy Coastal
Virginia Offshore Wind
Commercial Project**

**Offshore Electric and
Magnetic Field Assessment**



**Dominion Energy Coastal
Virginia Offshore Wind
Commercial Project**

**Offshore Electric and Magnetic
Field Assessment**

Prepared for

Dominion Energy Services, Inc.
707 E. Main Street
Richmond, VA 23219

Prepared by

Exponent
17000 Science Drive
Suite 200
Bowie, MD 20715

November 16, 2021

© Exponent, Inc.

Contents

	<u>Page</u>
List of Figures	iii
List of Tables	iv
Acronyms and Abbreviations	v
Limitations	vi
Executive Summary	vii
Introduction	1
Project Description	1
Magnetic Fields and Induced Electric Fields from the Project's Submarine Cables	2
Electric- and Magnetic-Field Guidelines for Human Exposure	3
Electric- and Magnetic-Field Exposure of Fish and Other Species in the Marine Environment	4
EMF Calculations	7
Buried and Covered Cables	7
Methods for EMF Cable Calculations	8
WTG and Offshore Substation Structures	8
Configurations of Cables at WTGs and Offshore Substations	8
EMF Calculation Results	13
Buried Project Cables	13
Project Cables at WTGs, Offshore Substations and Protected Segments	14
Description of Key Marine Communities in the Offshore Project Area	16
Sensitivity of Finfish to AC EMF	20
Electrosensitivity of Sturgeon Species	22
Sensitivity of Elasmobranchs to AC EMF	23
Sensitivity of Large Invertebrates to AC EMF	24
Evaluation of EMF Exposures from Project Cables	26
Assessment of Induced Electric-Field Effects on Electrosensitive Finfish and Elasmobranchs	27

Assessment of Chronic EMF Exposure to Marine Species at Offshore Substations, WTGs, and Protected Cables 28

Effects of Chronic AC EMF Exposures on Invertebrates and Finfish 28

Evaluation of Chronic EMF Exposure at Offshore Substations, WTGs, and Mattressed Areas 30

Conclusions 32

References 34

Attachment A Cable Configurations and Burial Depths

Attachment B Calculation Methods and Assumptions

Attachment C Calculated EMF Levels

Attachment D Calculated Volume-Averaged EMF Levels at Structures and Protective Coverings

List of Figures

	<u>Page</u>
Figure 1. Geographic location of the Offshore Project Area off the coast of Virginia (left), and its position east of Virginia Beach with the approximate path of the Offshore Export Cable Route Corridor (right).	2
Figure 2. Schematic exemplifying the geometry of a WTG with connecting Inter-Array Cables (green).	9
Figure 3. Schematic exemplifying the geometry of Inter-Array Cables (green) and Offshore Export Cables (brown) connecting to an Offshore Substation. The top figure illustrates cables traversing the east face of the jacket structure while the bottom figure shows cables traversing the south face of the jacket structure.	11

List of Tables

	<u>Page</u>
Table 1. Summary of calculated magnetic- and induced electric-field levels for 3.3-ft (1 m) burial depth and peak loading at specified horizontal distances*	14
Table 2. Maximum calculated volume-averaged magnetic fields (mG) and induced electric fields (mV/m) around the WTG, the Offshore Substations, and protected, surface-laid Offshore Export Cable	15
Table 3. Finfish species expected to inhabit the Offshore Project Area	16
Table 4. Elasmobranch species projected to inhabit the Offshore Project Area	17
Table 5. Large invertebrate species expected to inhabit the Offshore Project Area	19
Table 6. Calculated induced electric fields in sturgeon and dogfish models at the seabed and 3.3 ft (1 m) above the seabed for peak loading and a 3.3-ft (1 m) cable burial depth	27

Acronyms and Abbreviations

μ T	Microtesla
3D	3-dimensional
A	Ampere
AC	Alternating current
BOEM	Bureau of Ocean Energy Management
cm	Centimeter
CPS	Cable protection system
Dominion Energy	Dominion Energy Virginia
EMF	Electric and magnetic fields
Hz	Hertz
ICES	International Committee on Electromagnetic Safety
ICNIRP	International Commission on Non-Ionizing Radiation Protection
IEEE	Institute of Electrical and Electronics Engineers
in	Inch
km	Kilometer
kV	Kilovolt
Lease Area	Renewable Energy Lease Area OCS-A 0483
m	Meter
mG	Milligauss
mi	Mile
mm	Millimeter
MRE	Marine Renewable Energy
mT	Millitesla
mV/m	Millivolts per meter
MW	Megawatt
OCS	Outer Continental Shelf
OD	Outer diameter
Project	Coastal Virginia Offshore Wind Commercial Project
WTG	Wind turbine generator

Limitations

At the request of Tetra Tech, on behalf of the Virginia Electric and Power Company, doing business as Dominion Energy Virginia (Dominion Energy), Exponent modeled the alternating current electric- and magnetic-field levels associated with the operation of the submarine cables proposed for the Coastal Virginia Wind Commercial Project (the Project).

This report summarizes the analysis performed to date and presents the findings resulting from that work. In the analysis, we have relied on cable design geometry, usage, specifications, and various other types of information provided by Tetra Tech and Ramboll, the engineering company contracted by Dominion Energy to support development of the Project. We cannot verify the correctness of this input data and rely on Tetra Tech and Ramboll for the data's accuracy. Although Exponent has exercised usual and customary care in the conduct of this analysis, the responsibility for the design and operation of the Project remains fully with the client. Tetra Tech and Ramboll have confirmed to Exponent that the data contained herein are not subject to Critical Energy Infrastructure Information restrictions.

The analyses presented herein are made to a reasonable degree of engineering and scientific certainty. Exponent reserves the right to supplement this report and to expand or modify opinions based on review of additional material as it becomes available, through any additional work, or review of additional work performed by others.

The scope of services performed during this investigation may not adequately address the needs of other users of this report, and any re-use of this report or its findings, conclusions, or recommendations presented herein for purposes other than intended for project permitting are at the sole risk of the user. The opinions and comments formulated during this assessment are based on observations and information available at the time of the investigation. No guarantee or warranty as to future life or performance of any reviewed condition is expressed or implied.

Executive Summary

At the request of Tetra Tech, on behalf of the Virginia Electric and Power Company, doing business as Dominion Energy Virginia (Dominion Energy), Exponent calculated the alternating current electric and magnetic fields (EMF) associated with the operation of the Coastal Virginia Offshore Wind Commercial Project (the Project). Electricity generated by wind turbine generators (WTG) is carried by submarine Inter-Array Cables to Offshore Substations, and on submarine Offshore Export Cables running from the Offshore Substations to the Cable Landing Location in Virginia Beach, Virginia. EMF from the Inter-Array Cables and Offshore Export Cables buried beneath the seabed and in Trenchless Installation conduits near shore, where covered by protective coverings, and at interconnections with the WTGs and Offshore Substations were calculated for average and peak power flows. For purposes of this assessment, the Offshore Project Area is defined as the Offshore Export Cable Route Corridor where the Offshore Export Cables will be installed and the Lease Area where the Inter-Array Cables, WTGs, and Offshore Substations will be installed.

Transitory exposures to magnetic fields at the seabed above the buried cables were found to be at levels below reported thresholds for effects on the behavior of magnetosensitive marine organisms. The weak electric fields induced in seawater and in local electrosensitive marine organisms also were found to be below reported detection thresholds. Thus, the operating cables are not projected to affect the populations or distributions of fish in the Offshore Project Area.

Average EMF exposures of longer duration were calculated for small regions immediately surrounding the mattress- or rock-covered cables and at interconnection structures, where some fish species may spend more time. The magnetic-field strengths at the Offshore Substations and WTG structures averaged in a volume of water where some species would likely be present were calculated to be far below levels at which longer-term exposures have been reported to affect the physiology or behavior of some fish species. These conclusions are consistent with that of the U.S. Pacific Northwest National Laboratory's comprehensive review of the ecological impacts of Marine Renewable Energy development, which concluded that "there has been no evidence to show that EMFs at the levels expected from MRE [Marine Renewable Energy] devices will cause an effect (whether negative or positive) on any species" (Copping et al. 2016). New research summarized in a September 2020 update to this report is consistent with the conclusions of the 2016 report.

Note that this Executive Summary does not contain all of Exponent's technical evaluations, analyses, conclusions, and recommendations. Hence, the main body of this report is at all times the controlling document.

Introduction

Project Description

Dominion Energy Virginia (Dominion Energy), proposes to construct, own, and operate the Coastal Virginia Offshore Wind Commercial Project (hereafter referred to as the Project). The Wind Turbine Generators (WTG), Offshore Substations (OSS), and Inter-Array Cables (IAC) will be located in federal waters on the Outer Continental Shelf (OCS) in the designated Bureau of Ocean Energy Management (BOEM) Renewable Energy Lease Area OCS-A 0483 (Lease Area). The Lease Area is approximately 27 statute miles (mi) (23.5 nautical miles; 43.5 kilometers [km]) off the Virginia Beach coastline. The Offshore Export Cable Route Corridor between the Lease Area and the Cable Landing Location in Virginia Beach, Virginia, will be located in federal and Virginia state waters. The Onshore Project Components will be located in Virginia Beach and Chesapeake, Virginia. The Project is proposed to be comprised of up to 205 WTGs and will be capable of producing between 2,500 and 3,000 megawatts (MW) of alternating current (AC) electricity.¹

Electricity generated by WTGs at an operating voltage of 66 kilovolts (kV) will be conducted over approximately 300.7 mi (484 km) of Inter-Array Cables to three Offshore Substations. At the Offshore Substations, the voltage will be increased from 66 kV to an operating voltage of 230 kV for export to the Onshore Substation located in Chesapeake, Virginia. Electricity at 230 kV will be transmitted via three 3-core, 3-phase Offshore Export Cables from each Offshore Substation (for a total of nine Offshore Export Cables) to the Onshore Substation over a distance of approximately 42 mi (68 km).

To minimize interference with existing land uses at the Cable Landing Location and the State Military Reservation, the Offshore Export Cables will be installed underground via Trenchless Installation in the nearshore area. This area extends between the Offshore Trenchless Installation Punch-Out location, approximately 730 to 3280 feet (ft) (223 to 1000 meters [m]) offshore, to the Cable Landing Location, where the Offshore Export Cable is spliced and connected to the Onshore Export Cable in a duct bank. The Offshore Export Cables will be installed under the beach and dune in two Trenchless Installation

¹ The current Project follows on the completion of the Coastal Virginia Offshore Wind Pilot Project in July 2020. This partnership of Dominion Resources, Inc., and the Virginia Department of Mines, Minerals and Energy collected resource data and assessed the design, construction, installation, operation, and maintenance of two 6-MW turbines off the Virginia shore with funding from the U.S. Department of Energy. The Environmental Assessment by BOEM approved the Project with the finding that it posed no significant effect on the environment (BOEM 2015).

conduits with a minimum center-to-center spacing of 26 feet(ft) [8 meters (m)] between conduits. Further offshore, the minimum spacing between the Offshore Export Cables will be much greater (165 ft [50 m]). Figure 1 provides an overview of the Offshore Project Area with the proposed location of the WTG array and potential Offshore Export Cable route.

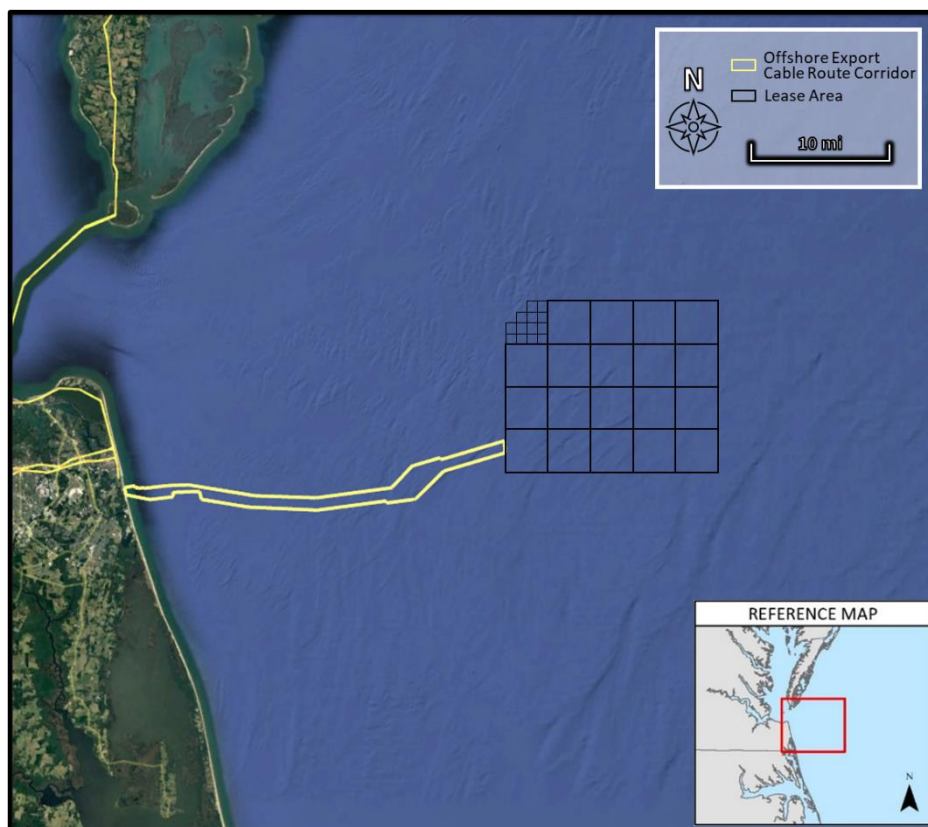

Figure 1. Geographic location of the Offshore Project Area off the coast of Virginia (left), and its position east of Virginia Beach with the approximate path of the Offshore Export Cable Route Corridor (right).

The Inter-Array and Offshore Export Cables—where buried or otherwise protected, at the WTGs, and at the Offshore Substations—will be sources of magnetic and induced electric fields, described in the following sections.

Magnetic Fields and Induced Electric Fields from the Project's Submarine Cables

The electricity produced by the Project WTGs will create EMF in the extremely low frequency range. The Project is designed to transmit (AC electricity from the WTGs at a frequency of 60 Hertz (Hz), meaning that the fields oscillate (i.e., change direction and intensity) 60 times per second, the same as AC electricity transmitted onshore on overhead distribution and transmission lines. Magnetic-field levels are typically reported in North America as magnetic flux density in units of Gauss or milligauss

(mG), where 1 Gauss is equal to 1,000 mG. In Europe and elsewhere, magnetic-field levels often are reported in units of microtesla (μT), where 1 mG is equal to 0.1 μT .

Magnetic fields will be produced by the flow of electric current in Project cables. The highest magnetic-field levels from the Project's buried submarine cables will be measured directly above the cables and will decrease rapidly with distance. Electric fields that are produced by the voltage applied to electrical conductors of the Inter-Array Cables and Offshore Export Cables are effectively blocked from the marine environment by the metallic sheaths and steel armoring of the cable (Snyder et al. 2019).

Although the electric field produced by voltage impressed on the cable conductors will not be present outside the cables, the magnetic field will induce a weak electric field in the seawater around the cables and in nearby marine species. Induced electric-field levels are typically measured in units of millivolts per meter (mV/m), and similar to magnetic fields, they decrease rapidly with distance from the source.

The load current—expressed in units of amperes (A)—carried on the cables changes with the speed of the wind. Since both magnetic fields and induced electric fields are created by the current carried on the cables, these levels will also vary over time, and therefore measurements or calculations of these fields represent only a conditional snapshot. Calculations of magnetic and induced electric fields in this report were performed for both estimated annual average load and peak load to account for this variability, providing a portrait of the maximum (conservative) field levels expected and the more typical levels for average operating conditions.

Electric- and Magnetic-Field Guidelines for Human Exposure

Neither the federal government nor the Commonwealth of Virginia has enacted any laws or regulations to limit the electric fields or magnetic fields from above ground, buried, or submarine transmission or distribution cables, or from other infrastructure related to the transmission of electricity at a frequency of 60 Hz. Since the majority of the Project's electrical infrastructure will be offshore, human exposure to EMF from the Project's cables will be limited to examples such as scuba divers in close proximity to the cable routes.

Although exposure to EMF from the Project will be limited, it is important to consider guidance from two international organizations regarding human exposure to magnetic fields.² The International

² The limits for both ICES and ICNIRP for electric-field exposure are roughly one million times higher than those expected from induced electric fields, so human exposure to electric fields is not discussed further in this report.

Commission on Non-Ionizing Radiation Protection (ICNIRP) and the International Committee on Electromagnetic Safety (ICES) provide guidance based on extensive review of relevant research on the health and safety of exposure to magnetic fields. Subsequent to their ongoing review and evaluation of this research, these organizations propose limits for both occupational exposure and exposure of the general public that is designed to protect health and safety of humans. ICNIRP is an independent, non-profit scientific organization, which is "... formally recognized as an official collaborating non-state actor by the World Health Organization and the International Labour Organization," and is "linked to many organizations engaged in NIR [non-ionizing radiation] protection worldwide through diverse collaborative projects."³ ICES is an organization that operates under the oversight of the Institute of Electrical and Electronics Engineers (IEEE) Standards Association Board, and is "... responsible for development of standards for the safe use of electromagnetic energy in the range of 0 Hz to 300 GHz [Gigahertz] ..."⁴ The ICNIRP reference level limit for 60-Hz magnetic fields is 2,000 mG for the general public (ICNIRP 2010), while the ICES reference level limit for the general public is 9,040 mG (ICES 2019).

Electric- and Magnetic-Field Exposure of Fish and Other Species in the Marine Environment

Fish and other marine organisms may experience both transitory and longer-term exposure to magnetic and induced electric fields from the Project's cables and infrastructure. This was evaluated in detail because some species of environmental and ecological importance have been studied for decades because they have specialized sensory receptors capable of detecting magnetic fields or electric fields, or both, in the natural environment (e.g., Taylor 1986; Klimley 1993; Lohmann et al. 1995; Hellinger and Hoffmann 2012). Research has determined that the magnetic and induced electric fields that generally can be detected by fish and other marine organisms fall in a very limited range of frequencies, approximately 0 Hz (i.e., the frequency of the earth's static geomagnetic field) to approximately 10 Hz (Bedore and Kajiura 2013; Snyder et al. 2019). The evaluation below addresses both potential short-term and longer-term exposures of fish and other species of interest in the Offshore Project Area.

Transitory Exposure

Demersal fish species (located on or near the seafloor) will experience transitory exposure to magnetic and induced electric fields from the Project's cables as they swim over buried cables. The assessment in

³ <https://www.icnirp.org/en/about-icnirp/aim-status-history/index.html>

⁴ <http://www.ices-emfsafety.org/>

the sections below, therefore, focused on the capability of species potential to detect these fields, and if detected, whether they are likely to result in: 1) individual behavioral effects, 2) individual physiological effects, or 3) population-level effects from exposure in the Offshore Project Area.

Magnetic-field and induced electric-field levels associated with the submarine cables were calculated at a height of 3.3 ft (1 m) above the seabed as relevant reference locations where most demersal marine species are found.⁵ The calculated field levels were compared to the detection thresholds of various marine species expected to be in the Offshore Project Area (e.g., elasmobranchs; finfish; and large crustaceans, such as crabs and lobsters) to assess the likelihood of detection or alteration of animal behavior.

Longer Duration Exposure at Structures and Protective Coverings

While most marine species will experience only transitory exposure from the Project's cables, some may be attracted to the hard-surface structures associated with the Offshore Project Components, which may provide an attractive habitat in an area where hard-surface structures are sparse. At WTG and Offshore Substation structures where the Inter-Array Cables and Offshore Export Cables emerge from the seabed to connect to these structures, they are not buried and the cables are brought closer together where they enter these structures. At some other locations, short segments of unburied cable ((because of physical obstructions in the seabed) covered by hard surfaces of protective rock or mattress also may attract some species that prefer hard-surfaces. There, the magnetic-field and induced electric-field levels also will be higher, as the coverings may not achieve the same depth of cover as the seabed provides for most of the route.. These protective coverings may attract some demersal species, regardless of the presence of magnetic and induced electric fields.

Since these new habitats may encourage certain fish and shark species to spend a greater amount of time relatively close to these structures, and they would be expected to move freely throughout the environment around these structures from top to bottom, a conservative estimate of average exposure to EMF over a medium term (hours, days) was calculated for the average level in volumes of the water column adjacent to these structures or above the mattress-protected cables. In the case of the WTG, Inter-Array Cables are installed inside the monopile and so exposures were evaluated where the cables exit near the base of the monopile. At the OSS where the power cables are contained inside J-tubes (J-shaped metal conduits for Project Cables), two evaluation volumes were considered based on the

⁵ This height is consistent with recommendations in international exposure assessments (e.g., ICES 2019; ICNIRP 2010) and is meant to capture species swimming in close proximity to the seabed.

configuration of cables and on species which might inhabit the two different areas. The first evaluation volume is near the structure base and the second evaluation volume is higher in the water column. Each of these evaluation volumes were defined for both the east and south faces of the jacket structure. Details of the WTG and Offshore Substation evaluation volumes are provided in Attachment D. The average field levels corresponding to these volumes were compared to field levels reported in the scientific literature where physiologic responses were measured over longer periods than are typically used for acute behavioral studies.

EMF Calculations

Buried and Covered Cables

Exponent calculated the 60-Hz fields from the three phase, 3-core submarine cables proposed for different portions of the Project and compared the calculated levels to assessment criteria to evaluate potential effects on marine species. Five representative cable configurations were modeled to represent the various offshore cables and installation methods including:

- Inter-Array Cables
 1. At a burial depth of 3.3 ft (1 m), and
 2. Where installed at the seabed with a 1-ft (0.325-m) thick protective covering.^{6,7}
- Offshore Export Cables
 1. At a burial depth of 3.3 feet (1 m),
 2. Where installed at the seabed with a 1-ft (0.325-m) thick protective covering and a 165-foot separation distance, and
 3. As a set of nine parallel cables where installed in Trenchless Installation conduits in the nearshore area, with 26 ft (8 m) center-to-center separation between Trenchless Installation conduits and buried 3.3 ft (1 m) beneath the seabed. Near the Offshore Trenchless Installation Punch-Out, the aluminum core Offshore Export Cables from the OSS will transition at a bimetallic joint to the copper conductor type Offshore Export Cables that will traverse the remaining distance in the Trenchless Installation conduits to the transition bay at the Cable Landing Location.⁸

The project design envelope (See Coastal Virginia Offshore Wind Commercial Construction and Operations Plan, Section 3, Description of Proposed Activity) describes burial depths ranging from 3.3 ft to 16.4 ft (1 to 5 m) beneath the seabed; however, here all calculations are presented at a 3.3 ft (1 m)

⁶ Exponent understands that only Offshore Export Cables are expected to require mattress-covered portions along the Offshore Substations to Onshore Substation routes where cable crossings of other submarine cables may occur. However, results for mattress-covered Inter-Array Cables also were calculated and presented herein.

⁷ The design of the Inter-Array Cables has been updated to smaller cables with less current compared to the original assessment performed by Exponent. Since the original design will produce higher field levels, modeling of an isolated Inter-Array Cable has not been updated. Details of both the original design and the new design are summarized in Attachment A.

⁸ The Project Cables in Trenchless Installation conduits are expected to be installed at burial depths well in excess of 3.3 ft (1 m), except at the seaward end of the Trenchless Installation (i.e., at Punch-Out). The burial depth and cable spacing used here is intended to conservatively overestimate fields for the entire Trenchless Installation route.

burial depth to conservatively overestimate EMF levels from cables buried to greater depths. Details of the modeled cable configurations are provided in Attachment A, Table A-1.

Methods for EMF Cable Calculations

Exponent modeled the magnetic- and induced electric-field levels for each cable configuration with 3-dimensional (3D) finite element analysis (FEA) software using conservative assumptions designed to ensure that the calculated levels overestimate the field levels that would be measured above the cables at any specified loading within the range of the Project's capacity. The calculated AC fields are presented at maximum loading (i.e., peak loading, which is the maximum Project capacity) and at the anticipated typical Project loading (i.e., average loading). Where cables are expected to be separated from one another by sufficiently large distances such that they are not expected to interact, models were created to calculate magnetic fields produced by an individual Inter-Array Cable and an individual Offshore Export Cable. These calculations are reported both at the seabed and at 3.3 ft (1 m) above the seabed. Where the nine Offshore Export Cables are installed in Trenchless Installation conduits, an additional modeling geometry incorporated a set of three Offshore Export Cables to capture any potential additive effects of magnetic fields from adjacent cable in Trenchless Installation conduits at a minimum separation distance. Additional details of modeling assumptions and methods are presented in Attachment B, and results of the calculations are presented in Attachment C.

WTG and Offshore Substation Structures

Configurations of Cables at WTGs and Offshore Substations

Exponent modeled magnetic- and induced electric-field levels from the WTGs supported on monopile foundations, and Offshore Substations supported on piled jacket foundations. The WTGs and Offshore Substations will have the various Inter-Array Cables and Offshore Export Cables distributed around the perimeter of the foundations. In all cases, modeling was based upon the configurations of cables and scenarios accounting for the minimum separation between adjacent cables and also for the minimum separation between cables and the marine environment (resulting in the maximum field exposure scenarios). Details of the WTG and Offshore Substation modeling geometry are provided in Attachment A and calculation results are provided in Attachment D.

WTG Model

The 3D model of the WTG foundation includes a central cylindrical pillar, within which three Inter-Array Cables traverse vertically through the water column before exiting at an angle of 45 degrees from vertical at a height of 6.6 ft (2 m) above the scour protection at the base of the monopile. The Inter-Array Cables were modeled to be contained inside of a cable protection system (CPS) as they leave the monopile, and then were assumed to travel along the top of the scour protection, radially away from the WTG structure in a horizontal direction. An illustrative example of the modeling configuration is shown in Figure 2. Further details of the WTG foundation geometry are shown in Attachment A (Figure A-2) and the results of field level calculations are included in Attachment D (Figure D-2).⁹

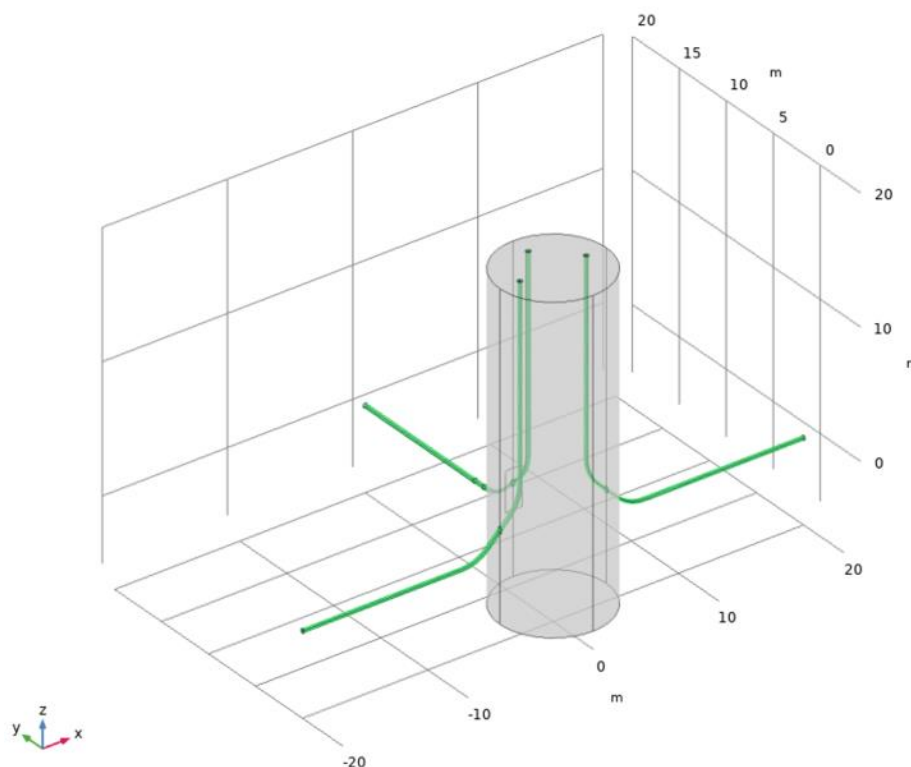

Figure 2. Schematic exemplifying the geometry of a WTG with connecting Inter-Array Cables (green).

⁹ The designs of the WTG and Inter-Array Cables were updated after Exponent evaluated the original design. Since the latest designs will produce lower field levels than the original designs for the WTGs and Inter-Array cables, the original modeling has not been updated. Details of both the original design and the new design are summarized in Attachment D for the WTG and Attachment A for the Inter-Array Cables.

Offshore Substation Model

The Offshore Substation foundation configuration consists of a lattice structure with Inter-Array Cables and Offshore Export Cables distributed around a platform with a rectangular cross-section. The perimeter of the structure, along which J-tubes are lined, is approximately 66 ft by 89 ft (20 m by 27 m) at the Offshore Substation platform, expanding in all directions to approximately 92 ft by 118 ft (28 m by 36 m) at the seabed. Each cable is contained in an individual J-tube. The J-tubes run down the edge of the surface created by connecting the perimeters of these two rectangles. The J-tubes are distributed along the east, south, and north edges (i.e., faces) of the rectangular jacket structure with a minimum center-to-center J-tube separation of approximately 7.2 ft (2.2 m). The geometry of the configuration was assumed for very conservative modeling scenario, where all J-tubes contain active cables.

Figure 3 depicts the geometry of the 3D model used for the Offshore Substation foundation. The east and south faces of the jacket foundation were modeled as they were expected to yield the highest magnetic- and induced electric-field exposures. The south face contains five J-tubes: four J-tubes to accommodate Export cables and one J-tube to contain an Inter-Array Cable. The east and north faces both contain six J-tubes for Inter-Array cables. However, since the J-tubes on the north face are distributed over a larger distance, the average magnetic and induced electric fields on the north face will be lower than the corresponding values for the east face. The geometry corresponding to the east face of the Substation's jacket foundation is shown in the top figure while the south face geometry is illustrated in the bottom figure. For both the east and south faces of the jacket foundation, cables exit J-tubes at a height of 8.2 ft (2.5 m) above the seabed. Further details of the OSS geometry are shown in Attachment A, and details of modeling assumptions and methods are discussed in Attachment B. Calculation results are provided in Attachment D.

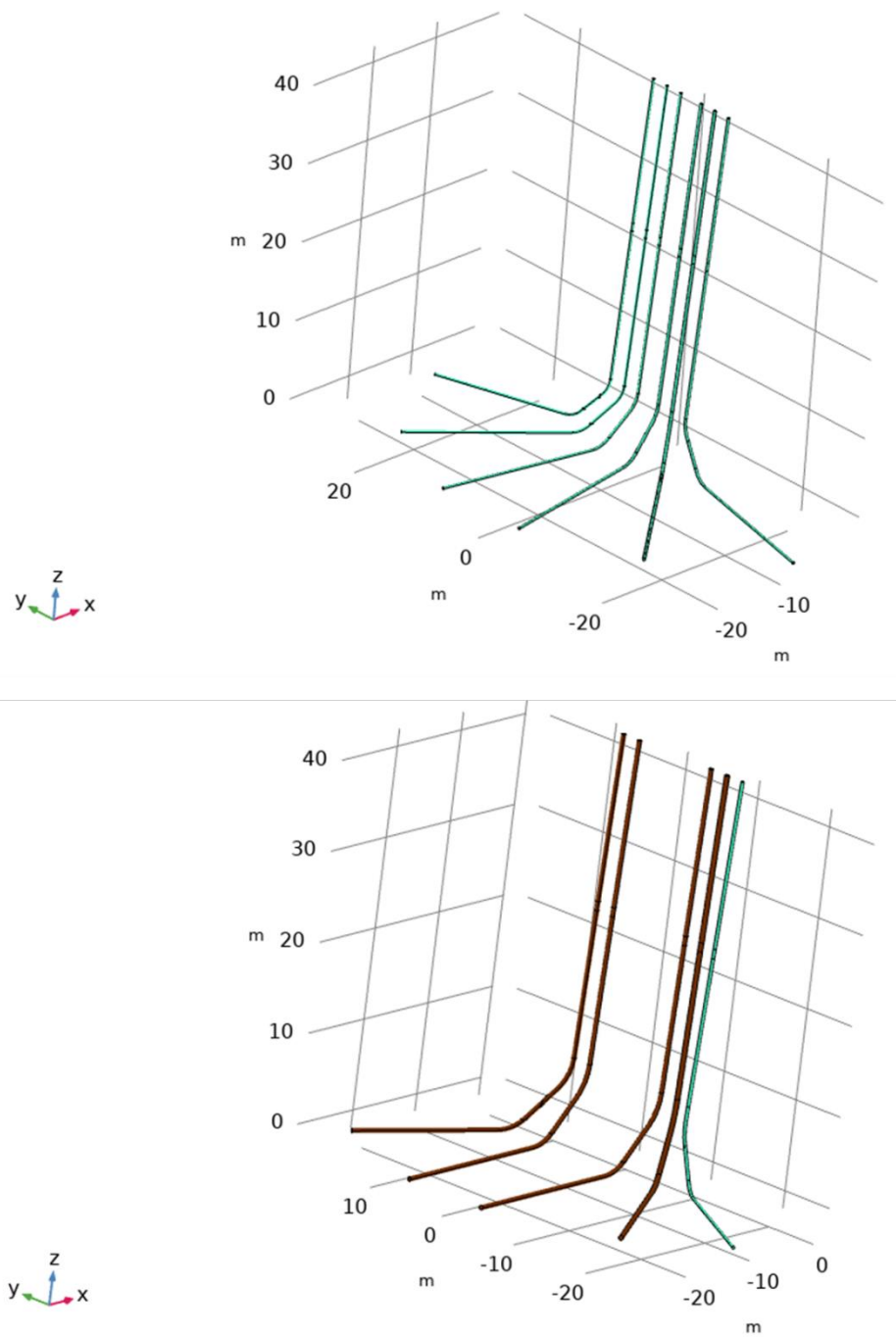

Figure 3. Schematic exemplifying the geometry of Inter-Array Cables (green) and Offshore Export Cables (brown) connecting to an Offshore Substation. The top figure illustrates cables traversing the east face of the jacket structure while the bottom figure shows cables traversing the south face of the jacket structure.

EMF Calculation Methods for WTG and Offshore Substation Models

Calculations for the WTGs and Offshore Substations were performed using the same methods that were used to model the EMF from the Inter-Array Cables and Offshore Export Cables, including modeling assumptions designed to provide conservative upper bounds on the expected field levels surrounding the structures. Exponent calculated magnetic and induced electric fields throughout the entire volume of the 3D model, and field strengths were reported as volumetric averages evaluated over regions of interest for marine species.

EMF Calculation Results

Where cables are buried, the assessment has focused on the detection of the maximum magnetic fields and induced electric fields over the cables by sensitive marine species. In contrast, where Offshore Project Components may introduce new habitat (i.e., Offshore Substations, WTGs, and protective cable coverings) the assessment focused on the potential for physiological effects from longer-term exposures to higher average fields around these structures.

Buried Project Cables

At peak loading and where cables are buried to a depth of 3.3 ft (1 m), the maximum calculated magnetic field at the seabed was 68 mG for the 66-kV Inter-Array Cables¹⁰ and 112 mG for 230-kV Offshore Export Cables in direct buried and Trenchless Installation configurations. The maximum electric fields induced in seawater at the seabed, for cables buried to a depth of 3.3 ft (1 m), were 1.1 mV/m for the 66-kV Inter-Array Cable and 1.9 mV/m for the 230-kV Offshore Export Cables. Magnetic- and induced electric-field levels decrease rapidly with distance as shown below in Table 1. Detailed results for the modeled configurations are provided in Attachment C. Magnetic-field calculations are presented in Tables C-1 and C-2, Figures C-4 to C-6, and Figures C-10 to C-12. Electric-field calculations are presented in Tables C-3 and C-4, Figures C-7 to C-9, and Figures C-13 to C-15.¹¹

¹⁰ Exponent understands that revisions to the Project design specify IAC with reduced cable cross-sectional dimensions and loading. As the latest IAC modeling parameters used for the field assessment produced lower field levels than the original configurations and loadings, the results of the previous assessment are referenced here to represent a very conservative estimate of magnetic- and induced electric-field values for operation of the IAC.

¹¹ Exponent understands that the United States Navy has expressed interest in EMF levels associated with the Offshore Project cables related to United States Navy subsea assets as well as training or testing activities near the Offshore Project Area. It is Exponent's understanding that coordination between Dominion Energy and the Navy is ongoing and Exponent will assist in evaluating and resolving any specific topics as needed.

Table 1. Summary of calculated magnetic- and induced electric-field levels for 3.3-ft (1 m) burial depth and peak loading at specified horizontal distances*

Cable Configuration	Evaluation Height	Magnetic Field (mG)			Electric Field (mV/m) [†]		
		Max	±5 ft (±1.5 m)	±10 ft (±3 m)	Max	±5 ft (±1.5 m)	±10 ft (±3 m)
Inter-Array Cable	At the seabed	68	8.8	0.4	1.1	0.2	<0.1
	3.3 ft (1 m) above the seabed	5.2	1.6	0.1	0.10	<0.1	<0.1
Offshore Export Cable	At the seabed	112	15	0.7	1.9	0.3	<0.1
	3.3 ft (1 m) above the seabed	8.7	2.7	0.2	0.2	0.1	<0.1
Offshore Export Cable: Trenchless Installation [§]	At the seabed	112	16	0.7	1.9	0.3	<0.1
	3.3 ft (1 m) above the seabed	8.7	2.8	0.3	0.2	0.1	<0.1

* For the individual Inter-Array and Offshore Export Cables, the horizontal distance is measured from the centerline of the cable. For the Offshore Export Cables in the Trenchless Installation configuration the maximum is measured over the middle cable, and the horizontal distance is measured from the center of the right-side or left-side cable, for distances > 0 ft and < 0 ft, respectively.

[†] Induced electric fields in representative marine species of interest are lower than those presented here for induced electric fields in seawater.

[§] The Offshore Export Cables in Trenchless Installation conduits are modeled with a burial depth of 3.3 ft (1 m) to the top of the cable, providing a conservative estimate of field values. The actual burial depth of the Trenchless Installation conduits will be 82 to 98 ft (25 to 30 m). At this burial depth, calculated field levels, even directly above the cable will be much less than 0.1 mG and 0.1 mV/m, and close to background levels.

Project Cables at WTGs, Offshore Substations and Protected Segments

The maximum volume-averaged magnetic-field and induced electric-field levels around the project elements that may serve as new habitat was 256 mG and 2.70 mV/m, respectively. This corresponds to a location in the water column on the east face of the Offshore Substation. The maximum volume-averaged magnetic-field and induced electric-field levels around the project elements that may serve as new habitat near the seabed was 209 mG and 2.51 mV/m, respectively. Volume-averaged magnetic- and induced electric-field levels above the Offshore Export Cables that are laid on the seabed and installed with protective coverings are similar—185 mG and 2.65 mV/m, respectively—while at the WTG, field levels are lower—120 mG and 1.28 mV/m, respectively. Volume-average field levels are summarized in Table 2 below, with additional details regarding the models, definitions of the precise volumes over which averaging was performed, and calculation results in Attachment D.

Table 2. Maximum calculated volume-averaged magnetic fields (mG) and induced electric fields (mV/m) around the WTG, the Offshore Substations, and protected, surface-laid Offshore Export Cable

Project Element (Volume of Water)	Maximum volume-averaged calculations	
	AC Magnetic-Field (mG)	AC Electric Field (mV/m)
WTG (Inter-Array Cables at the skirt)	120	1.28
Offshore Substation (east-face water column)	256	2.70
Offshore Substation (south-face at base)	209	2.51
Protected Offshore Export Cable (above the covered cable)	243	3.48

Field levels, both above buried cables and at structures, decrease very quickly with distance from the cables, so the calculations summarized above are applicable only in the immediate vicinity of the Project cables (both individually and at structures) which represents approximately one percent of the total marine habitat in the Offshore Project Area. Field levels will be higher where cables are covered with protective materials compared to buried cables; but consistent with the observations of Snyder et al. (2019), field levels for either buried cables or where cables are covered with protective materials are similar, and levels for both scenarios are low within approximately 10 ft (3 m) of the cable.

Description of Key Marine Communities in the Offshore Project Area

As noted, the Project will be sited approximately 27 mi (43.5 km) off the coastline of Virginia Beach, Virginia, east of the entrance to Chesapeake Bay. Project cables are expected to be routed through habitats of a number of different commercially, recreationally, and ecologically important marine species. These include large invertebrate species, finfish, and elasmobranchs.

Key finfish¹² species expected to inhabit the Offshore Project Area are listed in Table 3. The likelihood and frequency of fish encountering the magnetic and induced electric fields produced by subsea cables is influenced by the behaviors and preferred habitats of the different species. For instance, Bull and Helix (2011) have suggested that demersal (bottom-dwelling) fish species are most likely to be exposed to EMF from submarine cables because they inhabit the portion of the water column closest to the cables. Pelagic fish species (those that inhabit the upper parts of the water column), however, will be more distant from the cable route, and therefore less likely to experience exposure from submarine cables.

Table 3. Finfish species expected to inhabit the Offshore Project Area

Species	Demersal or Pelagic?	Size at first reproduction (centimeters [cm])*	Common length (cm)*
Albacore tuna (<i>Thunnus alalunga</i>)	Pelagic	85	100
Atlantic butterfish (<i>Peprilus triacanthus</i>)	Pelagic/Benthopelagic	12	20
Atlantic herring (<i>Clupea harengus</i>)	Pelagic	17	30
Atlantic mackerel (<i>Scomber scombrus</i>)	Pelagic	29	30
Atlantic sturgeon (<i>Acipenser oxyrinchus oxyrinchus</i>)	Demersal	183	250
Bigeye tuna (<i>Thunnus obesus</i>)	Pelagic		
Black sea bass (<i>Centropristis striata</i>)	Reef-associated	19.1	30
Blue marlin (<i>Makaira nigricans</i>)	Pelagic		290
Bluefin tuna (<i>Thunnus thynnus</i>)	Pelagic	97	200
Bluefish (<i>Pomatomus saltatrix</i>)	Pelagic	30	60
Longbill spearfish (<i>Tetrapturus pfluegeri</i>)	Pelagic		165
Monkfish (<i>Lophius americanus</i>)	Demersal/Benthic	47	90
Ocean pout (<i>Zoarces americanus</i>)		28.8	110 (max length)

¹² The term finfish is used to distinguish these species from the elasmobranchs

Species	Demersal or Pelagic?	Size at first reproduction (centimeters [cm])*	Common length (cm)*
Offshore Hake (<i>Merluccius albidus</i>)	Demersal	28	30
Red hake (<i>Urophycis chuss</i>)	Demersal/Benthic	26	
Roundscale spearfish (<i>Tetrapturus georgii</i>)	Pelagic		
Sailfish (<i>Istiophorus platypterus</i>)	Pelagic	150	270
Scup (<i>Stenotomus chrysops</i>)	Demersal/Benthic	16	25
Silver hake (<i>Merluccius bilinearis</i>)	Demersal/Benthic	23	37
Skipjack tuna (<i>Katsuwonus pelamis</i>)	Pelagic	40	80
Summer flounder (<i>Paralichthys dentatus</i>)	Demersal/Benthic	28	
Swordfish (<i>Xiphias gladius</i>)	Pelagic	156	300
White hake (<i>Urophycis tenuis</i>)	Demersal/Benthic	46	70
White marlin (<i>Kajikia albida</i>)	Pelagic	130	210
Windowpane flounder (<i>Scophthalmus aquosus</i>)	Demersal/Benthic	22	
Winter flounder (<i>Pseudopleuronectes americanus</i>)	Demersal/Benthic	27	
Yellowfin tuna (<i>Thunnus albacares</i>)	Pelagic	103	150
Yellowtail flounder (<i>e</i>)	Demersal/Benthic	30	

* Information from fishbase.org (all sizes in centimeters)

In addition to finfish species, elasmobranchs, including skates, sharks, dogfish, and rays are common inhabitants of the Offshore Project Area and the United States Atlantic coast. In contrast to finfish, these species are characterized by cartilaginous skeletons. Nearly 30 different shark, skate, and dogfish species are expected to inhabit parts of the proposed Offshore Project Area at some point in the year (Table 4). Certain species, however, exhibit large ranges throughout both shallow coastal environments and deep oceanic waters and it is therefore the Offshore Project Area constitutes only a very minor portion of the total range. Smaller benthic elasmobranchs like skates and dogfish have small ranges within coastal areas and inhabit soft sediment sea bottoms. As such, these small demersal species are more likely to frequently encounter cable routes.

Table 4. Elasmobranch species projected to inhabit the Offshore Project Area

Species	Demersal or Pelagic	Size at first reproduction, (cm)*	Common length (cm)*
Basking Shark (<i>Cetorhinus maximus</i>)	Pelagic	500	700
Atlantic Angel Shark (<i>Squatina dumeril</i>)	Demersal	92	100
Atlantic Sharpnose Shark (<i>Rhizoprionodon terraenovae</i>)	Demersal	85	

Species	Demersal or Pelagic	Size at first reproduction, (cm)*	Common length (cm)*
Barndoor skate (<i>Dipturus laevis</i>)	Demersal		
Bigeye Thresher Shark (<i>Alopias superciliosus</i>)	Pelagic	154	350
Blacknose shark (<i>Carcharhinus acronotus</i>)	Reef-associated	115	
Blacktip shark (<i>Carcharhinus limbatus</i>)	Reef-associated	120	150
Blue Shark (<i>Prionace glauca</i>)	Pelagic	206	335
Clearnose skate (<i>Rostroraja eglanteria</i>)	Demersal	49	
Common Thresher Shark (<i>Alopias vulpinus</i>)	Pelagic	303	450
Dusky Shark (<i>Carcharhinus obscurus</i>)	Pelagic	220	250
Little Skate (<i>Leucoraja erinacea</i>)	Demersal/ Benthic	32	
Longfin mako (<i>Isurus paucus</i>)	Pelagic		200
Night shark (<i>Carcharhinus signatus</i>)	Benthopelagic	150	200
Oceanic whitetip shark (<i>Carcharhinus longimanus</i>)	Pelagic	180	270
Rosette skate (<i>Leucoraja garmani</i>)	Reef-associated	34	
Sand Tiger Shark (<i>Carcharias Taurus</i>)	Pelagic	220	250
Sandbar Shark (<i>Carcharhinus plumbeus</i>)	Benthopelagic	126	200
Scalloped Hammerhead Shark (<i>Sphyrna lewini</i>)	Pelagic	140	360
Shortfin Mako Shark (<i>Isurus oxyrinchus</i>)	Pelagic	278	270
Silky shark (<i>Carcharhinus falciformis</i>)	Reef-associated	228	250
Smoothhound shark (<i>Mustelus mustelus</i>)	Demersal	80	100
Spinner shark (<i>Carcharhinus brevipinna</i>)	Reef-associated	210	250
Spiny Dogfish (<i>Squalus acanthias</i>)	Demersal/ Benthic	81	100
Thorny skate (<i>Amblyraja radiata</i>)	Demersal	87.5	
Tiger Shark (<i>Galeocerdo cuvieri</i>)	Pelagic/ Benthopelagic	210	500
Winter Skate (<i>Leucoraja ocellata</i>)	Demersal/ Benthic	73	

* Information from fishbase.org (all sizes in centimeters)

Resident large invertebrate species in the Offshore Project Area include epibenthic crustaceans, bivalves, and squid. These include two species of commercially harvested squid—longfin squid and northern shortfin squid (Table 5), which are schooling migratory species. Similarly, large mobile crustacean species like crabs and lobsters are expected to live and migrate through the Offshore Project Area, and as a result of these species' wide range and benthic habits, they are expected to occasionally move through the proposed cable routes. In addition to these mobile species, there are also less mobile or sessile invertebrate species that are expected to occur in the Offshore Project Area, including various bivalves, such as the Atlantic sea scallop, the Atlantic surf clam, and the quahog clam. However, these species

lack of mobility mean that the risk of exposure to Project cables for these species is low, unless located within the Offshore Export Cable Route Corridor.

Table 5. Large invertebrate species expected to inhabit the Offshore Project Area

Species	Preferred Habitat
Atlantic sea scallop (<i>Placopecten magellanicus</i>)	Associated with sand, gravel, shells, and other rocky habitats
Atlantic surfclam (<i>Spisula solidissima</i>)	Burrows in medium-grained sand and finer substrates usually at depths between 26 to 216 ft (8 to 66 m)
Whelk (locally 'conch') (Busyconinae)	Associated with sandy sediments or habitat structure in nearshore and offshore waters
Deep-sea crab (<i>Chaceon quinquegens</i>)	Generally associated with silty sediments at depths >328 ft (100 m); occasionally at depths as shallow as 130 ft (40 m) in the northern end of their range
Longfin inshore squid (<i>Doryteuthis pealeii</i>)	Benthopelagic in inshore areas and to the Outer Continental Shelf
Northern shortfin squid (<i>Illex illecebrosus</i>)	Found over various bottom substrates from coastal areas throughout the Continental Shelf
Ocean quahog (<i>Arctica islandica</i>)	Sandy substrates, generally at depths between 82 and 200 ft (25 and 61 m)

Sensitivity of Finfish to AC EMF

Multiple fish species have been observed to have sensory mechanisms that are believed to allow them to detect changes in the geomagnetic field. These mechanisms include particles of a magnetic substance, magnetite, embedded in fish bones and organs (Harrison et al. 2002). Tuna, carp, salmonids, eels, and other fish species are thus capable of detecting and responding to variations in the geomagnetic field and can use these as migratory cues (Hanson and Westerberg 1987; Walker et al. 1998; Tański et al. 2011). However, geomagnetic sense is used together with other sensory stimuli, including photoperiod, changes in temperature and currents, and olfactory cues. Unlike magnetosensitivity, only a select few fish species are known to be able to detect naturally-occurring electric fields. Electrosensitivity is an ability that is facilitated by specialized electroreceptors called ampullae of Lorenzini. Electrosensitive fish that reside in the Offshore Project Area are sturgeon species (family Acipenseridae); these are endangered anadromous fish that seasonally reside in estuaries and coastal environments. Sturgeons use electric signals to detect prey items, which generate low-level, low-frequency electric fields over small distances. The sensitivity of finfish species to magnetic fields produced by 50- or 60-Hz transmission cables was evaluated by review of information from laboratory and field studies. Given that the ability to detect magnetic fields evolved across multiple species of fish in response to a common environmental cue (the earth's geomagnetic field), it is expected that both the types of response behaviors and field strengths that are detectable by fish will be largely conserved across various species.

Overall, information from available laboratory studies on the effects of 50- or 60-Hz EMF on fish behavior indicate a lack of evidence for significant effects on fish behavior. Richardson et al. (1976) performed an early study that examined the effects of exposure to 60- to 75-Hz magnetic fields on magnetosensitive Atlantic salmon (*Salmo salar*) and American eel (*Anguilla rostrata*). Exposure to a 500 mG magnetic field did not alter swimming behaviors in either species of fish, leading the authors to conclude that 60-Hz AC magnetic fields are either undetectable or do not affect the behavior of these migratory fish (Richardson et al. 1976). The conclusion has been supported by more recent studies conducted with similar species by the Marine Scotland Science Agency (Armstrong et al. 2015; Orpwood et al. 2015). These researchers examined the responses of European eel (*A. anguilla*) and Atlantic salmon to up to 960 mG magnetic fields from a 50-Hz AC power source. Exposed salmon exhibited no significant change in swim behaviors (Armstrong et al. 2015; Orpwood et al. 2015). In a separate study, European eel were exposed to AC magnetic fields up to 960 mG in strength, and eels were found to exhibit no changes in swim behavior, orientation ability, or passage through the tank system (Orpwood et al. 2015). As such, multiple studies of eel and salmon behavior all indicate that

magnetic fields produced by 50- to 75-Hz AC sources do not affect the behavior of magnetosensitive fish species, or that EMF from a high-frequency source is not detectable by migratory fish species known to the magnetosensitive (Richardson et al. 1976; Armstrong et al. 2015; Orpwood et al. 2015).

Additional research conducted at the U.S. Department of Energy's Oak Ridge Laboratory evaluated the ability of various freshwater fish species,¹³ including largemouth bass (*Micropterus salmoides*), the redear sunfish (*Lepomis microlophus*), and the magnetosensitive and electrosensitive pallid sturgeon (*Scaphirhynchus albus*), to detect and respond to AC magnetic fields. Observations of these species provide further support that behaviors of fish are largely unaffected by exposure to weak 50- to 60-Hz AC magnetic fields. Largemouth bass, for example, are not observed to change their behavior or swim metrics when exposed to a 24,500 mG magnetic field from a 60-Hz AC power source (Bevelhimer et al. 2015). Similarly, the swimming behavior of the magnetosensitive and electrosensitive pallid sturgeon is also unaffected by exposure to AC magnetic fields between about 18,000 to 24,500 mG in strength (Bevelhimer et al. 2015). However, changes in fish behavior were observed in response to much stronger laboratory-generated AC magnetic fields that are not found in onshore or offshore environments. For instance, the behavior of magnetosensitive and electrosensitive lake sturgeon was altered in the presence of a ~6,600 μ T (66,000 mG) 60-Hz AC magnetic field, including increased startle behaviors, fin flares, and higher rates of slowing or gliding (Cada et al. 2012), though the authors noted that “no longer-term changes in behavior or mortalities were observed” (Cada et al. 2012). Also, when exposed to extremely high (1,657,800 mG) AC magnetic fields, redear sunfish were significantly more likely to inhabit shelters nearest to the field source; however, the fish did resume a more random distribution after the field was turned off (Bevelhimer et al. 2013).

In addition to laboratory studies that investigate the specific behavioral responses of fish to AC magnetic fields, studies conducted at submarine cable sites can also be used to evaluate the behavioral responses and potential for population-level effects resulting from AC magnetic fields produced by submarine cables. Although laboratory studies allow for fine-scale assessment of behavioral changes, field studies offer a more realistic exposure environment and the opportunity to assess the responses of wild populations of marine species. Scientists at the Marine Science Institute at the University of California, Santa Barbara, together with BOEM, observed the marine communities at energized and unenergized 60-Hz submarine cable sites between 2010 and 2014 to assess whether produced magnetic fields (730 to 1,100 mG) had any effects on the distribution of marine species (Love et al., 2016). Over years of

¹³ Although these species do not occur in the Offshore Project Area, they are reviewed and relevant because magnetosensitivity developed across a diversity of fish as an evolutionary adaptation to the geomagnetic field.

surveys, researchers observed more than 40 different fish species at field sites, including demersal halibut (*Paralichthys californicus*), sanddab (*Citharichthys sordidus*), and seaperch (*Sebastes* spp); however, there were no apparent differences in fish communities resulting from an energized cable. Although the magnetic fields produced by the 60-Hz AC cable had no effect on fish distributions, researchers did observe that the physical structure of the unburied cables, regardless of whether the cable was carrying electricity or not, did attract a higher number of fish than did natural sediment bottoms (Love et al. 2016).

In conclusion, evidence from laboratory studies indicate that fish either do not readily detect 50-60 Hz AC magnetic fields, or do not alter their behavior when exposed to such fields. In addition, even when the magnetic field is increased to levels high enough to alter fish behavior (i.e., over 1,000,000 mG and orders of magnitude higher than levels produced by submarine cables), observed behavioral effects were small and reversible, suggesting that these are unlikely to result in population-level effects. Furthermore, field surveys at submarine AC cable sites demonstrated that 60-Hz magnetic fields do not significantly affect fish distributions under field conditions.

Electrosensitivity of Sturgeon Species

Of all the known electrosensitive finfish species, only one is known to occur in the Offshore Project Area—the endangered Atlantic sturgeon (*Acipenser oxyrinchus*). Atlantic sturgeon are anadromous and seasonally inhabit coastal soft sediment environments along the United States Atlantic coast. In the Mid-Atlantic Bight, sturgeon migration was found to be predictable and governed by a series of environmental cues, including temperature and light cues, and the presence of these fish are strongly correlated with sand and gravel substrates with high densities of prey (Ingram et al. 2019).

The detection thresholds and behaviors following exposure to 50-Hz AC electric fields have been tested with two sturgeon species—sterlet (*Acipenser ruthenus*) and Russian sturgeon (*Acipenser gueldenstaedtii*) (Basov 1999). Individuals exposed to 20 mV/m electric fields exhibited small changes in both orientation and search and foraging behaviors near the power source (Basov 1999). Thus, this study suggests that minor behavioral responses may occur when sturgeon are in the vicinity of electric-field intensities of 20 mV/m at 50-60 Hz.

Sensitivity of Elasmobranchs to AC EMF

Because elasmobranchs are known to be both electrosensitive and magnetosensitive, laboratory evaluations of these species' sensitivities have largely focused on low-frequency AC sources (~10 Hz), as these most closely align to the bioelectric signals naturally produced by their prey. However, information from these studies cannot be readily utilized to assess probable detection thresholds and abilities for 50-60 Hz AC fields. Moreover, Andrianov et al. (1984) observed that increasing the source frequency from 1 Hz to 10 Hz (a factor of 10) caused a 100-fold decrease in the detection ability of skates. A similar decrease in sensitivity was observed by Kempster et al. (2013) wherein shark embryos showed the strongest responses to electric fields produced at frequencies of 0.1 to 2 Hz, with decreasing sensitivity as source frequency increased up to 20 Hz, at which point embryos did not respond. Catshark (*Cephaloscyllium isabellum*) responses to 50-Hz AC sources were tested in a laboratory setting; individual sharks were exposed for 3 days to magnetic fields up to 14,300 mG (Orr 2016). During this time, researchers observed no behavioral changes in response to the magnetic field, and sharks were able to engage in normal foraging behaviors following the introduction of an olfactory stimulus. This provides evidence that 50-Hz EMF did not interfere with the normal behavioral response to this stimulus (Orr 2016). As such, these laboratory studies demonstrate that elasmobranchs are unlikely to react to EMF produced by 60-Hz AC cables.

Few field studies have been conducted to examine the potential effects of 50-60-Hz submarine AC power cables on the behavior, distributions, and populations of elasmobranchs. However, a multi-year survey conducted by Love et al. in 2016 intentionally designed part of their survey to specifically investigate possible changes to elasmobranch populations along unburied AC submarine cable sites off the coast of California. More specifically, researchers noted that the study area would be appropriate for studying effects on elasmobranchs, as the region was known to contain a high diversity of elasmobranchs. Following surveys of marine species at both energized and unenergized cable sites, researchers concluded that there was no evidence that “energized power cables in this study were either attracting or repelling these fishes [Elasmobranchs]” and thus, “energized cables are either unimportant to these organisms [Elasmobranchs] or that at least other environmental factors take precedence” (Love et al. 2016).

Sensitivity of Large Invertebrates to AC EMF

Several studies have documented the sensitivity of mobile large invertebrates to the earth's static geomagnetic field, which is used for orientation and guidance of migration (Ugolini and Pezzani 1995; Boles and Lohmann 2003; Cain et al. 2005). However, the documented detection and use of static magnetic fields by invertebrates cannot be extrapolated to 60-Hz AC magnetic fields. Few studies have been conducted to determine the behavioral responses of invertebrates to 50-60 Hz AC EMF, but the information that is available can be used to assess the likelihood that invertebrates residing in the Offshore Project Area would be able to detect EMF from the transmission cables.

Laboratory examination of the potential small-scale behavioral changes of European lobsters (*Homarus gammarus*) to AC magnetic fields was conducted by evaluating the avoidance and attraction, sheltering time, distance traveled, speed, and activity of exposed lobsters (Taormina et al. 2020). Researchers reported that AC magnetic fields of 2,000 mG had no effect on lobster activity, and concluded that such magnetic fields “do not constitute a primary factor determining European lobster’s exploratory and sheltering behavior via any attraction or repulsion” (Taormina et al. 2020). It was noted that a light gradient in the laboratory seemed to be the primary environmental cue that influenced lobster distribution, which could suggest that laboratory information may be of limited applicability to understanding the behavior of large invertebrates in the field. Thus, available field studies provide key information on the responses of these species under realistic exposure scenarios.

Studies from the Marine Science Institute at the University of California, Santa Barbara, and BOEM have been carried out in order to determine if subsea 60-Hz AC cables disrupt crustacean movements or otherwise alter distributions of marine species. This research was conducted at field sites off the coasts of California and Washington. As a part of a multi-year study, Love et al. (2017a) conducted a series of biological surveys at energized and unenergized AC submarine cable sites off California to assess both the presence and abundances of different marine species as compared to areas of natural sediment sea bottom. Invertebrates, both *Pandalus platyceros* shrimp and an octopus species (*Octopus rubescens*) were frequently observed at survey sites (Love et al. 2017a). Two years of data indicated that these species were equally likely to be found at energized and unenergized cables. However, invertebrates observed at both energized and unenergized cable sites were significantly different from those at natural sedimented areas, which led to the conclusion that physical habitat provided by the unburied cable, and not EMF, was affecting invertebrate distributions (Love et al. 2017a). As such, these surveys provide

evidence that, in the field, 60-Hz magnetic fields up to 1,100 mG do not appear to affect the distributions of large mobile marine invertebrates, like crustaceans and cephalopods.

Two studies were developed to determine the specific impacts of AC cables, if any, on harvestable crab behavior and movement (Love et al. 2015, 2017b). Love et al. (2015) observed the behaviors of two species of rock crabs (*Metacarcinus anthonyi* and *Cancer productus*) caged alongside unbundled energized and unenergized 60-Hz AC cables. Distributions of individual crabs relative to the energized and unenergized cables were recorded to determine if energized cables have an attractive or repulsive effect on the organisms. In addition, magnetic fields produced by the energized AC cable were measured and found to range between 462 and 800 mG directly adjacent to the cable and decreased to 9 mG at the distant side of the cages (Love et al. 2015). Researchers observed the distribution of crabs within cages at four separate times, and found that caged crabs were neither more or less likely to be found either adjacent to the cable or at the distant end of the cages based on the energized state of the cable. Hence, it was concluded that magnetic fields produced by the energized 60-Hz AC magnetic fields did not affect crab behaviors or distributions (Love et al. 2015).

Additional field studies were conducted by Love et al. (2017b) to evaluate whether AC cable routes present a barrier or deterrent to crab migration; crabs in Washington (*Metacarcinus magister*) and California (*Cancer productus*) were both tested. The cable off the coast of California produced a stronger magnetic field than Washington cable, up to 1,168 mG versus 428 mG, respectively (Love et al. 2017b). Crabs were held in specialized cages that bridged cable routes, and both species of crabs were observed to move freely through this available space. Hence, researchers concluded that the magnetic fields produced by the cables (up to 1,168 mG) were not barriers to crustacean movements or migrations. Therefore, the results of these field studies indicate that energized submarine 60-Hz AC cables do not affect regional populations and distributions of large crustaceans.

Evaluation of EMF Exposures from Project Cables

The magnetic fields calculated based on projected cable configurations and burial depths for the Project are shown in Table 1. At peak loading, maximum magnetic-field levels for cable buried 3.3 feet (1 m) beneath the seabed were determined to be 112 mG at the seabed, falling to 8.7 mG at 3.3 feet (1 m) above the seabed directly over the Offshore Export Cable. These values are approximately 4.5 and 57 times lower, respectively, than the 500-mG magnetic field that was demonstrated to have no behavioral effects on either Atlantic salmon or American eel. Field strengths associated with significant changes in fish behavior are multiple orders of magnitude higher (i.e., 1,657,800 mG for redear sunfish) than those expected at the Project's cables. These studies of multiple fish species indicate that the 60-Hz magnetic fields produced by the Project's cables will be below the level of detection for marine finfish species.

Similarly, during exposure to 14,300 mG 50-Hz magnetic in the laboratory, catsharks did not exhibit behavioral changes, suggesting that these fields were not detectable by elasmobranchs (Orr 2016). At peak loading for cables buried 3.3 ft (1 m) beneath the seabed, the Inter-Array Cables and Offshore Export Cables (both in the nearshore Trenchless Installation segment and along the Offshore Export Cable Route Corridor) are projected to produce magnetic fields of 68 and 112 mG, respectively, at the seabed directly above the cable. Therefore, these results suggest that the AC magnetic fields associated with the Project's cables are not detectable by resident elasmobranchs.

Based on the available information and data in Love et al. (2015, 2017a), 60-Hz AC magnetic fields of up to 1,168 mG in strength are not associated with changes in cephalopod and large crustacean behaviors and distributions. According to calculations conducted for the Project, at peak loading the maximum magnetic field is expected to be 112 mG at the seabed. This calculated value is approximately 10 times lower than those associated with no effects on caged crabs and populations of field invertebrate species. While there are no data to specifically address the AC magnetic field detection abilities of whelk (locally, 'conch') species, these mollusk species are related to bivalves and cephalopods, which were not significantly affected by field exposures to 60-Hz AC fields up to 1,168 mG. Additional information regarding the effects of chronic magnetic field exposure on sea snails, like whelk, is provided in the following section.

In summary, the available literature indicates that the EMF produced by the Project's cables would not be detectable by resident magnetosensitive fish or invertebrates. As such, operating cables are not projected to have any adverse effects the populations or distributions of fish in the Offshore Project Area.

Assessment of Induced Electric-Field Effects on Electrosensitive Finfish and Elasmobranchs

Induced electric-field levels were also calculated for this scenario, based on an Atlantic sturgeon and dogfish model, and reported in Table 6. The Atlantic sturgeon was used as a model species as a result of its documented electrosensitivity, as an ellipsoid 6 ft (1.8 m) in length and a maximum girth of 2.5 feet (0.8 m).¹⁴ The maximum modeled value, 1.4 mV/m, is projected to occur at the seabed over the Offshore Export Cable operating at peak loading. This value approximately 14 times lower than the 20 mV/m electric field reported as the threshold for behavioral changes in Russian sturgeon and sterlet (Basov et al. 1999).

Dogfish were selected due to their resident status and benthic habits and were modeled as an ellipsoid with a length of 3.3 ft (1 m) and a maximum girth of 1.25 ft (0.4 m). Based on the scientific literature, elasmobranchs can detect a 1 mV/m electric field produced by a 10-Hz power source (Andrianov et al. 1984), but their detection abilities quickly decline as the frequency of the source increases, to the point that elasmobranchs did not detect electric fields produced at frequencies above 20 Hz (Kempster et al. 2013). Because of inability of their sensory mechanisms to respond to higher frequencies, it is not expected that resident elasmobranchs would be able to detect any induced electric fields from operating Project cables.

Table 6. Calculated induced electric fields in sturgeon and dogfish models at the seabed and 3.3 ft (1 m) above the seabed for peak loading and a 3.3-ft (1 m) cable burial depth

Cable Type	Evaluation Height	Induced Electric Field (mV/m), sturgeon model	Induced Electric Field (mV/m), dogfish model
Offshore Export Cable	At the seabed	1.4	0.7
	3.3 feet (1 m) above the seabed	0.1	0.06
Inter-Array Cable	At the seabed	0.8	0.4
	3.3 feet (1 m) above the seabed	0.06	0.03

¹⁴ Girth was determined using a standard length-girth-weight relationship for the related lake sturgeon (<http://files.dnr.state.mn.us/areas/fisheries/baudette/lksweight.pdf>).

Assessment of Chronic EMF Exposure to Marine Species at Offshore Substations, WTGs, and Protected Cables

The introduction of WTGs adds vertical and hardground habitat in the coastal environment. Artificial structures, such as platforms, footings and mattresses, are readily used as habitat by reef- and hardground-associated fish and invertebrate species (Petersen and Malm 2006; Quigel and Thornton 1989). When installed in regions that are primarily soft sediment habitat, artificial structures may be an especially important habitat for such species. However, it is important to note that hardground-associated species will be attracted to these structures regardless of their ability to detect AC EMF. As such, there is the potential for long-term exposure of these species to EMF near vertical and hardground structures that is different from the transitory exposure of species simply migrating across the transmission cable route. In order to assess the potential for biological effects following chronic AC EMF exposure, the scientific literature was reviewed and compared to expected magnetic-field levels at turbine footings and Offshore Export Cables. Given the structure and expected use of scour protection around the base, both large invertebrates and fish would likely be attracted to the physical structure.

A number of commercially and recreationally important fish species are expected to occur in the Offshore Project Area, including black sea bass. Additionally, important large crustacean species, like crabs, frequently inhabit rocky crevices as shelter. Because such species will be attracted to physical structures independently of the magnetic or electric field, they are expected to reside in areas of Project EMF regardless of detection ability. Thus, hardground-associated species will likely be exposed to magnetic fields from Project cables for extended periods as they inhabit turbine footings and matted areas, which is different in duration than that expected for demersal or benthic species swimming over the buried cable.

Effects of Chronic AC EMF Exposures on Invertebrates and Finfish

Various invertebrate species have been exposed chronically to AC magnetic fields in order to determine the potential physiological and biological effects. Purple sea urchin (*Strongylocentrotus purpuratus*) embryos were incubated in a 3.4 millitesla (mT) (34,000 mG) AC magnetic field in order to assess any effects on development. While this exposure did significantly alter the timing of cell division, a 50 percent reduction in field strength resulted in cell division timing similar to that of unexposed control embryos (Levin and Ernst 1995). Neither exposure levels were associated with increased mortality.

Additional studies with purple sea urchin embryos detected minor developmental effects following exposure to 500 mG and 1,000 mG 60-Hz magnetic fields (Cameron et al. 1993; Zimmerman et al. 1990). However, an examination of the effect of AC magnetic fields on excised lobster giant axons indicated that the magnetic fields did not alter nerve function, even at magnetic-field levels as strong as 8,000,000 mG produced by a 50-Hz power source (Ueno et al. 1986).

Similarly, information from laboratory studies with fish embryos and larvae also indicates that physiological effects from chronic AC EMF exposure are unlikely. The embryonic development time of Japanese rice fish (*Oryzias latipes*) was significantly lengthened by exposure to a 1,000 mG 60 Hz magnetic field (Cameron et al. 1985). This delay was estimated to be approximately 18 hours, which was not considered likely to result in long-term or population-level effects. Additionally, other endpoints, including hatching rate, physical abnormalities, or survival, were not altered by exposure to magnetic fields (Cameron et al. 1985). The observed delay in embryonic development was approximately 18 hours, and therefore was not considered likely to cause long-term, population-level effects. Additionally, zebrafish embryos also exhibited similar delays following exposure to a 50-Hz, 10,000 mG magnetic field (Skauli et al. 2000). More recent studies indicated that zebrafish larval hatching rate, growth, and mortality were not affected by 36-day exposure to 50-Hz EMF at a level of 1 mT (10,000 mG), although yolk sac absorption rate was increased (Fey et al. 2019). Conversely, there was evidence of both cytotoxic and genotoxic responses in young rainbow trout exposed to a 50-Hz, 1 mT (10,000 mG) magnetic field for 40 days, but these did not result in decreased survival rates (Stankevičiūtė et al. 2019).

These studies indicate that there are some physiological effects in invertebrate embryos exposed to AC magnetic fields; however, exposure of embryos is not expected to be prevalent or consequential under fields conditions. First, most invertebrate embryos and larvae are passively distributed in the marine environment and are thus unlikely to reside within the Offshore Project Area long enough to be chronically exposed to EMF. Second, the natural mortality of the embryonic and larval invertebrates (and fish) is very high, with the vast majority dying before reaching reproductive maturity. Moreover, early life stages are generally considered more sensitive to environmental stressors.

Another critical endpoint of chronic exposure to AC magnetic fields are the physiological effects in older fish and invertebrates. The potential impacts of chronic AC magnetic-field exposures cannot be extrapolated from studies with early life stages, due to differences in developmental rates and physiology. Based on laboratory studies conducted with chronic AC EMF exposures, effects from chronic AC magnetic-field exposures are minor or only occur when adult fish or invertebrates are

exposed to extremely high magnetic fields. Stankevičiūtė et al. (2019) determined that Baltic clams (*Limecola balthica*) exhibited evidence of genotoxicity and cytotoxicity after a 12-day exposure to 1 mT (10,000 mG) magnetic fields from a 50-Hz source. Survival rates, however, were unaffected by exposure (Stankevičiūtė et al. 2019). Additional recent research with small sediment-dwelling worms found that exposure to AC EMF did not significantly adversely affect the behavior and physiology of these worms (Jakubowska et al. 2019; Stankevičiūtė et al. 2019). An intertidal sea snail (*Onchidium struma*) exposed to 50-Hz magnetic fields of 1000 to 5000 mG in strength for 24 to 168 hours exhibited an increased immune response, which authors theorized was likely a beneficial effect (Zhang et al. 2020). Common carp (*Cyprinus carpio*) exposed to 50-Hz magnetic fields between 1,000 mG and 70,000 mG were assessed for changes in brain histopathology (Samiee and Samiee 2017). However, only those fish exposed to magnetic-field levels greater than 30,000 mG were observed to exhibit a significant increase in brain lesions. Conversely, Cuppen et al. (2007) reported an increased immune response in goldfish exposed to 200-Hz to 5,000-Hz magnetic fields between 1.5 mG and 500 mG, which decreased mortality of disease-challenged fish. In addition, a study with rainbow trout incorporating a 60-day periodic exposure of 15-Hz magnetic fields between 1 mG and 500 mG also affected immune response; 1-hour exposures daily for 3 months resulted in increased growth and improved immune system activity in fish (Nofouzi et al. 2015). The periodic and intermittent nature of this exposure may be analogous to probable field exposures where fish may be moving in and out of a produced magnetic field. However, 1-month exposure to 50-Hz magnetic fields between 300 and 2,000 mG resulted in reduced growth and decreased digestive enzymes in exposed juvenile tilapia (*Oreochromis niloticus*) (Li et al. 2015). The authors observed no correlation between increasing effects on growth and increasing strength of the magnetic field, and moreover, the recovery of normal digestive function was re-established once the field was discontinued (Li et al. 2015).

Evaluation of Chronic EMF Exposure at Offshore Substations, WTGs, and Mattressed Areas

Where cables are installed with protective covering, the maximum magnetic-field levels calculated for peak loading at 3.3 feet (1 m) above the unburied areas along the cable route were 28 mG and 46 mG for the Inter-Array Cables and Offshore Export Cables, respectively. Given the scientific literature reviewed above, these calculated values are below the magnetic-field levels that cause physiological effects (i.e., from approximately 500 mG to greater than 10,000 mG). As such, it can be reasonably determined that hardground-associated species that would inhabit these areas along the cable route are unlikely to be injured by magnetic fields.

Based on modeling results, the volume-average magnetic field near the seabed, below where the Project's cables enter or exit the structure, is expected to be approximately 209 mG or less. These calculations represent the maximum chronic volume-average exposure of mobile hardground species identified as likely to inhabit the Offshore Project Area. Based on a review of the literature, chronic exposure to 50-60 Hz magnetic fields between approximately 500 and 10,000 mG resulted in small changes in developmental rates of embryonic fish and invertebrates (Cameron et al. 1993; Zimmerman et al. 1990; Skauli et al. 2000). However, based on field conditions, chronic exposure of fish embryos to magnetic fields from the Project's cables are not projected to occur, as most fish embryos are passively dispersed through the water column meaning exposures will be incidental and short. In comparison, adult fish seem to show less sensitivity to 50-60 Hz magnetic fields. For instance, evidence of brain lesions was observed after chronic exposure to magnetic fields approximately 140 times higher than the maximum calculated 209 mG field at the J-tube structure (Samiee and Samiee 2017).

Conclusions

Based on conservative estimates, the calculated magnetic-field levels associated with the Project's cables are determined to be well below limits established by ICES and ICNIRP to protect the health and safety of the general public. In addition, these magnetic-field levels calculated at peak loading are below levels associated with detection and behavioral changes in marine organisms and are therefore not expected to affect populations of marine organisms residing in the area.

Multiple marine species, including fish, large invertebrates, and elasmobranchs, are capable of detecting and responding to variations in the earth's static geomagnetic field (i.e., 0 Hz), and in a few cases, low-frequency electric fields (~0 to 10 Hz). Conversely, the fields associated with 50/60-Hz AC cables are not as easily perceived in the natural environment. Because of this, studies of static magnetic fields cannot be used to predict the likelihood of effects from exposure to submarine cables. As such, Exponent's evaluation relied on data from laboratory and field experiments with 50/60-Hz fields, because studies of static magnetic fields cannot be used to predict the likelihood of effects from exposure to AC submarine cables.

Exponent modeled the magnetic-field levels and induced electric field levels projected to occur at peak cable loading. Results were calculated for field strengths at the seabed, and 3.3 ft (1 m) above the seabed, in order to provide an estimate of the reduction of the magnetic and electric fields with increasing distance from the cables. Magnetic fields at the seabed will be 112 mG or lower at peak loading and will fall to 8.7 mG or less within 3.3 ft (1 m) of the seabed. These calculated field levels were then compared to the magnetic-field and induced-electric field levels reported in the scientific literature as causing behavioral responses in groups of marine species expected to inhabit the Offshore Project Area, including fish, elasmobranchs, and marine invertebrates. This assessment generated the following conclusions:

- Data from field surveys at submarine cable sites demonstrate that 60-Hz magnetic fields have no effect on the behaviors and distributions of large crustaceans: the presence of octopus at the same cable sites also suggested that cephalopods (including squid) are not affected by AC EMF.
- Calculated magnetic-field levels for the Project's cables at peak loading were determined to be below magnetic-field levels that caused behavioral changes in magnetosensitive fish species in laboratory and field studies.

- Elasmobranchs, including sharks and rays, are not expected to detect the 60-Hz AC magnetic fields produced by the Project's cables operating at peak loading.
- Calculated induced electric fields (generated with sturgeon and dogfish models) are below the published detection thresholds of resident electrosensitive species.
- For those hardground areas (Offshore Substation, WTG foundations, and mattress-covered cable areas), expected magnetic-field levels are well below levels reported to cause physiological effects following chronic exposures.

In conclusion, conservative calculations of magnetic-field and induced electric-field levels based on the Project's cable specifications and peak and average load levels indicate that the fields produced by the Project's cables will be below the detection thresholds for magnetosensitive and electrosensitive marine organisms. Because marine species' behaviors and populations are not expected to be impacted by operating the Offshore Export Cables and Inter-Array Cables, we can conclude that the EMF generated by the Project's cables will not have an adverse effect on populations of resident species.

This conclusion agrees with recent reviews of the ecological effects of Marine Renewable Energy projects. For instance, it was reported that "there has been no evidence to show that EMFs at the levels expected from MRE devices will cause an effect (whether negative or positive) on any species" (Copping et al. 2016). A recent update of this report also found that newer research has reported that biological effects are associated with exposure to magnetic- and electric-field levels much higher than those from MRE projects, although the authors cautioned that more research is needed to fully understand potential effects (Gill and Desender 2020). More specifically, a 2019 BOEM report that assessed the potential for AC EMF produced by offshore wind farm cables to affect marine populations concluded that for the southern New England area, no negative effects are expected for populations of key commercial and recreational fish species (Snyder et al. 2019). The results of this assessment are consistent with these findings.

References

- Andrianov, Y., G.R. Broun, O.B Il'inskii, and V.M Muraveiko. 1984. "Frequency characteristics of skate electroreceptive central neurons responding to electrical and magnetic stimulation." *Neurophysiology*, 16(4):364-369. Available online at: <https://doi.org/10.1007/BF01053489>. Accessed December 12, 2020.
- Armstrong, J.D., D.C. Hunter, R.J. Fryer, P. Rycroft, and J.E. Orpwood. 2015. "Behavioural responses of Atlantic Salmon to mains frequency magnetic fields." *Scottish Marine and Freshwater Science*, 6:9, 2015. Available online at: <http://dx.doi.org/10.7489/1621-1>. Accessed December 12, 2020.
- Basov, B.M. 1999. "Behavior of sterlet *Acipenser ruthenus* and Russian sturgeon *A. gueldenstaedtii* in low-frequency electric fields." *Journal of Ichthyology*, 39:782-787.
- Bedore, C.N. and S.M. Kajiura. 2013. "Bioelectric fields of marine organisms: voltage and frequency contributions to detectability by electroreceptive predators." *Physiological and Biochemical Zoology*, 86: 298-311. Available online at: <https://doi.org/10.1086/669973>. Accessed December 12, 2020.
- Bevelhimer, M.S., G.F. Cada, A.M. Fortner, P.E. Schweizer, and K. Riemer. 2013. "Behavioral responses of representative freshwater fish species to electromagnetic fields." *Transactions of the American Fisheries Society*, 142: 802-813. Available online at: <https://doi.org/10.1080/00028487.2013.778901>. Accessed December 12, 2020.
- Bevelhimer, M.S., G.F. Cada, and C. Scherelis. 2015. *Effects of Electromagnetic Fields on Behavior of Largemouth Bass and Pallid Sturgeon in an Experimental Pond Setting*. Report No. DE-AC05-00OR22725 prepared by Oak Ridge National Laboratory. Available online at: <https://tethys.pnnl.gov/sites/default/files/publications/Bevelhimer-et-al-2015.pdf>. Accessed December 12, 2020.
- BOEM (Bureau of Ocean Energy Management). 2015. *Virginia Offshore Wind Technology Advancement Project on the Atlantic Outer Continental Shelf Offshore Virginia: Revised Environmental Assessment*. OCS EIS/EA BOEM 2015-031. Available online at: <https://www.boem.gov/sites/default/files/renewable-energy-program/State-Activities/VA/VOWTAP-EA.pdf>. Accessed December 12, 2020.
- Boles, L.C. and K.J. Lohmann. 2003. "True navigation and magnetic maps in spiny lobsters." *Nature*, 421:60-63. Available online at: <https://doi.org/10.1038/nature01226>. Accessed December 12, 2020.
- Bull, A.S. and M.E. Helix. 2011. "Highlights of renewable energy studies and research in the Bureau of Ocean Energy Management, regulation and enforcement." *OCEANS'11 MTS/IEEE KONA*, Waikoloa, HI. Available online at: <https://www.infona.pl/resource/bwmeta1.element.ieee-art-000006107284>. Accessed December 12, 2020.
- Cada, G., M. Bevelhimer, A. Fortner, K. Riemer, and P. Schweizer. 2012. *Laboratory studies of the effects of static and variable magnetic fields on freshwater fish*. Report No. ORNL/TM-2012/119 prepared by Oak Ridge National Laboratory for the Water Power Program. Available online at: <https://info.ornl.gov/sites/publications/files/Pub35678.pdf>. Accessed December 12, 2020.

- Cain, S.D., L.C. Boles, J.H. Wang, and K.J. Lohmann. 2005. "Magnetic orientation and navigation in marine turtles, lobsters, and molluscs: concepts and conundrums." *Integrative and Comparative Biology*, 45:539-546. Available online at: <https://doi.org/10.1093/icb/45.3.539>. Accessed December 12, 2020.
- Cameron, I.L., K.E. Hunter, and W.D. Winters. 1985. "Retardation of embryogenesis by extremely low frequency 60 Hz electromagnetic fields." *Physiological Chemistry and Physics Medical NMR*, 17:135-138. Available online at: <https://pubmed.ncbi.nlm.nih.gov/4034677/>. Accessed December 12, 2020.
- Cameron, I., W. Hardman, W. Winters, S. Zimmerman, and A. Zimmerman. 1993. "Environmental magnetic fields: Influences on early embryogenesis." *Journal of Cellular Biochemistry*, 51(4):417-425. Available online at: <https://doi.org/10.1002/jcb.2400510406>. Accessed December 12, 2020.
- Chave, A.D., A.H. Flosadóttir, and C.S. Cox. 1990. "Some comments on seabed propagation of ULF/ELF electromagnetic fields." *Radio Science* 25(5):825-836. Available online at: <https://doi.org/10.1029/RS025i005p00825>. Accessed December 12, 2020.
- Cihlar, J. and F.T. Ulaby. 1974. *Dielectric Properties of Soils as a Function of Moisture Content*. CRES Technical Report 177-47. Available online at: <https://core.ac.uk/download/pdf/42888274.pdf>. Accessed December 12, 2020.
- Copping, A., N. Sather, L. Hanna, J. Whiting, G. Zydlewski, G. Staines, A. Gill, I. Hutchison, A. O'Hagan, T. Simas, J. Bald, C. Sparling, J. Wood, and E. Masden. 2016. *Annex IV 2016 State of the Science Report: Environmental Effects of Marine Renewable Energy Development Around the World*. Available online at: https://tethys.pnnl.gov/sites/default/files/publications/Annex-IV-2016-State-of-the-Science-Report_LR.pdf. Accessed December 12, 2020.
- Cuppen, J.J.M., G.F. Wiegertjes, H.W.J. Lobee, H.F.J. Savelkoul, M.A. Elmusharaf, A.C. Beynen, H.N.A. Grooten, and W. Smink. 2007. "Immune stimulation in fish and chicken through weak low frequency electromagnetic fields." *Environmentalist*, 27:577-583. Available online at: <https://doi.org/10.1007/s10669-007-9055-2>. Accessed December 12, 2020.
- Fey, D.P., M. Jakubowska, M. Greszkiewicz, E. Andrulewicz, Z. Otremba, and B. Urban-Malinga. 2019. "Are magnetic and electromagnetic fields of anthropogenic origin potential threats to early life stages of fish?" *Aquatic Toxicology*, 209:150-158. Available online at: <https://doi.org/10.1016/j.aquatox.2019.01.023>. Accessed December 12, 2020.
- Gill, A.B. and M. Desender. 2020. "Risk to animals from electro-magnetic fields emitted by electric cables and marine renewable energy devices." In: A.E. Copping and L.G. Hemery (eds.), *OES-Environmental 2020 State of the Science Report: Environmental Effects of Marine Renewable Energy Development around the World*. Available online at: https://tethys.pnnl.gov/sites/default/files/publications/OES-Environmental-2020-State-of-the-Science-Ch-5_final_hr.pdf. Accessed December 12, 2020.
- Hanson, M. and H. Westerberg. 1987. "Occurrence of magnetic material in teleosts." *Comparative Biochemistry and Physiology - Part A: Molecular and Integrative Physiology*, 86:169-172.

- Harrison, R.J., R.E. Dunin-Borkowski, and A. Putnis. 2002. "Direct imaging of nanoscale magnetic interactions in minerals." *Proceedings of the National Academy of Sciences*, 99:16556–16561. Available online at: <https://doi.org/10.1073/pnas.262514499>. Accessed December 12, 2020.
- Hellinger, J. and K.P. Hoffman. 2012. "Magnetic field perception in the rainbow trout, *Oncorhynchus mykiss*: magnetite mediated, light dependent or both?" *Journal of Comparative Physiology A*, 198:593-605. Available online at: <https://doi.org/10.1007/s00359-012-0732-3>. Accessed December 12, 2020.
- Hulbert, M.H., R.H. Bennett, and D.N. Lambert. 1982. "Seabed geotechnical parameters from electrical conductivity measurements." *Geo-Marine Letters*, 2:219-222. Available online at: <https://doi.org/10.1007/BF02462767>. Accessed December 12, 2020.
- Hutchison, Z., P. Sigray, H. He, A. Gill, J. King, and C. Gibson. 2018. *Electromagnetic Field (EMF) Impacts on Elasmobranch (shark, rays, and skates) and American Lobster Movement and Migration from Direct Current Cables*. OCS Study BOEM 2018-003. Available online at: <https://tethys.pnnl.gov/sites/default/files/publications/Hutchison2018.pdf>. Accessed December 12, 2020.
- ICES (International Committee on Electromagnetic Safety). 2019. *IEEE Standard for Safety Levels with Respect to Human Exposure to Electromagnetic Fields, 0 to 300 GHz*. IEEE Std C95.1-2019 (Revision of IEEE Std C95.1-2005/ Incorporates IEEE Std C95.1-2019/Cor 1-2019). Available online at: https://standards.ieee.org/standard/C95_1-2019.html. Accessed December 12, 2020.
- ICNIRP (International Commission on Non-ionizing Radiation Protection). 2010. "ICNIRP guidelines for limiting exposure to time-varying electric and magnetic fields (1 Hz to 100 kHz)." *Health Physics*, 99:818-836. Available online at: <https://doi.org/10.1097/hp.0b013e3181f06c86>. Accessed December 12, 2020.
- IEEE (Institute of Electrical and Electronics Engineers). 2010. *IEEE Recommended Practice for Measurements and Computations of Electric, Magnetic, and Electromagnetic fields with respect to Human Exposure to Such Fields, 0 Hz to 100 kHz*. IEEE Std. C95.3.1-2010. Available online at: https://standards.ieee.org/standard/C95_3_1-2010.html. Accessed December 12, 2020.
- IEEE (Institute of Electrical and Electronics Engineers). 2019. *IEEE Standard Procedures for Measurement of Power Frequency Electric and Magnetic Fields from AC Power Lines*. ANSI/IEEE Std. 644-2019. Available online at: <https://standards.ieee.org/standard/644-2019.html>. Accessed December 12, 2020.
- Ingram, C.E., R.M. Cerrato, K.J. Dunton and M.G. Frisk. 2019. "Endangered Atlantic sturgeon in the New York Wind Energy Area: implications of future development in an offshore wind energy site." *Scientific Reports*, 9:12432. Available online at: <https://doi.org/10.1038/s41598-019-48818-6>. Accessed December 12, 2020.
- Jakubowska, M., B. Urban-Malinga, Z. Otremba, and E. Andrulewicz. 2019. "Effect of low frequency electromagnetic field on the behavior and bioenergetics of the polychaete *Hediste diversicolor*." *Marine Environmental Research*, 150:104766. Available online at: <https://doi.org/10.1016/j.marenvres.2019.104766>. Accessed December 12, 2020.

- Kempster, R.M., N.S. Hart, and S.P. Collin. 2013. "Survival of the stillest: predator avoidance in shark embryos." *PLOS ONE*, 8:e52551. Available online at: <https://doi.org/10.1371/journal.pone.0052551>. Accessed December 12, 2020.
- Klimley, A.P. 1993. "Highly directional swimming by scalloped hammerhead sharks, *Sphyrna*, and subsurface irradiance, temperature, bathymetry, and geomagnetic field." *Marine Biology*, 117:1-22. Available online at: <https://doi.org/10.1007/BF00346421>. Accessed December 12, 2020.
- Levine, M. and S.G. Ernst. 1995. "Applied AC and DC magnetic fields cause alterations in the mitotic cycle of early sea urchin embryos." *Bioelectromagnetics* 16:231-240. Available online at: <https://doi.org/10.1002/bem.2250160405>. Accessed December 12, 2020.
- Li, Y., B. Ru, X. Liu, W. Miao, K. Zhang, L. Han, H. Ni, and H. Wu. 2015. "Effects of extremely low frequency alternating-current magnetic fields on the growth performance and digestive enzyme activity of tilapia *Oreochromis niloticus*." *Environmental Biology of Fishes*, 98:337-343. Available online at: <https://doi.org/10.1007/s10641-014-0263-6>. Accessed December 12, 2020.
- Lohmann, K.J., N.D. Pentcheff, G.A. Nevitt, G.D. Stetten, R.K. Zimmerfaust, H.E. Jarrard, L.C. Boles. 1995. "Magnetic orientation of spiny lobsters in the ocean: Experiments with undersea coil systems." *Journal of Experimental Biology*, 198:2041-2048. Available online at: <https://pubmed.ncbi.nlm.nih.gov/9319949/>. Accessed December 12, 2020.
- Love, M.S., M.M. Nishimoto, S. Clark, and A.S. Bull. 2015. "Identical response of caged rock crabs (Genera *Metacarcinus* and *Cancer*) to energized and unenergized undersea power cables in Southern California, USA." *Bulletin, Southern California Academy of Sciences*, 114:33-41. Available online at: <https://doi.org/10.3160/0038-3872-114.1.33>. Accessed December 12, 2020.
- Love, M.S., M.M. Nishimoto, S. Clark, and A.S. Bull. 2016. *Renewable Energy in situ: Power Cable Observation*. OCS Study BOEM 2016-008. Available online at: <https://www.boem.gov/sites/default/files/environmental-stewardship/Environmental-Studies/Pacific-Region/Studies/BOEM-2016-008.pdf>. Accessed December 12, 2020.
- Love, M.S., M.M. Nishimoto, S. Clark, M. McCrea, and A.S. Bull. 2017a. "The organisms living around energized submarine power cables, pipe, and natural sea floor in the inshore waters of Southern California." *Bulletin, Southern California Academy of Sciences*. 2017a. 116(2):61-88. Available online at: <https://doi.org/10.3160/soca-116-02-61-87.1>. Accessed December 12, 2020.
- Love, M.S., M.M. Nishimoto, S. Clark, M. McCrea, and A.S. Bull. 2017b. "Assessing potential impacts of energized submarine power cables on crab harvests." *Continental Shelf Research*, 151:23-29. Available online at: <https://doi.org/10.1016/j.csr.2017.10.002>. Accessed December 12, 2020.
- Nofouzi, K., N. Sheikhzadeh, D. Jassur, and J. Ashra-Helan. 2015. "Influence of extremely low frequency electromagnetic fields on growth performance, innate immune response, biochemical parameters and disease resistance in rainbow trout, *Oncorhynchus mykiss*." *Fish Physiology and Biochemistry*, 41:721731. Available online at: <https://doi.org/10.1007/s10695-015-0041-1>. Accessed December 12, 2020.

- Orpwood, J.E., R.J. Fryer, P. Rycroft, and J.D. Armstrong. 2015. "Effects of AC Magnetic Fields (MFs) on Swimming Activity in European Eels *Anguilla*." *Scottish Marine and Freshwater Science*, 6(8):1-20. Available online at: <https://doi.org/10.7489/1618-1>. Accessed December 12, 2020.
- Orr, M. 2016. *The potential impacts of submarine power cables on benthic elasmobranchs*. Doctoral Dissertation, The University of Auckland. Available online at: <https://researchspace.auckland.ac.nz/bitstream/handle/2292/30773/whole.pdf?sequence=2>. Accessed December 12, 2020.
- Quigel, J.C. and W.L. Thornton. 1989. "Rigs to reefs—A case history." *Bulletin of Marine Science*, 44:799-806. Available online at: <https://www.ingentaconnect.com/contentone/umrsmas/bullmar/1989/00000044/00000002/art00024#>. Accessed December 12, 2020.
- Petersen, J.K. and T. Malm. 2006. "Offshore windmill farms: Threats to or possibilities for the marine environment." *AMBIO: A Journal of the Human Environment*, 35(2):75-80. Available online at: [https://doi.org/10.1579/0044-7447\(2006\)35\[75:OWFTTO\]2.0.CO;2](https://doi.org/10.1579/0044-7447(2006)35[75:OWFTTO]2.0.CO;2). Accessed December 12, 2020.
- Pettersson, P. and N. Schönborg. 1997. "Reduction of power system magnetic fields by configuration twist." *IEEE Transactions on Power Delivery*, 12:1678-1683.
- Richardson N.E., J.D. McCleave, and E.H. Albert. 1976. "Effect of extremely low frequency electric and magnetic fields on locomotor activity rhythms of Atlantic salmon (*Salmo salar*) and American eels (*Anguilla rostrata*)." *Environmental Pollution* 10:65-76. Available online at: [https://doi.org/10.1016/0013-9327\(76\)90096-3](https://doi.org/10.1016/0013-9327(76)90096-3). Accessed December 12, 2020.
- Samiee, F. and K. Samiee. 2017. "Effect of extremely low frequency electromagnetic field on brain histopathology of Caspian Sea *Cyprinus carpio*." *Electromagnetic Biology and Medicine*, 36:31-38. Available online at: https://journals.medilam.ac.ir/files/site1/rds_journals/385/article-385-565935.pdf. Accessed December 12, 2020.
- Silva, J.M. 2006. *EMF Study: Long Island Power Authority (LIPA)*..
- Skauli, K.S., J.B. Reitan, and B.T. Walther. 2000. "Hatching in zebrafish (*Danio rerio*) embryos exposed to a 50 Hz magnetic field." *Bioelectromagnetics*, 21:407-410. Available online at: [https://doi.org/10.1002/1521-186X\(200007\)21:5%3C407::AID-BEM10%3E3.0.CO;2-V](https://doi.org/10.1002/1521-186X(200007)21:5%3C407::AID-BEM10%3E3.0.CO;2-V). Accessed December 12, 2020.
- Snyder, D.B., W.H. Bailey, K. Palmquist, B.R.T. Cotts, and K.R. Olsen. 2019. *Evaluation of Potential EMF Effects on Fish Species of Commercial or Recreational Fishing Importance in Southern New England*. OCS Study BOEM 2019-049. Available online at: https://espis.boem.gov/final%20reports/BOEM_2019-049.pdf. Accessed December 12, 2020.
- Somaraju, R. and J. Trumpf. 2006. "Frequency, temperature and salinity variation of the permittivity of seawater." *IEEE Transactions on Antennas and Propagation*, 54(11):3441-3448. Available online at: <https://doi.org/10.1109/TAP.2006.884290>. Accessed December 12, 2020.
- Stankevičiūtė, M., M. Jakubowska, J. Pažusienė, T. Makaras, Z. Otremba, B. Urban-Malinga, D.P. Fey, M. Greszkiewicz, G. Sauliūtė, J. Baršienė, and E. Andrulewicz. 2019. "Genotoxic and cytotoxic

- effects of 50 Hz 1 mT electromagnetic field on larval rainbow trout (*Oncorhynchus mykiss*), Baltic clam (*Limecola balthica*) and common ragworm (*Hediste diversicolor*)." *Aquatic Toxicology*, 208:109-117. Available online at: <https://doi.org/10.1016/j.aquatox.2018.12.023>. Accessed December 12, 2020.
- Taormina, B., C. Di Poi, A. Agnalt, A. Carlier, N. Desroy, R. Escobar-Lux, J. D'eu, F. Freytet, and C. Durif. 2020. "Impact of magnetic fields generated by AC/DC submarine power cables on the behavior of juvenile European lobster (*Homarus gammarus*)." *Aquatic Toxicology*, 220:105401. Available online at: <https://doi.org/10.1016/j.aquatox.2019.105401>. Accessed December 12, 2020.
- Tański, A., A. Korzelecka-Orkisz, L. Grubišić, V. Tičina, J. Szulc, and K. Formicki. 2011. "Directional responses of sea bass (*Dicentrarchus labrax*) and sea bream (*Sparus aurata*) fry under static magnetic field." *Electronic Journal of Polish Agricultural Universities*, 14:1-11. Available online at: <http://www.ejpau.media.pl/volume14/issue4/art-08.html>. Accessed December 12, 2020.
- Taylor, P.B. 1986. "Experimental evidence for geomagnetic orientation in juvenile salmon, *Oncorhynchus tshawytscha* Walbaum." *Journal of Fish Biology*, 28:607-62. Available online at: <https://doi.org/10.1111/j.1095-8649.1986.tb05196.x>. Accessed December 12, 2020.
- Ueno, S., P. Lövsund, and P. Öberg. 1986. "Effect of time-varying magnetic fields on the action potential in lobster giant axon." *Medical and Biological Engineering and Computing*, 24:21-526. Available online at: <https://doi.org/10.1007/BF02443969>. Accessed December 12, 2020.
- Ugolini, A. and A. Pezzani. 1995. "Magnetic compass and learning of the y-axis (sea-land) direction in the marine isopod *Idotea baltica basteri*." *Animal Behaviour*, 50:295-300. Available online at: <https://doi.org/10.1006/anbe.1995.0245>. Accessed December 12, 2020.
- Walker, M.M., T.P. Quinn, J.L. Kirschvink, and C. Groot. 1988. "Production of single-domain magnetite throughout life by sockeye salmon, *Oncorhynchus nerka*." *Journal of Experimental Biology*, 140:51-63. Available online at: <https://jeb.biologists.org/content/jexbio/140/1/51.full.pdf>. Accessed December 12, 2020.
- Wilson, J.G. 1986. *Electrical Properties of Concrete*. Doctoral Dissertation, The University of Edinburgh.
- Zhang, M., J. Wang, Q. Sun, H. Zhang, P. Chen, Q. Li, Y. Wang, and G. Qiao. 2020. "Immune response of mollusk *Onchidium struma* to extremely low-frequency electromagnetic fields (ELF-EMF, 50 Hz) exposure based on immune-related enzyme activity and De novo transcriptome analysis." *Fish and Shellfish Immunology*, 98:574-584. Available online at: <https://doi.org/10.1016/j.fsi.2020.01.062>. Accessed December 12, 2020.
- Zimmerman, S., A.M. Zimmerman, W.D. Winters, and I.L. Cameron. 1990. "Influence of 60-Hz magnetic fields on sea urchin development." *Bioelectromagnetics*, 11:37-45. Available online at: <https://doi.org/10.1002/bem.2250110106>. Accessed December 12, 2020.

Attachment A

Cable Configurations and Burial Depths

Cable Configurations

Magnetic-field and induced electric-field levels for the Project were calculated for five configurations as summarized in Table A-1. An individual Inter-Array Cable and Offshore Export Cable were each modeled at two burial depths, while the Offshore Export Cables in the Trenchless Installation conduits nearshore were modeled as a set of three parallel cables at one burial depth. Both cable types are 3-core cables, all with 3-phase conductors contained within a single large cable. While the Inter-Array Cable and Offshore Export Cables in the Trenchless Installation conduits contain copper conductors, the Offshore Export Cables along the majority of the Offshore Export Cable Route Corridor will contain aluminum conductors. A cross-sectional drawing indicating the various components and dimensions of such cables is shown in Figure A-1.

For most of the route, the cables will be separated at a distance of 165 ft (50 m) and buried to a target depth of 3.3 to 16 ft (1 to 5 m) beneath the seabed (see Figure A-1); however, for the calculations, a conservative burial depth of 3.3 ft (1 m) was assumed, measured from the seabed to the top of the cable's outer diameter (OD). Where it is impracticable to bury the cables, they may lie on the surface of the seabed for short areas, will be enclosed in a CPS, and covered with protective concrete mattresses or rock berms. The minimum total protective coverings for these short surface-laid installations will be at least 1-ft (0.325-m) thick. The potential ability of these mattresses or other covering to attenuate magnetic-field levels was not considered; their primary effect to calculations was to effectively change the cable burial depth to 1 ft (0.325 m).

In the nearshore segment between the Cable Landing Location and the Offshore Trenchless Installation Punch-Out, Offshore Export Cables will be installed via Trenchless Installation. The minimum center-to-center separation between the nine Offshore Export cables' Trenchless Installation pipes in this nearshore segment will be approximately 26 ft (8 m). The burial depth over most of this portion of the route is expected to be significantly greater than in other portions of the route, with most of the Trenchless Installation pipes buried at a depth of 82 to 98 ft (25 to 30 m). At this burial depth, calculated field levels will be much less than 0.1 mG, and likely near background levels. Nonetheless, the burial depth of the Offshore Export Cables in Trenchless Installation conduits was conservatively modeled at the same minimum depth of 3.3 feet (1 m) as the individual Offshore Export Cable and Inter-Array Cable to overestimate field levels.

Evaluations of field levels at these minimum heights are designed to describe the likeliest exposure zone for demersal fish. A detailed table summarizing the modeling inputs for each of these cable configurations is shown in Table A-1.

The peak loading for a 230-kV Offshore Export Cable is determined by the highest per-phase conductor current being transmitted from the wind farm operating at its maximum total generating capacity of between 2,500 and 3,000 MW with a power factor of 0.95 at the POI. The current in each cable is calculated by taking into consideration that there will be three Offshore Substations, each of which will connect to three Offshore Export Cables. Similarly, the peak loading for a 66-kV Inter-Array Cable is determined by the highest per-phase conductor current being transmitted from a line of five WTGs, connected in series, each operating at its maximum total generating capacity of 14.7 MW with the maximum power factor the WTGs are able to provide. The average loading for these respective cables is determined by applying the same total power generation capacities, while utilizing the wind farm's capacity factor of 45 percent, as indicated by Ramboll engineers, at normal operating voltage, along with an added 10% safety buffer.

Table A-1. Summary of offshore modeling configurations

Configuration	1a	1b	2a	2b	3a
Description	Inter-Array Cable*		Offshore Export Cable		Offshore Export Cable in the nearshore Trenchless Installation†
Voltage	66 kV		230 kV		
Average Loading (per conductor)	353 A {374 A}		587 A		
Peak Loading (per conductor)	715 A {855 A}		950 A		
Conductor Cross Section	630 mm ² {1000 mm ² }		1200 mm ²		
Cable Type, Nominal OD	3-core-XLPE, 6.6-inch (in) OD (168 millimeter [mm]) {7-inch (in) OD (178 millimeter [mm])}		Al 3-core XLPE, 10.2-in OD (260 mm)		Cu 3-core XLPE, 10.2-in OD (260 mm)
Distance Between Conductor Centers within Cable	2.6 in [65.9 mm] {2.5 in [63.9 mm]}		4.2-in (105.8 mm)		
Cable Pitch (m)	3‡				
Minimum Horizontal Distance between Cables	> 66 ft (> 20 m)		165 ft (50 m)		26 ft (8 m)
Installation Type	Buried	Surface-Laid§	Buried	Surface-Laid§	Buried
Minimum Target Burial Depth to Top of Cable	3.3 ft (1 m)	1 ft (0.325 m)	3.3 ft (1 m)	1 ft (0.325 m)	3.3 ft (1 m)
Evaluation Heights	At the seabed and 3.3 ft (1 m) above the seabed**				

* The design of the Inter-Array Cable has changed. The new design will reduce field levels compared to those originally calculated. Therefore all modeling is conservatively based on the original design, but the new design parameters are included. The format in this table is “New Design {Modeled Design}”

† The Offshore Export Cable in the nearshore Trenchless Installation configuration consists of three Offshore Export Cables parallel to one another, separated by a center-to-center distance of 26 feet (8 m).

‡ Inter-Array Cables and Offshore Export Cables are conservatively modeled for a cable pitch of 10 ft (3 m). Magnetic- and induced electric-field levels would also be expected to be lower for lower cable pitch (e.g., 8 ft [2.5 m]).

§ Surface-laid cables will be enclosed in a CPS with a 12-in-thick (300-mm) collar and covered with a post-lay rock cover or concrete mattress that is 1-in to 5-in (25-mm to 125-mm) thick, resulting in a total minimum effective burial depth of at least 13 in (325 mm).

**Where covered by a rock berm or concrete mattress, the evaluation heights are at the top of the protective cover and at a height of 3.3 ft (1 m) above the protective cover.

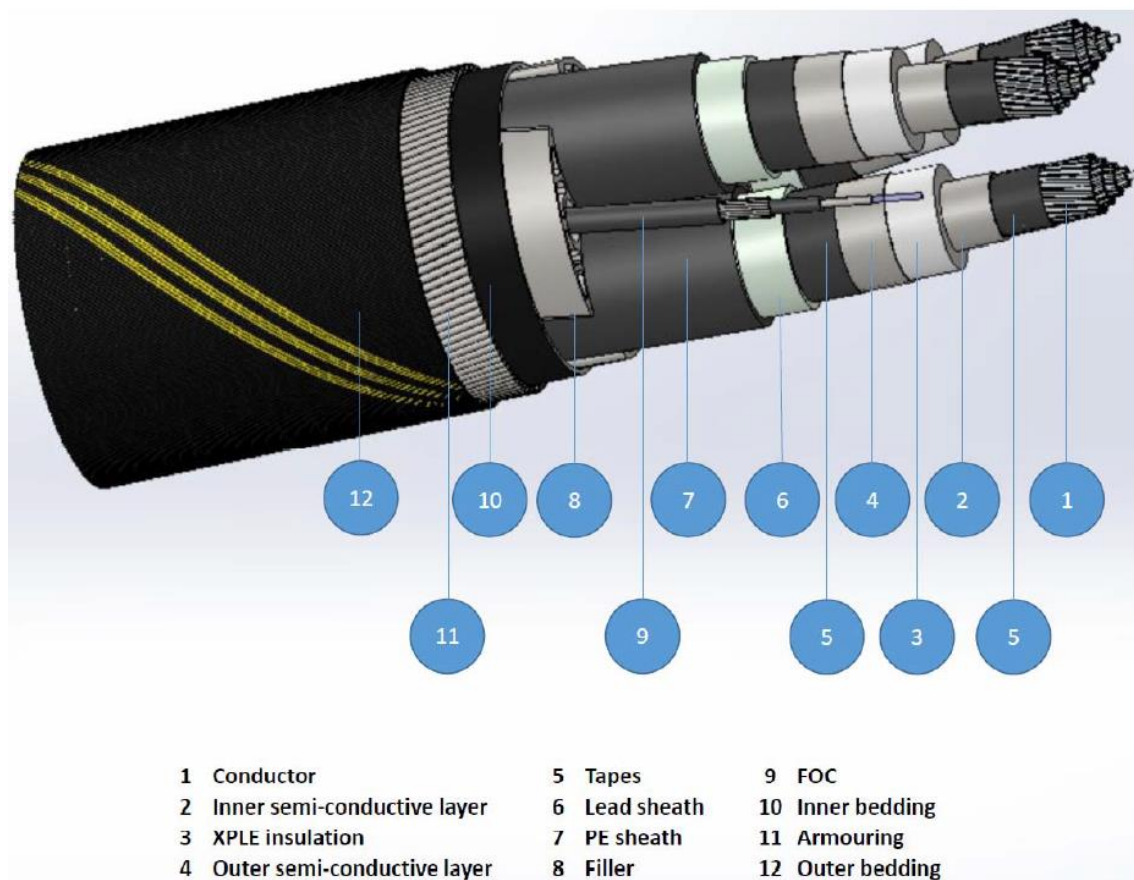

Figure A-1. Illustrative cross-section of an example 3-core submarine cable with helically-twisting conductors. Numbers identify the various layers of a submarine cable.

WTG and Offshore Substation Structures

The Offshore Substations and WTGs are relatively large structures and will introduce new habitats for marine life regardless of the presence, or relative strength, of magnetic and induced electric fields. Additionally, the proximity of multiple Project cables as they converge at these structures may contribute to additive effects from overlapping fields. Thus, we have created models for the geometry of these structures, including a most conservative arrangement of Project cables, and calculated volume-averaged field values in regions around a WTG and an Offshore Substation where marine organisms may congregate.

WTG Foundation

The design of the WTG and Inter-Array Cables have been updated subsequent to the original designs assessed by Exponent. These design changes are described further below in this section. However, the new design will reduce field levels compared to those originally calculated. Therefore, modeling of the WTG is conservatively based on the original design, with dimensions described as follows.

The foundations of the WTGs, as modeled, consist of a monopile structure with a minimum OD of 28 ft (8.5 m) at the seabed, which runs vertically through the water column. The Inter-Array Cables traverse down through the interior of the monopile with 5.2 ft (1.6 m) between the perimeter of the monopile's OD at the seabed and the center of each Inter-Array Cable. A maximum of three Inter-Array Cables will be spaced around the circumference of the monopile with an approach angle of not less than 90 degrees between two adjacent cables. Exponent modeled the WTG configuration with three Inter-Array Cables spanning 180 degrees, as shown below in Figure A-2.

A 3.3-ft (1-m) thick layer of scour protection will lie upon the seabed extending 43 ft (13 m) from the OD of the monopile foundation. Thus, the scour protection extends away from the monopile foundation, and is modeled with an OD of 112 ft (34 m).

The Inter-Array Cables exit the monopile at a height of 6.6 ft (2 m) above the scour protection, at an angle of approximately 45 degrees from the vertical, separating from one another radially as illustrated in Figure A-2. The Inter-Array Cables leave the monopile inside a CPS with an OD estimated as 14-inches (in; 356-millimeters [mm]), and they travel from the edge of the monopile down until they reach the top layer of scour protection material located around the base of the monopile, upon which the cables lie as they travel radially away from the monopile.

As noted above, Exponent understands that the design of the WTG has been updated. Updates to the Project design for the WTG now a monopile structure with a minimum OD of 23 ft (7 m), and that a maximum of two Inter-Array Cables will connect to any individual WTG. These cables will still exit the central pillar at an angle of 45 degrees from vertical, but at a height of 9.8 ft (3 m) above the scour protection at the base of the monopile. The scour protection will have an OD of 98 ft (30 m). The new Project design also indicates that the conductor size and outer diameter of the Inter-Array Cables will be decreased, as will both the peak and average loading values. These design revisions are expected to generate lower volume-average field levels compared to what was reported in Exponent's previous assessment, which therefore remains a more conservative estimate of field values.

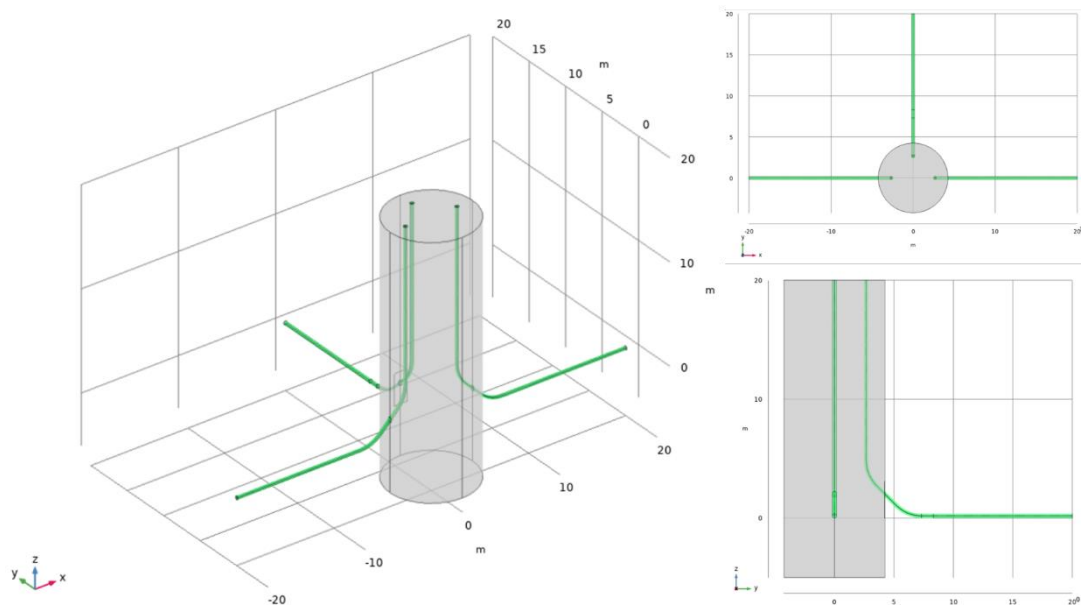

Figure A-2. Monopile foundation modeling configuration of the WTG. Green cables represent Inter-Array Cables. Top right: top view. Bottom right: side view.

Offshore Substation Foundation

The foundation of the Offshore Substation consists of a jacket structure, with the Inter-Array Cables and Offshore Export Cables traveling along the perimeter of the jacket inside steel J-tubes. The cables are conservatively assumed to be arranged around the sides of a rectangular platform. The rectangle at the top level of the jacket structure measures approximately 66 ft by 89 ft (20 m by 27 m) and the center-to-center spacing between adjacent J-tubes is modeled with a minimum spacing of 7.2 ft (2.2 m). The jacket structure near the seabed measures 92 ft by 118 ft (28 m by 36 m). The cables travel parallel to each other at minimum separation to the point where they exit the J-tubes, after which they separate from each other and from the jacket face, as illustrated in Figure A-3.

The design of the Offshore Substations includes six J-tubes on the north face of the jacket structure, all sized for Inter-Array Cables; six J-tubes on the east face of the jacket structure, all also sized for Inter-Array Cables; and five J-tubes on the south face of the jacket structure, one sized for an Inter-Array Cable and four sized for Offshore Export Cables. Each J-tube is occupied by at most a single Project cable. Not all J-tubes will necessarily be in use simultaneously. For example, an Offshore Substation may require only 3 Offshore Export Cables and 11 Inter-Array Cables. Nonetheless, the model was developed assuming all J-tubes contain energized cables. This not only permits for an assessment of a conservative scenario in terms a maximum calculated magnetic and electric fields, but it also

accommodates for a rearrangement of which J-tubes are occupied by energized Project Cables without affecting the field assessment values.

Thus, the model of the Offshore Substation included a maximum of six J-tubes installed on one face of the jacket structure. The most conservative arrangement of cables includes four Offshore Export Cables and one Inter-Array Cable on the south jacket face and six Inter-Array Cables on the east face. The north jacket face also includes six J-tubes for Inter-Array Cables. However, since the J-tubes are distributed along a larger perimeter than in the case of the east face, the volume-averaged EMF values at this face will be lower than in the case of the east face. Accordingly, only the south and east faces of the OSS jacket were modeled in this report, as illustrated in Figure A-3 below.

At the bottom jacket, the J-tubes curve to a 45-degree angle from the vertical, and the Inter-Array Cables or Offshore Export Cables exit the J-tubes at approximately 6.6 ft (2.5 m) above the seabed. No scour protection layer is included in the model of the Offshore Substations. The Inter-Array Cables and Offshore Export Cables exit the J-tubes inside a CPS with an OD estimated as 13-in (336 mm) for the Inter-Array Cables and 20.5 in (520 mm) for the Offshore Export Cables. Upon exiting the J-tubes in the CPS, the cables extend toward, and into, the seabed and are assumed to be buried within a minimum distance permitted by the allowed bend radius until the 3.3 ft (1 m) target burial depth is reached.

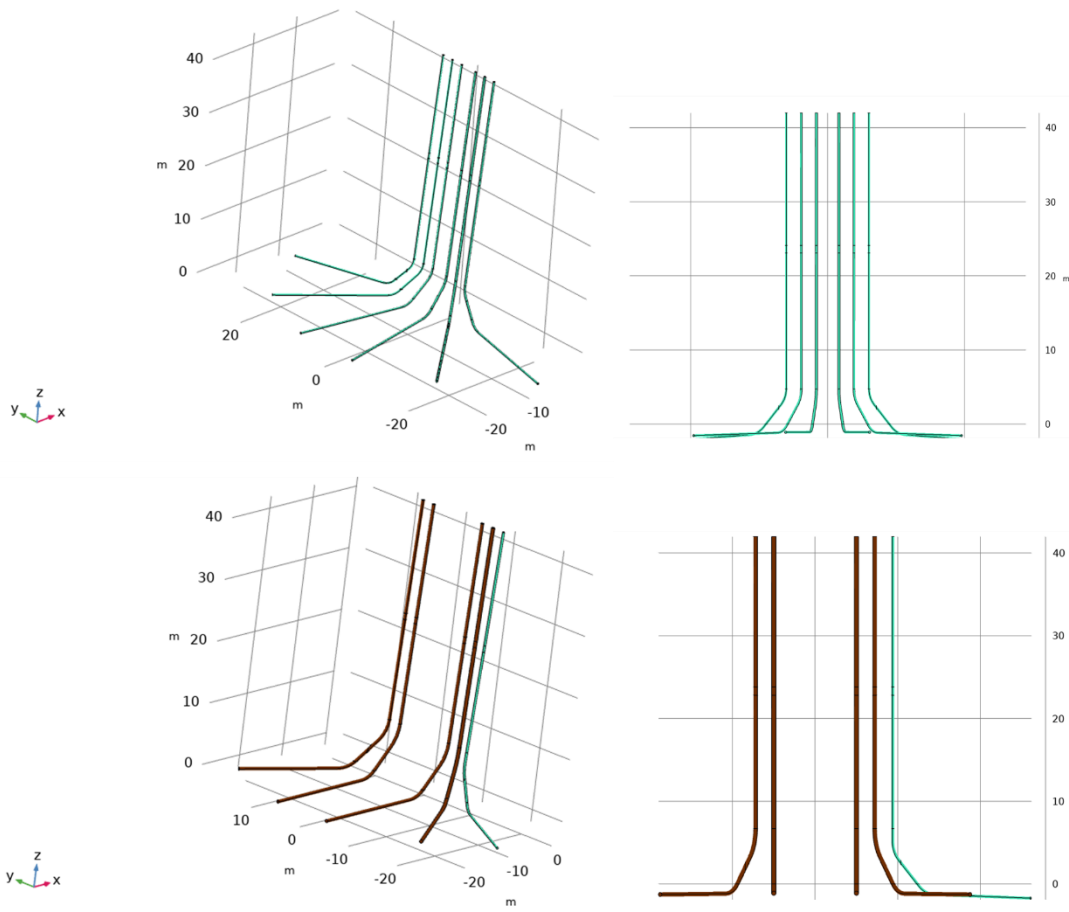

Figure A-3. Jacket foundation modeling configuration for cables on the Offshore Substations. Top images show the east face geometry while the bottom images show the south face geometry. Green lines represent Inter-Array Cables and brown lines represent Offshore Export Cables.

Attachment B

Calculation Methods and Assumptions

Tetra Tech and Ramboll provided data to Exponent on the preliminary cable design, as well as the loading for each proposed cable configuration. These input data were discussed in Attachment A, Table A-1, and related text. From these data, Exponent developed models of the five offshore configurations of the cables for computation of the magnetic and induced electric fields.

Magnetic Fields and Induced Electric Fields in Seawater

Magnetic-field calculations were performed using data including current, burial depth, and conductor configurations. As noted in the body of this report, the electric field associated with voltage applied to the conductors within the cables is entirely shielded by grounded metallic sheaths and steel armoring around each cable. Magnetic fields, however, will induce a small electric field in the seawater, which may be detectable by certain electrosensitive marine organisms.

All calculations were performed using 3D FEA in COMSOL Multiphysics (version 5.5). The simulation used the magnetic-field physics interface of COMSOL to solve the time-harmonic Maxwell-Ampere's Law for the magnetic fields generated by the Inter-Array Cables, Offshore Export Cables, and Offshore Export Cables in Trenchless Installation conduits. The FEA model was validated against a published reference (Pettersson and Schönborg 1997) for the case of a straight section of helically-twisted, 3-phase conductors. Pettersson and Schönborg (1997) also included a comparison to empirical measurements.

The inputs to the simulations were the conductor geometry (i.e., cable diameter, conductor spacing, and pitch of the helical twisting), burial depth of the cable, material properties of the seabed, the protective mattress covering, and seawater.¹⁵ The magnetic-field levels offshore were calculated at the seabed surface, as well as at a height of 3.3 ft (1 m) above the seabed, in accordance with IEEE Standard 0644-2019 and IEEE Standard C95.3.1-2010 (IEEE 2010, 2019). Results are reported in units of mG as the maximum root-mean-square flux density value. The material properties used in simulations include conductivity, relative permittivity, and relative permeability, as noted in Table B-1.

The Offshore Export Cables are proposed to be separated by distances of >165 ft (50 m) as they travel from the Offshore Substation to the Offshore Trenchless Installation Punch-Out, so were modeled in isolation from one another. Similarly, the Inter-Array Cables are proposed to be separated by a large distance in regions away from WTGs and Offshore Substations, so were also modeled in isolation from one another. Where the Offshore Export Cables approach landfall nearshore in Trenchless Installation

¹⁵ Calculated magnetic-field levels in other common sediment types or in freshwater would not be substantially different from those calculated here.

conduits, they may be separated by a center-to-center distance as short as 26 ft (8 m). To ensure that the calculations captured any additive effects of overlapping magnetic fields from adjacent single cables the nearshore Trenchless Installation configuration was modeled as three parallel Offshore Export Cables with a 26 ft (8 m) center-to-center spacing. More detailed calculation results for magnetic fields and induced electric fields within marine organisms are provided in below and in Attachment C.

Calculations were performed at the seabed surface and at a height of 3.3 feet (1 m) above the seabed in accordance with IEEE Std. 0644-2019 and IEEE Std. C95.3.1-2010 (IEEE 2010, 2019). Certain simplifying assumptions were made to perform calculations: 1) there was no attenuation of magnetic fields from any surrounding material such as the seabed, the earth, grout, mattresses, rock berms, or other materials; 2) the reduction in the magnetic field outside the cable by the cable armoring (ferromagnetic shielding and induced eddy currents) was not included; and 3) there were no unbalanced currents flowing along the outer sheaths of the cables. These modeling assumptions were made to ensure that the calculated field levels would overestimate the actual field level at any specified loading and burial depth.

Table B-1. Material properties used for calculating 60-Hz field levels in seawater

Material	Conductivity (Siemens per meter)	Relative Permittivity	Relative Permeability	Reference
Seawater	5	72	1	Chave et al. 1990; Somaraju and Trumpf 2006
Seabed	1.1	30	1	Chave et al. 1990; Hulbert et al. 1992; Cihlar and Ulaby 1974
Concrete	0.04	200	1	Wilson 1986

Electric Fields Induced in Marine Organisms

As noted in the body of this report, the magnetic fields from the Project's cables will induce weak electric fields in the seawater above the cables; this induced electric field may be detectable by certain electrosensitive marine species. Two representative species—the Atlantic sturgeon and the dogfish—were modeled as homogeneous ellipsoids to calculate the magnitude of the induced electric field that may be sensed by some marine organisms swimming above the cables. Although larger animals will induce larger electric fields, the likelihood that an electrosensitive species will detect and respond to the 60-Hz induced electric field will be determined by the species' specific detection threshold.

Assessment Approach

Exponent used two separate assessment approaches for evaluating the different Project elements with respect to EMF.

Buried Cables: Generally, the Inter-Array Cables and the Offshore Export Cables will be buried. After construction, the interaction of interest will be detection of EMF by marine species in the offshore environment; there is concern that detection of EMF might affect migration, location preferences, or social behavior. If EMF can be detected by some species, the follow-on question is whether this EMF detection can affect or alter the behavior of these species resulting in potential deleterious population-level effects.

For this reason, the magnetic-field and induced electric-field levels associated with the submarine cables were assessed by calculating them along a transect perpendicular to the cables at a height of 3.3 ft (1 m) above the seabed as relevant reference locations for species on the seabed and most mobile marine species above.¹⁶ The calculated field levels were then compared to the detection thresholds of various marine species expected to be in the Offshore Project Area (e.g., sharks, fish including key groundfish species, and larger crustaceans such as crabs and lobsters) to assess the likelihood of detection that could lead to alterations of animal behavior.

Protective Mattresses: In contrast to the buried cables, the small portion of the cables to be covered with protective mattresses are expected to generate a reef effect, which has been observed at other established wind farm sites (Petersen and Malm 2006).

Since the physical structure of the protective mattresses covering small portions of the cables is likely to attract certain species to these new habitat features, regardless of the presence of EMF, the question of detection important for the assessment of the buried cables is not as important for the surface-laid cables with protective covering. Rather, since the new habitat will encourage certain marine species to spend a greater fraction of time relatively close to the sources of EMF, the question of assessment becomes whether long-term exposure to EMF, which is more likely to occur near these structures, is likely to have biological effects on those species.

¹⁶ This height is consistent with worldwide assessments (e.g., ICES 2019, and ICNIRP,2010) and is meant to capture species swimming in close proximity to the seabed.

To answer this question, magnetic-field and induced electric-field levels at surface-laid portions with protective covering were assessed by calculating field levels along a transect perpendicular to the cables at the seabed (or top of the protective covering) as a conservative reference location. These field levels were compared to those reported in the scientific literature where physiologic responses were measured over longer periods than are typically used for acute behavioral studies.

WTGs and Offshore Substations

All calculations for the WTGs and Offshore Substations were performed using FEA in COMSOL Multiphysics (software version 5.5), with the same methods applied to the modeling of the Inter-Array Cables, the Offshore Export Cables, and the Offshore Export Cables in Trenchless Installation conduits. In contrast to the relatively simple modeling geometry, however, the models of the WTGs and particularly the Offshore Substation are substantially more complex. As shown in Figure 3 in the body of the report, the separation of the cables away from the Offshore Substation's monopile and their divergence requires a significantly larger modeling domain. The calculation physics and approach used in COMSOL, however, is the same as for the Inter-Array Cables and Offshore Export Cables and solves the time-harmonic Maxwell-Ampere's Law for the magnetic fields generated by modeled cables. The same conservative assumptions (neglecting shielding effects) used for the modeling of individual cables were also used for the individual cables in the WTG and Offshore Substation models.

Other Modeling Considerations

Cable Shielding Effects

As discussed above, the modeling approach is designed to produce conservative results for the maximum magnetic-field and induced electric-field levels. The models do not account for the attenuation of magnetic fields from conductor sheaths and outer steel armoring of the cables, nor do they include the significant shielding likely to occur due to the steel J-tubes at the Offshore Substation foundations.

A previous study shows that flux shunting accounted for an almost 2-fold reduction in the magnetic field, with a much smaller reduction attributable to eddy currents (Silva et al. 2006). In addition, a recent study submitted to BOEM performed post-construction measurements over similar AC 3-core, cross-linked polyethylene submarine cables. One finding from that report was that “[t]he magnetic field produced by the [AC cable] was ~10 times lower than modeled values commissioned by the grid operator...”

(Hutchison et al. 2018).¹⁷ The modeling method applied here is more sophisticated than the method used in previous modeling of offshore submarine cables (Hutchison et al. 2018) because it accounts for the helical twisting of the conductors, which results in lower calculated magnetic-field levels.

Unbalanced Currents and Ground Currents

Another factor not accounted for in these models is the magnetic field resulting from unbalanced currents flowing along the sheaths or armoring of the cables. These currents can occur due to unequal current flows among the three phases of an AC transmission line or can occur when the ground at one end of the cable is at a different electric potential than the other end of the cable. In this case, ground currents can flow along the armoring or sheaths. While the degree of imbalance of the currents flowing on each of the phase conductors can be controlled to some extent by system design and operation, ground currents may be completely unrelated to the generation or transmission of electricity by the Project and therefore are more difficult to control or predict. The combination of unbalanced phase currents and grounding-related currents can be thought of as a single-phase effective net current flowing straight along the cable. Hutchison et al. (2018) reported measurement data for an AC submarine cable that indicate the highest measured AC field (near to the cable itself) is produced by the phase currents, but at some distance away, unbalanced AC currents on the cable can have a much weaker but noticeable contribution to the AC magnetic field.

¹⁷ Note that while the Hutchison et al. (2018) report focused on submarine direct current transmission lines, a portion of the report also reported measurements around an AC transmission cable, which is referenced here.

Attachment C

Calculated Magnetic- and Electric-Field Levels for Modeled Cable Configurations

Project Cables

Magnetic-field and induced electric-field levels were assessed for five offshore cable configurations, the parameters of which are summarized in Attachment A, Table A-1. These five configurations vary in cable type (indicative of cable dimensions and associated loading parameters), cable number, and effective burial depth. A summary of the primary results is provided in the EMF Calculation Results section of this report, while more detailed calculated field levels for all configurations are provided below.

To illustrate the distribution of the magnetic fields associated with the transmission cables, the calculated magnetic-field levels above the 66-kV Inter-Array Cables, the 230-kV Offshore Export Cables, and the three adjacent 230-kV Offshore Export Cables in Trenchless Installation conduits for a 3.3-ft (1-m) burial depth and peak loading are plotted in Figure C-1, Figure C-2, and Figure C-3, respectively. The calculated magnetic field at a height of 3.3 ft (1 m) above the seabed is highest directly above the buried cables (Inter-Array Cables, 5.2 mG; Offshore Export cables, 8.7 mG; Offshore Export Cables in conduits, 8.7 mG) and decreases rapidly with distance. All calculated field levels are well below the ICNIRP reference level of 2,000 mG and the ICES exposure reference level of 9,040 mG for exposure of the general public.

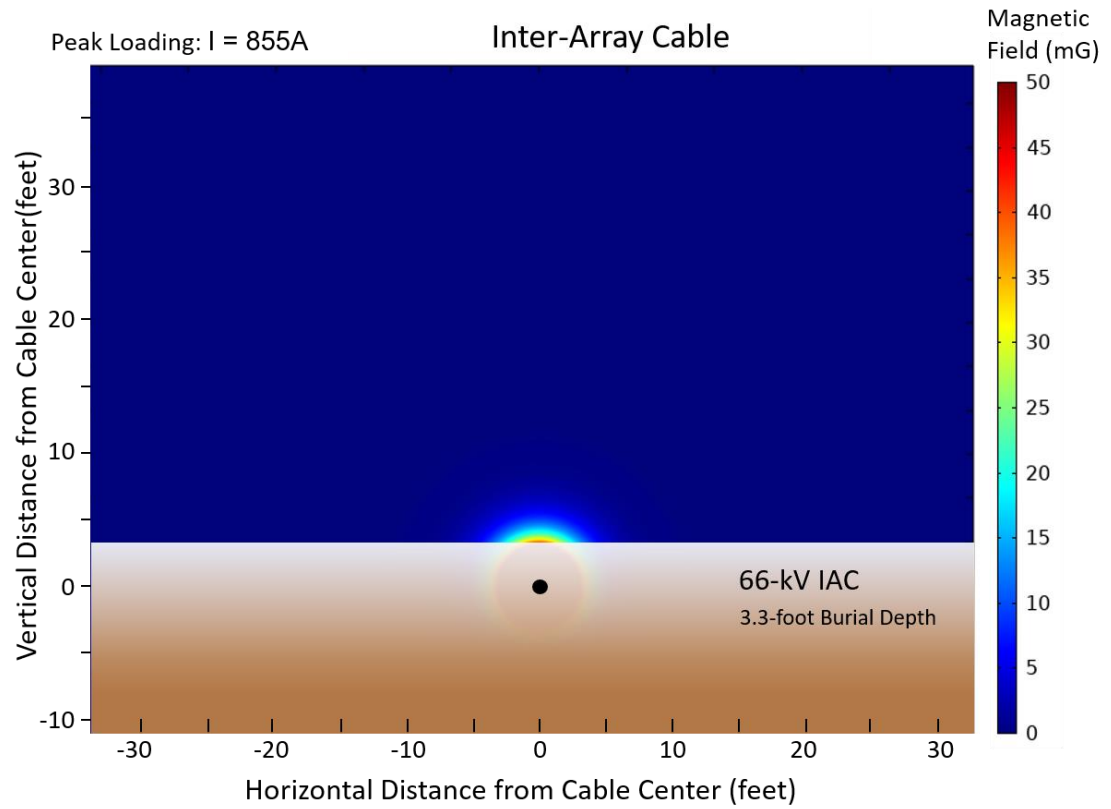

Figure C-1. Calculated magnetic-field levels in seawater above the 66-kV Inter-Array Cable for a 3.3-ft (1-m) burial depth and peak loading.

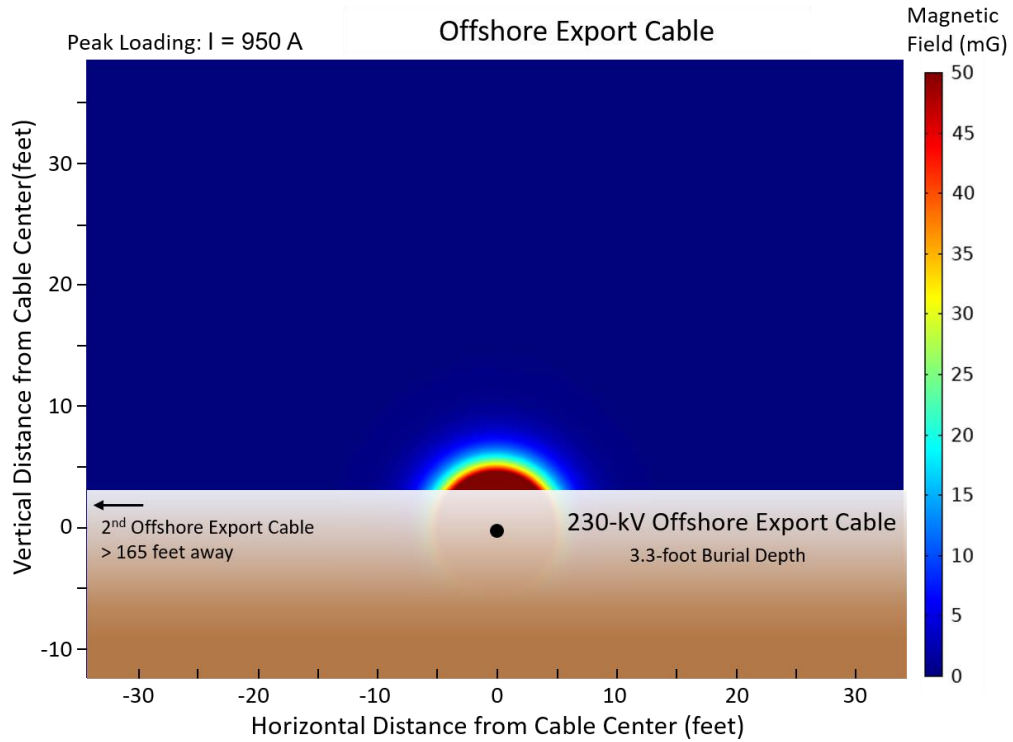

Figure C-2. Calculated magnetic-field levels in seawater above the 230-kV Offshore Export Cable for a 3.3-ft (1-m) burial depth and peak loading. As indicated in the figure, the nearest Offshore Export Cable is more than 66 ft (20 m) away and is not expected to change the magnetic-field levels from those shown here.

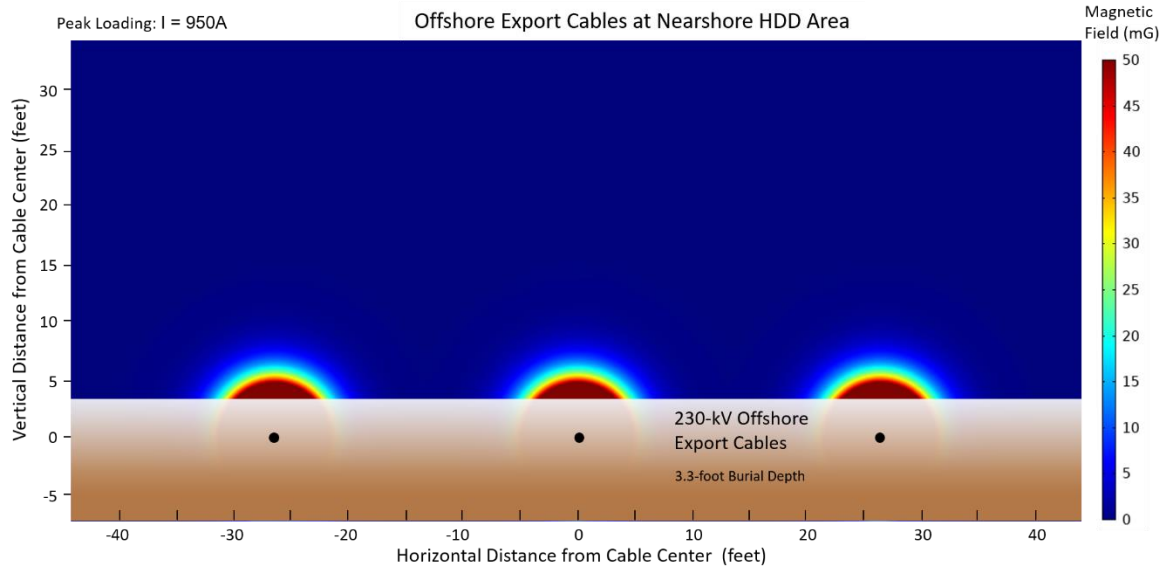

Figure C-3. Calculated magnetic-field levels in seawater at the shore landing above three parallel 230-kV Offshore Export Cables in the nearshore Trenchless Installation conduits for a 3.3-ft (1-m) burial depth and peak loading. The center-to-center spacing between Offshore Export Cables is 28 ft (8.5 m).

Cable Modeling Results

Calculated magnetic- and electric-field levels in seawater are provided below for each of the five cable configurations summarized in Attachment A, Table A-1. Figures are shown for a 66-kV Inter-Array Cables, a 230-kV Offshore Export Cable, and a set of three adjacent 230-kV Offshore Export Cables in Trenchless Installation conduits at a 3.3-ft (1 m) burial depth and both average and peak loading. Summary tables are also shown for all modeled configurations for both average and peak loading, as follows:

- Calculated magnetic-field levels in seawater are summarized in Table C-1 and Table C-2 for all modeled cable configurations for transects at the seabed and at a height of 3.3 ft (1 m) above the seabed, and for average and peak loading.
- Calculated electric-field levels induced in seawater are summarized in Table C-3 and Table C-4 for all modeled cable configurations for transects at the seabed and at a height of 3.3 ft (1 m) above the seabed for both average and peak loading.
- The calculated electric-field levels induced in representative marine species are summarized in Table C-4 and Table C-5.

Calculated field levels at average loading are plotted as a function of horizontal distance from the cables in Figure C-4 through Figure C-6 (magnetic-field levels) and Figure C-7 through Figure C-9 (induced electric-field levels) for each of the representative cable configurations. Similarly, calculated field levels at peak loading are plotted in Figure C-10 through Figure C-15. All figures present results for calculations of cables installed at a 3.3-ft (1-m) burial depth. Results for this installation type are expected to be representative of those encountered along most of the proposed cable route under typical loading.

Table C-1. Calculated AC magnetic-field levels (mG) at specified horizontal distances from AC cables for average loading

Cable	Voltage	Installation Type	Location	AC Magnetic Field (mG)		
				Max (0 ft)	±5 ft (±1.5 m)*	±10 ft (±3 m)*
Inter-Array Cable	66-kV	Buried (3.3 ft [1 m])	Seabed	30	3.8	0.2
			3.3 ft (1 m) above the seabed	2.3	0.7	<0.1
		Mattress-Covered (1 ft [0.3 m])	Top of the protective cover	331	8.0	0.2
			3.3 ft (1 m) above the protective cover	12	2.3	0.1
Offshore Export Cable	230-kV	Buried (3.3 ft [1 m])	Seabed	69	9.4	0.4
			3.3 ft (1 m) above the seabed	5.4	1.7	0.1
		Mattress-Covered (1 ft [0.3 m])	Top of the protective cover	708	20	0.6
			3.3 ft (1 m) above the protective cover	29	5.7	0.3
Offshore Export Cable: Trenchless Installation	230-kV	Buried (3.3 ft [1 m])	Seabed	69	9.7	0.4
			3.3 ft (1 m) above the seabed	5.4	1.7	0.2

* For the individual Inter-Array Cable and Offshore Export Cable, the horizontal distance is measured from the centerline of the cable. For the Offshore Export Cables in Trenchless Installation conduits, the maximum is measured over the center of the middle cable, but the horizontal distance is measured from the center over the right-side or left-side cable.

Table C-2. Calculated AC magnetic-field levels (mG) at specified horizontal distances from AC cables for peak loading

Cable	Voltage	Installation Type	Location	AC Magnetic Field (mG)		
				Max (0 ft)	±5 ft (±1.5 m)*	±10 ft (±3 m)*
Inter-Array Cable	66-kV	Buried (3.3 ft [1 m])	Seabed	68	8.8	0.4
			3.3 ft (1 m) above the seabed	5.2	1.6	0.1
		Mattress-Covered (1 ft [0.3 m])	Top of the protective cover	758	28.3	0.5
			3.3 ft (1 m) above the protective cover	28	5.3	0.3
Offshore Export Cable	230-kV	Buried (3.3 ft [1 m])	Seabed	112	15	0.7
			3.3 ft (1 m) above the seabed	8.7	2.7	0.2
		Mattress-Covered (1 ft [0.3 m])	Top of the protective cover	1146	33	0.9
			3.3 ft (1 m) above the protective cover	46	9.2	0.5
Offshore Export Cable: Trenchless Installation	230-kV	Buried (3.3 ft [1 m])	Seabed	112	16	0.7
			3.3 ft (1 m) above the seabed	8.7	2.8	0.3

* For the individual Inter-Array Cable and Offshore Export Cable, the horizontal distance is measured from the centerline of the cable. For the Offshore Export Cables Trenchless Installation conduits, the maximum is measured over the center of the middle cable, but the horizontal distance is measured from the center over the right-side or left-side cable.

Table C-3. Calculated AC electric-field levels (mV/m) at specified horizontal distances from AC cables for average loading

Cable	Voltage	Installation Type	Location	AC Magnetic Field (mG)		
				Max (0 ft)	±5 ft (±1.5 m)*	±10 ft (±3 m)*
Inter-Array Cable	66-kV	Buried (3.3 ft [1 m])	Seabed	0.5	0.1	<0.1
			3.3 ft (1 m) above the seabed	<0.1	<0.1	<0.1
		Mattress-Covered (1 ft [0.3 m])	Top of protective the cover	3.4	0.1	<0.1
			3.3 ft (1 m) above the protective cover	0.2	<0.1	<0.1
Offshore Export Cable	230-kV	Buried (3.3 ft [1 m])	Seabed	1.2	0.2	<0.1
			3.3 ft (1 m) above the seabed	0.1	<0.1	<0.1
		Mattress-Covered (1 ft [0.3 m])	Top of protective cover	7.8	0.4	<0.1
			3.3 ft (1 m) above the protective cover	0.5	0.1	<0.1
Offshore Export Cable: Trenchless Installation	230-kV	Buried (3.3 ft [1 m])	Seabed	1.2	0.2	<0.1
			3.3 ft (1m) above the seabed	0.1	<0.1	<0.1

* For the individual Inter-Array Cable and Offshore Export Cable, the horizontal distance is measured from the centerline of the cable. For the Offshore Export Cables in Trenchless Installation conduits, the maximum is measured over the center of the middle cable, but the horizontal distance is measured from the center over the right-side or left-side cable.

Table C-4. Calculated AC electric-field levels (mV/m) at specified horizontal distances from AC cables for peak loading

Cable	Voltage	Installation Type	Location	AC Magnetic Field (mG)		
				Max (0 ft)	±5 ft (±1.5 m)*	±10 ft (±3 m)*
Inter-Array Cable	66-kV	Buried (3.3 ft [1 m])	Seabed	1.1	0.2	<0.1
			3.3 ft (1 m) above the seabed	0.1	<0.1	<0.1
		Mattress-Covered (1 ft [0.3 m])	Top of protective the cover	7.8	0.3	<0.1
			3.3 ft (1 m) above the protective cover	0.5	0.1	<0.1
Offshore Export Cable	230-kV	Buried (3.3 ft [1 m])	Seabed	1.9	0.3	<0.1
			3.3 ft (1 m) above the seabed	0.2	0.1	<0.1
		Mattress-Covered (1 ft [0.3 m])	Top of protective cover	13	0.6	<0.1
			3.3 ft (1 m) above the protective cover	0.8	0.2	<0.1
Offshore Export Cable: Trenchless Installation	230-kV	Buried (3.3 ft [1 m])	Seabed	1.9	0.3	<0.1
			3.3 ft (1m) above the seabed	0.2	0.1	<0.1

* For the individual Inter-Array Cable and Offshore Export Cable, the horizontal distance is measured from the centerline of the cable. For the Offshore Export Cables Trenchless Installation conduits, the maximum is measured over the center of the middle cable, but the horizontal distance is measured from the center over the right-side or left-side cable.

Table C-5. Calculated AC electric-field levels (mV/m) induced in electrosensitive species for average loading

Cable	Voltage	Installation Type	Location	Induced AC Electric Fields (mV/m) in Electrosensitive Species	
				Dogfish	Sturgeon
Inter-Array Cable	66-kV	Buried (3.3 ft [1 m])	Seabed	0.19	0.36
			3.3 ft (1 m) above the seabed	0.01	0.03
		Mattress-Covered (1 ft [0.3 m])	Top of protective the cover	2.2	4.1
			3.3 ft (1 m) above the protective cover	0.08	0.15
Offshore Export Cable	230-kV	Buried (3.3 ft [1 m])	Seabed	0.45	0.84
			3.3 ft (1 m) above the seabed	0.03	0.07
		Mattress-Covered (1 ft [0.3 m])	Top of protective cover	4.6	8.7
			3.3 ft (1 m) above the protective cover	0.19	0.35
Offshore Export Cable: Trenchless Installation	230-kV	Buried (3.3 ft [1 m])	Seabed	0.45	0.84
			3.3 ft (1m) above the seabed	0.03	0.07

Table C-6. Calculated AC electric-field levels (mV/m) induced in electrosensitive species for peak loading

Cable	Voltage	Installation Type	Location	Induced AC Electric Fields (mV/m) in Electrosensitive Species	
				Dogfish	Sturgeon
Inter-Array Cables	66-kV	Buried (3.3 ft [1 m])	Seabed	0.44	0.83
			3.3 ft (1 m) above the seabed	0.03	0.06
		Mattress-Covered (1 ft [0.3 m])	Top of protective the cover	4.9	9.3
			3.3 ft (1 m) above the protective cover	0.18	0.34
Offshore Export Cable	230-kV	Buried (3.3 ft [1 m])	Seabed	0.73	1.4
			3.3 ft (1 m) above the seabed	0.06	0.11
		Mattress-Covered (1 ft [0.3 m])	Top of protective cover	7.4	14
			3.3 ft (1 m) above the protective cover	0.3	0.57
Offshore Export Cable: Trenchless Installation	230-kV	Buried (3.3 ft [1 m])	Seabed	0.73	1.4
			3.3 ft (1m) above the seabed	0.06	0.11

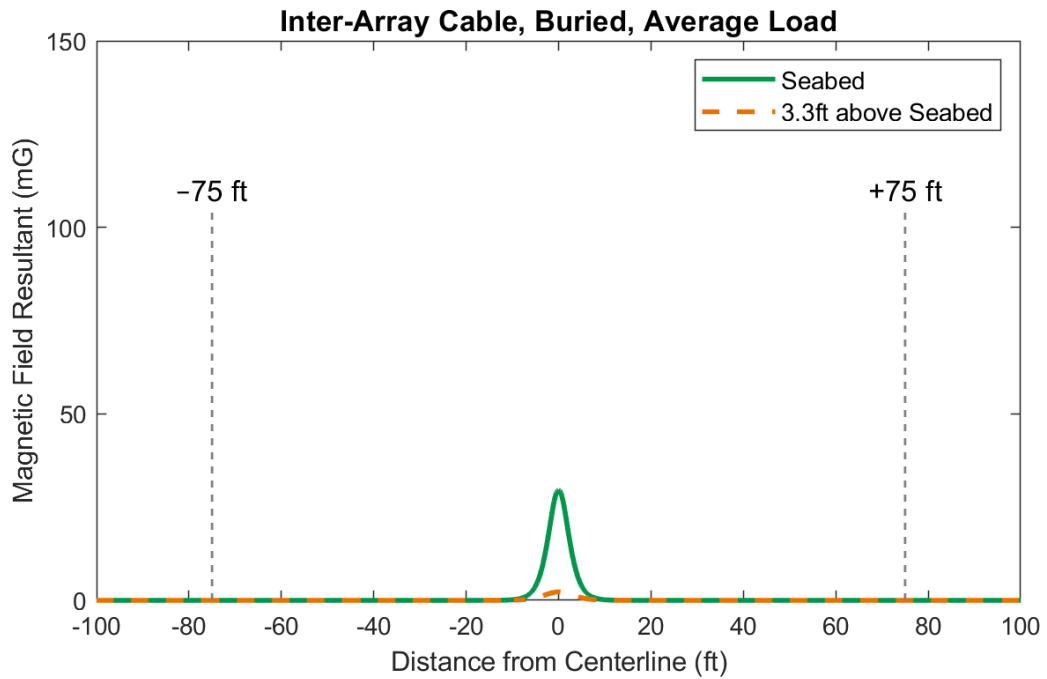

Figure C-4. Calculated magnetic-field levels in seawater above a 66-kV Inter-Array Cable for a 3.3-ft (1-m) burial depth and average loading.

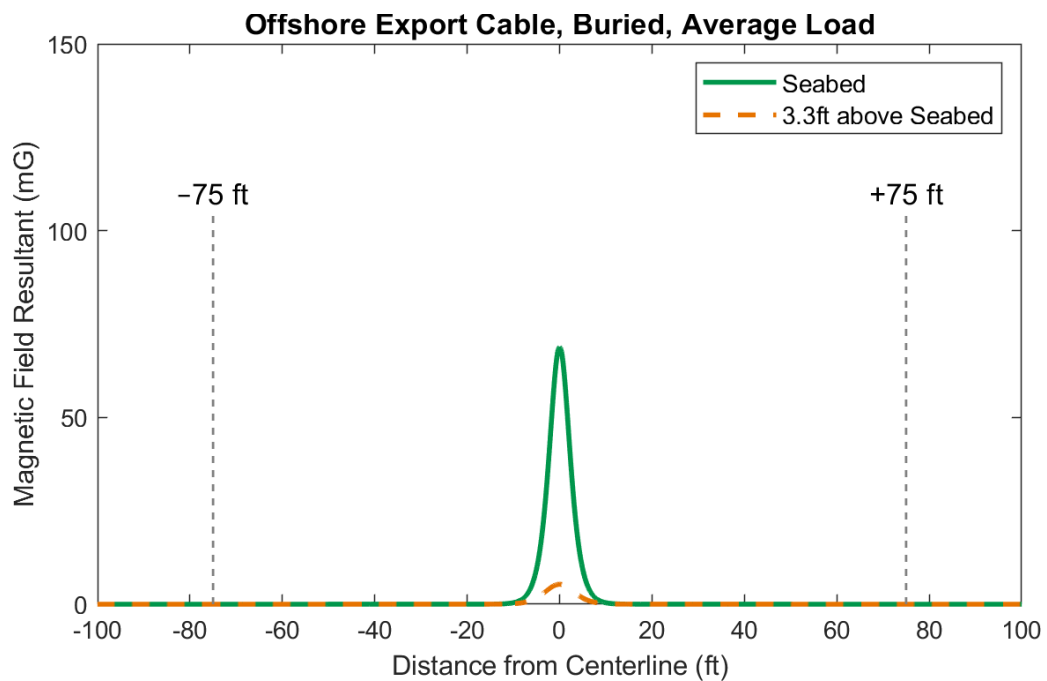

Figure C-5. Calculated magnetic-field levels in seawater above the 230-kV Offshore Export Cable for a 3.3-ft (1-m) burial depth and average loading.

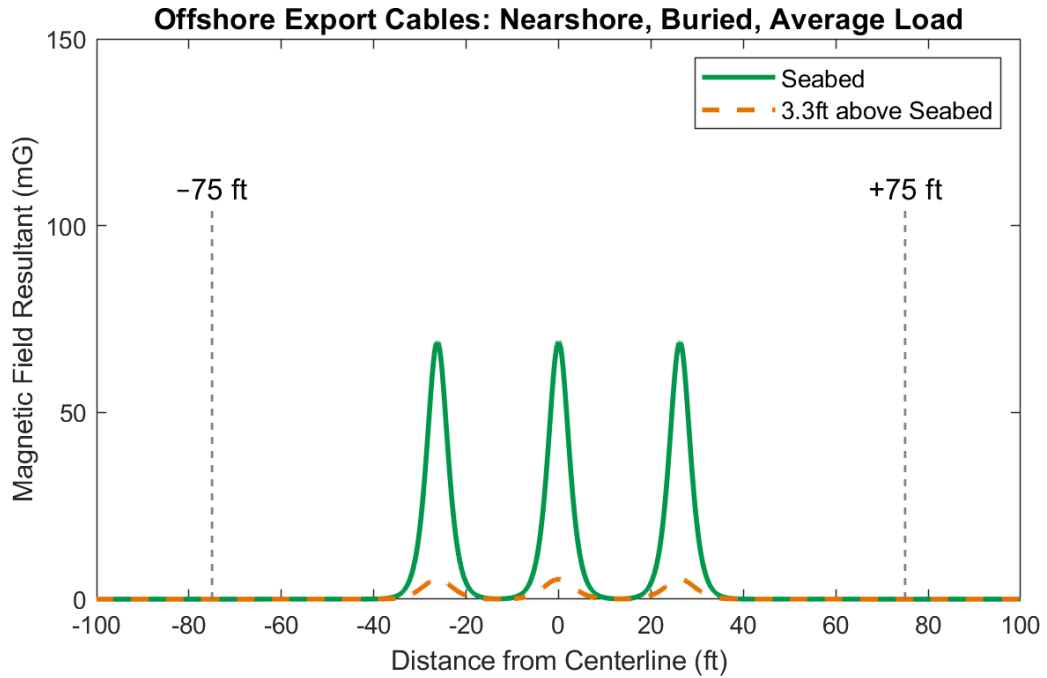

Figure C-6. Calculated magnetic-field levels in seawater above the 230-kV Offshore Export Cables in the nearshore Trenchless Installation conduits for a 3.3-ft (1-m) burial depth and average loading.

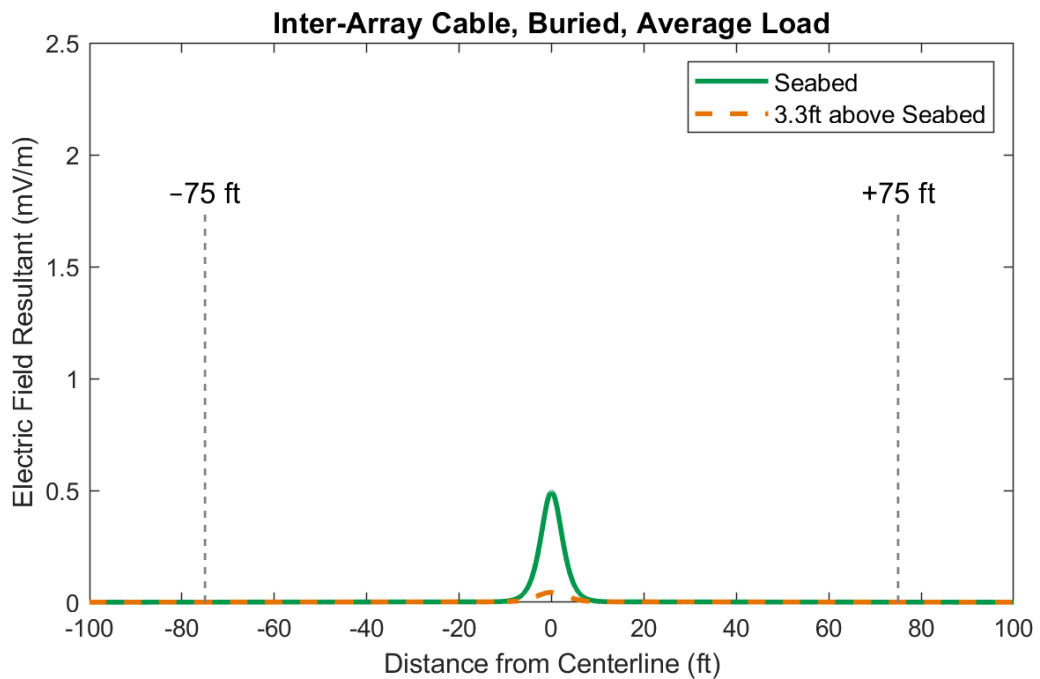

Figure C-7. Calculated induced electric-field levels in seawater above a 66-kV Inter-Array Cable for a 3.3-ft (1-m) burial depth and average loading.

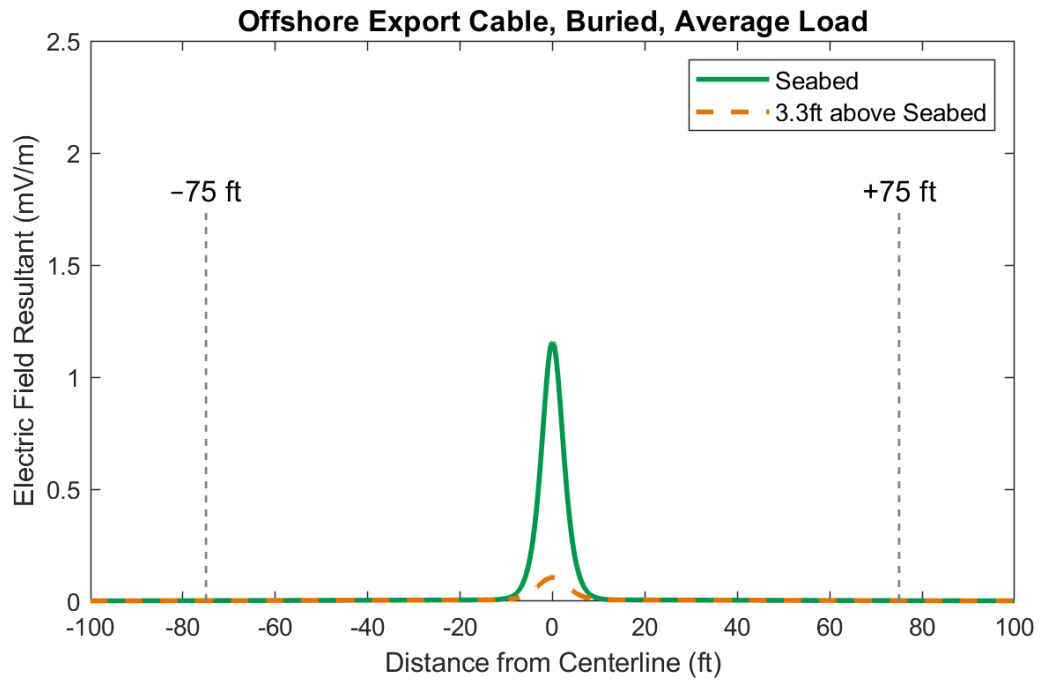

Figure C-8. Calculated induced electric-field levels in seawater above the 230-kV Offshore Export Cable for a 3.3-ft (1-m) burial depth and average loading.

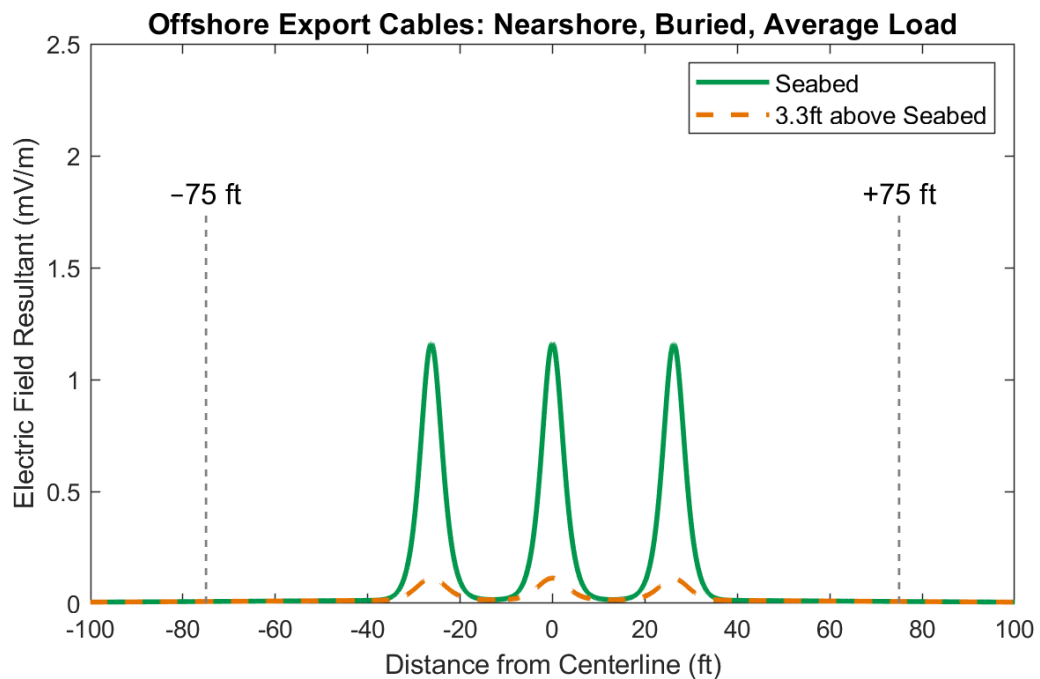

Figure C-9. Calculated induced electric-field levels in seawater above the 230-kV Offshore Export Cables in the nearshore Trenchless Installation conduits for a 3.3-ft (1-m) burial depth and average loading.

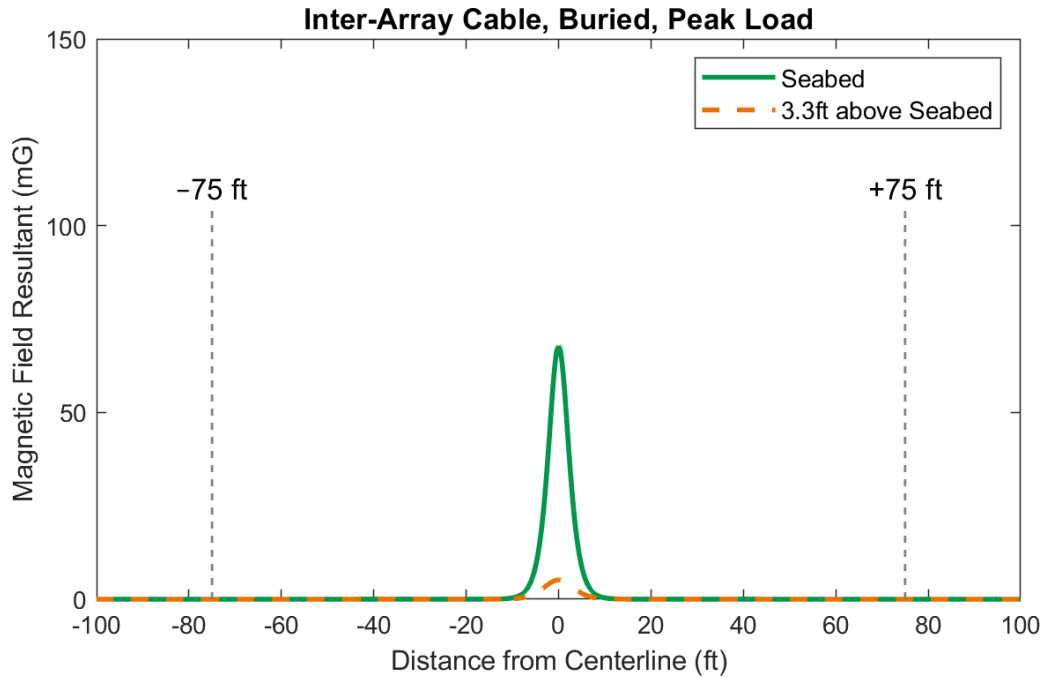

Figure C-10. Calculated magnetic-field levels in seawater above a 66-kV Inter-Array Cable for a 3.3-ft (1-m) burial depth and peak loading.

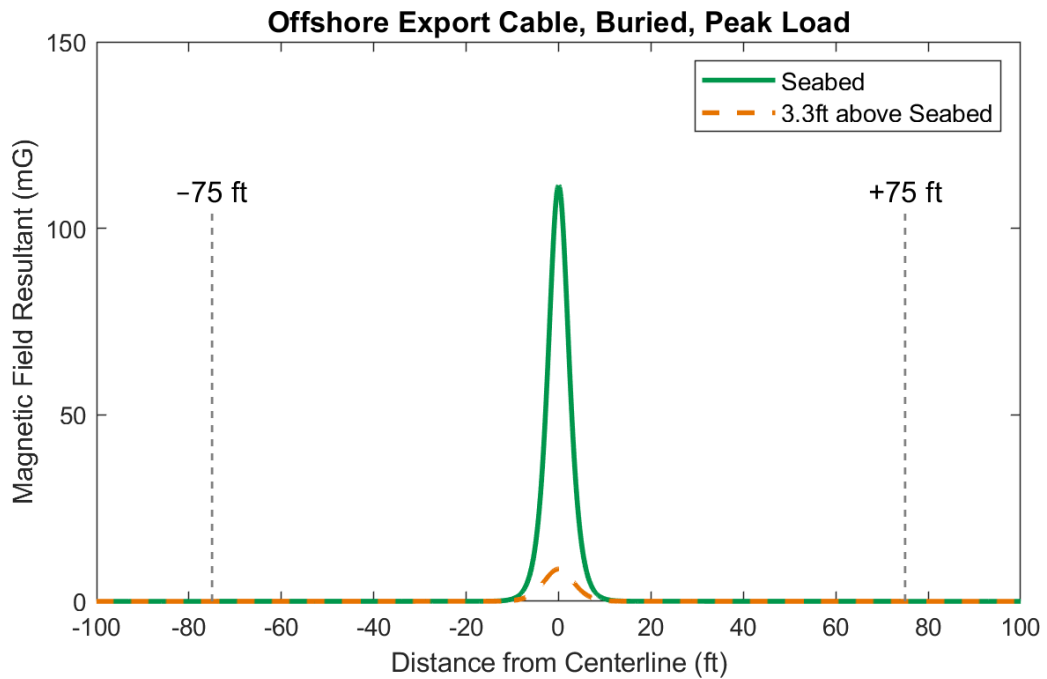

Figure C-11. Calculated magnetic-field levels in seawater above the 230-kV Offshore Export Cable for a 3.3-ft (1-m) burial depth and peak loading.

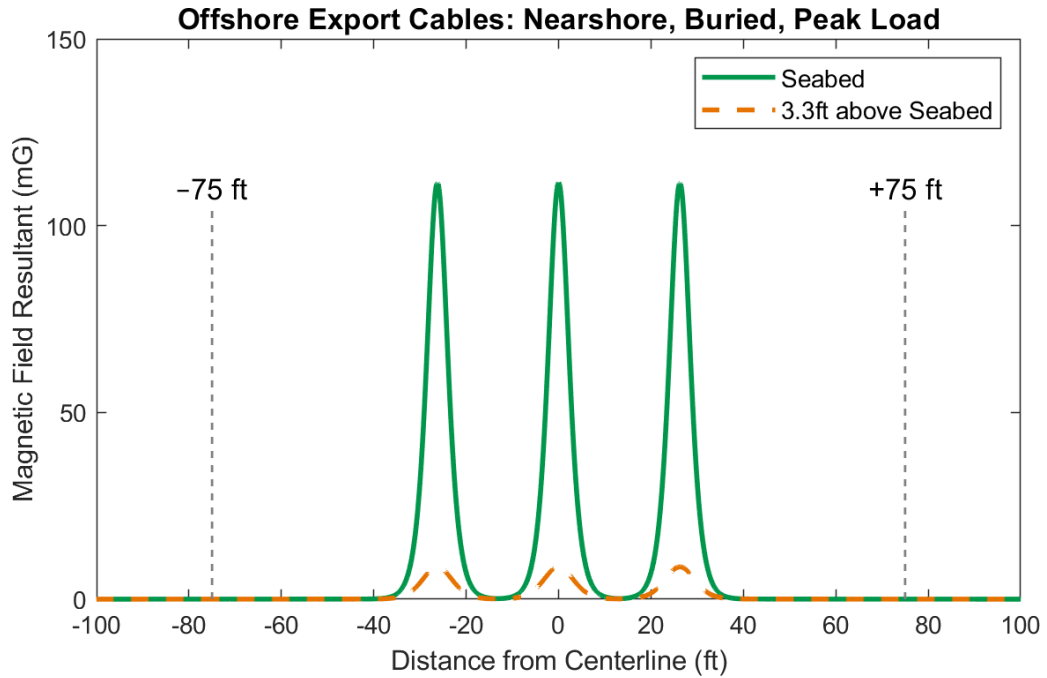

Figure C-12. Calculated magnetic-field levels in seawater above the 230-kV Offshore Export Cables in the nearshore Trenchless Installation conduits for a 3.3-ft (1-m) burial depth and peak loading.

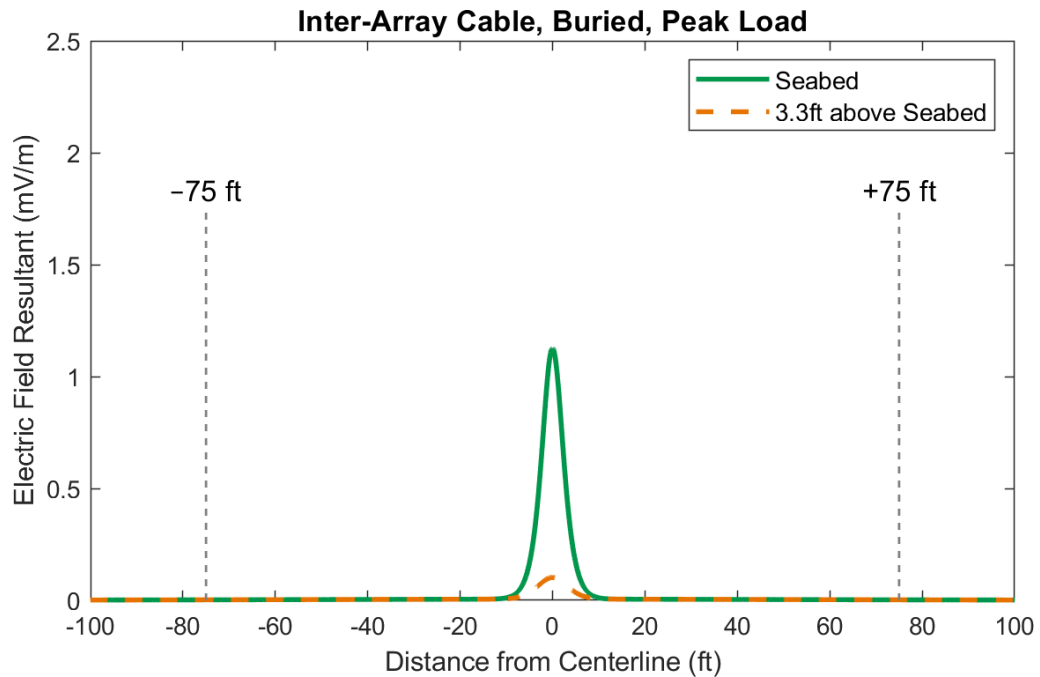

Figure C-13. Calculated induced electric-field levels in seawater above a 66-kV Inter-Array Cable for a 3.3-ft (1-m) burial depth and peak loading.

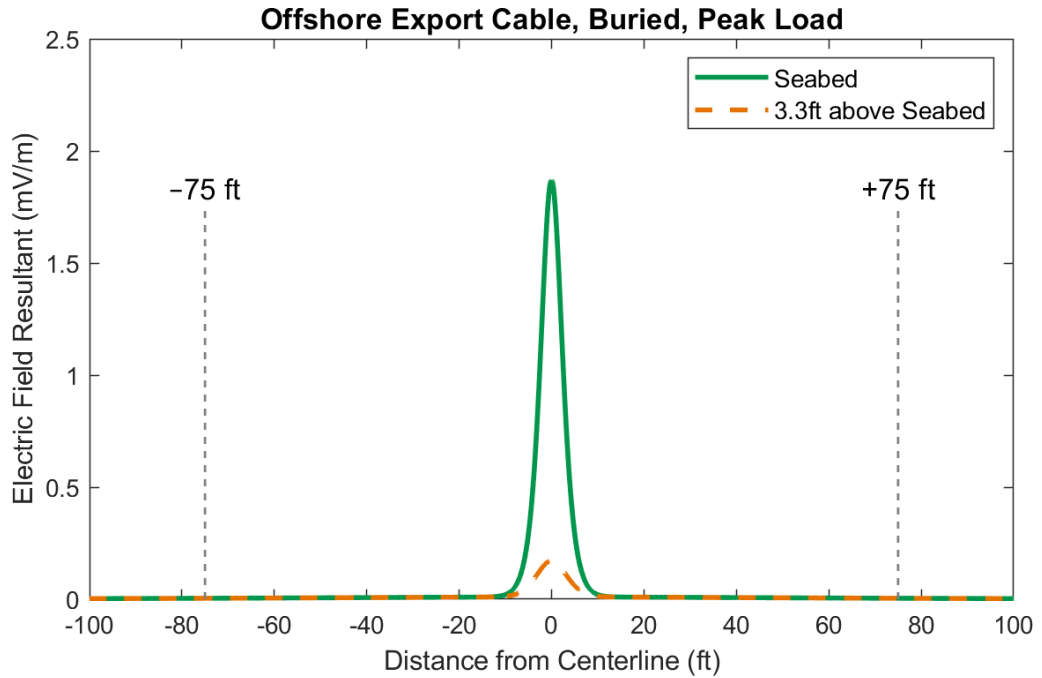

Figure C-14. Calculated induced electric-field levels in seawater above the 230-kV Offshore Export Cable for a 3.3-ft (1-m) burial depth and peak loading.

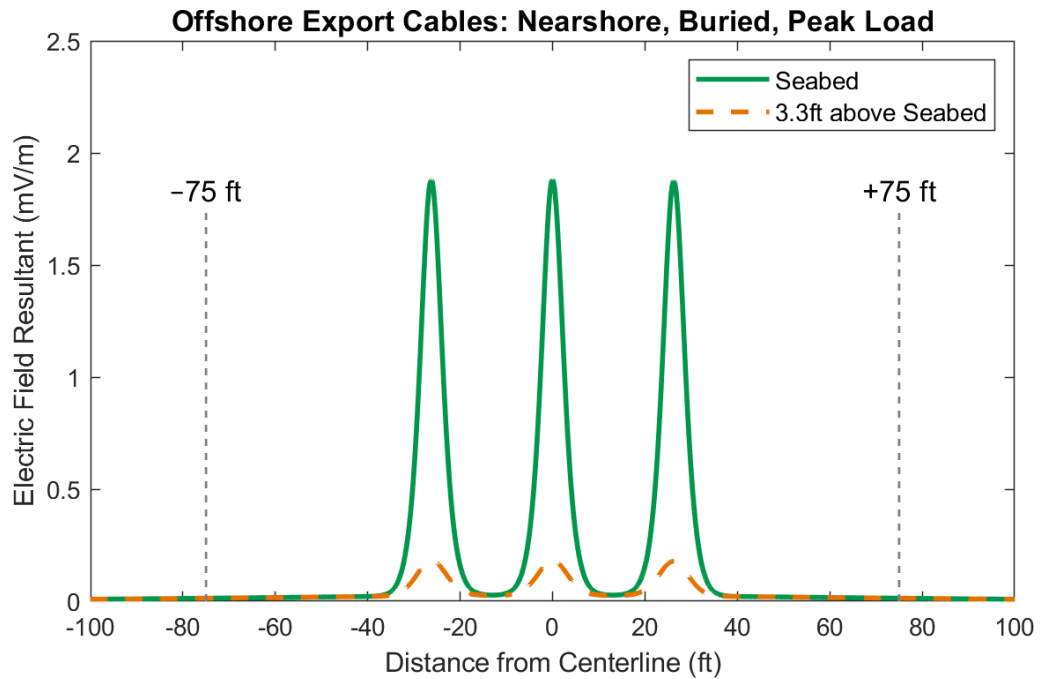

Figure C-15. Calculated induced electric-field levels in seawater above the 230-kV Offshore Export Cables in the nearshore Trenchless Installation conduits for a 3.3-ft (1-m) burial depth and peak loading.

Attachment D

Calculated Volume-Averaged EMF Levels for WTG, Offshore Substation, and Cables with Protective Coverings

WTG and Offshore Substations – Structure Configurations and Summary

The calculated magnetic field and induced electric fields in the previous sections represent the fields over the vast majority of the Offshore Project Area where the Inter-Array Cables and Offshore Export Cables carry power between other project elements (i.e., WTGs, Offshore Substation, and the shore landing). At the WTG and Offshore Substation installations, multiple cables converge and thus the combined effects of multiple cables on field levels were assessed by FEA modeling for the respective foundations. The structural configurations of the different installations are detailed in Attachment A. A summary of corresponding computed field strengths is detailed below. To assess the EMF levels experienced by marine species within manmade habitats created by the structure foundations, and by the protective mattresses or rock berms covering surface-laid cable, average magnetic and induced electric fields around the offshore installations were evaluated for various volumes of seawater where different marine species might spend more time than above buried cables in other locations.

WTG Foundation

The magnetic field from the cables on the WTG foundation is shown in Figure D-1 which is a 3D plot of the magnetic field across the entire modeling domain.¹⁸ A vertical plane cutting through the center of the plot passes through two Inter-Array Cables to show how the field level varies around the modeled cables. This figure also shows visually that the fields from one transmission cable are not calculated to substantially change the field levels at an adjacent cable. The maximum calculated field level over a single cable at the WTG (at the same specified distance from the cable) is within 1 percent of the maximum calculated field level listed above in Table C-2 (at similar distances from the cables).

¹⁸ The designs of the WTG and Inter-Array Cables were updated subsequent to the original assessment performed by Exponent. Field levels from the new design (smaller cables and lower loading) would be lower than the original design and modeling of the new design parameters was not performed.

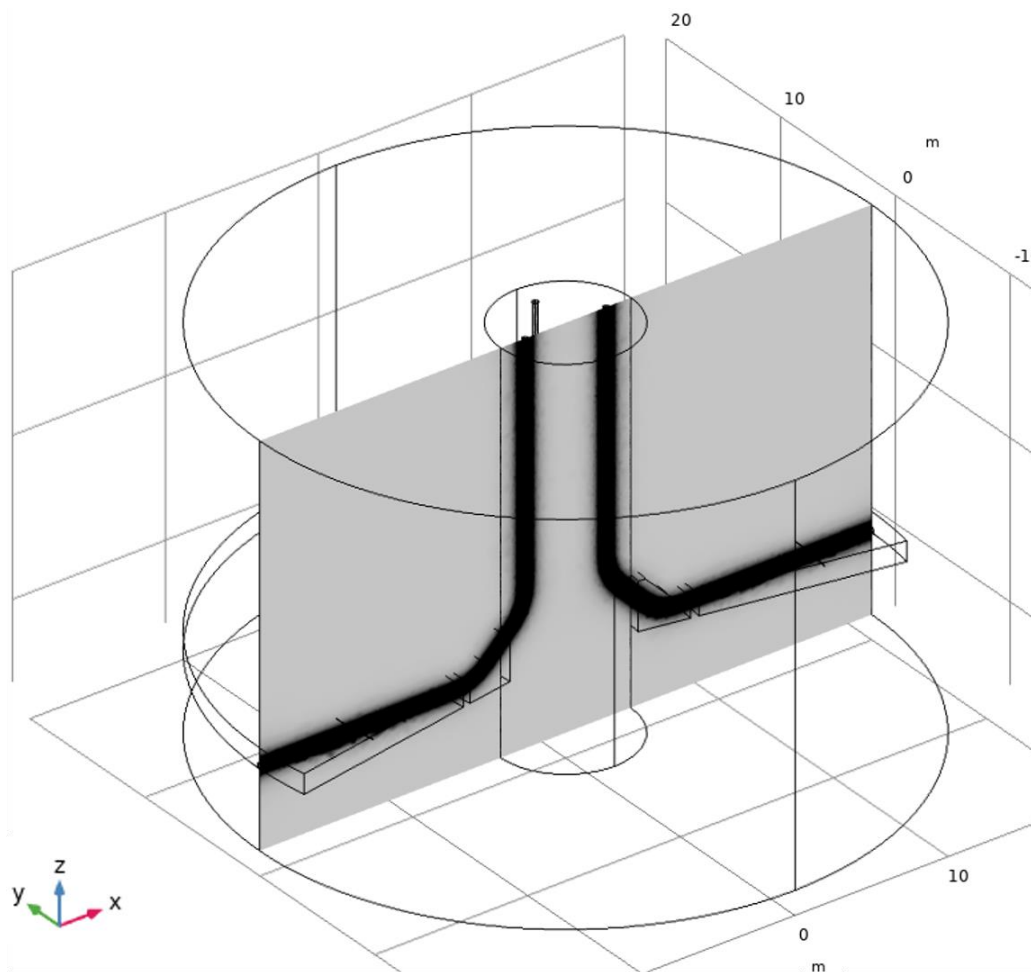

Figure D-1. Visualization of modeled magnetic fields around the Inter-Array Cables attached to the WTG. The density of the shading around two representative cables describes the relative strength of the calculated magnetic field.

The AC magnetic and induced electric fields around the WTG structure were assessed as volume averages within two regions representative of potential marine habitats. With reference to the Figure D-2 below, the volume shaded purple represents marine life swimming or crawling on top of the scour protection layer. A cross section of this volume extends from the top of the scour protection to a height of 3.3 ft (1 m) above the OD of the Inter-Array Cable and traverses the length of the scour protection for which the Inter-Array Cable lies flat. This volume arcs 200 degrees around the monopile foundation, encompassing all three Inter-Array Cables in the model.

The region representative of life that shelters above the scour protection and between the Inter-Array Cables and the monopile, referred to here as the skirt region, is shown in orange. This volume similarly arcs 200 degrees around the monopile foundation, encompassing all three Inter-Array Cables in the

model. The volume-averaged magnetic- and induced electric-field levels in these portions of the WTG are summarized in Table D-1.

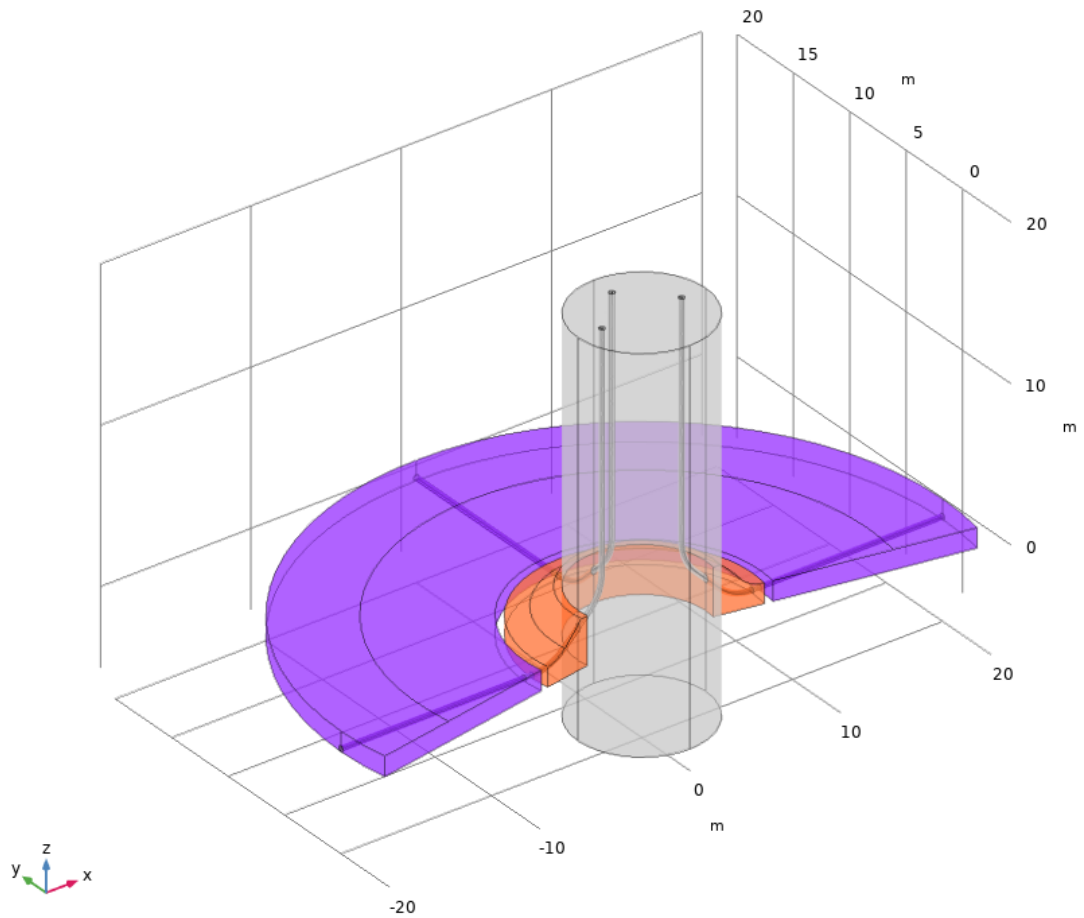

Figure D-2. Volumes over which AC magnetic- and induced-electric field levels are averaged at the WTG Foundation.

Table D-1. Calculated volume-averaged AC magnetic fields (mG) and electric fields (mV/m) around the WTG Foundation.

Volume of Water	WTG: Average Loading		WTG: Peak Loading	
	AC Magnetic-Field (mG)	AC Electric Field (mV/m)	AC Magnetic-Field (mG)	AC Electric Field (mV/m)
Inter-Array Cable – Above scour protection	22	0.24	50	0.56
Inter-Array Cable – Skirt region	52	0.56	120	1.28

Offshore Substation Foundation

A plane cutting through the center of the Offshore Export Cables on the east face of the jacket foundation in Figure D-3 illustrates how the calculated magnetic-field level varies around these modeled cables. Thus, this figure shows that although the Offshore Export Cables on the south face of the Offshore Substation and the Inter-Array Cables on the north and east faces of the Offshore Substations are closer together compared to the cables around the base of the WTG foundation, it still holds that fields from one transmission cable were not calculated to substantially change the field levels at an adjacent cable. That is, the field strength decreases rapidly with distance from each cable. The maximum calculated field level above the cables around the Offshore Substation Foundation is within 1 percent of the maximum field calculated for the case of equivalent individual straight cables evaluated at the same distance above these cables, as detailed in Attachment C.

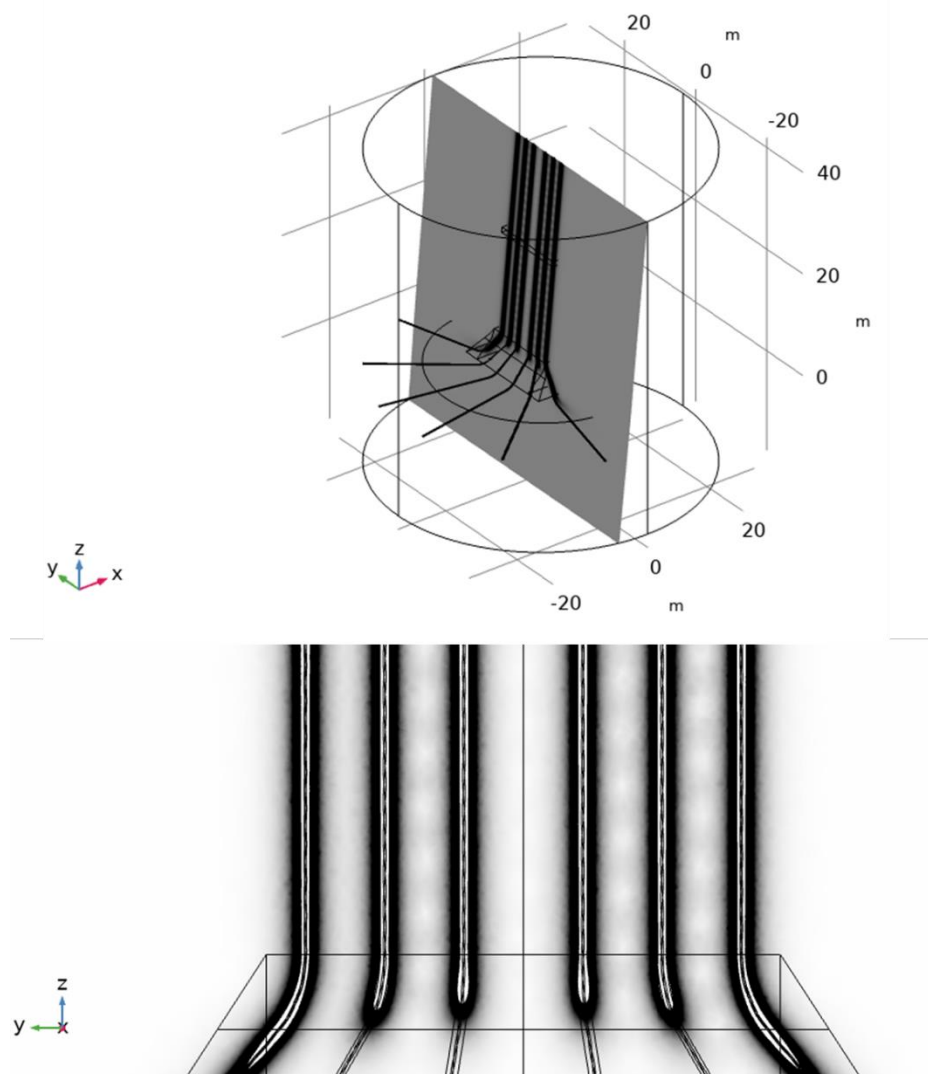

Figure D-3. A visualization from two perspectives of modeled magnetic fields around the Offshore Inter-Array Cables attached to the east face of the Offshore Substation foundation. The density of the shading around three Offshore Export Cables describes the relative strength of the calculated magnetic field.

The AC magnetic- and induced electric-fields around the Offshore Substation structure were assessed as volume averages within regions representative of marine habitats, as illustrated in Figure D-4 below. Each jacket-base region is represented by a volume that encompasses the set of current-carrying cables on a given side of the jacket structure. The volumes highlighted in orange represent regions where marine life that may swim or shelter among the collection of J-tubes where the tubes exit from the jacket structure, curve outward, and then enter the seabed. The volume encloses a region that extends vertically from where the J-tubes begin to curve outward from the structure down to the seabed and extends horizontally approximately 3.3 ft (1 m) from the cable's OD in the plane of the seabed. The volumes

highlighted in purple represent a region where marine life may swim among the collection of J-tubes in the water-column, where the cables are at the minimum center-to-center separation. The volume-averaged magnetic- and induced electric-field levels in these portions of the Offshore Substation foundation are summarized in Table D-2.

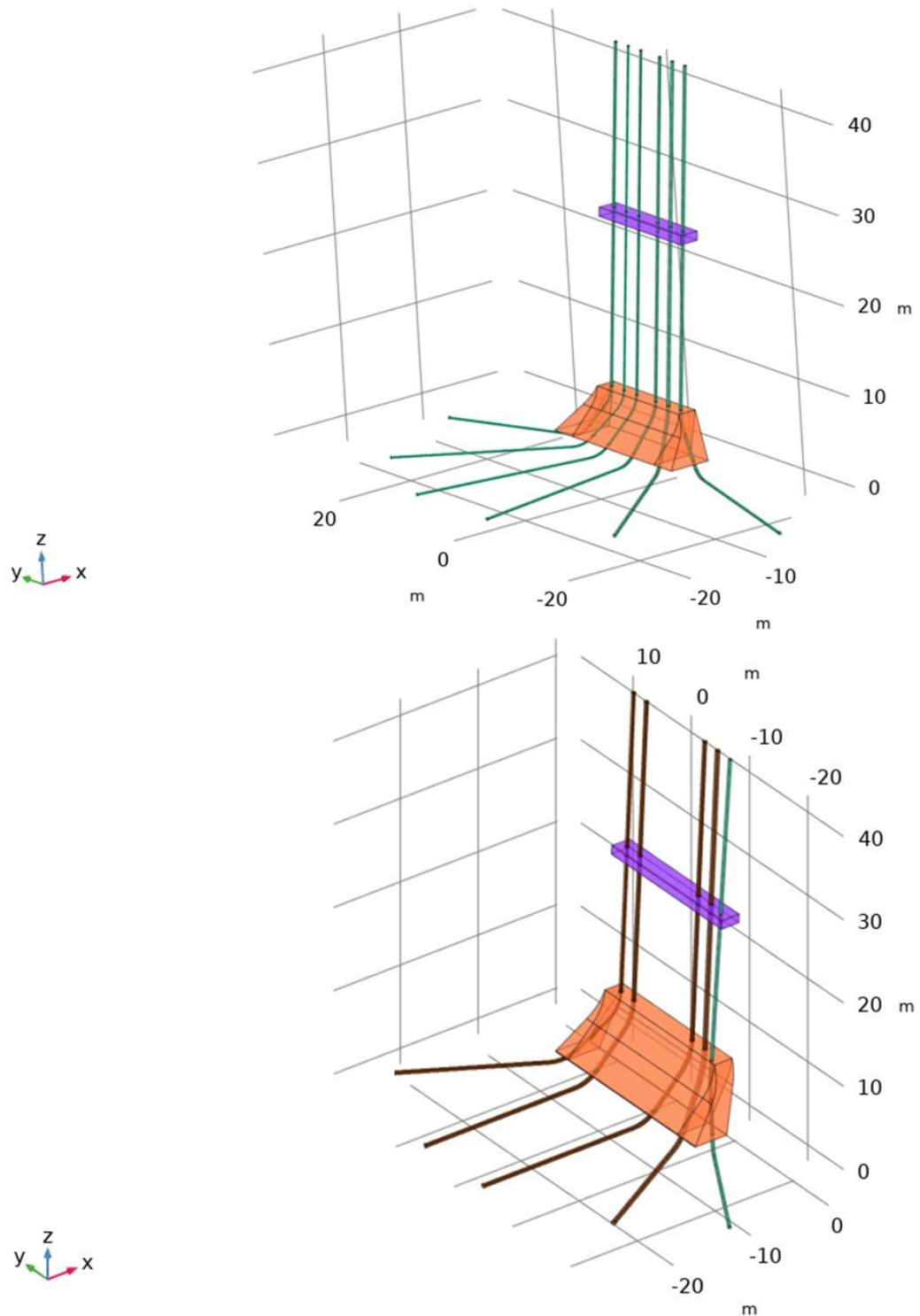

Figure D-4. Volumes over which AC magnetic- and induced-electric field levels are averaged at the Offshore Substation Foundation. The top figure shows the east face while the bottom figure illustrates the south face of the OSS. Green lines represent Inter-Array Cables and brown lines represent Offshore Export Cables.

Table D-2. Calculated volume-averaged AC magnetic fields (mG) and induced electric fields (mV/m) around the Offshore Substation Foundation.

Volume of Water	Offshore Substation: Average Loading		Offshore Substation: Peak Loading	
	AC Magnetic-Field (mG)	AC Electric Field (mV/m)	AC Magnetic-Field (mG)	AC Electric Field (mV/m)
Offshore Substation – east face at base	89	0.96	181	1.95
Offshore Substation – south face at base	126	1.52	209	2.51
Offshore Substation – east face at water column	126	1.34	256	2.70
Offshore Substation – south face at water column	141	1.71	235	2.82

Cables with Protective Covering

The results of AC magnetic and induced electric fields for the bulk of the cables that are wholly buried are reported in Attachment C. Volume-averaged magnetic fields and induced electric fields were calculated, however, to account for some marine organisms may congregate in the area over hard ground provided by protective coverings, such as protective mattresses or rock berms covering isolated surface laid cables. The volume over which these calculations were averaged corresponds to a region within a 3.3-ft (1-m) cube, extending vertically from the top of the protective covering. The volume-averaged calculations are shown in Table D-3 below.

Table D-3. Calculated volume-averaged AC magnetic-fields (mG) and electric-fields (mV/m) above cables with protective covers.

Volume of Water*	Average Loading		Peak Loading	
	Magnetic-Field (mG)	Electric Field (mV/m)*	Magnetic-Field (mG)	Electric Field (mV/m)
Inter-Array Cable	66	0.92	151	2.11
Offshore Export Cable	150	2.15	243	3.48

* Volume corresponds to a 3.3-ft (1-m) sided cube above circuit centerline; that is, a cube above the center of the Inter-Array Cable or the Offshore Export Cable.