



*Fueling our future, naturally.*

*RESPONSE TO THE “CALL FOR  
INFORMATION AND NOMINATIONS  
FOR COMMERCIAL LEASING FOR  
WIND POWER ON THE OUTER  
CONTINENTAL SHELF IN THE NEW  
YORK BIGHT”*



US WIND, INC. 1 North Charles Street, Baltimore, MD 21201



To  
**Bureau of Ocean Energy Management**  
Office of Renewable Energy Programs  
45600 Woodland Road  
(VAM – OREP)  
Sterling, Virginia 20166

Baltimore, July 25<sup>th</sup>, 2018

**Re: US Wind Inc. (AEAU Company No. 15023): Qualification Documents of US Wind Inc. for Commercial Leasing for Wind Power on the Outer Continental Shelf in the New York Bight – In Response to BOEM’s Call for Information and Nominations (Call) [Docket No. BOEM-2018-0004]**

Dear Sir or Madam:

We hereby submit the nomination and the related qualification documents of US Wind Inc. in response to the proposed notice (the “**Notice**”) for Commercial Leasing for Wind Power on the Outer Continental Shelf Offshore New York Bight made by the Bureau of Ocean Energy Management (hereinafter “**BOEM**”). That in order to express US Wind Inc. interest in participating in the sale of commercial wind leases on the Outer Continental Shelf (OCS) offshore New York.

All capitalized terms used but not defined herein shall have the meanings ascribed thereto in the Notice.

In accordance with the Required Nomination Information set forth in the Notice and in § 585.214 of the Renewable Energy Program Regulations (30 CFR 585), and in declaring its interest in the Call Areas, US Wind Inc. has enclosed the following documents and/or information:

1. **Identification of Lease Area.** The description of the Call Areas that US Wind Inc. plans to lease, which description includes the BOEM Protraction name, number and specific whole or partial OCS blocks or sub-blocks within the Call area.
2. **Objectives.** A description of US Wind’s objectives and the facilities that it will use to achieve those objectives, including the following descriptions:
  - A. **Devices and Infrastructure.** A description of the devices and infrastructure that will most likely be involved in US Wind’s wind farm project;
  - B. **Anticipated Power Production.** Information concerning the anticipated estimated power production of the wind farm;
  - C. **Likely Power Purchasers and Likely Procurement Approach.** Information concerning the power procurement opportunities in the New York Bight Area;

- D. Assessment of Ports and Infrastructure.** Information on the available options for manufacturing facilities and staging areas in New York. US Wind collected the public documents and, based on the local U.S. experience developed on the Maryland Project, went a step further refining down to two sites the potential options with further investigations needed for a third potential alternative;
- E. Benefits and Cost-Reductions from Offshore Wind.** An analysis of the various potential benefits coming from developing an offshore wind farm off the coast of New York.
- F. JEDI Model Cost-Benefit Analysis.** An analysis through the Jobs and Economic Development Impact (“JEDI”) tool developed by the National Renewable Energy Laboratory (“NREL”) providing a site-specific estimation of jobs and economic activity over the installation and O&M lifetime of the wind farm.
- G. A Statement that the Proposed Activities Conforms with State and Local Energy Planning Requirements, Initiatives or Guidance.** A statement that US Wind’s proposed wind farm would conform with State and Local Energy Planning Requirements, Initiative or Guidance.
3. **Schedules.** Preliminary development schedule and EPC schedule of proposed activities, including those leading to commercial operations.
4. **Available and pertinent data and information concerning renewable energy resources and environmental conditions in the area that US Wind wishes to lease, including energy and resource data and information used to evaluate the Call Area.** A report prepared by US Wind containing a description of available and pertinent data and information concerning renewable energy resources and environmental constraints in the Call Areas. The goal of the document is to find the area providing minimal impacts on the other users of the ocean, with minimal construction and operational costs, and highest energy production.
5. **Qualifications.** Documentation demonstrating that US Wind Inc is legally qualified to hold a lease, as set forth in 30 CFR 585.106 and 585.107(c). A copy of BOEM’s determination that US Wind is legally qualified to hold an offshore lease and that it has been assigned AEAU Company Number 15023.
6. **Technical and Financial Qualifications.** Documentation demonstrating that US Wind Inc is technically and financially capable of constructing, operating, maintaining and decommissioning the facilities described in (2) above, as set forth in 30 CFR 585.107(a).

If you have any questions or need any additional information, please contact the following:

**US Wind Inc.**

*Attention of Paolo Sammartino*  
410 Viale Abruzzo no. 410  
Chieti, Italy 66100  
[p.sammartino@renexia.it](mailto:p.sammartino@renexia.it)

With a copy to:

**US Wind Inc.**

Francesco Onorio  
1 N Charles Street, Suite 2310  
Baltimore, MD 21201  
[f.onorio@uswindinc.com](mailto:f.onorio@uswindinc.com)

Sincerely,

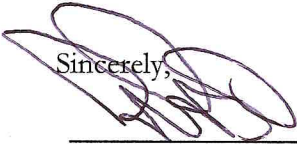

---

**US Wind Inc.**

*Riccardo Toto*  
(President)





# IDENTIFICATION OF THE LEASE AREA

**IDENTIFICATION OF OCS LEASE BLOCKS OF INTEREST**

US Wind Inc. plans to construct an offshore wind farm on the Outer Continental Shelf (OCS) offshore of the State of New York. The wind farm, sometimes referred to herein as “Sole Lot,” has been sited in order to optimize and facilitate construction and development activities, and to minimize adverse environmental and social impacts. Identification of the proposed OCS lease blocks of interest for Sole Lot, including all buffer areas, is provided in **Table 1**.

Area of Interest	Protection Number	Block Number	Sub Block
Hudson South	NJ18-03	7006	F
		7006	J
		7006	K
		7006	L
		7006	N
		7006	O
		7006	P
		7056	All
		7007	M
		7057	A
		7057	B
		7057	E
		7057	F
		7057	G
		7057	I
		7057	J
		7057	K
		7057	L
		7057	M
		7057	N
		7057	O
		7057	P
		7058	M
		7107	All
		7108	A
		7108	B
		7108	E
		7108	F
		7108	G
		7108	I
		7108	J
		7108	K
		7108	L
		7108	M
		7108	N
		7108	O
7108	P		
6008	All		
6009	A		

*US Wind, Inc. – Nomination for Commercial Leasing for Wind Power on the Outer Continental Shelf in New York Bight in Response to BOEM’s Call for Information and Nominations*

	6009	B
	6009	C
	6009	E
	6009	F
	6009	G
	6009	H
	6009	I
	6009	J
	6009	K
	6009	L
	6009	M
	6009	N
	6009	O
	6009	P
	6059	All
	6060	A
	6060	B
	6060	C
	6060	E
	6060	F
	6060	G
	6060	H
	6060	I
	6060	J
	6060	K
	6060	L
	6060	M
	6060	N
	6060	O
	6060	P
	6061	I
	6061	M
	6061	N
	6109	All
	6110	All
	6111	A
	6111	B
	6111	C
	6111	E
	6111	F
	6111	G
	6111	H
	6111	I
	6111	J
	6111	K
	6111	L
	6111	M
	6111	N

US Wind, Inc. – Nomination for Commercial Leasing for Wind Power on the Outer Continental Shelf in New York Bight in Response to BOEM’s Call for Information and Nominations

		6111	O
		6111	P
		6160	All
		6161	All

The OCS Lease Blocks of interest shown in two distinct clusters for the purposes of siting wind turbine generators with respective electrical interconnection systems are depicted in [Figure 1](#).

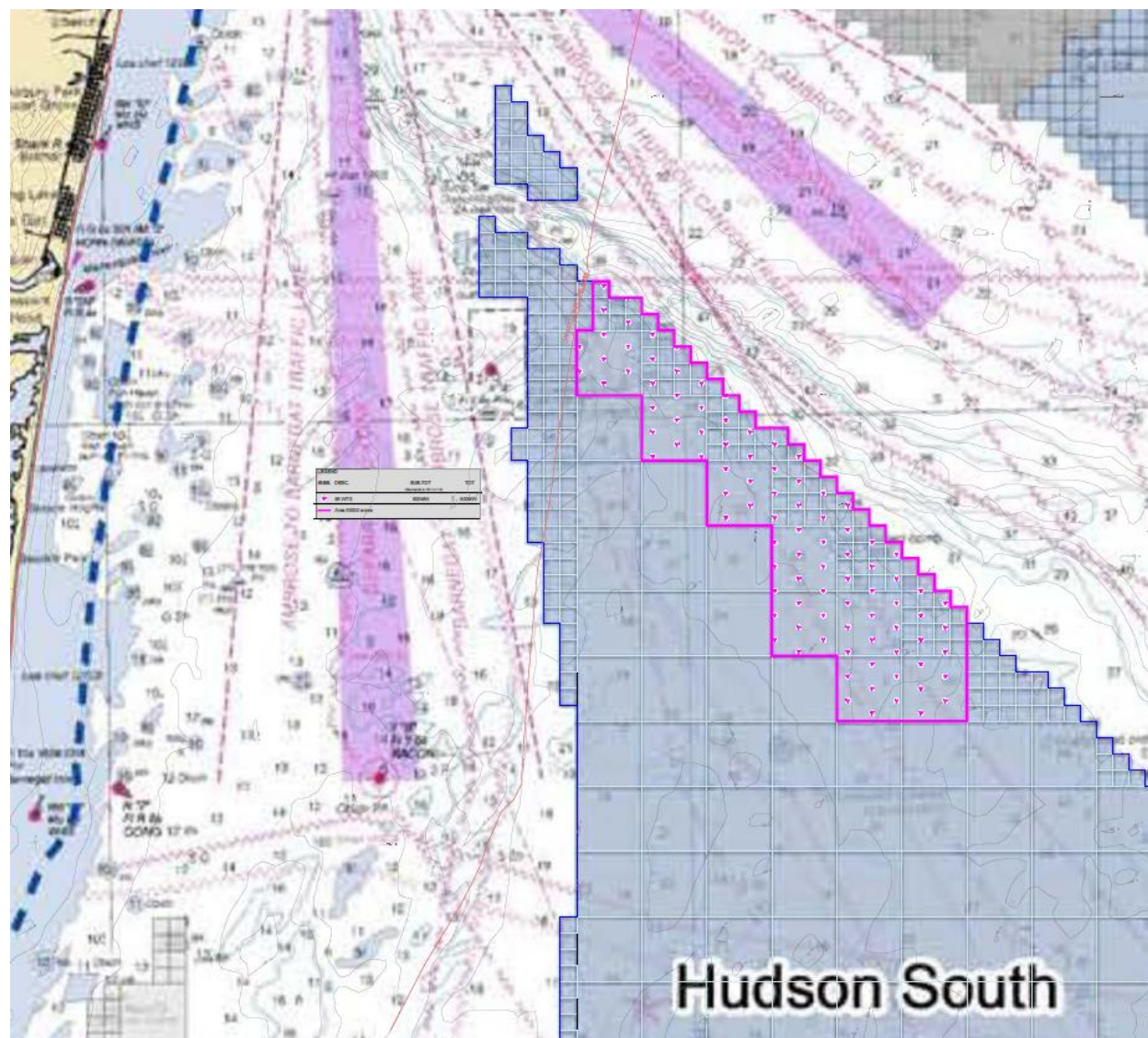

Figure 1 – OCS Lease Blocks of Interest for Commercial Development

The following figure is a zoom on the nominated area.

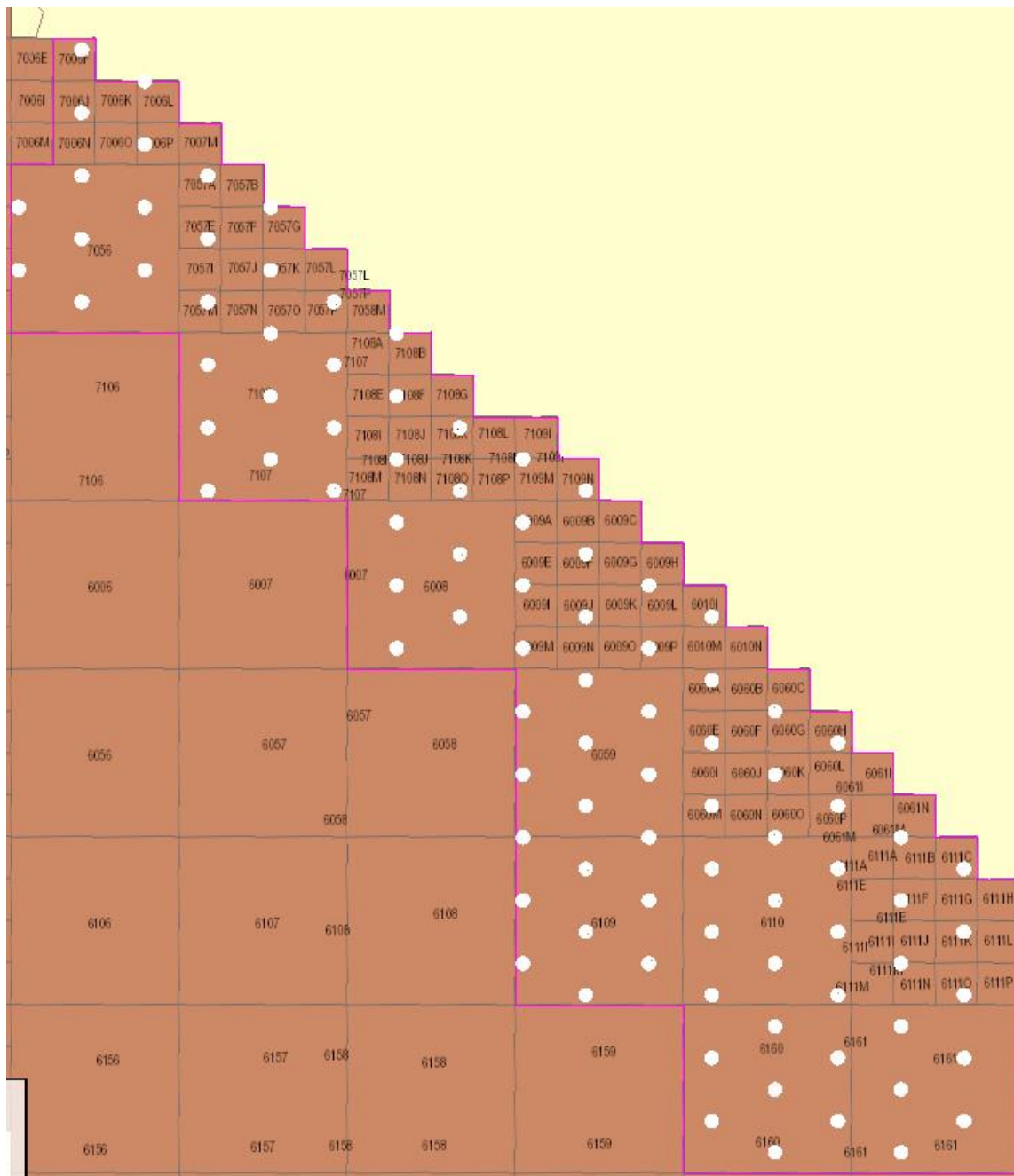

Figure 2 – Zoom on the nominated area

Total Number of Wind Turbine Generators Contemplated: 81 (Siemens 8.4 with 167-meter rotor diameter) + 15 (Siemens 8.0 with 167-meter rotor diameter).

Nameplate capacity of generation facility (installed): 800 MW.

Footprint of the occupation: 323 km<sup>2</sup> (80,000 acres).



# OBJECTIVES

## INTRODUCTION

US Wind, Inc is proud to provide a response to BOEM’s Call for Information and Nominations for commercial leasing for wind power on the OCS in New York Bight.

New York has set its sights on the offshore wind development, recognizing the enormous potential of renewable energy resources available off of its Atlantic coast. During his 2017 State of the State Address, Governor Cuomo set an ambitious goal of 2,400 MW by 2030, enough to power up to 1.2 million households in New York. And to position New York as the leading offshore wind market in the USA, creating high quality jobs, clean energy, and reduced costs, Governor Cuomo called for New York State to procure at least 800 MW of offshore wind power between two solicitations to be issued in 2018 and 2019, equivalent to enough energy to power 400,000 New York households.

This Call for Information and Nomination (“**CIN**”) follows a request issued by the State of New York to the U.S. Bureau of Ocean Energy Management (BOEM) to create and lease at least four new Wind Energy Areas (“**WEAs**”). In that request, the State recommended those areas that, after extensive analysis, resulted in being the most promising for the development of projects that could serve New York.

## OBJECTIVES

The objectives of this Response to BOEM’s CIN are:

1. Propose a nameplate capacity to contribute to NY’s goal of 2,400 MW by 2030;
2. Identify the most favorable area for potential offshore wind development;
3. Identify the likely power purchasers and likely power procurement approach;
4. Identify and describe the best available technologies to be used for the development of the proposed nameplate capacity;
5. Identify the suitable ports and infrastructures;
6. Demonstrate benefits and cost-reductions coming from offshore wind development off the NY coast;
7. Demonstrate the specific benefits of a potential future 800 MW offshore wind farm developed by US Wind through a site-specific JEDI Model analysis.

## THE PROPOSED NAMEPLATE CAPACITY

The proposed nameplate capacity is 800 MW. The proposed size is consistent with BOEM’s recommendations included in the 83 FR 15602 document; indeed, BOEM would consider the nomination of a block of approximately 80,000 acres, as it would likely be able to support 800 MW wind energy facility (assuming a power density ratio of 0.01 MW per acre). The approach adopted by BOEM is consistent with State of New York’s request to BOEM to identify four 800 MW lease areas.

US Wind proposes to develop a single season with 800 MW or two separate seasons by 400 MW each. This approach is consistent with the base deployment profile evaluated in the document “*Offshore Wind Policy Options Paper*” developed by New York State Energy Research and Development Authority (“**NYSERDA**”) submitted on January 29, 2018. This approach is also consistent with the State of New York Public Service Commission, case document 18-E-0071, “*Order Establishing Offshore Wind Standard and Framework for Phase 1 Procurement*”.



## THE NOMINATED AREA

Consistent with the above target nameplate, US Wind selected an area suitable for supporting 800 MW of offshore wind generation. The nominated area has been evaluated through multiple criteria identified in BOEM’s 83 FR 15602 document, such as:

- Fisheries;
- Avian Species;
- Marine Protected Species;
- Navigation;
- DoD and USCG;
- Bathymetric conditions;
- Visual impacts;
- Cables and other existing infrastructures.

US Wind Inc assessed all the information available, relying heavily on the powerful tool developed by the Northeast Regional Ocean Council (“**NROC**”). This tool was launched in 2012 to support development and implementation of the Northeast Ocean Plan.

Additionally, the area has been sited to achieve the maximum energy production and the minimum CapEx and OpEx costs. The cost assessment has been based on the document “*Offshore Wind Policy Options Paper*” developed by New York State Energy Research and Development Authority (“**NYSERDA**”), already mentioned before.

Further information about the nominated area is included in US Wind’s application document “*Identification of the Lease Area*”.

## LIKELY POWER PURCHASERS AND LIKELY PROCUREMENT APPROACH

There are multiple opportunities coming from an offshore wind energy area. US Wind nominated area is perfectly positioned to serve the ambitious plan set by the New York State.

There are also multiple procurement approaches that can be adopted, such as the Fixed OREC and Index OREC included in the Order Case 18-E-0071. In general, each approach has pros and cons, as defined in the Option Papers and US Wind is open to any procurement approaches.

Additional information on the above can be found in the specific document “*Likely Power Purchasers and Likely Procurement Approach*”.

## BEST AVAILABLE TECHNOLOGIES

US Wind is in advanced development stage on the Maryland Project (“**MarWin**”) and is one of the two companies to have received an OREC award in Maryland. US Wind used this experience in U.S. offshore wind to define the best technologies to be used on the proposed New York Wind Farm.

The Nomination documents mentioned above are the result of detailed analysis performed by an experienced senior team and the many interactions had with the supply chain companies involved on the Maryland project.

Further information on the technologies used (i.e. foundations, turbines, cables, etc.) is detailed in the documents included in this application.

## PORTS AND INFRASTRUCTURE

US Wind assessed the ports and infrastructure available to support the development of the proposed offshore wind generation facility. The assessment was based on the experience developed on the MarWin Project and the information included in document “*New York State Offshore Wind Master Plan – Assessment of Ports and Infrastructure*” developed by COWI North America for NYSERDA.

The study prepared by COWI identified and investigated 54 distinct waterfront sites in New York Harbor and along the Hudson River, as well as 11 distinct areas along the coast of Long Island.

US Wind used the information provided in the document to assign a score to a shortlist of locations. Red Hook Brooklyn at New York Harbor, Military Ocean Terminal at Bayonne, and South Brooklyn Marine Terminal resulted in being the most suitable candidates for supporting the offshore wind development.

Further information on this assessment can be found in the document “*Ports and Infrastructure*” included in this application.

## BENEFITS AND COST-REDUCTIONS IN OFFSHORE WIND DEVELOPMENT

In common with other clean sources, offshore wind power can help to build a diversified and geographically distributed U.S. energy mix, offering protection against many potential energy supply emergencies, whether natural or man-made. The United States has an enormous potential in offshore wind energy resources, estimated at four times the nation’s present electricity capacity.

US Wind evaluated the environmental, electricity system, and socioeconomic benefits coming from developing offshore wind.

Further information on the above can be found in the document “*Benefits and Cost-Reductions from Offshore Wind*”.

## JEDI MODEL COST-BENEFIT ANALYSIS

US Wind conducted a Jobs and Economic Development Impact (“**JEDI**”) analysis for the evaluation of the impacts coming from the proposed 800 MW generation facility. This tool has been developed by the National Renewable Energy Laboratory (“**NREL**”) and is an input-output spreadsheet-based model. JEDI uses state-specific multipliers for employment, earnings, and output (economic activity) from IMPLAN.

The objective of this analysis is to find specific jobs and economic activity information resulting from the proposed facility. The analysis is based on US Wind’s knowledge of the market, the experience developed in more than 3 years of development on the MarWin Project, and the many discussions entertained with tier 1 and tier 2 suppliers, from both the United States and Europe.

The outcome of the analysis is then compared with the publicly available information on the estimated workforce development in New York coming from the future offshore wind industry.

Further information on the analysis can be found in the “*JEDI Model Cost-Benefit Analysis*” document.



# FOUNDATIONS

## INTRODUCTION

The turbine foundations and the support structures must be able to securely support the vertical load of the Wind turbine itself as well as withstand the loads coming from Wind and marine environment. Additionally, they must be able to guarantee safe access and working environment for the maintenance and the operational activities. As such, in determining the most appropriate turbine foundation, US Wind evaluated several design criteria, including:

- Water depth;
- Soil conditions;
- Turbine loads;
- Wind loads;
- Wave loads;
- Supply chain risk (distance to production facility);
- Steel (or concrete) price fluctuations;
- Vessel availability;
- Vessel pricing fluctuations;
- Other (e.g. installation requirements).

The structural solutions evaluated were:

- Monopiles;
- Twisted Jackets (Inward Battered Guide Structures, IBGS);
- Jacket foundations;
- Suction buckets;
- Gravity-based foundations.

## SELECTED SOLUTION

The jacket is one of the most commonly used solutions for offshore structures and has been used for decades for both offshore wind and, especially, oil & gas industry.

Another common option is the monopile. The monopile foundation consists of a steel pile with diameters of around 6 m. The pile is expected to be piled between 25 to 30 m into the seabed, depending upon the site-specific conditions. Monopiles require almost no seabed preparation. When installed, a filter layer will be placed to avoid scouring around the base after driving the monopile. A jack-up barge is normally used.

Water depths and wind turbine generator to be mounted on top of the transition piece are two critical factors in deciding which solution is better over another. Below there is a summary table.

Table 1 - Foundation technologies by Water Depth and Turbine Size

		WATER DEPTH					
		10 m	20 m	30 m	40 m	50 m	60 m
TURBINE SIZE	4 MW	Monopile	Monopile	Monopile	Monopile / Other	Other	Other
	6 MW	Monopile	Monopile	Monopile / Other	Monopile / Other	Other	Other
	8 MW	Monopile	Monopile / Other	Other	Other	Other	Other
	10 MW	Monopile	Other	Other	Other	Other	Other

The New York Bight selected area is in the 40-50 m water depth range, hence a monopile solution won’t be the most effective.

Given the above, the project will make use of a jacket solution. Some key advantages of a jacket solution over a monopile are listed below:

- **Low deflections** – the jacket provides more stability (higher stiffness to weight ratio) as opposite to monopile in terms of deflection at the top of the tower;
- **Post installation remedial** – the jacket is a proven and consolidated technology, as opposite to monopile, as the latter has shown some issues with crumbling grout and scour deterioration;
- **Scour protection** – there is no need for large scour protection at the base of the foundation, as opposite to monopiles.

The Jacket is a typical 4 leg structure with the same slope on each side and with pile shoes at the bottom end of each leg to couple inside foundation piles. The legs at the top jacket edge will be welded to a tubular transition piece having the same tower bottom section diameter and flange for the connection.

Four piles driven on the seabed are used as foundation of the Jacket and to support the entire WTG assembly. The preliminary pile and jacket features are shown below.

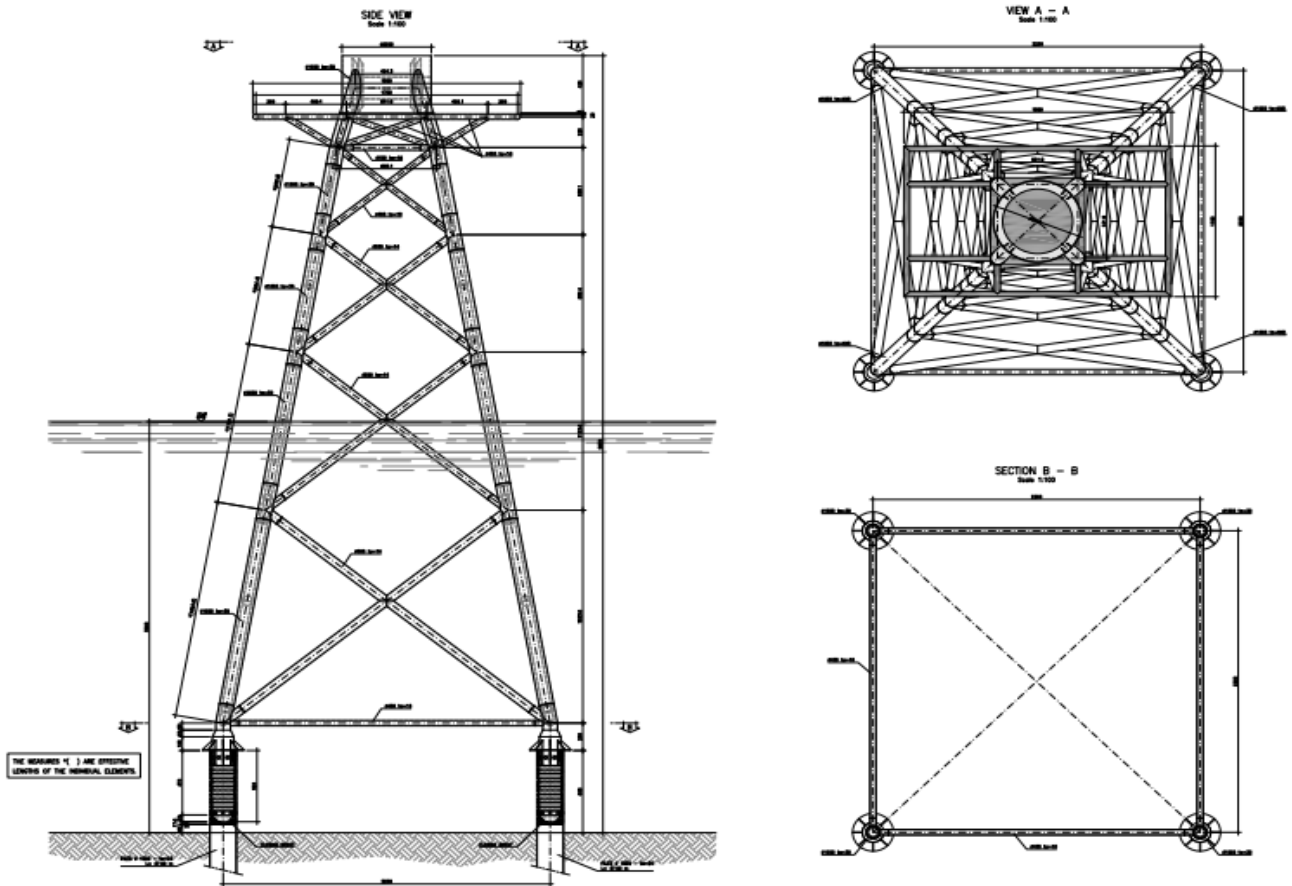

Figure 1 - Jacket design

## **DEVELOPMENT APPROACH**

At this stage, the soil conditions are unknown. A preliminary Geophysical and Geotechnical survey will be the first step for the definition of this information. In accordance with what has been done in Maryland, US Wind plans to collect a borehole at the met tower/buoy location, in order to kick-off the Engineering of the met tower foundation/buoy anchors for the Site Assessment Plan to be submitted to BOEM, plus a series of additional boreholes needed for the Preliminary Engineering of the WTG foundations. Between 10 and 15 boreholes will be collected during the preliminary G&G. A second and more detailed G&G will provide full coverage of the area for the Detailed Engineering.



# SUBMARINE CABLES



## PROJECT OVERVIEW

The overall 800 MW New York Wind Project will be divided into 2 major 400 MW projects NY Bight 1 and NY Bight 2 located in the NY York Bight BOEM leasing area. The wind turbine generators (WTG) will be connected through 34.5kV arrays and combined to be stepped up to 230kV. The 230kV collection system will be combined and converted into High Voltage Direct Current (HVDC) power at 2 offshore HVDC Voltage Source Converter (VSC) platforms for long distance transmission to the proposed Point of Interconnection (POI) at Con Edison’s Gowanus 345kV substation in Brooklyn, New York. The power will be injected into the NYISO network via the Gowanus 345kV ring bus. The onshore converter stations will be located as close as possible to the Gowanus substation and are proposed to be located at South Brooklyn Marine Terminal.

## ELECTRICAL COLLECTION SYSTEM

The proposed WTG electrical collection system will consist of multiconductor 35kV submarine cables connecting the WTG’s in series of 34.5kV nominal arrays. The 34.5 kV arrays will be connected to 35kV Gas Insulated Switchgear (GIS) circuit breakers assembled into a collector bus on an Offshore Transformer Module (OTM) platform. The 34.5kV GIS collector bus will be connected into a 34.5-230kV step up transformer at each OTM for 230kV transmission to a HVDC VSC converter platform. The initial design proposes a 150/200/250MVA ONAN/ONAF/ONAF transformer to be utilized at each OTM. NY Bight 1 and NY Bight 2 will each utilize two (2) OTM’s to transmit 200 MW per OTM to a offshore HVDC converted platform. A total of four (4) OTM’s and two (2) HVDC converter platforms will be installed throughout the two (2) 400 MW projects to realize the combined total 800 MW injected into the NYISO network at Gowanus Substation.

The number of WTGs per 34.5kV array and cable sizes used will be determined by the final WTG selected for the project and the layout of the WTG’s throughout the project lease area. The final WTG locations, cable route and foundation selection will require the lease area to be analyzed via a bathymetric survey and geological site investigation to determine the seabed topology and soil characteristics.

GIS switchgear will be utilized throughout the 34.5kV and 230kV networks as it provides several advantages over Air Insulated Switchgear (AIS) in offshore applications including:

- Grounded enclosure provides safer working environment;
- Highly Reliable due to compartmentalized enclosure of the live parts and insulation system;
- Reduced space requirement – Gas insulation allows significantly reduced electrical clearances, creating a more compact design;
- Low maintenance requirements – Gas insulated live parts proves a hermetically sealed design and minimal impact from the surrounding environment.

**Cross section drawing of TFRA 36 kV 3x1x150 mm<sup>2</sup> AQ + FO**

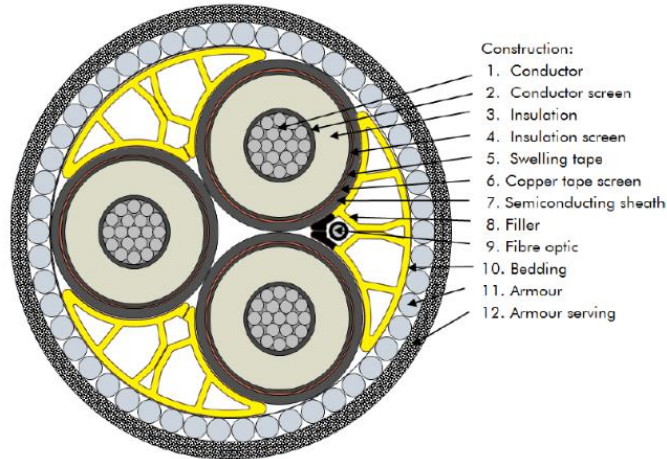
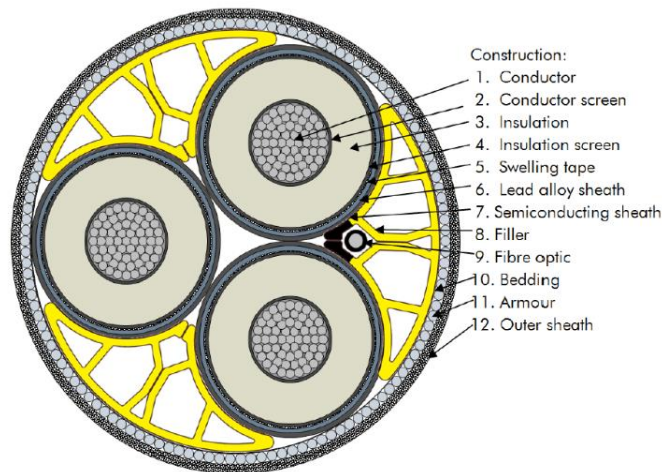

**Figure 1 - Inter-array cable cross section**

## EXPORT CABLE TRANSMISSION SYSTEM

The power generated by the WTG’s and collected by the 34.5kV and 230kV AC collection systems will be converted to +/- 320kV High Voltage Direct Current (HVDC) power at offshore converter station platforms for long distance transmission to shore converter station where it is converted back to HV AC. The AC power from the converter station will be stepped-up to 345kV for short AC transmission and interconnections at the Gowanus Substation. Each offshore converter stations (2 total) will send 400MW of generated power via a ±320kV bipole cable link utilizing two (2) single conductor 1000mm<sup>2</sup> Cu XLPE submarine cables to each shore converter station.

Routing of the cable is restricted as it leaves the Offshore Converter Platform by the inter-array cables. Crossing of the cable systems will be avoided, as it would limit burial depths and complicate future maintenance. The OTM location and inter-array cable systems will be designed to provide each project with a wind farm exit path for the export cable. As the cable transitions from the New York Upper Bay into the South Brooklyn Marine Terminal, it is anticipated that horizontal directional drilling (HDD) will be required to minimize the impact on the pier.



**Figure 2 - Export cable cross section**

## HVDC ADVANTAGES

HVDC transmission is ideal for this long-distance transmission systems as the electrical losses are significantly less than AC transmission due to transmitting only active power. HV AC transmission would not be viable at the transmission length and power transfer capability required for this project due to capacitive cable charging produced by reactive power transmitted with AC. HV AC cables are generally limited to 500 MW or less and cable lengths up to 130 km.

Unlike AC, the line losses for an HVDC solution are insignificant and represent the most efficient way to transmit power over long distances as shown the graph below.

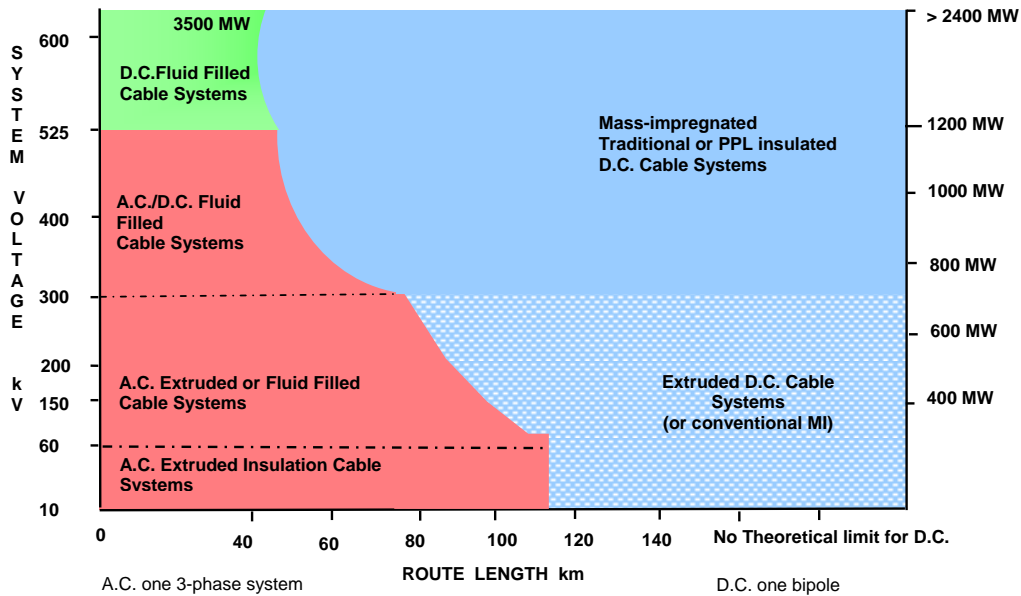

Figure 3 - AC & HVDC Transmission Cable Systems

The converter systems will be the latest proven HVDC technology utilizing Modular Multi Level (MML) Voltage Source Converter (VSC) type HVDC converters, which allows for significant space savings and enhanced electrical performance over conventional Line Commutated Converter (LCC) HVDC systems.

High Voltage Direct Current (HVDC) transmission is a consolidated and proven technology adopted in many high voltage transmission applications worldwide, including the Neptune Regional Transmission System and the Transbay links in US for moving bulk power.

More recently HVDC MML VSC technology has been introduced in the offshore wind market for power transmission of remote wind parks in Europe.

The main advantages given by a High Voltage Direct Current (HVDC) connection to the existing AC power grid are:

- Economical and efficient power transmission, with low transmission losses;
- Connection of asynchronous grids or grids with different frequencies;
- System isolation protects against blackouts in case of overloads;

- Black start capability;
- No short circuit contribution to the interconnected AC system;
- Increase of transmission capacity and system stability;
- Independent control of active and reactive power;
- AC voltage control.

HVDC VSC converters have been installed on multiple European offshore wind farms with similar power transmission capacities including:

- BorWin1 (400 MW, 200km, ABB);
- BorWin2 (800 MW, 200km, Siemens);
- BorWin3 (900 MW, 160km, Siemens);
- DolWin1 (800 MW, 165km, ABB);
- HelWin1 (576 MW, 130km, Siemens);
- HelWin2 (690 MW, 130km, Siemens);
- SylWin1 (864 MW, 205km, Siemens)

US based VSC HVDC transmission links:

- Transbay (400 MW, 85km, Siemens);
- Cross Sound-Link (330 MW, 40km, Siemens).

Based on the above considerations, US Wind proposes to adopt the HVDC solution, with a shore based HVDC converter station in close proximity to the Gowanus substation.

## CABLE MANUFACTURING

The insulation system consists of an inner semi-conducting screen layer, the insulation compound and an outer semi-conducting insulation screen, extruded simultaneously. The insulation is composed of a cross-linked polyethylene (XLPE) suitable for HVDC application.

A semi-conducting water swelling tape is then applied between the outer semi-conducting screen and the metallic sheath in order to limit water propagation along the cable core in case of cable damage.

The metallic sheath is made of lead alloy, over which it is extruded a layer of polyethylene compound.

The “armoring” includes bedding, armor and serving, applied in one common process.

Armor is made of one layer of galvanized steel wires. Serving is made of polypropylene strings that provide a degree of abrasion protection and reduce cable friction during laying.

## CABLE INSTALLATION

The area approaching New York is quite congested and a route will need to be found that takes into account the existing pipeline, cable and shipping channels.

The first crossing to consider would be the Verrazano Narrows Bridge which has a vertical height restriction of 55 meters and an established shipping channel passing under the center of the bridge. The installation vessels will pass under this bridge.

Cable installation in the shipping channel should be avoided due the risk of cable damage by dropped anchors and the increased cable burial depth requirements (5 meters). That leaves a 300m distance between the pier and the edge of the shipping channel and both sides to place 6 or 7 cables. We would assume a 50m separation between cables.

Passing north, there are several pipeline crossings which should not present a problem for the installation providing the owner agrees the crossing methodology. The water depth at around 50ft (18m) is acceptable for the installation vessel. There is an existing power cable approaching the Gowanus Sub via the northerly approach through Red Hook Channel so an approach via Bay Ridge channel would be preferred.

The proposed installation method is based on cable installation by mean of simultaneous lay and burial operation, considering a water depth ranging from 10m to 30m, a seabed substantially flat without steep slopes and composed by soft/unconsolidated sediments; in case of sections where simultaneous lay and burial may not be implemented, for example at crossing with in service utilities, different cable protection solutions can be proposed.

The cable installation will be executed in a certain number of campaigns since it will not be possible to load on board the vessel the entire cable quantity. The cable lengths that can be stored on the vessel will depend on the actual cable size, weight, installation methodology (cable bundle, single cable laying) and lay vessel cable storage capacity.

The typical cable lengths that can be installed in a single length are:

- HVAC three core cable – from 15 nm to 22 nm (30 km to 40 km);
- HVDC single core cables laid in bundle – from 22 nm to 27 nm (40 km to 50 km).

A certain number of joints shall be installed on site depending on the cable quantity that can be installed in one length.

## 66KV INTER-ARRAY RATING OPTION

Pending further investigations and system engineering studies, another feasible option could be to use a 66kV inter-array system. US Wind will evaluate this scenario in the Preliminary Engineering phase.



# LIKELY POWER PURCHASERS AND LIKELY PROCUREMENT APPROACH

## LIKELY POWER PURCHASERS

### NEW YORK

The nominated area is well positioned to serve primarily New York. On January 29, 2018, NYSERDA released the New York State Offshore Wind Master Plan (“**Master Plan**”), which presents a comprehensive roadmap to encourage the development of 2,400 MW of offshore wind by 2030. The Master Plan is supported by NYSERDA’s Offshore Wind Policy Options Paper (“**Options Paper**”), which was filed with the Commission for consideration. The Option Paper recommends two phases for offshore wind development:

- **Phase 1** – procurement of Offshore Wind Renewable Energy Credits (“**ORECs**”) associated with approximately 800 MW of offshore wind over an initial two-year period;
- **Phase 2** – remainder of offshore wind to be procured in future years as the domestic offshore wind industry matures and the resulting expected price declines materialize.

The above efforts were the results of the Clean Energy Standard (“**CES**”), adopted on August 1<sup>st</sup>, 2016 by the Public Service Commission with a designed statewide goal of 50% renewable generation resources by 2030.

With effective date July 12<sup>th</sup>, 2018, New York took another major step forward with **Case 18-E-0071** the “*Order Establishing Offshore Wind Standard and Framework for Phase 1 Procurement*”. With this case, the Public Service Commission determined a series of necessary actions related to offshore wind in order to achieve the CES goal and adopted a supplementary goal to contribute toward the overall objective of the CES, that is based on contributions towards achievement by each New York Load Serving Entity (LSE) serving retail customers, including the non-jurisdictional Long Island Power Authority (LIPA) and New York Power Authority (NYPA). In furtherance of this supplementary goal, the Commission adopted an Offshore Wind Standard including:

- Initial procurement solicitations, to be held by NYSERDA, NYPA and/or LIPA in 2018 and 2019, for ORECs associated with approximately 800 MW of offshore wind (i.e. Phase 1); and
- An obligation on LSEs to obtain, on behalf of their retail customers, the ORECs procured in Phase 1 in an amount proportional to their load.

### NEIGHBORING STATES

Given the strategic position of the proposed Call Areas, there is the possibility of serving other states as well, as each of the neighboring states has RPS requirements that ramp up over time.

## LIKELY POWER PROCUREMENT APPROACH

With respect to power procurement solicitation from New York State, six different procurement options were identified, four of which had been analyzed by NYSERDA in the Options Paper. The six options were:

- Fixed OREC;
- Market OREC;
- Index OREC;
- Forward OREC;
- Fixed/Index OREC;
- Capped OREC.



*US Wind, Inc. – Nomination for Commercial Leasing for Wind Power on the Outer Continental Shelf in New York Bight in Response to BOEM's Call for Information and Nominations*

With the Order 18-E-0071, the New York Public Service Commission adopted a hybrid procurement approach, requiring developers to provide two separate bids:

- Fixed OREC price;
- Adjustable OREC based on a bid Strike Price, using the Index OREC procurement method.

Should US Wind receive the area nominated in this application, US Wind will participate to the procurement process being prepared to commit to both a fixed price and/or an adjustable price regime, as determined by NYSERDA.

In case of other and different opportunities, including those outside the discussed procurement solicitation, US Wind will evaluate all the procurement options on a case by case basis.



# ASSESSMENT OF PORTS AND INFRASTRUCTURE

## INTRODUCTION

The selection of the areas to support the offshore wind activities is a critical step in the development process. The installation strategy, including routes, timings, number and typologies of assets to be used, as well as CapEx and OpEx figures, are all impacted by this decision.

New York shows a great potential in terms of areas suitable to support the offshore wind development. In the following sections, a number of solutions have been evaluated. One of the challenges to be faced is given by the air draft, restricted by some of the New York’s bridges located along the shipping channels. This will require some components to be transported horizontally, rather than vertically (typical solution in Europe). If we exclude the air draft restrictions, however, New York has many options available and suitable. In the following sections, there is a first analysis completed using public resources, knowledge of the area, European experience, and experience developed on the MarWin Project in Maryland.

## SUITABLE AREAS

There are various areas in New York that are suitable for manufacturing facilities. Although none of them are already fit to purpose, the level of investments required for the upgrading is compatible with a typical offshore wind development business plan. Example of potential suitable areas are:

- Red Hook Brook-Brooklyn;
- South Brooklyn Marine Terminal (SBMT);
- Military Ocean Terminal at Bayonne (MOTBY);
- Port of Albany-Rensselaer;
- Port of Coeymans.

With respect to staging and installation facilities, there are various potentially suitable areas as well:

- Red Hook Brook-Brooklyn;
- South Brooklyn Marine Terminal (SBMT);
- Military Ocean Terminal at Bayonne (MOTBY);
- Werner Power Station (decommissioned);
- Shoreham Nuclear Generating Station (inactive).

However, there are some challenges as well in using the above staging and pre-assembly areas for offshore wind. For both the inbound logistics (components shipped from other ports to onshore site) and the outbound logistics (components pre-assembled at onshore site and shipped to the offshore lease area) the air draft would be a problem, forcing the components to be moved vertically rather than horizontally. The installation strategy for the turbines is impacted as well, forcing an installation in multiple components rather than in a single pre-assembled solution.



**Figure 1 - WTGs transported in vertical position**

Indeed, Red Hook, SBMT, and MOBTY are impacted by the presence of the Verrazano Narrows Bridge. Overall, these three sites are probably still better than the other two (Werner Power Station and Shoreham Nuclear Generating Station), due to the significant investments required on these solutions.



**Figure 2 - Verrazano Narrows Bridge**

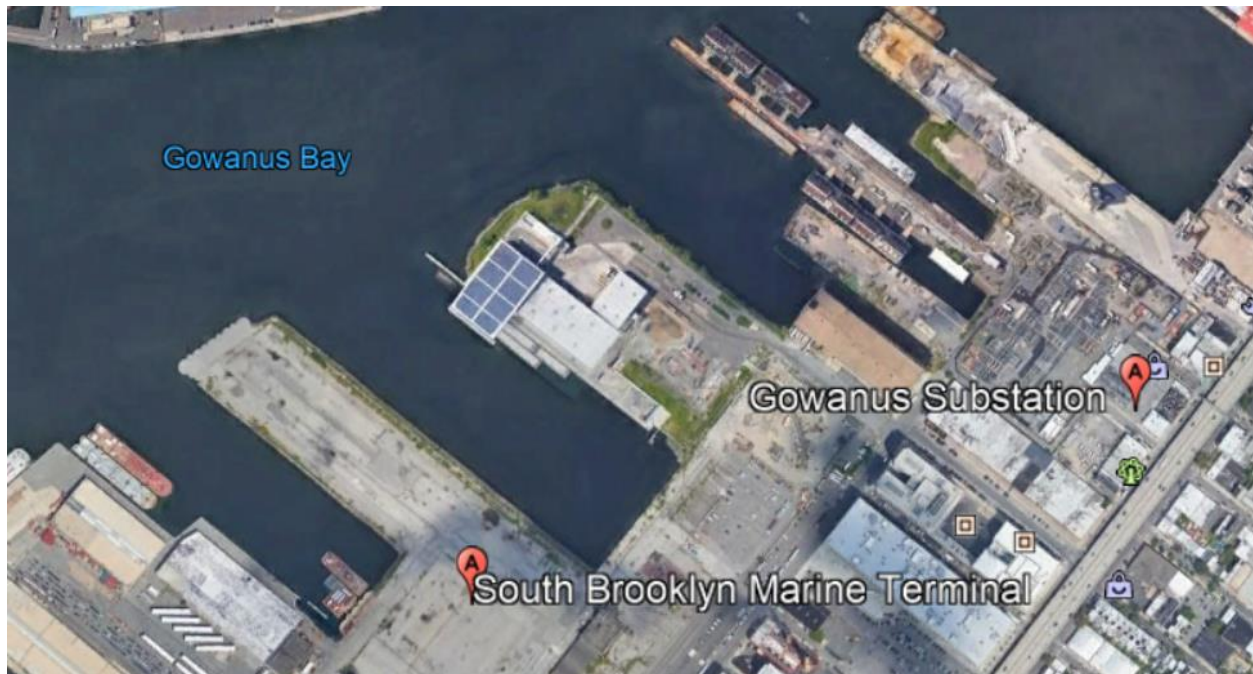

Figure 3 - The South Brooklyn Marine Terminal

## THE EXPERIENCE ON THE MARWIN PROJECT

US Wind developed extensive experience in more than 3 years of development on the Maryland Project (MarWin). US Wind received inputs from tier 1 market leaders and developed strategies to best approach the offshore wind industry here in the USA. The requirements for a large-scale wind farm are the following:

- Manufacturing and Fabrication facility = 25 acres;
- Staging and pre-assembly area = 25 acres;
- Operations and maintenance = 2-10 acres.

For the O&M, it largely depends on where the strategic spare parts will be stored (Operator's yard or O&M provider's).

## THE EUROPEAN EXPERIENCE

Europe is now heading towards the 15 GW of offshore wind energy and has various locations developed to suit the mature offshore wind industry. Some of these sites are:

- Bremerhaven, Germany – 440 acres;
- Cuxhaven, Germany – 645 acres;
- Esbjerg, Denmark – 864 acres;
- Eemshaven, Netherlands – 230 acres;
- Belfast Harbor – 100 acres.

Each of these sites has enough quayside/piers to support the required inbound and outbound logistics.

With respect to the bearing capacity, up to 20 metric tons/m<sup>2</sup> (4,000 psf) are envisaged, depending on the specific location (e.g. underneath the cranes).

They are also characterized by no air draft restrictions, minimum 20-25 ft. water depth, and good interconnections (usually, railways access).

## UPGRADES REQUIRED AT MANUFACTURING AND FABRICATION PORTS

As discussed in the previous section, each of the available options will require some sort of investment at the manufacturing and fabrication ports. The main upgrades are:

- **Pier/Wharf** – Most likely, any solution selected will require upgrades at the pier/wharf, in order to reach the up to 4,000 psf discussed;
- **Fender system** – The wharf/pier needs to be protected from impacts and abrasions from berthing vessels;
- **Bulkhead** – A bulkhead with HP anchor piles and cast-in-place concrete caps is likely needed, in order to provide stabilization to protect from erosion;
- **Paving of the area** – High-load-capacity reinforced concrete will be required at the storage location.

The upgrades will also depend on the size of the wind farm (800 MW in this case) and if multiple and parallel wind farm developments are to be taken into account.

Overall, between \$15 million and \$50 million is a likely range for the investments required.

## UPGRADES REQUIRED AT STAGING AND INSTALLATION PORTS

More or less the same upgrades and investments are likely needed for the staging and installation ports. Significant optimizations can be achieved if these activities are concentrated in the same area. With reference to the experience in Maryland, for example, the manufacturing and staging/pre-assembly activities are being planned in the pre-selected TradePoint Atlantic area.

## ASSIGNING A SCORE TO EACH SITE

Assigning a score to a site for the purpose of selecting the best suitable area for offshore wind port development is a difficult task. In the following sections, the best locations for the main selection criteria are listed. The selection criteria are the following:

- Investment / upgrade required;
- Approximate distance to the wind energy areas;
- Upland area;
- Water frontage;
- Wharf length;
- Navigable depth;
- Air draft restriction.



**BEST LOCATIONS FOR INVESTMENT / UPGRADE REQUIRED**

Each location available will require some investments, from minimal to significant. With this respect, the best locations are:

- **Military Ocean Terminal at Bayonne (MOTB) at New York Harbor, Upper Bay;**
- **Weeks Marine, Inc, at New York Harbor, Upper Bay;**
- **South Brooklyn Marine Terminal at New York Harbor, Upper Bay;**
- **Red Hook Brooklyn at New York Harbor, Upper Bay;**
- **Port of Coeymans Marine Terminal at Hudson River Waterways;**
- **Port of Albany-Rensselaer at Hudson River Waterway.**

Each of the areas above can serve as either manufacturing and fabrication area or staging area; or both.

**BEST LOCATIONS FOR APPROXIMATE DISTANCE TO NY AREAS**

With reference to the above locations, the approximate distances are listed below:

- **Military Ocean Terminal at Bayonne (MOTB) at New York Harbor, Upper Bay = 52.7 miles;**
- **Weeks Marine, Inc, at New York Harbor, Upper Bay = 54.3 miles;**
- **South Brooklyn Marine Terminal at New York Harbor, Upper Bay = 53.2 miles;**
- **Red Hook Brooklyn at New York Harbor, Upper Bay = 55.8 miles;**
- **Port of Coeymans Marine Terminal at Hudson River Waterways = 185.5 miles;**
- **Port of Albany-Rensselaer at Hudson River Waterway = 195.2 miles.**

The distance to the offshore site is an important factor to consider in terms of installation times and costs; with this respect, the first four sites are the best locations, whereas the Port of Coeymans Marine Terminal and the Port of Albany-Rensselaer are characterized by longer distances.

**BEST LOCATIONS FOR UPLAND AREAS**

Referring to the same locations investigated above, the upland areas available are the following:

- **Military Ocean Terminal at Bayonne (MOTB) at New York Harbor, Upper Bay = 52 acres;**
- **Weeks Marine, Inc, at New York Harbor, Upper Bay = 43 acres;**
- **South Brooklyn Marine Terminal at New York Harbor, Upper Bay = 88 acres;**
- **Red Hook Brooklyn at New York Harbor, Upper Bay = 80 acres;**
- **Port of Coeymans Marine Terminal at Hudson River Waterways = 400 acres;**
- **Port of Albany-Rensselaer at Hudson River Waterway = 266 acres.**

Each of the areas evaluated has sufficient space to accommodate at least a manufacturing site or a staging site. The Port of Coeymans Marine Terminal and the Port of Albany-Rensselaer score high in terms of space, whereas the Weeks Marine yard is less than 25 acres. Assuming 50 acres is needed for both manufacturing and staging and assuming we combine both the two scopes in a single area, the Weeks Marine site doesn’t pass this evaluation criteria.



## BEST LOCATIONS FOR WATER FRONTAGE

- **Military Ocean Terminal at Bayonne (MOTB) at New York Harbor, Upper Bay = 20,650 ft.;**
- **Weeks Marine, Inc, at New York Harbor, Upper Bay = 4,460 ft.;**
- **South Brooklyn Marine Terminal at New York Harbor, Upper Bay = 9,380 ft.;**
- **Red Hook Brooklyn at New York Harbor, Upper Bay = 16,000 ft.;**
- **Port of Coeymans Marine Terminal at Hudson River Waterways = 3,260 ft.;**
- **Port of Albany-Rensselaer at Hudson River Waterway = 7,870 ft.**

Each location has enough water frontage, with MOTB and Red Hook scoring highest.

## BEST LOCATIONS FOR WHARF LENGTH

Each location has some wharf length available. There is no list provided here as there are multiple piers available at certain sites. **Red Hook is the location with the highest score, given the 16,000 ft long wharf.**

## BEST LOCATIONS FOR NAVIGABLE DEPTH

With the current trend in Installation Vessels, 20 ft. is a minimum for the water depth. Taking into account tidal fluctuations and the latest design in IVs, 30-40 ft. is a better value.

The water depth requirement largely depends also on the installation strategy: a barge installation concept requires just 13 ft. for transporting the turbine components, whereas the latest generation of installation vessel could require 38 ft.

Hence, the assessment has to be divided in IV concept and barge concept, as per below.

- **IV concept**
  - o **Military Ocean Terminal at Bayonne (MOTB) at New York Harbor, Upper Bay = 48 ft. (berth);**
  - o **Weeks Marine, Inc, at New York Harbor, Upper Bay = 53 ft. (channel – berth w.d. N/A);**
  - o **South Brooklyn Marine Terminal at New York Harbor, Upper Bay = 0-36 ft. (berth – channel 53 ft.);**
  - o **Red Hook Brooklyn at New York Harbor, Upper Bay = 42 ft. (berth – channel = 38-42);**
  - o **Port of Coeymans Marine Terminal at Hudson River Waterways = 30 ft. (berth – channel = 32 ft.);**
  - o **Port of Albany-Rensselaer at Hudson River Waterway = 32 ft. (channel – berth w.d. N/A).**
- **Barge concept**
  - o **Military Ocean Terminal at Bayonne (MOTB) at New York Harbor, Upper Bay = 48 ft. (berth);**
  - o **Weeks Marine, Inc, at New York Harbor, Upper Bay = 53 ft. (channel – berth w.d. N/A);**

- **South Brooklyn Marine Terminal at New York Harbor, Upper Bay = 0-36 ft. (berth – channel 53 ft.);**
- **Red Hook Brooklyn at New York Harbor, Upper Bay = 42 ft. (berth – channel = 38-42);**
- **Port of Coeymans Marine Terminal at Hudson River Waterways = 30 ft. (berth – channel = 32 ft.);**
- **Port of Albany-Rensselaer at Hudson River Waterway = 32 ft. (channel – berth w.d. N/A).**

Hence, just three sites are suitable for a latest generation IV concept (MOTB, possibly Weeks Marine, and Red Hook), whereas all of them are suitable for a barge concept.

## BEST LOCATIONS FOR AIR DRAFT

The air draft requirement largely depends on what needs to be shipped (e.g. foundations or turbines) and in which manner (e.g. vertically or horizontally).

With respect to foundations, and limiting the selection to just monopiles and jackets, the requirements are:

- Monopile = 60 ft.;
- Jacket = 230 ft. for vertical transport (preferred) or 100 ft. for horizontal transport.

With respect to the turbines, the requirement is 400 ft. (for fully assembled components).

Due to the Verrazano-Narrows Bridge, having an air draft of 198 ft. at the center, no one of the first four locations are suitable for jackets transported in vertical position; they are, however, suitable for jackets in horizontal position or monopiles.

Even worse for the Port of Coeymans Marine Terminal and the Port of Albany-Rensselaer, as the air draft due to the Mid-Hudson Bridge is 134 ft.

There are no locations suitable for moving the turbines fully assembled.

Hence, assigning a higher score to the first four locations as they provide more flexibility with the 198 ft. restriction (as opposed to 134 ft.), the results are the following:

- **Military Ocean Terminal at Bayonne (MOTB) at New York Harbor, Upper Bay = 198 ft. (Verrazano-Narrows Bridge);**
- **Weeks Marine, Inc, at New York Harbor, Upper Bay = 198 ft. (Verrazano-Narrows Bridge);**
- **South Brooklyn Marine Terminal at New York Harbor, Upper Bay = 198 ft. (Verrazano-Narrows Bridge);**
- **Red Hook Brooklyn at New York Harbor, Upper Bay = 198 ft. (Verrazano-Narrows Bridge);**
- **Port of Coeymans Marine Terminal at Hudson River Waterways = 134 ft. (Mid-Hudson Bridge);**
- **Port of Albany-Rensselaer at Hudson River Waterway = 134 ft. (Mid-Hudson Bridge).**

## BEST LOCATIONS OVERALL

Considering all the evaluation criteria, the following two areas resulted in being the best options (pending further and more detailed analysis):

- **Military Ocean Terminal at Bayonne (MOTB) at New York Harbor, Upper Bay;**
- **Weeks Marine, Inc, at New York Harbor, Upper Bay;**
- **South Brooklyn Marine Terminal at New York Harbor, Upper Bay;**
- **Red Hook Brooklyn at New York Harbor, Upper Bay;**
- **Port of Coeymans Marine Terminal at Hudson River Waterways;**
- **Port of Albany-Rensselaer at Hudson River Waterway.**

South Brooklyn Marine Terminal could be suitable as well, depending on further analysis on the water depth.



# BENEFITS AND COST- REDUCTIONS FROM OFFSHORE WIND

## INTRODUCTION

In common with other clean sources, offshore wind power can help to build a diversified and geographically distributed U.S. energy mix, offering protection against many potential energy supply emergencies, whether natural or man-made. The United States have an enormous potential in offshore wind energy resources, estimated in four times the nation’s present electricity capacity.

There are multiple benefits coming from offshore wind development. Offshore wind brings:

- **Clean, locally produced power** – with wind abounding off the coasts of 26 states, there are suitable wind resources near large urban areas, where power demand is continuously growing, electricity prices are high, and the space available for new land-based generation and transmission facilities is limited;
- **Investments in infrastructure and communities** – offshore wind brings investments, as the ports and infrastructure need to be upgraded to support the development and installation of the generation and transmission facilities. Additional benefits come from locating new fabrication and manufacturing plants, to support the developing technologies used in offshore wind, such as XL monopiles, larger jackets, suction bucket foundations, and gravity-based solutions;
- **Opportunity for thousands of skilled construction, manufacturing, and operation jobs** – offshore wind brings hundreds of billions in new economic activity and the creation of thousands of well paid jobs in engineering, manufacturing, construction, operations and maintenance. The National Renewable Energy Laboratory (“NREL”) estimated that offshore wind will create more than 20 direct jobs for every megawatt produced in the United States.

To better address each of these benefits, US Wind defined the following three major categories:

- Environmental benefits;
- Electricity system benefits;
- Socioeconomic benefits.

In the following sections, the above benefits are discussed separately.

## ENVIRONMENTAL BENEFITS

With very low carbon dioxide emissions and negligible emissions of mercury, nitrous oxides, and sulfur oxides compared to conventional electrical power generation, offshore wind power has enormous environmental benefits.

Moreover, there is no production of solid or liquid wastes associated with the electricity generation, as opposite to coal, oil, natural gas, biomass, or nuclear power.

Below there is a summery of some of the potential environmental benefits coming from offshore wind.

- **Health**
  - o Reduction or elimination of greenhouse gas emissions;
  - o Reduction or elimination of criteria pollutant emissions;
  - o No smog;
  - o No particulate emissions;
  - o No fly ash or bottom ash (coal-fired plants);

- No spent fuel rods (nuclear);
- Operational noise away from residences and population centers;
- Construction noise away from residences and population centers;
- **Fishing**
  - Recreational fisheries increase due to greater or more concentrated fish resources;
  - Benefit to fisheries that use gear that would be especially well-suited for operation within a wind farm;
- **Recreation and Tourism**
  - Tourism attracted by offshore wind farms (clean energy and the beauty of technology);
- **Cultural resources**
  - By means of geological and geotechnical surveys, identification of previously unknown submerged cultural resources;
- **Water usage**
  - There are over 500 power plants in the U.S. that use waters for cooling purposes, removing and killing billions of aquatic organisms.

In terms of waste, for example, a typical coal plant includes more than 125,000 short tons of bottom ash and 193,000 short tons of fly ash from the smokestack scrubber each year. Nationally, at least 42 percent of coal combustion waste ponds and landfills are unlined according to the Union of Concerned Scientists.

Similarly, a nuclear power plant produces approximately 30 short tons of used fuel per year, creating tough challenges in disposal because, even after thousands of years, the spent fuel is still radioactive. A nuclear power plant also makes use of a large amount of water, with significant impacts on the environment.

The water usage is a major concern for New York, as the steam electric generating power plants in the state use up to 17 billion gallons of water per day, leading to entrapment, impingement, and death of fish.

If the State will succeed in the ambitious plan of 2,400 MW by 2030, the greenhouse gas emissions in New York will be reduced by more than five million short tons, equivalent to removing nearly one million cars from the road by 2030, also equivalent to \$1.9 billion (NPV) benefit based on the “social cost of carbon”.

The development of 2,400 MW of offshore wind energy would also avoid 1,800 tons of nitrogen oxides (NO<sub>x</sub>), 780 tons of sulfur dioxide (SO<sub>2</sub>), and 180 tons of PM<sub>2.5</sub>, equivalent to 18 fewer premature deaths annually.

Overall, the total annual health benefits of having 2,400 MW by 2030 is valued between \$73 million and \$165 million.

Additional information on the health benefits were estimated during the Offshore Renewable Energy Credit (OREC) procedures in Maryland; indeed, the Levitan’s report independently estimated an average annual change in annual air emissions of:

- CO<sub>2</sub> = 12,809 tons/year for US Wind and 6,384 tons/year for Skipjack;
- NO<sub>x</sub> = 6.8 tons/year for US Wind and 3.4 tons/year for Skipjack;
- SO<sub>2</sub> = 3.1 tons/year for US Wind and 1.6 tons/year for Skipjack.

## ELECTRICITY SYSTEM BENEFITS

The benefits in terms of electricity systems can be evaluated in terms of:

- Generation benefits;
- Transmission benefits.

New York has the following generators and facilities:

Fuel source	Generators	Facilities	Nameplate (MW)
Coal	18	7	2,634
Hydroelectric	392	160	4,672
Natural Gas	293	90	22,436
Nuclear	6	5	5,708

It is evident how there is very high dependency on natural gas. There is no diversification and being dependent on a specific source means being vulnerable to market fluctuations and source availability.

Additionally, the planned decommissioning of conventional power generation facilities must be considered, with coal and petroleum generations being retired in great extent in 2019. Offshore wind has the potential to displace aging power plants.

With respect to the transmission, power is moved from generator to load center through long distances between states and regions. One of the problems impacting transmission is given by the need for adequate capacity to supply power where it is needed, as often times there are bottlenecks creating congestion that could decrease the reliability and restrict competition, resulting in increased prices to consumers.

Transmission constraints are a major issue for New York. Although there are sources of low-cost onshore wind generation, the power is moved from remote areas to the major load centers, but such shipment happens during off-peak hours, rather than on-peak hours, as they exceed the capability of existing transmission facilities. Offshore wind can solve this problem. Approximately 50% of the U.S. population lives within 50 miles of a coast; this number goes up to 80% if we consider 200 miles. The population density of coastal shoreline counties is over six times higher than inland counties. Onshore wind resources, instead, are localized in the middle of the country, far away from large urban centers.

**By locating the generating facility close to the load center, there is no need for transmission moving power from remote areas or from long distances outside the state. This will result in decreased congestion, hence increased reliability, increased competition, and reduced prices to consumers.**

The daily production peaks are also an important aspect to take into account. Along the East coast, the offshore wind speeds are higher in the afternoon and evening hours. Instead, inland winds peak during the overnight hours and are relatively low in the afternoon. Hence, the offshore wind pattern is closer to the electricity demand.

## SOCIOECONOMIC BENEFITS

Socioeconomic benefits are benefits offered to a community as a whole and include long term impacts on the prevailing economic conditions. Certain impacts are prevalent during the construction phase of the project and may no longer occur when the project enters the operational phase. Certain other impacts are prevalent throughout the operational phase of the wind farm (20-25 years). Typical economic impacts are given by increase in occupation. Examples of potential jobs created by an offshore wind project are:

*US Wind, Inc. – Nomination for Commercial Leasing for Wind Power on the Outer Continental Shelf in New York Bright in Response to BOEM’s Call for Information and Nominations*

- Direct impacts – direct jobs involved in the construction, operation, and maintenance;
- Indirect impact – turbine manufacturing jobs, steel mill jobs, and parts manufacturers;
- Induced jobs – jobs at retail establishments, restaurants, childcare facilities, and hotels.

In the document “*The Workforce Opportunity of Offshore Wind in New York*” prepared by BVG Associates for NYSEERDA, BVG estimated:

- Up to 350 workers in project management and development;
- Up to 470 workers in installation and commissioning;
- Up to 2,250 workers in manufacturing;
- Up to 1,830 workers in O&M.

The ambitious plan set by New York has the potential to attract tier 1 global companies in relocating locally and opening new manufacturing facilities. If steel foundation fabrication is an activity already contemplated by other states, at the present time there are no plans for locating the production of elements such as blades and nacelles. New York has an opportunity to engage with tier 1 and tier 2 manufacturers to attract new facilities and expand the technical capabilities of existing infrastructure.

The three major wind turbine manufacturers – Siemens-Gamesa (SGRE), General Electric (GE), and Vestas – have only land-based wind nacelle assembly in the U.S. and most facilities are located in the Midwest. With New York’s ambitious plans for offshore wind, there is the potential for a local production of these components in-State, although not in the short period. As the Wind Turbine Generators are the main cost category in the CapEx, the resulting local content can be huge.

Blades can be locally manufactured as well. And because the size is becoming bigger and bigger, a local manufacturing facility in a coastal location becomes essential, given the transportation limitations due to the length of the component. There are domestic companies with experience in blade manufacturing, such as TPI Composites, that owns a facility in Fall River, Massachusetts. There are potential local companies as well, such as Derektor Shipyards and Scarano Ship Building but they would have to transition from boat building to blade manufacturing. Anyway, with an ambitious goal, the appetite for these companies could be high and a cost-benefit analysis could potentially take into account local production.

US Wind conducted a Jobs and Economic Development Impact (“**JEDI**”) analysis for the evaluation of the impacts coming from the proposed 800 MW generation facility. This tool has been developed by the National Renewable Energy Laboratory (“**NREL**”) and is an input-output spreadsheet-based model. JEDI uses state-specific multipliers for employment, earnings, and output (economic activity) from IMPLAN.

Further information on this analysis is included in the document “*JEDI Model Cost-Benefit Analysis*”.



STATEMENT THAT THE  
PROPOSED ACTIVITIES  
CONFORM WITH STATE AND  
LOCAL ENERGY PLANNING  
REQUIREMENTS,  
INITIATIVES OR GUIDANCE

**STATEMENT THAT THE PROPOSED ACTIVITIES CONFORM WITH STATE AND LOCAL ENERGY PLANNING REQUIREMENTS, INITIATIVES OR GUIDANCE.**

US Wind hereby confirms, to the extent permitted by the applicable laws, that all planned activities will conform to New York’s state and local energy planning requirements, initiative or guidance. Additionally, US Wind confirms that all planned activities will conform to all applicable federal, state and local laws and regulations.

Furthermore, the project contemplated by US Wind is fully consistent with and would help advance New York State’s key energy planning policies outlined in this response to nomination. The development of 800 MW of new offshore wind energy capacity will help the state address the capacity deficit and the need to increase domestic generation to meet increasing demand for electricity.

**NEW YORK STATE OFFSHORE WIND PROCUREMENT**

US Wind’s proposed project has been designed to specifically comply with New York State’s energy planning goals and policies. The document Case 18-E-0071 “*In the Matter of Offshore Wind Energy*” issued on July 12, 2018 by the State of New York Public Service Commission outlines the eligibility and the conditions that will be required for the development of an offshore wind farm.

In the next sections, the compliance of the project with the above-mentioned Order is discussed in detail.

**ELIGIBILITY**

After receiving comments from various stakeholders, the Commission defined the criteria for eligibility:

*Upon consideration, the Commission finds that eligibility should be limited to offshore wind electric generation facilities, located in ocean waters of the United States, that become operational on or after January 1, 2015, deliver their electric energy into the New York Control Area, either by direct lead into New York or directly into an adjacent control area with transmission into the New York Control Area, and that have obtained a lease from BOEM. Regarding other eligibility requirements, except to the extent requirements are specifically addressed in this Order, NYSERDA will have discretion to fashion eligibility requirements that carry out the intentions of this Order.*

Timing is of essence here: should US Wind receive an award for an offshore wind energy area as nominated in this response for nomination, the award could potentially arrive only after the Phase 1 Procurement Process. However, the timing of such award could potentially allow for bidding 800 MW on Phase 2 of the process.



CERTIFIED COPY OF  
ARTICLES

THE COMMONWEALTH OF MASSACHUSETTS

I hereby certify that, upon examination of this document, duly submitted to me, it appears that the provisions of the General Laws relative to corporations have been complied with, and I hereby approve said articles; and the filing fee having been paid, said articles are

deemed to have been filed with me on:

February 23, 2011 02:19 PM



WILLIAM FRANCIS GALVIN

*Secretary of the Commonwealth*

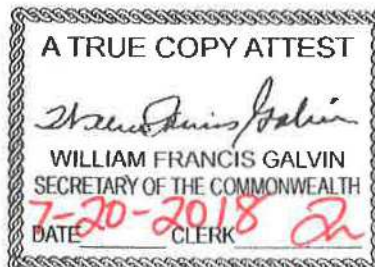

**CERTIFICATE OF CONVERSION  
OF A MASSACHUSETTS LIMITED LIABILITY COMPANY**

**(Under Chapter 156C Massachusetts General Laws)**

To the Secretary of the Commonwealth  
Commonwealth of Massachusetts

Federal Employer Identification Number: Applied For

It is hereby certified that:

1. The name of the limited liability company (the "Company") is:

US Wind LLC

2. The date of filing of the Company's certificate of organization:

The Company was organized in Massachusetts on February 11, 2011

3. The Company is converting to US Wind Inc.
4. The effective date of the conversion will be the date of filing the certificate of conversion.

[Remainder of page intentionally left blank]

This Certificate of Conversion is executed as an instrument under seal as of the 22<sup>nd</sup> day of February, 2011.

  
Name: Lawrence A. Eiben  
Title: Authorized Person

**D  
PC**

**The Commonwealth of Massachusetts**

**William Francis Galvin**  
Secretary of the Commonwealth  
One Ashburton Place, Boston, Massachusetts 02108-1512

FORM MUST BE TYPED

**Articles of Entity Conversion of a  
Domestic Other Entity  
to a Domestic Business Corporation**  
(General Laws Chapter 156D, Section 9.53; 950 CMR 113.30)

FORM MUST BE TYPED

(1) Exact name of other entity: US Wind LLC

(2) A corporate name that satisfies the requirements of G.L. Chapter 156D, Section 4.01:

US Wind Inc.

(3) The plan of entity conversion was duly approved in accordance with the organic law of the other entity.

(4) The following information is required to be included in the articles of organization pursuant to G.L. Chapter 156D, Section 2.02(a) or permitted to be included in the articles pursuant to G.L. Chapter 156D, Section 2.02(b):

**ARTICLE I**

The exact name of the corporation upon conversion is:

US Wind Inc.

**ARTICLE II**

Unless the articles of organization otherwise provide, all corporations formed pursuant to G.L. Chapter 156D have the purpose of engaging in any lawful business. Please specify if you want a more limited purpose:

Not Applicable

\* Professional corporations governed by G.L. Chapter 156A must specify the professional activities of the corporation.

**ARTICLE III**

State the total number of shares and par value, \* if any, of each class of stock that the corporation is authorized to issue. All corporations must authorize stock. If only one class or series is authorized, it is not necessary to specify any particular designation.

WITHOUT PAR VALUE		WITH PAR VALUE		
TYPE	NUMBER OF SHARES	TYPE	NUMBER OF SHARES	PAR VALUE
		Common	275,000	\$0.001

**ARTICLE IV**

Prior to the issuance of shares of any class or series, the articles of organization must set forth the preferences, limitations and relative rights of that class or series. The articles may also limit the type or specify the minimum amount of consideration for which shares of any class or series may be issued. Please set forth the preferences, limitations and relative rights of each class or series and, if desired, the required type and minimum amount of consideration to be received.

Not Applicable

**ARTICLE V**

The restrictions, if any, imposed by the articles of organization upon the transfer of shares of any class or series of stock are:

Not Applicable

**ARTICLE VI**

Other lawful provisions, and if there are no such provisions, this article may be left blank.

See attached Continuation Sheet VI-A

*Note: The preceding six (6) articles are considered to be permanent and may be changed only by filing appropriate articles of amendment.*

*\*G.L. Chapter 156D eliminates the concept of par value, however a corporation may specify par value in Article III. See G.L. Chapter 156D, Section 6.21, and the comments relative thereto.*



**ARTICLE VI**  
**CONTINUATION SHEET**

Other lawful provisions:

**Section 6.1 Annual Meetings.**

The annual meeting of the shareholders for the election of Directors and the transaction of such other business as may properly come before the meeting, whether or not specified in the notice of such meeting, shall be held after the close of the Corporation's fiscal year on such date and at such time as shall be designated by the Board of Directors.

**Section 6.2 Place of Meetings.**

Meetings of the shareholders shall be held at such place within or without the Commonwealth of Massachusetts as shall be designated by the Board of Directors or the person or persons calling the meeting. The Board of Directors may, in its sole discretion, determine that the meeting shall not be held at any place, but may instead be held solely by means of remote communication as provided under Section 7.08 of the Massachusetts Business Corporation Act.

**Section 6.3 Minimum Number of Directors.**

The Board of Directors may consist of one or more individuals, notwithstanding the number of shareholders; provided, however, that the Board of Directors shall have the authority to increase or decrease the number of the Directors of the Corporation (but not to fewer than the number of Directors then in office).

**Section 6.4. Quorum of Directors.**

A quorum of the Board of Directors shall consist of no fewer than one-third of the fixed or prescribed number of directors set forth in Section 6.3.

**Section 6.5. Authorization of Directors to Make, Amend or Repeal Bylaws.**

Except as otherwise provided in the Massachusetts Business Corporation Act, these Articles, or the Bylaws of the Corporation, the Board of Directors is expressly authorized and empowered to make, alter and repeal the Bylaws of the Corporation at any regular or special meeting of the Board of Directors duly convened after notice of that purpose, subject to the power of the shareholders of the Corporation to alter or repeal any Bylaw made by the Board of Directors; provided that not later than the time of giving notice of the meeting of shareholders next following the making, amending or repealing by the Board of Directors of any Bylaw, notice stating the substance of the action taken by the Board of Directors shall be given to all shareholders entitled to vote on amending the Bylaws.

**Section 6.6. Shareholder vote required to approve matters acted on by shareholders.**

The affirmative vote of a majority of all the shares in a voting group eligible to vote on a matter shall be sufficient for the approval of the matter, notwithstanding any greater vote on the matter otherwise required by any provision of Chapter 156D of the General Laws of Massachusetts.

**Section 6.7. Shareholder Action Without a Meeting by Less Than Unanimous Consent.**

Action required or permitted by Chapter 156D of the General Laws of Massachusetts to be taken at a shareholders' meeting may be taken without a meeting by shareholders having not less than the minimum number of votes necessary to take the action at a meeting at which all shareholders entitled to vote on the action are present and voting.

**Section 6.8 Shareholder quorum requirements.**

The initial bylaws or any bylaw subsequently adopted by the shareholders may alter the quorum requirement for any shareholder action.

**Section 6.9 Personal Liability of Directors to the Corporation.**

- (a) No Director of this Corporation shall be personally liable to the Corporation or its shareholders for monetary damages for breach of fiduciary duty as a Director notwithstanding any provision of law imposing such liability; provided, however, that this Section 6.9 shall not eliminate or limit any liability of a Director (i) for any breach of the Director's duty of loyalty to the Corporation or its shareholders, (ii) for acts or omissions not in good faith or which involve intentional misconduct or a knowing violation of law, (iii) for improper distributions under Section 6.40 of the Massachusetts Business Corporation Act, or (iv) with respect to any transaction from which the Director derived an improper personal benefit.
- (b) If Massachusetts law is hereafter amended to authorize the further limitation of the legal liability of the Directors of this Corporation, the liability of the Directors shall then be deemed to be limited to the fullest extent then permitted by Massachusetts law as so amended. Any repeal or modification of this paragraph of this Section 6.9 which may hereafter be affected by the shareholders of this Corporation shall be prospective only, and shall not adversely affect any limitation on the liability of a Director for acts or omissions prior to such repeal or modification.

**Section 6.10. Indemnification.**

This Corporation shall, to the fullest extent permitted by Massachusetts law as in effect from time to time, indemnify any person against all liability and expense (including attorney's fees) incurred by reason of the fact that he or she is or was a Director or officer of this Corporation, or while serving as a Director or officer of this Corporation, he or she is or was serving at the request of this Corporation as a director, manager, officer, partner or trustee of, or in any similar managerial or fiduciary position of, or an employee or agent of, another corporation, partnership, limited liability company, joint venture, trust, association or other entity. Expenses (including attorney's fees) incurred in defending an action, suit or proceeding may be paid by this Corporation in advance of the final disposition of such action, suit or proceeding to the full extent and under the circumstances permitted by the Massachusetts Business Corporation Act. This Corporation may purchase and maintain insurance on behalf of any person who is or was a Director, officer, employee, fiduciary, or agent of this Corporation against any liability asserted against and incurred by such person in any such capacity or arising out of such person's position, whether or not this Corporation would have the power to indemnify against such liability under the provisions of these Articles of Organization. The indemnification provided herein shall not be deemed exclusive of any other rights to which those indemnified may be entitled under these Articles, any Bylaw, agreement, vote of shareholders or

disinterested Directors, statute, or otherwise, and shall inure to the benefit of their heirs, executors, and administrators. The provisions of this Section 6.10 shall not be deemed to preclude this Corporation from indemnifying other persons from similar or other expenses and liabilities as the Board of Directors or the shareholders may determine in a specific instance or by resolution of general application.

**ARTICLE VII**

The effective date of organization of the corporation is the date and time the articles were received for filing if the articles are not rejected within the time prescribed by law. If a later effective date is desired, specify such date, which may not be later than the 90th day after the articles are received for filing.

**ARTICLE VIII**

The information contained in this article is not a permanent part of the articles of organization.

- a. The street address of the initial registered office of the corporation in the commonwealth:  
155 Federal St., Ste. 700, Boston, MA 02110
- b. The name of its initial registered agent or its registered office:  
CT Corporation System
- c. The names and addresses of the individuals who will serve as the initial directors, president, treasurer and secretary of the corporation (an address need not be specified if the business address of the officer or director is the same as the principal office location):

President: Alfonso Toto

Treasurer: Pierluigi Macchia

Secretary: Pierluigi Macchia

Director(s): Alfonso Toto

*If a professional corporation, include a list of shareholders with residential addresses and attach certificates of the appropriate regulatory board.*

- d. The fiscal year end of the corporation:  
December 31
- e. A brief description of the type of business in which the corporation intends to engage:  
Planning, development, construction, financing and management of renewable energy farms.
- f. The exact address of the principal office of the corporation:  
c/o K&L Gates LLP, One Lincoln St., Boston, MA 0211
- g. The street address where the records of the corporation required to be kept in the commonwealth are located in:

c/o K&L Gates LLP, One Lincoln St., Boston, MA 0211, which is  
*(number, street, city or town, state, zip code)*

- in principal office;
- an office of its transfer agent;
- an office of its secretary/assistant secretary;
- its registered office.

Signed by: \_\_\_\_\_

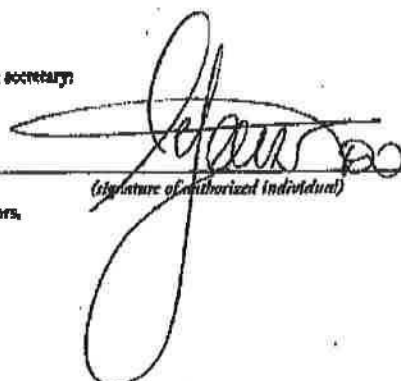

*(signature of authorized individual)*

- Chairman of the board of directors,
- President,
- Other officer,
- Court-appointed fiduciary.

on this 22<sup>nd</sup> day of February, 2011



# CERTIFICATE OF SECRETARY

**US WIND INC.**

**CERTIFICATE OF SECRETARY**

I, Salvatore Vitale, Secretary of US Wind Inc., a Massachusetts corporation (the “**Corporation**”), do hereby certify that the Corporation is incorporated and authorized to conduct business under the laws of the Commonwealth of Massachusetts and that it is authorized to hold leases, right-of-way grants, or right-of-use and easement grants for activities that produce, or support production, transportation, or transmission of, energy from sources other than oil and gas, on the Outer Continental Shelf (“**OCS**”), and right-of-use and easement grants for alternate use of OCS facilities for energy or marine-related purposes.

IN WITNESS WHEREOF, I have hereunto set my hand and affixed the seal of said Corporation, this 25<sup>th</sup> day of July, 2018.

\_\_\_\_\_  
Salvatore Vitale, Secretary



\_\_\_\_\_  
Affix CORPORATE SEAL



EVIDENCE OF AUTHORITY OF  
TITLED POSITIONS TO BIND  
CORPORATION, CERTIFIED  
BY SECRETARY/ASSISTANT  
SECRETARY OVER  
CORPORATE SEAL

**INCUMBENCY CERTIFICATE**

**OF**

**US WIND INC.**

The undersigned, Salvatore Vitale, Secretary of US Wind Inc., a Massachusetts Corporation (the "**Corporation**"), does hereby certify that the following named persons are presently serving the Corporation in the capacities set opposite their respective names:

<u>NAME</u>	<u>TITLE</u>
Riccardo Toto	President
Riccardo Toto	Treasurer
Riccardo Toto	Sole Director
Salvatore Vitale	Secretary

IN WITNESS WHEREOF, I have hereunto set my hand and affixed the seal of said Corporation, this 25<sup>th</sup> day of July, 2018.

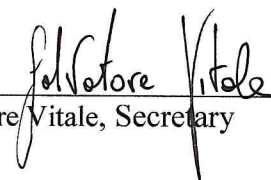
  
\_\_\_\_\_  
Salvatore Vitale, Secretary

Affix CORPORATE SEAL





**US WIND INC.**

**CERTIFICATE OF SECRETARY**

I, Salvatore Vitale, do hereby certify that I am the Secretary of US Wind Inc., a Massachusetts Corporation (the “**Corporation**”), and hereby further certify that the following is a true and correct copy of a resolutions duly adopted by the sole director of the Corporation on July 25<sup>th</sup>, 2018, and that said resolutions have not been amended or rescinded and at this date is in full force and effect:

WHEREAS, the Corporation wishes to acquire, hold and operate certain leases, right-of-way grants, or right-of-use and easement grants for activities that produce, or support production, transportation, or transmission of, energy from sources other than oil and gas, on the Outer Continental Shelf (“**OCS**”), and right-of-use and easement grants for the alternate use of OCS facilities for energy or marine-related purposes (collectively, the “**OCS Documents**”) and the Sole Director deems it advisable and in the best interest of the Corporation for the Corporation to enter into OCS Documents, as needed; and it is hereby

RESOLVED: That the OCS Documents, in the form presented to the Sole Director, are hereby approved, authorized and accepted; and it is

FURTHER RESOLVED: That Riccardo Toto, in his capacity as the President, Treasurer or sole director of the Corporation, and Salvatore Vitale, in his capacity as the Secretary of the Corporation (each, an “**Authorized Officer**” and collectively, the “**Authorized Officers**”), are each hereby individually empowered on behalf of the Corporation, in any matter related to the acquisition and operation of leases, right-of-way grants, or right-of-use and easement grants for activities that produce, or support production, transportation, or transmission of, energy from sources other than oil and gas, on the OCS, and right-of-use and easement grants for the alternate use of OCS facilities for energy or marine-related purposes, to agree upon the terms of and to execute and deliver any instrument or agreement, including any application, bid, lease, plan, right-of-way grant, right-of-use and easement grant, bond or other financial assurance instrument, assignment, designation of operator, relinquishment, amendment,

abandonment, power of attorney (including the revocation thereof), and any other paper contemplated by or in connection with the OCS Documents; and it is

FURTHER RESOLVED: That each of the Authorized Officers are hereby authorized to execute any power of attorney required in connection with the OCS Documents; and it is

FURTHER RESOLVED: That all instruments and documents previously executed and delivered by an Authorized Officer and all actions previously undertaken by them for and on behalf of the Corporation in connection with the transactions contemplated by the OCS Documents and these resolutions, are hereby approved, ratified, confirmed and adopted in all respects; and it is

FURTHER RESOLVED: That the Authorized Officers are hereby authorized and directed to pay all costs and expenses incurred by the Corporation in connection with the transactions contemplated hereby and thereby.

IN WITNESS WHEREOF, I have hereunto set my hand and affixed the seal of the Company, this 25<sup>th</sup> day of July, 2018.

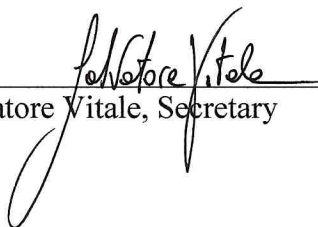
  
\_\_\_\_\_  
Salvatore Vitale, Secretary

Affix CORPORATE SEAL



US WIND INC.

**WRITTEN CONSENT OF SOLE DIRECTOR  
IN LIEU OF SPECIAL MEETING**

July ~~25~~<sup>11</sup>, 2018

The undersigned, being the sole director (the “**Sole Director**”) of US Wind Inc., a Massachusetts corporation (the “**Corporation**”), pursuant to the provisions of Section 8.21 of the Massachusetts Business Corporation Act, consent to the adoption of the following resolutions in lieu of holding a special meeting of the Board of the Corporation:

WHEREAS, the Corporation wishes to acquire, hold and operate certain leases, right-of-way grants, or right-of-use and easement grants for activities that produce, or support production, transportation, or transmission of, energy from sources other than oil and gas, on the Outer Continental Shelf (“**OCS**”), and right-of-use and easement grants for the alternate use of OCS facilities for energy or marine-related purposes (collectively, the “**OCS Documents**”) and the Sole Director deems it advisable and in the best interest of the Corporation for the Corporation to enter into OCS Documents, as needed; and it is hereby

RESOLVED: That the OCS Documents, in the form presented to the Sole Director, are hereby approved, authorized and accepted; and it is

FURTHER RESOLVED: That Riccardo Toto, in his capacity as the President, Treasurer or sole director of the Corporation, and Salvatore Vitale, in his capacity as the Secretary of the Corporation (each, an “**Authorized Officer**” and collectively, the “**Authorized Officers**”), are each hereby individually empowered on behalf of the Corporation, in any matter related to the acquisition and operation of leases, right-of-way grants, or right-of-use and easement grants for activities that produce, or support production, transportation, or transmission of, energy from sources other than oil and gas, on the OCS, and right-of-use and easement grants for the alternate use of OCS facilities for energy or marine-related purposes, to agree upon the terms of and to execute and deliver any instrument or agreement, including any application, bid, lease, plan, right-of-way grant, right-of-use and easement grant, bond or other financial assurance instrument, assignment, designation of operator, relinquishment, amendment,

abandonment, power of attorney (including the revocation thereof), and any other paper contemplated by or in connection with the OCS Documents; and it is

FURTHER RESOLVED: That each of the Authorized Officers are hereby authorized to execute any power of attorney required in connection with the OCS Documents; and it is

FURTHER RESOLVED: That all instruments and documents previously executed and delivered by an Authorized Officer and all actions previously undertaken by them for and on behalf of the Corporation in connection with the transactions contemplated by the OCS Documents and these resolutions, are hereby approved, ratified, confirmed and adopted in all respects; and it is

FURTHER RESOLVED: That the Authorized Officers are hereby authorized and directed to pay all costs and expenses incurred by the Corporation in connection with the transactions contemplated hereby and thereby.

*[Signature Page Follows]*

**IN WITNESS WHEREOF**, the undersigned Sole Director hereby evidences his written consent to the foregoing resolutions as of the date first above written. The undersigned direct that this Written Consent of the Sole Director in Lieu of Special Meeting be filed with the minutes of proceedings of the board of directors of the Corporation. This written consent may be executed and delivered via facsimile or by portable document format (.pdf) attachment, which shall be deemed an original.



---

Riccardo Toto



# LEGAL QUALIFICATION AND AEAU COMPANY NUMBER



*US Wind, Inc. – Nomination for Commercial Leasing for Wind Power on the Outer Continental Shelf in New York Bight in Response to BOEM's Call for Information and Nominations*



United States Department of the Interior

BUREAU OF OCEAN ENERGY  
MANAGEMENT, REGULATION AND ENFORCEMENT

Washington, DC 20240

Mr. Paolo Sammartino  
US Wind Inc.  
155 Federal Street, Suite 700  
Boston, Massachusetts 02110

APR 11 2011

Dear Mr. Sammartino:

We received your indication of interest in response to our recent Request for Interest (RFI) for Commercial Leasing for Wind Power on the Outer Continental Shelf (OCS) offshore Massachusetts on February 28, 2011. Your submittal includes documentation to demonstrate that you are legally qualified to hold a renewable energy lease or grant on the OCS as set forth in 30 CFR 285.106 and 285.107. On April 5, 2011, we received additional and corrected legal qualification documents to resolve the deficiencies in your submittal as outlined in our letter dated March 23, 2011.

We have completed our review of the legal qualification portion of your submittal and find it to be in compliance with our regulations and guidelines. Therefore, effective the date of this letter, **US Wind Inc.** is recognized as legally qualified to hold a renewable energy lease or grant on the OCS. The legal qualification documents have been placed on record in a file identified as **AEAU Company Number 15023**. This number must be included on all correspondence when referencing your legal qualifications. A copy of the official qualification card is enclosed for reference.

All legal qualification files are available for public review. Each qualified company is responsible for ensuring that its information is current. Changes and updates to qualification documents should be forwarded to: Program Manager, Office of Offshore Alternative Energy Programs, 381 Elden Street, MS 4090, Herndon, Virginia 20170, so that your qualification file can be updated. Failure to update these files may result in incorrect filings being returned.

Legal qualification documents need not be resubmitted with each lease or grant being requested. Once deemed legally qualified, documentation to establish a company's technical and financial capabilities to conduct the activities that will be authorized by each lease or grant requested need only reference the unique company number (30 CFR 285.106 and 285.107).



Please note that we may determine that a company is no longer legally qualified to hold a renewable energy lease or grant on the OCS if its operating performance is unacceptable to the Bureau of Ocean Energy Management, Regulation and Enforcement as described in 30 CFR 285.106(b).

Should you require further assistance, please contact Ms. Gina Goodwin at (703) 787-1341.

Sincerely,



Maureen A. Bornholdt  
Program Manager  
Office of Offshore Alternative Energy Programs

Enclosure

cc: Mr. Jason B. Yost, Mercer Thompson LLC

US Wind Inc.  
155 Federal Street  
Suite 700  
Boston, MA 02110

GOM COMPANY#: 15023  
Suite 700 Massachusetts Corporation  
Modified:  
Approved: 08-Apr-11

**AUTHORIZED TO CONDUCT  
THE FOLLOWING BUSINESS:**

OIL && No  
RIGHTS-OF-WAY: No  
ALTERNATIVE Yes

**AREAWIDE BONDS:**

3M DEVEL: No  
1M EXPL: No  
300K AREAWIDE: No  
PIPELINE: No  
Supplemt Exempt: No

EEO Plan: No  
Debarment: No

Qualification documents received 4/5/11, and approved on 4/8/11.

NAME	TITLE	EXPIR.
Alfonso Toto	President	

RESOLVED, that the President of the Company [US Wind Inc.] is hereby individually empowered on behalf of the Company, in any matter related to the acquisition and operation of leases, right-of-way grants, or right-of-use and easement grants for activities that produce or support production, transportation, or transmission of, energy from sources other than oil and gas on the Outer Continental Shelf (OCS), and right-of-Use and easement grants for the alternate use of OCS facilities for energy or marine-related purposes, to agree upon the terms of and to execute and deliver any instrument or agreement, including any application, bid, lease, plan, right-of-way grant, right-of-use and easement grant, bond or other financial assurance instrument, assignment, designation of operator, relinquishment, amendment, abandonment, power of attorney (including the revocation thereof), and any other paper.



# NAME, LOCATION, AND DESCRIPTION OF THE BUSINESS ENTITY



US WIND, INC. 1 North Charles Street, Baltimore, MD 21201

**NAME, LOCATION, AND DESCRIPTION OF THE BUSINESS ENTITY**

US Wind Inc. is a domestic corporation organized on February 23, 2011, under the General Laws of the Commonwealth in Massachusetts. It was set up to participate to the Offshore wind tenders in US.

The address of the office is: 1 North Charles Street, Baltimore 21201 Maryland.

After the successful BOEM auction in Maryland, US Wind opened an office in Baltimore (MD) to follow both the Maryland project as well as the participation to offshore wind projects in other US states.

US Wind is currently involved on various development activities in the offshore wind industry. Additional information on achieved milestones and current development status can be found in the document “**Company Profile**”.



# COMPANY PROFILE



US WIND, INC. 1 North Charles Street, Baltimore, MD 21201

## INTRODUCTION

The scope of this section is to provide a company profile for US Wind and the European mother companies, Renexia and Toto Group.

## MOTHER COMPANIES

### TOTO GROUP

With a history of successfully operating in the infrastructure business for over 50 years, Toto Group is a major player in the European and international market and can provide design and construction services that range from concept design to commissioning of roads, tunneling, bridges, renewable energy facilities, and deep foundation projects. With roughly 1,500 employees and a turnover of about € 450 million, the Group is rated in the top 20 Italian construction groups for infrastructure projects.

### RENEXIA

Established in 2011, Renexia and its subsidiary US Wind handle development, planning, construction, and management of renewable energy facilities. With an invested CapEx of more than € 150 million, a project pipeline of more than 1,900 MW, and core competencies in on-shore and offshore wind farms, photovoltaic, solar thermal, geothermal, and hydroelectric plants, Renexia is a leading player in the renewable energy industry.

## US WIND'S COMPANY PROFILE

US Wind Inc. is a domestic corporation organized on February 23, 2011, under the General Laws of the Commonwealth in Massachusetts. It was set up to participate to the Offshore wind tenders in US.

### WHAT WE DO

US Wind is involved in offshore wind development and construction with projects in Maryland and New Jersey and with development interests in South Carolina.

**Maryland Project** – A commercial lease sale for Maryland was held on Aug. 19, 2014. At the end of the sale, BOEM announced that US Wind Inc. was the provisional winner of both leases, North Area (32,737 acres) and South Area (46,970 acres), for a total bid of \$8,701,098. In total, the WEA covers approximately 80,000 acres. Today, the Maryland Project is close to the end of the development phase. The Maryland Project is in an advanced development phase.

**New Jersey Project** – On Nov. 9, 2015, BOEM held a competitive lease sale for the WEA offshore New Jersey. US Wind Inc., which bid \$1,006,240, was the winner of one of the two leases, the OCS-A 0499 (North Area). The North lease covers an area of approximately 183,000 acres.

**South Carolina** – On November 23, 2015, BOEM published a Call for Information and Nominations in the Federal Register (under Docket ID: BOEM-2015-0134) for a 60-day public comment period to gauge the offshore wind industry's interest in acquiring commercial wind leases in four areas offshore South Carolina and to request comments regarding site conditions, resources and other uses within the Call areas. The comment period ended on Jan. 25, 2016. Scope of the invitation was the submission of nominations for commercial wind leases that would allow a lessee to propose the construction of a wind energy project on the Outer Continental Shelf (OCS) offshore South Carolina, and to develop the project if approved.

In response to the above Call for Information, BOEM received some nominations. In particular, for one of the four areas, the Grand Strand Call, two companies participated:

- US Wind (nomination for a portion of the full area);
- Fishermen’s Energy (nomination for the full area);

BOEM has initiated a review of these parties’ submissions to assess filing completeness; evaluate legal, technical, and financial qualifications to hold an OCS (Outer Continental Shelf) renewable energy commercial lease; and determine competitive interest within the areas nominated.

## OUR VISION

Our vision is to use proven technology to create good jobs and provide clean domestic energy for a sustainable future.

**Proven Technology** – Humans have been harnessing the power of the wind for more than 2,000 years. Sailors use the wind to navigate the seas, farmers use wind-powered mills to grind grain and ranchers use wind to power water-pumps for livestock. Now, modern technology allows us to generate clean, renewable energy from offshore wind. Offshore wind turbines are already being successfully used in Europe and other parts of the world. Offshore winds are generally more consistent and stronger than winds over land. Harnessing the power of offshore winds will help our country meet its renewable energy goals, build a modern, clean energy economy and ensure healthy, sustainable communities.

**Good Jobs** – Offshore wind will create and support local, highly-skilled jobs. Industry supported jobs include engineering, construction, surveyors, scientists and tradespeople. Offshore wind projects can help revitalize area manufacturing sectors and ports and form the basis for a stable workforce for decades. The offshore wind industry already employs tens of thousands of workers in Europe – it’s time for America to compete in this 21st century industry. Wind energy projects typically require hundreds of different products and components. Skilled labor is required to build, assemble and maintain wind turbines and the infrastructure that supports them. U.S. businesses that are involved with offshore wind will be well-positioned to bring jobs and manufacturing to the states along the east Atlantic coast. Once a domestic wind energy industry is established, there may even be opportunities for America to export services around the world.

**Clean Domestic Energy** – Governments around the globe are working to reduce carbon emissions and transition away from fossil fuels like coal and oil. Offshore wind is an excellent source of clean, reliable renewable energy, and the wind blowing off the Atlantic coast is a vast, untapped energy source. Increasingly, Americans are demanding cleaner and more sustainable choices for their electricity. Wind energy has zero emissions, and no threat of toxic spills or damaging explosions.

**Sustainable Future** – Americans want healthy, safe and vibrant communities – and offshore wind can help achieve this sustainable future. Displacing fossil fuel burning power plants with clean offshore wind turbines will help improve the air we breathe and supply modern job opportunities for today’s 21st century economy. Offshore wind sites must undergo strict environmental reviews to protect wildlife and habitat. US Wind is committed to exceptional stewardship of our oceans and offshore ecosystems. Offshore wind is truly a responsible, renewable and sustainable source of energy to meet our country’s needs.

## ADDITIONAL INFORMATION

The attached documents provide additional information on the company profile.



 **TOTO** Holding | Company profile

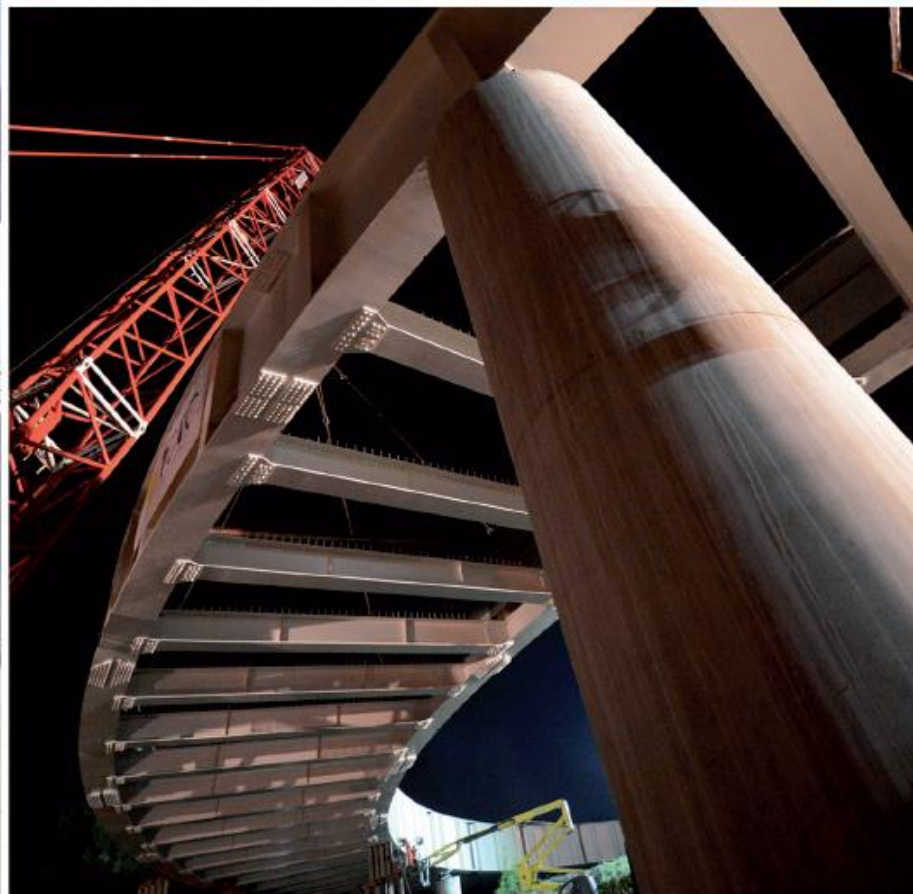



# Toto S.p.A. Costruzioni Generali | contact

---

## HEAD QUARTER

Viale Abruzzo, 410  
66100 Chieti (CH) – Italia  
Phone +39 0871 58741  
Fax. +39 0871 552624  
info@totospa.it

## Warsaw Offices

Prosta Tower  
ul. Prosta 32  
00-838 Warszawa (Poland)  
Phone +48 (61) 222 54 90  
Fax. +48 (61) 222 54 95  
biuroS5@totospa.it

## Middle East Branch

Units No. 13703-030  
Cluster V Business Centre 2  
Jumeirah Lakes Towers  
P.O. Box-391613, Dubai  
Unit Arab Emirates  
Tel. +971 43735700 Fax +971 44390185  
mena.development@totospa.it

## Rome Offices

Via Sardegna, 14  
00187 Roma Italy  
Phone +39 06 4883642  
Fax +39 06 4883645  
inforoma@totospa.it

## U.S.A. Offices

1 North Charles Street, Suite 2310  
Baltimore, MD 21201  
Phone +1 410 727 4020  
info@uswindinc.com

## Czech Republic Offices

U průhonu 1516/32  
170 00, Praha - Holešovice





# Table of Content

---

- History
- Structure
- Financial Data
- Area of Operations & Projects Location
- Strada dei Parchi
- Parchi Global Services
- InfraEngineering
- Renexia
- Toto Costruzioni Generali
- Updated Figures
- TCG Organization
- Core Competencies
  - Tunnelling
  - Viaducts
  - Renewable Energy
  - Prefabrication
  - Deep Foundations
- Technological Assets
- Certifications & Awards





# History

---

- 1961 Toto Family starts its activities.
- 
- 1970s The Company develops unique competencies in self-execution  
1980s of motorways, railways, tunnels and bridges.
- 
- 1986 The Group is the largest Italian manufacturer of heavy-precast elements, with overall 12 production sites.
- 
- 1988 The Group enters the airline business, previously under State monopoly, rapidly becoming the second Italian air carrier, under the brand of AirOne.
- 
- 1997 The first overseas contract is awarded in Lebanon to build a section of the Arab Highway which comprises of the highest viaduct in the Middle East.
- 
- 2001 The Group enters the concession business through the 300 km «Strada dei Parchi» highway, linking the East and the West coasts of Italy.
- 
- 2006 The first private rail cargo operator in Italy is founded under the name of Rail One.

# History

---

- 2008 APFL is established in Ireland and with its 60 aircrafts fleet is one of the largest in Europe.
- 
- 2010 Med Wind is founded in Tunisia to develop the first wind farm (90 MW) in the Country.
- 
- 2011 “Martina”, the world’s largest explosion-proof TBM, jointly designed and manufactured by Toto and Herrenknecht, is ready to bore the Sparvo Tunnel on A1 Highway.
- 
- 2013 Toto is awarded the prestigious prize “Contractor of the Year” at NCE International Tunnelling Awards for the Sparvo Tunnel project.
- 
- 2014 Toto enters the North American energy market through its subsidiary US Wind, signing a BOT to operate the largest US offshore wind farm in Maryland.
- 
- 2015 Expansion on international markets continues in Poland with the acquisition of a 16 km stretch of the S5 Expressway, running in a Natura 2000 protected environment. US Wind is awarded the second offshore wind farm in New Jersey.
- 
- 2016 Ranked first on Rv 77 Tjernfjellet Tunnel in Norway.  
Ranked first on the D1 Prague – Brno Highway Project in Czech Republic.

# Group Structure

 **1.500**

Over 1,500 directly employed

**€ 450**

450 M € average turnover

 **20**

Rated among the top 20 Italian industrial groups

 **50**

Successfully operating in the infrastructure business for over 50 years

 **TOTO Holding**

**TOTO**  
COSTRUZIONI GENERALI

 **strada dei  
PARCHI** spa  
A24 autostrade A25

 **Infra  
Engineering**

 **Renexia**

 **Parchi  
Global Services**

 **TOTO Real Estate**

## Structure | Toto Group today

TCG is a major player in the European and International market with high technical and financial capacities. Through the parent company *Toto Holding* and its wholly-owned subsidiaries *Infraengineering* and *Strada dei Parchi*, TCG can provide design & build services that range from concept design to commissioning of roads, tunnelling, bridges, renewable energy plants and deep foundations projects.

With roughly 1500 employees and a turnover of about € 450 million, the Group is rated in the top 20 Italian construction groups for infrastructure projects.

Roads and motorways, railways and renewable energy plants, civil and industrial buildings are the key sectors where the Group has been operating in for the last 50 years, always with the same passion for building, numerous consolidated and successful achievements.

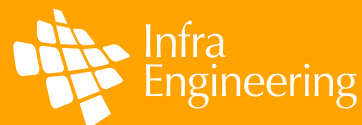

# Financial Data M€

## Revenues

Ebitda Ebit

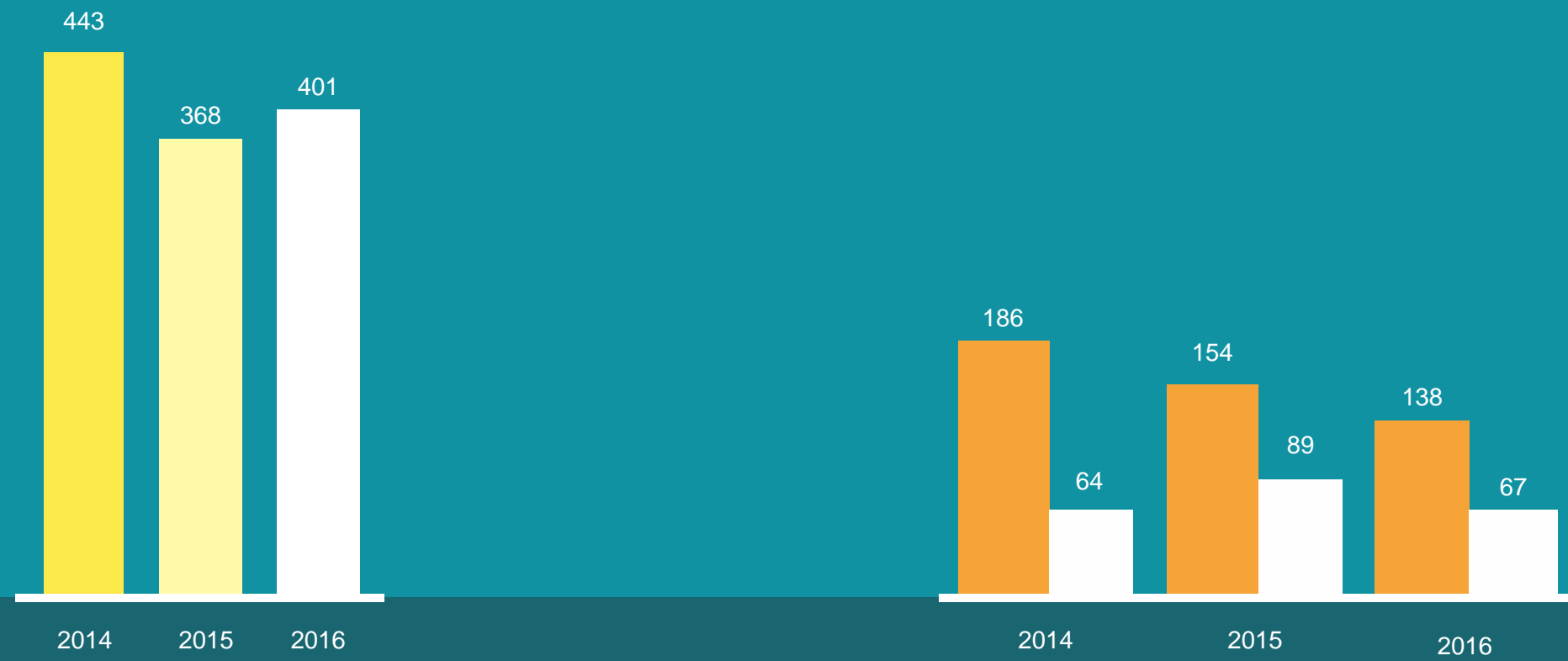

# Area of Operations

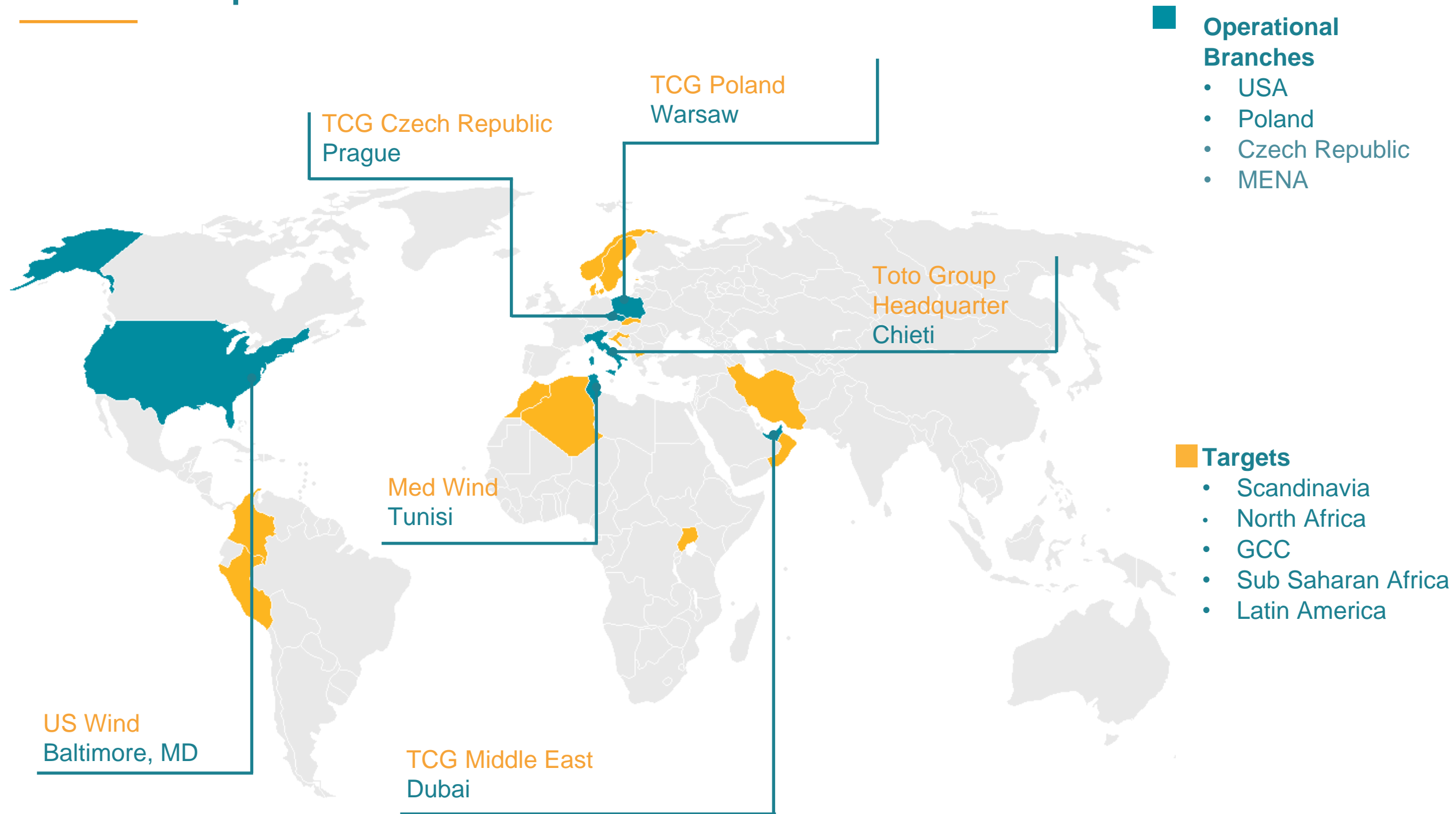



# Project locations

## Poland S5 Expressway

Type: Motorway  
Client: GDDKiA  
Value: 127 mln €

## Czech Republic D1 section 12

Type: Motorway  
Client: ŘSD ČR  
Value: 78 mln €

## Martingnano Tunnel

Type: Tunnelling  
Client: Provincia autonoma di Trento  
Value: 111 mln €

## La Spezia

Type: Motorway  
Client: Anas  
Value: 125 mln €

## A1 Valico Bypass

Type: Motorway – Tunnelling - Viaduct  
Client: Autostrade per l'Italia  
Value: 1.040 mln €

## A24 Sideroads

Type: Motorway  
Client: Strada dei Parchi  
Value: 203 mln €

## Monte Eboli Power Plant

Type: Photovoltaic Plant  
Client: Monteboli S.p.A.  
Value: 73 mln €

## S.S. Picente L4

Type: Motorway  
Client: ANAS  
Value: 42 mln €

## A3 Salerno – Reggio Calabria

Type: Motorway – Tunnelling - Viaduct  
Client: ANAS  
Value: 430 mln €

## Cefalù Railway

Type: Railway - Tunnelling  
Client: Italferr  
Value: 258 mln €

## Messina Motoway Junction

Type: Motorway  
Client: CAS  
Value: 44mln €

## El Houaria Windfarm

Type: Eolic Plant  
Client: STEG  
Value: 150 mln €

## Hadath-Syrian Border Highway

Type: Viaduct  
Client: Lebanese Republic (Beirut)  
Value: 52 mln €



# Strada dei parchi

Established in 2001, SdP is the Group's Concessionaire for A24-A25 motorway



## Network

**281** km motorway  
**570** km lanes



## Infrastructures

**153** viaducts  
**54** tunnels



## Services

**28** toll-gates  
**12** vv  
**113** info panels



## Safety

**33%** draining asphalt  
**18** ice sensors  
**430** SOS posts

Over 70km of tunnels including the longest twin tunnel in Europe

## Annual Traffic Volume (M/km)

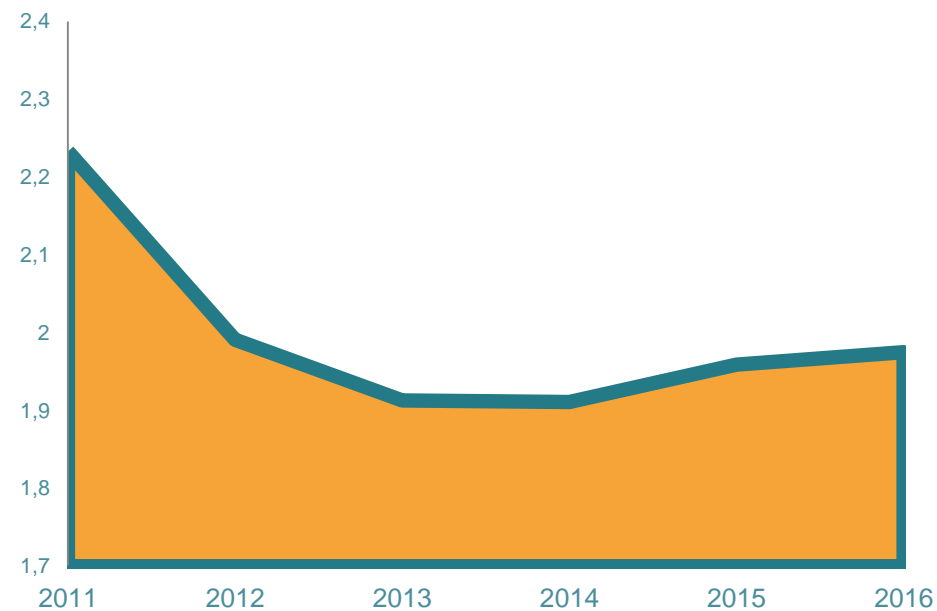

# Parchi Global Services

---

A Group's subsidiary in charge of the maintenance of "Strada dei Parchi" highway.



## Mission

Develop and manage an efficient motorway network guaranteeing high quality, safety and service standards.



## Core Competencies

Maintenance of 300 km mountainous highway and winter operations.





# InfraEngineering

---

Established in 2011, InfraEngineering is in charge of planning, supervision and design of more than 560km highways.

Main activities include feasibility studies, planning and design of large infrastructure projects.

🕒 **Planning**    🕒 **Design**    🕒 **Supervision**

---

## Completed Projects

### Road infrastructures

Reno Viaduct

.....

Aglio Viaduct  
improvement of the  
seismic resistance of 150  
bridges on A24-A25

.....

Upgrading  
of tunnels on A24-A25

.....

A24 Highway Urban Section  
to Rome city centre

### Industrial Plants

Precast elements fabrication

---

### Renewable Energy

Monteboli Photovoltaic Park

.....

Ponte Albanito Wind Farm

.....

Circello Wind Farm

### Civil and Industrial

Toto Group headquarter

.....

Pescara Airport AirOne  
Hangar



# Renexia

---

Established in 2011, Renexia and its subsidiary US Wind handle the development, planning, construction and management of Renewable Power Plants.

## Core Competencies

- On-shore Wind Farms  
.....
- Off-shore Wind Farms  
.....
- Photovoltaic plants  
.....
- Solar thermal systems  
.....
- Geothermal systems  
.....
- Hydroelectric plants

## Technologies

- 2 Photovoltaic Plants
- 4 On-Shore Wind Farms
- 2 Off-Shore Wind Farms

---

### CAPEX invested

> 150 mln EUR

---

### Pipeline

> 1,900 MW





# Toto Costruzioni Generali S.p.A.

---

EPC Contractor with more than 50 year experience in the construction sector with in house design capabilities and unique competencies in the execution of large infrastructure projects.

A problem-solving approach and a strong, strategic planning and programming cycle ensuring the effective and timely delivery of our projects.

## Business Areas

- Roads and motorways
- Railways
- Civil and industrial Buildings
- Renewable power plants

## Core Competencies

- Tunnelling (TBM and traditional)
- Viaducts (precast and cast in situ)
- Deep foundations
- Prefabrication of girders and tunnel segments



# Updated Figures

More Than:



**135 km tunnels**  
(63km greenfield)



**450.000 m**  
of Bored Piles



**€ 110 M**

directly invested in equipment



**100 km of Viaducts**  
(41km greenfield)



**3,000 km**  
of Precast Beams  
Manufactured in 20 years



# Core Competencies | Tunnelling

TBM, Drill and Blast, Excavation Sustained Method

Tunnel	L	TBM	E. S.	D&B
Val di Sambro (A1 Valico Bypass)	4km		<input checked="" type="checkbox"/>	
Allocco (A1 Valico Bypass)	3,5 km		<input checked="" type="checkbox"/>	
Vado (A1 Valico Bypass)	2,2 km		<input checked="" type="checkbox"/>	
Carestia (A24 Motorway)	0,8 km		<input checked="" type="checkbox"/>	
Sparvo (A1 Valico Bypass)	5 km*	<input checked="" type="checkbox"/>		
Cefalù (Palermo Messina Railway)	22 km	<input checked="" type="checkbox"/>		
Martignano (S.S. 47 Valsugana)	5,4 km	<input checked="" type="checkbox"/>		
Valbiano (E45 Orte-Ravenna)	5 km			<input checked="" type="checkbox"/>

\*over 1 km below an underground lake





# Core Competencies | Viaducts

Cranes, Incremental Launch, Balanced Cantilever, Twin Truss Launcher

## Balance Cantiliver

Construction of cast-in-situ or precast segments, starting from the pier segments and then advancing towards the center of the span using front travelers. Toto used Balanced Cantilever technology to build the Aglio viaduct on the Valico Bypass and the Fuomi viaduct on the Salerno-Reggio Calabria Highway.

## Pre-stressed Concrete

Precast girders in pre-stressed concrete, launched by powerful launching girders and gantries, with cast in situ reinforced concrete top slab. Toto used this method to build the Mdeirej viaduct in Lebanon, the San Antonio viaduct on the A24 Highway and a bridge on the river Pescara.

## Composite Structure

Steel beams launched by powerful cranes and gantries, with cast in situ reinforced concrete slab. Toto built the Stura di Demonte viaduct and several viaducts on the Valico Bypass and along the A24 Side-roads near Rome using this method.

## Incremental Launch

The first section of the launch is a stiffened steel plate girder. Each pre-stressed concrete section of the bridge is prefabricated at one end of the bridge and positioned one after the other over sliding bearings. Toto used incremental launching method to build the Reno viaduct on the Valico Bypass.



# Core Competencies | Renewable Energy

---



## Solar

TCG installed more than 100 thousand panels in Monteboli, for a plant operating under a Power Purchase Agreement. This 24 MW photovoltaic park is one of the largest in Italy.



## Wind

Over the years, TCG has been involved in several projects in Italy as well as in North Africa. Through its Boston-based US Wind, Toto is currently building the largest offshore wind farm in the United States, 15 miles off the coast of Maryland with total installed power of 750 MW.





## The Renewable Energy Business

---

Renexia, established in 2011, carefully analyzes and selects investment opportunities in countries where wind and photovoltaic farms generate a stable and predictable cash flow, supporting the Group's growth. The strategy is to pursue portfolio diversification both in terms of technology and in terms of geographical areas.

Project	Location	Technology	MW	Status	Year
Intersun	Abruzzo Italy	Photovoltaic	3,5	In Operation	2012
Monteboli PV	Campania Italy	Photovoltaic	24	In Operation	2012
Ponte Albanito	Puglia Italy	Wind On-Shore	22,8	In Operation	2014
Casalduni	Campania Italy	Wind On-Shore	36	Under Construction	2016
Circello	Campania Italy	Wind On-Shore	27	In Operation	2017
US Wind MD	U.S.A.	Wind Off-Shore	750	In Process	2017
US Wind NJ	U.S.A.	Wind Off-Shore	3000	In Process	2018
Tunisia	Tunisia	Wind On-Shore	90	In Process	2016
<b>TOTAL</b>			<b>3953,3</b>		



# Core Competencies | Prefabrication

---

Prefabrication is a crucial activity for Toto, which took the strategic decision to make it part of its core competencies in order to: handle all of the project, guarantee product quality and develop techniques that reduce time and cost of both construction and site logistics.

## Lebanon

A precast plant to produce 40 metres long prestressed beams weighing 168 tonnes each.

## Martignano

24.000 tunnel lining segments produced.

## Sparvo

For Lots 6/7 of the A1 Valico Bypass, Toto installed one of the largest segment manufacturing plants in the world with a record-breaking daily output of 540 cum of precast elements.

## Lunghezza

Traffic constraints lead to the decision to set a dedicated plant to manufacture precast elements on the urban stretch of the A24 Highway.





# Core Competencies | Deep foundations

Project	Work type
S.S. 487 Caramanico-Pescara	shafts, tunnel consolidation
Villa Zaccheo	piles
A24 Val Vomano	micropiles
A1 Valico Bypass - Mugello	tunnel consolidation
A1 Valico Bypass – Val di Setta	large diameter piles
S.S.1 Aurelia - La Spezia	piles, micropiles, tunnel consolidation, diaphragm wall, grouting
S5 Expressway - Poland	piles



# Technological Assets

Item description	N. of items	Item description	N. of items
Transit Mixer	20	Motrograders	2
Trucks	37	Batching Plants	2
Cranes	15	Cement mortar injectors	25
Truck with cranes	6	Motocompressors	27
Formworks sets	44	Conveyors	5
Launching girders	9	Drilling Machinery	21
TBM Ancillary Equipment	44	Asphlat Pavers	1
Demolition Hammer	27	Pumps	22
Dumper	5	Lifts	38
Excavators	26	Trailers	22
Loaders	23	Compactors	5
Bulldozers	4	TBM	4

# Technological Assets

---

## TBM's

### EPBM S-574 "Martina"

- Boring diameter: 15,62 m
- Cross section: 192 m<sup>2</sup>
- Total weight: 4500 t
- Total installed power: 18 MW

.....

### Hard Rock Single Shield TBM S-251 "Tecla"

- Boring diameter: 12,11 m
- Cross section: 115 m<sup>2</sup>
- Total weight: 3700 t
- Total installed power: 5 MW

.....

### TBM 3/4 - Cefalù

- Boring diameter: 9,96 m
- Cross section: 78 m<sup>2</sup>
- Total weight: 1500 t
- Total installed power: 5,6 MW

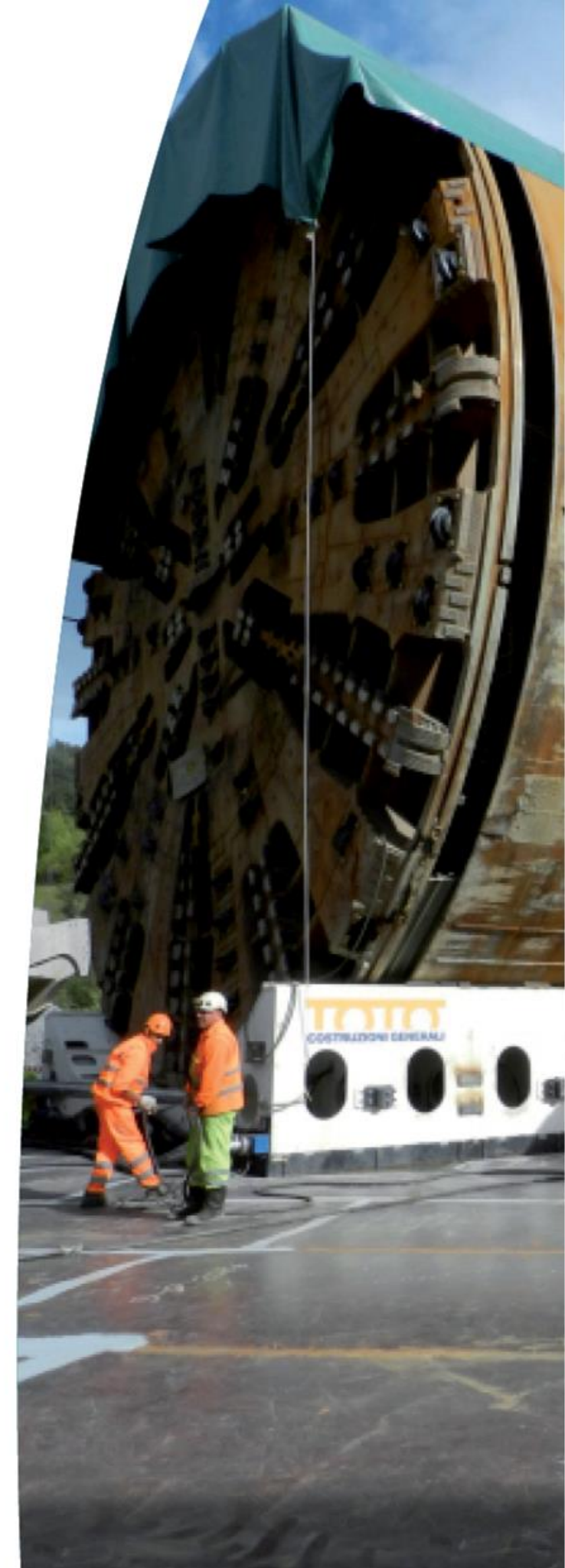

# Certifications

---

The Group has internally developed a strong culture based on international standard with regard to Health & Safety Environment, policy and requirements.

The priority for each employee is to act with the highest integrity for respecting Health & Safety measures.



Toto S.p.A. is certified and qualified for design and construction of projects for unlimited amount.





# Certifications

## Certificate

Standard **ISO 14001:2004**

Certificate Registr. No. 01 104 087401

TÜV Rheinland Cert GmbH certifies:

Certificate Holder: **Toto S.p.a. Costruzioni Generali**  
V.le Abruzzo, 410  
I - 66013 Chieti (CH)

Scope: Design and construction of infrastructure and civil engineering works such as private and industrial buildings, roads, highways, bridges, viaducts, tunnels, power plants and related complementary and specialized works such as special structural works, road barriers and road protections

An audit was performed, Report No. 087401. Proof has been furnished that the requirements according to ISO 14001:2004 are fulfilled.  
The due date for all future audits is 29-10 (dd.mm).

Validity: The certificate is valid from 2014-01-16 until 2016-12-21.  
First certification 2010

2014-01-16

  
TÜV Rheinland Cert GmbH  
Am Grauen Stein · 51105 Köln



## Certificate

Standard **BS OHSAS 18001:2007**

Certificate Registr. No. 01 113 060458

TÜV Rheinland Cert GmbH certifies:

Certificate Holder: **Toto S.p.a. Costruzioni Generali**  
V.le Abruzzo, 410  
I - 66013 Chieti (CH)

Scope: Design and construction of infrastructure and civil engineering works such as civil and industrial buildings, roads, highways, bridges, viaducts, tunnels, power plants and related complementary and specialized works such as special structural works, road barriers and road protections

An audit was performed, Report No. 060458. Proof has been furnished that the requirements according to BS OHSAS 18001:2007 are fulfilled.  
The due date for all future audits is 29-10 (dd.mm).

Validity: The certificate is valid from 2014-01-16 until 2016-12-21.  
First certification 2011

2014-01-16

  
TÜV Rheinland Cert GmbH  
Am Grauen Stein · 51105 Köln



## CERTIFICATE

The Certification Body TÜV Rheinland Italia S.r.l.

certifies, in accordance with the TÜV Rheinland Group procedures, that the Company

**TOTO S.p.A. Costruzioni Generali**

**V.le Abruzzo, 410**

**I - 66013 Chieti (CH)**



has established and applies a quality management system for the following scope:

**Design and construction of infrastructure and civil engineering works such as civil and industrial buildings, roads, highways, bridges, viaducts, tunnels, power plants and relative complementary and specialized works such as special structural works, road barriers and protections. (EA28)**

**Management of General Contracting activities carried out pursuant to article 176 of Legislative Decree no. 163 of 12 April 2006, and subsequent modification and supplements. (EA35)**

Through an Audit, Report No. 0010504, proof has been furnished that the quality management system fulfils the requirements of the standard

**UNI EN ISO 9001:2008**

evaluated according to the requirements of the Document ACCREDIA RT-05.

Please refer to the Quality Manual for the details about the exclusions with respect to the requirements of the standard.

Certificate Registration No. **39 00 0010504**.

This Certificate is valid from 2014-11-25 to 2017-11-24.

The reference date for all the next audits is (day-month): 20-11.

Milan, 2014-11-26. First Certification: 2002-12-08

*Elio Soletta*

The certification responsible  
TÜV Rheinland Italia S.r.l., Via E. Mattei, 3 - I - 20010 Pogliano Milanese (MI)



5122 N° 853A  
Membro degli Accordi di  
Mutuo Riconoscimento EA, IAF e ILAC  
Signatory of EA, IAF and ILAC  
Mutual Recognition Agreements



www.tuvitalia.com

This certification is related to the management aspects of the Organization as a whole and it can be used for the purpose of the qualification of the construction Organizations according to the article 40 of the Law 12 April 2006 n° 163 with the following changes and to the D. P. R. 5 October 2010, n° 207.

For any punctual and updated information about the possible changes in the status of the certification related to this certificate, please contact the telephone No. +39 02 330.687.1 or the e-mail address [informazioni@it.tuv.com](mailto:informazioni@it.tuv.com)



# Awards

---



“The use of innovative solutions, attention to detail around planning and risk management, and the engagement of staff and stakeholders makes this an exemplar of how to deliver a complex tunnelling project”

International Tunnelling Awards jury on Sparvo project,  
London 26th November 2013



[WWW.TOTOHOLDING.IT](http://WWW.TOTOHOLDING.IT)



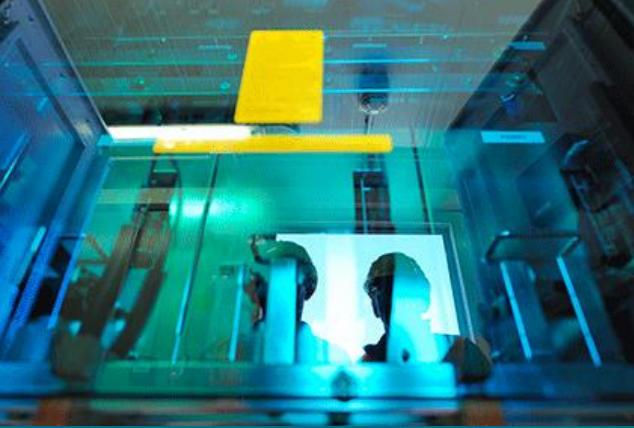

# TOTO Group Renewable Energy Projects

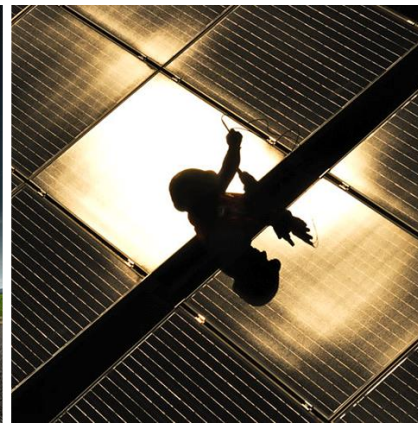



# CORPORATE STRUCTURE

# Group Structure

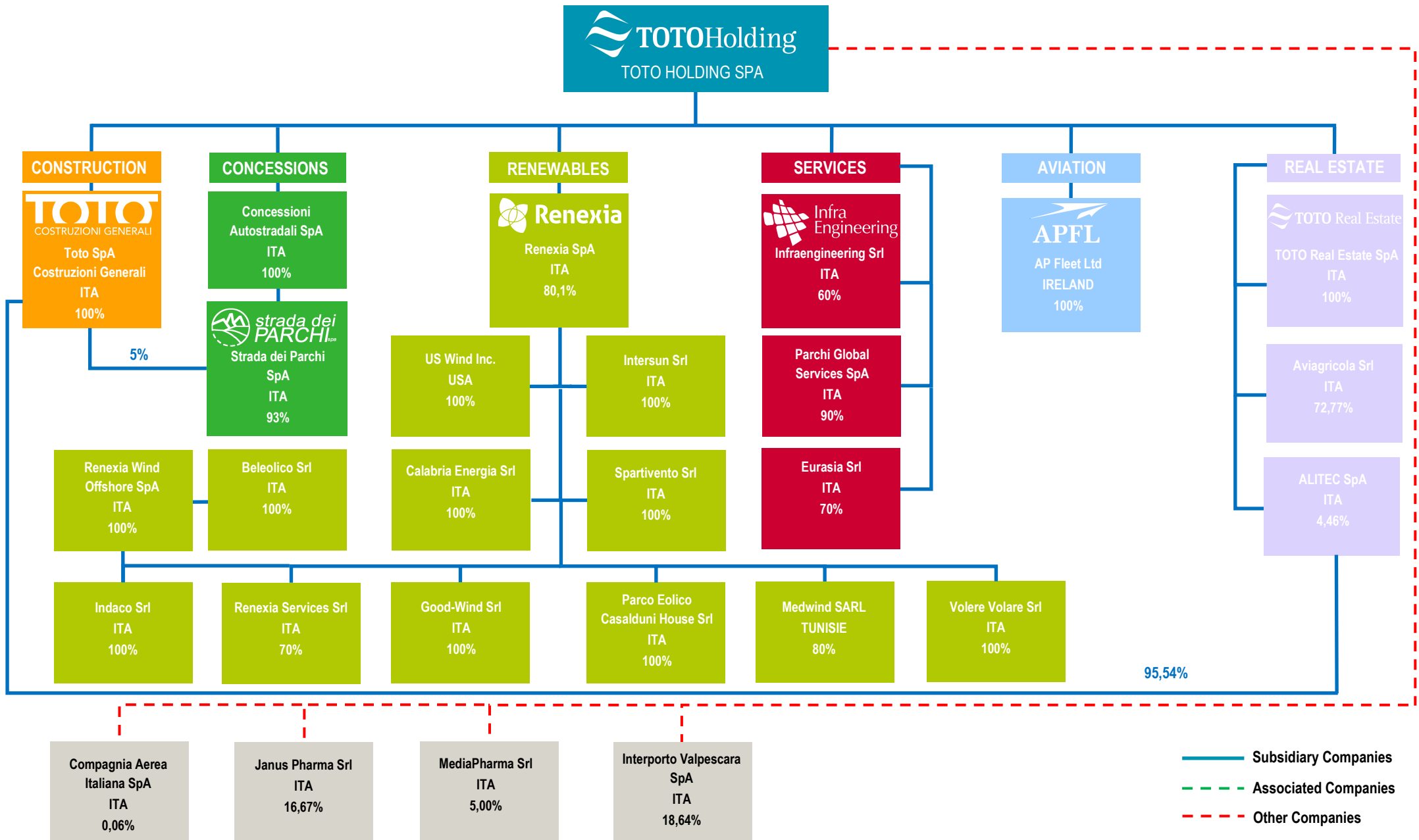





# YEARS IN OPERATION

*US Wind, Inc. – Nomination for Commercial Leasing for Wind Power on the Outer Continental Shelf in New York Bight in Response to  
BOEM's Call for Information and Nominations*

As described on page 4 of the Company Profile, the Toto group is active since the sixties. US Wind Inc. is in operations since February 2011.



Chieti (Italy), July 25<sup>th</sup>, 2018

---

Mr. Riccardo Toto

Sole Director

# BANKRUPTCY STATEMENT

*US Wind, Inc. – Nomination for Commercial Leasing for Wind Power on the Outer Continental Shelf in New York Bight in Response to BOEM's Call for Information and Nominations*

During the last 5 years neither US Wind Inc. nor any company belonging to the Toto Group incurred in any bankruptcy situation or similar event.

Chieti (Italy), July 25<sup>th</sup>, 2018

Mr. Riccardo Toto

Sole Director



# KEY PERSONNEL

**INTRODUCTION**

US Wind is a leading offshore wind company in the United States of America. Since its incorporation in 2011, US Wind achieved some important milestones, developing a unique experience in the U.S. market. Specifically:

- US Wind is the only company, together with Skipjack, to have received an OREC award from the State of Maryland;
- Successfully submitted and received approval from BOEM on a Site Assessment Plan (SAP);
- Successfully completed the conceptual and preliminary engineering for the wind farm, evaluating the best available technologies in the European market and adopting them for the US market;
- Successfully completed the interconnection process with PJM;
- Developed strong knowledge and relationships with US offshore wind supply chain.

The above milestones position US Wind as one of the very few companies to have experience in the U.S. offshore wind industry. All the personnel listed below have been involved in previous US Wind projects.

In addition to the above, US Wind can rely on the extensive experience in renewable energy brought by Renexia. The key personnel in Renexia successfully completed or are completing projects in various parts of the world. Indeed, Renexia is going to build the first offshore wind farm in the Mediterranean: the Taranto Offshore Wind Farm Project; the wind farm is fully engineered, fully permitted, and is going in construction phase next year. Renexia is actually finalizing the remaining EPC contracts. Below there is a list of US Wind’s key personnel.

Name & Credentials	Work Experience
<p><b>Riccardo Toto</b> President</p>	<p>Over 15 years of top management expertise in heavy capitalized companies active in different areas of business, including renewable energies, aviation, and railways. Since 2015, President and Sole Director at US Wind.</p>
<p><b>Paolo Sammartino</b> Executive Vice President</p>	<p>Extensive experience in project management in the renewable energy industry, including 27 MW wind farm in Circello (Italy), 22 MW wind farm in Foggia (Italy), 50 MW concentrated solar panel (CSP) in Southern Italy, 24 MW photovoltaic (PV) solar facility in Salerno (Italy). Led the US Wind’s team in the Federal Lease Auction processes for both Maryland and New Jersey and leads the team in the offshore wind development in the United States. Since 2015, Executive Vice President at US Wind and Chief Operating Officer at Renexia.</p>
<p><b>Salvo Vitale</b> General Counsel</p>	<p>Experienced Legal Counsel with a demonstrated history of success in the renewables and environment industry. Goal oriented manager with a strong legal background. Highly skilled in management, negotiation, legal writing, extraordinary transactions and corporate governance.</p>
<p><b>Francesco Onorio</b> Lead Program Manager</p>	<p>Extensive experience in a variety of management positions on billion dollar-size projects in Europe, Egypt, Saudi Arabia, Australia, Kazakhstan, and United States. Francesco oversees the overall project delivery managing Engineering, Permitting, Schedule, DevEx, CapEx, OpEx, and Procurement.</p>

<p><b>Armando Tarquini</b> Finance Manager</p>	<p>Extensive experience in finance management (accountancy, financial statements, management control, internal/external audit, tax), project finance, and project evaluation in the renewable energy industry.</p>
<p><b>Paul Rich</b> Development Director</p>	<p>Extensive experience in renewable energy with a previous experience in offshore wind as a Development Officer at Deepwater Wind. Paul oversees Public Relations, Public Outreaches, Stakeholder Relations, and Government Relations.</p>
<p><b>Jennifer Banks</b> Permitting Specialist</p>	<p>Extensive experience in the environmental and permitting fields. Jen is responsible for the various permitting efforts and coordination with the Bureau of Ocean Energy Management (BOEM), state agencies, environmental organizations, and NGOs.</p>
<p><b>Elena Starchenko</b> Technical Specialist &amp; MBE Liaison</p>	<p>Extensive experience in electrical engineering and technical coordination. Elena is responsible the various engineering packages of the project (electrical, civil, energy, etc.). Elena also oversees relations and public outreaches with Minority Business Enterprise companies being key contact with the Governor’s Office of Small, Minority &amp; Woman’s Business Affairs (GOSBA) and other similar relevant stakeholders.</p>
<p><b>Christiana Ferguson</b> Office Manager &amp; MBE Liaison</p>	<p>Christiana took the role of Office Manager in 2017 and MBE liaison in 2018, overseeing relations and public outreaches with Minority Business Enterprise companies being key contact with the Governor’s Office of Small, Minority &amp; Woman’s Business Affairs (GOSBA) and other similar relevant stakeholders.</p>
<p><b>Moreno Ferracci</b> Operations Manager</p>	<p>Over 30 years of experience in offshore engineering and installations around the world on a variety of projects in the Oil &amp; Gas industry. Moreno oversees the offshore operations for US Wind.</p>
<p><b>Monia Di Loreto</b> Accounting Manager</p>	<p>Monia Di Loreto oversees the Account Payable department and is the company’s key person for cash flow planning, project controlling, and cost compliance.</p>
<p><b>Gianni Di Virgilio</b> Project Eng. / Cables &amp; Electrical Eng.</p>	<p>Extensive experience in on-shore cables, offshore cables, and electrical engineering. Gianni oversees the layouts definition and the correct placement of turbines, substations, and cables.</p>
<p><b>Piero Melideo</b> Project Eng. / SCADA &amp; Energy Assessments</p>	<p>Extensive experience in Supervisory Control and Data Acquisition (SCADA) systems and energy assessments. Piero is a wind analyst and oversees the energy production estimates for both on-shore and offshore wind farms.</p>